

## HOOD

**WARNING: IF EQUIPPED WITH AIR CUSHION RESTRAINT SYSTEM, DO NOT ATTEMPT ANY ADJUSTMENT, REPAIR OR REMOVAL OF ANY PORTION OF THE CHASSIS SHEET METAL WHICH WOULD REQUIRE REMOVAL OR DISCONNECTING OF THE BUMPER IMPULSE DETECTOR UNTIL THE DISCONNECTION PROCEDURE IS COMPLETED. THIS PROCEDURE MUST BE FOLLOWED TO PREVENT ACCIDENTAL DEPLOYMENT OF THE SYSTEM WHICH COULD RESULT IN PERSONAL INJURY AND/OR DAMAGE TO THE SYSTEM'S COMPONENTS. IN ADDITION, CARE MUST BE EXERCISED TO NEVER BUMP OR STRIKE THE BUMPER IMPULSE DETECTOR IN A MANNER WHICH COULD CAUSE INADVERTENT DEPLOYMENT OR IMPROPER OPERATION OF THE SYSTEM.**

### A.C.R.S. DISCONNECTION PROCEDURE

1. Turn ignition switch to "LOCK" position. Disconnect the negative battery cable from the battery and tape end.

## CONTENTS

<b>DESCRIPTION AND OPERATION:</b>	
Description of Hood .....	8A-1
<b>DIAGNOSIS:</b>	
Hood Noise or Panel Flutter .....	8A-1
<b>MAINTENANCE AND ADJUSTMENTS:</b>	
Hood Adjustment .....	8A-2
<b>MAJOR REPAIR:</b>	
Hood Removal and Installation .....	8A-2
Hood Hinge Spring Removal and Installation .....	8A-2
Hood Hinge Removal and Installation .....	8A-2
<b>SPECIFICATIONS: (Not Applicable)</b>	

## DESCRIPTION AND OPERATION

### DESCRIPTION OF HOOD

#### All Series

The hood panel is of one piece construction reinforced by stamped sheet metal.

The front of the hood is held down by a ratchet-type latch which is released from the grille opening on H Series, from the front bumper opening on X Series, and from the passenger compartment on A-B-C-E Series. After the latch is released, a secondary latch must be released at the front of the hood.

**CAUTION:** *This hood lock catch assembly to radiator grille center support fastener is an important attaching part in that it could affect the performance of vital components and systems, and/or could result in major repair expense. It must be replaced with one of the same part number or with an equivalent part, if replacement becomes necessary. Do not use a replacement part of lesser quality or substitute design. Torque values must be used as specified during reassembly to assure proper retention of this part.*

## DIAGNOSIS

### HOOD NOISE OR PANEL FLUTTER

#### All Series

Squeaks or grunting noises in the hood when driving over rough roads do not necessarily indicate misalignment of hood or fenders. These noises may be caused by metal contact at some point where clearance should exist or by worn or dry hood bumpers.

If the hood squeaks, check for uniform clearance all around the hood and fenders. If an edge of metal is making contact at any point where clearance should exist, a bright metal spot will usually be found. Such spots may be depressed by spring hammering to provide clearance.

A grunting noise in the hood is usually caused by dry rubber bumpers on fender rails and cowl ledge lacing. Lubricate all rubber bumpers on fender rails and cowl with silicone rubber lubricant. To correct a persistent case of squeaking or grunting where hood to panel contacts ledge lacing, even when lubricated, cement a 1/16 inch thick strip of felt to panel where the lacing makes contact.

To prevent hood panel flutter, the rear end of the hood panel must have firm contact with the rubber bumpers and lacing attached to cowl ledge.

## MAINTENANCE AND ADJUSTMENTS

### HOOD ADJUSTMENT

#### Hood Alignment Inspection

When the hood is closed and latched, it should bear firmly against the front rubber bumpers on upper tie bar. Height of hood and width of space between hood and fenders should be reasonably even from front to rear.

#### All Series Adjustment

1. Hood Set: First, the hood opening must have parallel gaps to front end panel (or grille) and fenders. Lower the hood gently to down position and determine the correct move to make fore and aft at the hood hinge to hood attachment. This is done by simply assuming the hinges aren't even there; that is, if the hood hangs forward on one side and back on the other, the hood is moved on the hinge to correct the misalignment at the nose. The parallel lines will fall in by themselves if the sheet metal is square. To align hood in an out-of-square opening, take a little out-of-parallel of the split lines and some misalignment at the front end panel. When the hood is moved fore or aft, on either side, it affects the hood and fender gap on all four corners of the hood. The final adjusting is done by the hinge pillar attachment. Try for parallel lines but, as a last resort, you can move one fender outboard and the opposite inboard and pick up enough gap in the hood line to make a good job out of a poor one. Check door swing to hood if this is done.

2. Front Alignment for Flushness to Fender and Front End Panel: Three adjustable bumpers are used for front end flushness. One is on the hood inner panel to the side of the hood latch opening, and one on each side of the upper tie bar on A-B-C-E Series and on each side of the hood panel on X Series. First lower the two outer bumpers to allow the hood to fall below the fenders. Set the bumper in the hood to fall below the fenders. Set the bumper in the hood panel to align the hood approximately 1/16 inch above the front end panel when the hood is lowered gently. The outer corners should now be approximately 1/8 inch low to fenders. If not, reform the nose of the hood to do so. Raise outer bumpers to flush hood to fender. This is done to put extreme pressure on outer corners and eliminate hood flutter. The center bumper only controls hood height at the center of the hood where hood is slammed.

3. Rear Vertical Alignment: If all component parts of fender mounting are correct, the hood hinge will pull the hood below the fender when the rear adjustable bumpers are lowered. If the rear of the hood does not fall low to the fenders, file the rear attaching hole of hinge to fender upward to bring the hood lower. If the hinges are slotted it will not be necessary to file. Raise the rear adjustable bumper to flush hood to fender. This pressure on the rear hood bumpers is necessary to eliminate hood flutter. In cases of tight hood to fender split lines, the fender bumpers may hold the hood high to fender. Carefully flatten bumper and surface until hood to fender split lines are even.

4. Hood Alignment: Move hood to right or left at front by hinge adjustment. Do not depend on the hood latch for hood alignment. The hood latch can, however, be adjusted sideways. If the hood latch is to be adjusted, care should

be taken not to damage the mechanism. Always check the secondary latch by use of the release lever to insure absolutely no binding. The latch itself can be checked by closing the hood. Always check hood position in relation to the windshield wipers to be sure there is adequate clearance for wiper operation.

Refer to Figures 8A-10, 8A-15, 8A-20 and 8A-25 for hood dimensions.

## MAJOR REPAIR

Refer to the 1975 Body Service Manual for H Series removal and installation procedures.

### HOOD REMOVAL AND INSTALLATION

#### X-A-B-C-E Series Removal

1. Support hood in extreme "up" position.
2. Place folded rags under rear corners of hood to prevent possible damage to fenders.
3. Scribe a line along each hinge edge so hood can be replaced in same position.
4. Remove two hood hinge to hood bolts from each side. See Figures 8A-1, 8A-2, 8A-3 and 8A-4.
5. Lift hood from car.

#### Installation

1. Install hood and secure to hinge with two bolts on each side.
2. Using scribe mark, align and tighten bolts to 25 lb.ft.

### HOOD HINGE SPRING REMOVAL AND INSTALLATION

#### X-A-B-C-E Series Removal

1. Insert Tool J-9214 through loop in forward end of spring with bend of tool approximately one inch from loop. Using inside corner formed by hinge as a pivot, unseat spring from hinge. See Figures 8A-1, 8A-2, 8A-4 and 8A-5.

2. Push tool forward, causing hood spring to slide clear of hinge.

#### Series Installation

1. Insert Tool J-9214 through loop in forward end of spring. Using hinge as pivot, seat spring into notch.

### HOOD HINGE REMOVAL AND INSTALLATION

#### X-A-B-C-E Series Removal

1. Prop hood in extreme "up" position and place folded rags under rear corners of hood to prevent possible damage to fenders.

2. Scribe position of hinge on hood and remove two hood hinge to hood bolts. See Figures 8A-1, 8A-2, 8A-3 and 8A-4.

3. Scribe position of hinge on fender on X and A Series, support and cowl on B-C Series, support on E Series.

4. Remove the 2 bolts (3 on B-C Series) -

1. Align hood hinge with scribe marks on body.
2. Install bolts but do not tighten.
3. Align hood with marks on hinge and install bolts but do not tighten and remove protective coverings.
4. Close hood and align flush.
5. Raise hood and tighten mounting bolts to 25 lb.ft.

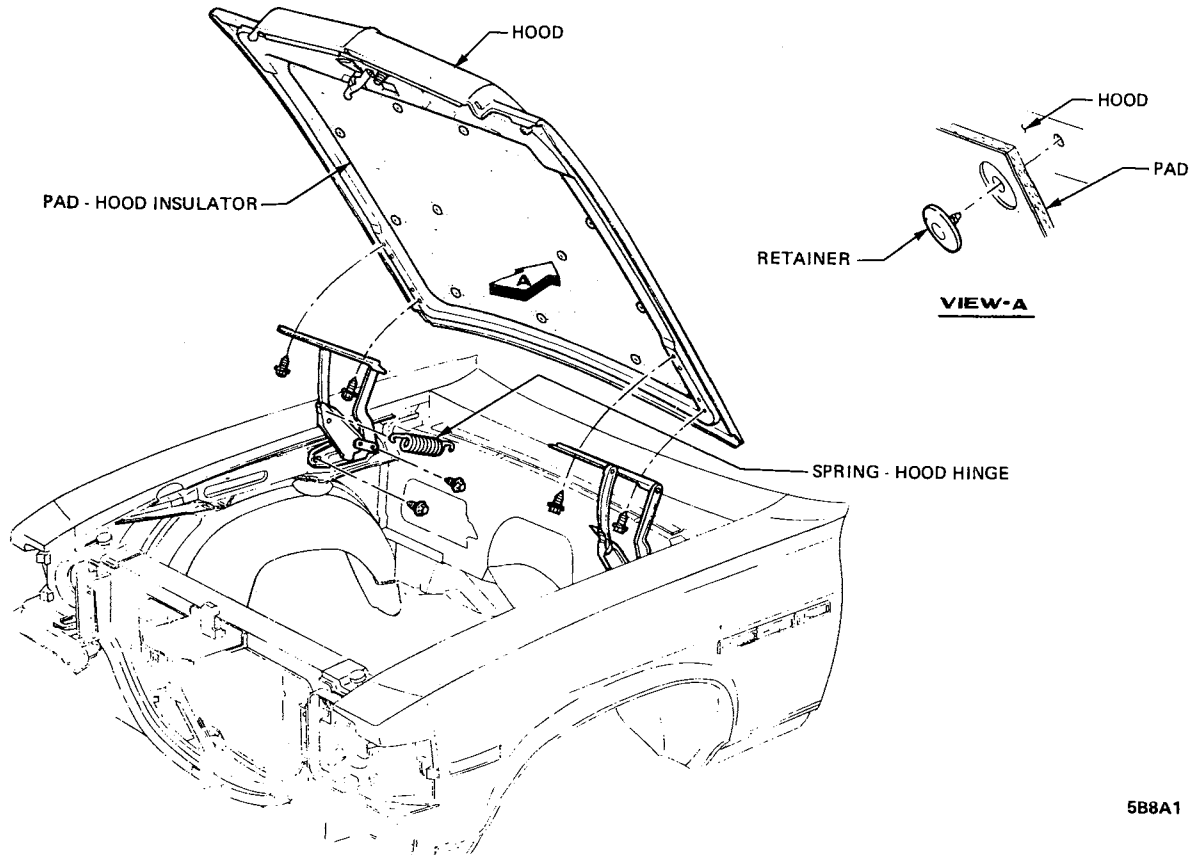

Figure 8A-1 X Series Hood

5B8A1

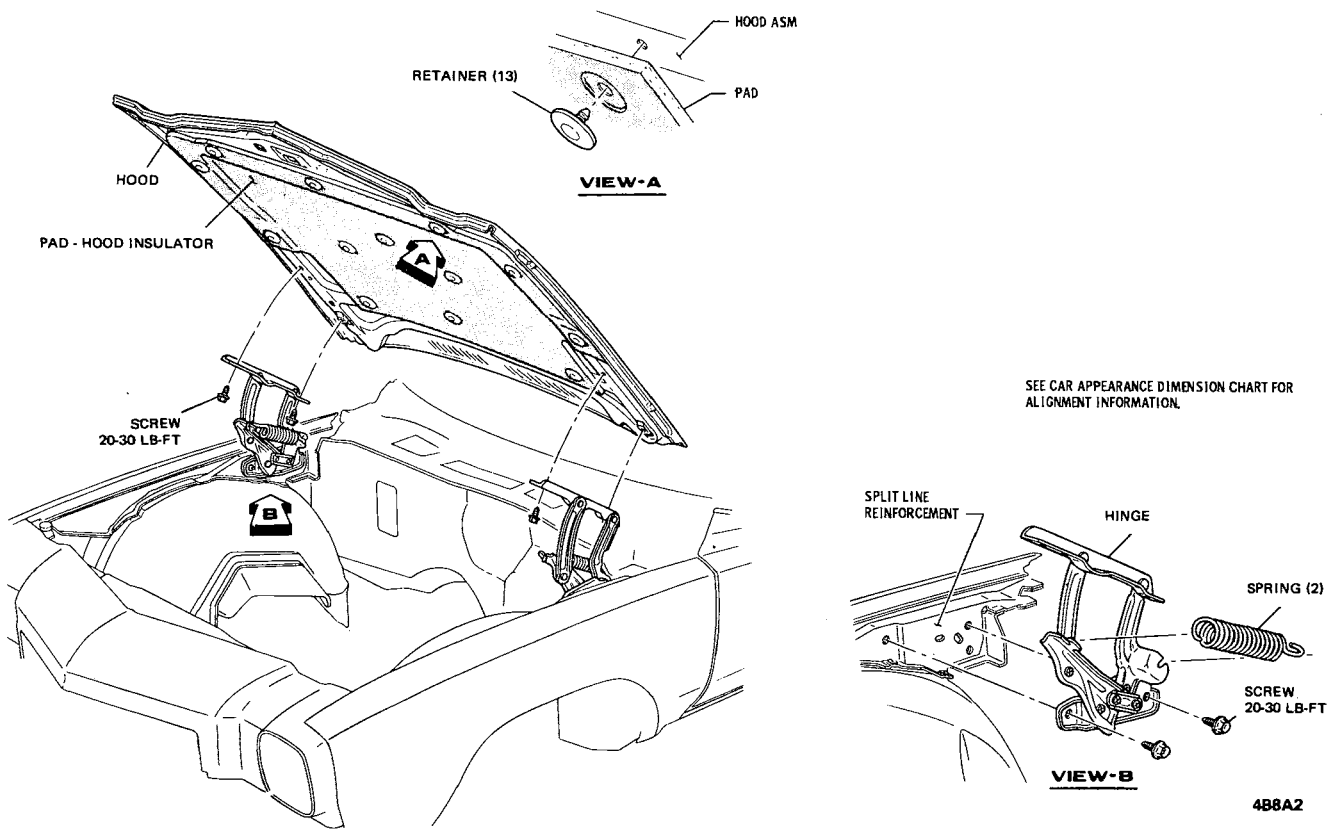

Figure 8A-2 A Series Hood

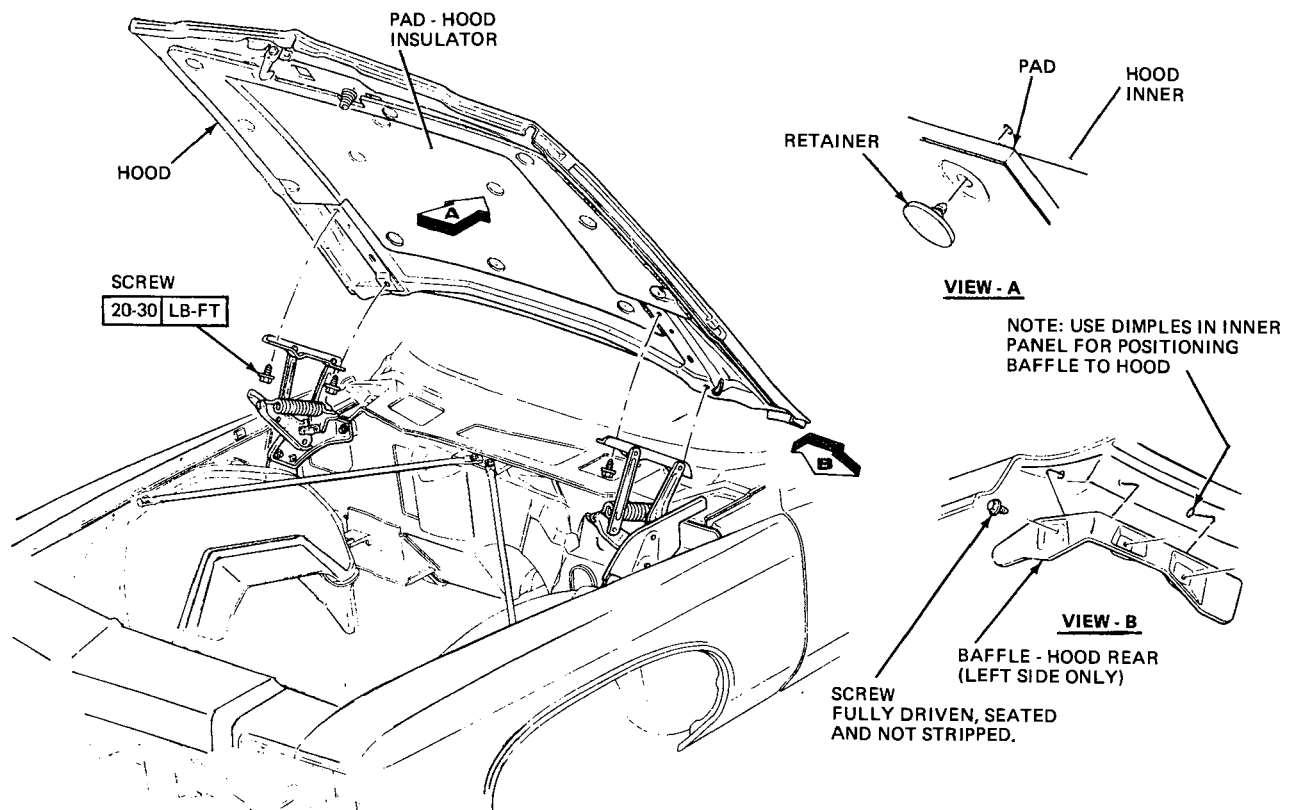

Figure 8A-3 B-C Series Hood

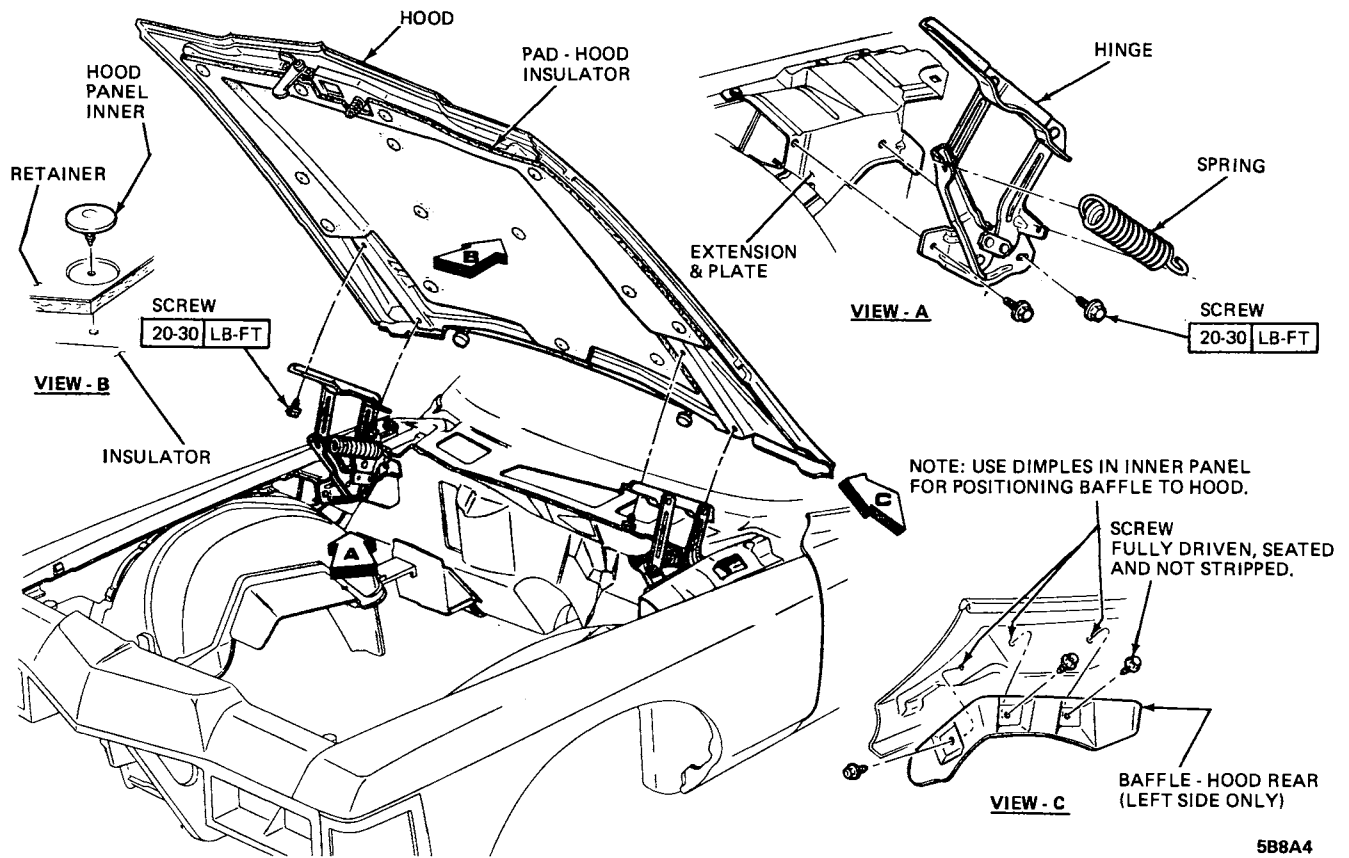

Figure 8A-4 E Series Hood

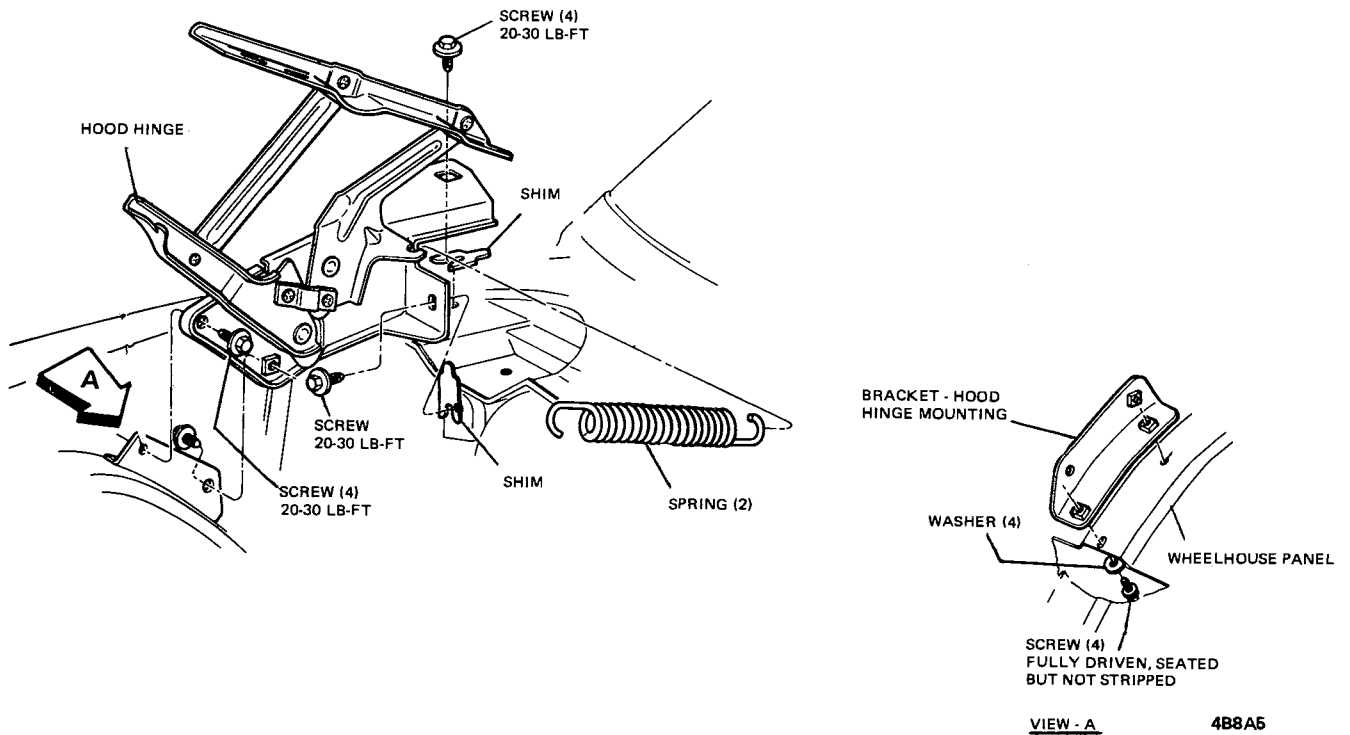

Figure 8A-5 B-C Series Hood Hinge Spring

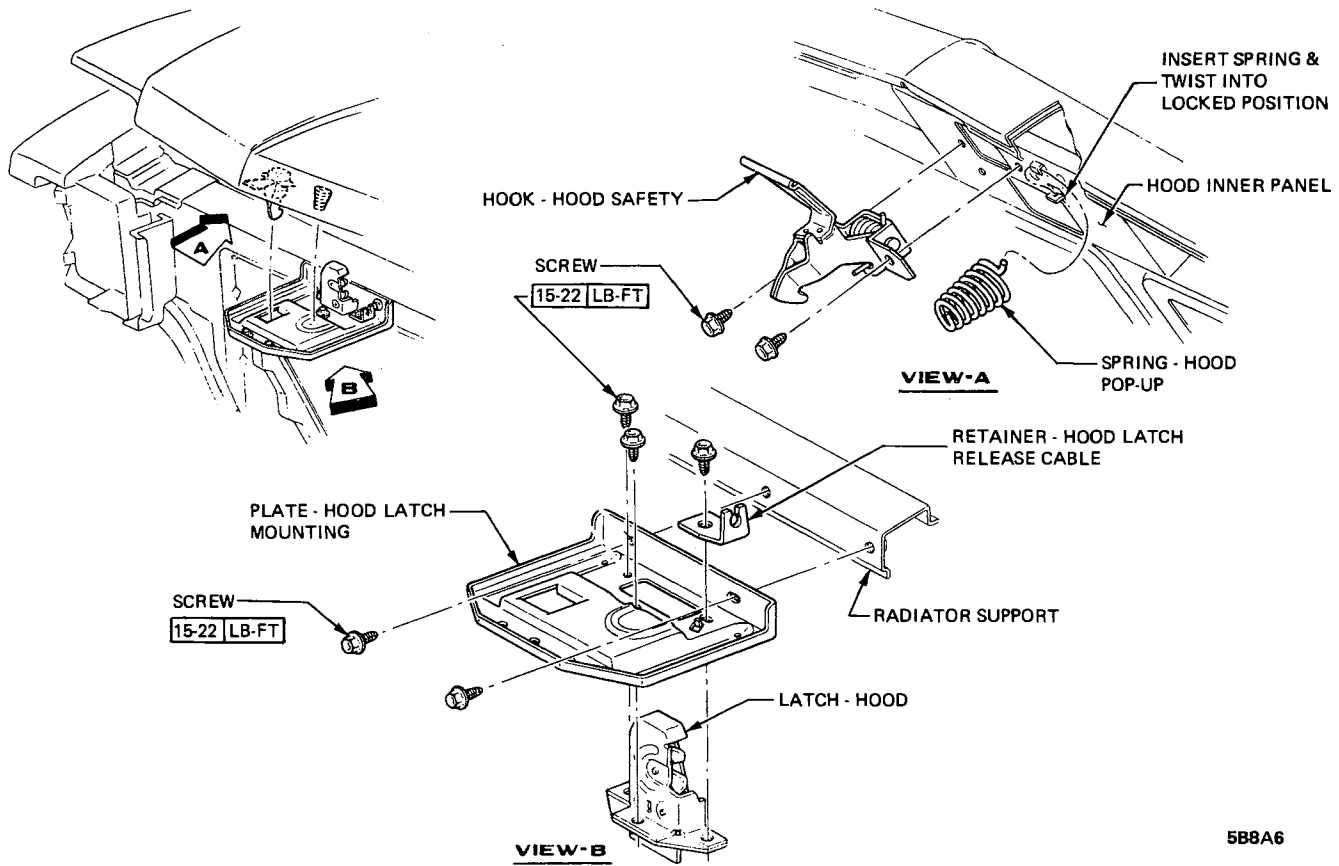

Figure 8A-6 X Series Hood Latch

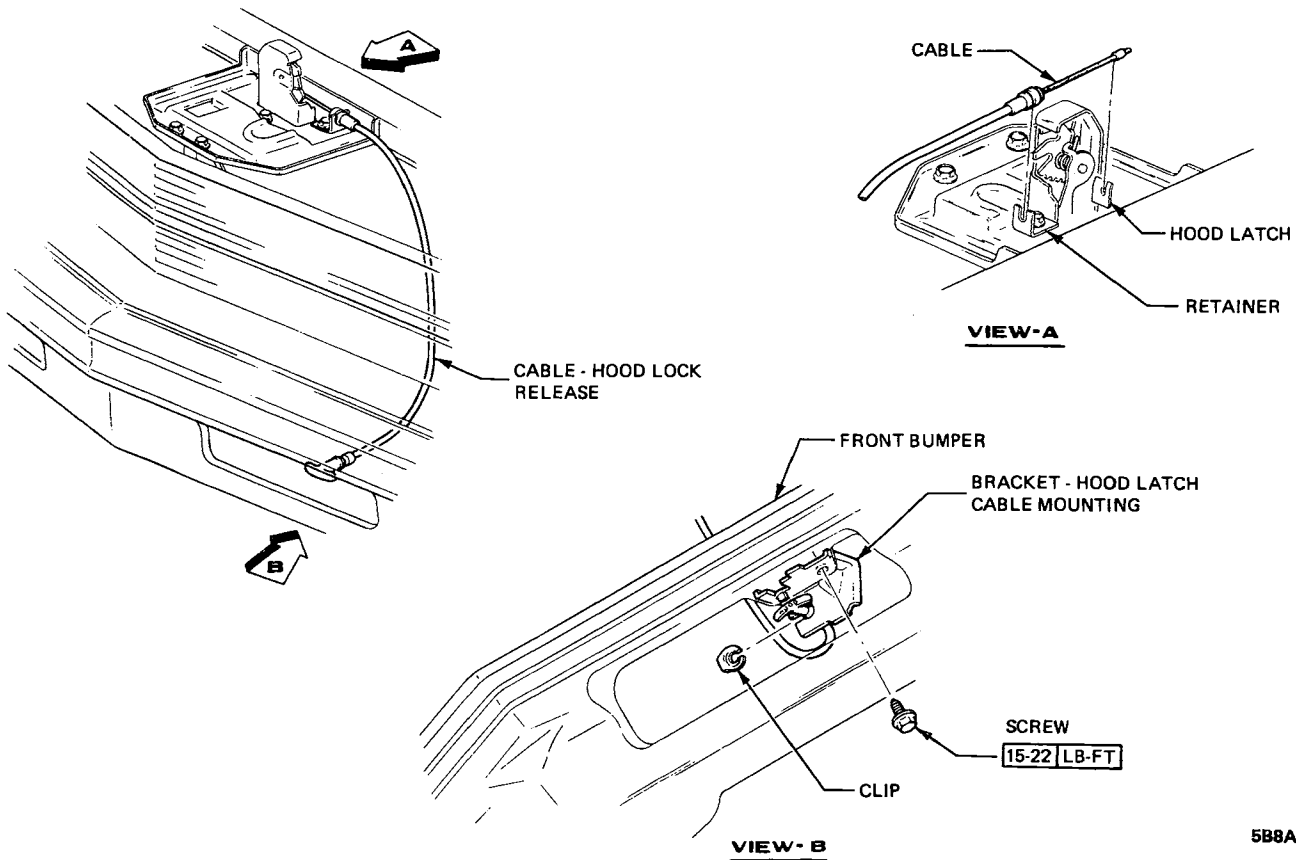

Figure 8A-7 X Series Hood Release Cable

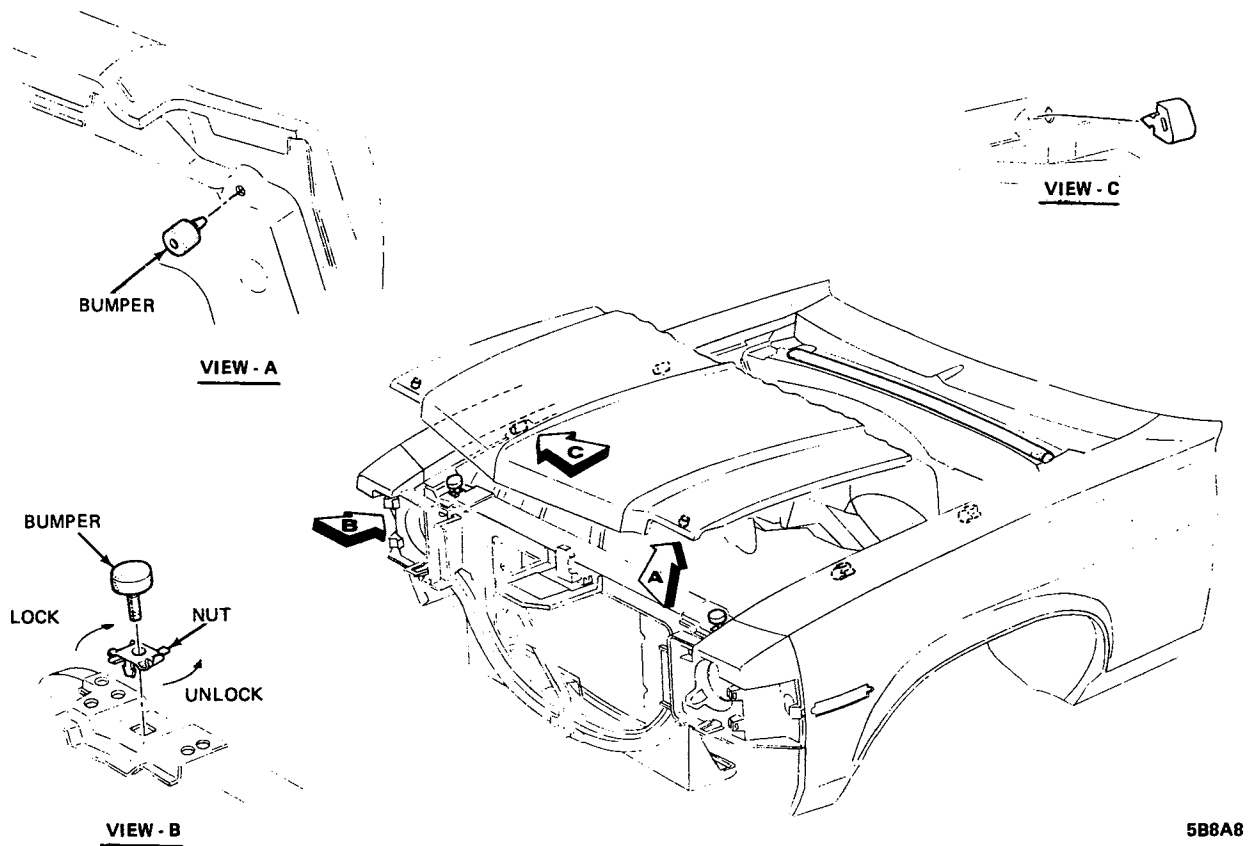

Figure 8A-8 X Series Hood Bumpers

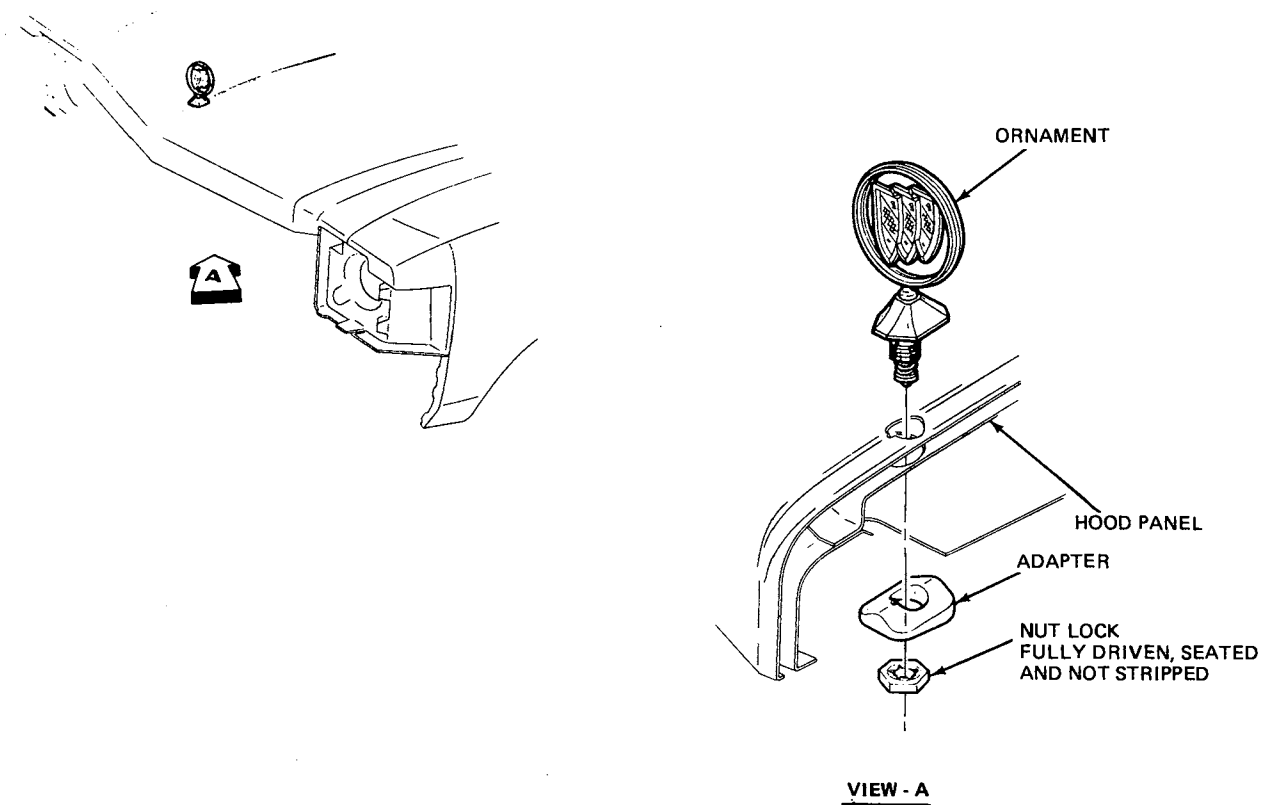
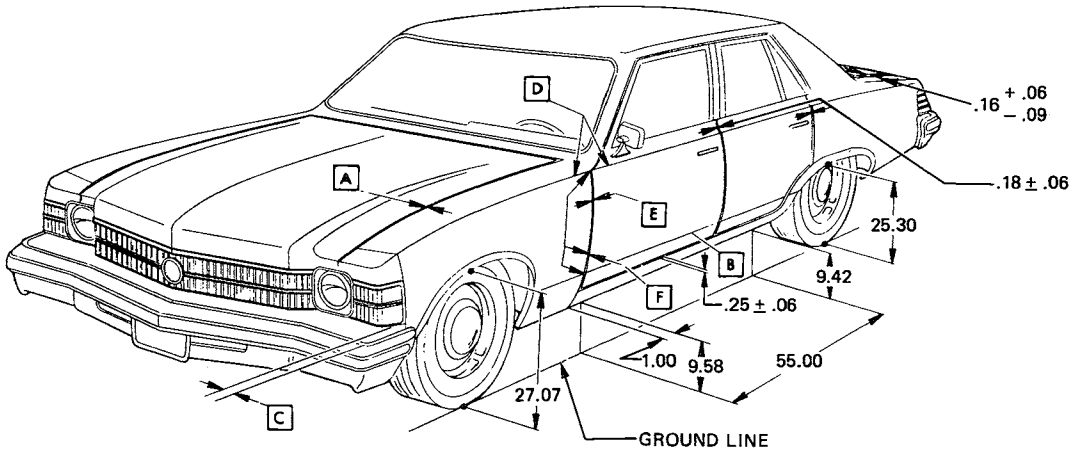

Figure 8A-9 X Series Hood Ornamentation

- A .100 TO .200 MUST BE PARALLEL WITHIN .06.
- B LOWER CHARACTER LINE.
- C SPACE FRONT & REAR BUMPERS EQUALLY TO SHEET METAL - BOTH SIDES.
- D FENDER PEAK MUST BE FLUSH TO .060 HIGH ALIGNED WITH DOOR.
- E  $.23 \pm .06$  MUST BE PARALLEL WITHIN .06.
- F FENDER .040 IN 10.060 OUT - FROM DOOR AT TOP TO LOWER CHARACTER LINE.



CURB DIMENSIONS SHOWN.  
 OVERALL LENGTH LESS BUMPER & RELATED ATTACHING PARTS.  
 COUPES & SEDANS 191.52. **5B8A10**

Figure 8A-10 X Series Hood Dimensions

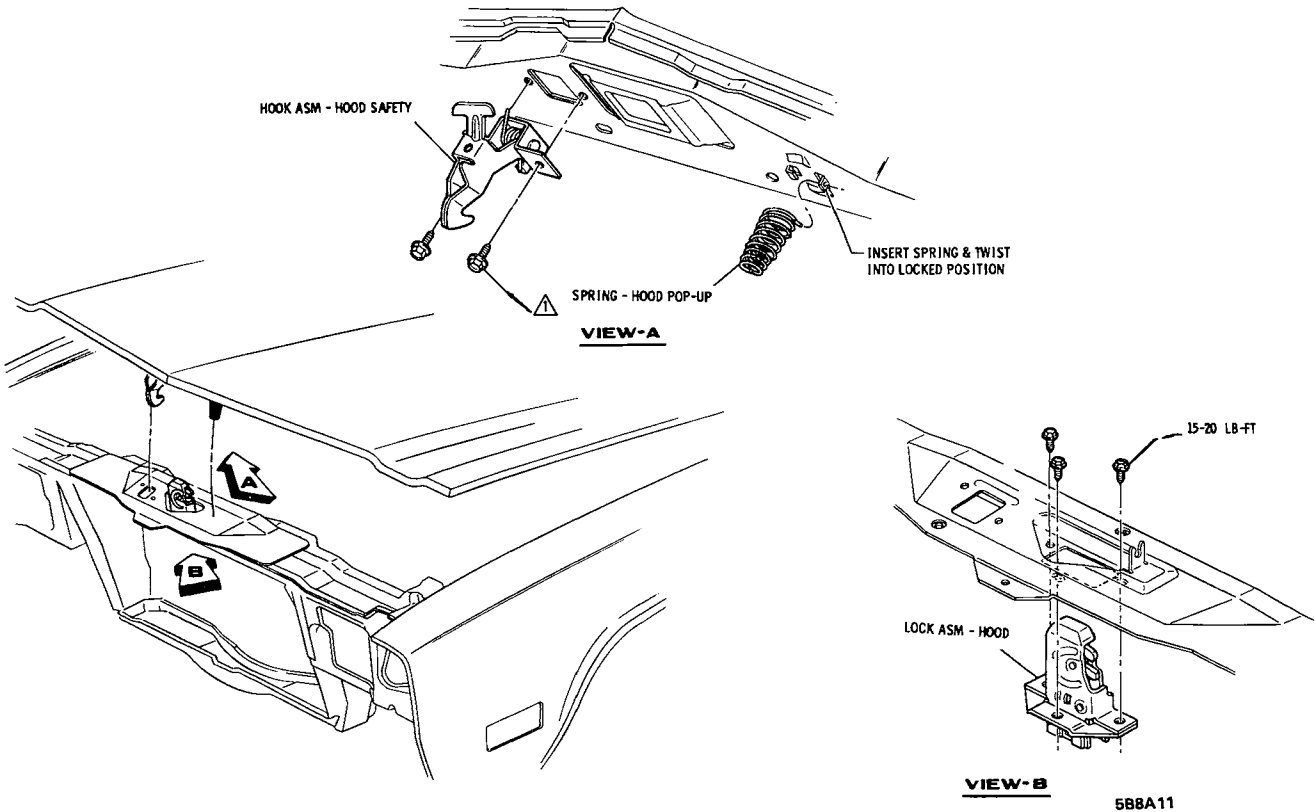

Figure 8A-11 A Series Hood Latch

**5B8A11**



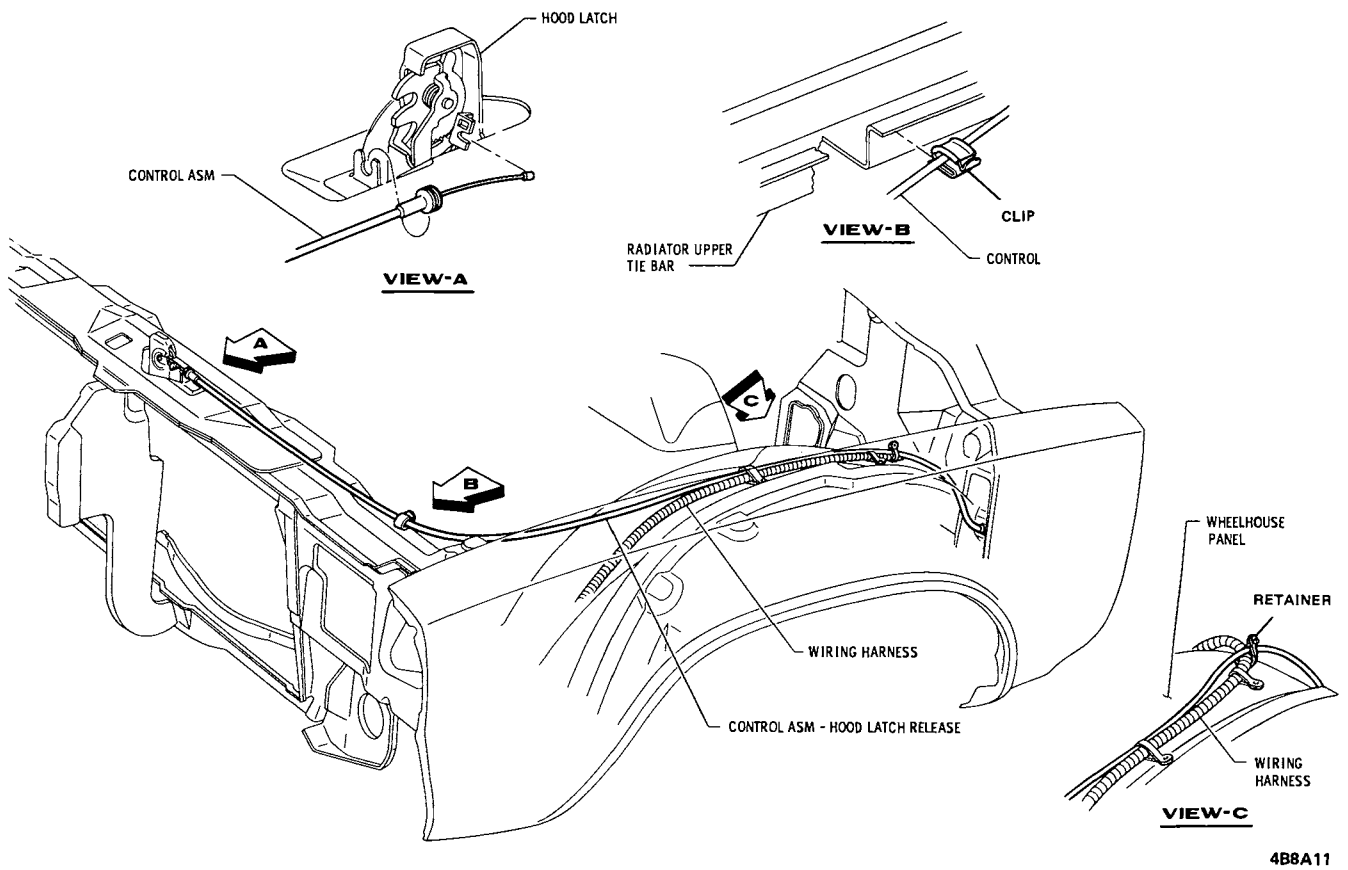

Figure 8A-12 A Series Hood Release Cable

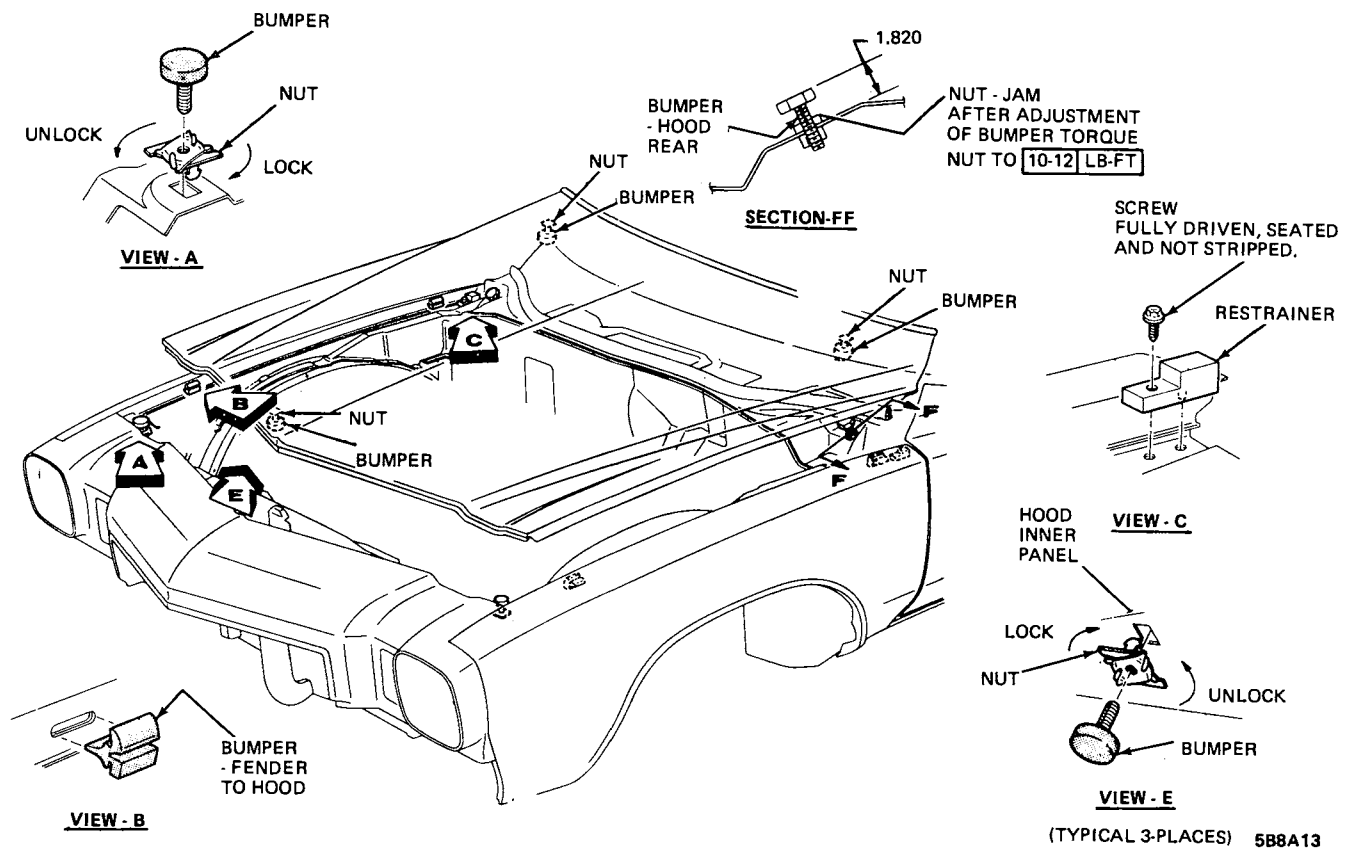
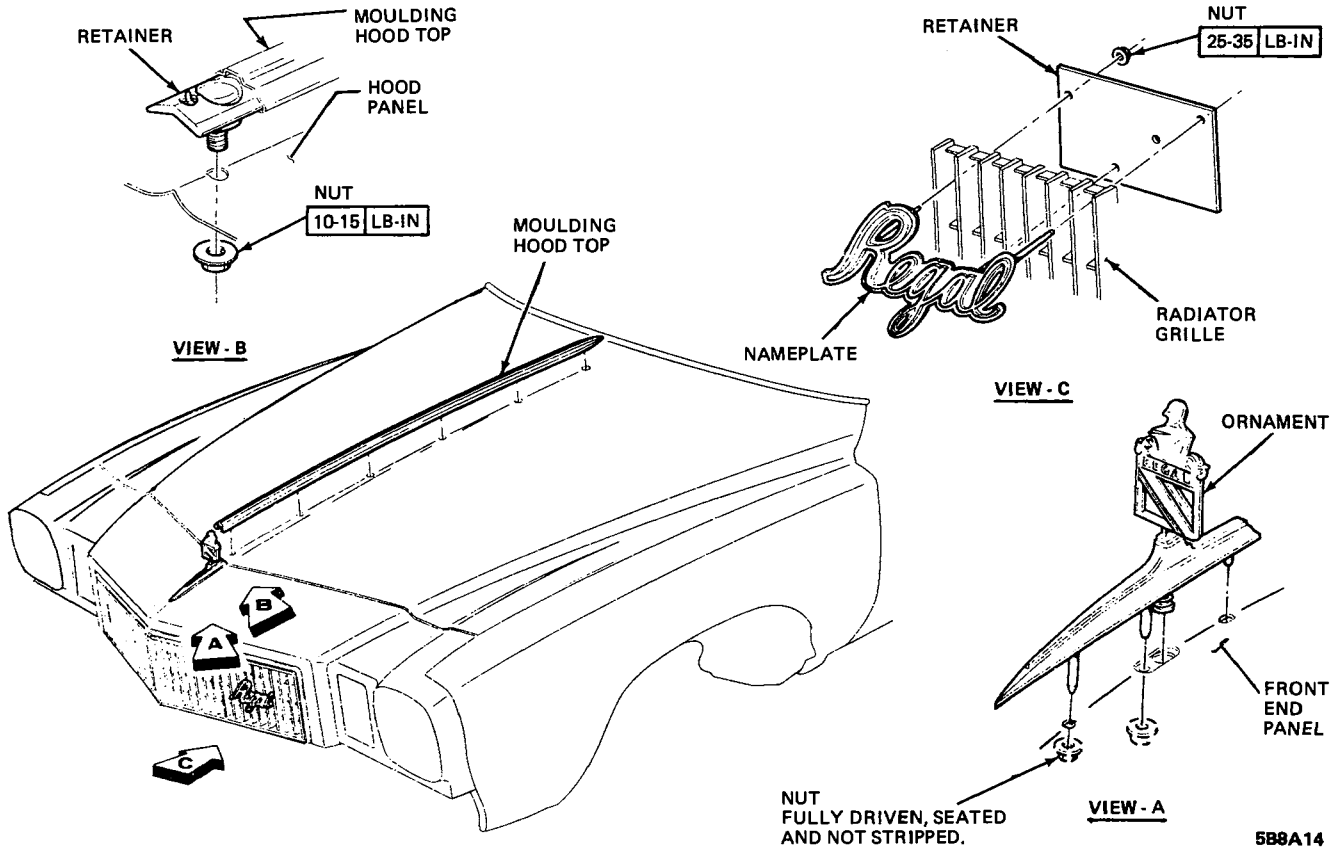
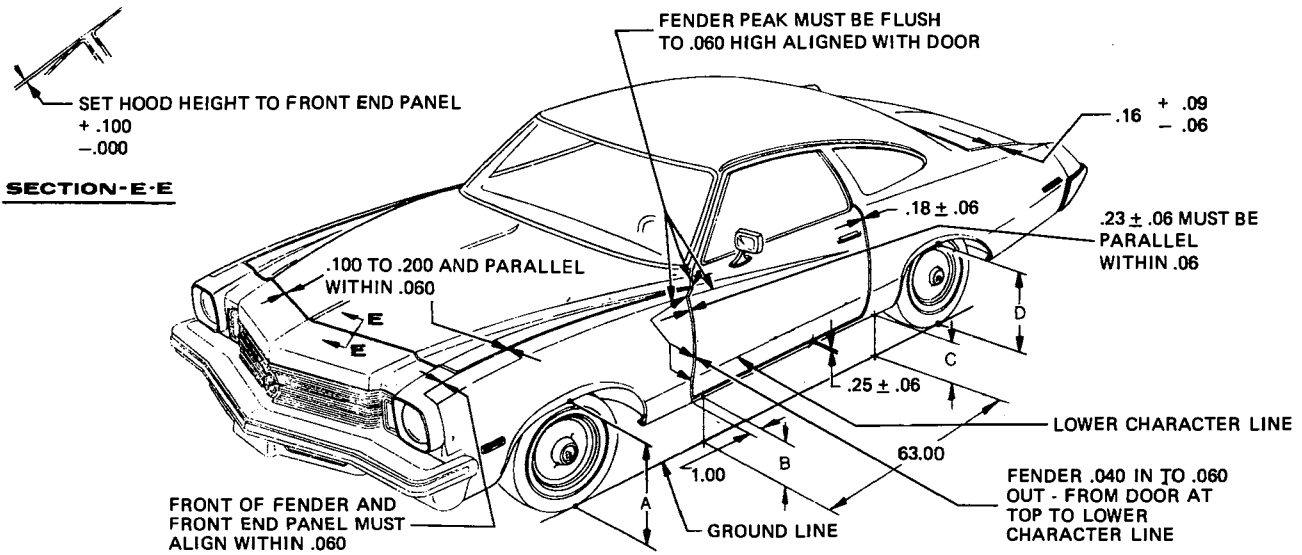

Figure 8A-13 A Series Hood Bumpers



588A14

Figure 8A-14 A Series Hood Moldings



SECTION-E-E

BODY STYLES				
DIM.	CENTURY	CENTURY LUXUS	REGAL	WAGON
	CURB	CURB	CURB	CURB
A	27.70	27.70	27.70	27.67
B	10.20	10.20	10.20	10.49
C	10.09	10.09	10.09	10.63
D	25.36	25.36	25.36	26.05

DIMENSIONS DO NOT INCLUDE MOULDINGS

OVERALL LENGTHS LESS BUMPER & RELATED ATTACHING PARTS:

CENTURY COUPE	202.90
CENTURY SEDAN	206.90
REGAL COUPE	205.38
REGAL SEDAN	209.38
CENTURY WAGON	212.04

588A15

Figure 8A-15 A Series Hood Dimensions

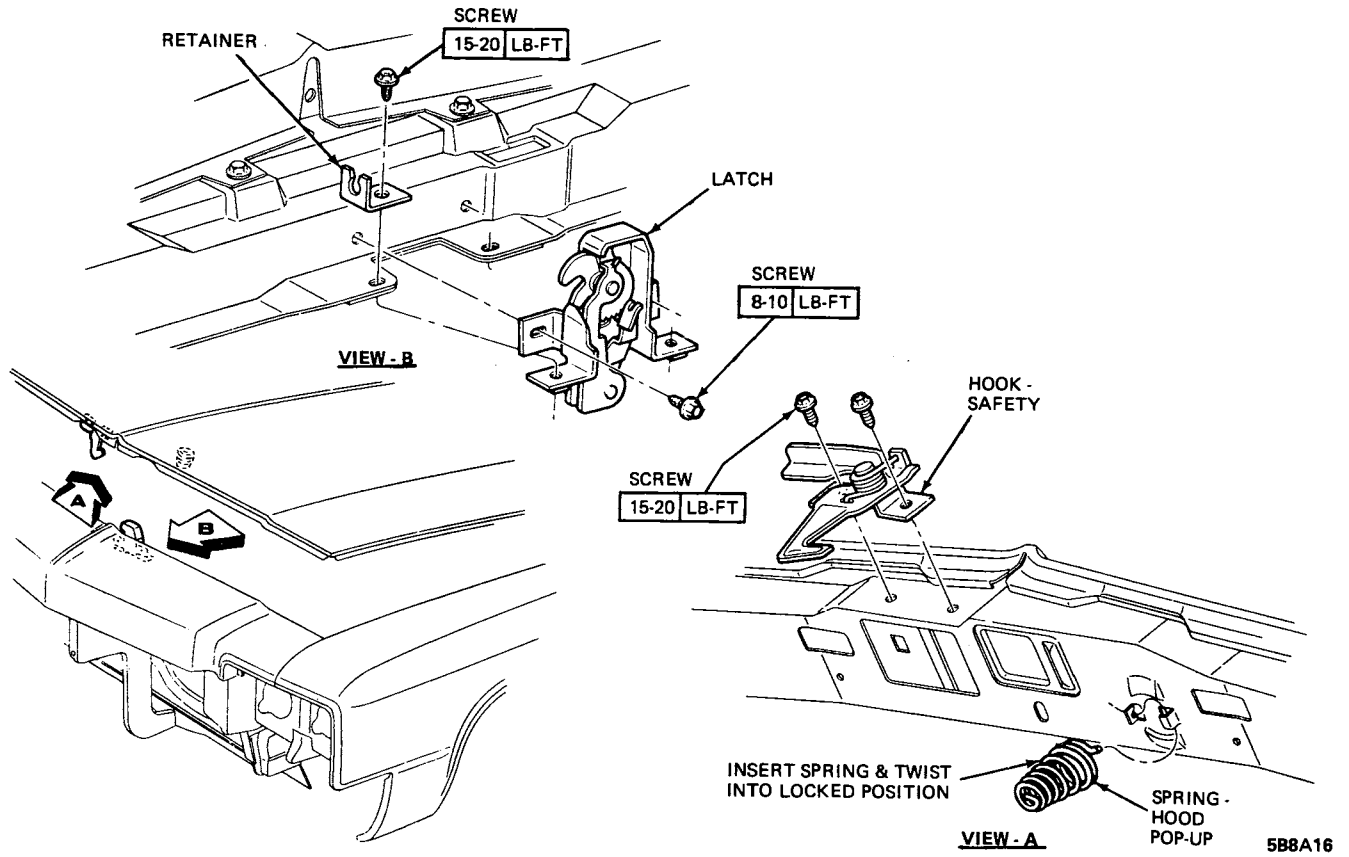

Figure 8A-16 B-C Series Hood Latch

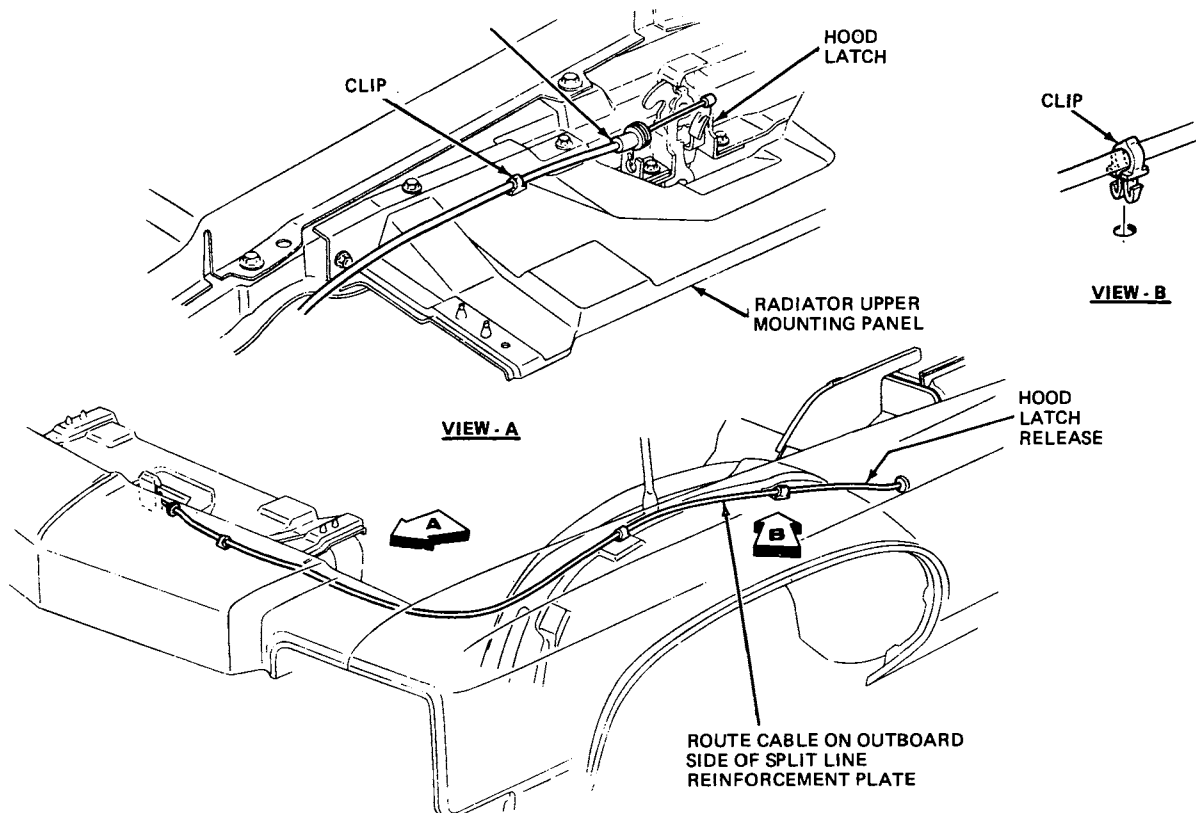

Figure 8A-17 B-C Series Hood Release Cable

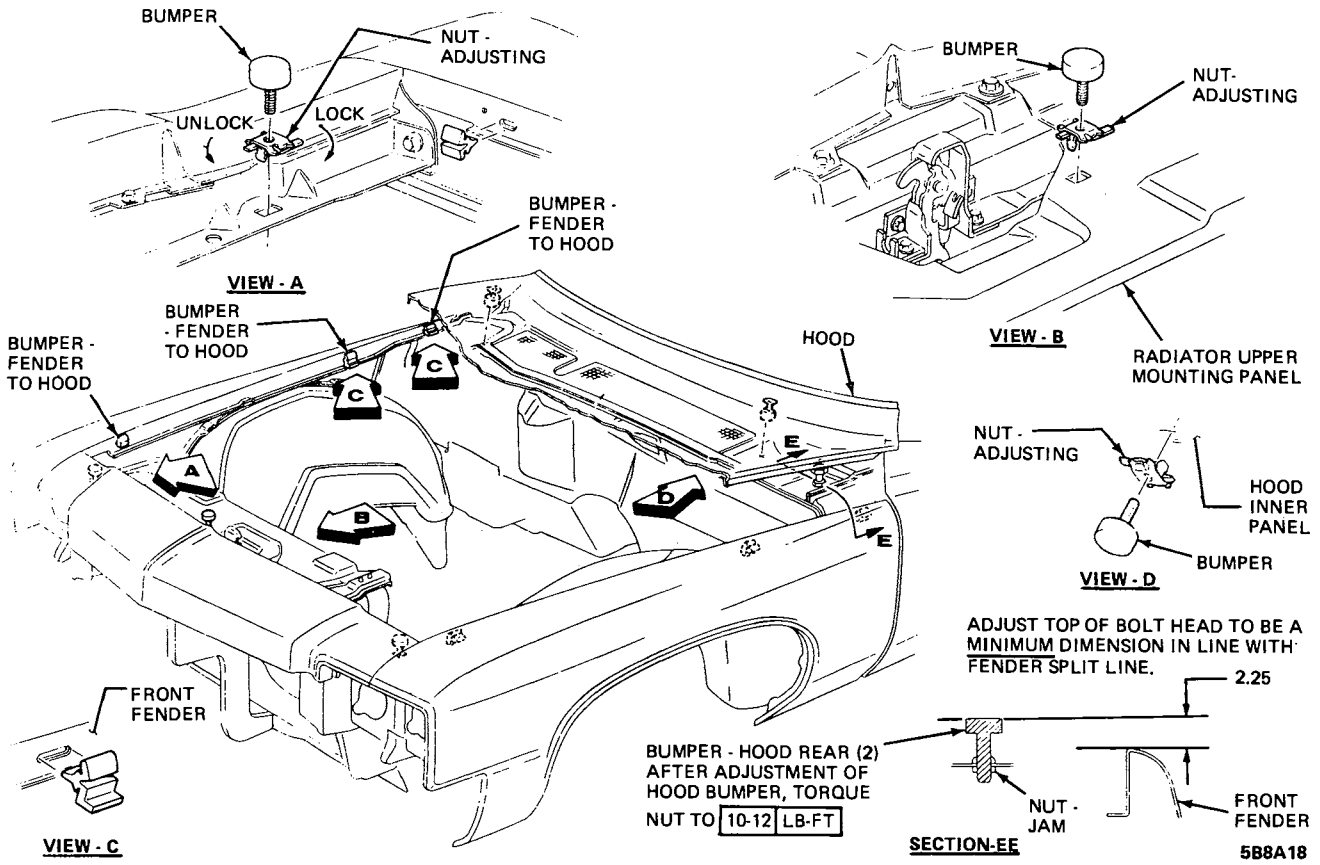

Figure 8A-18 B-C Series Hood Bumpers

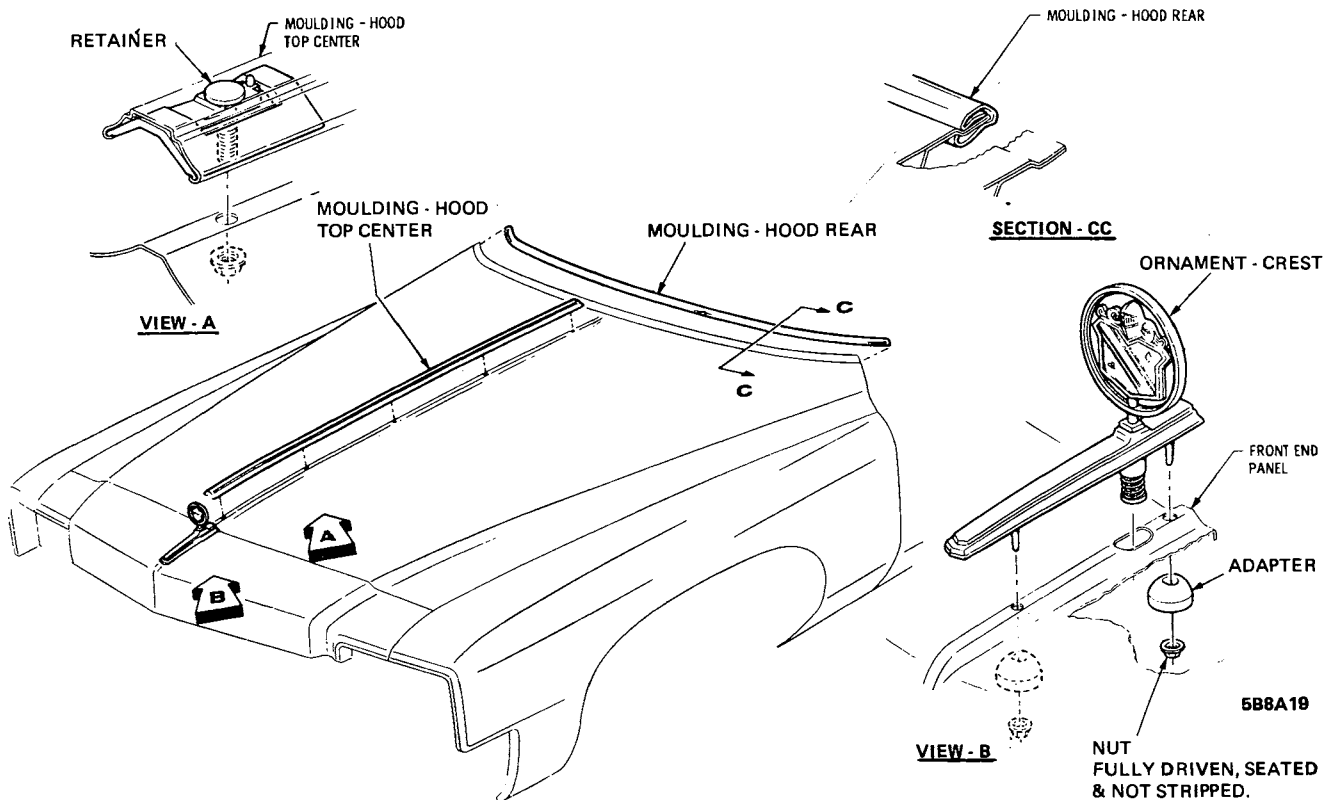

Figure 8A-19 B-C Series Hood Moldings

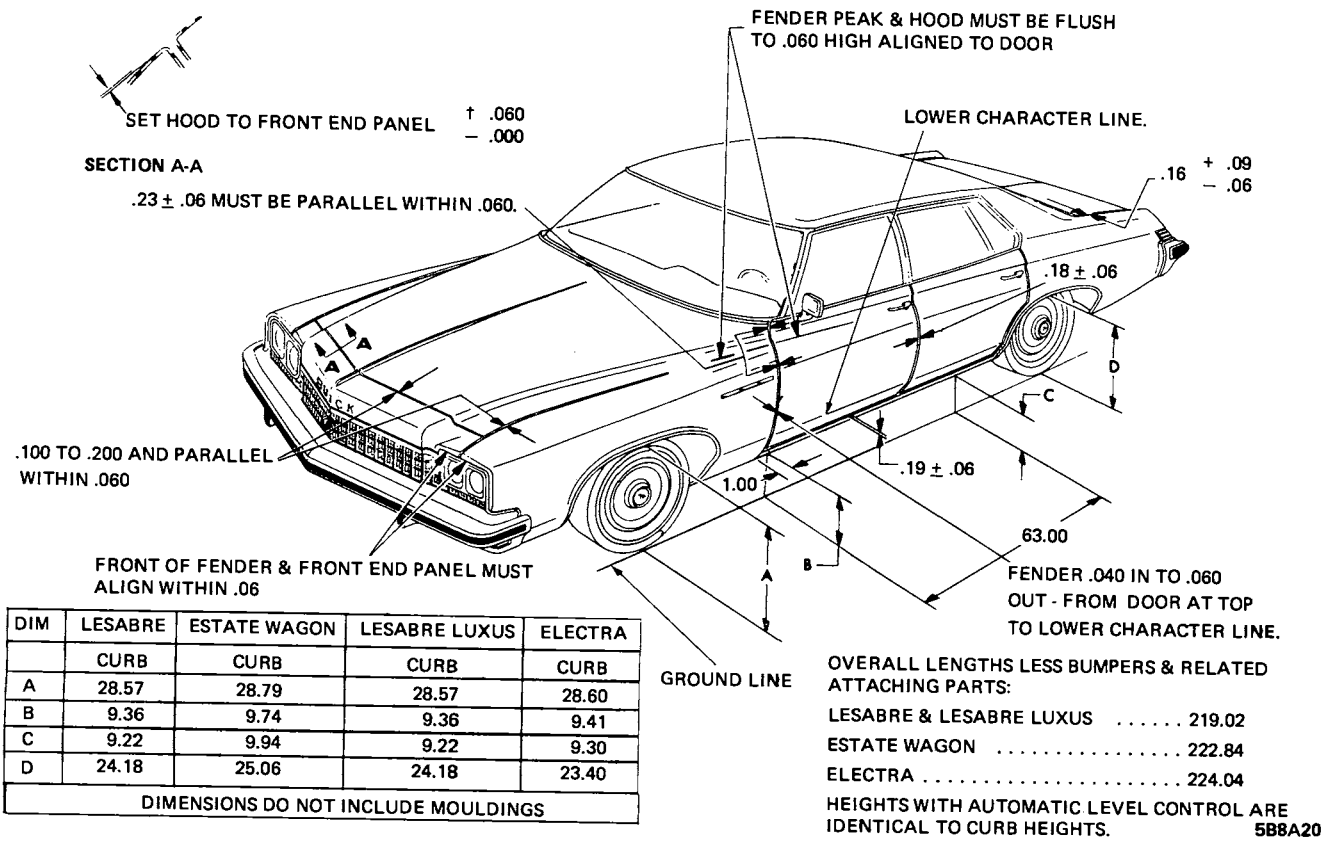

Figure 8A-20 B-C Series Hood Dimensions

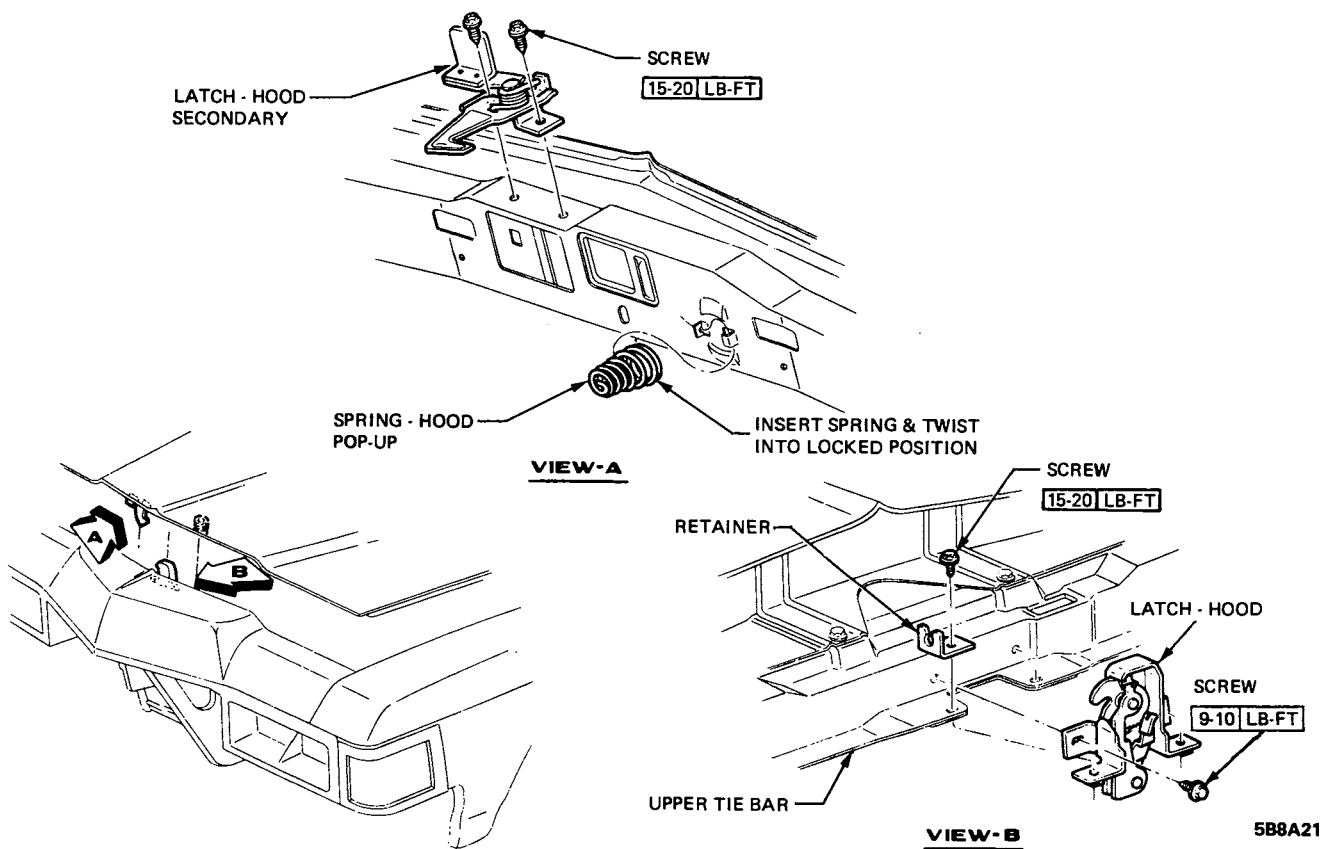

Figure 8A-21 E Series Hood Latch

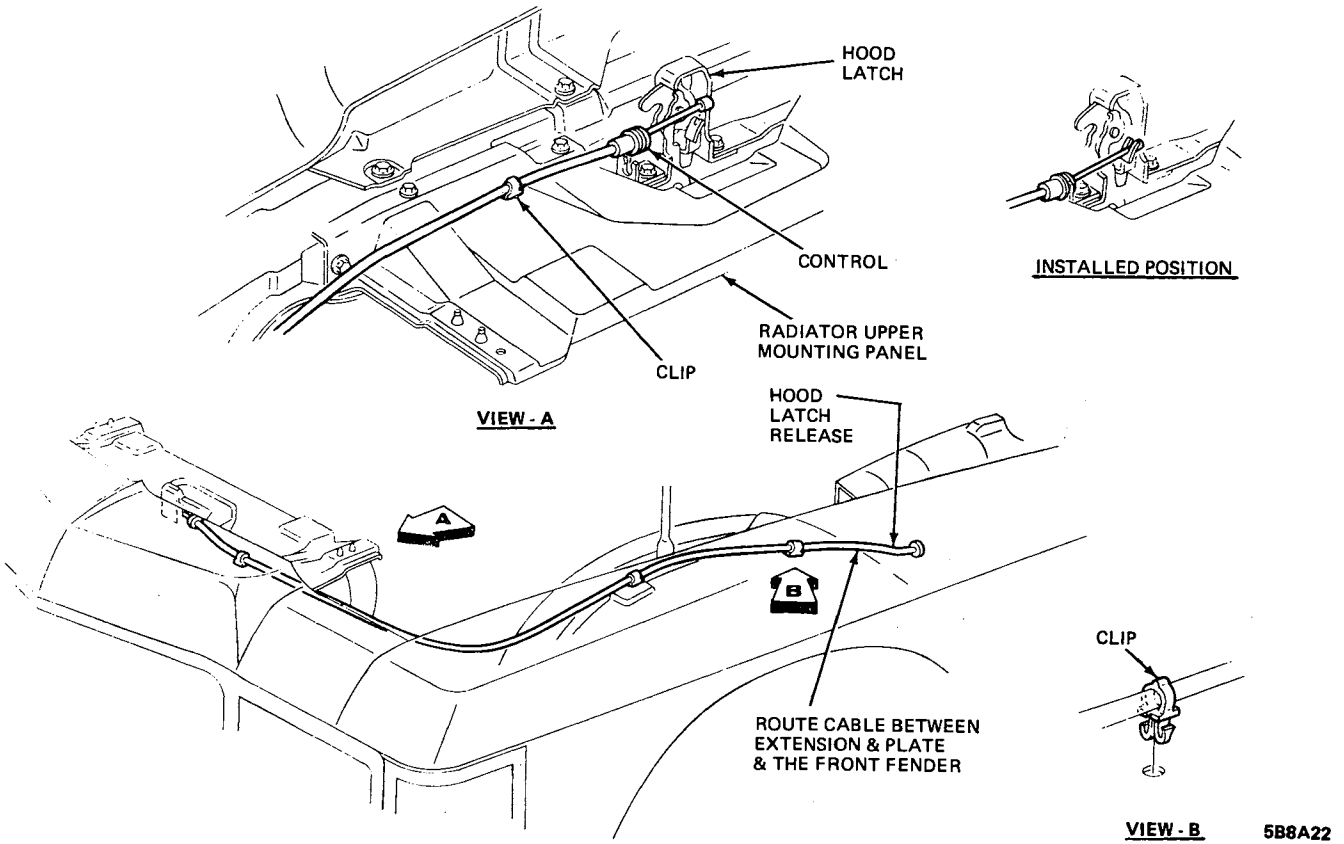

Figure 8A-22 E Series Hood Release Cable

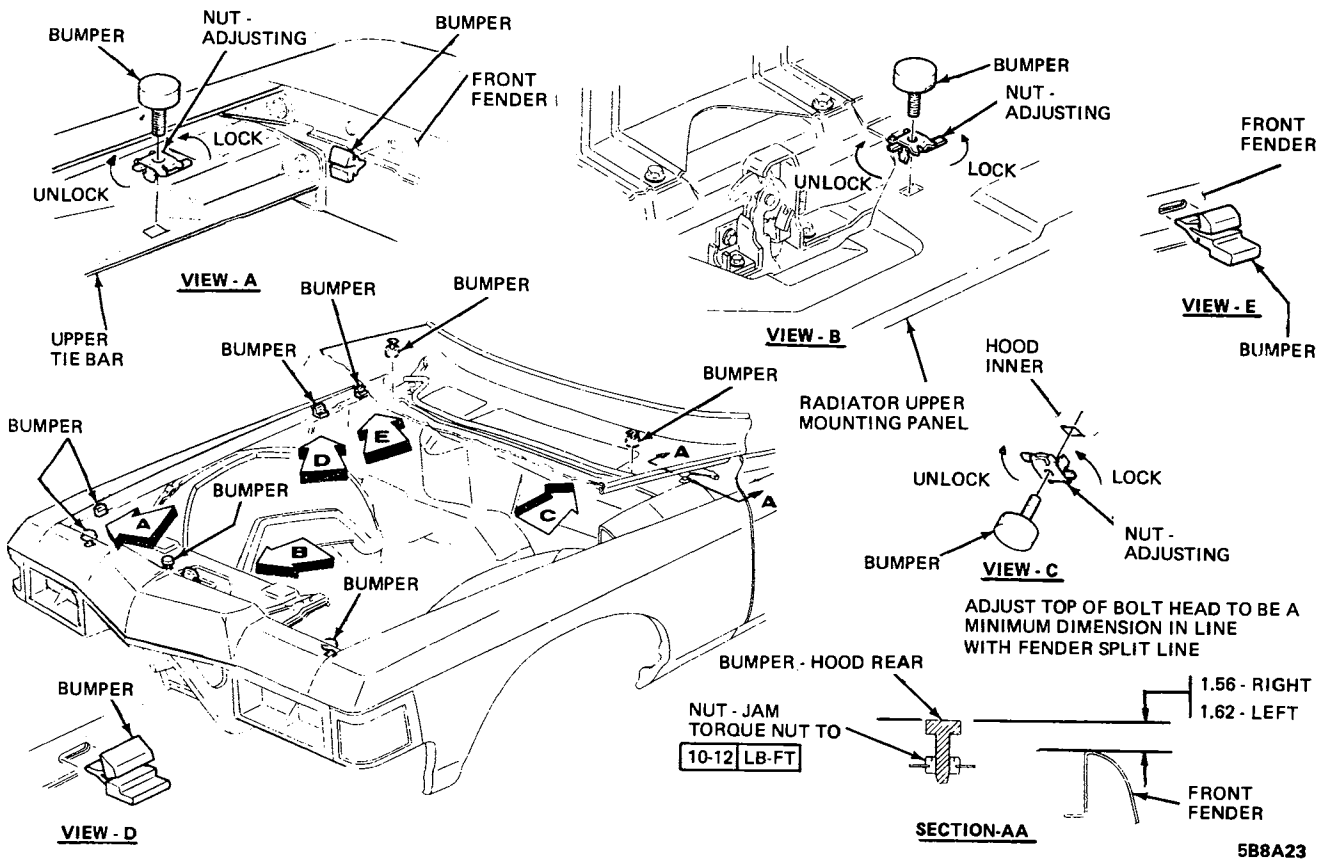
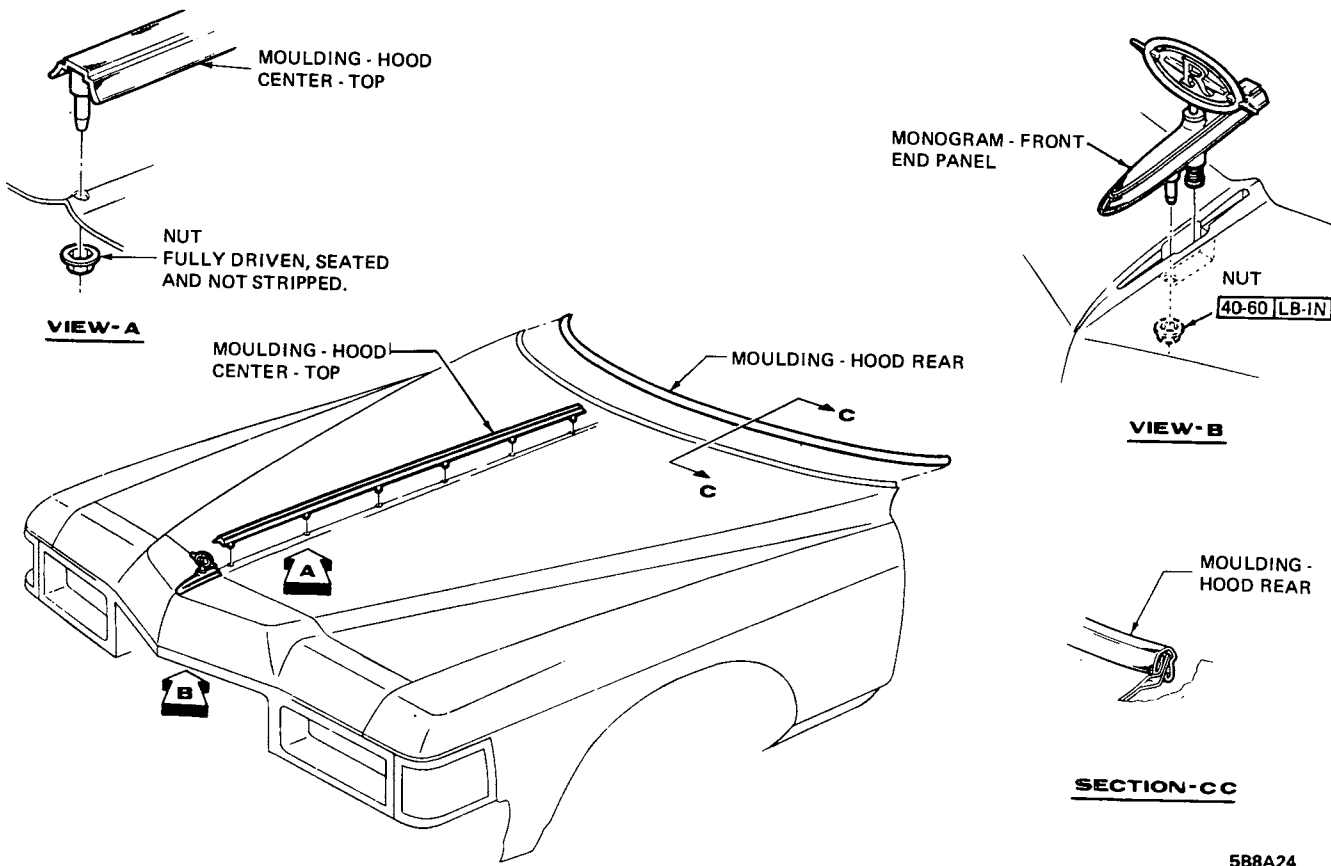
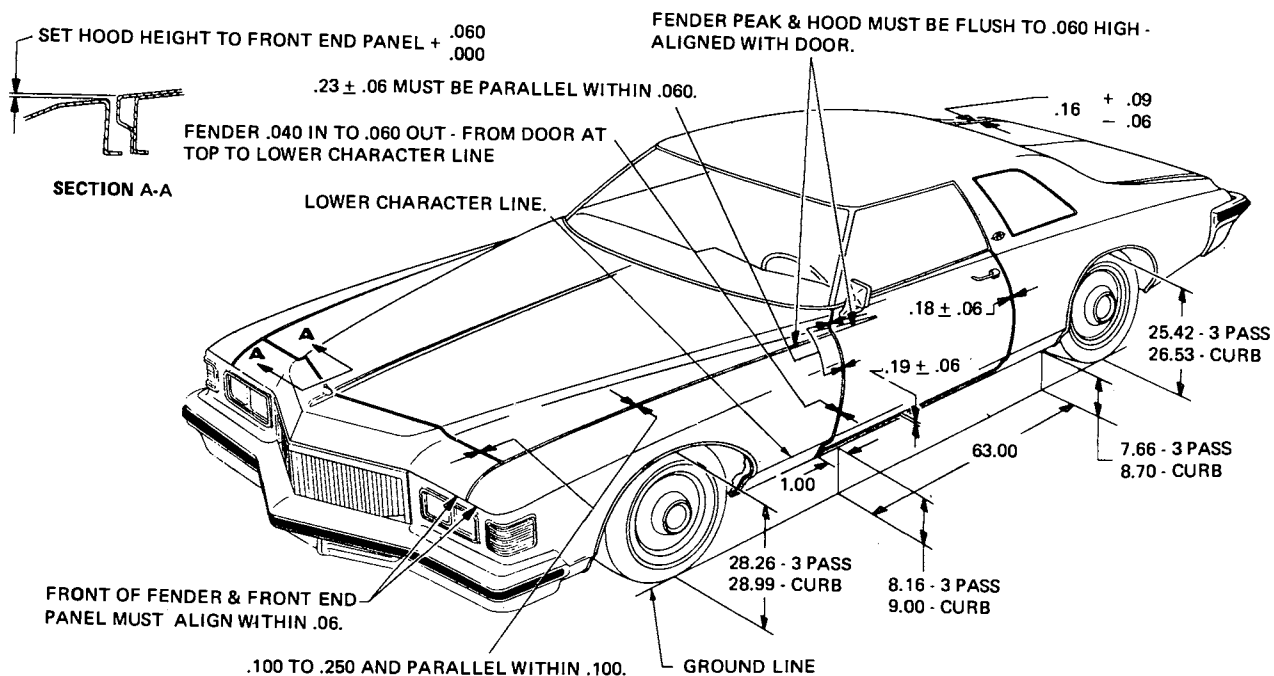

Figure 8A-23 E Series Hood Bumpers



5B8A24

Figure 8A-24 E Series Hood Moldings



OVERALL LENGTH LESS BUMPERS & RELATED ATTACHING PARTS - 214.01.  
 MOULDINGS NOT INCLUDED IN DIMENSIONS.  
 HEIGHTS WITH AUTOMATIC LEVEL CONTROL ARE IDENTICAL TO CURB HEIGHTS.

5B8A25

Figure 8A-25 E Series Hood Dimensions