

FRONT END ALIGNMENT

CONTENTS

DESCRIPTION AND OPERATION:	
Front End Alignment	3D-1
DIAGNOSIS: (Not Applicable)	
MAINTENANCE AND ADJUSTMENTS:	
Front End Alignment	3D-1
MAJOR REPAIR: (Not Applicable)	
SPECIFICATIONS:	
Front End Alignment Specifications	3D-6

DESCRIPTION AND OPERATION

FRONT END ALIGNMENT

Wheel alignment is the process of adjusting the position of the front suspension and wheels in order to attain proper vehicle handling characteristics and the least steering effort with a minimal amount of tire wear.

Wheel and tire balance has an important effect on steering and tire wear. If wheels and tires are out of balance, "shimmy" or "tramp" may develop causing tires to wear unevenly and give the erroneous impression that the wheels are not in proper alignment. For this reason, the wheel and tire assemblies should be known to be in proper balance before assuming that the front suspension is out of alignment.

With the type of front suspension used, the toe-in adjustment is usually more important than caster and camber as far as tire wear is concerned.

In the majority of cases, services consisting of inflating tires to specified pressure and interchanging tires at recommended intervals, balancing all wheels and tires, adjusting steering gear and setting toe-in correctly will provide more improvement in car handling and tire wear than will front end alignment adjustments.

The correct use of accurate front end alignment equipment is essential to determine whether front suspension parts have been damaged, and to obtain correct alignment settings after new parts have been installed.

MAINTENANCE AND ADJUSTMENTS

FRONT END ALIGNMENT

Inspection Before Checking Front Wheel Alignment

Before making any adjustment affecting caster, camber, toe-in, theoretical king pin inclination, or steering geometry, the following checks and inspections should be made to insure correctness of alignment equipment readings and alignment adjustments.

1. Front tires should have approximately the same wear and all tires must be inflated to specified pressure.
2. Check front wheel bearings for looseness and adjust if necessary.

3. Check for run-out of wheels and tires.

4. Check wheels and tires for balance and correct if out-of-balance.

5. Check for looseness at ball joints, tie rod ends, and steering relay rods; if found excessive, it must be corrected before alignment readings will have any value.

6. Check trim height; if out of limits, correct with shims or replace spring. Consideration must be given the undercoating, dirt, etc. Vehicle should be at curb or free height when an alignment operation is performed. (All excess equipment, such as tool boxes, fishing or golfing equipment should be removed from the vehicle.) The vehicle should have a full tank of fuel.

Good judgment should be exercised before replacing a spring when car trim height is only slightly out of limits. Spring replacement under conditions of excessive weight as mentioned above will accomplish little and must be accompanied by shimming to obtain satisfactory results. Front and rear shims are available through the Parts Department.

7. It is advisable to check the condition and accuracy of any equipment being used to check front end alignment and to make certain that instructions of the manufacturer are thoroughly understood and followed.

Checking Caster and Camber Settings

Caster is the forward or rearward tilt of the steering knuckle pivot centerline from true vertical as viewed from the side of the vehicle. If the top of the steering knuckle pivot centerline is tilted forward of true vertical, it is called "negative caster." If the top of the steering knuckle pivot centerline is tilted rearward of true vertical, it is called "positive caster."

Camber is the inward or outward tilt of the top of a wheel from true vertical as viewed from the front of the vehicle. If the top of a wheel is tilted outward from true vertical, it has "positive camber." If the top of a wheel is tilted inward from true vertical, it has "negative camber."

Since caster and camber settings are both adjusted in the same locations, both of these settings must be checked before changing shims or cam position.

Regardless of equipment used to check caster and camber, the car must be on level surface both transversely and fore and aft.

When alignment equipment is used which bears against the tire or wheel rim to obtain readings, it is very essential that the tires or wheels be checked for lateral run-out.

Caster and camber readings must be taken at points on the wheels which have no run-out or which lie in the same plane. Caster and camber should be within the service limits shown. Note that the caster angles at both front wheels need not be exactly the same but must be within 1 degree of each other. Likewise, the camber angle on the left must be within specifications of the right. If caster and camber are not within the specified limits, adjust in the following manner.

H Series Caster and Camber Adjustment

Caster and camber adjustments are made by rotating, or changing the position of the cam bolts. The front cam adjusts the camber setting and the rear cam adjusts the caster setting. The lower control arm is designed so that the camber setting should be made first. In other words: adjust camber, then caster, then toe-in.

The front cam tends to move the control arm in or out with respect to the vehicle. This movement will change camber.

The rear cam tends to move the control arm fore or aft with respect to the vehicle. This movement will change caster.

Camber Adjustment

Camber angle is adjusted by loosening the front lower control arm pivot nut and rotating the cam until proper setting is reached. This eccentric cam action will move the lower control arm in or out thereby varying the camber. Hold the cam bolt head while tightening the nut.

Caster Adjustment

Caster angle is adjusted by loosening the rear lower control arm pivot nut and rotating the cam until proper setting is reached. This eccentric cam action will tend to move the lower control arm fore or aft thereby varying the caster.

Hold the cam bolt head while tightening the nut. Recheck camber after setting caster.

X-A-B-C-E Series Caster and Camber Adjustment

On A Series the alignment shims are installed from the bottom. Count shims before loosening to aid installation.

For caster and camber adjustment purposes, use the following guide:

1. To increase camber only - (More positive) Remove and equal amount of shims from front and rear bolts.
2. To decrease camber only - (Less positive) add an equal amount of shims to front and rear bolts.

3. To increase caster only - (More positive) Remove an amount of shims from front bolt and add an equal amount of shims at rear bolt.

4. To decrease caster only - (Less positive) Add an amount of shims at the front bolt and remove an equal amount of shims from the rear bolt.

5. To increase caster and camber at the same time - remove an amount of shims *at front bolt only*.

6. To decrease caster and camber at the same time - add an amount of shims *at front bolt only*.

The following guide lines will help you select and correctly shim with minimum effort. Shim thickness limit for any one stack is .750 of an inch.

Shims are available in .030", .060", and .120" thickness.

By adding a pack of shims .090" thick at both sides, camber will be decreased by approximately 1/2 degree.

By adding a .030" shim on one bolt and removing a .030" shim from the other, caster will change approximately 3/8 degree.

To help you determine the shim thickness change required to return caster and camber to design dimension, dimension change charts have been developed to enable you to do quicker and more accurate work. See Figures 3D-3, 3D-4, 3D-5 and 3D-6. The chart indicates the change required at (F) front and (R) rear shim position in order to return the initial reading to factory specifications. For example: Assume the initial readings for one B Series wheel were, camber plus 1/2° left side and 0° right side. Caster minus 1/4 degrees. Figure 3D-6 indicates that a subtraction of 0.18 shim thickness to the (F) front shim position and addition of plus .009 shim thickness to the (R) shim position would be required to adjust this wheel to factory specifications.

Torque control arm shaft nuts to specifications.

Torque wrench adapter J-22668 may be used if reading is calibrated for its use.

It is imperative that this torque specification be closely adhered to.

Checking Theoretical Kingpin (Steering Axis) Inclination

When checking theoretical king pin inclination, car must be on a level surface both transversely and fore and aft, must have trim heights within limits, and must be at curb load.

Set camber and caster to the desired specifications as shown. Measure king pin or steering axis inclination relative to a vertical plane. Add to the measured king pin axis angle the value of the positive camber angle (subtract if the camber is negative) and compare the resulting angle to the value given in the specification.

There is no adjustment for theoretical king pin inclination as this factor depends on the accuracy of the front suspension parts. Distorted steering knuckles should be replaced with new parts.

CAUTION: *Any heating, welding, or bending of front suspension parts to correct errors or repair damage must be avoided as this may pro-*

FOR CASTER AND CAMBER DIMENSIONS,
SEE WHEEL ALIGNMENT AND SPEC CHART.

FOR INCREASED OR POSITIVE CASTER, DECREASE
SHIMS AT BOLT "A" AND INCREASE SHIMS AT
BOLT "B" BY SAME AMOUNT

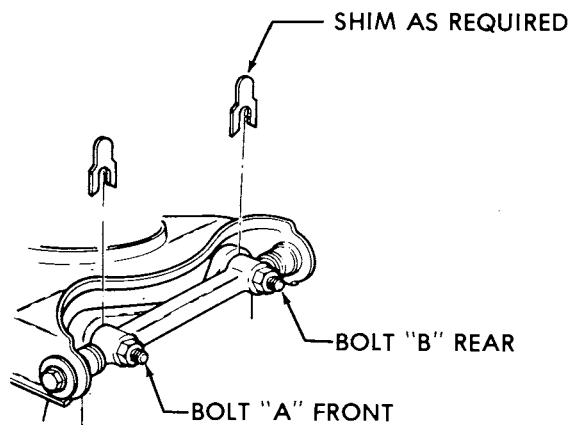

FOR DECREASED OR NEGATIVE CASTER,
INCREASE SHIMS AT BOLT "A" AND DE-
CREASE SHIMS AT BOLT "B" BY SAME
AMOUNT

FOR INCREASED CAMBER, DECREASE
SHIMS AT BOTH "A" AND "B" BOLTS.
SHIMMING GREATER THAN .750 NOT
PERMISSIBLE

SHIM THICKNESS AT "A" AND "B" LOCATION
TO BE WITHIN .40 OF EACH OTHER

4B3D1

Figure 3D-1 - X-A-B-C-E Series Shimming Location

*duce soft spots in the metal in which fatigue
and breakage may develop in service.*

Checking and Adjusting Toe-In

Toe-in is the distance in fractions of an inch that the front of the wheels are turned inward from a straight-ahead position.

Car must be at curb weight and front and rear suspension trim should be within specified limits. Bounce front end and allow it to settle to operating height. Steering gear and front wheel bearings must be properly adjusted with no looseness at tie rod ends. The car should be moved forward one complete revolution of the wheels before the toe-in check and adjustment are started and the car should never be moved backward while making the check and adjustment. This presets the front suspension and removes lash from the joints.

1. Turn steering wheel to straight-ahead position, with front wheels in same position.
2. Using a suitable toe-in gauge, measure the distance

between outside walls of tires at the front at a height approximately horizontal to floor and through the center-line of the wheel assembly. An accurate check also can be made by raising and rotating front wheels to scribe a fine line near the center of each tire, then, with tires on the floor and front end at running height, measure between scribed lines with a suitable trammel.

3. Roll the car forward until measuring points on tires are approximately 180 degrees from point used in Step 2 above.

The measurement at the front should be 1/16" less than the measurement at the rear.

4. If toe-in is not within specified limits, loosen clamp bolts and turn adjusting sleeves at tie rod ends as required. Left and right adjusting sleeves must be turned exactly the same amount but in opposite directions when changing toe-in, in order to maintain front wheels in straight-ahead position when steering wheel is in straight-ahead position.

Approximately the same amount of thread engagement in the adjuster sleeve should be noted for the inner and outer tie rod ends. The distance between the inner and outer tie rod ends in the adjuster sleeve should be approximately equal for both right and left wheels. The tie rods should never be lengthened to the point where the inner and outer threaded tie rod ends are outboard of the inner edge of the adjuster sleeve "U" clamps. If proper toe-in cannot be obtained within this amount of adjustment, inspect the suspension and steering linkage for bent parts.

5. After correct toe-in is secured, tighten clamp bolts securely.

The steering knuckle and steering arm "rock" or tilt as front wheel rises and falls. Therefore, it is of vital importance to center the travel of the inner tie rod joint by centering the tie rod stud in the socket (socket front face should be approximately vertical) and then position the bottom face of tie rod end parallel with machined surface at outer end of steering arm when tie rod length is adjusted. Severe damage and possible failure can result unless this precaution is observed. Tie rod clamp opening must not be over the sleeve opening. Refer to Steering Linkage Section for tie rod sleeve clamp position.

Checking Steering Geometry (Turning Angles)

Be sure that caster, camber, and toe-in have all been properly corrected before checking steering geometry. Steering geometry must be checked with the weight of the car on the wheels.

X-A-B-C-E Series

1. With the front wheels resting on full floating turntables, turn wheels to the right until the outside (left) wheel is set at 20 degrees. The inside (right) wheel should then be at the angle specified.
2. Repeat this test by turning front wheels to the left until the outside (right) wheel is at 20 degrees; the inside (left) wheel should then be at the angle specified.
3. Errors in steering geometry generally indicate bent steering arms, but may also be caused by other incorrect front end factors. If the error is caused by a bent steering

a steering arm or knuckle to correct steering geometry, since doing so may cause the part to break in service.

arm, the complete knuckle must be replaced. Replacement of such parts must be followed by a complete front end alignment check as described above. Never heat or bend

H Series

Be sure that caster, camber, and toe-in have all been prop-

FRONT END ALIGNMENT

Satisfactory vehicle operation may occur over a wide range of front end (wheel) alignment settings. Nevertheless, should settings vary beyond certain tolerances, readjustment of alignment is advisable. The specifications stated in Chart "A" of this manual should be used by owners, dealers, and repairmen as guidelines in vehicle diagnosis, either for repairs under the new vehicle warranty or for maintenance service at customers' requests. These specifications provide an acceptable all-around operating range in that they prevent abnormal tire wear caused by wheel alignment.

WHEEL ALIGNMENT SPECIFICATIONS

		CHART A Specifications for Diagnosis for Warranty Repairs Or Customer Paid Service	CHART B Specifications for Resetting Alignment
Caster	H Series X Series (Man/Strg.) X Series (P/Strg.) A Series B-C-E Series	-1 3/4° to +1/4° -2° to 0 0 to +2° +1° to +3° +1/2° to +2 1/2°	-1 1/4° to -1/4° -1 1/2° to -1/2° +1/2° to +1 1/2° +1 1/2° to +2 1/2° +1/2° to +2 1/2°
Camber	H Series	-3/4° to +1 1/4°	-1/4° to +3/4°
	X Series	0 to +1 1/2°	+1/4° to +1 1/4°
	A Series		
	R.H. Side L.H. Side	-1/4° to +1 1/4° +1/4° to +1 3/4°	0 to +1° +1/2° to +1 1/2°
	B-C-E Series		
	R.H. Side L.H. Side	-1/4° to +1 1/4° +1/4° to +1 3/4°	0 to +1° +1/2° to +1 1/2°
Toe In	H Series X-A-B-C-E Series	1/16" out to 3/16" in 1/16" ± 1/8"	0 to 1/8" in 0 to 1/8"
Cross Caster	All Series	No more than 1° side to side variation	No more than 1/2° side to side variation
Cross Camber	H Series	No more than 1° side to side variation	No more than 1/2° side to side variation
	X-A-B-C-E Series	Desirable - L.H. camber +1/2° more than R.H. camber limits - L.H. camber to +1 1/2° of R.H. camber	L.H. camber to be +1/4° to +3/4° of R.H. camber

Governmental Periodic Motor Vehicle Inspection programs usually include wheel alignment among items that are inspected. To provide useful information for such inspections, the tolerances shown in Chart "C" are applicable and well within the range of safe vehicle operation.

MOTOR VEHICLE INSPECTION STATION TOLERANCES

CHART C					
	H SERIES	X SERIES (MAN/STRG)	(P/STRG)	A SERIES	B-C-E SERIES
Caster	-2 3/4° to +1 1/4°	-3° to +1°	-1° to +3°	0 to +4°	-1/2° to +3 1/2°
Camber	-1 1/4° to +1 3/4°	-3/4° to +2 1/4°		R.H. +2° to -1°	R.H. +2° to -1°
				L.H. +2 1/2° to -1/2°	L.H. +2 1/2° to -1/2°
Toe-in	5/16" ± 7/16"	1/16" ± 3/8"		1/16" ± 3/8"	1/16" ± 3/8"

In the event the actual settings are beyond the specifications set forth in Chart "A" or "C" (whichever is applicable), or whenever for other reasons the alignment is being reset, Buick recommends that the specifications given in Chart "B" of the aforesaid applicable chart be used.

erly corrected before checking steering geometry. Steering geometry must be checked with the weight of the car on the wheels.

Measure the distance between the suspected bad arm and a stationary point on the brake backing plate or splash

shield, compare it with the same measurement on the other arm. The angle of the steering arms must be the same for both arms.

FRONT SUSPENSION ALIGNMENT CHART

X SERIES MANUAL STEERING
MEASURED CASTER READING

Manual Steering	+1-1/4°	+1°	+3/4°	+1/2°	+1/4°	0°	-1/4°	-1/2°	-3/4°	-1°	-1-1/4°	-1-1/2°	-1-3/4°	-2°	-2-1/4°	-2-1/2°	-2-3/4°	-3°	-3-1/4°	
BOLT																				
FRONT	+500	+411	+411	+410	+401	+401	+400	+311	+311	+310	+301	+301	+300	+300	+211	+210	+210	+210	+201	
REAR	+010	+011	+101	+110	+200	+201	+210	+300	+301	+310	+311	+400	+410	+411	+501	+600	+601	+611	+701	
FRONT	+410	+410	+401	+400	+311	+311	+310	+310	+301	+301	+300	+211	+211	+211	+210	+201	+201	+200	+111	
REAR	+001	+010	+011	+101	+110	+111	+201	+210	+300	+301	+310	+400	+401	+411	+501	+600	+601	+611	+110	
FRONT	+401	+400	+311	+311	+310	+301	+301	+211	+210	+211	+210	+210	+201	+201	+200	+111	+110	+110	+100	
REAR	-001	000	+011	+100	+110	+111	+201	+210	+300	+301	+310	+400	+410	+411	+500	+600	+601	+611	+100	
FRONT	+311	+311	+310	+301	+300	+300	+211	+211	+210	+201	+201	+200	+200	+111	+110	+101	+101	+100	+100	
REAR	-011	-001	000	+001	+100	+100	+101	+111	+200	+210	+211	+301	+310	+311	+401	+411	+500	+510	+600	
FRONT	+310	+301	+300	+300	+211	+210	+210	+201	+200	+200	+111	+111	+110	+110	+100	+100	+100	+011	+011	
REAR	-100	-011	-010	000	+001	+010	+100	+101	+111	+200	+210	+211	+301	+310	+401	+411	+500	+510	+600	
FRONT	+300	+211	+211	+210	+201	+201	+200	+200	+111	+110	+110	+101	+101	+100	+011	+010	+010	+001	+001	
REAR	-110	-101	-011	-010	000	+001	+100	+100	+101	+111	+200	+210	+211	+301	+310	+401	+411	+500	+500	
FRONT	+211	+210	+200	+201	+111	+111	+111	+110	+101	+101	+100	+100	+011	+010	+010	+001	+001	000	000	
REAR	-111	-110	-101	-011	-010	-001	+001	+100	+101	+110	+200	+210	+211	+300	+310	+401	+411	+500	+500	
FRONT	+201	+200	+200	+111	+110	+110	+101	+100	+100	+011	+010	+010	+001	+001	+001	+001	+001	+001	+001	
REAR	-201	-200	-110	-101	-100	-010	-001	000	+010	+011	+100	+110	+200	+201	+211	+300	+310	+400	+401	
FRONT	+111	+111	+110	+101	+100	+100	+011	+011	+010	+010	+001	+001	+001	+001	+001	+001	+001	+011	+011	
REAR	-211	-201	-200	-111	-101	-100	-011	-001	000	+010	+011	+101	+110	+200	+201	+211	+300	+310	+401	
FRONT	+110	+101	+100	+100	+011	+011	+010	+001	+001	000	000	000	+010	+010	+010	+010	+010	+010	+010	
REAR	-300	-211	-210	-200	-111	-110	-100	-011	-001	-001	-001	+010	+011	+101	+200	+201	+211	+300	+310	
FRONT	+100	+100	+011	+010	+010	+001	000	000	000	-001	-001	-001	-010	-010	-010	-010	-010	-010	-010	
REAR	-310	-301	-211	-210	-201	-111	-110	-100	-011	-001	-001	-001	-010	-010	-010	-010	-010	-010	-010	
FRONT	+011	+010	+001	+001	000	000	-001	-001	-001	-001	-001	000	+001	+001	+001	+001	+001	+001	+001	
REAR	-311	-310	-301	-211	-210	-201	-111	-110	-100	-011	-001	-001	-010	-010	-010	-010	-010	-010	-010	
FRONT	+001	+001	000	-001	-010	-010	-011	-110	-110	-101	-010	-010	-010	-001	-001	-001	-001	-001	-001	
REAR	-401	-400	-310	-301	-210	-210	-201	-111	-100	-010	-010	-010	-010	-001	-001	-001	-001	-001	-001	
FRONT	000	-001	-010	-010	-011	-100	-100	-101	-101	-101	-110	-110	-110	-001	-001	-001	-001	-001	-001	
REAR	-411	-401	-400	-311	-301	-210	-211	-201	-110	-100	-010	-010	-010	-001	-001	-001	-001	-001	-001	
FRONT	-010	-010	-011	-100	-101	-101	-110	-110	-110	-110	-200	-201	-201	-210	-210	-210	-210	-210	-210	
REAR	-500	-411	-410	-400	-311	-310	-300	-211	-201	-200	-110	-101	-100	-010	-001	-001	-001	-001	-001	
FRONT	-011	-100	-101	-101	-111	-111	-111	-200	-201	-201	-210	-210	-211	-211	-210	-200	-200	-210	-210	
REAR	-510	-501	-411	-410	-401	-311	-310	-300	-211	-210	-200	-111	-101	-100	-010	-001	-001	-001	-001	
FRONT	-101	-110	-110	-111	-200	-200	-201	-210	-210	-211	-211	-211	-300	-301	-310	-310	-310	-310	-400	
REAR	-511	-510	-411	-410	-401	-311	-310	-310	-310	-310	-210	-200	-200	-110	-100	-010	-001	-001	-001	
FRONT	-110	-111	-200	-201	-210	-210	-210	-211	-300	-300	-301	-301	-310	-310	-310	-400	-401	-401	-401	
REAR	-601	-600	-510	-501	-410	-401	-400	-310	-300	-300	-301	-310	-310	-310	-400	-400	-401	-401	-401	
FRONT	-200	-201	-210	-211	-211	-211	-211	-300	-300	-301	-310	-310	-311	-311	-400	-401	-401	-410	-410	
REAR	-611	-601	-600	-511	-501	-411	-401	-300	-300	-301	-310	-310	-311	-311	-400	-401	-410	-410	-410	

563D3

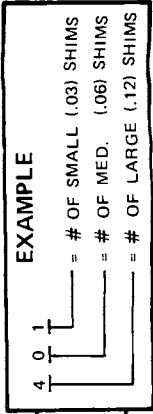

FRONT = SHIM REQUIRED AT FRONT BOLT
REAR = SHIM REQUIRED AT REAR BOLT

Figure 3D-3 - X Series Manual Steering Alignment Shim Chart

SPECIFICATIONS

FRONT END ALIGNMENT SPECIFICATION CHARTS

FRONT SUSPENSION ALIGNMENT CHART

X SERIES POWER STEERING
MEASURED CASTER READING

Power Steering	MEASURED CAMBER READING																			
	+3-1/4°	+3°	+2-3/4°	+2-1/2°	+2-1/4°	+2°	+1-3/4°	+1-1/2°	+1-1/4°	+1°	+3/4°	+1/2°	+1/4°	0°	-1/4°	-1/2°	-3/4°	-1°	-1-1/4°	
BOLT																				
FRONT	+410	+401	+400	+400	+400	+400	+311	+311	+311	+310	+310	+301	+301	+301	+300	+300	+300	+300	+300	+211
REAR	+110	+111	+200	+201	+210	+211	+300	+301	+301	+310	+311	+400	+401	+411	+500	+501	+510	+511	+600	+600
FRONT	+400	+400	+311	+311	+310	+310	+301	+301	+301	+300	+300	+300	+300	+211	+211	+211	+210	+210	+210	+210
REAR	+101	+101	+110	+111	+200	+201	+210	+211	+211	+210	+210	+210	+210	+210	+210	+210	+210	+210	+210	+210
FRONT	+311	+310	+310	+301	+301	+301	+300	+300	+211	+211	+211	+210	+210	+210	+210	+210	+210	+210	+210	+210
REAR	+011	+100	+101	+110	+111	+111	+200	+201	+210	+211	+211	+301	+301	+311	+400	+401	+410	+500	+501	+511
FRONT	+301	+301	+300	+300	+211	+211	+211	+210	+210	+210	+210	+210	+210	+210	+210	+210	+210	+210	+210	+210
REAR	+001	+010	+011	+100	+101	+110	+110	+110	+110	+110	+110	+110	+110	+110	+110	+110	+110	+110	+110	+110
FRONT	+300	+211	+211	+210	+210	+210	+201	+201	+201	+200	+200	+200	+200	+200	+200	+200	+200	+200	+200	+200
REAR	+000	+001	+010	+010	+011	+010	+101	+110	+111	+110	+110	+110	+110	+110	+110	+110	+110	+110	+110	+110
FRONT	+210	+210	+201	+201	+200	+200	+111	+111	+111	+110	+110	+100	+100	+100	+100	+100	+100	+100	+100	+100
REAR	-010	-001	000	+001	+010	+011	+100	+101	+101	+101	+101	+100	+100	+100	+100	+100	+100	+100	+100	+100
FRONT	+200	+200	+200	+111	+111	+110	+110	+110	+101	+101	+100	+100	+100	+100	+100	+100	+100	+100	+100	+100
REAR	-011	-011	-010	-001	000	+001	+101	+101	+101	+101	+101	+101	+101	+101	+101	+101	+101	+101	+101	+101
FRONT	+111	+110	+110	+110	+101	+101	+100	+100	+100	+100	+100	+100	+100	+100	+100	+100	+100	+100	+100	+100
REAR	-101	-101	-100	-011	-010	-001	-001	-001	-001	-001	-001	-001	-001	-001	-001	-001	-001	-001	-001	-001
FRONT	+101	+101	+101	+100	+100	+100	+010	+010	+010	+010	+010	+010	+010	+010	+010	+010	+010	+010	+010	+010
REAR	-111	-110	-101	-100	-101	-101	-001	-001	-001	-001	-001	-001	-001	-001	-001	-001	-001	-001	-001	-001
FRONT	+100	+011	+011	+011	+010	+010	000	000	000	000	000	000	000	000	000	000	000	000	000	000
REAR	-200	-111	-110	-110	-101	-100	-011	-010	-010	-001	-001	-001	-001	-001	-001	-001	-001	-001	-001	-001
FRONT	+010	+010	+001	+001	+001	+001	-001	-001	-001	-001	-001	-001	-001	-001	-001	-001	-001	-001	-001	-001
REAR	-210	-201	-200	-111	-110	-101	-100	-011	-010	-010	-001	-001	-001	-001	-001	-001	-001	-001	-001	-001
FRONT	+001	000	000	000	000	000	-001	-001	-001	-001	-001	-001	-001	-001	-001	-001	-001	-001	-001	-001
REAR	-211	-210	-210	-200	-111	-110	-101	-101	-101	-101	-101	-100	-100	-100	-100	-100	-100	-100	-100	-100
FRONT	+010	-001	-010	-010	-011	-011	-100	-101	-101	-101	-101	-101	-101	-101	-101	-101	-101	-101	-101	-101
REAR	-301	-300	-211	-210	-201	-200	-111	-110	-110	-110	-110	-110	-110	-110	-110	-110	-110	-110	-110	-110
FRONT	-010	-010	-011	-010	-011	-011	-101	-101	-101	-101	-101	-101	-101	-101	-101	-101	-101	-101	-101	-101
REAR	-311	-310	-301	-300	-211	-210	-110	-110	-110	-110	-110	-110	-110	-110	-110	-110	-110	-110	-110	-110
FRONT	-100	-100	-101	-101	-110	-110	-200	-201	-201	-200	-200	-200	-200	-200	-200	-200	-200	-200	-200	-200
REAR	-400	-311	-310	-301	-300	-300	-211	-210	-210	-210	-210	-210	-210	-210	-210	-210	-210	-210	-210	-210
FRONT	-101	-110	-110	-111	-111	-111	-200	-200	-201	-201	-201	-210	-210	-210	-211	-211	-211	-211	-211	-211
REAR	-410	-401	-400	-311	-310	-301	-300	-211	-210	-210	-210	-210	-210	-210	-210	-210	-210	-210	-210	-210
FRONT	-111	-111	-200	-200	-201	-201	-210	-210	-210	-210	-210	-210	-210	-210	-210	-210	-210	-210	-210	-210
REAR	-411	-410	-410	-400	-311	-310	-301	-300	-211	-210	-210	-210	-210	-210	-210	-210	-210	-210	-210	-210
FRONT	-201	-201	-210	-210	-210	-211	-211	-211	-211	-211	-211	-211	-211	-211	-211	-211	-211	-211	-211	-211
REAR	-501	-500	-411	-410	-401	-400	-311	-310	-301	-300	-300	-300	-300	-300	-300	-300	-300	-300	-300	-300
FRONT	-210	-211	-211	-211	-211	-211	-211	-211	-211	-211	-211	-211	-211	-211	-211	-211	-211	-211	-211	-211
REAR	-510	-510	-501	-500	-411	-410	-311	-310	-301	-300	-300	-300	-300	-300	-300	-300	-300	-300	-300	-300

583D4

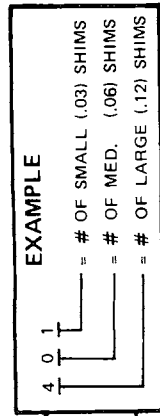

FRONT = SHIM REQUIRED AT FRONT BOLT
 REAR = SHIM REQUIRED AT REAR BOLT

Figure 3D-4 - X Series Power Steering Alignment Shim Chart

FRONT SUSPENSION ALIGNMENT CHART

MEASURED CASTER READING

B-C-E SERIES

Left	Right	BOLT	+3-1/2°	+3-1/4°	+3°	+2-3/4°	+2-1/2°	+2-1/4°	+2°	+1-3/4°	+1-1/2°	+1-1/4°	1°	+3/4°	+1/2°	+1/4°	0°	-1/4°	-1/2°	-3/4°	
			+3-1/4°	+2-3/4°	FRONT	+411	+410	+410	+401	+400	+400	+400	+311	+310	+310	+310	+301	+301	+300	+300	+211
+3°	+2-1/2°	REAR	+200	+201	+201	+210	+210	+210	+210	+310	+310	+310	+310	+300	+300	+300	+300	+210	+210	+210	+210
+2-3/4°	+2-1/4°	FRONT	+401	+400	+400	+400	+311	+311	+311	+201	+201	+201	+201	+211	+211	+211	+211	+210	+210	+210	+210
+2-1/2°	+2°	REAR	+110	+111	+111	+200	+201	+201	+201	+300	+300	+300	+300	+310	+310	+310	+310	+200	+200	+200	+200
+2-1/4°	+1-3/4°	FRONT	+400	+311	+311	+310	+300	+211	+211	+210	+210	+210	+210	+200	+200	+200	+200	+111	+111	+111	+111
+2°	+1-1/2°	REAR	+101	+110	+110	+110	+110	+110	+110	+201	+201	+201	+201	+211	+211	+211	+211	+110	+110	+110	+110
+1-3/4°	+1-1/4°	FRONT	+310	+310	+310	+300	+211	+211	+211	+210	+210	+210	+210	+200	+200	+200	+200	+111	+111	+111	+111
+1-1/2°	+1°	REAR	+011	+100	+100	+101	+110	+110	+110	+201	+201	+201	+201	+211	+211	+211	+211	+110	+110	+110	+110
+1-1/4°	+3/4°	FRONT	+301	+300	+300	+211	+210	+210	+210	+110	+110	+110	+110	+101	+101	+101	+101	+010	+010	+010	+010
+1°	+3/4°	REAR	+001	+010	+010	+100	+101	+101	+101	+110	+110	+110	+110	+101	+101	+101	+101	+010	+010	+010	+010
+3/4°	+1/2°	FRONT	+211	+210	+210	+201	+200	+200	+200	+111	+111	+111	+111	+101	+101	+101	+101	+010	+010	+010	+010
+1/2°	0°	REAR	+000	+001	+001	+100	+100	+100	+100	+110	+110	+110	+110	+101	+101	+101	+101	+010	+010	+010	+010
+1/4°	-1/4°	FRONT	+201	+201	+201	+110	+110	+110	+110	+100	+100	+100	+100	+010	+010	+010	+010	+000	+000	+000	+000
0°	-1/2°	REAR	+010	+110	+110	+110	+110	+110	+110	+100	+100	+100	+100	+010	+010	+010	+010	+000	+000	+000	+000
-1/4°	-1/4°	FRONT	+110	+110	+110	+110	+110	+110	+110	+100	+100	+100	+100	+010	+010	+010	+010	+000	+000	+000	+000
-1/2°	-3/4°	REAR	+010	+100	+100	+100	+100	+100	+100	+110	+110	+110	+110	+101	+101	+101	+101	+010	+010	+010	+010
-1/4°	-1/2°	FRONT	-010	-010	-010	-100	-100	-100	-100	-110	-110	-110	-110	-101	-101	-101	-101	-010	-010	-010	-010
-1°	-1/4°	REAR	-301	-310	-310	-300	-211	-210	-210	-210	-210	-210	-210	-201	-201	-201	-201	-110	-110	-110	-110
-1-1/4°	-1-1/2°	FRONT	-101	-110	-110	-110	-110	-110	-110	-101	-101	-101	-101	-010	-010	-010	-010	-000	-000	-000	-000
-1-1/2°	-1-3/4°	REAR	-400	-311	-310	-310	-300	-211	-210	-210	-210	-210	-210	-201	-201	-201	-201	-110	-110	-110	-110
-1-1/4°	-1°	FRONT	-110	-111	-111	-110	-110	-110	-110	-101	-101	-101	-101	-010	-010	-010	-010	-000	-000	-000	-000
-1°	-1-1/2°	REAR	-401	-401	-401	-310	-310	-310	-310	-210	-210	-210	-210	-201	-201	-201	-201	-110	-110	-110	-110
-1-1/2°	-1-1/4°	FRONT	-200	-200	-200	-201	-210	-210	-210	-210	-210	-210	-210	-201	-201	-201	-201	-110	-110	-110	-110
-1-3/4°	-1°	REAR	-411	-410	-401	-401	-310	-310	-310	-210	-210	-210	-210	-201	-201	-201	-201	-110	-110	-110	-110
-1-1/4°	-1-1/2°	FRONT	-201	-210	-210	-210	-210	-210	-210	-201	-201	-201	-201	-110	-110	-110	-110	-000	-000	-000	-000
-1-1/2°	-1-1/4°	REAR	-501	-500	-411	-410	-401	-401	-401	-310	-310	-310	-310	-210	-210	-210	-210	-110	-110	-110	-110

5B3D6

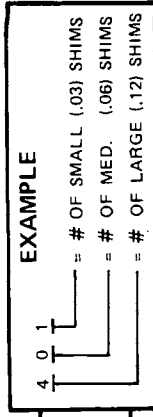

FRONT = SHIM REQUIRED AT FRONT BOLT
REAR = SHIM REQUIRED AT REAR BOLT

MEASURED CAMBER READING

Figure 3D-6 - B-C-E Series Alignment Shim Chart

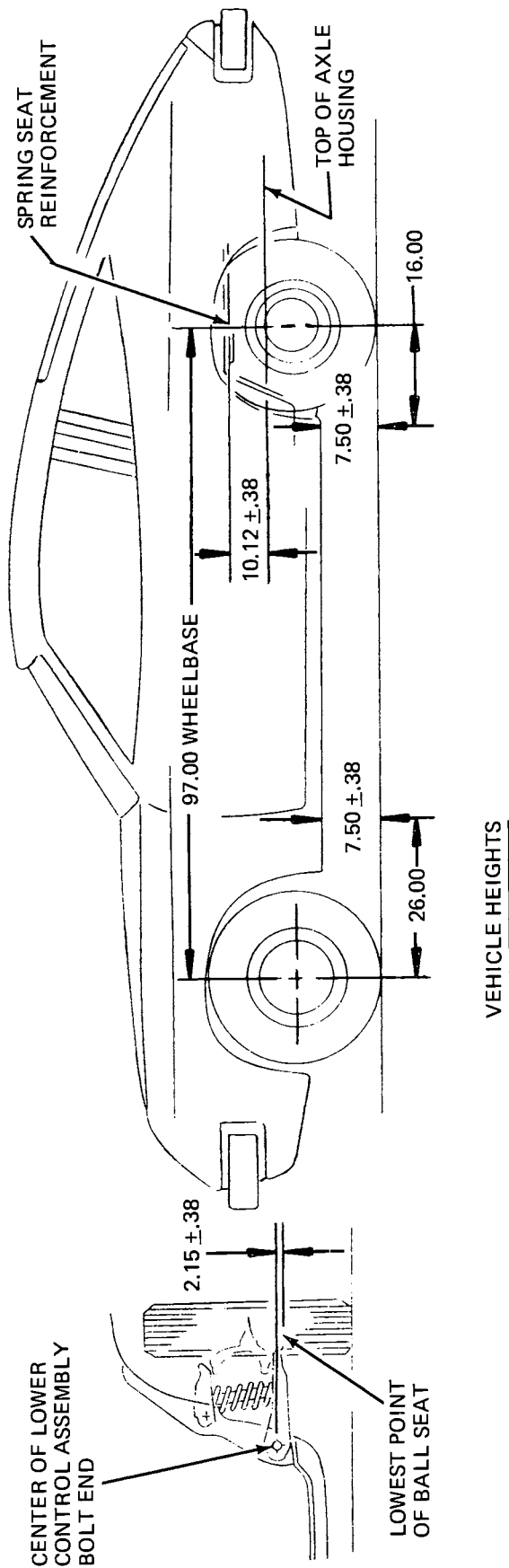

"Z" & "J" DIMENSIONS-LIFT FRONT BUMPER OF VEHICLE UP APPROXIMATELY 1.50 GENTLY REMOVE HANDS AND LET VEHICLE SETTLE. REPEAT TWICE FOR A TOTAL OF 3 TIMES. MEASURE "Z" AND "J" DIMENSIONS. PUSH FRONT BUMPER DOWN APPROXIMATELY 1.50, GENTLY REMOVE HANDS AND LET VEHICLE RISE ON ITS OWN. REPEAT TWICE FOR A TOTAL OF 3 TIMES. MEASURE "Z" & "J" DIMENSIONS. TRUE HEIGHTS ARE THE AVERAGE OF THE HIGH & LOW MEASUREMENTS.

RECOMMENDED TIRE PRESSURE

SET PRESSURE TO AGREE WITH VEHICLE TIRE PRESSURE STICKER FOR LOADING "UP TO VEHICLE CAPACITY".

"D" & "K" DIMENSIONS-LIFT REAR BUMPER OF VEHICLE UP APPROXIMATELY 1.50. GENTLY REMOVE HANDS & LET VEHICLE SETTLE ON ITS OWN. REPEAT TWICE FOR A TOTAL OF 3 TIMES. MEASURE "D" & "K" DIMENSIONS. PUSH REAR BUMPER OF VEHICLE DOWN APPROXIMATELY 1.50. GENTLY REMOVE HANDS AND LET VEHICLE RISE ON ITS OWN. REPEAT TWICE FOR A TOTAL OF 3 TIMES. MEASURE "D" & "K" DIMENSIONS. TRUE HEIGHTS ARE THE AVERAGE OF THE HIGH & LOW MEASUREMENTS.

LOAD CONDITIONS

CURB WEIGHT-COOLANT TO CAPACITY AND FULL TANK OF GASOLINE.

5B3D7

Figure 3D-7 - H Series Trim Height

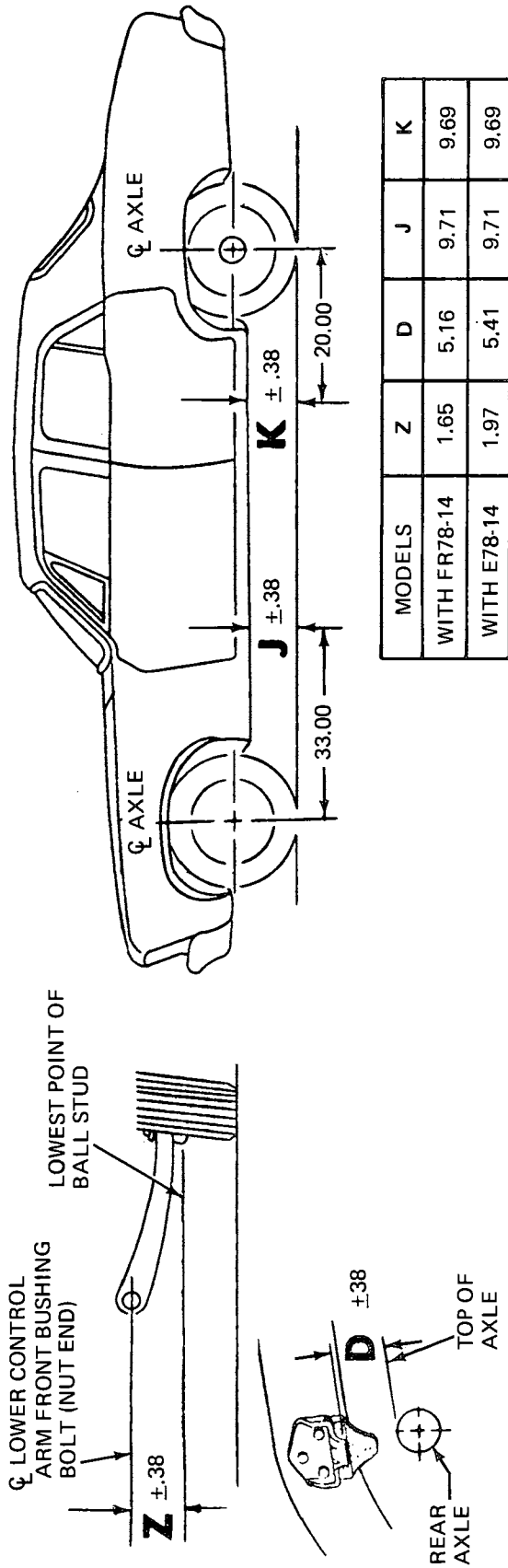

VEHICLE HEIGHTS

"Z" & "J" DIMENSIONS-LIFT FRONT BUMPER OF VEHICLE UP APPROXIMATELY 1.50 GENTLY REMOVE HANDS AND LET VEHICLE SETTLE; REPEAT TWICE FOR A TOTAL OF 3 TIMES. MEASURE "Z" AND "J" DIMENSIONS. PUSH FRONT BUMPER DOWN APPROXIMATELY 1.50. GENTLY REMOVE HANDS AND LET VEHICLE RISE ON ITS OWN. REPEAT TWICE FOR A TOTAL OF 3 TIMES. MEASURE "Z" & "J" DIMENSIONS.

TRUE HEIGHTS ARE THE AVERAGE OF THE HIGH & LOW MEASUREMENTS.

RECOMMENDED TIRE PRESSURE

TRIM HEIGHT AND AUDIT CHECK- SET PRESSURE TO AGREE WITH VEHICLE TIRE PRESSURE STICKER FOR LOADING "UP TO VEHICLE CAPACITY".

DIMENSIONS "Z", "J" & "K" VERTICAL TO GROUND

"D" & "K" DIMENSIONS-LIFT REAR BUMPER OF VEHICLE UP APPROXIMATELY 1.50. GENTLY REMOVE HANDS & LET VEHICLE SETTLE ON ITS OWN. REPEAT TWICE FOR A TOTAL OF 3 TIMES. MEASURE "D" & "K" DIMENSIONS. PUSH REAR BUMPER OF VEHICLE DOWN APPROXIMATELY 1.50. GENTLY REMOVE HANDS AND LET VEHICLE RISE ON ITS OWN. REPEAT TWICE FOR A TOTAL OF 3 TIMES. MEASURE "D" & "K" DIMENSIONS.

TRUE HEIGHTS ARE THE AVERAGE OF THE HIGH & LOW MEASUREMENTS.

LOAD CONDITIONS

CURB WEIGHT-VEHICLE INCLUDES COOLANT TO CAPACITY AND FULL TANK OF GASOLINE.

Figure 3D-8 - X Series Trim Height

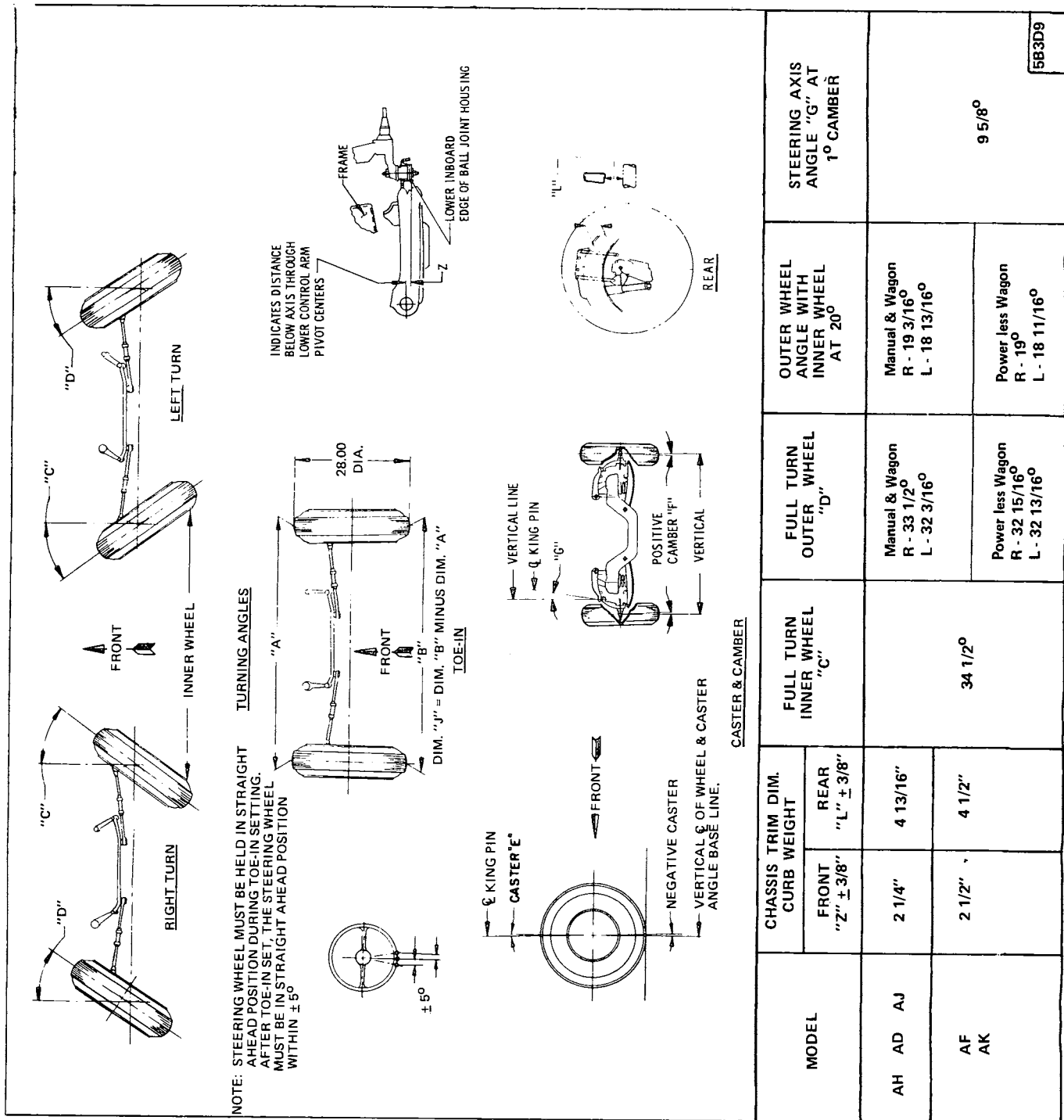

Figure 3D-9 - A Series Trim Height

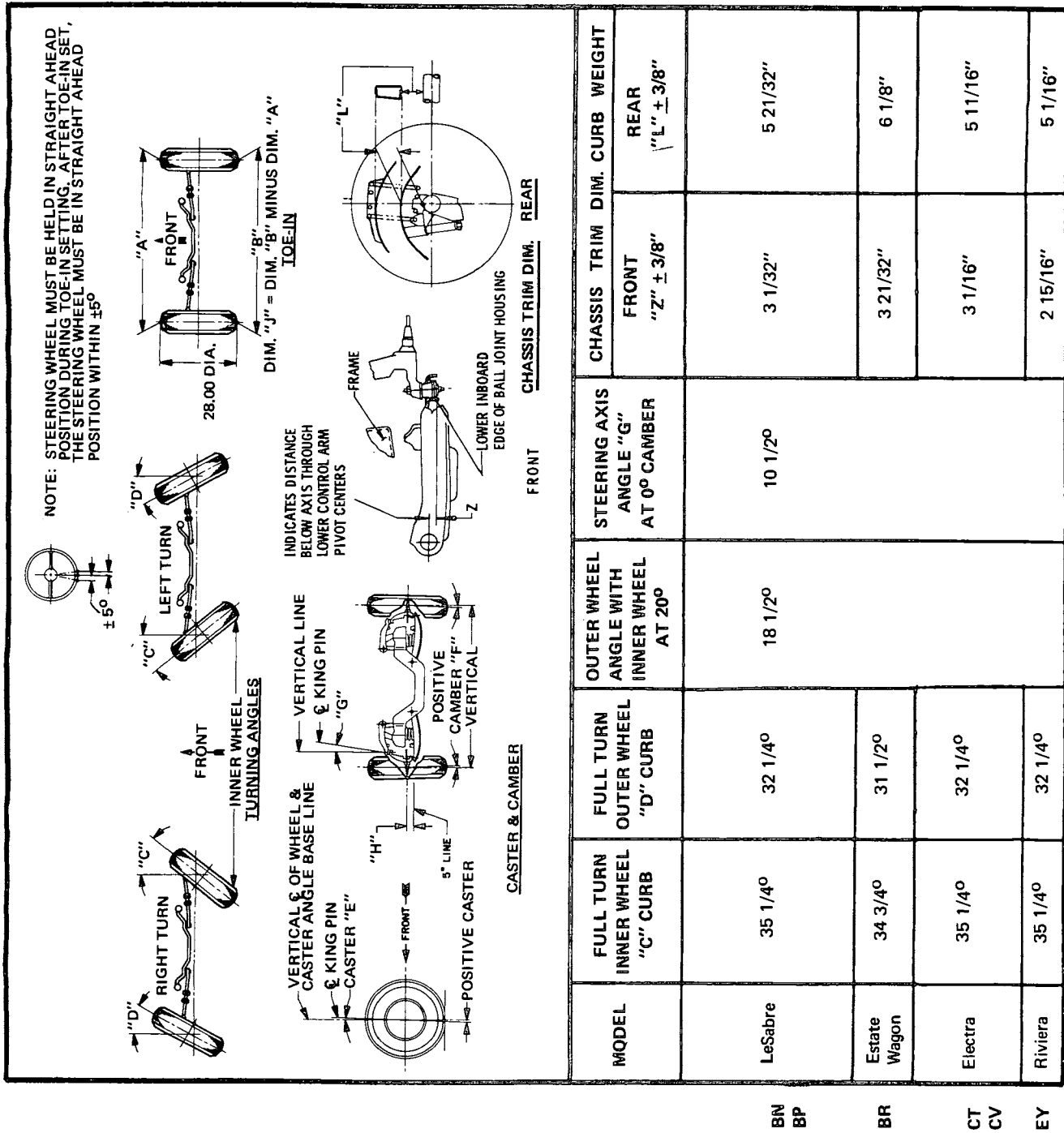

Figure 3D-10 - B-C-E Series Trim Height