

# FRONT SUSPENSION

## CONTENTS

<b>DESCRIPTION AND OPERATION:</b>	
Suspension Description H Series .....	3B- 1
Suspension Description X-A-B-C-E Series.....	3B- 1
<b>DIAGNOSIS:</b>	
Faulty Springs, Shock Absorbers and Ball Joints .....	3B- 2
<b>MAINTENANCE AND ADJUSTMENTS:</b>	
Replacement and Adjustment of Front Wheel Bearings.....	3B- 5
<b>MAJOR REPAIR:</b>	
Removal and Installation of Ball Joints and Steering Knuckle .....	3B- 7
Removal and Installation of Upper Control Arm Assembly .....	3B- 9
Removal and Installation of Lower Control Arm Assembly .....	3B-10
Removal and Installation of Upper Control Arm Bushings.....	3B-10
Removal and Installation of Lower Control Arm Bushings.....	3B-12
Removal and Installation of Front Springs .....	3B-13
Removal and Installation of Shock Absorbers .....	3B-14
Removal and Installation of Stabilizer Bar .....	3B-14
<b>SPECIFICATIONS:</b>	
Bolt Torque Specifications .....	3B-15
Dimensional Specifications .....	3B-15

## DESCRIPTION AND OPERATION

### SUSPENSION DESCRIPTION H SERIES

The H Series front suspension is of the A frame type with short and long control arms. The upper control arm is bolted to the front end sheet metal at each inner pivot point. Rubber bushings are used for mounting.

The lower control arm attaches to the front end sheet metal, with two cam type bolts, through rubber bushings. The front cam bolts adjust camber and the rear cam bolts adjust caster. See Figure 3B-18.

The upper ball joint is riveted to the upper control arm and the lower ball joint is pressed into the lower control arm.

The coil springs are mounted between the lower control arms and the shock absorber tower. The lower control arm and the shock absorber tower have helical spring seats which makes spring indexing easy since there is a stop on both seats.

Shock absorbers mount to the lower control arm and run through the center of the coil spring to the shock absorber tower where the upper stem mounts.

The steering knuckle and steering arm are one piece. The wheel hub is an integral part of the brake disc and mounts to the wheel spindle in the conventional manner with inner and outer wheel bearings. See Figure 3B-19.

### SUSPENSION DESCRIPTION X-A-B-C-E SERIES

The front suspension is designed to allow each wheel to compensate for changes in the road surface level without affecting the opposite wheel. Each wheel is independently connected to the frame by a steering knuckle, ball joint assemblies, and upper and lower control arms. The con-

trol arms are designed and positioned to allow the steering knuckles to move in a prescribed three dimensional arc. The front wheels are held in proper relationship to each other by two tie rods which are connected to steering arms on the knuckles and to an intermediate rod.

Coil chassis springs are mounted between the spring housings on the frame and the lower control arms. Ride control is provided by double, direct acting shock absorbers mounted inside the coil springs and attached to the lower control arm by bolts. The upper portion of each shock absorber extends through the frame bracket and is secured with two grommets, two grommet retainers, and a nut.

Side roll of the front suspension is controlled by a spring steel stabilizer shaft. It is mounted in rubber bushings which are held to the frame side rails by brackets. The ends of the stabilizer are connected to the lower control arms by means of links which are isolated by rubber grommets which provide flexibility and ride features.

A ball joint is riveted to the outer end of the upper arm. The upper control arm is attached to a cross shaft through rubber bushings. The cross shaft, in turn, is bolted to frame brackets. The ball joint is pre-loaded by a rubber spring to insure proper seating of the ball in the socket.

The inner ends of the lower control arms are bolted to the frame through rubber bushings. The outer end of each arm is connected to the steering knuckle with a ball joint assembly pressed in the lower control arm and bolted to the steering knuckle. Fore-aft alignment is maintained by the wide span lower control arm.

Rubber seals are part of the ball joint assemblies to keep dirt and moisture from entering the joint and damaging bearing surfaces.

Shock absorbers are direct double-acting type.

## DIAGNOSIS

### FAULTY SPRINGS, SHOCK ABSORBERS, AND BALL JOINTS

#### Trim Height Checking Considerations

Tire size, undercoating, accumulated dirt, etc., change the car weight and must be considered when checking spring trim dimensions. Buick springs are computer selected for the specific options and tire size of the car. The dimensions given are the nominal standard car at curb weight, and may normally vary to a certain extent.

Curb weight includes a full tank of gas, oil, water, and spare tire but no passengers.

Before measuring spring trim dimensions, bounce both ends of the car up and down several times to make sure there is no bind in suspension members, and to let springs take a natural position.

#### Measuring Trim Height

1. On a new car, the *front* spring trim dimension "Z" should be as shown in the Front Wheel Alignment Section. As mileage accumulates the trim height may be less due to normal settling of bushings, dirt accumulation, etc.
2. On a new car, the *rear* spring trim dimension "L" should be as shown in the Front Wheel Alignment Section. As mileage accumulates the trim height may be less due to normal settling of bushings, dirt accumulation, etc.
3. When checking *side to side* differences in trim height at the *front* take measurements at the front rocker panel as shown in the Rear Suspension Section.

A maximum of two (2) front shims may be installed on top of the front spring with a change in trim height double the thickness of the shims. This will provide for a maximum correction at the fender of .50 inch. A maximum of two (2) rear shims may be installed between the rear spring and the spring seat on the axle with a change in trim height the same as the thickness of the shims. This will provide for a maximum correction at the fender of .24 inch. Cars with 1 inch tilt right to left cannot be corrected by shims. If side to side variation is in excess of one inch, check suspension components for damage, excessive wear, or incorrect spring installation.

4. When checking side to side differences in trim height at the *rear* take measurements at the rear rocker panel as shown in the Rear Suspension Section.

Shimming of only one rear spring is not effective in correcting tilt. Side to side variation should be corrected by changing or shimming front springs.

#### Installation of Front Spring Shim X-A-B-C-E Series

1. Remove front spring from car as described in this section.
2. Place shim at top of spring as shown in Figure 3B-1. Taping shim to spring will aid installation.
3. Install shimmed spring in car as described in this section.

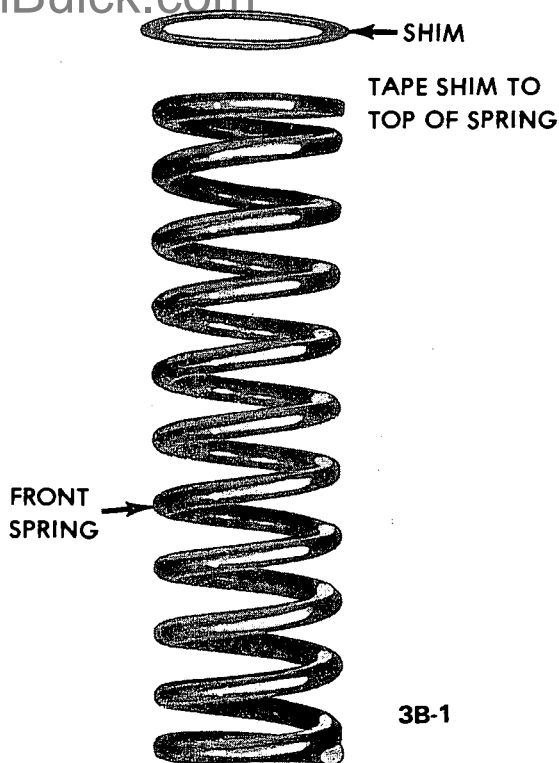

Figure 3B-1 - Installing Shim on Spring

#### Weak and Non-Operative Shock Absorbers

Many shock absorbers have been replaced and returned to the factory with the report that they were weak or leaking oil. When tested with special factory equipment very few of these replaced units have been found weak, leaking oil, or otherwise below standard in operation. This indicates that these shock absorbers were needlessly replaced in an attempt to improve riding conditions which were actually standard, or that incorrect methods were used in diagnosing the condition of the units.

Leaking shocks should not be diagnosed by observing a light oil film on or around the shock.

The shock absorber seal is designed to allow for lubrication of the piston rod, which under normal conditions, causes a light oil film to accumulate on the shock. This does not affect shock operation nor is replacement necessary as *all Delco shocks contain an added fluid reserve for this purpose.*

A leaking shock absorber is easily spotted as there will be evidence of fluid droplets on or around the shock. Before replacing any shock absorber, verify that the oil present on the shocks is not from some other chassis component.

Before attempting to test shock absorbers make sure that all attaching bolts and nuts are tight. Tires should be uniformly inflated to specified pressure. The chassis should be well lubricated to make sure that suspension parts are free moving.

Test each front and rear shock absorber in turn by quickly pushing down and then lifting up on the end of the car bumper closest to the unit being checked. Use the same amount of force on each test, and note the amount of resistance provided by the shock absorber on compression and rebound. A little practice on another car of the same

model which has satisfactory ride control will aid in judging the amount of resistance that should exist. Both front shock absorbers should provide the same feeling of resistance as should the rear shock absorbers. Any noticeable variation between right and left shock absorbers indicates that one unit is not operating normally. Little or no resistance on compression or rebound indicates air in the shock absorbers, internal leakage due to wear, or that the valve is held open by dirt. Excessive resistance indicates that the bleeder holes in the valve are plugged with dirt.

If there is any doubt about the action of a shock absorber after testing as described above, remove the unit from car. Mount it vertically in a vise with the jaws gripping the lower mounting firmly, then move the piston rod up and down by hand. There should be no free movement in this test. Lack of resistance or jerky resistance to movement indicates air in the shock absorber, internal leakage due to wear, or that the valve is held open by dirt. A faulty shock absorber must be replaced as it cannot be disassembled for repairs. In the test given above, the amount of force that can be applied is not sufficient to open a valve against its spring pressure; therefore, this test only checks the flow of fluid through the valve bleeder hole or due to internal wear of piston and cylinder. Since it is unlikely that the valve springs will weaken in service, it may be assumed that the shock absorber action is normal, if it operates satisfactorily in the test given above.

**Loose Ball Joints**

The upper ball joint stud on all series Buicks is rubber

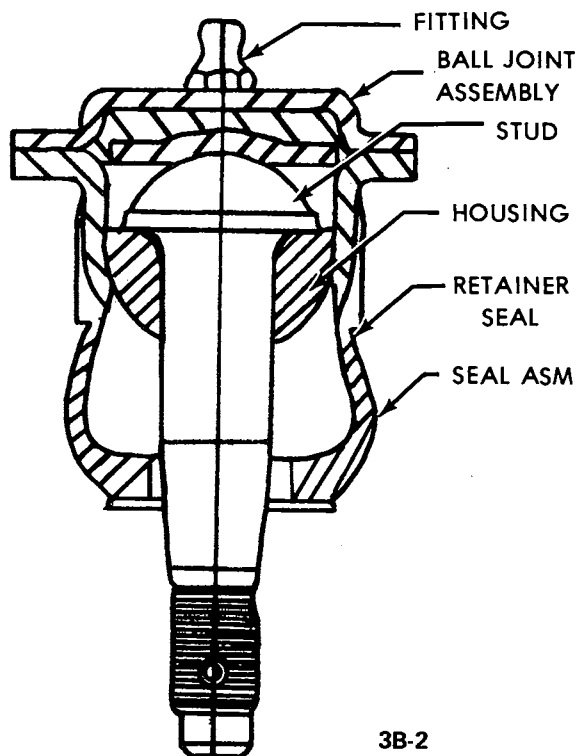

3B-2

Figure 3B-2 All Series - Upper Ball Joint

**VISUAL WEAR INDICATING LOWER BALL JOINT**

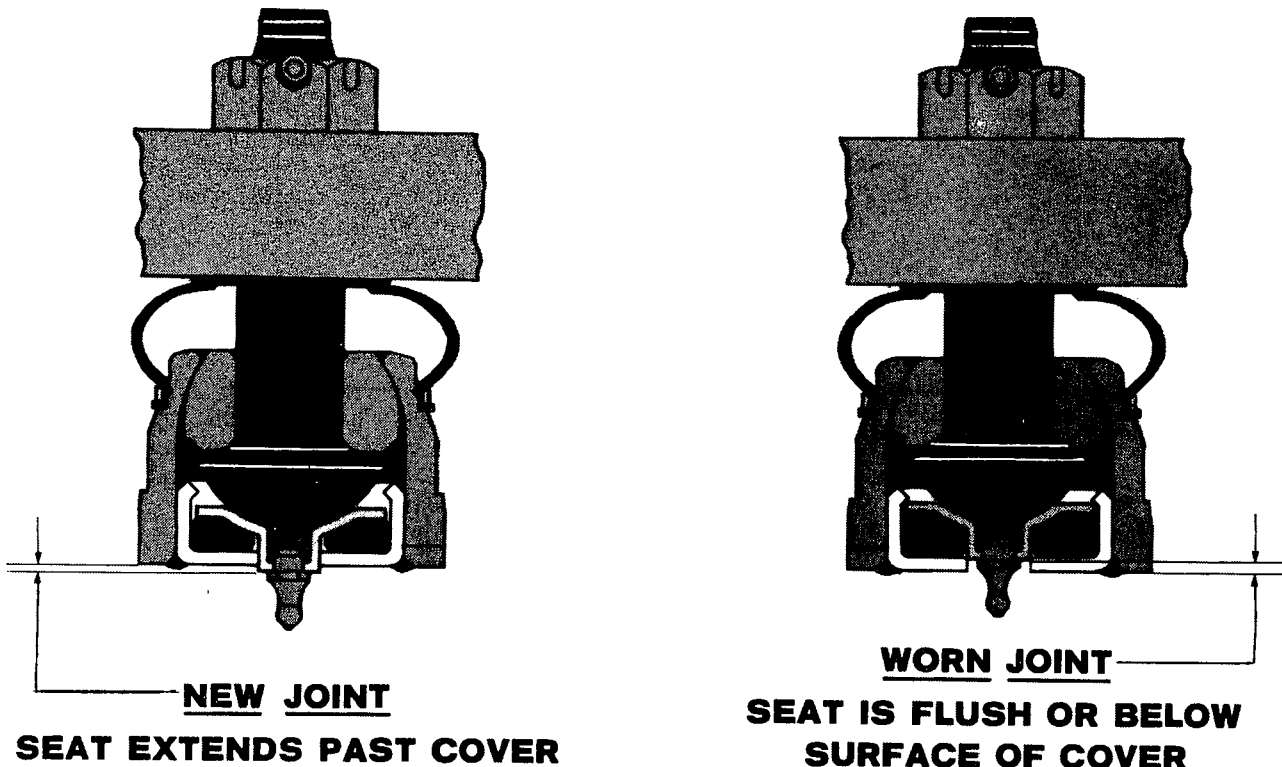

3B-4

Figure 3B-3 All Series Lower Ball Joint

spring equipped and thus preloaded in its socket at all times. See Figure 3B-2. This minimizes looseness at the socket and compensates for normal wear. If the upper stud has any noticeable lateral shake, or if it can be twisted in its socket with the fingers, the upper ball joint should be replaced. This check is done with the ball joint disconnected from the steering knuckle.

A torque check can also be run on the upper ball joint. The torque check is as follows:

1. Remove the ball joint stud from the steering knuckle and replace the stud nut.
2. Check to see if any torque is required to rotate the ball stud in the socket.
3. If no torque is required, and the joint is properly lubricated, replace the ball joint.

Sometimes a malfunctioning ball joint can be detected by simply applying horizontal pressure on the tire and wheel assembly and watching the suspected ball joint. If the ball joint shows any motion other than the normal rotational

and rocking motion, it's possible that the ball joint is malfunctioning and further diagnosis should be pursued as described.

On all Series Buicks, the lower ball joint is inspected for wear by visual observation. See Figure 3B-3. Wear indicated by the protrusion of the 1/2 inch diameter nipple into which the grease fitting is threaded. This round nipple projects 1/16 inch beyond the surface of the ball joint cover on a new, unworn joint. Normal wear will result in the surface of the nipple retreating very slowly inward.

To inspect for wear, raise the vehicle on a hoist. The vehicle must be supported by its wheels or frame so the lower ball joint is in a loaded condition. Wipe grease fitting and nipple clean and observe the nipple's position relative to the surface of the ball joint. If the round nipple is flush or inside the cover surface, replace the ball joint.

If loose upper control arm bushing retaining nuts are encountered, it might be necessary to remove the upper control arm to torque the bolts. Bolts should be tightened with the car at curb height. It may be necessary to use Torque Wrench Adapter J-22618. Torque to specification.

Condition	Test Inspection Procedure
Incorrect, weak or inoperative shock absorber	Visual inspection for oil - slight seepage is normal - could be oil spray from another source - replace if the shock is leaking excessively. Test each front shock absorber in turn by quickly pushing down and then lifting up on the end of the bumper closest to the unit being checked. Use the same amount of force on each test and note the amount of resistance provided by the shock absorber on compression and rebound. For additional information, refer to Testing and Inspection of Shock Absorbers - this section.
Incorrect, weak or unmatched springs	Check trim height measurements with specifications. Either replace the spring with the correct unit or shim to desired height. For additional information, refer to Measuring Trim Height and Installing Front Spring Shims - this section.
Stabilizer bar loose	Visually inspect assembly and correct as necessary - torque to specifications.
Incorrect Front Wheel Bearing Adjustment	Feel for bearing looseness while supporting car on the frame to allow the suspension to hang freely in an extension condition. Shake the wheel and tire assembly with a vertical grasp to isolate bearing feel from ball joint and linkage feel (.001 - .005 inch end play). If the bearings need readjusting, use the following procedure: <ol style="list-style-type: none"> <li>1. Snug the spindle nut while turning the disc assembly forward to fully seat the bearing.</li> <li>2. Back off the nut 1/4 to 1/2 of a turn to the just loose position.</li> <li>3. Hand tighten the nut, but do not insert the cotter pin.</li> </ol>

Condition	Test Inspection Procedure
Worn Front Wheel Bearings	<p>4. BACK OFF THE NUT A MINIMUM OF 1/12 of a turn and a maximum of 1/6 of a turn to a cotter pin hole and insert the cotter pin. UNDER NO CIRCUMSTANCES is the nut to be even finger tight. For additional information refer to Replacement and Adjustment of Front Wheel Bearings in this section.</p>
Worn or Insufficiently Lubricated Ball Joints or Control Arm Bushings	<p>Listen for a grinding or a rough noise from bearing area - feel for a roughness while rotating the wheel and tire assembly. A more accurate check can be made with the bearing and hub assembly disassembled. Bearing appearance usually does not dictate the operating condition. Bearings should be replaced only if they operate roughly or produce abnormal noises. For additional information, refer to Wheel Bearing Service - this section.</p>
Loose Shock Absorber Mounting	<p>Check for proper ball joint operation by the appropriate means as outlined in this section under Checking for Loose Ball Joints. If the ball joint is to be replaced, reference should be made to the ball joint service portion of the Major Repairs Section. Visual observation of the bushings while shaking the control arm can isolate a worn bushing. If play exists, the bushing should be replaced (if the end nuts are not welded to the shaft) as outlined in the bushing service portion of the Major Repairs Section.</p>
Loose Shock Absorber Mounting	<p>Visual observation of the shock mounts will indicate whether the shock is properly mounted or not. If the shock is reinstalled, torque to specifications.</p>

## MAINTENANCE AND ADJUSTMENTS

### REPLACEMENT AND ADJUSTMENT OF FRONT WHEEL BEARINGS

#### Removal of Front Wheel Bearings

Common causes for bearing failure include the following:

1. Mounting or removal abuse.
2. Improper mounting methods.
3. Inadequate or wrong lubricants.
4. Entrance of dirt or water (corrosion and abrasive).
5. Seizing or smearing from overload.
6. Overheating causing tempering.
7. Fatigue pitting.

Of these, the most common cause is that of maladjustment of the bearing. Usually too tight an adjustment resulting in overheating and eventual failure.

1. Raise front of car and support with a safety stand. Remove the hub cap and the tire and wheel assembly to expose the disc brake caliper or brake drum.

2. For disc brakes use a hex drive, unscrew the two large retaining bolts and remove the caliper assembly. Support the caliper assembly so as not to put any strain on the brake hose.

3. Remove the bearing dust cap. Straighten the cotter pin and remove. Unscrew the adjusting nut and remove the washer.

4. Shake the hub assembly from side to side, pull the assembly outward a short distance and then push back quickly. This motion will remove the outer bearing assembly and race from the hub and leave it on the spindle. Remove the pieces from the spindle and place on a clean surface.

5. Leave the disc or drum assembly on the spindle and replace the spindle nut. Pull the assembly from the spindle until the spindle nut retains the disc by contacting the

inner bearing and seal. Pull or jerk the assembly against the spindle nut until the seal and bearing are removed from the hub portion and are retained on the spindle. The disc and hub will be free of the spindle. Remove the bearing or drum and place it on a clean surface. Discard the grease seal.

### Hub Bearing Race Inspection and Removal

1. Thoroughly flush and clean the inside of the hub. Do not allow grease or solvent to contact the braking surface.

2. Inspect the races visibly and feel for roughness while engage matched bearings and races. If anything but a normal wear pattern appears, or if any roughness is felt, replace the distressed race and bearing assembly. In all cases, when a race is replaced, the tapered roller bearing assembly should also be replaced.

3. Using a soft steel drift, engage the exposed edge of the race at one of the slots. Tap the cup from the hub by moving from one slot to the other and avoiding excessive tipping.

### Installation of Hub Bearing Race

1. Wipe the hub recess clean. Lubricate the new bearing race and place it in position over the recess. Make certain that the race faces in the correct position.

2. Tap the race in place slowly with a soft steel drift. Move the drive around the perimeter of the race to prevent cocking or tipping. Bottom the race out on the lip of the hub recess.

### Packing the Wheel Bearing

1. Clean all the old grease from the bearing. The bearing must be clean and dry before the new grease is packed. NEVER MIX WHEEL BEARING GREASES - ALWAYS REPLACE WITH NEW GREASE.

2. Using a bearing packer or packing by hand, pack the bearing full of wheel bearing grease.

### Installation of the Inner Wheel Bearing and Grease Seal

1. To prevent rust and grease run off from the bearings, both the hub and dust cap interior should be given a light coating of grease. NEVER PACK THE HUB FULL OF GREASE AS IT WILL ACT AS AN INSULATOR AND CAUSE HEAT TO BUILD UP RESULTING IN AN EVENTUAL BEARING FAILURE.

2. Insert the packed inner bearing and race assembly into the hub. Lubricate the inner seal lip with a light coating of grease and tap the seal into the hub until it is flush with the top surface of the hub. Strike the outer edge of the seal only.

### Installing the Disc or Drum Assembly

1. Clean the braking surface of all grease and solvents to insure proper braking action.

2. Support the assembly and slide it straight onto the spindle. Be careful not to drag the grease seal or bearing over the spindle threads.

3. When the assembly is in position, insert the outer bearing and race in place. Also insert the washer and screw on the spindle nut. Hand tighten the nut. Do not replace the cotter pin.

4. Replace the disc brake caliper on disc brakes and torque the two bolts to specifications.

### Adjusting Front Wheel Bearings

Proper front wheel bearing adjustment is very important. Improper adjustment can result in abnormal car driving characteristics and unusually quick bearing failure.

1. Snug the spindle nut while turning the disc assembly forward to fully seat the bearing. This will remove any grease or burrs which could cause excessive wheel bearing play later.

2. Back off the nut 1/4 to 1/2 of a turn to the just loose position.

3. Hand tighten the spindle nut, but do not insert the cotter pin.

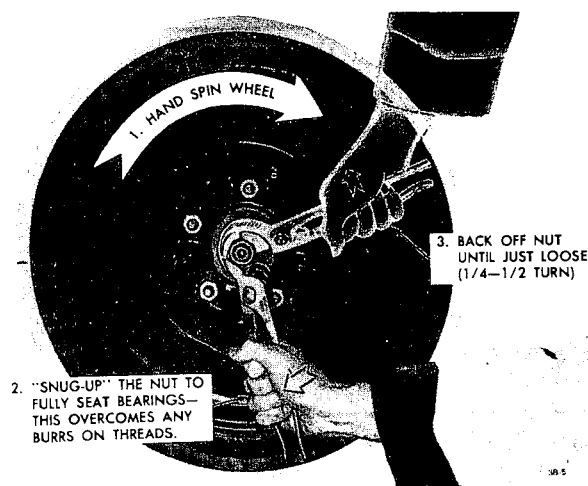

Figure 3B-4 Wheel Bearing Adjustment

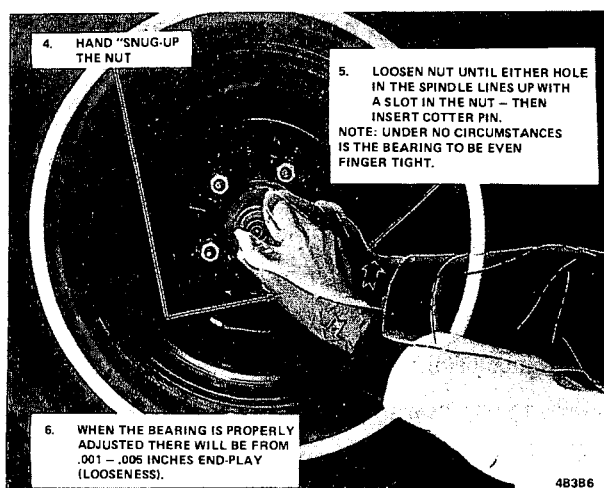

Figure 3B-5 Wheel Bearing Adjustment

4. BACK OFF THE NUT A MINIMUM OF 1/12 OF A TURN AND A maximum of 1/6 of a turn to the appropriate cotter pin hole and insert the cotter pin. UNDER NO CIRCUMSTANCES IS THE SPINDLE NUT TO BE EVEN FINGER TIGHT.

5. Feel the looseness in the hub assembly. There will be from .001 to .005 inches end play.

6. Replace the wheel and tire assembly and torque the wheel nuts to specs.

Most front wheel bearing complaints are results of noise or of a slight vibration of rumble from the front end. Many bearings and races are replaced unnecessarily because of poor diagnosis of normal wear indications. Therefore, unless a bearing is noisy or causing a rough feeling during operation, replacement of the front wheel bearing assemblies is unnecessary.

## MAJOR REPAIR

### REMOVAL AND INSTALLATION OF BALL JOINTS AND STEERING KNUCKLE

#### Removal of Upper Control Arm Ball Joint Assembly

1. Support car on car stand at the frame so front suspension is in full rebound position.
2. Remove front wheel.
3. Remove upper ball stud cotter key.
4. Loosen but do not remove ball stud nut. Nut should be loosened not more than 1/8".

**WARNING: IF BALL STUD NUT IS REMOVED, INJURY COULD RESULT, SINCE HEAVILY COMPRESSED CHASSIS SPRING WILL BE COMPLETELY RELEASED.**

5. Install Tool J-23742-1 between ball stud and turn threaded end of tool until the ball stud is free of steering knuckle. See Figure 3B-6. Remove tool.

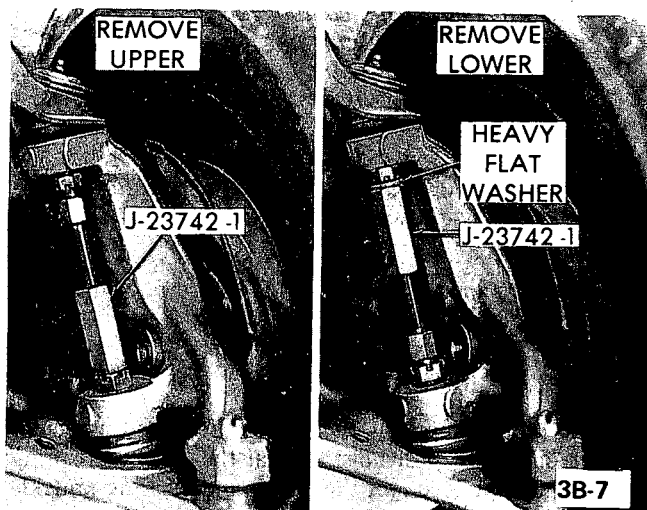

Figure 3B-6 Separating Steering Knuckle from Ball Joints

6. Place jack under lower control arm at spring seat. Raise jack until compression is relieved on upper control arm rubber rebound bumper.

7. Remove the stud nut and lift upper control arm from knuckle.

8. Place a wood block between the upper control arm and the frame to act as a support during the following operations.

9. Center punch the four rivets, as close to the center as possible.

10. Drill a 1/8" hole through the center of the rivets about 1/2 the length of the rivet.

11. Using a 7/32" drill, enlarge the hole, drilling again about 1/2 the length of the rivet.

12. With a chisel, remove the rivet heads.

13. Using a 3/4" punch and hammer, remove the rivets. Remove ball joint. Care must be used not to hit and damage the ball joint seat and rivet holes in the control arm.

#### Installation of Upper Control Arm Ball Joint

An inspection of the tapered holes in the knuckle should be made. If any out-of-roundness, deformation, or damage is noted, the knuckle should be replaced.

1. Install the new ball joint in the upper control arm and attach with the bolt and nut assemblies provided. Insert the bolts from the bottom with the nut on top. Torque to 8 lb. ft.
2. Turn tapered stud so cotter pin hole is fore and aft. Remove the wood block from between the arm and the frame, move the knuckle up by jacking under outer edge of spring seal. Knuckle and brake drum assembly should be in a straight-ahead position.
3. Wipe tapered hole in knuckle and tapered stud free of dirt and grease. Check the tapered hole for cracks or deformation. Assemble stud to knuckle with castellated nut.
4. Never back off nut to align cotter pin holes. *Always tighten nut to next slot that lines up with hole in ball joint stud.*
5. Install new cotter pin.

**CAUTION:** *This front upper control arm ball joint to steering knuckle fastener is an important attaching part in that it could affect the performance of vital components and systems and/or could result in major repair expense. It must be replaced with one of the same part number, or with an equivalent part if replacement becomes necessary. Do not use a replacement part of lesser quality or substitute design. Torque values must be used as specified during reassembly to assure proper retention of this part.*

6. Install wheel and tire and adjust wheel bearing.

#### Lower Ball Joint Removal

1. Raise front of car and place jack stands under frame side rails. Remove tire and wheel assembly.
2. For safety, place a floor jack under the lower control arm as far outboard on the arm as possible to gain max-

imum leverage advantage. Do not place the jack against the arm but about 1/2" below. Now remove cotter pin and loosen (do not remove) nut on lower ball joint tapered stud. Nut should be loosened not more than 1/8". If jack is not used and nut is removed, injury could result since heavily compressed chassis spring will be completely released.

3. Install Tool J-23742-1 between ball studs. See Figure 3B-6.

4. Turn the threaded end of J-23742-1 until the ball stud is free of steering knuckle. Remove tool.

5. Place the jack under the lower control arm at the spring seat. Raise the jack until compression is relieved on the upper control arm rubber rebound bumper. Remove the lower ball joint stud nut. Move the steering knuckle out of the way.

6. Install lower ball joint remover and installer as shown in Figure 3B-7. For H Series also use Tool J-9519-17.

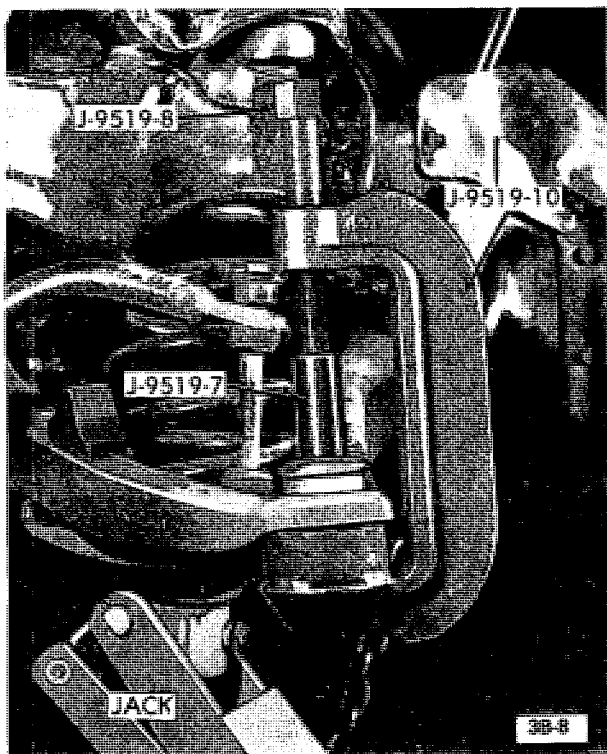

Figure 3B-7 - Lower Ball Joint Remover in Place

7. Tighten Detail J-9519-8 with a socket and handle until ball joint is forced out of the lower control arm.

**CAUTION:** *Ball joint may pop out suddenly.*

#### Lower Ball Joint Installation

An inspection of the tapered holes in the knuckle should be made every time a ball joint is replaced. If any out-of-roundness, deformation or damage is noted, the knuckle should be replaced.

1. Position ball joint in lower control arm and install Tools as shown in Figure 3B-8. For H Series use Tools J-9510-10, J-9519-16 and J-9519-17. Position bleed vent in rubber boot of the new gail joint facing inward.

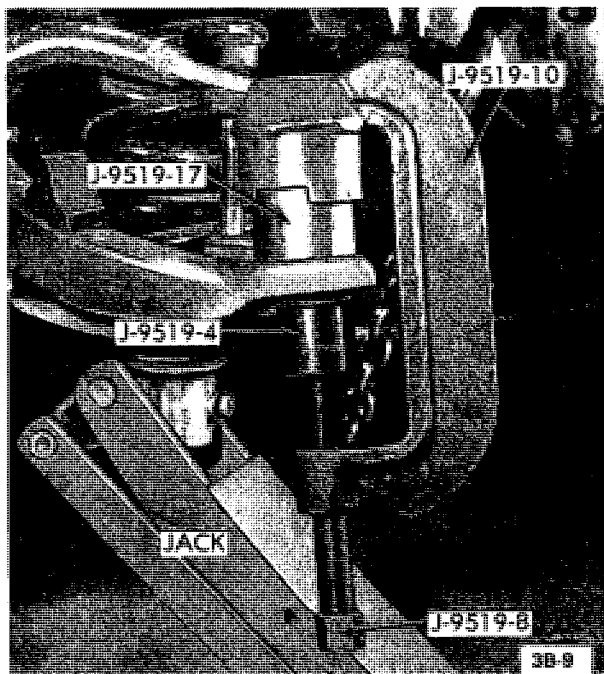

Figure 3B-8 - Lower Ball Joint Installer in Place

2. With a suitable socket and handle force the ball joint into the lower control arm until it is fully seated.

3. Turn the stud so the cotter pin hole is fore and aft. Knuckle should be in a straight-ahead wheel position. Stud and knuckle hole must be free of dirt and grease before assembly. Inspect tapered hole for cracks or deformities.

4. Position the tapered stud in the knuckle and install castellated nut. Tighten the nut to specifications. Never loosen nut to align cotter pin holes. Always tighten nut to next slot that lines up with hole. Install new cotter pin.

**CAUTION:** *This front lower control arm ball joint to steering knuckle fastener is an important attaching part in that it could affect the performance of vital components and systems, and/or could result in major repair expense. It must be replaced with one of the same part number or with an equivalent part, if replacement becomes necessary. Do not use a replacement part of lesser quality or substitute design. Torque values must be used as specified during reassembly to assure proper retention of this part.*

5. Install tire and wheel assembly. Adjust wheel bearing. Remove car stand and lower car.

#### Removal of Steering Knuckle

It is recommended that the vehicle be raised and supported on a twin-post hoist so that the front coil spring remains compressed, yet the wheel and steering knuckle assembly remain accessible. If a frame hoist is used, support the lower control arm with an adjustable jack stand to retain spring in the curb height position.

1. Raise vehicle on a hoist and support the lower control arm.
2. Remove the wheel and tire assembly.



3. Remove the brake caliper and brake disc. Hang the brake caliper assembly from some part of the suspension assembly. Do not allow the unit to hang by the hydraulic line.

On drum brakes remove the drum, braking assembly and backing plate.

4. Remove the splash shield.
5. Remove the tie rod end from knuckle.
6. Remove upper and lower ball stud cotter pins and partially unscrew the ball stud nut so that it protects the end of the ball stud.
7. Place Tool J-23742 in position and force ball studs from steering knuckle tapered hole. Loosen the upper and lower ball stud from the knuckle separately. See Figure 3B-6.
8. The upper control arm will swing up, allowing the upper ball joint stud to come free. The steering knuckle can then be lifted from the lower ball stud or use Tool J-23742 to press out the ball joint.

### Installation of Knuckle

1. Place steering knuckle into place on lower ball stud. Swing the upper control arm down and position the upper ball stud in the tapered knuckle hole.
2. Install ball stud nuts and tighten to specifications. If necessary, tighten one more notch to align cotter pin.

**CAUTION:** *The upper and lower control arm ball joint to steering knuckle fasteners are important attaching parts in that they could affect the performance of vital components and systems, and/or could result in major repair expense. They must be replaced with one of the same part number or with an equivalent part, if replacement becomes necessary. Do not use a replacement part of lesser quality or substitute design. Torque values must be used as specified during reassembly to assure proper retention of these parts.*

3. Install the splash shield and braking assembly.
4. Install outer bearing and spindle washer and nut. Adjust the bearing.
5. Install the brake caliper, on disc brakes cars, and tire wheel assembly.
6. Install tie rod ends.
7. Lower the vehicle to the floor.

### REMOVAL AND INSTALLATION OF UPPER CONTROL ARM ASSEMBLY

#### Removal

1. Raise car with jack under frame. Remove wheel and tire and shock upper attachment.
2. Remove cotter pin from castellated nut on upper ball joint tapered stud.
3. Loosen, but do not remove nut. Force of chassis spring will be tending to disengage ball joint tapered stud from steering knuckle using Tool J-23742-1. See Figure 3B-6.

**WARNING: IF BALL STUD NUT IS REMOVED, INJURY COULD RESULT SINCE HEAVILY COMPRESSED CHASSIS SPRING WILL BE COMPLETELY RELEASED.**

4. With another jack, support car weight under outer edge of lower control arm. Raise jack until compression is relieved on upper control arm bumper and remove castellated nut from ball joint tapered stud.
5. Wire brake and knuckle assembly in place to prevent damage to the brake hose and rotate upper control arm upward and away from knuckle.
6. Remove the upper control arm shaft to frame bracket nuts (carefully note the number, location, and thickness of adjusting shims between the shaft and frame bracket on X-A-B-C-E Series). Remove the control arm assembly. Remove rebound rubber bumper from arm.

On X-A-B-C-E Series, it is necessary in some cases to remove the control arm attaching bolts to allow clearance to remove upper control arm assembly. The attaching bolts are splined into the frame, to remove, proceed as follows:

- a. Tap bolt down.
  - b. Using a box wrench, pry bolt up.
  - c. Remove nut and using a suitable pry bar and block of wood, pry bolts from the frame.
  - d. Remove arm from the car.
7. Inspect stud hole in knuckle. If elongated or damaged, replace knuckle.

### Installation

Replace the bolts only with equivalent parts.

1. Position upper control arm attaching bolts loosely in the frame and install pivot shaft on the attaching bolts.
2. Using a free running nut instead of the regular locknut, tighten both nuts until serrated bolts are reseated.
3. Remove free running nuts and install the regular lock nuts.

**CAUTION:** *Fasteners in steps 1, 2, and 3 are important attaching parts in that they could affect the performance of vital components and systems, and/or could result in major repair expense. They must be replaced with one of the same part number or with an equivalent part if replacement becomes necessary. Do not use a replacement part of lesser quality or substitute design. Torque values must be used as specified during reassembly to assure proper retention of these parts.*

1. Assemble upper control arm and shaft assembly to bracket, making certain the number, thickness and location of adjusting shims between shaft and bracket are correct. Assemble rubber rebound bumper to arm. Torque shaft to bracket nuts to specifications. Those bolts may be torqued from within the engine compartment through the

use of a standard 11/16"-1/2" drive socket and J-1313 Torque Wrench or J-22618 Adapter.

2. Make sure stud and tapered hole in knuckle are free of dirt and grease. Inspect tapered hole for cracks or deformations. Spindle should be in a straight-ahead wheel position when the stud is inserted. Assemble tapered stud to knuckle with cotter pin holes fore and aft. Install castellated nut. Torque to specifications. *Never loosen nut to align cotter pin holes. Always tighten nut to next slot that lines up with hole.* Install new cotter pin.

3. With car at curb load, loosen upper control arm bushing to shaft bolts and bounce front end of car, also reinstall shock upper attachment. Retorque bolts to specifications.

4. Install wheel. Check and adjust front end alignment. Adjust wheel bearings. When working in the area of the front upper control arm, make certain that the rubber water deflectors on fender skirt are securely attached in their original positions when the work is completed. If reasonable care is exercised in removing the fasteners for these rubber deflectors, they may be satisfactorily reused.

### REMOVAL AND INSTALLATION OF LOWER CONTROL ARM ASSEMBLY

#### Removal

1. Remove shock absorber lower attachment, coil spring and stabilizer link.
2. Remove ball stud from steering knuckle.
3. Remove two nuts and bolts securing control to frame. For H Series mark the position of the front alignment cam bolts before loosening nuts to aid in ease of reassembly.
4. Remove the control arm from vehicle.
5. If lower control arm is to be replaced, remove the rubber bumper and attaching nut.

#### Installation

1. Install new arm assembly with the arm to frame bolt head to the front of car. Install rubber side bumper to arm. Torque to specifications. Make sure bolts point to rear of car.
2. Reinstall coil spring and stabilizer link.
3. With the car at curb load, tighten the control arm to frame attaching bolt nuts to specifications. This operation must be done with the car off the hoist and at curb weight. If the nuts are torque while the car is still on the hoist and the suspension is in an unloaded position, the bushings will be stressed when the car is finally lowered and suspension takes a loaded position.

**CAUTION:** *This front lower control arm to frame fastener is an important attaching part in that it could affect the performance of vital components and systems, and/or could result in major repair expense. It must be replaced with one of the same part number or with an equivalent part, if replacement becomes necessary. Do not use a replacement part of lesser quality or substitute design. Torque values must be used as specified during reassembly to assure proper retention of this part.*

### REMOVAL AND INSTALLATION OF UPPER CONTROL ARM BUSHINGS

#### Removal

If the upper control arm shaft end nuts are tack welded in place, the bushings cannot be replaced, therefore the complete upper control arm assembly must be replaced.

1. Raise car with jack under frame. Remove wheel and tire.

2. Remove cotter pin from castellated nut on upper ball joint tapered stud.

3. Loosen, but do not remove nut. If ball stud is removed, injury could result since heavily compressed chassis spring will be completely released.

4. Install Tool J-23742-1 between ball stud and turn threaded end until the ball stud is free of steering knuckle. See Figure 3B-6.

5. With another jack, support car weight under outer edge of lower control arm. Raise jack until compression is relieved on upper control arm bumper and remove castellated nut from ball joint tapered stud.

6. Wire brake and knuckle assembly in place to prevent damage to the brake hose, and rotate upper control arm upward and away from knuckle.

7. Remove the upper control arm shaft to frame bracket nuts, carefully noting the number, location, and the thickness of adjusting shims between the shaft and frame bracket. Remove the control arm assembly.

#### H Series

1. Place the control arm in a vise and install tools J-21474-3, J-21474-4, J2-1474-13 and J-21474-5.

2. Tighten the bolt head until the bushing is free of control arm.

3. Separate the tools and discard the bushing.

#### X-A-B-C-E Series

1. Using Special Tools J-22269-5 and J-5888-3 and one of the support shaft bolts as shown in Figure 3B-9, tighten

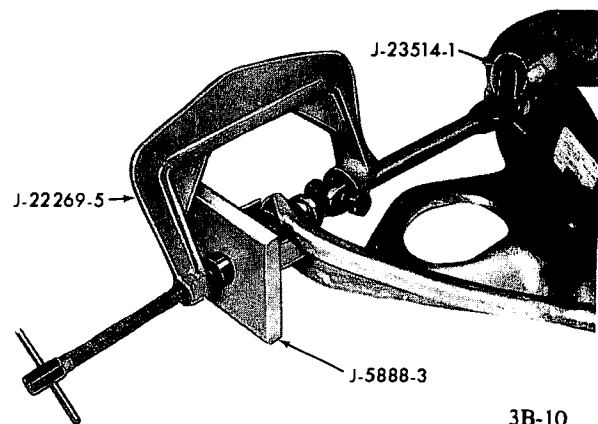

Figure 3B-9 - Installing Front Upper Control Arm Bushing Keeper

2. Turn control arm around and install Tool J-22269-5 over J-23514 as shown in Figure 3B-10 and tighten screw against J-5888-3 to remove bushing.

3. To remove bushing from other side, install Special Tools J-5888-3 and J-22269-5 as shown in Figure 3B-11 and turn forcing screw until bushing is pushed out.

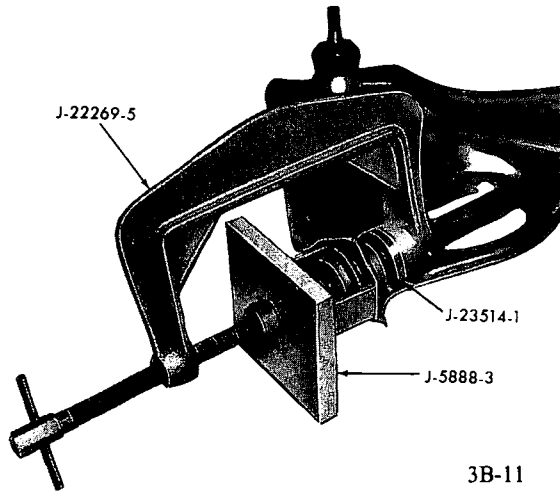

Figure 3B-10 - Removing First Upper Control Arm Bushing Front or Rear

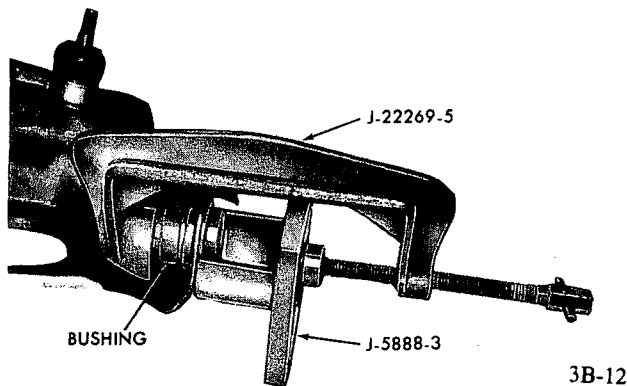

Figure 3B-11 - Removing Second Upper Control Arm Bushing Front or Rear

### Installation H Series

1. Start a new bushing in place and install Tools J-21474-3, J-21474-4, J-21474-13 and J-21474-5.
2. Tighten the bolt head until the bushing is seated in the control arm.
3. Remove the tools from the control arm.

### X-A-B-C-E Series

1. Install first bushing with Special Tools J-22269-5, J-5888-3 and J-23514-2 as shown in Figure 3B-12.
2. Install the support shaft and bushing on the other side of the control arm with Special Tools J-22269-5 and Adapter J-23514-2 as shown in Figure 3B-13. Mounting

surface of shaft should be in same relative position to arm as when removed.

3. Assemble upper control arm and shaft assembly to bracket, making certain the number, thickness and location of adjusting shims between shaft and bracket are correct. Assemble rubber rebound bumper to arm. Torque shaft to bracket nuts to specifications. Those bolts may be torqued from within the engine compartment through the use of a standard 11/16"-1/2" drive socket and J-1313 Torque Wrench or J-22618 Adapter.

4. Make sure stud and tapered hole in knuckle are free of dirt and grease. Inspect tapered hole for imperfections. Spindle should be in a straight-ahead wheel position when the stud is inserted. Assemble tapered stud to knuckle with cotter pin holes fore and aft. Install castellated nut. Torque to specifications. Never loosen nut to align cotter pin holes. Always tighten nut to next slot that lines up with hole. Install new cotter pin.

5. With car at curb load, loosen upper control arm bushing to shaft bolts and bounce front end of car. Retorque bolts to specifications.

6. Install wheel.

7. Check and adjust front end alignment.

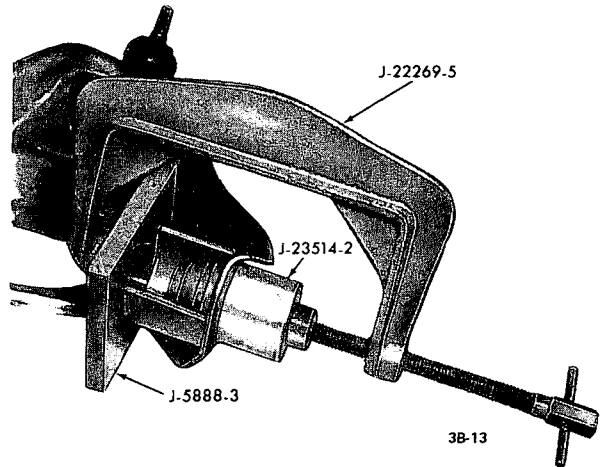

Figure 3B-12 - Installing Upper Control Arm First Bushing

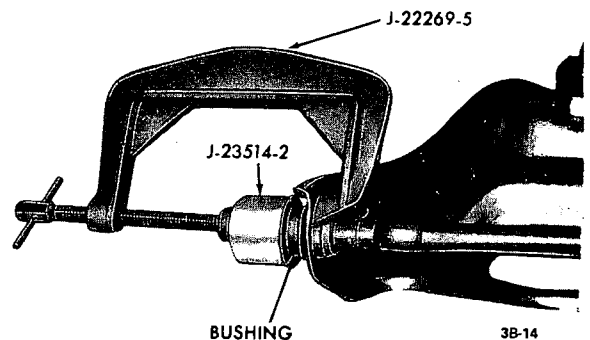

Figure 3B-13 - Installing Upper Control Arm Second Bushing

## REMOVAL AND INSTALLATION OF LOWER CONTROL ARM BUSHINGS

### H Series Removal

1. Remove control arm as described.
2. Place the control arm in a vice and install tools, J-21474-2, J-21474-3, J-21474-4, J-21474-5 and J-22323-1.
3. Tighten the bolt head until the bushing is pushed free of control arm.
4. Separate the tools and discard the bushing.

### X-A-B-C-E Series Removal

1. Raise car with jack under frame.
  2. With the vehicle supported by the frame so that the control arms hang free, remove the lower shock absorber bolts and push the shock absorber up through the coil spring.
  3. Remove the front stabilizer rod link from the lower control arm.
  4. Position Tool J-23028 to a suitable jack and place under lower control arm bushing so that bushings seat in the grooves of the tool. See Figure 3B-14.
  5. Install a chain around the control arm and through a coil of the spring as a safety measure.
  6. Remove the control arm pivot bolts and nuts. (Remove rear bolt first). If bolts "hang-up" between control arm, and frame, use a pry bar to move the control arm so that bolts can be removed. Do not "hammer" bolts out.
  7. Lower control arm by slowly releasing jack.
  8. Install J-21474-12 spacer. See Figure 3B-15.
- CAUTION:** Do not attempt to remove bushing without having the spacer in position. Distortion to the arm will result.
9. Install remaining tools as shown in Figure 3B-15 and turn hex bolt and nut until the old bushing is removed.
  10. Remove tools and discard bushing.



Figure 3B-14 - Removing Spring

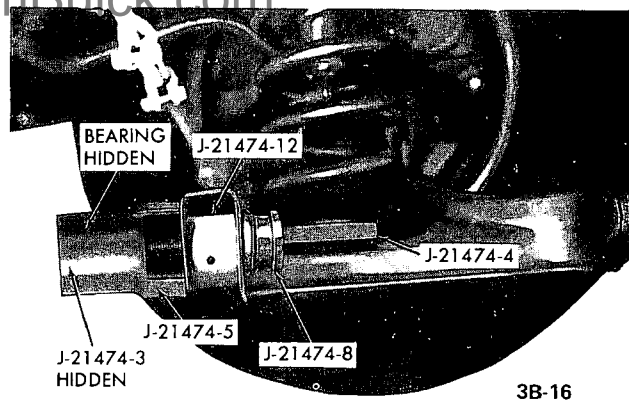

Figure 3B-15 - Removing Lower Control Arm Bushing

### H Series Installation

1. Start a new bushing in position and install tools, J-21474-3, J-21474-4, J-21474-5, J-21474-13 and J-22323-1.
2. Tighten the bolt head until the bushing is seated in the control arm.
3. Remove the tools from the control arm.
4. Reinstall control arm as described.

### X-A-B-C-E Series Installation

1. Start a new bushing in place and position tools as shown in Figure 3B-16.

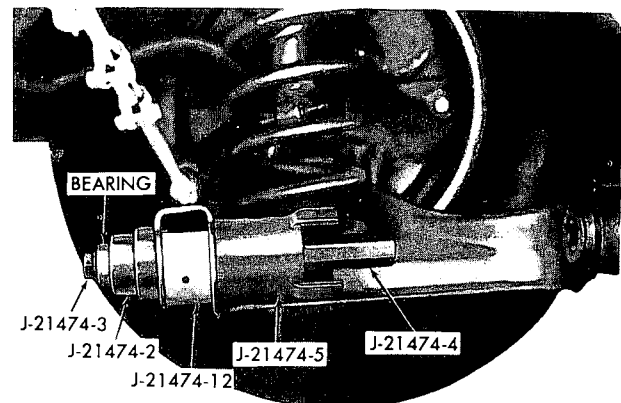

3B-17

Figure 3B-16 - Installing Lower Control Arm Bushing

Spacer J-21472-12 should still be in position.

2. Turn hex bolt and nut until new bushing is properly seated.
3. Remove tools.
4. After installing a new bushing it will be necessary to tack weld the front bushing to the control arm on A-B-C-E Series. See Figure 3B-17.

**CAUTION:** ARC WELD ONLY. Heat transmitted by acetylene welding could result in damage to the bushing. Weld build-up must not exceed .030 inch above the face of the bushing outer sleeve.

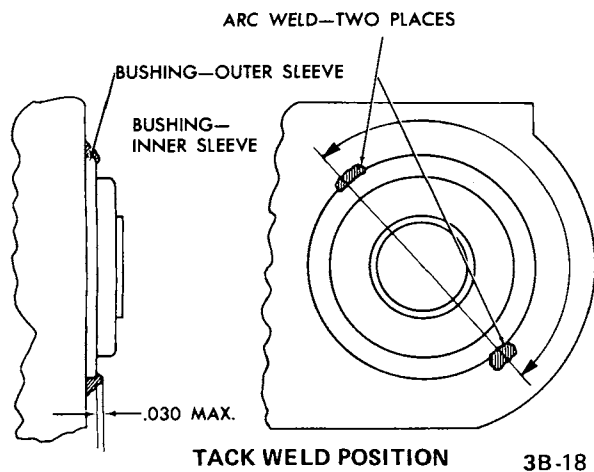

Figure 3B-17

**CAUTION:** Eye protection must be worn when breaking the tack welds and again during the welding operation.

5. Position Tool J-23028 under bushings and install control arm to vehicle frame.

6. Install pivot bolts (front bolt first) and nuts and torque nuts to specifications. Remove safety chain.

Mandatory installation of pivot bolts is in direction from front to rear. The bolt heads will be to the front of the vehicle.

7. Pull shock absorber lower and through the lower control arm and install mounting bolts. Torque bolts to specifications.

8. Install stabilizer rod link and torque nut to specifications.

9. Lower jack and remove Tool J-23028.

10. Lower vehicle to floor.

11. Check and adjust front end alignment.

## REMOVAL AND INSTALLATION OF FRONT SPRING

### H Series Removal

1. With shock absorber removed and stabilizer bar removed, raise the vehicle and place jackstands under front braces.

2. Remove the wheel and tire assembly.

3. Place a hydraulic floor jack under the lower control arm and support the arm. Use a block of wood between the control arm and the jack.

**CAUTION:** Install a chain through the spring and around the control arm as a safety measure.

4. Remove the lower ball stud from the steering knuckle. "See Ball Joint Removal".

5. Remove the tie rod end from the steering knuckle.

**WARNING:** THE LOWER CONTROL ARM KEEPS THE SPRING COMPRESSED USE CARE WHEN LOWERING.

6. Lower the control arm by slowly releasing jack until the spring can be removed.

### X-A-B-C-E Removal

1. Raise vehicle on hoist.

2. Remove the two shock absorber screws and push shock up through control arm and into spring.

3. With the vehicle supported so that the control arms hang free, place Tool J-23028 into position cradling the inner bushings. See Figure 3B-14.

**CAUTION:** Tool J-23028 should be secured to a suitable jack.

4. Remove stabilizer to lower control arm attachment.

5. Raise the jack to remove the tension on the lower control arm pivot bolts. Install a chain around the spring and through the control arm as a safety measure. Remove nuts and bolts - (Remove rear bolt first).

6. Lower control arm by slowly lowering jack.

7. When all compression is removed from the spring remove safety chain and spring.

**CAUTION:** Do not apply force on the lower control arm and ball joint to remove spring. Proper maneuvering of the spring will allow for easy removal.

### Installation

**CAUTION:** Fasteners in the following steps are important attaching parts in that they could affect the performance of vital components and systems, and/or could result in major repair expense. They must be replaced with one of the same part number, or with an equivalent part if replacement becomes necessary. Do not use a replacement part of lesser quality or substitute design. Torque values must be used as specified during reassembly to assure proper retention of these parts.

### H Series Installation

1. Properly position spring in spring tower and on control arm and lift control arm with hydraulic jack.

2. Guide the lower control arm ball stud into the steering knuckle and install nut. Torque nut to specifications and insert cotter pin. Remove the safety chain.

Do not back off nut to insert cotter pin. Advance nut to the next slot that lines up with the hole in the stud.

3. Install the tie rod end to the steering arm.

4. Install the shock absorber.

5. Install the stabilizer bar if removed.

6. Install the wheel and tire assembly.
7. Remove the vehicle from the jackstands and lower to the floor. Install the upper end of the shock absorber.

#### X-A-B-C-E Series Installation

1. Properly position spring on the control arm and lift control arm with Special Tool J-23028.

Take care that the spring is properly installed as shown in Figures at end of this section.

2. Position control arm into frame and install pivot bolts (front bolt first) and nuts. Torque to specifications and lower jack.

**CAUTION:** *In order to maintain adequate steering linkage clearance, refer to mandatory bolt direction of installation as shown in Art at the back of this section.*

3. Replace the stabilizer bar link and shock absorber. Lower vehicle to floor.
4. Torque all fasteners to specifications.

#### REMOVAL AND INSTALLATION OF SHOCK ABSORBERS

##### Removal

1. Remove upper shock absorber attaching nut, grommet retainer and grommet.
2. Remove the lower retaining screws. Lower shock through hole in lower control arm.

##### Installation

1. Select the correct shock absorber for the particular car model. Refer to Master Chassis Parts Catalog for correct absorber. Substitution of an incorrectly calibrated shock absorber will adversely affect car performance.
2. With shock upright in vise, push and pull shock rod through its full travel several times to pump out any air which might be trapped in the inner Cylinder. Keep shocks upright until installed. It is a good idea to replace the shock absorber rubber grommets whenever a shock is removed or replaced.

Assemble lower grommet retainer and grommet on shock stem. Extend shock and install through lower control arm.

3. Install shock, lower attaching screws. Torque to specifications.

4. Assemble top grommet, grommet retainer, and nut on stem. Torque to specification.

#### REMOVAL AND INSTALLATION OF STABILIZER BAR

**CAUTION:** *Stabilizer bar fasteners are important attaching parts in that they could affect the performance of vital components and systems, and/or could result in major repair expense. They must be replaced with one of the same part number or with an equivalent part if replacement becomes necessary. Do not use a replacement part of lesser quality or substitute design. Torque values must be used as specified during reassembly to assure proper retention of these parts.*

##### Stabilizer Shaft, Removal and Replacement

Disconnect stabilizer links and disconnect the two frame-to-shaft insulator mounts and brackets.

To install, position insulator mounts and brackets over shaft and connect bracket to frame.

Torque bracket bolts to specifications. Connect stabilizer links. Do *not* lubricate insulator mounts.

##### Stabilizer Bracket and Insulator, Removal and Replacement

Stabilizer brackets should be replaced if damaged, and rubber insulator mounts replaced if deteriorated.

Replace by supporting stabilizer shaft in position and replacing brackets and mounts one at a time. Torque bracket bolts specification.

##### Stabilizer Link Removal and Replacement

1. Remove nut from lower end of link. Remove link, spacer, retainers and grommets.
2. Inspect link and grommets.
3. Install grommets dry and use care to center the grommets in the seats on stabilizer shaft and hole in control arm. Also, center the retainers on grommets before tightening link nut.
4. Tighten link nut.

**BOLT TORQUE SPECIFICATIONS**

Use a reliable torque wrench to tighten the parts listed to insure tightness without straining or distorting parts. These specifications are for clean and lightly-lubricated threads only; dry or dirty threads produce increased friction which prevents accurate measurement of tightness.

Part	Location	Torque Lb. Ft.
Screws	Front Shock to Lower Control Arm	
	All Series .....	20
Nut	Front Shock to Frame	
	All Series .....	8
Screw	Stabilizer Bushing to Frame	
	All Series .....	24
Nut	Upper Control Arm Shaft to Frame	
	H Series .....	60
	X Series .....	50
	A-B-C-E Series .....	70
Nut	Upper Ball Joint to Knuckle	
	H Series .....	30
	X-A-B-C-E Series .....	60
Nut and Bolt	Lower Control Arm to Frame	
	H Series .....	Nut 125
	X Series .....	100
	A-B-C-E Series .....	Bolt 115 Nut 95
Nut	Lower Ball Joint to Knuckle	
	H Series .....	60
	X Series .....	80
	A-B-C-E Series .....	90
Nut or Bolt	Stabilizer Link to Lower Control Arm	
	H-X-A-B-C-E Series .....	12
Nut	Idler Arm to Frame	
	H Series .....	30
	X Series .....	50
	A-B-C-E Series .....	40
Nut	Tie Rod End to Steering Knuckle	
	All.....	35
Nut	Lower Control Arm Bumper	
	All.....	17

**DIMENSIONAL SPECIFICATIONS**

**Stabilizer Bar Diameter**

Series	Standard	Optional
H Series	1.00	1.00
X Series V-8 L-6, V-6	.94	1.00
	.88	.94
X Series SR V-8 L-6, V-6	1.00	1.00
	.94	.94
A Series less Wagon A Series Wagon	.88	1.00
	.94	1.00
B Series (less Wagon) 350 and C Series B Series (less Wagon) 455 B Series Wagon and E Series	.94	1.00
	.97	1.00
	1.00	1.00

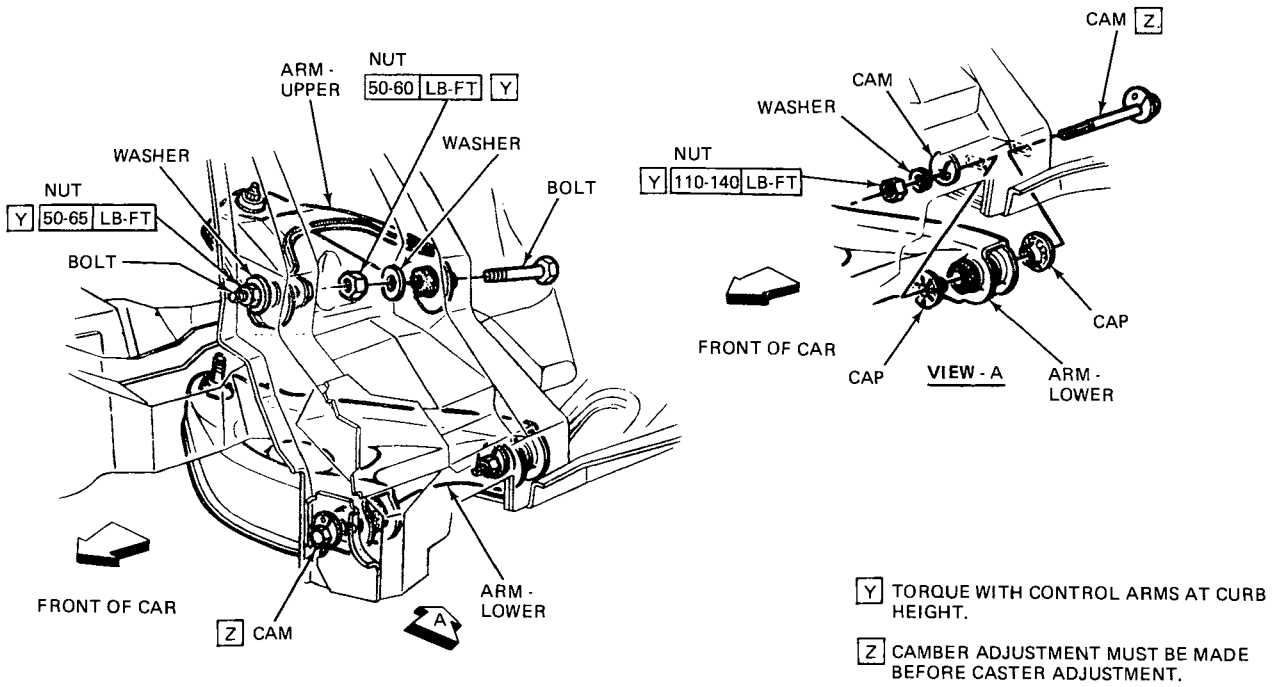

5B3B1

Figure 3B-18 - H Series Control Arms

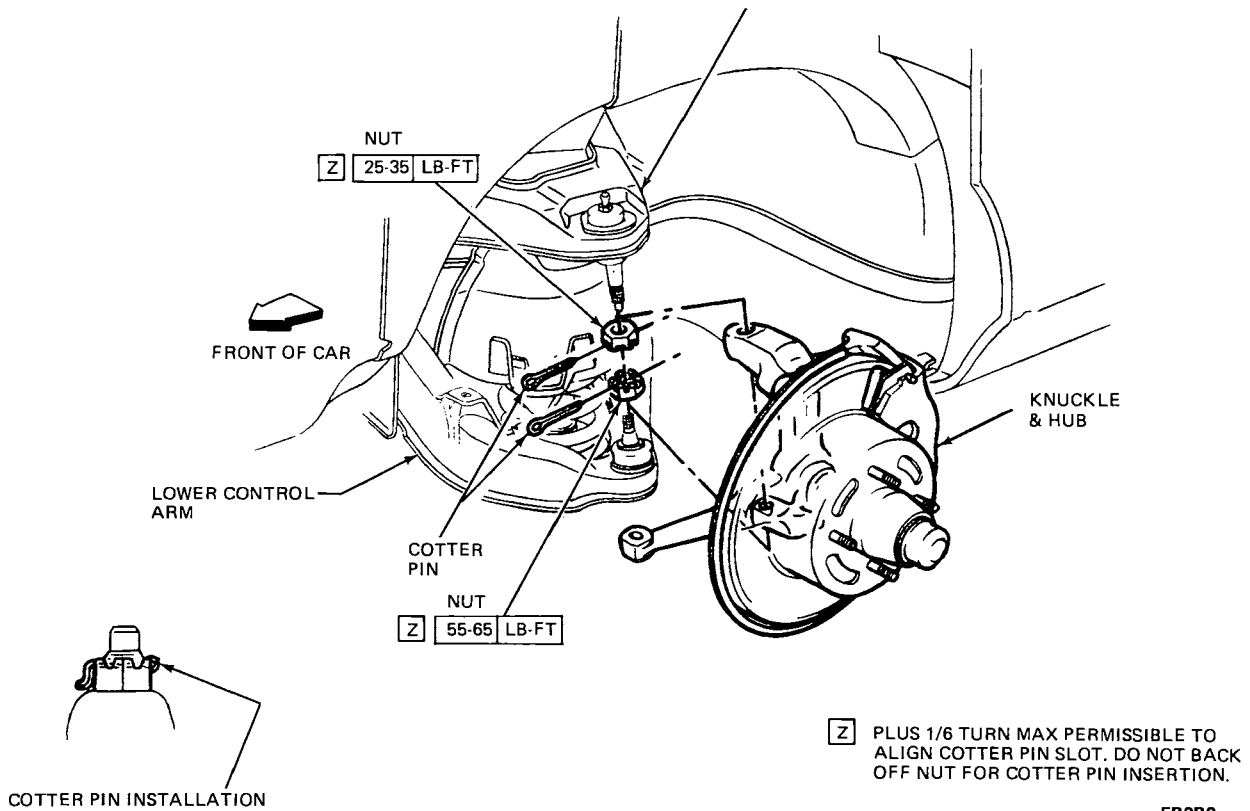

5B3B2

Figure 3B-19 - H Series Steering Knuckle



AFTER ASSEMBLY, END OF SPRING COIL MUST BE VISIBLE THRU INSPECTION DRAIN HOLE. THE HOLE MUST NOT BE COMPLETELY COVERED.

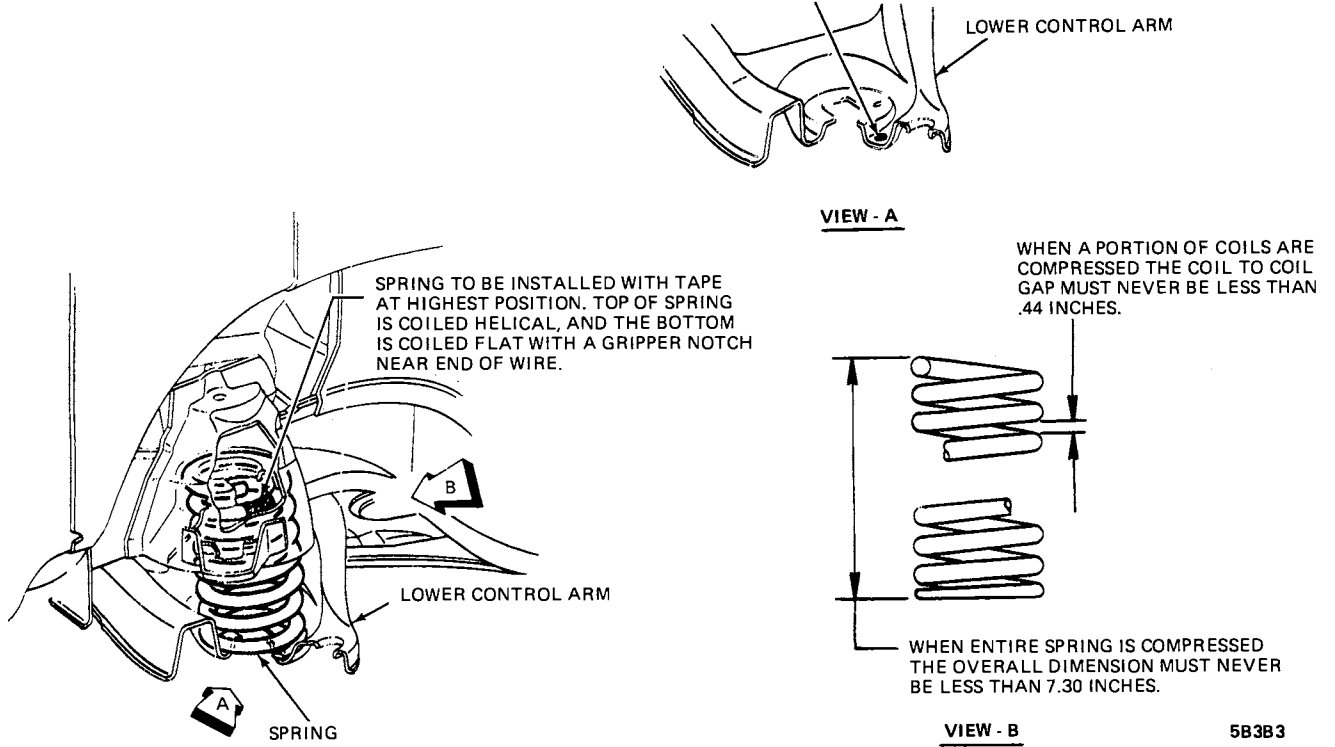

Figure 3B-20 - H Series Front Coil Spring

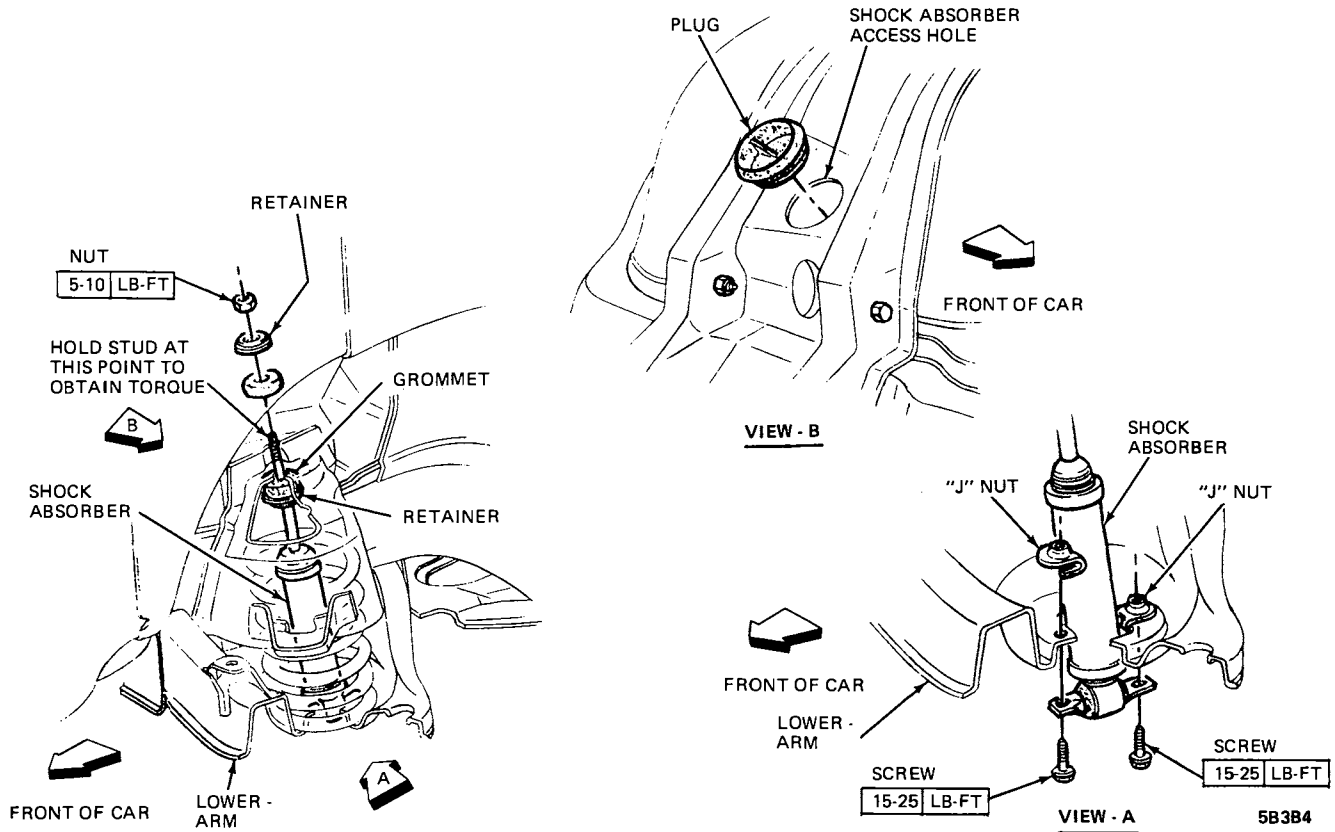
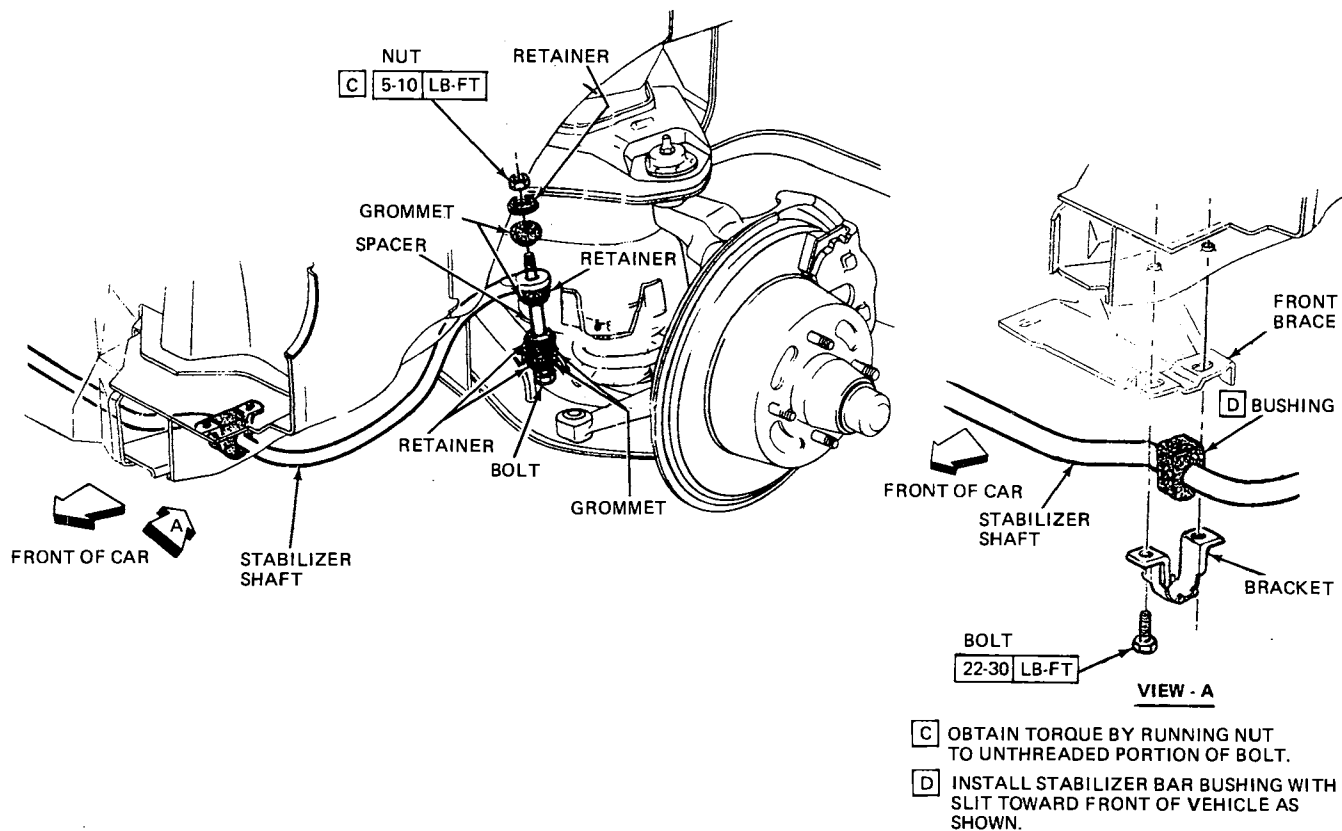
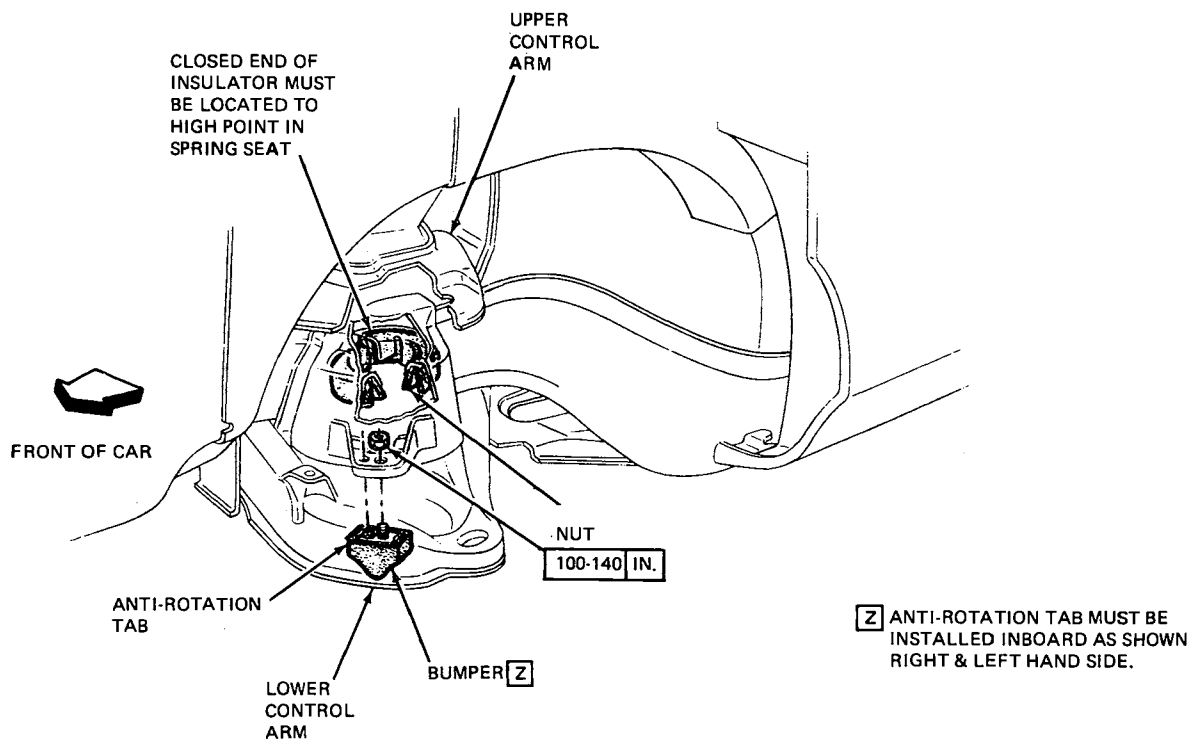

Figure 3B-21 - H Series Front Shock Absorber



5B3B5

Figure 3B-22 - H Series Front Stabilizer Shaft



5B3B23

Figure 3B-23 - H Series Control Arm Insulator and Bumper

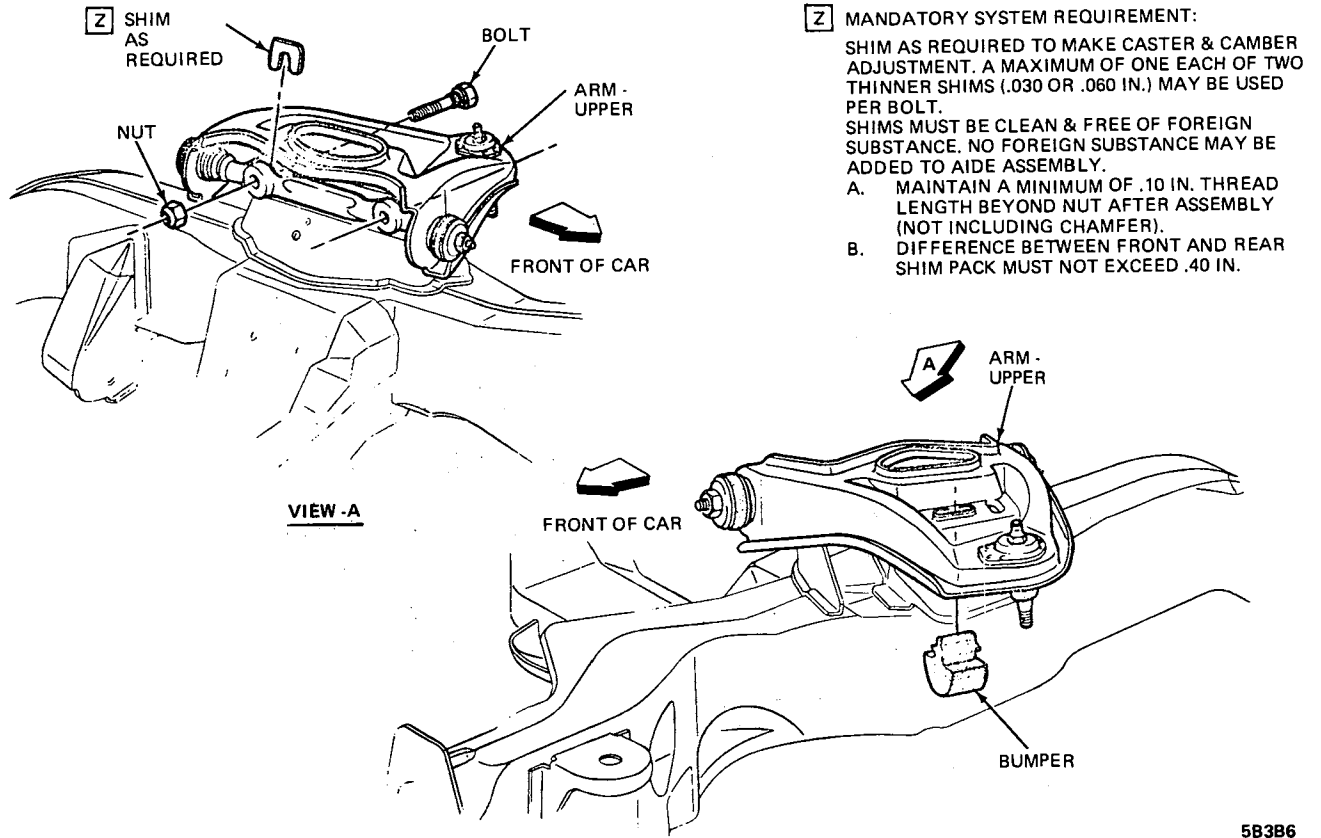

5B3B6

Figure 3B-24 - X Series Upper Control Arm

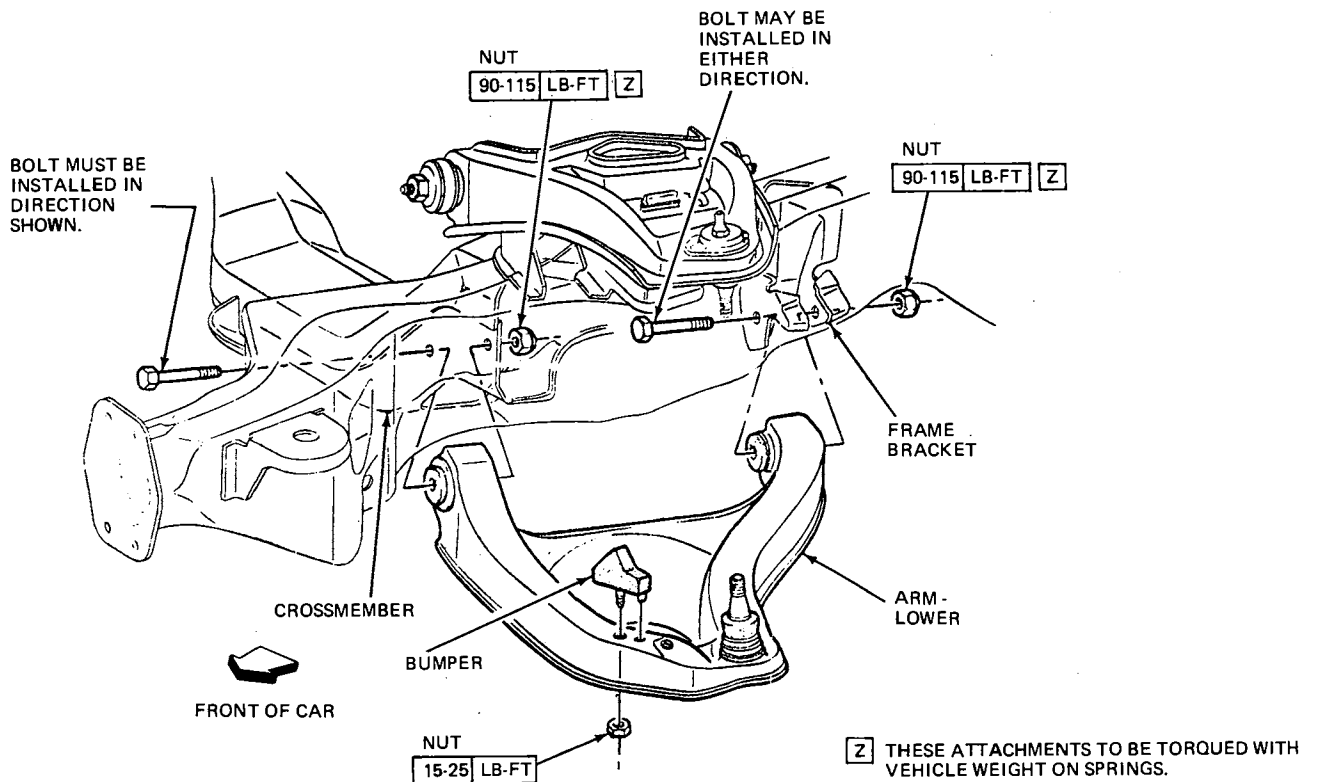

5B3B7

Figure 3B-25 - X Series Lower Control Arm

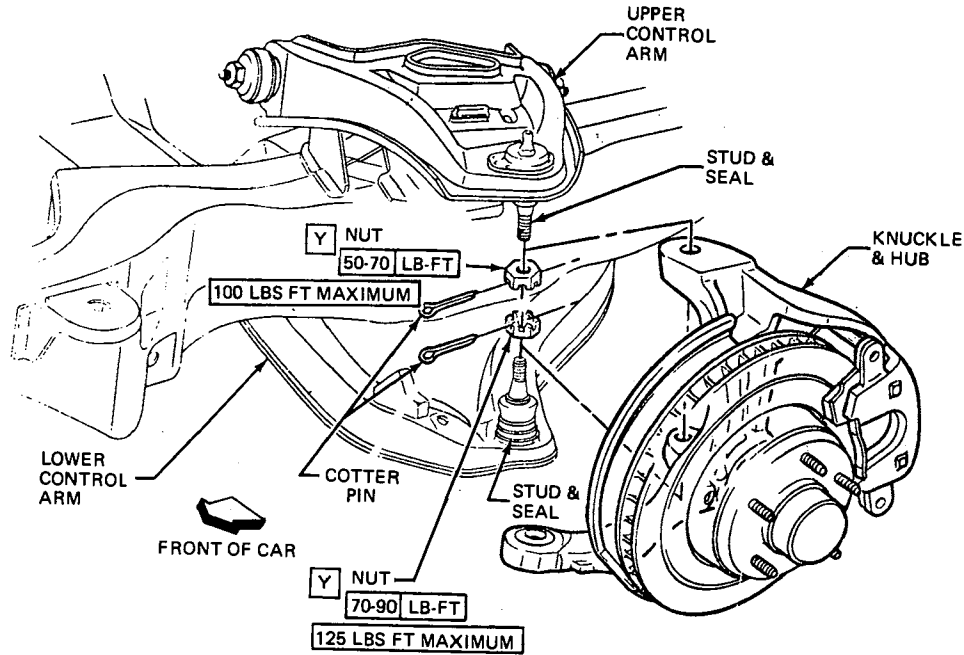

Y PERMISSIBLE TO ALIGN COTTER PIN SLOT (1/8 TURN MAXIMUM). DO NOT BACK OFF NUT FOR COTTER PIN INSERTION.

5B3B26

Figure 3B-26 - X Series Steering Knuckle

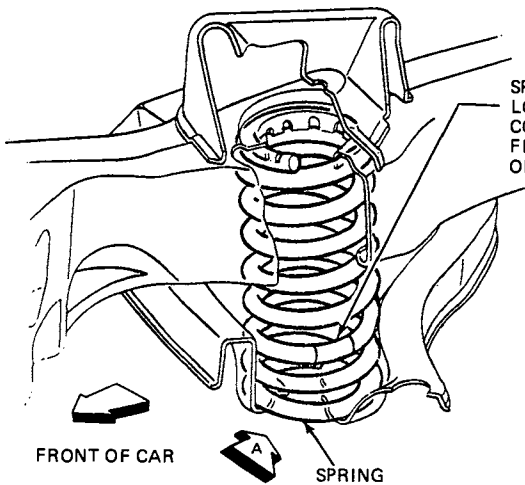

SPRING TO BE INSTALLED WITH TAPE AT LOWEST POSITION. BOTTOM OF SPRING IS COILED HELICAL, AND THE TOP IS COILED FLAT WITH A GRIPPER NOTCH NEAR END OF WIRE.

AFTER ASSEMBLY, END OF SPRING COIL MUST COVER ALL OR PART OF ONE INSPECTION DRAIN HOLE. THE OTHER HOLE MUST BE PARTLY EXPOSED OR COMPLETELY UNCOVERED.

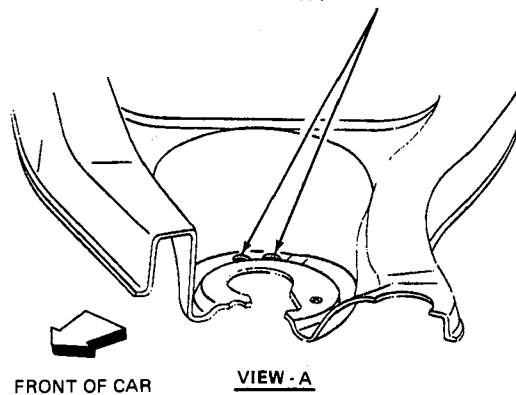
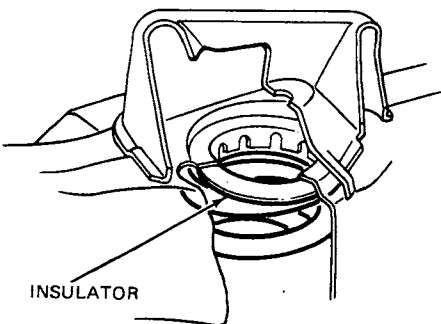

5B3B9

Figure 3B-27 - X Series Front Coil Spring

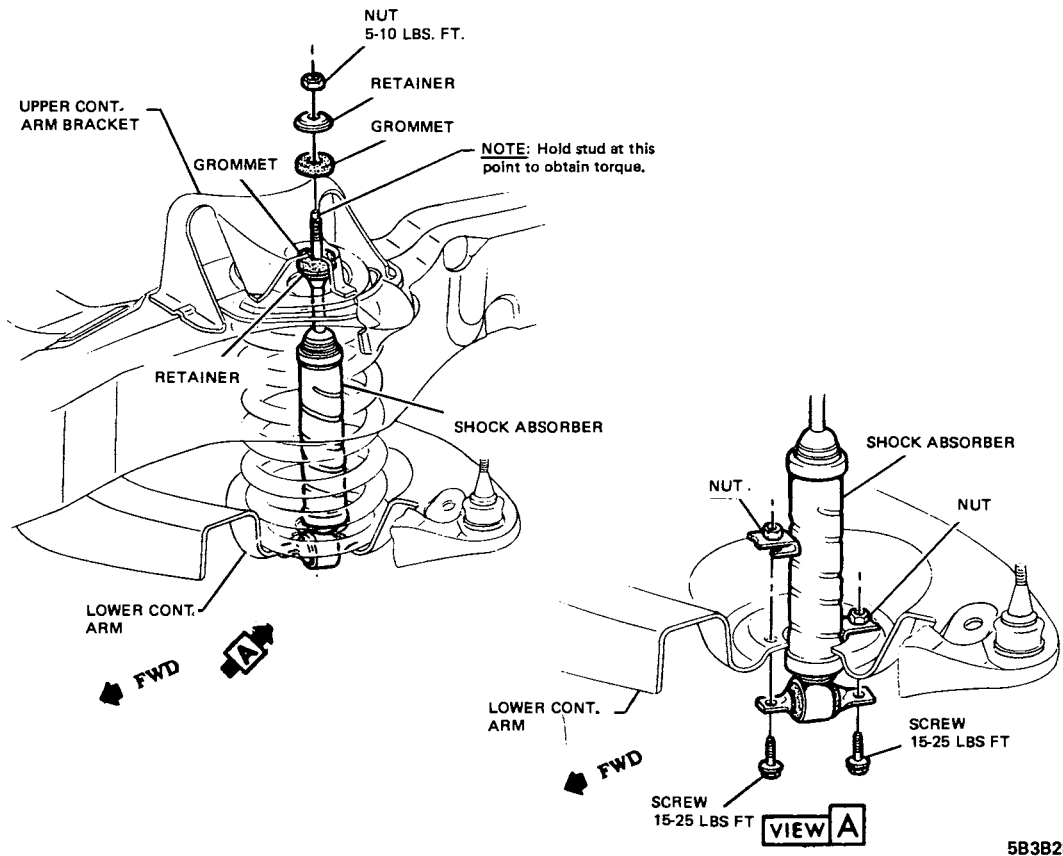

5B3B28

Figure 3B-28 - X Series Front Shock Absorber

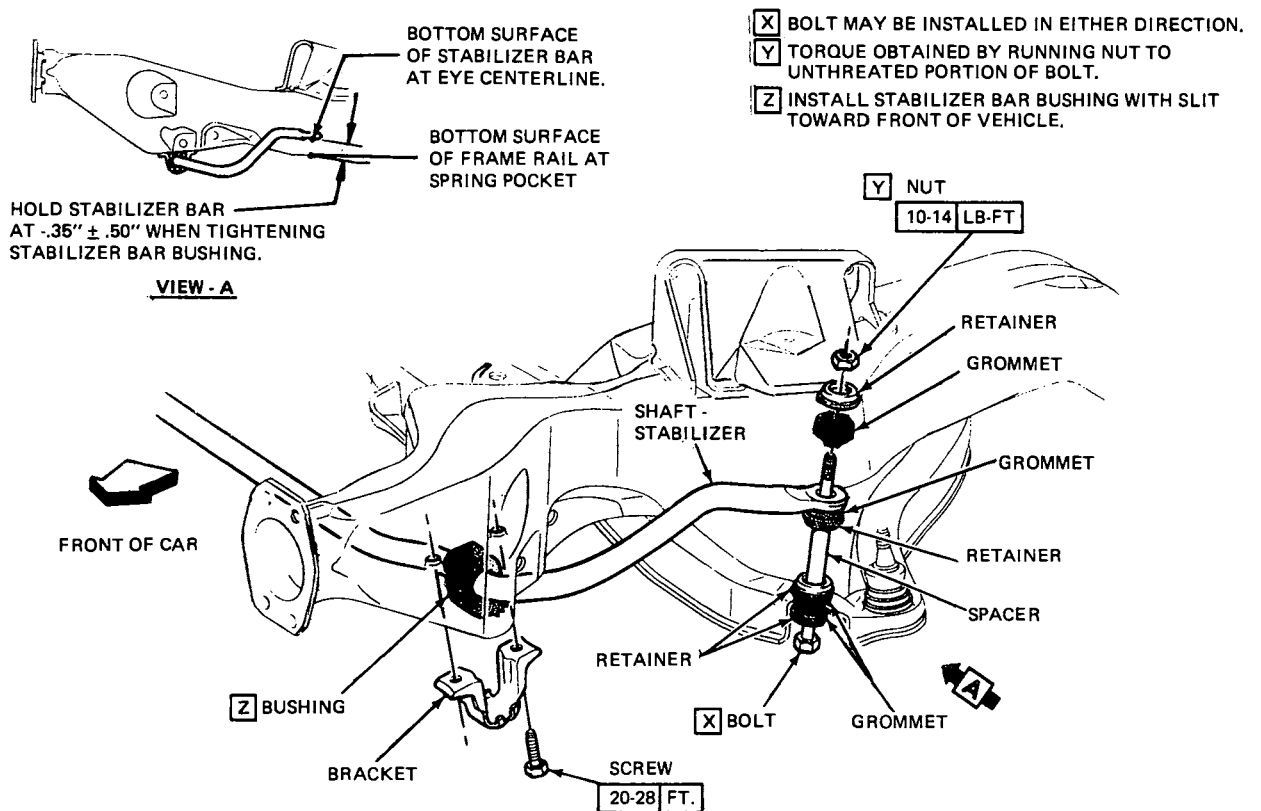

5B3B29

Figure 3B-29 - X Series Front Stabilizer Shaft

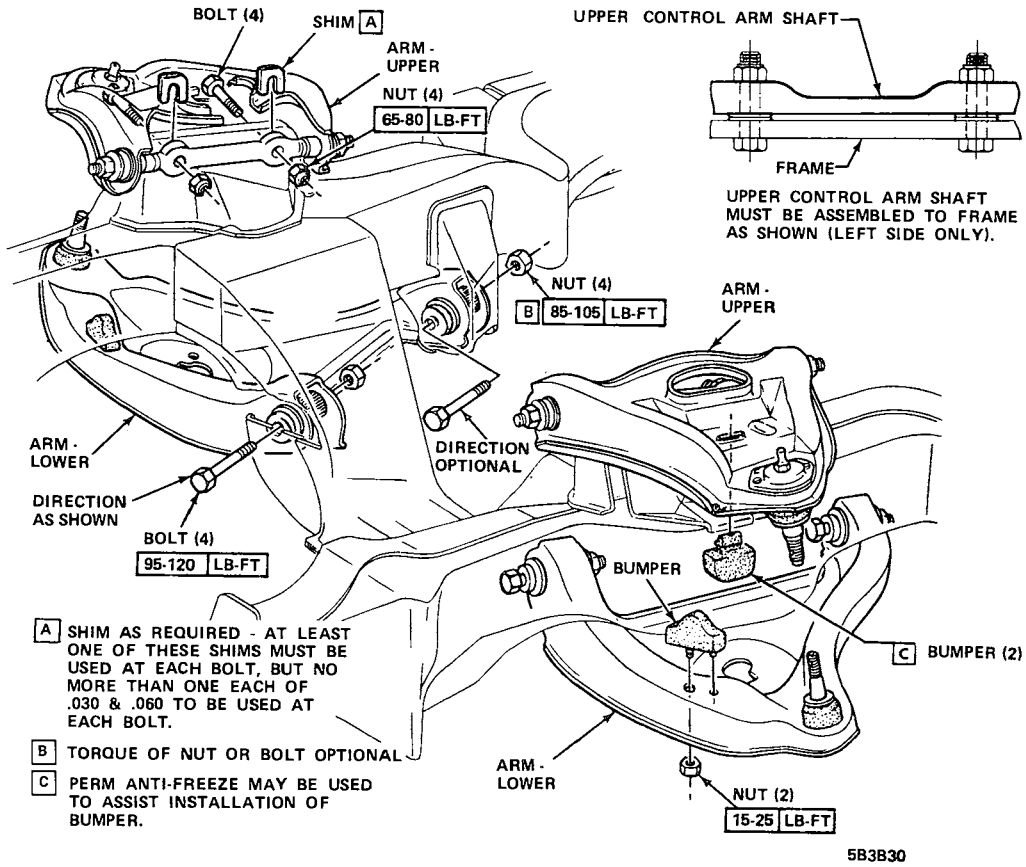

Figure 3B-30 - A Series Control Arms

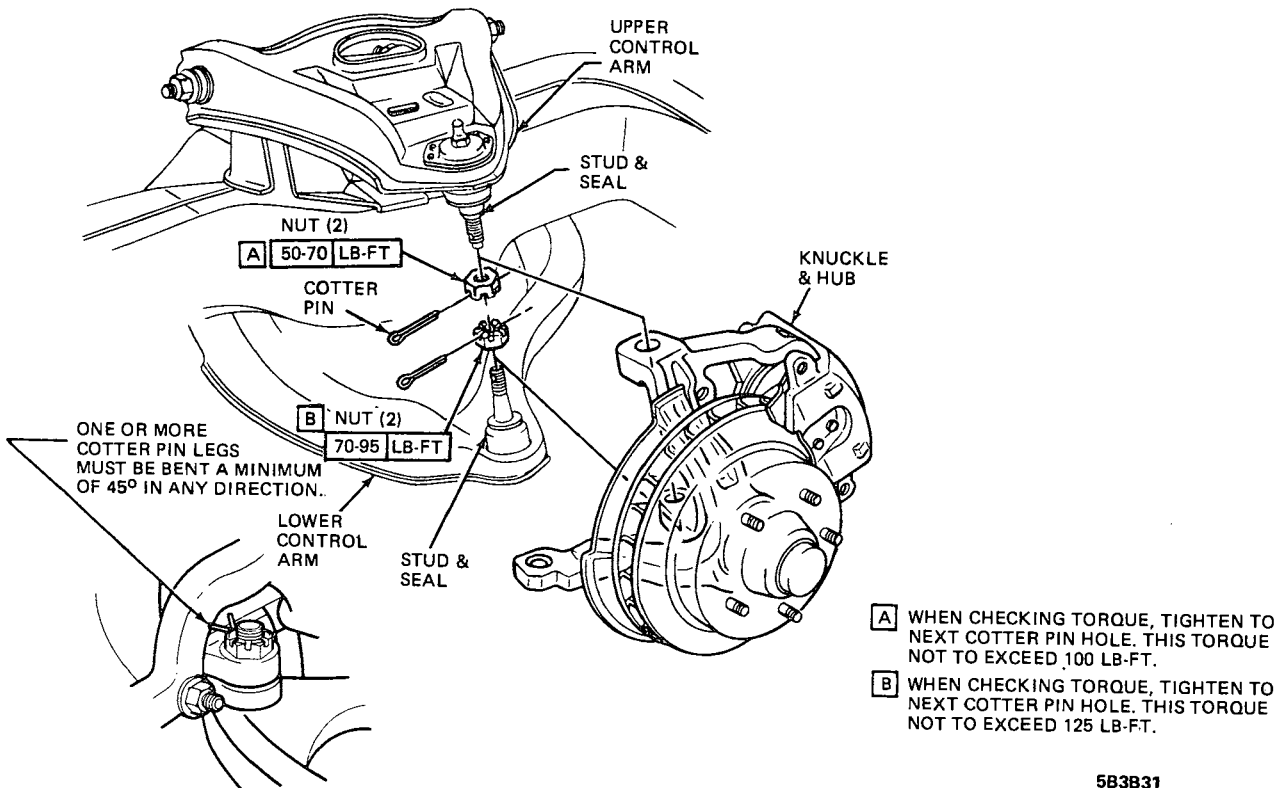
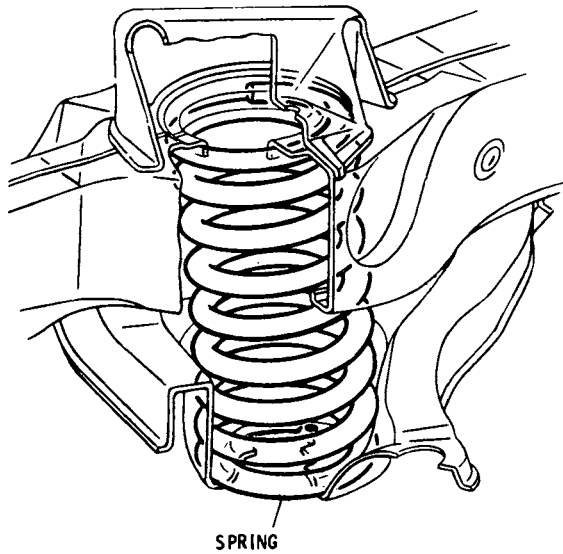

Figure 3B-31 - A Series Steering Knuckle



SPRING

END OF SPRING COIL MUST COVER ALL OR PART OF ONE HOLE. THE OTHER HOLE MUST BE PARTLY EXPOSED OR COMPLETELY UNCOVERED.

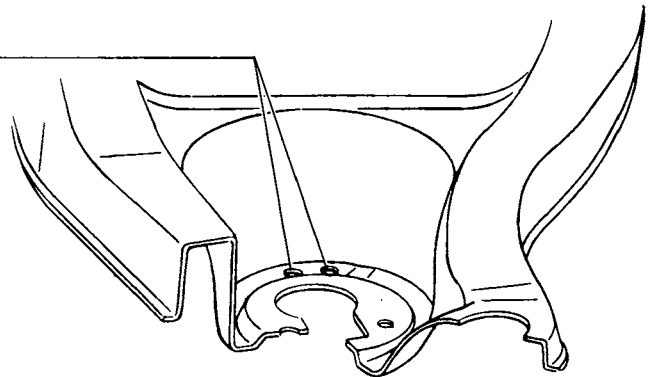
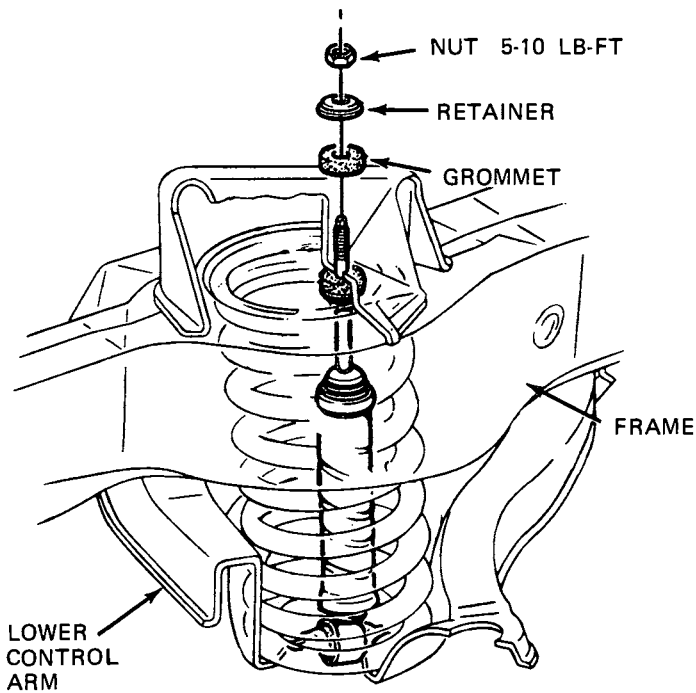

Figure 3B-32 - A Series Spring Placement



NUT 5-10 LB-FT

RETAINER

GROMMET

FRAME

LOWER CONTROL ARM

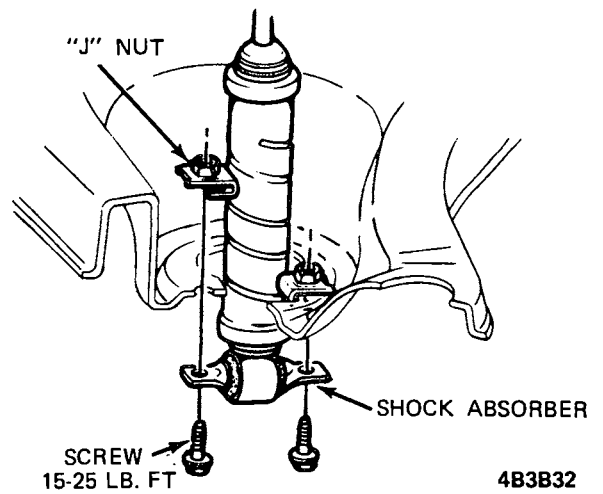

"J" NUT

SHOCK ABSORBER

SCREW 15-25 LB. FT

4B3B32

Figure 3B-33 - A Series Front Shock Absorber

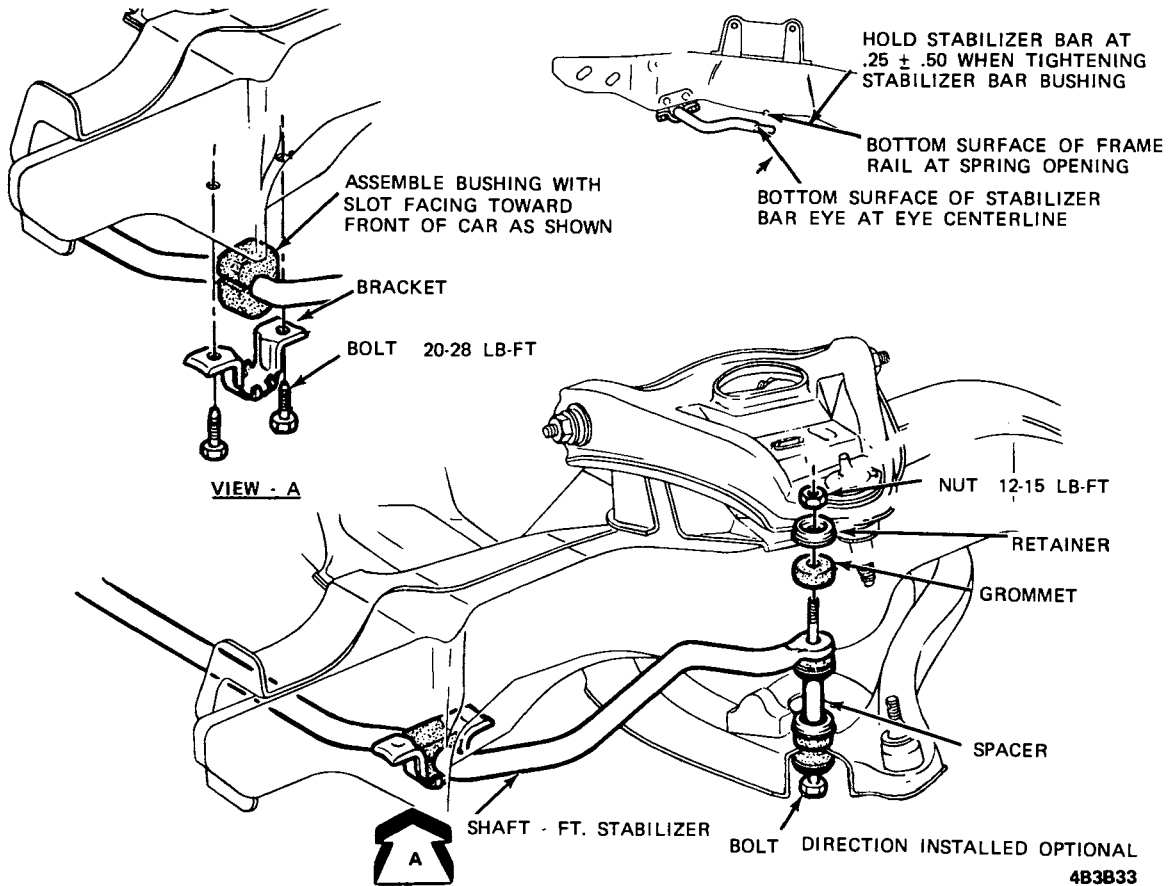

Figure 3B-34 - A Series Front Stabilizer Shaft

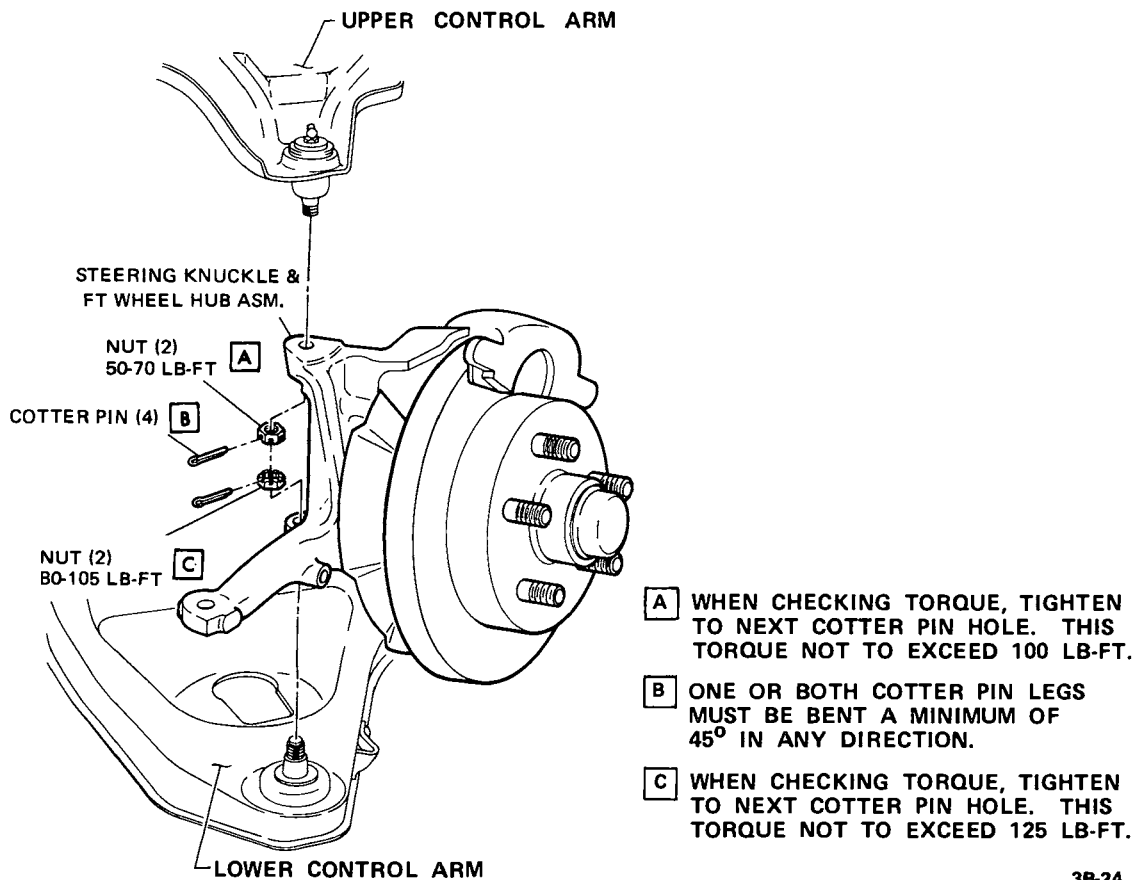

Figure 3B-35 - B-C-E Series Steering Knuckle



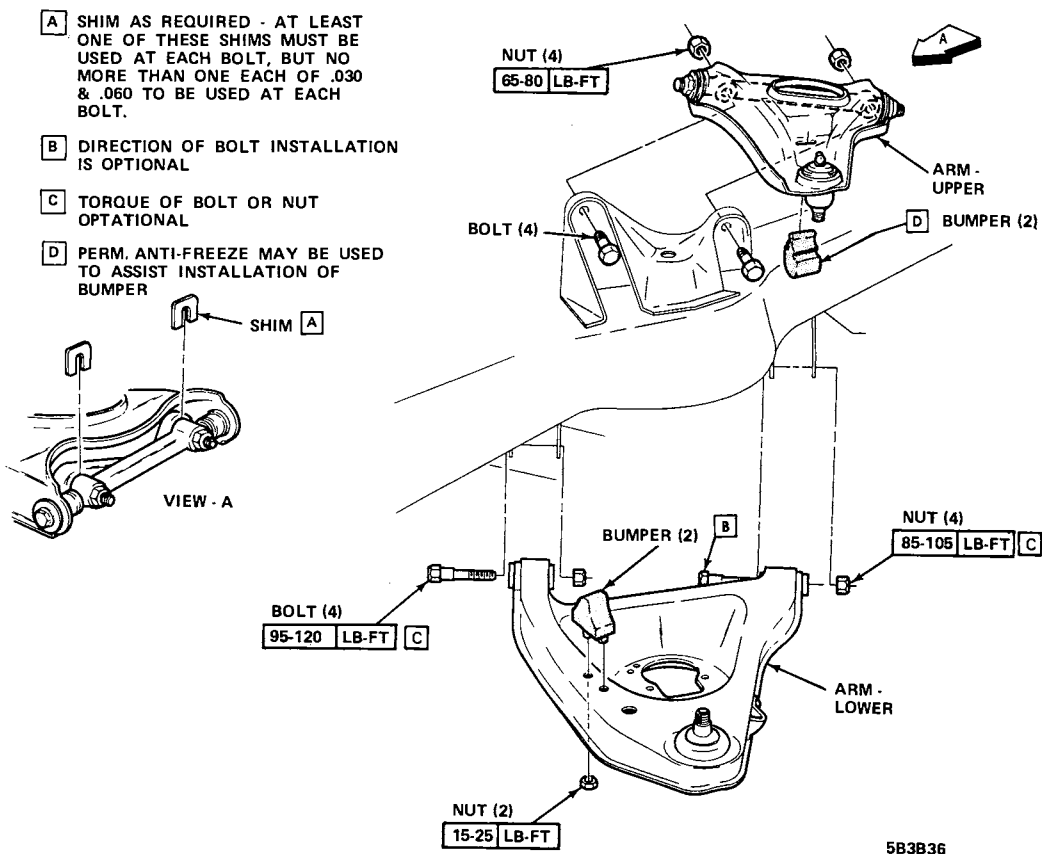

Figure 3B-36 - B-C-E Series Control Arms

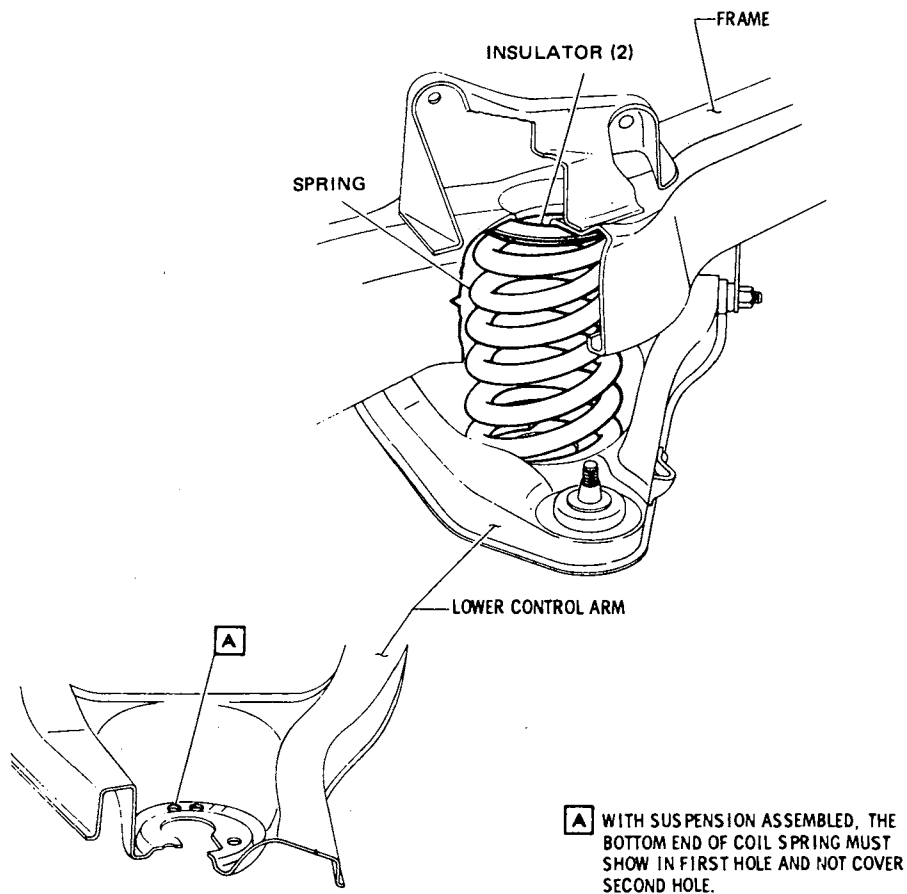

Figure 3B-37 - B-C-E Series Spring Placement

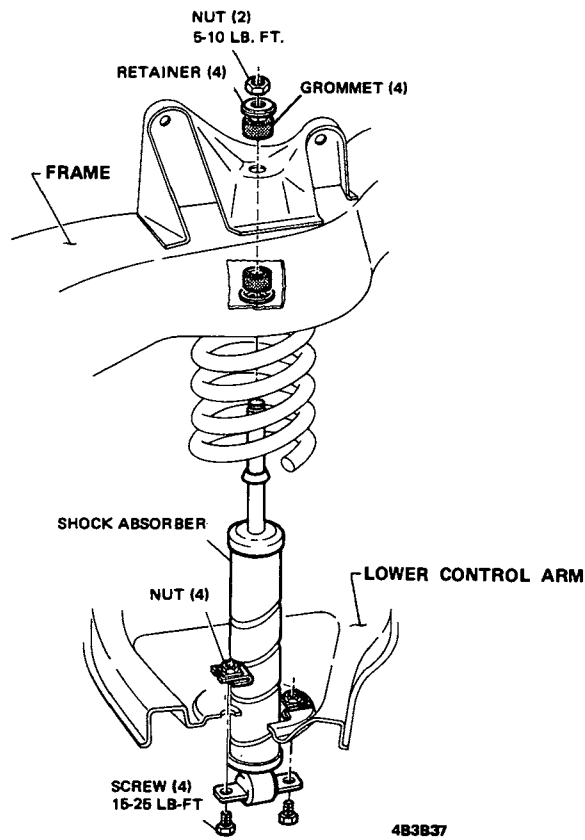

Figure 3B-38 - B-C-E Series Shock Absorbers

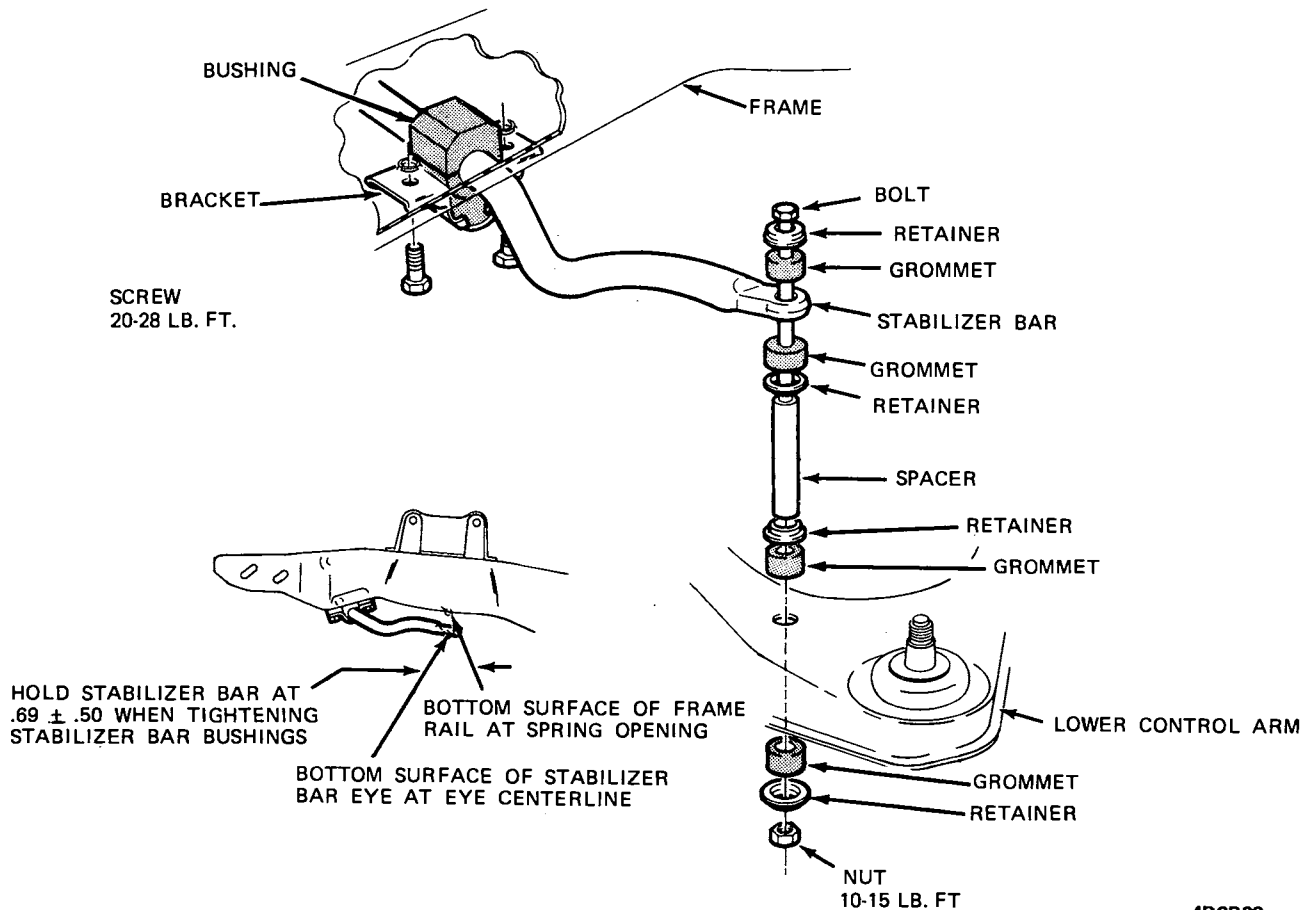

Figure 3B-39 - B-C-E Series Stabilizer Shaft