

# FRAME AND BODY MOUNTS

**WARNING: IF EQUIPPED WITH AIR CUSHION RESTRAINT SYSTEM DO NOT ATTEMPT ANY ADJUSTMENT, REPAIR OR REMOVAL OF THE FRAME SECTION OR COMPONENTS UNTIL THE DISCONNECTION PROCEDURE IS COMPLETED. THIS PROCEDURE MUST BE FOLLOWED TO PREVENT ACCIDENTAL DEPLOYMENT OF THE SYSTEM WHICH COULD RESULT IN PERSONAL INJURY AND/OR DAMAGE TO THE SYSTEMS COMPONENTS. IN ADDITION, CARE MUST BE EXERCISED TO NEVER BUMP OR STRIKE THE BUMPER IMPULSE DETECTOR IN A MANNER WHICH COULD CAUSE INADVERTENT DEPLOYMENT OR IMPROPER OPERATION OF THE SYSTEM.**

**A.C.R.S. DISCONNECTION PROCEDURE**

1. Turn ignition switch to "LOCK" position. Disconnect the negative battery cable from the battery and tape end.
2. If removing or replacing front bumper, remove bolts from bumper impulse detector to bumper impulse detector bracket and tape impulse detector to radiator support until bumper work is completed.

## CONTENTS

<b>DESCRIPTION AND OPERATION:</b>	
Description of Underbody H Series .....	2A-1
Description of Frame and Body Mounts X Series .....	2A-1
Description of Body Mounts A-B-C-E Series .....	2A-2
<b>DIAGNOSIS:</b>	
Diagnosis of Body Mounts .....	2A-2
Diagnosis of Frame .....	2A-2
<b>MAINTENANCE AND ADJUSTMENTS:</b>	
Underbody Inspection .....	2A-2
Frame Inspection.....	2A-2
Underbody Flush.....	2A-2
<b>MAJOR REPAIR:</b>	
H Series Front Crossmember Braces Removal and Installation.....	2A-2
Frame Alignment .....	2A-2
Replacing Body Mounts .....	2A-3
<b>SPECIFICATIONS:</b>	
Frame and Body Mount Specifications .....	2A-3

### DESCRIPTION AND OPERATION

#### DESCRIPTION OF UNDERBODY-H SERIES

The H Series uses a unitized type frame construction. Integral front and rear frame side rails support the bolt-on front end sheet metal, front and rear suspension systems, and other mechanical components.

The transmission crossmember, front crossmember and braces are the only removable parts of the underbody. Figures 2A-1 and 2A-2. Refer to the Major Repair of this section for the procedures.

Unitized construction demands that the underbody components be properly aligned to ensure correct suspension location. In the event of collision damage it is important that the underbody be thoroughly checked and if necessary, realigned back to specifications as covered in the 1975 Body Service Manual.

#### DESCRIPTION OF FRAME AND BODY MOUNTS - X SERIES

The Frame used on the X Series consists of a half frame and half unibody construction. A partial frame supports the front end sheet metal, front suspension, engine and other components. See Figure 2A-3. The rear section of the frame is an integral part of the body.

Six body mounts are used on the partial frame (3 each side). Proper mount usage, location and bolt torque are important. Refer to Figure 2A-4 and 2A-5 for mount locations.

Unitized construction demands that the underbody components be properly aligned to ensure correct suspension location. In the event of collision damage it is important that the underbody be thoroughly checked and, if necessary, realigned back to specifications.

that repairs might be required before the final cleaning and protective treatment is performed.

## DESCRIPTION OF BODY MOUNTS A-B-C-E SERIES

The body of the car is mounted to the chassis by means of thick rubber mounts. These mounts are specifically designed for each location to give the maximum amount of structure strength while at the same time providing maximum road noise isolation. Two different mounts are used for this purpose. At those locations where a bolt is used, the mounting consists of a load carrying mount which rests on top of the frame side rails or mounting brackets, a metal tube spacer which limits the amount of compression of the mount and an insulator which fits on the bottom side of the frame side rail surface. All bolt-in body mounts have a specified bolting torque.

The second type of body mount used is of a plug-in design and has no mounting bolt. This mount plugs into a mounting hole on top of the frame side rail or rear spring seat and acts as a steady rest for the body.

## DIAGNOSIS

### DIAGNOSIS OF BODY MOUNTS

Improper body mount installations may result in the following problems:

1. Structure shake.
2. Road noise.
3. Squeaks.

The above problems can sometimes be caused by the wrong part being installed or the mount not being properly torqued.

If a problem has been *diagnosed* as a body mount problem, two checks can be made to identify the problem. A color code check of the mounts to determine correct usage or a body bolt torque check can be used. If the wrong mount is used, it must be replaced with the correct mount.

### DIAGNOSIS OF FRAME

For H and X Body, Refer to the 1975 Body Manual for frame details. To determine the extent of frame damage resulting from a collision on A-B-C-E Series, a dimension illustration chart in Figures 2A-6, 2A-7, 2A-8, 2A-9 should be used. Any good frame measuring equipment can be used in the actual measuring of the frame.

To bring a frame back into factory specifications, any reputable frame straightening equipment can be used. The procedures with the equipment should be used. Care should be taken to prevent damage to body and frame attachments (steering column, brake lines, etc.).

## MAINTENANCE AND ADJUSTMENTS

### UNDERBODY INSPECTION

Raise the vehicle on a hoist (preferably a twin-post type). Check for obvious floor pan deterioration.

Check for loose dirt and rust around the inside of the floor pan reinforcement member access holes. This is the first indication that corrosion may exist in hidden areas, and

Using a chisel, ensure that the drain provisions in the floor pan reinforcement members are open.

There are drain holes in the body side panels also. These holes can be opened by using a punch or drift. The side panel drain holes are in the rear section of the rocker panels, and in the lower rear quarter panels.

### FRAME INSPECTION

Raise the vehicle on a hoist (preferably a twin-post type). Check for obvious floor pan deterioration.

Check for loose dirt and rust around the inside of the frame rails, on top and at the ends where corrosion may exist in hidden areas. Check especially in the frame box sections for accumulation of debris.

### UNDERBODY FLUSH

Due to the accumulation of road salts and corrosives on the underbody of the car, it is recommended that the entire underbody (suspension, exhaust, brake and gas line areas, etc.) be flushed with clean water each spring. **THIS WILL ADD TO THE LIFE AND STRENGTH OF THE UNDERBODY COMPONENTS.**

## MAJOR REPAIR

### H SERIES FRONT CROSSMEMBER R & R

#### Removal

1. Raise vehicle on hoist.
2. Using jack stands, remove weight of the engine from the body as much as possible without disconnecting engine attachments.
3. Detach right and left braces from the front crossmember only. Figure 2A-1.
4. Disconnect the four bolts connecting the crossmember to the shock towers and remove crossmember. Figure 2A-2.

#### Installation

1. Position new front crossmember to the right side and install two bolts.
2. Mark and drill the left front side hole in the crossmember, install the bolt.
3. Install the left rear bolt through the elongated crossmember hole. Tighten securely.

**CAUTION:** *Torque all bolts and screw assemblies at 35 ft. lbs. Do not over torque.*

4. Remove jack stands.
5. Lower vehicle and remove from hoist.

### FRAME ALIGNMENT

Vehicles involved in an accident of any nature which might result in a "swayed", "splayed", or "sprung" frame should always be checked for proper frame alignment in addition to steering geometry and wheel alignment.

Preparing the car for the frame alignment check involves the following:

1. Place the car on level surface.
2. The weight of the car should be supported at the wheel locations.
3. A visual damage inspection should be made to eliminate needless measuring. Obviously damaged or misaligned areas can often be located by sight.

### TRAMMING SEQUENCE

When checking a frame for alignment in case of damage, the first step is horizontal "X" checking with a tram from similar given points on opposite side of the frame.

Frame alignment checks on all models should be made with the tram points set at the center of each locating point indicated and the cross bar level to insure accuracy. See Figures 2A-6, 2A-7, 2A-8, 2A-9 for frame dimensions on A-B-C-E series.

When "X" checking any section of the frame, the measurements should agree within 5/16". If they do not, it means that frame distortion should be checked to determine if any corrections will have to be made.

If a tram gauge is not available, the "plumb bob" method of checking may be used. To assure any degree of accuracy when using this method, the vehicle should be on a level floor.

By using this method, it is only necessary to have a piece of cord attached to an ordinary surveyor's plumb bob. When measuring the distance between two points, the free end of the cord should be placed on the reference point allowing the plumb bob to hang on the floor. A check mark should be made on the floor just under the tip of the plumb bob. This operation should be repeated at all reference points. With these points located on the floor, they may easily be measured with a rule.

The second step is checking the vertical dimensions from the datum plane to the points to be trammed. With the proper settings, the tram bar will be on a plane parallel to

that of the frame. The exception to this would be when one of the reference locations is included in the misaligned area; then the paralleled plane between the frame and the tram bar may not prevail. After completion of the repairs, the tram gauge should be set at the specified dimension to check the accuracy of the repair operation.

### REPLACING BODY MOUNTS

The removal of any one body mount necessitates the loosening of adjacent body mountings to permit the frame to be separated from the body.

Front bumper, rear bumper, and radiator cross rods must be loosened before replacing body mounts.

During installation of a body mount, caution should be used to insure that the body mount is properly seated in the frame mounting hole, otherwise a direct metal to metal ground will result between the frame and body. Care should also be taken to prevent damage to body and frame attachments such as steering column, brake pipes, etc. The tube spacer should be in all bolt-in body mounts and the insulator and metal washer positioned to prevent the washer from contacting the frame side rail. Do not use lubricants of any kind on the rubber parts of the mounts. Proper clamping by the mount depends on clean and dry surfaces. Do not over-torque the body mount or a collapsed tube spacer or stripped bolt may result. Lubricating the bolt threads will result in a higher clamping force for the same torque setting. If the body mount bolt does not screw in smoothly, it may be necessary to run a tap through the cage nut in the body to remove foreign material. If caution is not observed, broken body mount bolts may result. Caution should also be used to insure that tap doesn't punch through underbody.

### SPECIFICATIONS

#### FRAME AND BODY MOUNT SPECIFICATIONS

Refer to the following art for frame and body mount specifications.

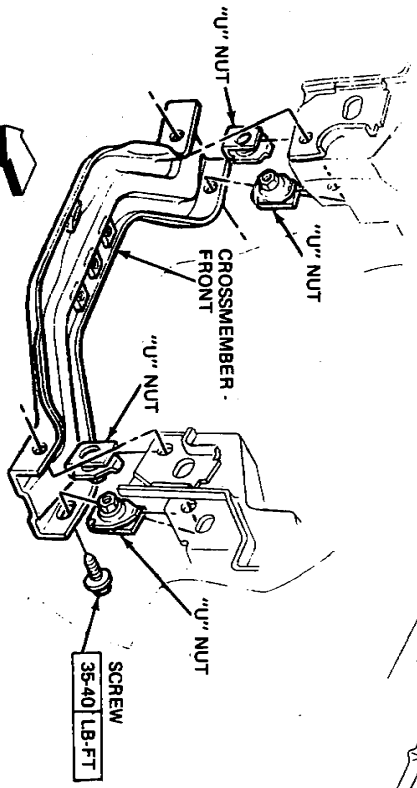
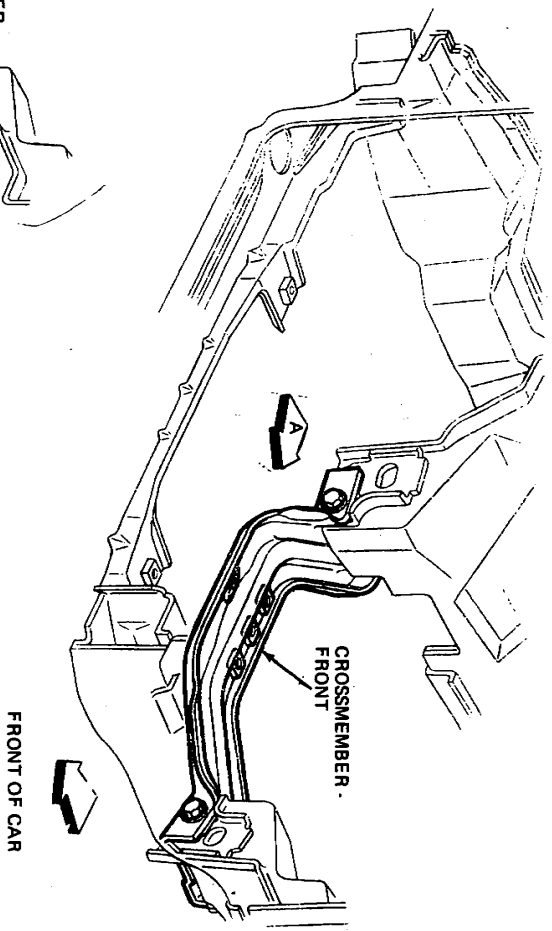

FRONT OF CAR VIEW -A

Figure 2A-1 H Series Front Crossmember

5B2A1

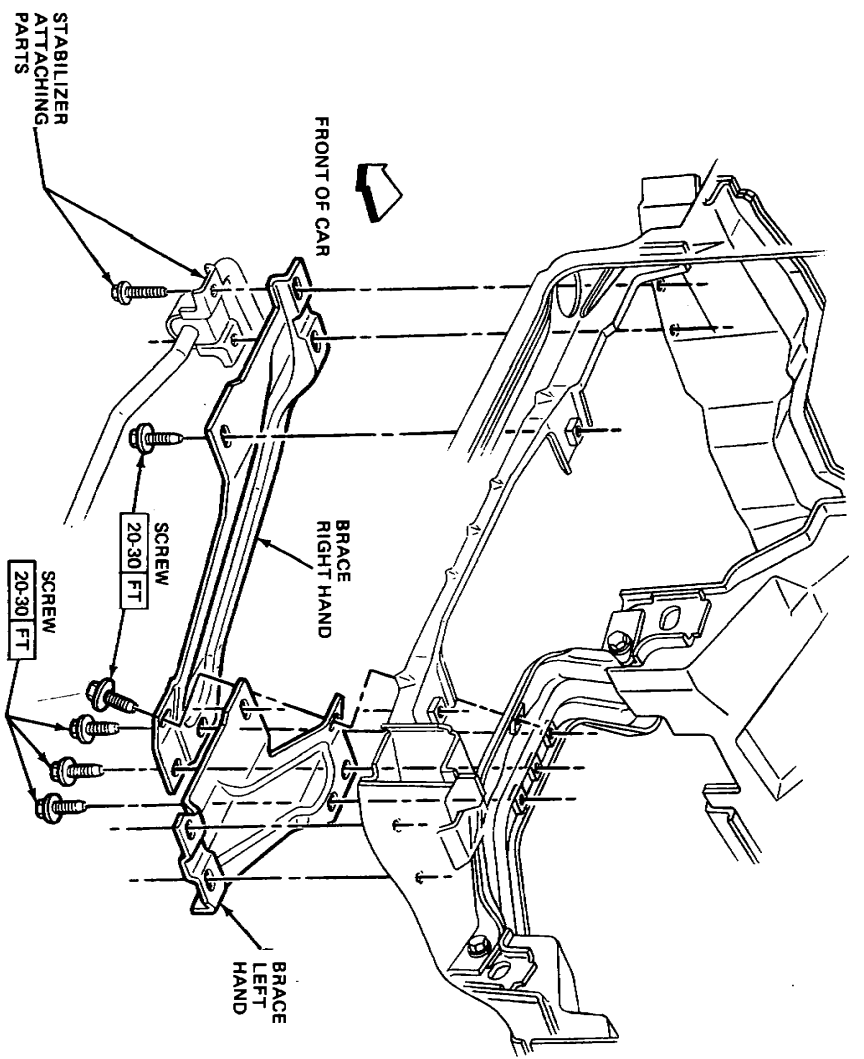
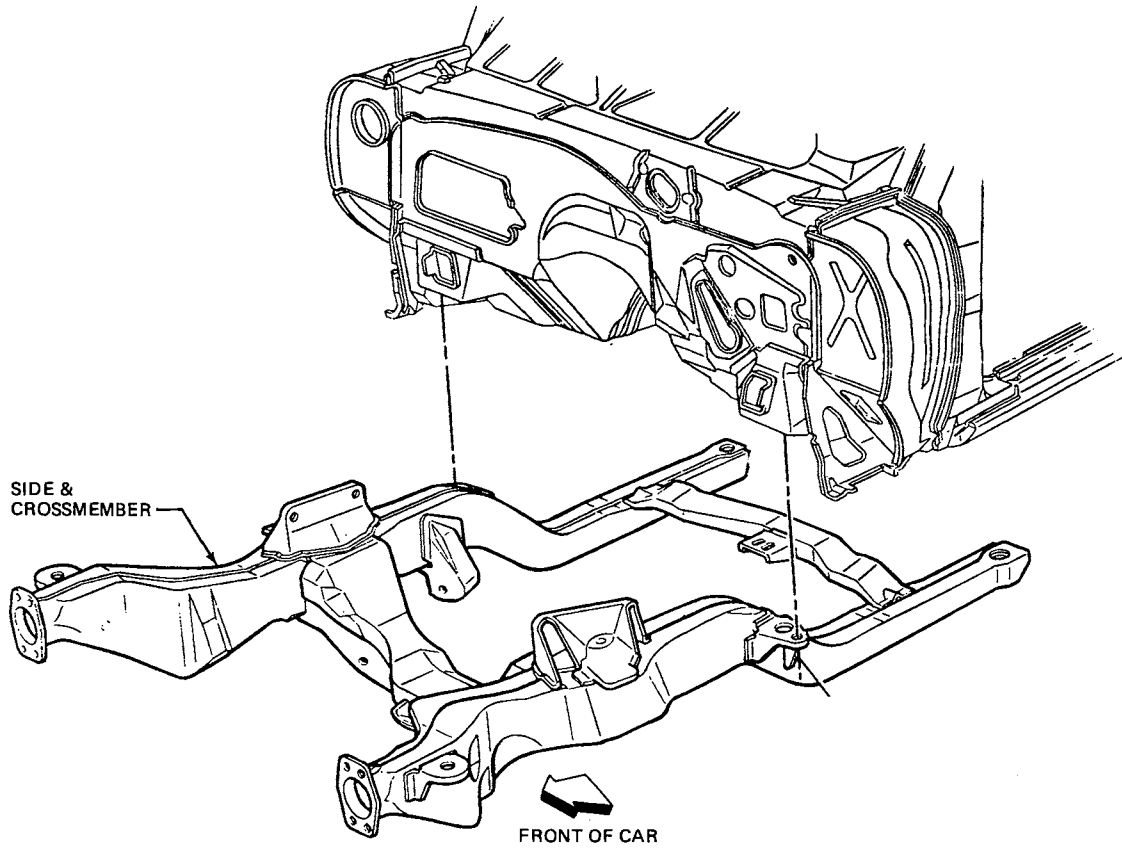

Figure 2A-2 H Series Front Crossmember Braces

5B2A2



5B2A3

Figure 2A-3 X Series Frame

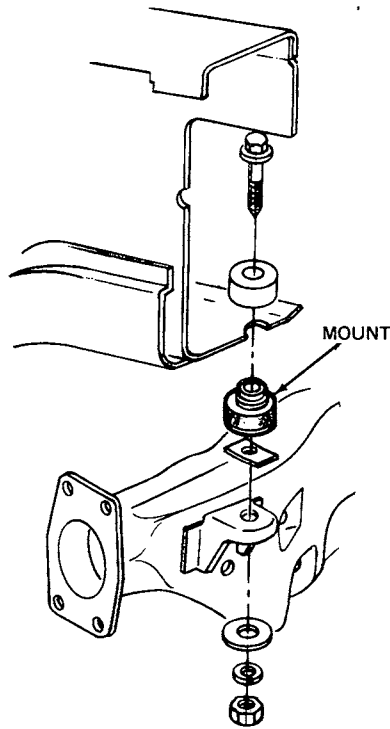

MOUNT NO. 1

5B2A4

Figure 2A-4 X Series Front Sheet Metal Mount

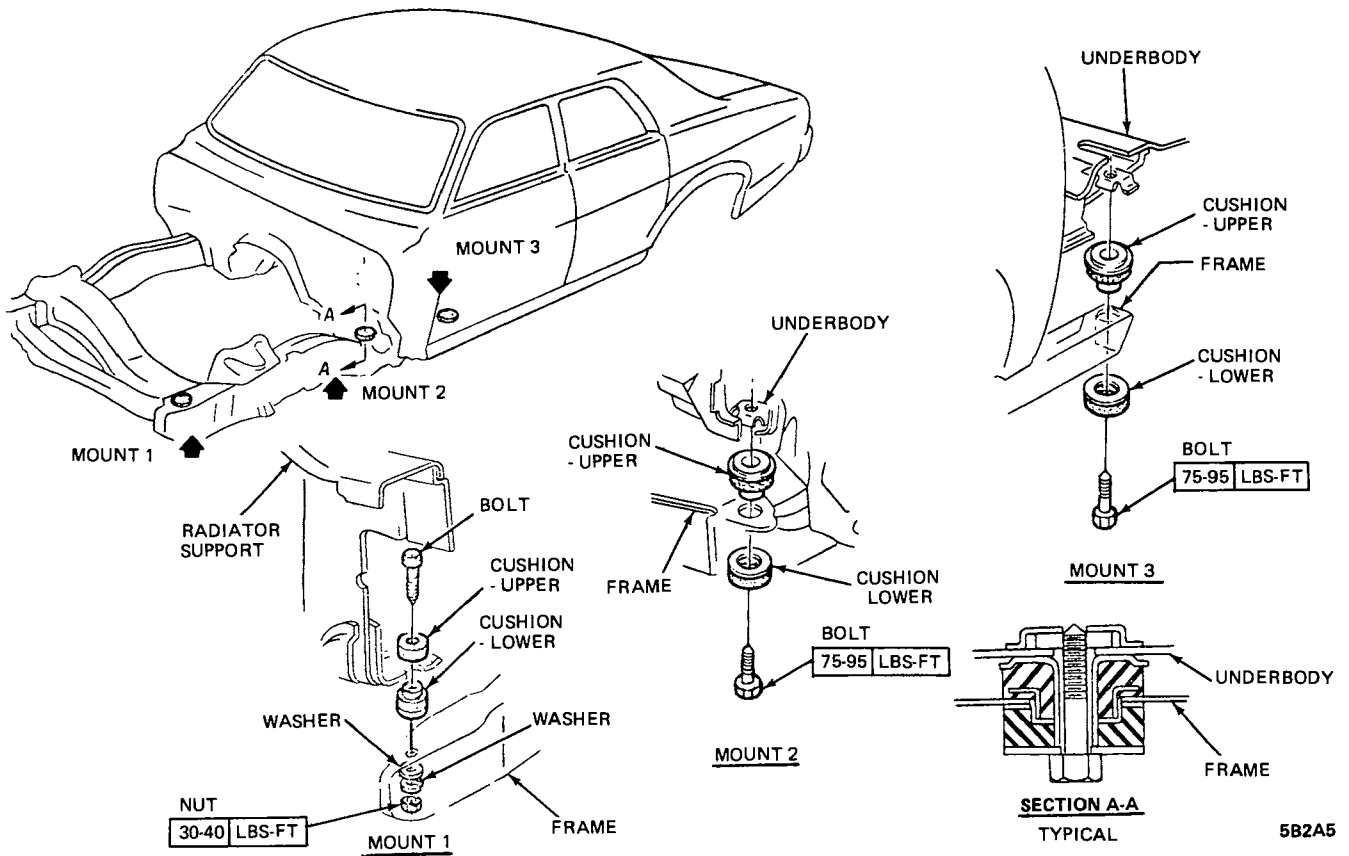
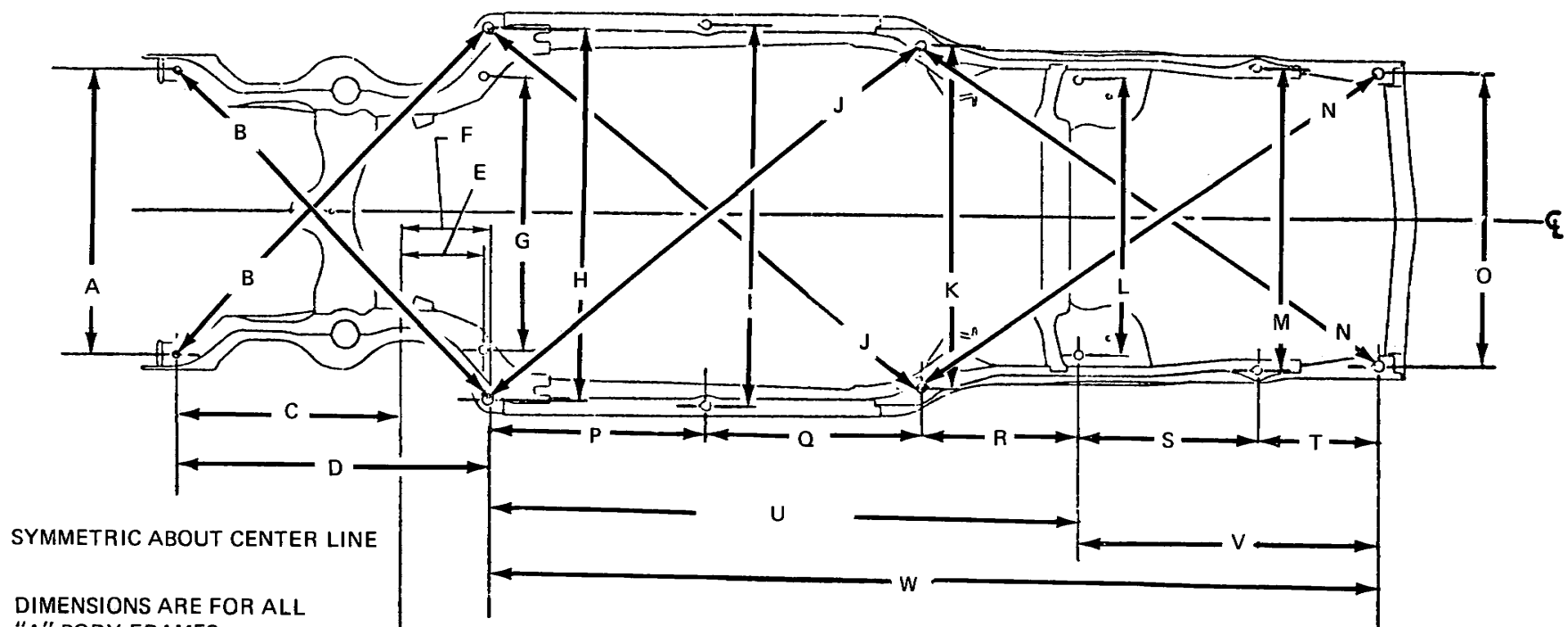

Figure 2A-5 X Series Body Mounts

5B2A5

Figure 2A-6 A Series Frame Details



SYMMETRIC ABOUT CENTER LINE

DIMENSIONS ARE FOR ALL "A" BODY FRAMES UNLESS OTHERWISE INDICATED.

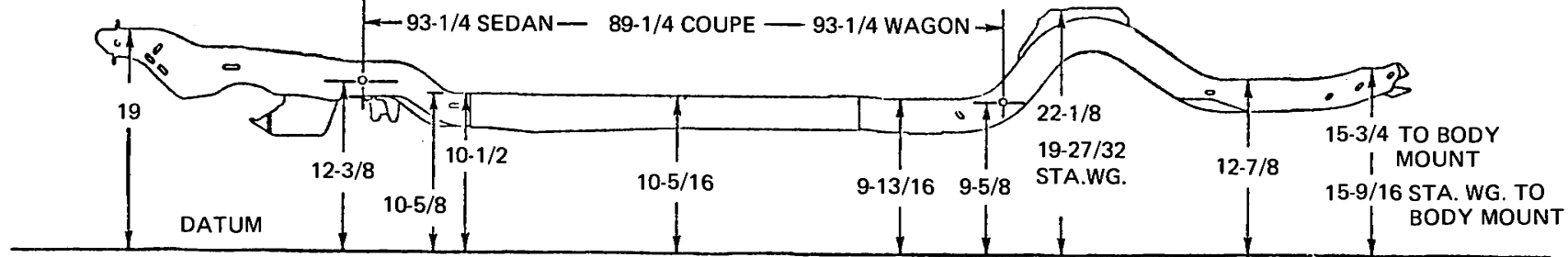

COUPE W.B.—112 IN.  
 SEDAN W.B.—116 IN.  
 STATION WAGON W.B.—116 IN.

R.H. SIDE TO BE WITHIN 1/8 OF L.H.  
 R.H. SIDE TO BE WITHIN 3/16 OF L.H.

5B2A6

## A - SERIES FRAME DIMENSIONS

**NOTE; All dimensions are from centerline to centerline.  
All dimensions in inches.**

DIMENSION	2-DOOR	4-DOOR	STATION WAGON
A	40-3/4	40-3/4	40-3/4
B	64-29/32	64-29/32	64-29/32
C	32-5/32	32-5/32	32-5/32
D	44-29/32	44-29/32	44-29/32
E	12-3/16	12-3/16	12-3/16
F	12-3/4	12-3/4	12-3/4
G	39	39	39
H	53	53	53
I	54-1/2	54-1/2	54-1/2
J	80-21/32	83-25/32	83-25/32
K	49-1/4	49-1/4	49-1/4
L	39-7/16	39-7/16	39-7/16
M	43-5/16	43-5/16	40-9/32
N	79-7/32	79-7/32	84-13/16
O	38	38	34-21/32
P	31-1/2	31-1/2	31-1/2
Q	30-7/8	34-7/8	34-7/8
R	22-21/32	22-21/32	21-3/8
S	25-3/4	25-3/4	27
T	17-23/32	17-23/32	25-5/16
U	85-1/32	89-1/32	87-3/4
V	43-15/32	43-15/32	52-5/16
W	128-1/2	132-1/2	140-1/16

Figure 2A-7 A Series Frame Dimensions



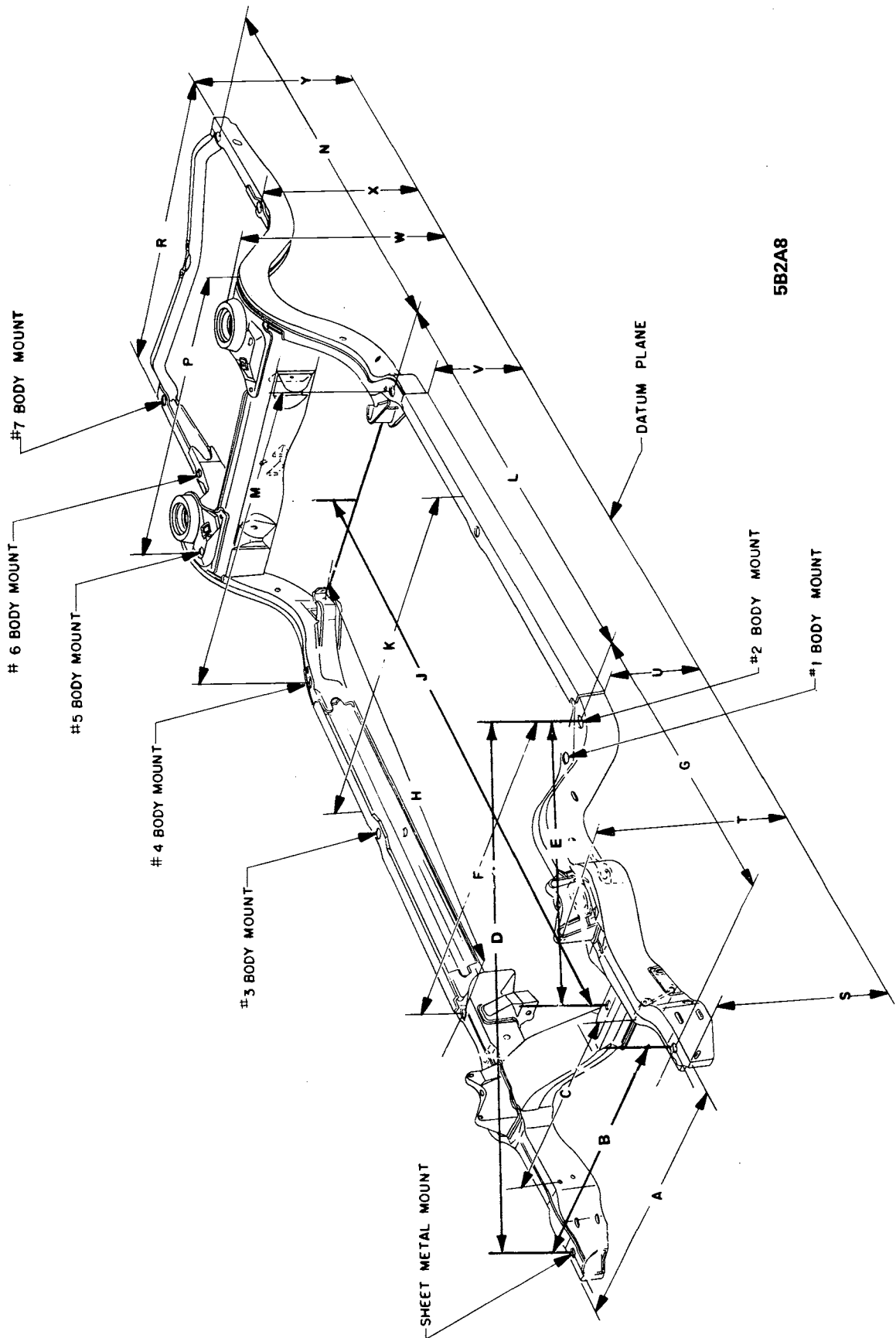
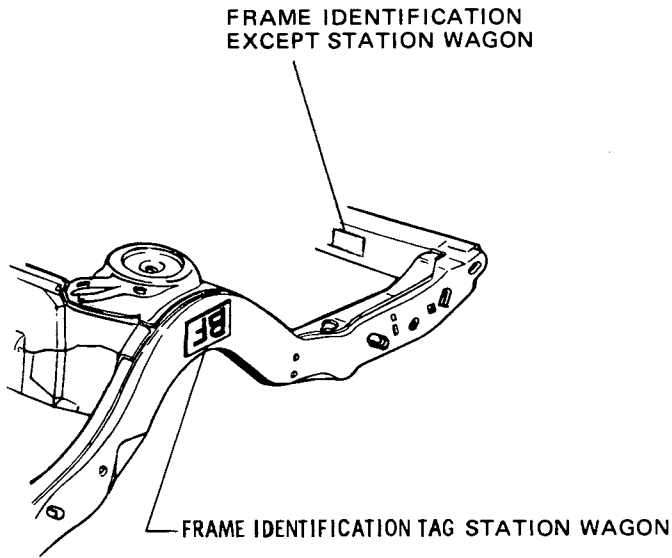

Figure 2A-8 B-C-E Series Frame Details

LeSabre Centurion	Electra	Riviera	Estate Wagon	
A — 42 7/16	42 7/16	42 1/2	42 1/2	Outside edge to outside edge of frame front side rail.
B — 39 1/2	39 1/2	39 1/2	39 1/2	Center to center of sheet metal mount holes.
C — 31 7/8	31 7/8	31 7/8	31 7/8	Center top front steering gear bolt hole to center top hole idler arm mounting.
D — 66 7/16	66 7/16	68 3/16	66 7/16	Center of sheet metal mount hole across to center number 2 body mount hole.
E — 36 5/8	36 5/8	38 5/16	36 5/8	Center gage hole front cross member to center number 2 body mount hole.
F — 55 1/8	55 1/8	55 1/8	55 1/8	Center to center of number 2 body mount holes.
G — 46 5/8	46 5/8	49 1/8	46 5/8	Center sheet metal mount hole to center number 2 body mount hole.
H — 77 3/8	80 5/16	73 7/16	—	Center number 2 body mount hole to center rear lower control arm frame bracket hole.
J — 100 29/32	104 13/32	100 1/16	—	Center gage hole front cross member to center rear lower control arm frame bracket hole.
K — 59 11/16	59 3/4	59 11/16	59 11/16	Outside edge to outside edge of frame center side rail.
L — 68 9/16	72 1/16	64 9/16	70 5/32	Center number 2 body mount hole to center number 4 body mount hole.
M — 54 5/16	54 5/16	54 5/16	55 1/4	Center to center of number 4 body mount holes.
N — 72 9/32	72 9/32	67 11/16	67 11/32	Center of number 4 body mount hole to center number 7 body mount hole.
P — 51 1/8	51 1/8	51 1/8	49 1/4	Outside edge to outside edge of frame at rear spring seat.
R — 54 29/32	54 29/32	54 29/32	47 9/16	Outside edge to outside edge of frame at rear corner.
S — 15 3/8	15 13/32	15 3/8	15 7/16	Top of front of frame to datum plane.
T — 19 7/16	19 7/16	19 7/16	19 7/16	Center front upper control arm frame bracket front hole to datum plane.
U&V — 5	5	5	5	Locations for mounting number 2 and 3 datum gages.
W — 23 5/8	23 11/16	23 5/8	—	Bottom surface rear spring seat to datum plane.
X — 12 15/16	12 31/32	12 15/16	14 31/32	Top of frame at number 6 body mount to datum plane.
Y — 13 5/16	13 11/32	13 5/16	12 21/32	Top of rear of frame to datum plane.

5B2A9

Figure 2A-9 B-C-E Series Frame Dimensions



C H A R T		
CODE	SERIES	BODY STYLE
XW	AD-AH-AJ	29
XU	AD-AH-AJ	37-57
XX	AF-AK	35
BF	BN-BP	39-69
BC	BN-BP	57
BD	BN-BP WITH POLICE CAR OPT.	39-57-69
BD	BP	67
BH	BR	35-45
BM	CA	39
BR	EA	87
BU	CA	37

5B2A10

Figure 2A-10 A-B-C-E Frame Identification

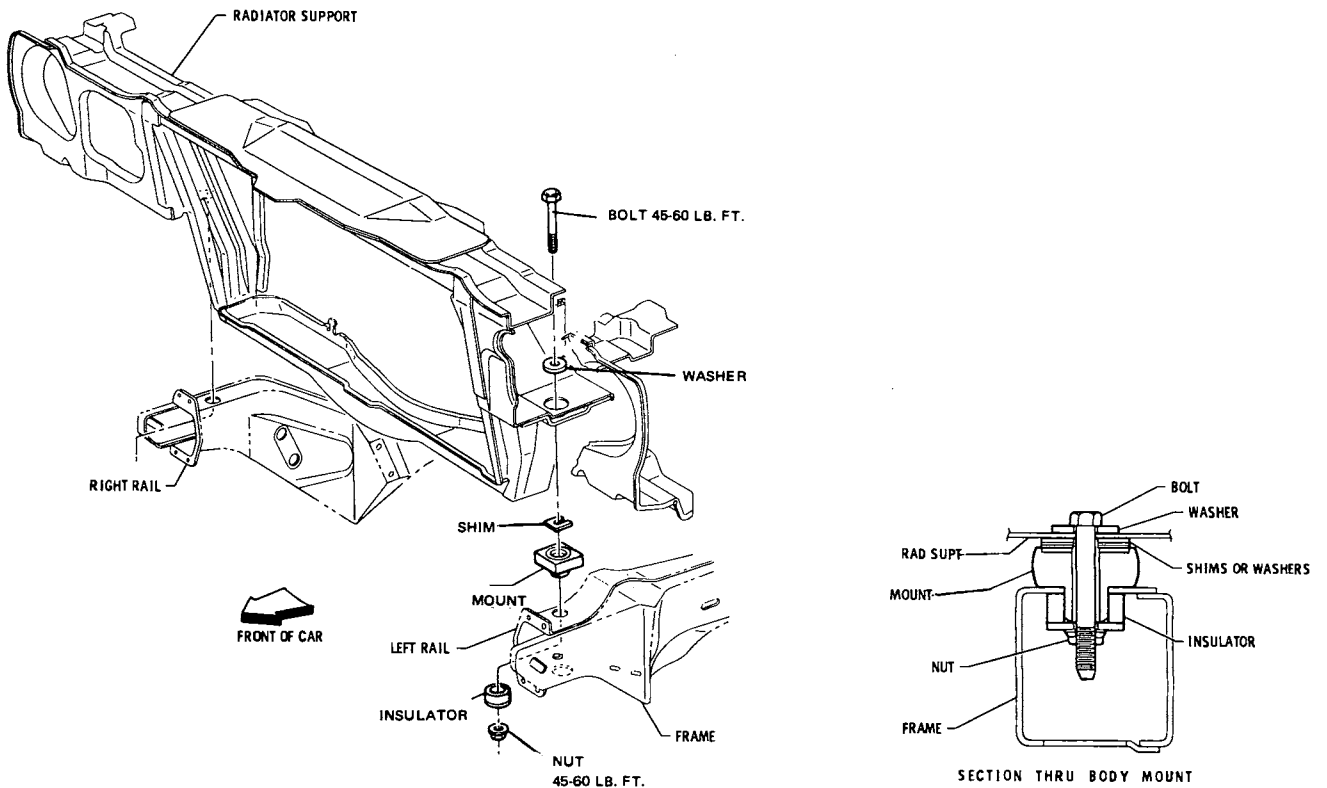

5B2A11

Figure 2A-11 A Series Front Sheet Metal Mount

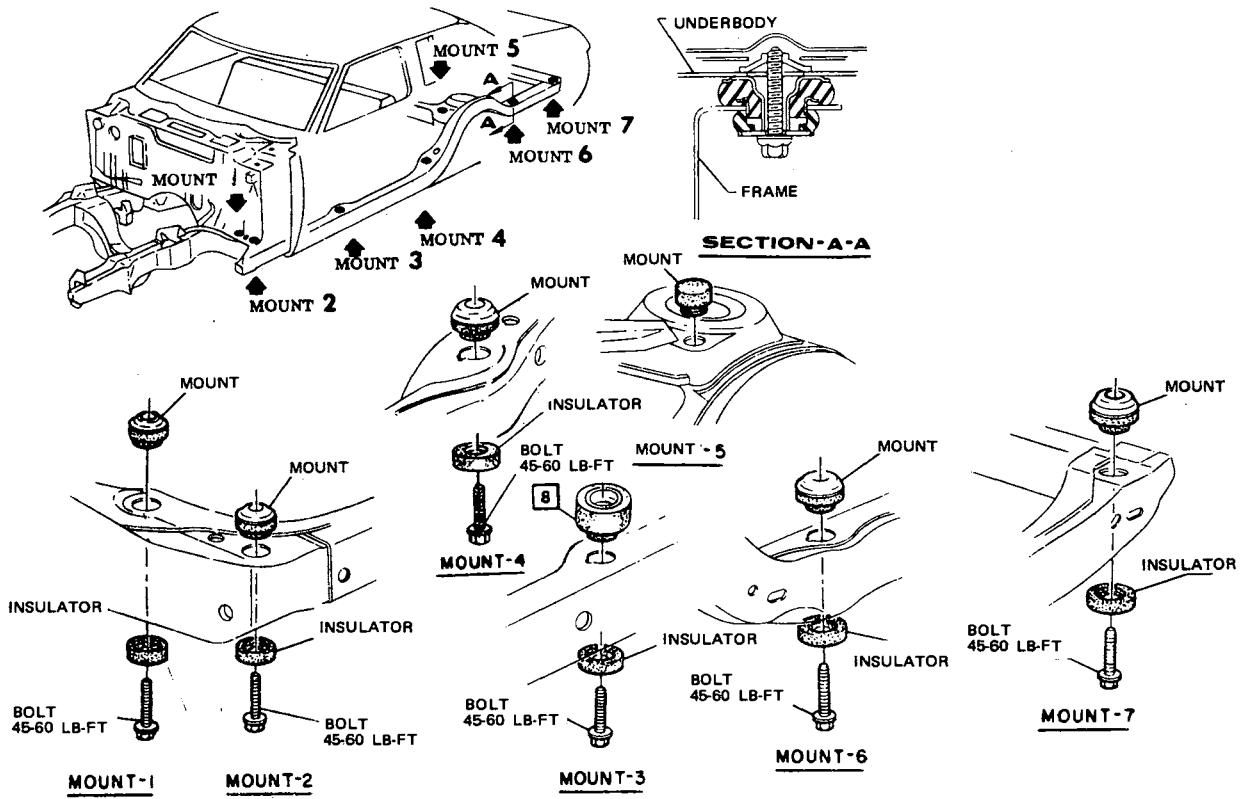

5B2A12

Figure 2A-12 A Series Body Mounts All

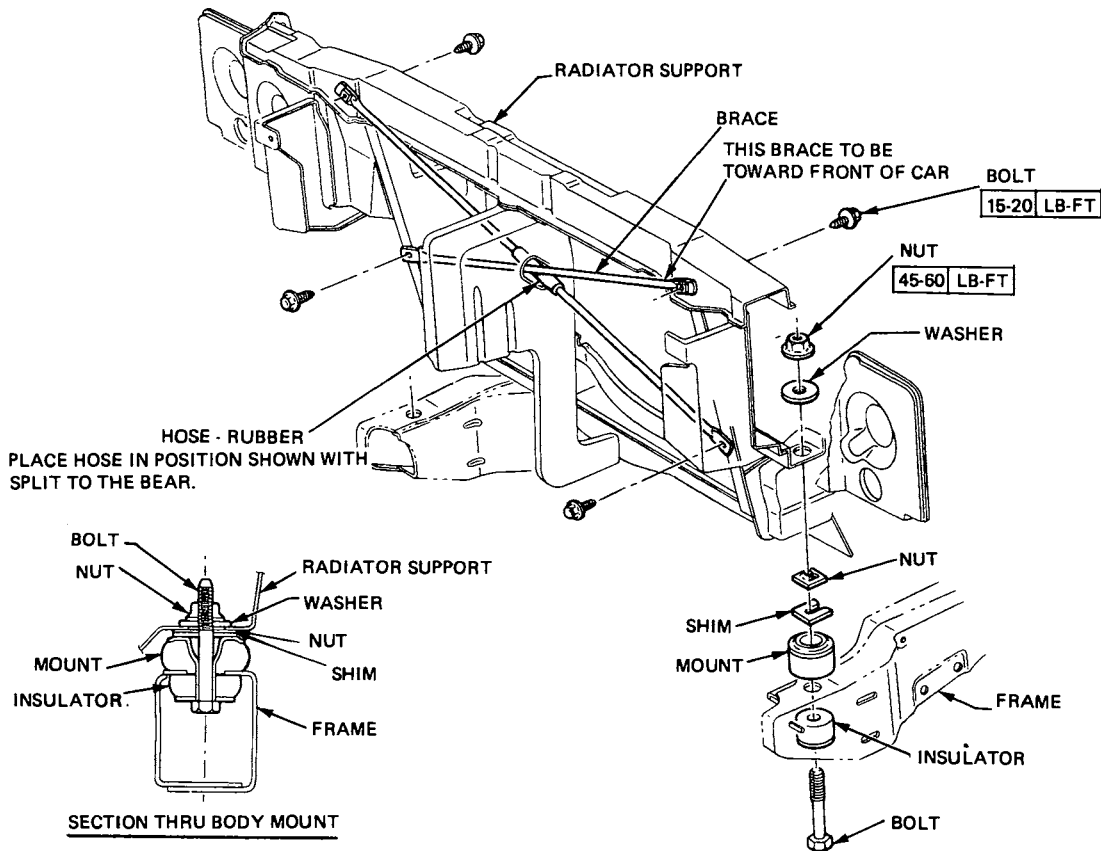

5B2A13

Figure 2A-13 B-C Series Front Sheet Metal Mount

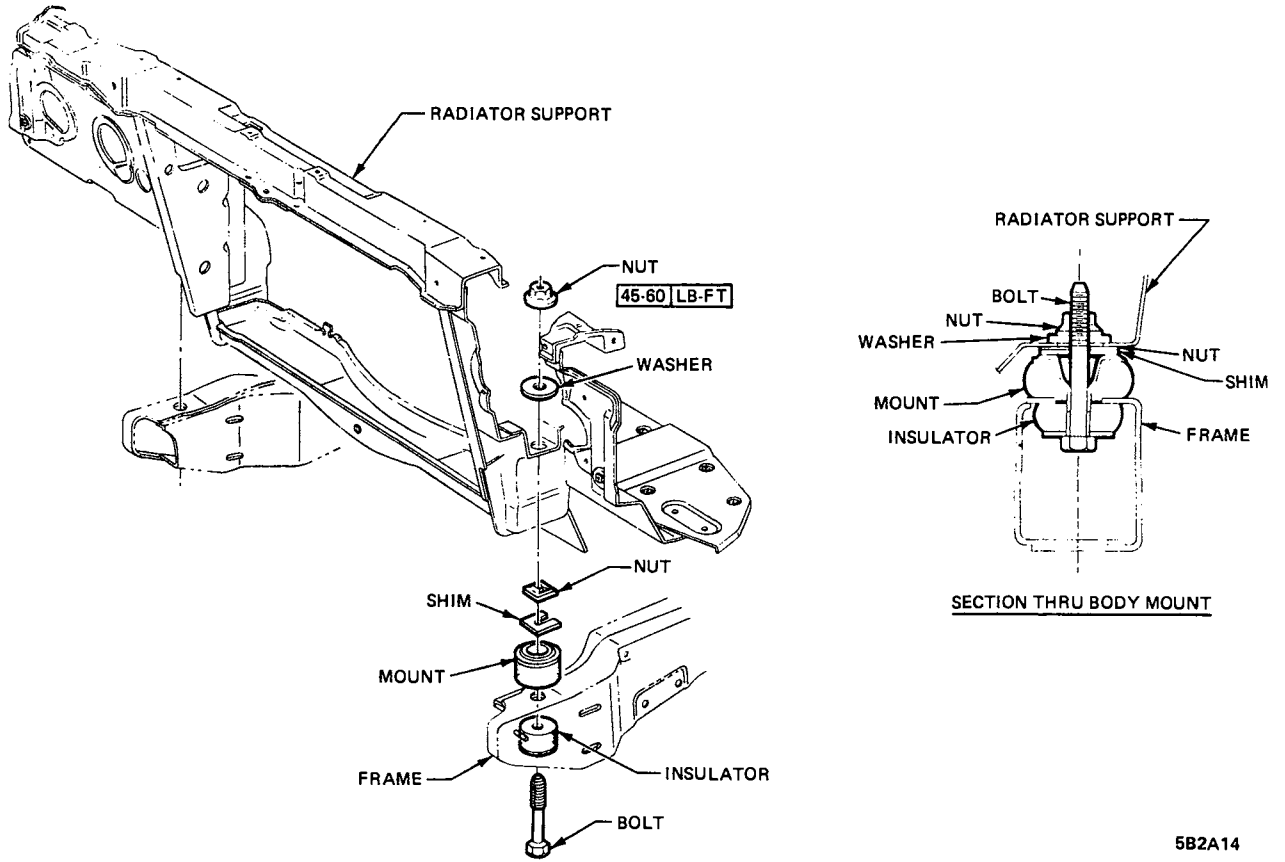

5B2A14

Figure 2A-14 E Series Front Sheet Metal Mount

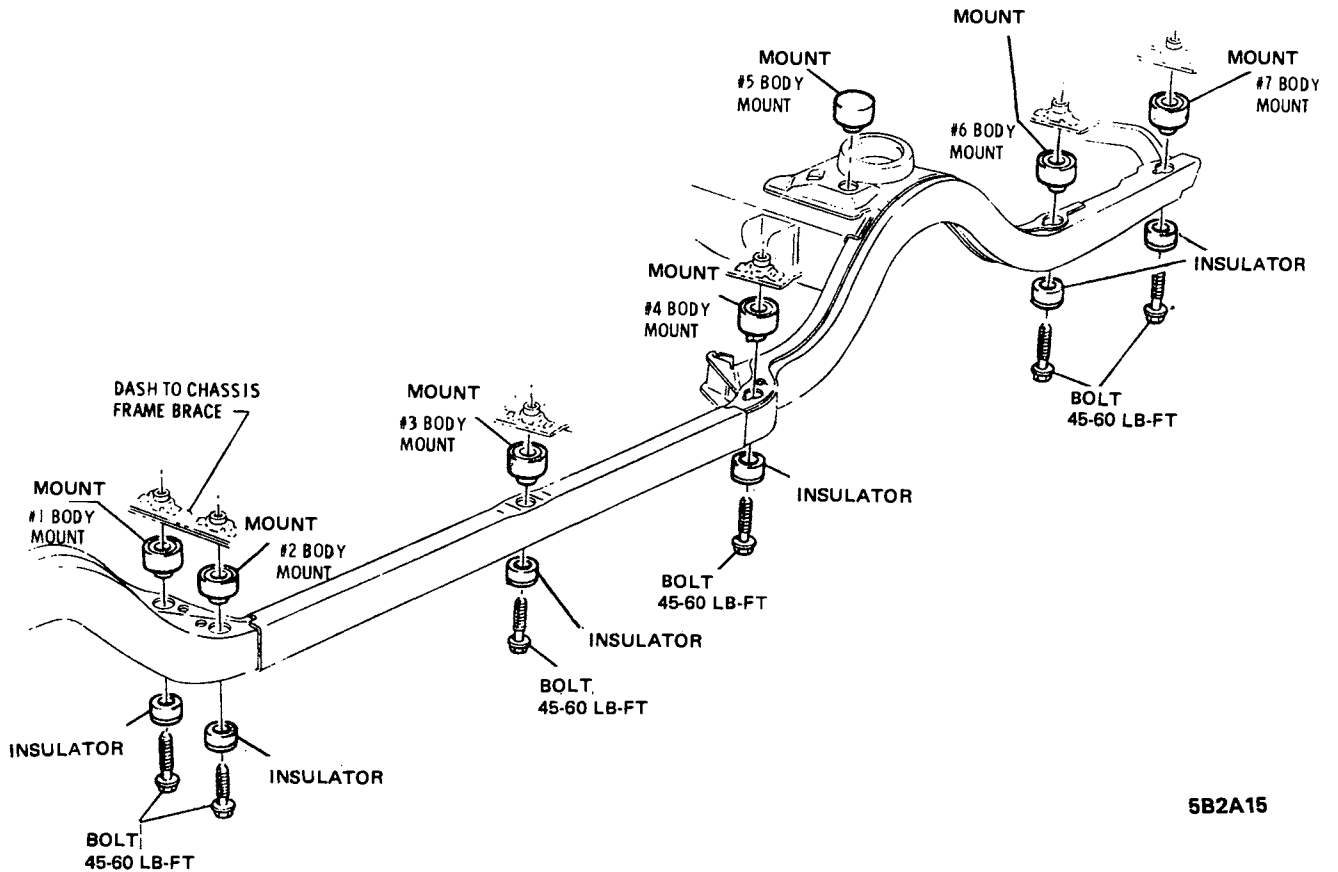

5B2A15

Figure 2A-15 B Series (Less Wagon) Body Mounts

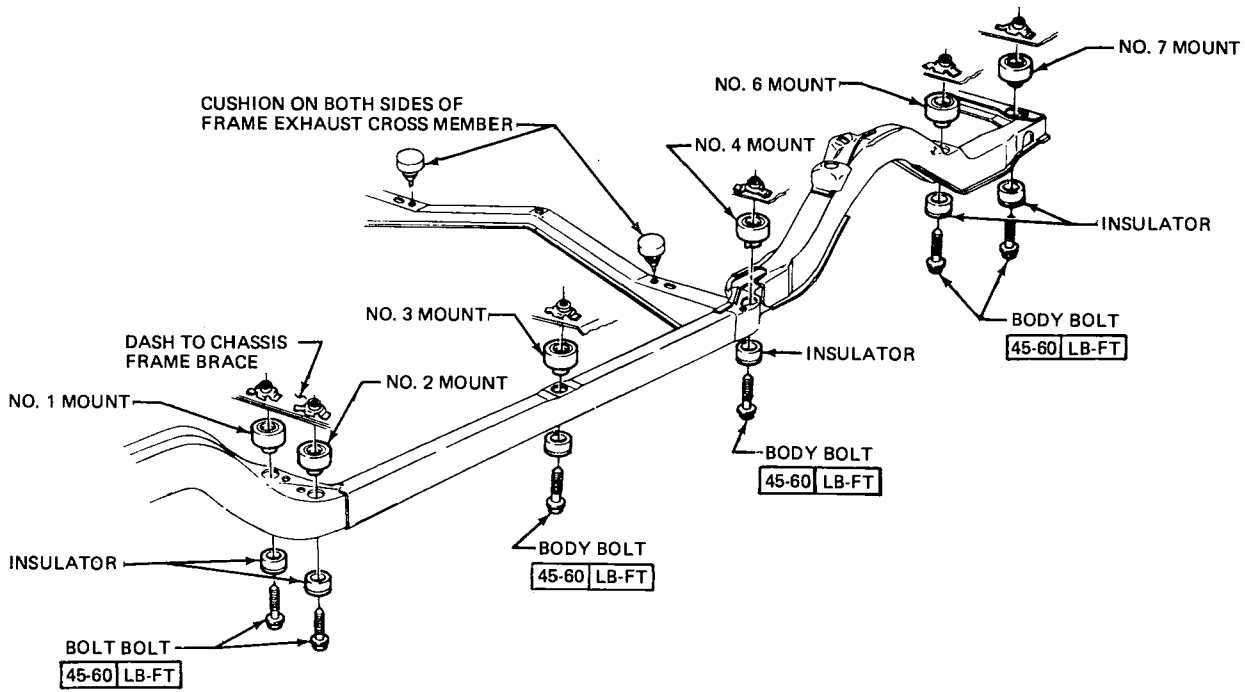

5B2A16

Figure 2A-16 B Series Wagon Body Mounts

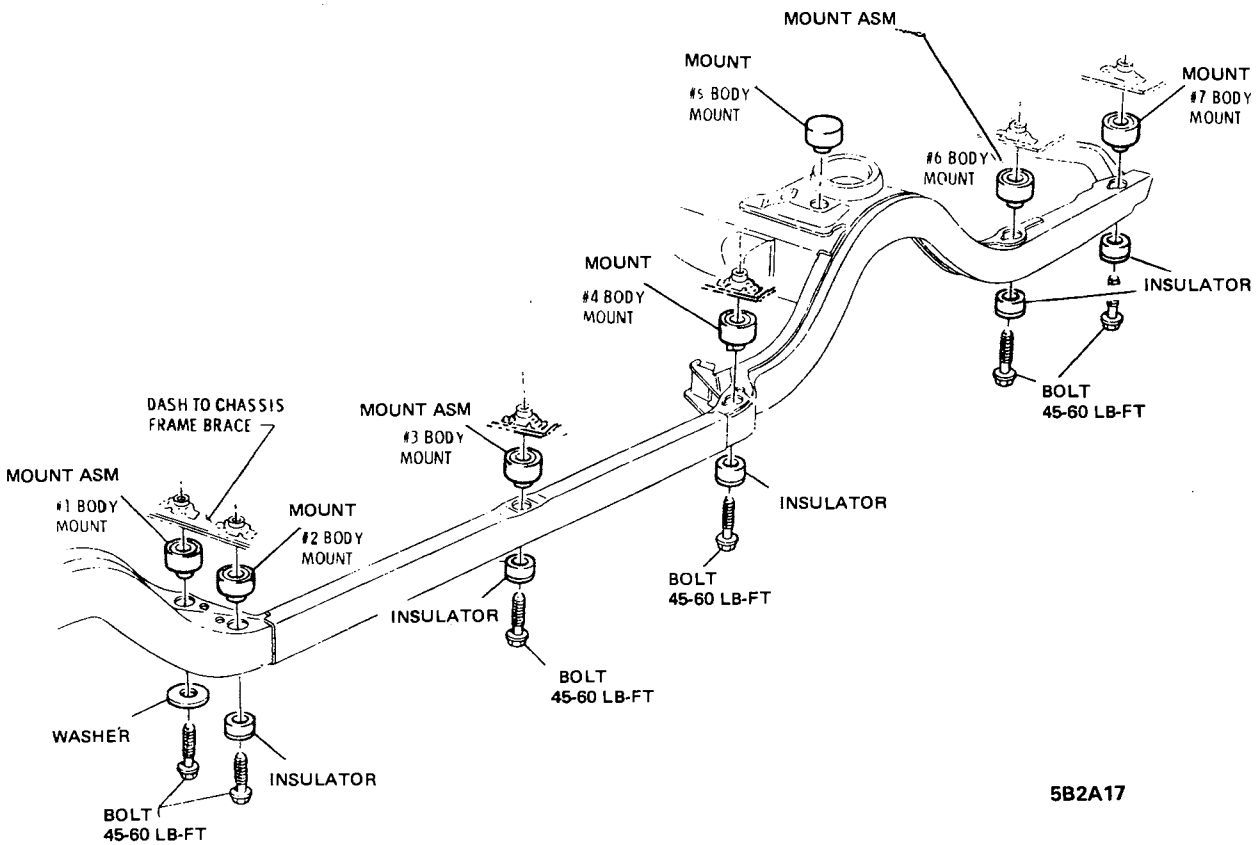

5B2A17

Figure 2A-17 C Series Body Mounts

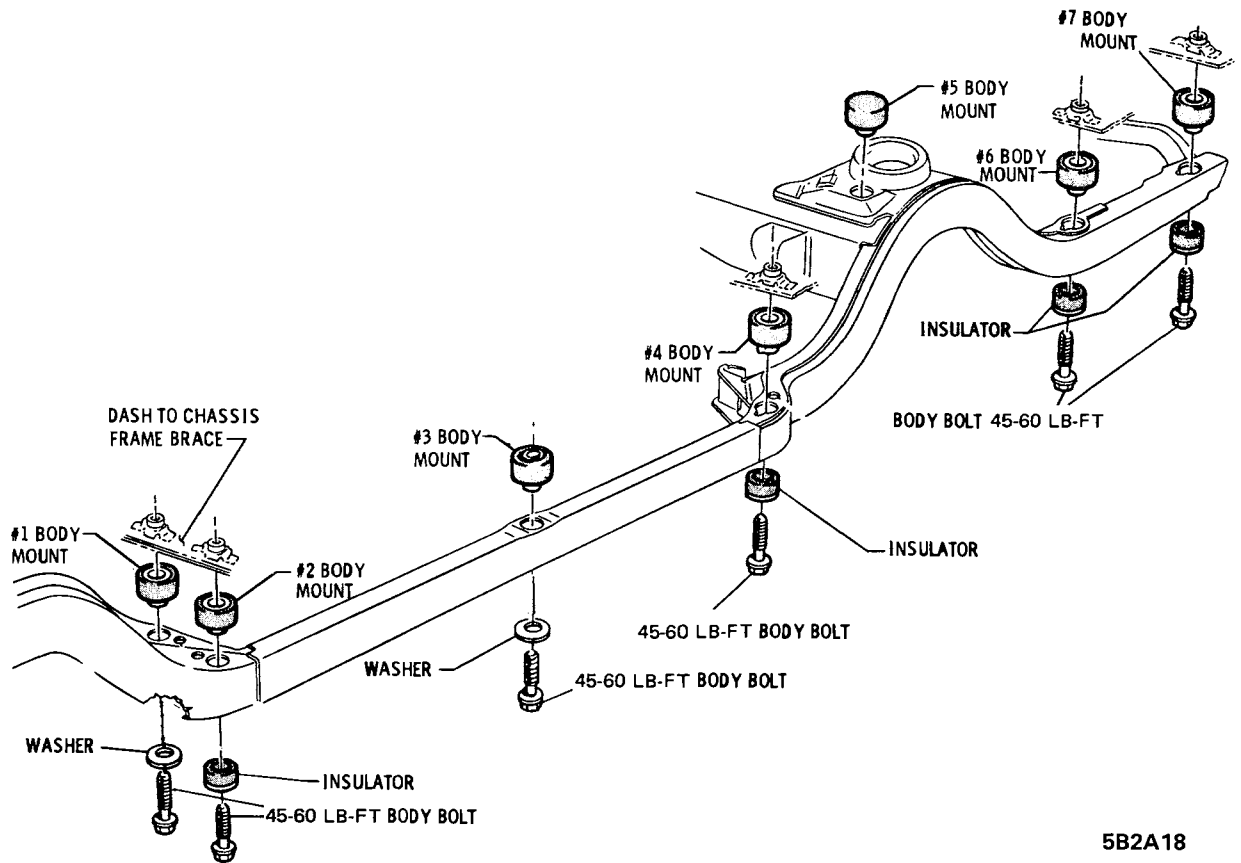

5B2A18

Figure 2A-18 E Series Body Mounts