

GENERAL INFORMATION

ALL SERIES

CONTENTS

DESCRIPTION AND OPERATION: (Not Applicable)
DIAGNOSIS: (Not Applicable)
MAINTENANCE AND ADJUSTMENTS:
 Keys and Locks..... 0A-1
MAJOR REPAIR: (Not Applicable)
SPECIFICATIONS:
 Standard Specifications 0A-5
 Major Component Identification 0A-6

MAINTENANCE AND ADJUSTMENTS

KEYS AND LOCKS

For 1975, all Buicks will have two types of lock cylinders with the "A" type and "B" type keyway, the same as used on the 1971 model Buicks.

All ignition locks have the "A" type keyway. All door, glove tailgate compartment and rear compartment lock cylinders have the "B" type keyway.

The ignition lock key has a rectangular head. The markings on the head of the key will be the same as 1971. head of the key will be the same as 1970. The key identification "A" will be located on the shank just below the coining on the head. In addition, a code number will be stamped on the knockout portion of the key head and will have indicia from any one of the series 00V0 to 99V9 and 00W0 to 99W9. These numbers identify the locks combination and are used when ordering or making new keys by code.

The door, rear compartment and glove compartment lock keys will have door, oval heads. The markings on the head will be similar to the 1975 square key. The capital letter "B" will be stamped on the shank just below the coining on the head. In addition, a code number will be stamped on the knockout portion of the key head and will have indicia from any one of the series 00G0 to 99X9 and 00Y0 to 99Y9. These numbers identify the locks combination and are used when ordering or coding new keys by code.

Keys used for Buick locks in 1972, 1973 and 1974 will not enter either of the "A" or "B" keyways, nor will the 1975 keys enter keyways meeting Buick specifications used in the above listed years.

The 1975 lock series codes will have 2000 different key combinations with new code numbers. Five biting depths will be continued.

Cutting Keys

After the special code has been determined, either from the code list or the Key Code Diagram, cut a blank key to the proper level for each of the six tumbler positions,

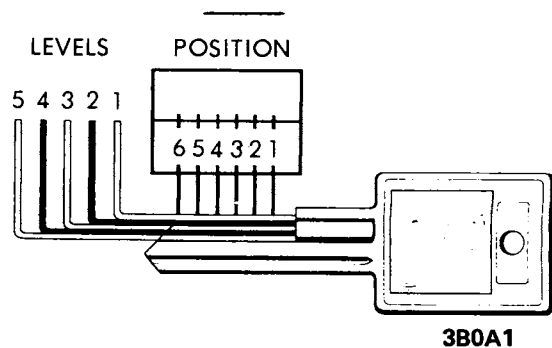

Figure 0A-1 - Key Code Diagram

and check the key in the lock cylinder. The new key should agree with the combination opposite the code number in the code list.

Removal and Installation of the Ignition Lock

Remove and install the ignition lock assembly from the steering column following the procedures outlined in Group 3.

Selecting Lock Cylinder Tumblers

The 1975 factory-installed ignition lock is not serviceable. Should failure require service, a new ignition lock package is available from the Parts Department less tumblers. Tumblers are also available and must be installed into the ignition lock cylinder according to the following special code.

When it is necessary to code a new lock cylinder to agree with a key code number, install the proper tumblers into their respective slots, as indicated by Key Code Diagram or Briggs and Stratton Code List.

Tumblers for all locks except the glove and console compartments are shaped exactly alike, with the exception of the position of a notch on one side. Tumblers for glove and console lock cylinders are different and will not interchange with any other lock tumblers. As the key is inserted in the lock cylinder, the tumblers are raised to the

correct height so that the notches on each tumbler are on the same level. When the notches on all six tumblers line up, the locking bar is pushed into the notches by two small springs, allowing the cylinder to turn in its bore. Five types of tumblers are used to make all the various lock tumbler combinations and each is coded according to a number, 1 through 5, stamped on its side.

Only one type of tumbler is used to make the various lock tumbler combinations for glove and console compartment locks. Tumblers for these two lock cylinders are of a different design than the tumblers used in all other lock cylinders.

As the key is inserted in the lock cylinder, each tumbler is depressed so that no part of any tumbler is exposed above the level of the lock cylinder allowing the cylinder to turn in its bores.

To determine which tumblers should be installed in what position for a given key, when a code list is not available, proceed as follows:

1. Lay the key on the Key Code Diagram, Figure 0A-1, with the key outlined by the diagram as accurately as possible.
2. Starting at the base of the key blade, determine the lowest level that is visible in position No. 1.
3. Determine the lowest visible level for the remaining five positions. As each tumbler level is determined, write that number in the blank space provided above the position numbers.
4. Cuts that fall in the first white section, mark Level No. 1 on top of appropriate position number.
5. Cuts that fall in the first black section, mark No. 2 on top of appropriate position number.
6. Cuts that fall in the second white section, mark No. 3 on top of appropriate position number.
7. Cuts that fall in the second black section, mark No. 4 on top of appropriate position number.
8. Cuts that fall in the third white section, mark No. 5 on top of appropriate position number.

**Installing Lock Cylinder Tumblers
(Except Glove and Console Compartments)**

After the tumbler arrangement has been determined as shown, ignition and door lock cylinders should be assembled as follows:

1. Hold cylinder with head of cylinder away and starting at the head of the cylinder, insert the tumblers in their proper slots in the order called for by the code, ribbed side toward you and long point down. See Figure 0A-2.
2. Insert one tumbler spring in the space provided above each tumbler. If the springs become tangled, do not pull them apart - unscrew them.
3. Reverse the lock cylinder so that the head of the cylinder is now toward you. Insert the spring retainer so that the two end prongs slide into the slots at either end of the cylinder. Press the retainer down. See Figure 0A-3.

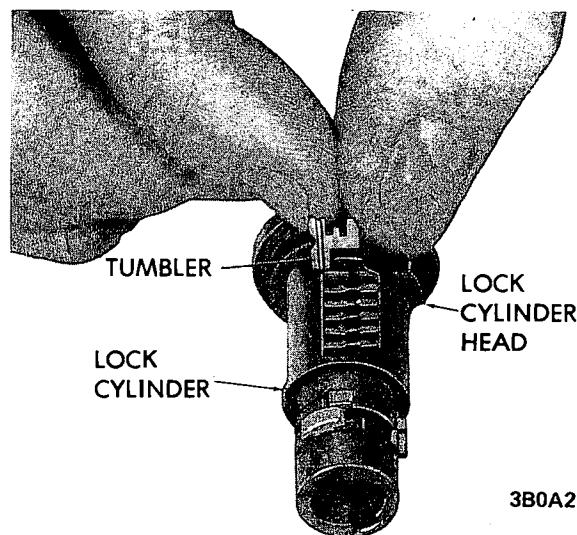

Figure 0A-2 - Installing Tumblers

4. To check, insert proper key and if tumblers are installed properly the side bar will be allowed to drop down. If bar does not drop down, remove the key, spring retainer, springs and tumblers and reassemble correctly.

If the tumblers have not been assembled correctly, they can be removed from the cylinder by holding it with the tumbler slots down, pulling the locking bar out with the fingers and jarring the cylinder to shake the tumblers out.

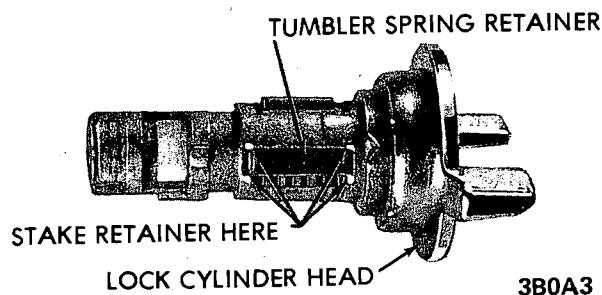

Figure 0A-3 - Installing Spring Retainer

This procedure is necessary because once the tumblers have been pressed down into the cylinder they are held in their slots by the side bar.

5. If after checking, it is found that the lock is assembled properly, remove key and secure cylinder in a vise with spring retainer exposed. Use leather or wood at each vise jaw to prevent damage to the cylinder.
6. Stake the retainer securely in place by staking the cylinder metal over both edges at each retainer end using a suitable staking tool at right angles to the top of the retainer.

Assembling Service Ignition Locks

1. Place the key part way into the lock cylinder assembly. Place the wave washer and anti-theft ring onto the lower end of the lock cylinder.

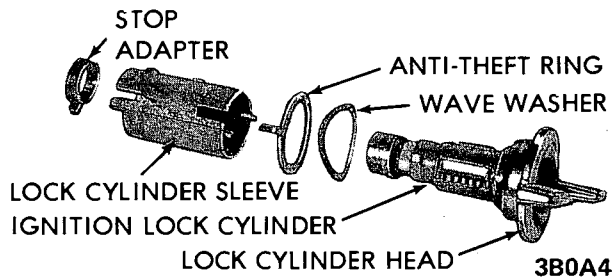

Figure OA-4 Ignition Lock Assembly - Exploded View

If the key is installed all the way into the lock cylinder, the plastic keeper in the lock cylinder protrudes and prevents installation of the sleeve assembly.

2. Make sure that the plastic keeper in the sleeve assembly protrudes from the sleeve.
3. Align the lock bolt on the lock cylinder and the tab on the anti-theft washer with the slot in the sleeve assembly. Push the sleeve all the way onto the lock cylinder assembly, push the ignition key the rest of the way in and rotate the lock cylinder clockwise. See Figure OA-5.

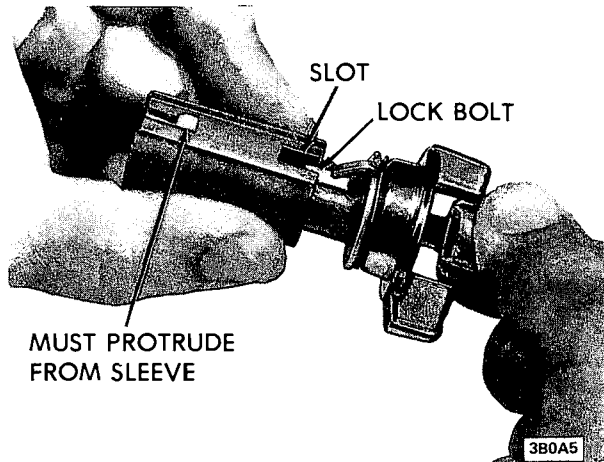

Figure OA-5 Ignition Lock - Assembly

4. Place assembled ignition lock assembly into vise with wood blocks to protect finish. Place stop adapter on lock cylinder with stop positioned down. See Figure OA-6.
5. Using a hammer and a small pin punch, stake lock cylinder at four (4) places to retain stop adapter. Do not use force when striking cylinder, as metal is soft and only a light tap with a hammer is necessary. See Figure OA-7.

Assembling Glove and Console Compartment Lock Cylinders

These two lock assemblies are equipped with four or five tumblers rather than six required in other locks. Tumblers for positions 3-4-5-6 or 2-3-4-5-6 only. Do not install tumblers which correspond to positions 1 and 2 on the key. The non-brass "tumbler" that is closest to the head of the lock cylinder is a locking device and must not be removed unless damaged.



Figure OA-6 Installing Stop Adapter on Lock Cylinder

1. Insert properly coded key in position.
2. Place cylinder in a vise using leather or wood at each vise jaw to prevent damage to the cylinder.
3. File tumblers down so that no part of any tumbler extends above the lock cylinder. A standard 5/8" double

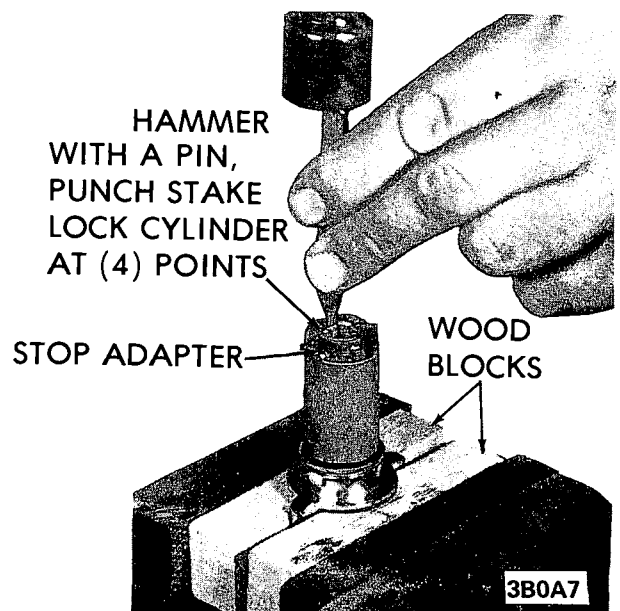

Figure OA-7 Staking Lock Cylinder to Retain Lock Adapter

cut bastard file is recommended for this operation. To finish the job, use a flat 5-1/2" No. 2 cut needle equaling file. Do not file any part of black "tumbler" in position No. 2. This is a locking bar and should not be altered.

4. Reverse lock cylinder position in vice and repeat Step 5 for bottom of tumblers. See Figure 0A-7.

COLOR NAME	SALES CODE	SERVICE CODE	SERIES
WHITE	C	11	A-B-C-E-H-X
SILVER METALLIC	D	13	A-B-C-E-X
LIGHT GRAYSTONE	B	15	A-B-C-X
MEDIUM GRAYSTONE METALLIC	I	16	H
GRAY METALLIC	E	1B	E
BLACK	A	19	A-B-C-E
SILVER BLUE METALLIC	O	21	E-H
MEDIUM BLUE	G	24	A-B-C-X
BRIGHT BLUE METALLIC	H	26	A-B-C-E-H-X
DARK BLUE METALLIC	J	29	A-B-C-E-X
MEDIUM GREEN	K	44	A-B-C-E-X
DARK GREEN METALLIC	L	49	A-B-C-E-H-X
CREAM BEIGE	M	50	A-B-C-E-H-X
BRIGHT YELLOW	N	51	H-X
SANDSTONE	P	55	A-B-C-E-X
BRIGHT GOLD METALLIC	Q	57	E
DARK SANDSTONE METALLIC	S	58	E-X
DARK BROWN METALLIC	R	59	A-B-C
LIGHT SADDLE METALLIC	T	63	A-B-C-X
PERSIMMON METALLIC	U	64	A-B-C-E-X
RED	V	72	A-B-C-E
RED METALLIC	W	74	A-B-C-E-X
RED	X	75	H-X
BURGANDY METALLIC	Y	79	H
ORANGE METALLIC	Z	80	H

5B0A10

Figure 0A-8 - 1975 Exterior Paint Chart

VEHICLE IDENTIFICATION NUMBER

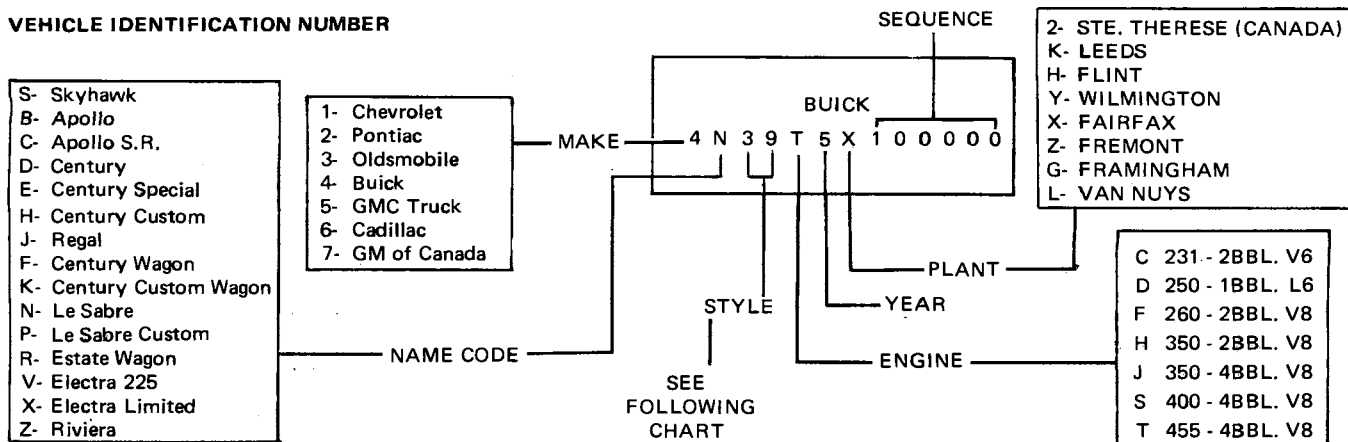

STANDARD SPECIFICATIONS											
SERIES	SALES MODEL NO.	WHEEL-BASE	BODY STYLE	STANDARD			FRONT TREAD	OVERALL			
				ENG.	TRANS	AXLE		LENGTH	HEIGHT	WTH	
H SPL	4HS07	97.0	2-DOOR HATCH BK CPE	231-2 V6	4-SPD. MAN.	2.56	54.6	179.3	50.0	65.4	
X	4XB69	111.0	4-DOOR T/P SEDAN	250-1 L6	3-SPD. MAN.	2.93	61.3	200.3	54.2	69.9	
	4XB27		2-DOOR T/P COUPE	231-2 V6							
	17		2-DOOR HATCH BK CPE	250-1 L6							
	4XC69	111.0	4-DOOR T/P SEDAN	250-1 L6	3-SPD. AUTO.	2.56					54.2
	4XC27		2-DOOR T/P COUPE	231-2 V6							
	17		2-DOOR HATCH BK CPE	250-1 L6							
A	4AD37	112.0	2-DOOR COLONNADE CPE	231-2 V6	3-SPD. MAN.	2.93	61.1	209.5	53.5	79.0	
	29	116.0	4-DOOR COLONNADE SDN								
	4AH57	112.0	2-DOOR COLONNADE CPE								
	29	116.0	4-DOOR COLONNADE SDN								
	4AJ57	112.0	2-DOOR COLONNADE CPE								
	29	116.0	4-DOOR COLONNADE SDN								
	4AF35	116.0	4-DOOR 2-SEAT WAGON 4-DOOR 3-SEAT WAGON					3-SPD. AUTO.	3.08		218.2
4AK35	116.0	4-DOOR 2-SEAT WAGON 4-DOOR 3-SEAT WAGON									
B	4BN57	124.0	2-DOOR COUPE HARDTOP	350-4 V8	3-SPD. AUTO.	3.08	63.6	226.9	53.8	80.0	
	39		4-DOOR HARDTOP								
	69		4-DOOR SEDAN T/P								
	4BP57	124.0	2-DOOR COUPE HARDTOP								
	67		2-DOOR CONVERTIBLE								
	39		4-DOOR HARDTOP								
	69	4-DOOR SEDAN T/P									
4BR35	127.0	4-DOOR 2-SEAT WAGON 4-DOOR 3-SEAT WAGON	455-4 V8	3-SPD. AUTO.	2.93	63.6	231.8	58.4	80.0		
C	4CV37	127.0	2-DOOR COUPE HARDTOP	455-4 V8	3-SPD. AUTO.	2.73	63.6	233.4	54.6 (C) 55.1 (S)	80.0	
	39		4-DOOR HARDTOP								
	4CX37	127.0	2-DOOR COUPE HARDTOP								
	39		4-DOOR HARDTOP								
E	4EZ87	122.0	2-DOOR COUPE HARDTOP	455-4 V8	3-SPD. AUTO.	2.93	63.6	223.0	53.7	80.0	

5B0A9

Figure OA-9 - 1975 Standard Specifications

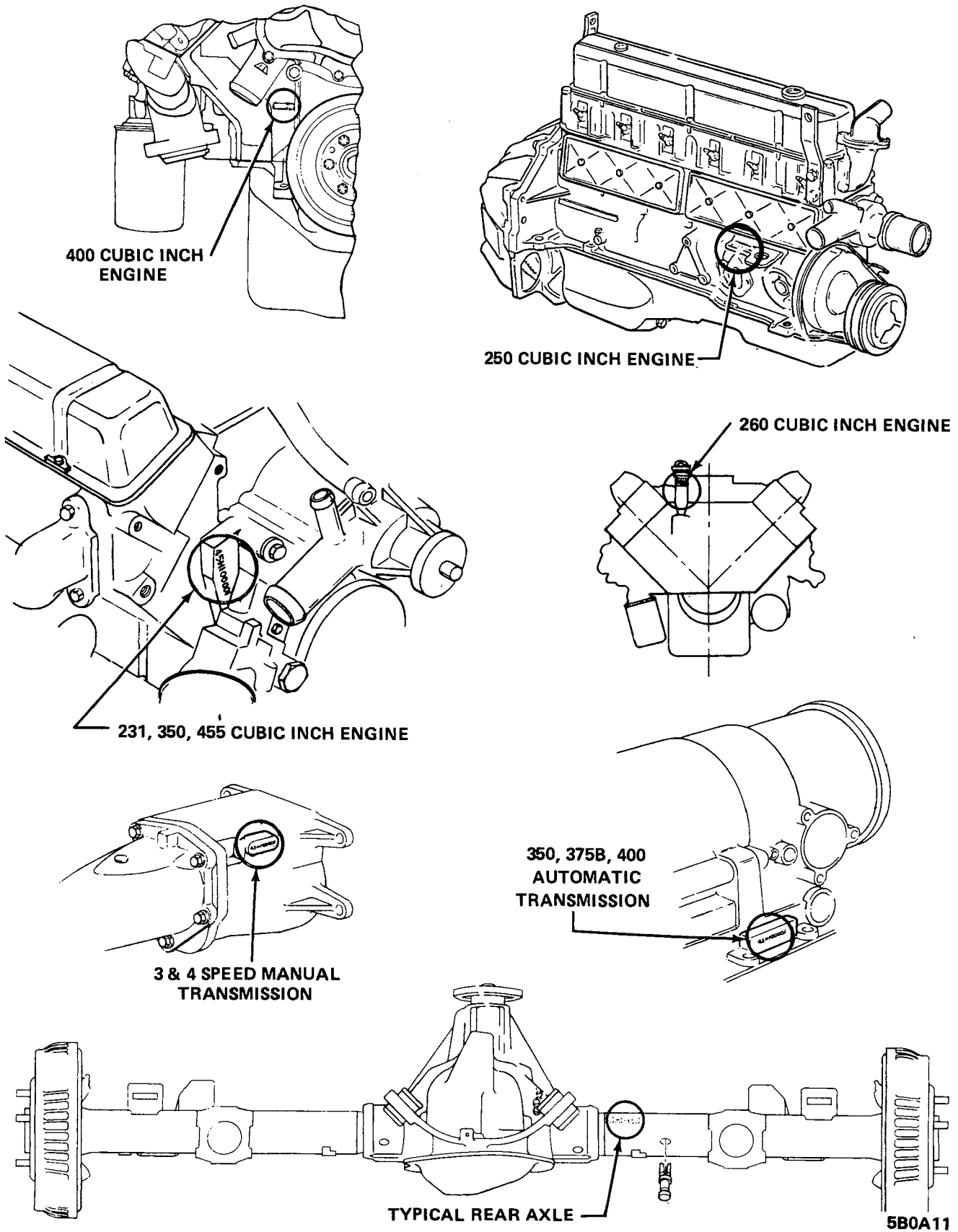

Figure 0A-10 Major Component Serial Number Locations