

CRUISE MASTER A-B-C-E SERIES

WARNING: IF EQUIPPED WITH AIR CUSHION RESTRAINT SYSTEM, DO NOT ATTEMPT ANY ADJUSTMENT, REPAIR OR REMOVAL OF ANY ACCESSORY OR COMPONENTS WHICH WOULD REQUIRE REMOVAL OR DISCONNECTING OF ANY COMPONENT OF THE AIR CUSHION RESTRAINT SYSTEM UNTIL THE DISCONNECTION PROCEDURE IS COMPLETED. THIS PROCEDURE MUST BE FOLLOWED TO PREVENT ACCIDENTAL DEPLOYMENT OF THE SYSTEM WHICH COULD RESULT IN PERSONAL INJURY AND/OR DAMAGE TO THE SYSTEM'S COMPONENTS.

A.C.R.S. DISCONNECTION PROCEDURE

1. Turn ignition switch to "LOCK" position. Disconnect the negative battery cable from the battery and tape end.

CONTENTS

Subject	Page No.
DESCRIPTION AND OPERATION:	
Description of Cruise Master	9E-341
Operation of Cruise Master	9E-342
DIAGNOSIS:	
Quick Check Trouble Diagnosis Chart	9E-343
Electrical Check-Out	9E-344
MAINTENANCE AND ADJUSTMENT:	
Adjustment and Service Procedures	9E-345
MAJOR REPAIR: (Not Applicable)	
SPECIFICATIONS: (Not Applicable)	

DESCRIPTION AND OPERATION

Cruise Master is a driver-operated cruise control system which maintains desired vehicle speed by regulating throttle position. It may be either factory or dealer installed.

Driver Operation

1. *Engagement* - The driver accelerates to the speed at which he desires to cruise and partially depresses and releases the cruise master engagement switch button located at the end of the directional signal lever. The cruise system immediately takes over speed control and, within engine limitation, maintains this speed regardless of changes in terrain.

The engagement switch must be released slowly. If the button is released too fast, the transducer may not have enough time to engage.

The engagement switch button performs these functions:

(a) When depressed halfway, it engages the system.

(b) When depressed fully and held there, it disengages the system.

(c) When released completely, it holds the system in engagement. (The lowest speed at which the system should be used is 40 MPH).

When the system is engaged the cruise lamp will light, indicating that the system is engaged.

2. *Disengagement* - The system automatically disengages whenever the brake is depressed or the ignition switch turned off.

The cruise lamp will go out, indicating that the system is no longer in use.

3. *Speed Adjustment* -

(a) Upward - Depress the accelerator pedal to the new desired speed. Then fully depress and slowly

release the cruise master engagement switch button. The system re-engages at the higher speed when the button is released.

(b) Downward - Disengage the system by depressing the engagement switch button fully and holding it there until the car has decelerated to the new desired speed; then release the button slowly.

4. *Override* - The accelerator pedal may be depressed at any time to override the cruise system. Release of the accelerator pedal will return the car to the previous cruise speed.

Cruise Master Units

1. *The engagement switch*, which is located at the end of the directional signal lever, is used to control the system and for upward and downward speed adjustments.

2. *The speed transducer*, which is mounted in the speedometer cable line, is a combination speed sensing device and control unit. When engaged, it senses vehicle speed and positions the power unit to maintain the selected speed. It also provides a ground path for the cruise lamp.

3. *The power unit*, which is mounted at the rear of the engine, is connected by a ball chain to the throttle linkage. It opens or closes the throttle as dictated by the speed transducer.

4. *The cruise brake release switch*, which is mounted on the brake pedal bracket, disengages the system electrically when the brake pedal is depressed.

5. *The cruise brake release valve*, which is mounted on the brake pedal bracket, disengages the system pneumatically when the brake pedal is depressed.

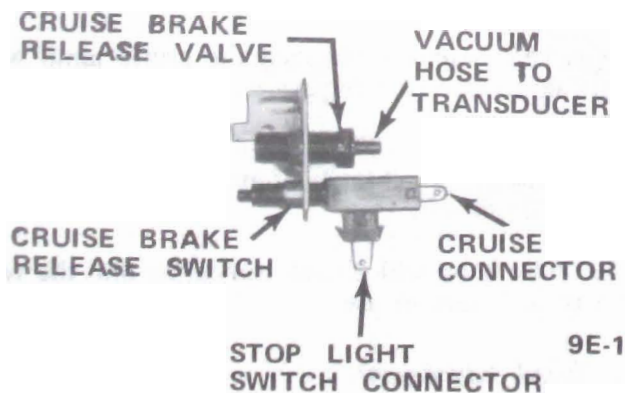
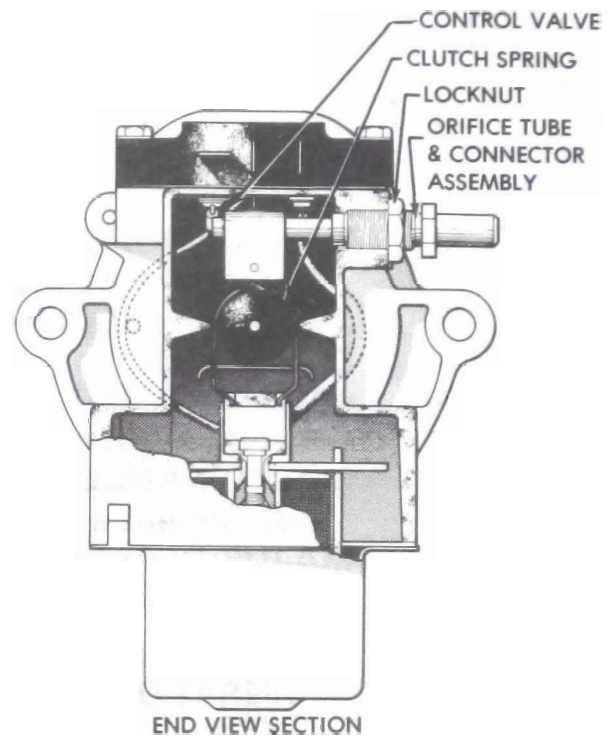

Figure 9E-1 Cruise Brake Release Switch and Valve Assembly

6. *The cable and casing assemblies* drive the transducer and speedometer.

Operation of Cruise Master

The transducer consists of two sub-assemblies: The magnet housing assembly and the solenoid and clutch housing assembly. The magnet housing assembly contains the drive adapter assembly, magnet and shaft assembly, and the speed disc field plate and spindle assembly. See Figures 9E-2 and 9E-3.



9E-2

Figure 9E-2 - Cruise Master Speed Transducer-End Section View

The solenoid and clutch housing contains the orifice tube and connector assembly, the control valve, the engagement clutch spring, the low speed switch, the engagement solenoid assembly, and the air filter assembly.

The power unit consists of a diaphragm and return spring. The vacuum level of the sealed chamber is controlled by the transducer. The ball chain connects directly to the throttle linkage to control carburetor throttle position. See Figure 9E-4.

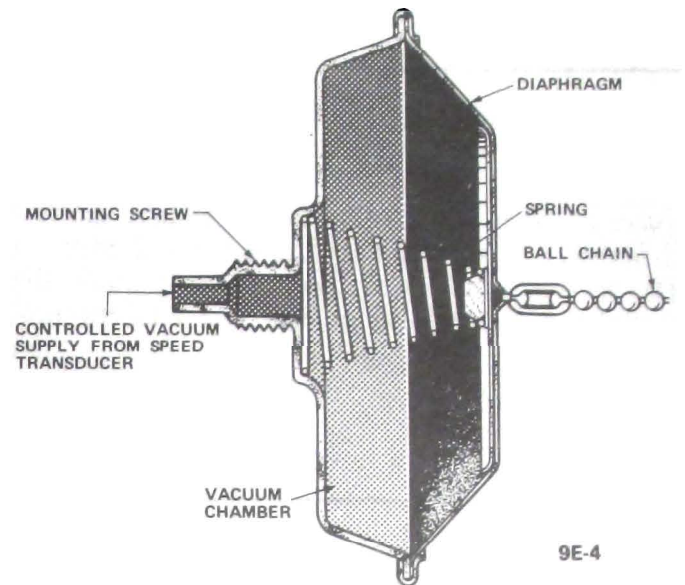
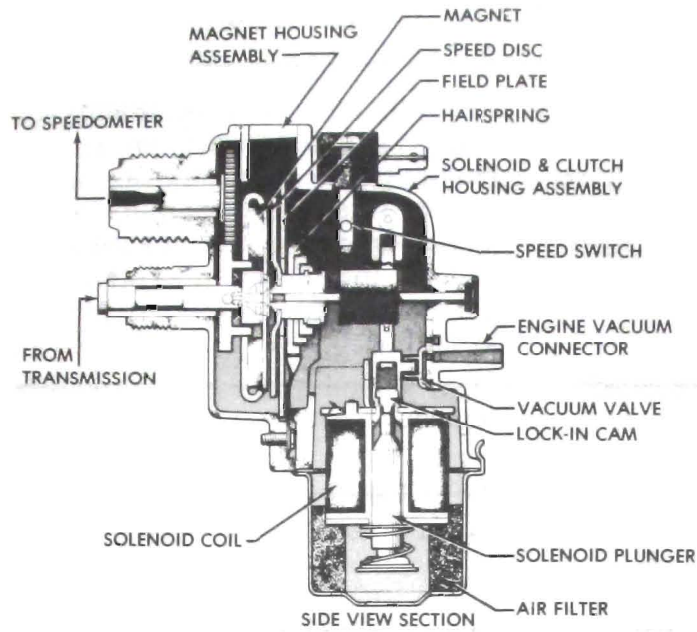

Figure 9E-4 - Power Unit

- Figure 9E-3 Cruise Master Speed Transducer - Side View Section

QUICK-CHECK TROUBLE DIAGNOSIS CHART

Condition	Possible Cause	Correction
System inoperative but cruise light comes on.	1. Bead chain from power unit to throttle disconnected.	1. Connect bead chain and adjust.
	2. Large vacuum leak. Vacuum hose disconnected.	2. Check all vacuum lines. Check for broken vacuum manifold. Repair or replace as required.
	3. Restricted or plugged vacuum line.	3. Check for kinks or collapsed vacuum line. Remove restriction.
	4. Brake pedal vacuum release valve out of adjustment.	4. Adjust.
System inoperative and cruise light stays off.	1. Brake switch out of adjustment.	1. Adjust.
	2. Loose electrical connections.	2. Check and secure all electrical connectors, transducer, brake switch, cruise engage switch and fuse block.
	3. Fuse blown.	3. Replace fuse.

Condition	Possible Cause	Correction
	4. Malfunctioned turn signal and engage switch assembly.	4. Substitute new turn signal and engage switch assembly by plugging into connector at bottom of steering column. Check operation and, if satisfactory, install new turn signal and engage switch assembly.
	5. Malfunctioned transducer.	5. Replace.
Speed increases after engagement.	1. Transducer orifice tube out of adjustment.	1. Adjust.
	2. Partially plugged transducer filter.	2. Replace. If original filter is cleaned, glycol <u>must</u> be added.
Speed drops off after engagement.	1. Bead chain too loose. Vacuum leak or restriction.	1. Check for split or disconnected hoses, cracked vacuum manifold, pinched or kinked hoses. Repair or replace as required. Adjust bead chain.
	2. Transducer orifice tube out of adjustment.	2. Adjust

ELECTRICAL CHECK-OUT

1. Check all fuses and connections.
2. Check adjustment of cruise brake release switch and brake release valve.
3. Check cruise master engagement switch as follows:
 - (a) Disconnect switch connector from wiring harness at lower part of steering column (refer to Figure 9E-18 for location of terminal numbers and for circuit function) as required perform the following test.

Test No. 1 - Connect ohmmeter between Terminal No. 1 (brown wire) and Terminal No. 2 (blue wire). Continuity shall be maintained until switch is depressed all the way in.

Test No. 2 - Connect ohmmeter between Terminal No. 1 (brown wire) and Terminal No. 3 (black). No continuity shall be shown; however, when the button is depressed partially, continuity shall be indicated.

When the button is pressed all the way down, no continuity shall be shown.

Test No. 3 - Connect ohmmeter between Terminal No. 2 (blue wire) and Terminal No. 3 (black). Button released, no continuity; however, when the button is depressed partially and fully, continuity shall be shown.

4. With the cruise master engagement switch connector disconnected as in Step 3, above, disconnect battery and check wiring harness and circuitry as follows:

(a) Connect an ohmmeter at appropriate terminals and junction points as indicated in the schematic diagram of Figure 9E-17 to measure the following resistances:

- (1) Harness brown-white resistance wire, R1, which is approximately 40 ohms.
- (2) Transducer solenoid coil resistance, which is 5.2 plus or minus 0.2 ohms.

Note that these resistance values are given for parts at normal room temperatures of 68-72 degrees F. Use care to disconnect transducer as needed to eliminate possible parallel paths to ground when making resistance checks. Except for the brown-white resistance wire, all harness wires shall indicate zero resistance (continuity) when checked per the schematic of Figure 9E-17. If values of resistance other than those indicated above occur, take corrective action and repair or replace as required.

(b) Check cruise lamp bulb if indicated. Replace if required.

(c) Replace cruise master switch connector and reconnect battery.

MAINTENANCE AND ADJUSTMENTS

ADJUSTMENTS AND SERVICE PROCEDURES

Power Unit Bead Chain Adjustment

1. Adjust engine curb hot idle speed (350-455 engine) idle stop solenoid disconnected, to 500 RPM, then shut off engine.

2. Check bead chain slack by unsnapping swivel from ball stud and holding chain taut at ball stud; center of swivel should extend 1/8 inch beyond center of ball stud. See Figure 9E-10.

3. Adjust bead chain slack if necessary, by removing the retainer from the swivel and chain assembly. Place chain into swivel cavities which permits chain to have slight slack. Place retainer over swivel and chain assembly.

Brake Release Switch and Valve Adjustment

With brake pedal fully depressed, push switch and valve forward until they stop against bracket or arm, pull pedal rearward with 15-20 lbs. force to properly adjust switch and valve.

Cruise Speed Adjustment

If the car cruises at a speed above or below the engagement speed, this error can be corrected with a simple adjustment of the orifice tube in the transducer. See Figure 9E-5.

1. To check cruise speed error, engage Cruise Master at exactly 60 MPH.

2. If car cruises below engagement speed, screw orifice tube outward.

3. If car cruises above engagement speed, screw orifice tube inward. Each 1/4 turn of the orifice tube will change cruise speed approximately one MPH. Snug-up lock nut after each adjustment before testing.

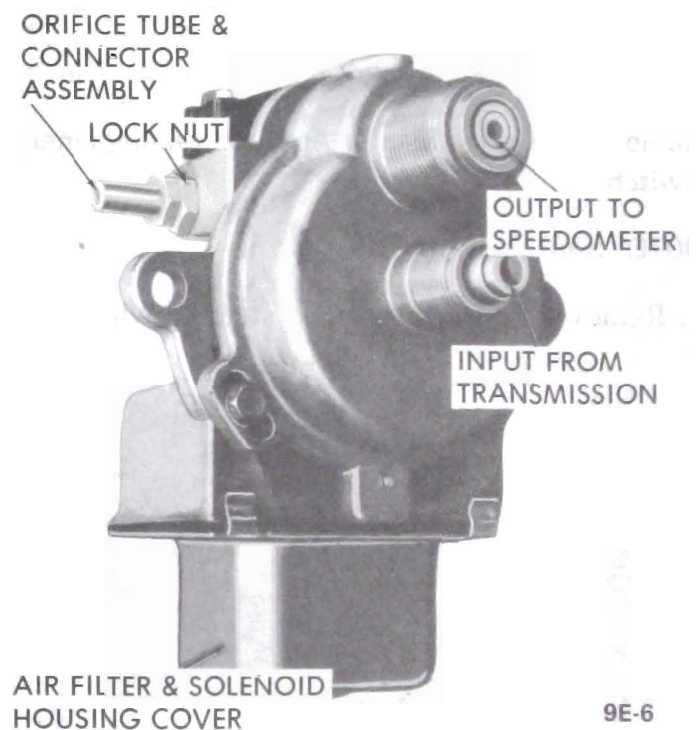

Figure 9E-5 - Speed Transducer

Transducer Air Filter Replacement

1. Replace air filter when it becomes contaminated. When making the replacement:

(a) Place polyurethane filter in bottom of solenoid and filter cover. Note rectangular shape of filter and cover. See Figure 9E-6.

(b) Position the solenoid and filter cover and its rubber gasket to the solenoid housing casting and *secure with the cover retaining clips*. Use care to insure that a tight gasket seal is obtained.

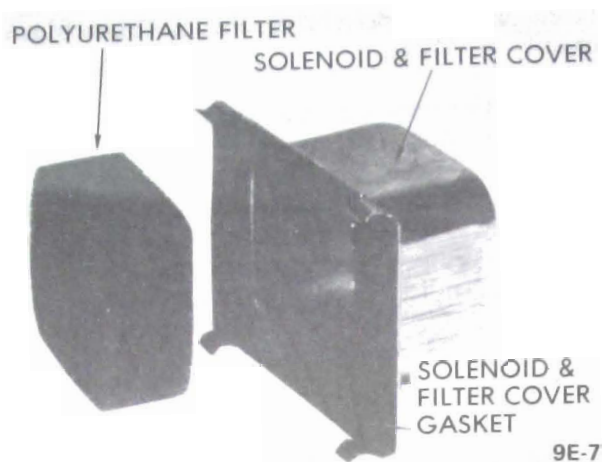

Figure 9E-6 - Replacing Cruise Master Air Filter

Removal of Cruise Master Actuating Engagement Switch

NOTE: *Shift lever must be in low.*

1. Remove horn actuator and steering wheel.

2. Remove cover plate (three screws).
3. Remove turn signal lever screw and conduit from wire assembly.
4. Attach fine pliable wire through hole in connector. Tape end of wire and connector.
5. Pull switch and wire assembly through column. (Threading pliable wire).
6. Attach and tape wire to new connector.
7. Pull connector and wire through column.
8. Replace conduit on wire assembly.
9. Install turn signal lever screw.
10. Install cover plate.
11. Install steering wheel and horn actuator.

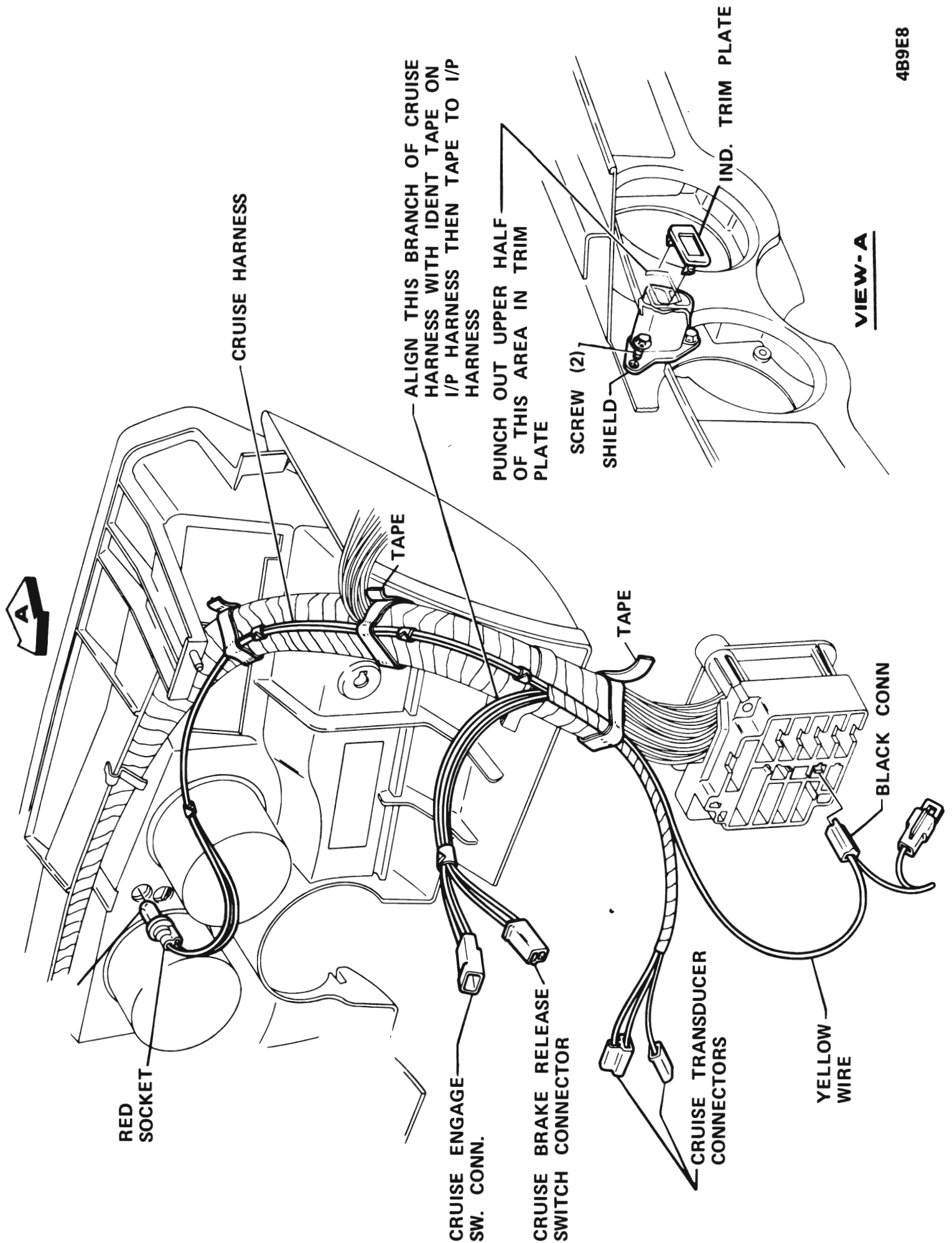

4B9E8

Figure 9E-7 Cruise Master - Passenger Compartment - A Series

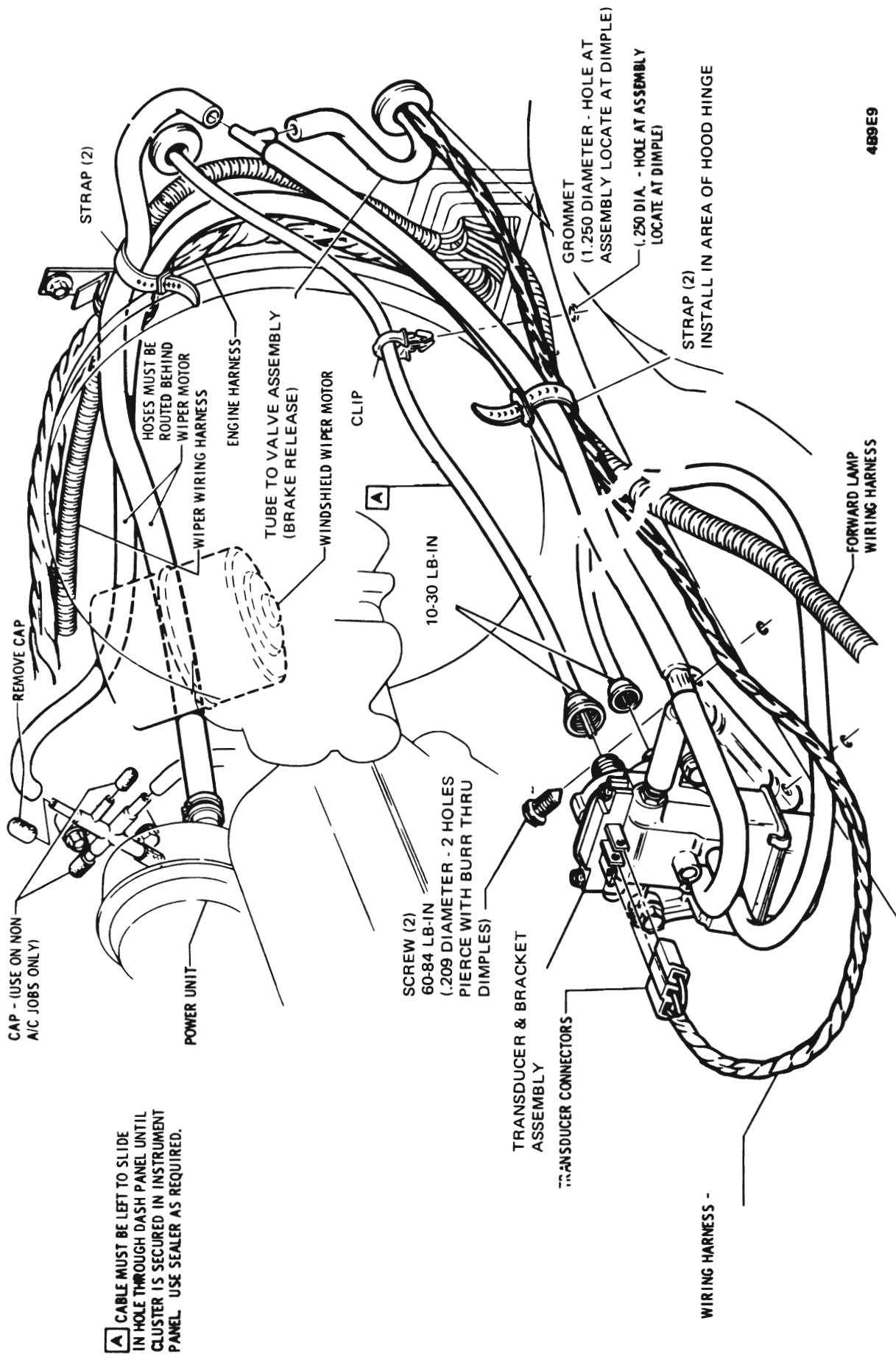

489E9

Figure 9E-8 Cruise Master - Transducer and Hose Routing - A Series

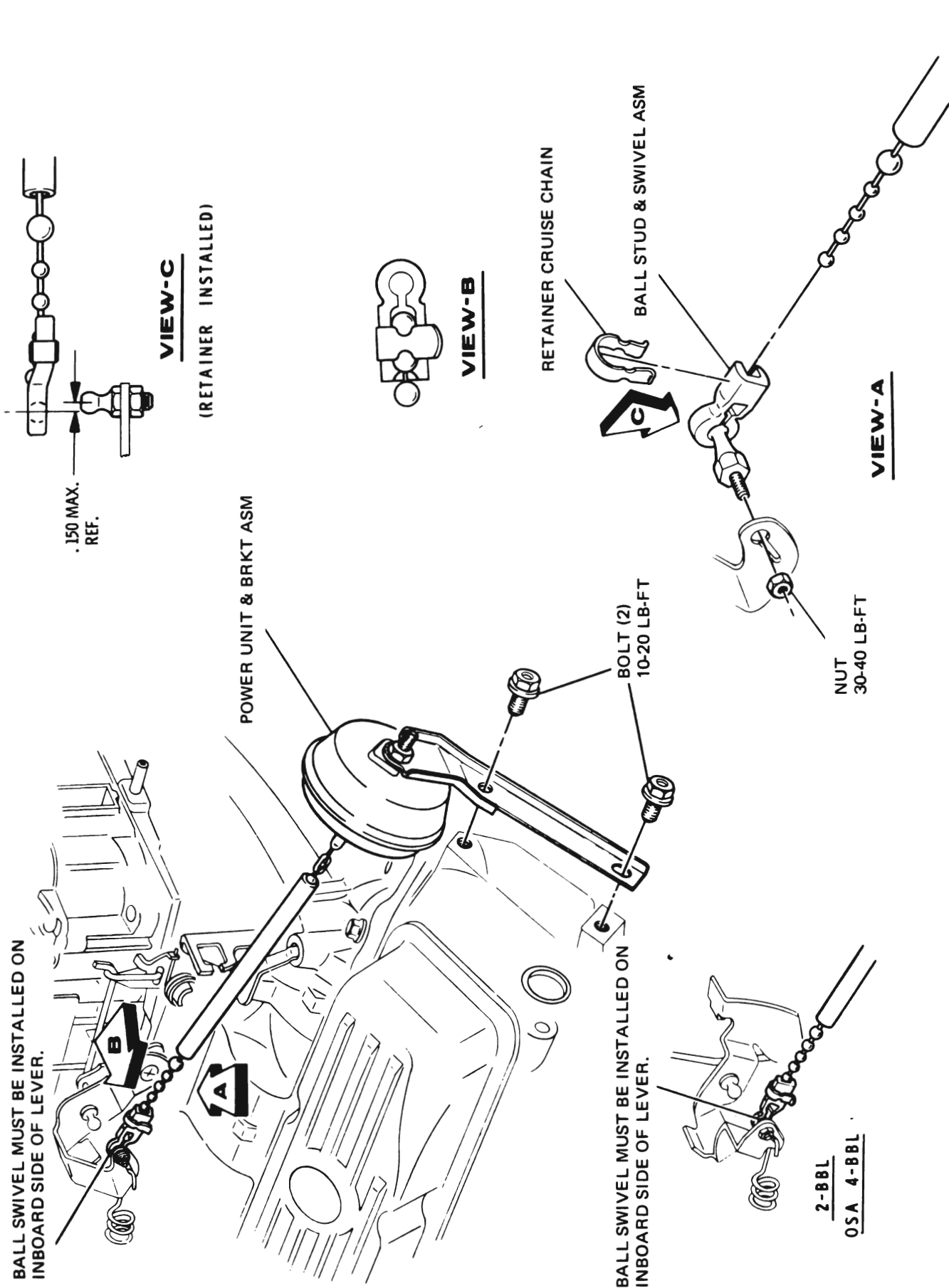

Figure 9E-10 Cruise Master Power Unit - 350 and 455 Engines

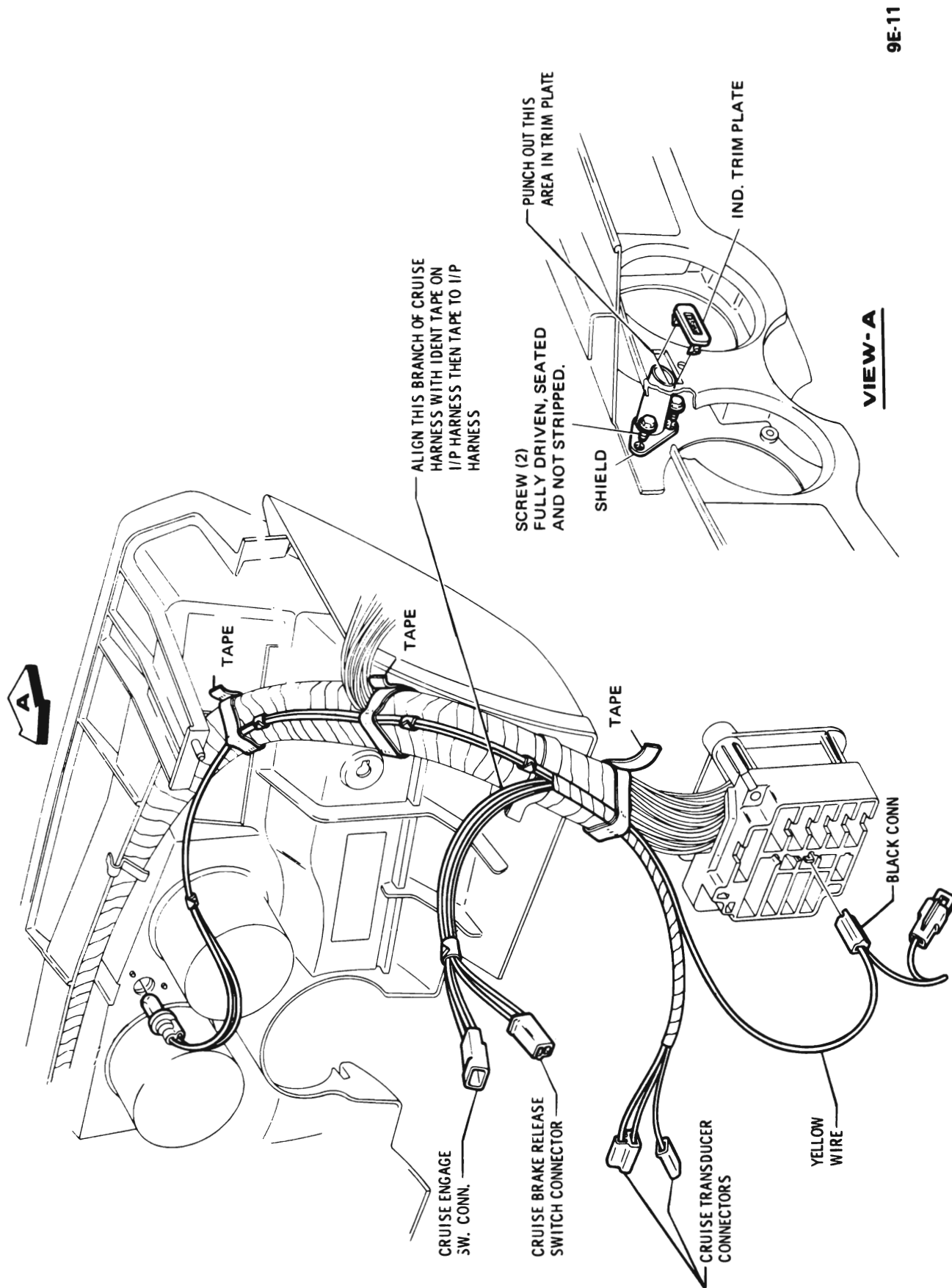

Figure 9E-11 Cruise Master - Passenger Compartment - "A" Series

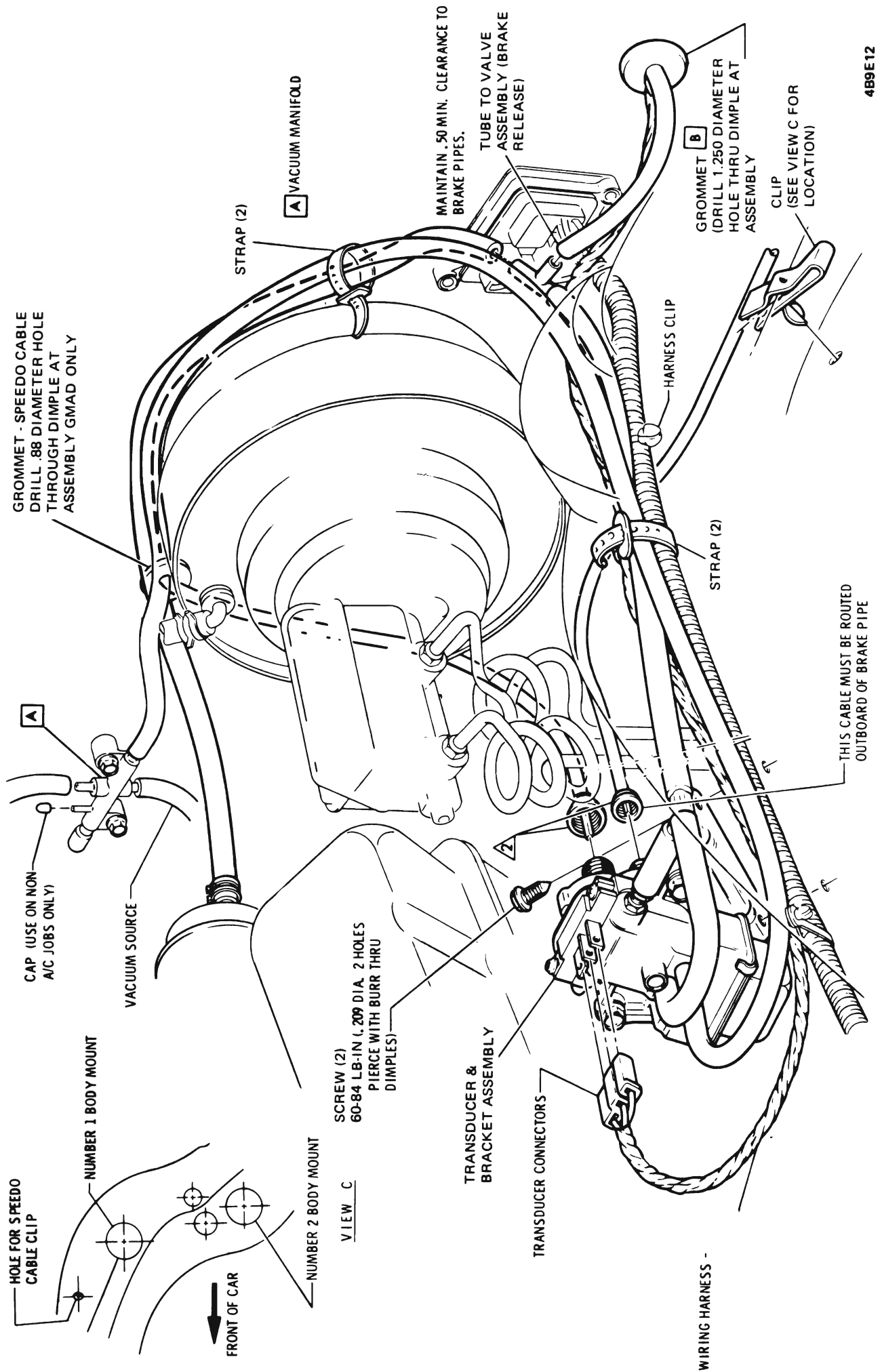

Figure 9E-12 Cruise Master Transducer and Hose Routing - B-C-E Series

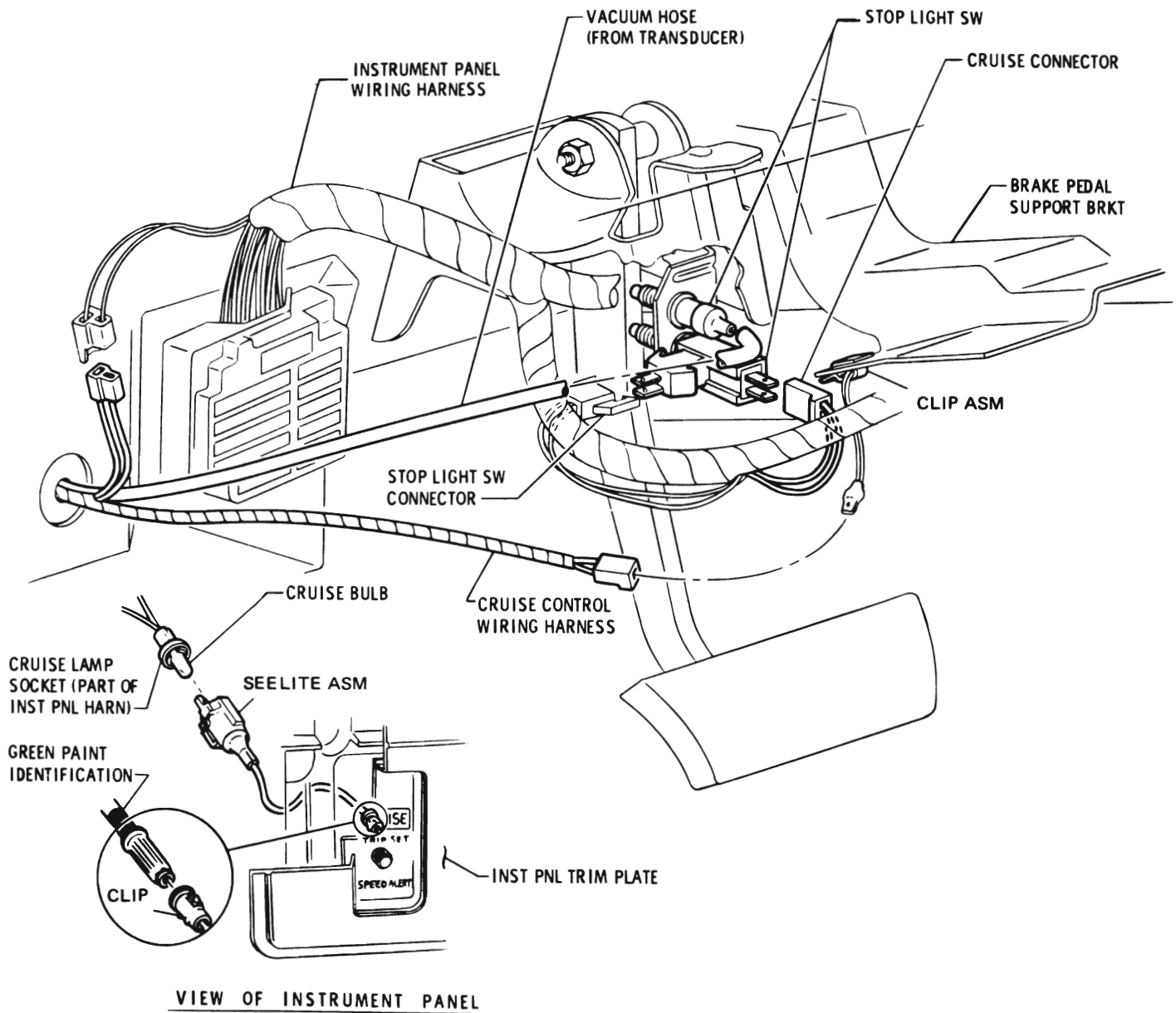

Figure 9E-13 Cruise Master Passenger Compartment - B-C-E Series

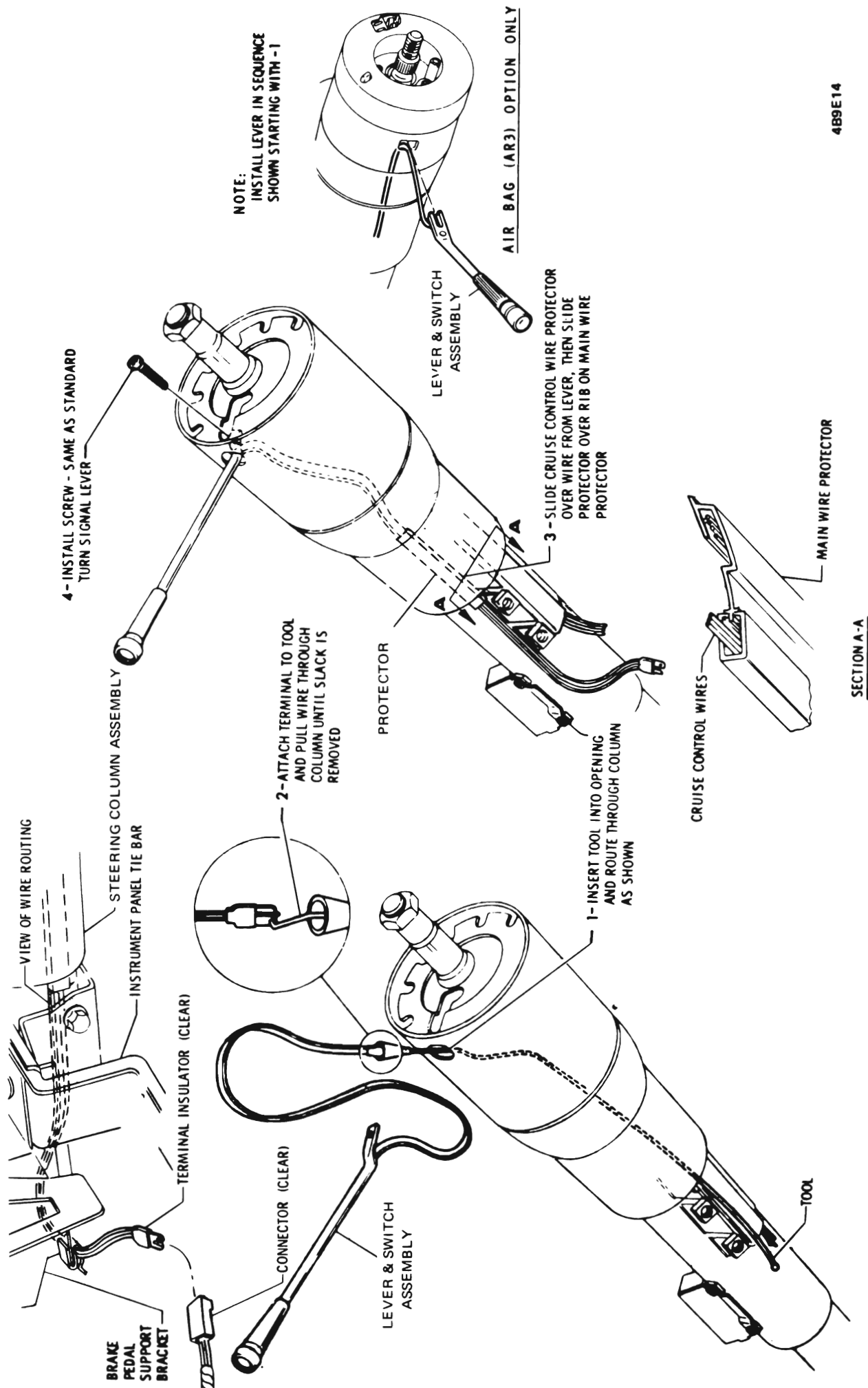

Figure 9E-14 Cruise Master Lever and Switch Wire Routing - A-B-C-E Series

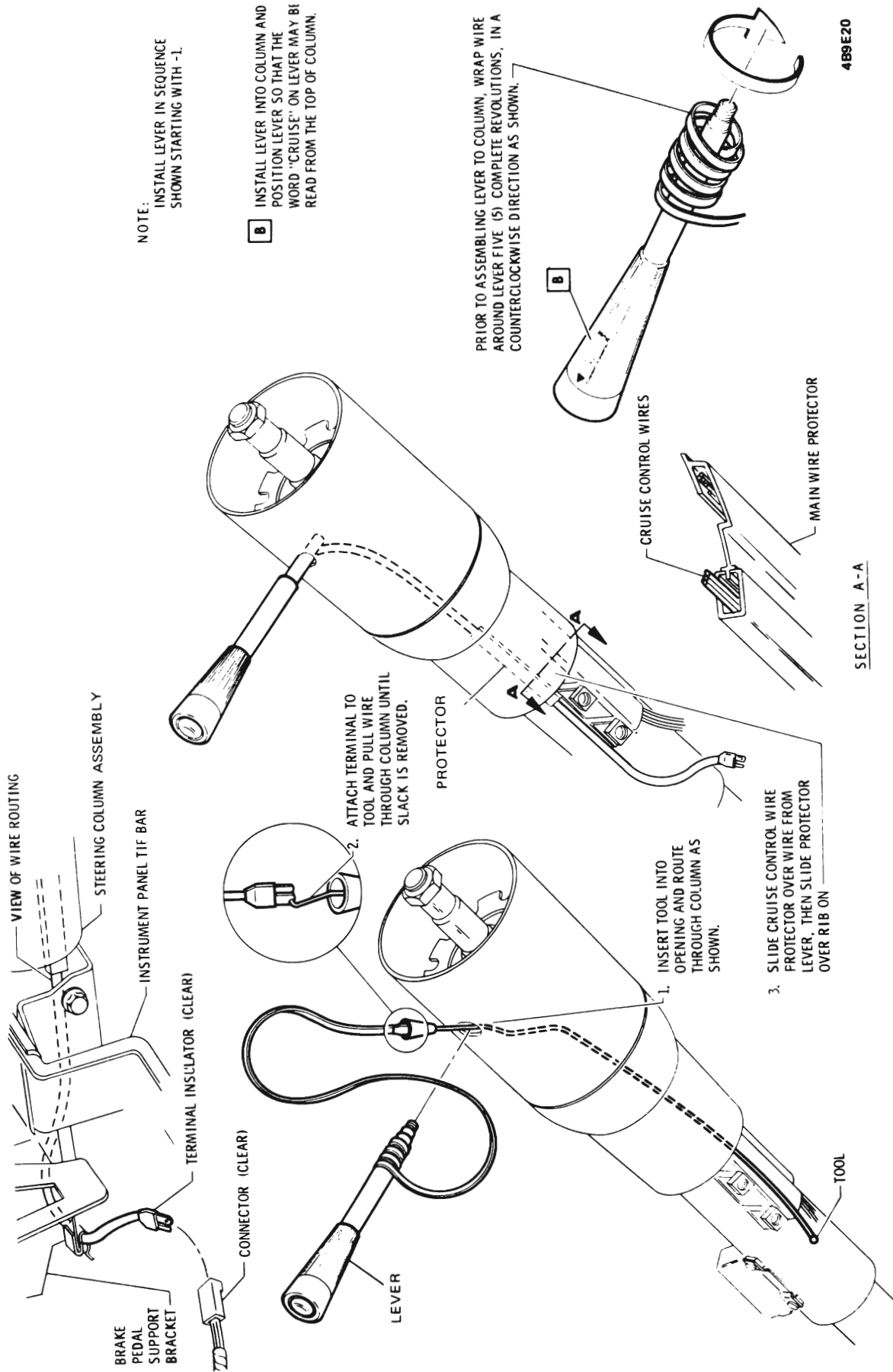
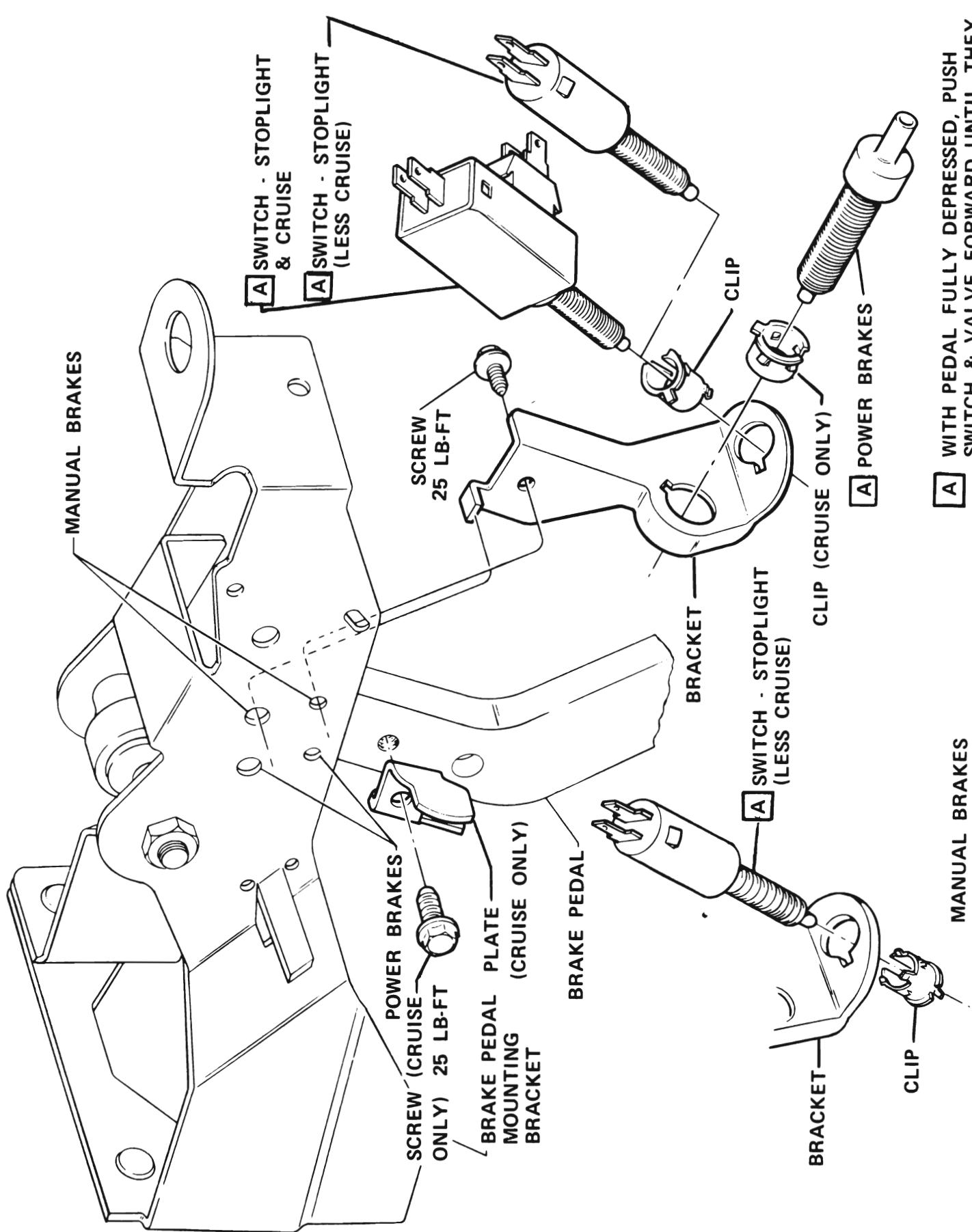

Figure 9E-15 Cruise Master Lever and Switch Wire Routing - Tilt and Telescoping Column - B-C-E Series



A WITH PEDAL FULLY DEPRESSED, PUSH SWITCH & VALVE FORWARD UNTIL THEY STOP AGAINST BRACKET OR ARM, PULL PEDAL REARWARD WITH 15-20 LBS. FORCE TO PROPERLY ADJUST SWITCH & VALVE.

4B9E15

Figure 9E-16 Stoplight - Cruise and Vacuum Switches - "A" Series

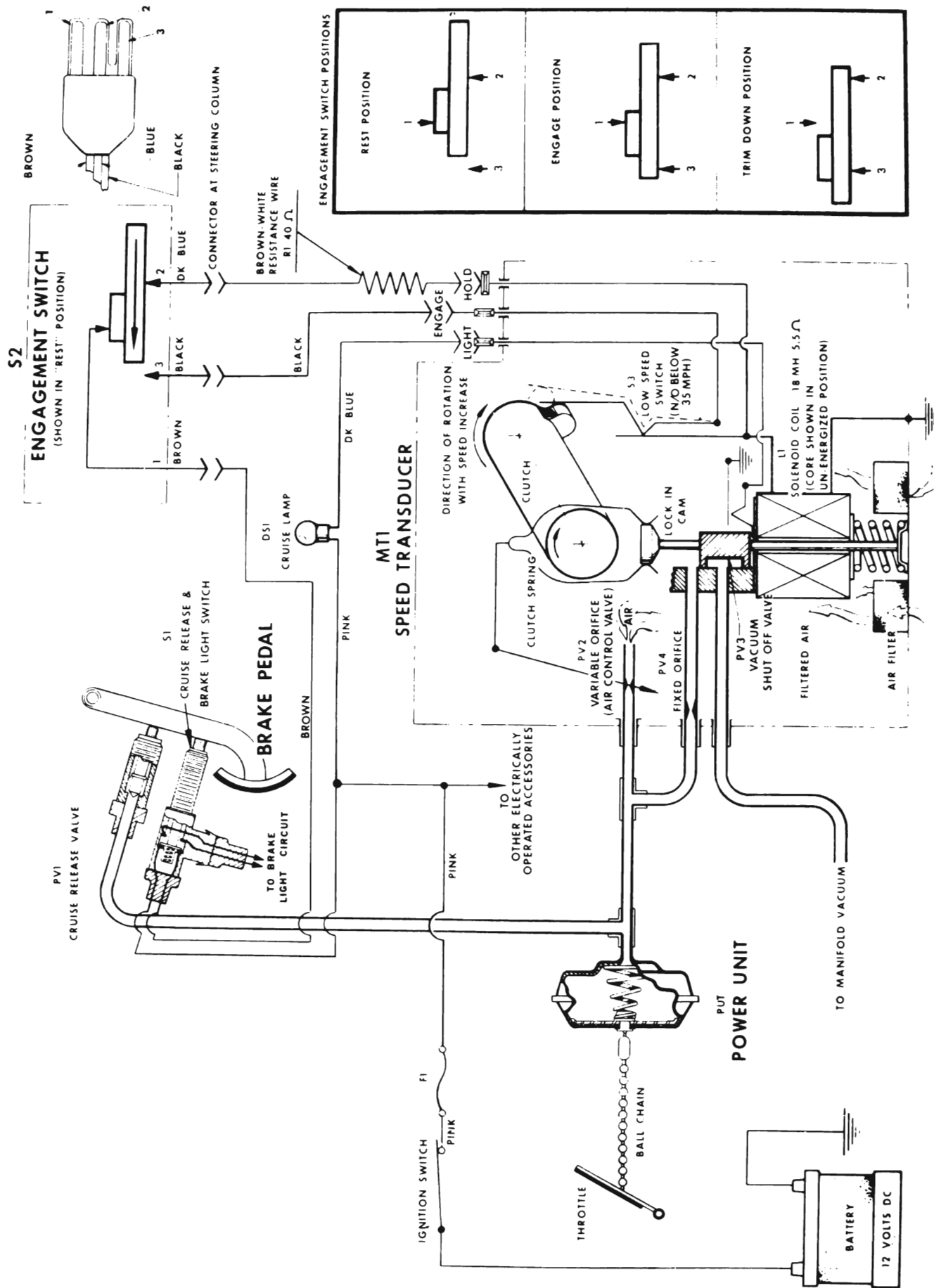
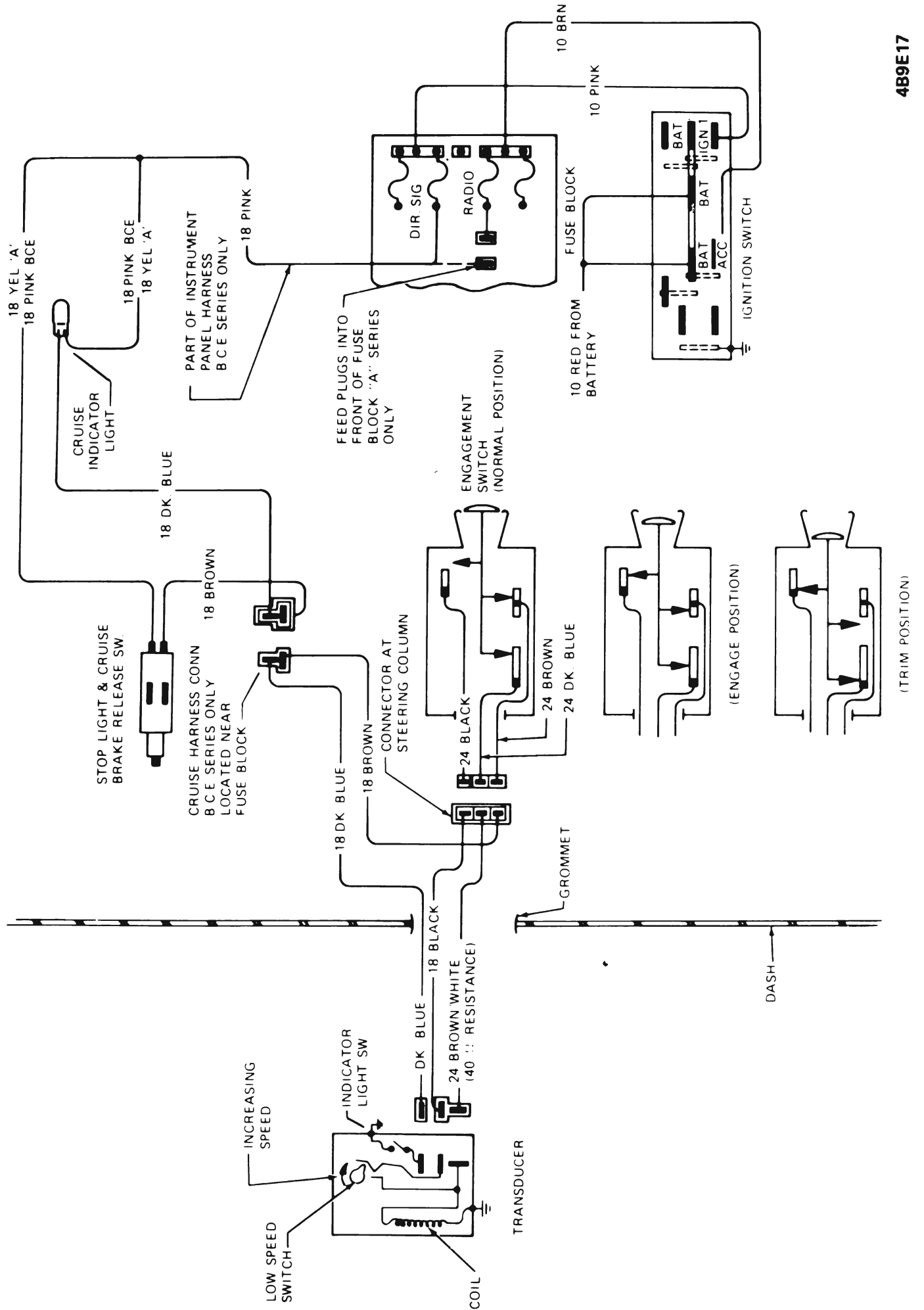

Figure 9E-17 Cruise Master Electro - Pneumatic Schematic



4B9E17

Figure 9E-18 Cruise Master Wiring Diagram

