

MAX-TRAC SYSTEM

B-C-E SERIES

WARNING: IF EQUIPPED WITH AIR CUSHION RESTRAINT SYSTEM, DO NOT ATTEMPT ANY ADJUSTMENT, REPAIR OR REMOVAL OF ANY ACCESSORY OR COMPONENTS WHICH WOULD REQUIRE REMOVAL OR DISCONNECTING OF ANY COMPONENT OF THE AIR CUSHION RESTRAINT SYSTEM UNTIL THE DISCONNECTION PROCEDURE IS COMPLETED. THIS PROCEDURE MUST BE FOLLOWED TO PREVENT ACCIDENTAL DEPLOYMENT OF THE SYSTEM WHICH COULD RESULT IN PERSONAL INJURY AND/OR DAMAGE TO THE SYSTEM'S COMPONENTS.

A.C.R.S. DISCONNECTION PROCEDURE

1. Turn ignition switch to "LOCK" position. Disconnect the negative battery cable from the battery and tape end.

CONTENTS

Subject	Page No.
DESCRIPTION AND OPERATION:	
General Description	9D-327
Operation of Max-Trac System	9D-329
DIAGNOSIS:	
Diagnosis Chart	9D-329
MAINTENANCE AND ADJUSTMENTS:	
Adjustments	9D-331
MAJOR REPAIR:	
Removal and Installation of Max-Trac Components	9D-331
SPECIFICATIONS: (Not Applicable)	

DESCRIPTION AND OPERATION

The purpose of the Max-Trac System is to aid the operator in maintaining vehicle directional stability and maneuverability during acceleration and/or cornering. The system accomplishes this purpose by automatically limiting engine power to a value required for maximum acceleration without excessive rear wheel slippage.

Basic system components include the transmission speed sensor, front wheel speed sensor and speed disc, electronic controller, "on-off" switch, and electrical harness. In addition, the system uses the existing ignition switch, brake switch, brake light, and ignition components.

1. Transmission Speed Sensor

This sensor is a mechanically driven electro-magnetic device which produces an AC voltage with fre-

quency proportional to the transmission output shaft speed. The sensor is mounted in the transmission at the speedometer cable connection. Its function is to convert the rear wheel speed into an electrical signal at a frequency of 25 Hz/mph. This rear wheel speed signal is transmitted via the electrical harness to the electronic controller.

2. Front Wheel Speed Sensor and Speed Disc

This sensor is an electro-magnetic device which, in conjunction with the rotating speed disc, produces an AC voltage with frequency proportional to the speed of the disc. The speed disc is mounted on the hub of the left front wheel. The sensor is mounted at a predetermined distance from the disc and the gap is adjustable at the sensor mounting. The function of the sensor is to convert the front wheel speed into an electrical signal at a frequency of 6.25 Hz/mph.

This front wheel speed signal is transmitted via the electrical harness to the electronic controller.

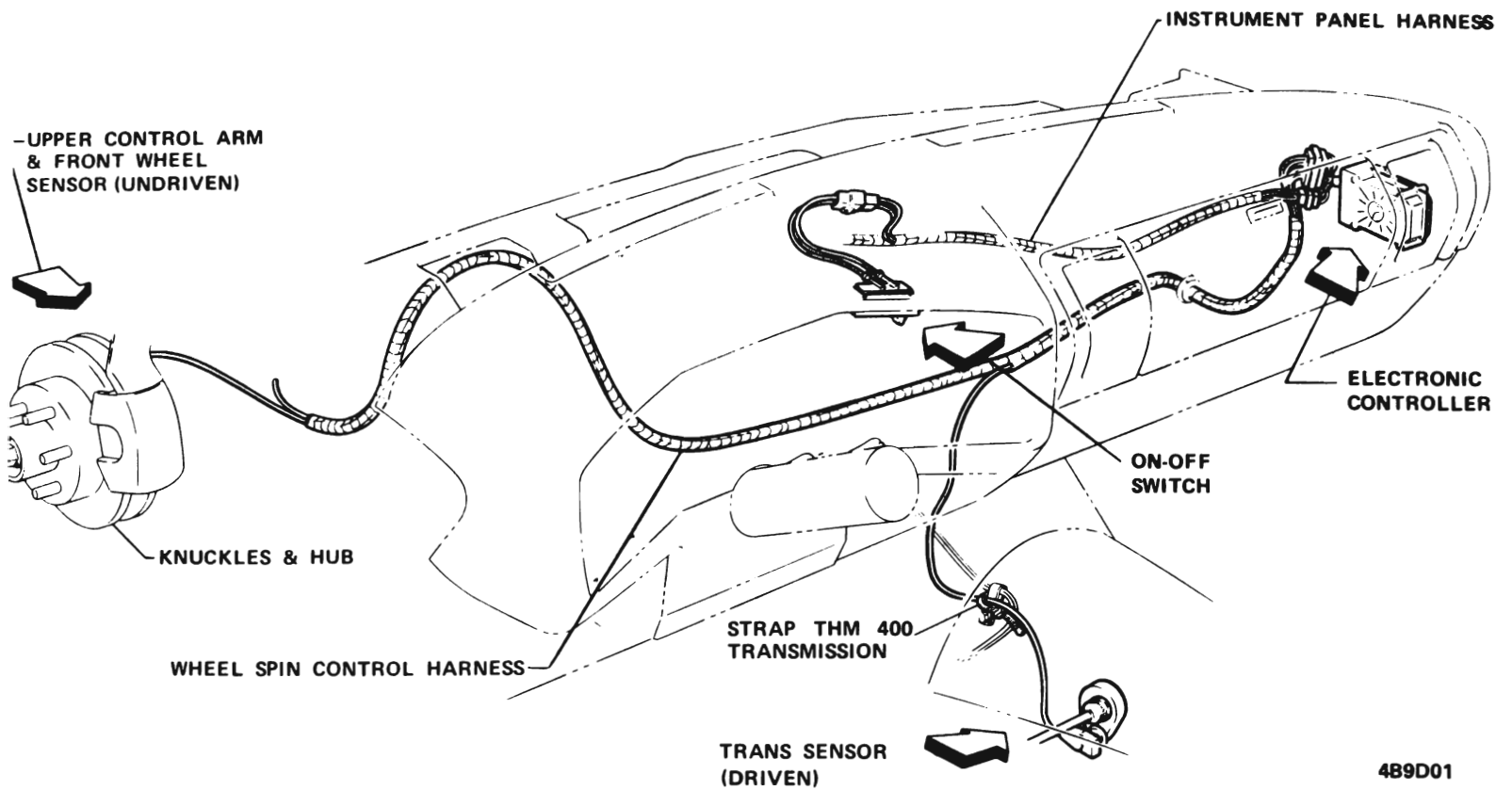

Figure 9D-1 Max-Trac System less Air Cushion Restraint System

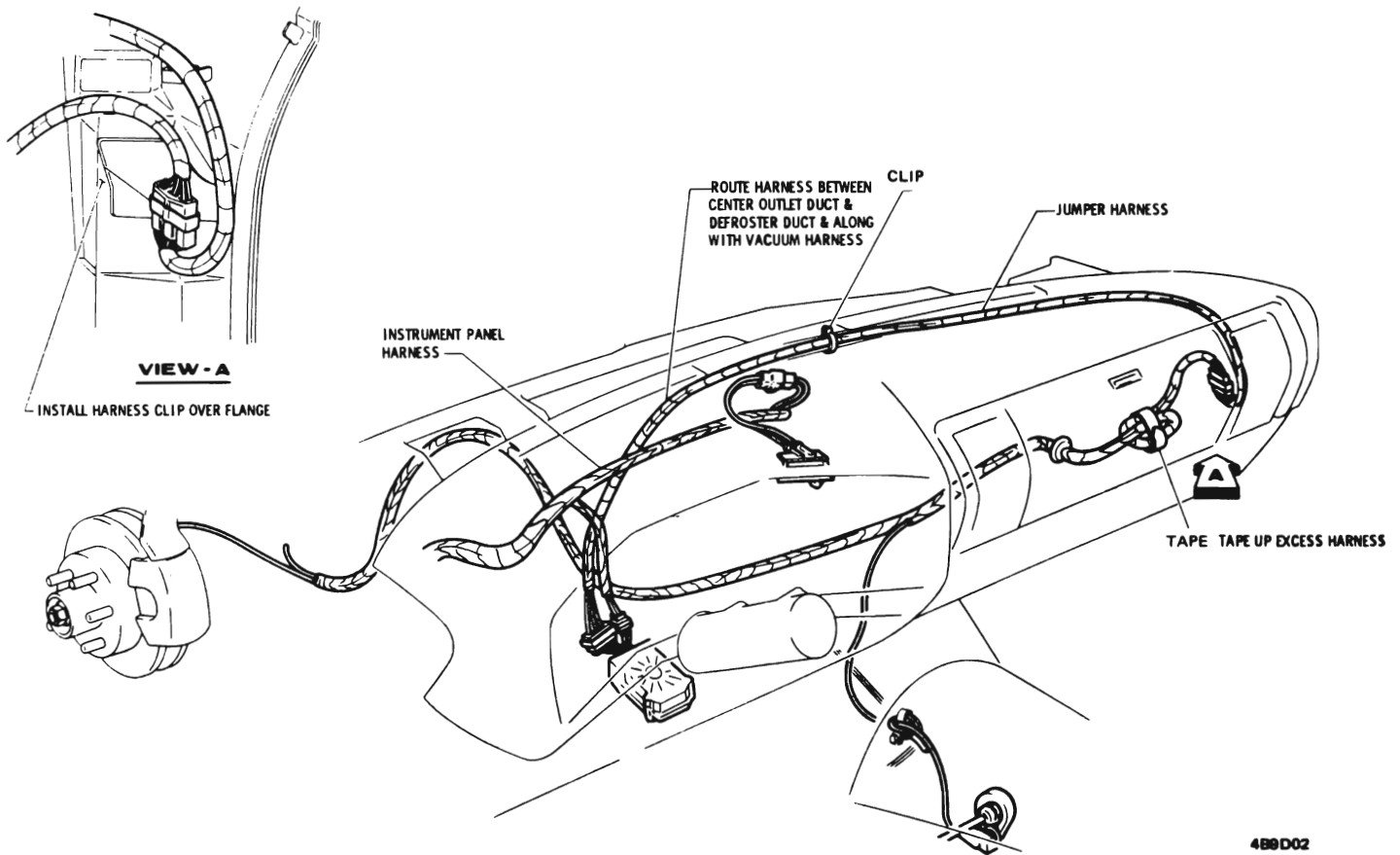

Figure 9D-2 Max-Trac System - Air Cushion Restraint System

3. Electronic Controller

The controller is a solid state electronic computer and is mounted in the passenger compartment. It receives the driven and undriven wheel speed signals from the sensors. Its function is to compare the two-speed signals and, when the difference exceeds a predetermined amount, to generate a 30 Hz output signal with a duty cycle proportional to the speed difference. This output signal is transmitted via the electrical harness to the ignition system.

4. "On-Off" Switch

The "on-off" switch is located on the vehicle's instrument panel. It allows the operator to make the Max-Trac operation optional. It is recommended that the switch normally be in the "on" position. However, it is desirable to have the system inoperative under certain driving conditions, i.e., rocking the car in snow. Also, should a malfunction in the system occur, the vehicle may be driven with the switch "off" until repairs are made. In the "off" position, this switch shorts the controller output signal and prevents it from being transmitted to the ignition system.

5. Electrical Harness

The harness provides the electrical connection between the sensors, controller, power source, ignition switch, brake switch, and ignition coil.

Refer to Figure 9D-7 for replacing an upper control arm on cars with the Max-Trac option. Two new holes in the control arm for the wiring harness clips must be drilled as shown.

6. Diverter Valve Solenoid

On cars equipped with Max-Trac and A. I. R., a solenoid is mounted on the A. I. R. pump to prevent engine back-fire when the Max-Trac is operating. See Figure 9D-8.

OPERATION

The components of the Max-Trac System are interconnected, as shown in Figure 9D-10. The system is not operable whenever the ignition switch is "off" and/or the "on-off" switch is "off" and/or the brakes are applied. When the ignition switch is "on", the vehicle can be driven in the normal manner without Max-Trac operation, regardless of the amount of rear wheel slippage.

The system is operable whenever the ignition switch is "on" and the "on-off" switch is "on" and the brakes are not applied. The vehicle can then be driven in the normal manner and no ignition interrupts will occur if the slippage does not exceed a predetermined value. However, under particular driving conditions, i.e., excessive acceleration or hard cornering, which reduces the normal load on the rear wheels, the amount of slippage can exceed the predetermined amount. The controller, continuously comparing the speed signals from the 2 sensors, determines that the excessive slippage has occurred and generates an output signal which interrupts the ignition in the prescribed manner, resulting in a power reduction and a corresponding reduction in slippage.

DIAGNOSIS CHART

The following chart, showing "Conditions", "Possible Causes", and "Corrections" is offered as a diagnostic tool to aid in effecting rapid repairs in the event of a malfunctioning Max-Trac System. It is recommended that for each symptom, the possible causes be evaluated in the order shown on the attached chart.

Condition	Possible Cause	Correction
System inoperative at speeds.	1. On-off switch set at "Off".	1. Set switch to "On".
	2. No ground connection to the controller.	2. Unplug 6 terminal connector at controller. The black wire at the controller connector should be grounded. If not, Connect controller ground wire to ground.

Condition	Possible Cause	Correction
	3. Brake lights dead.	3. Check fuse and brake lights switch. Replace or repair as necessary. Check brake lights wiring circuit and bulbs.
	4. No signal from transmission speed sensor (faulty harness or an open circuit in the sender).	4. Unplug 6 terminal connector at controller. Resistance between red and white wires at harness connector should be 1600 to 2400 ohms. If circuit is open, unplug connector at sensor and check resistance across sensor terminals. If open, replace sensor. If 1600 to 2400 ohms, replace the harness.
	5. No signal from front wheel speed sensor (a faulty harness or open circuit in sensor).	5. Unplug 6 terminal connector at controller. Resistance between light green and white wires in harness connector should be 1250 to 1750 ohms. If circuit is open, unplug connector at sensor and check resistance at sensor terminals. If open, replace sensor. If 1250 to 1750 ohms, replace the harness.
	6. Controller faulty.	6. Replace the controller.
Engine will start but will not run until on-off switch is set at "Off".	1. No battery (positive) electrical supply to controller.	1. Unplug 3 terminal connector at controller. With ignition switch "On", battery voltage should be available between the pink wire at the harness connection and ground. If not, repair or replace instrument panel harness.
	2. No connection between controller output and ignition ballast resistor.	2. Unplug 3 terminal connector at controller. Resistance between pink/black wire at harness connector and positive terminal of coil should be 1.8 ohms. If open, repair or replace harness.
	3. Faulty controller.	3. Replace the controller.
System functions or engine stops during braking.	1. No B (positive) from brake circuit.	1. Unplug 3 terminal connector at controller with brakes applied. Battery voltage should be available between white wire and ground. If not, repair or replace instrument panel harness.

Condition	Possible Cause	Correction
	2. Brake lights dead.	2. Repair car harness.
	3. No connection from controller to brake	3. Unplug 3 terminal connector at controller. With the brakes applied, battery voltage should be available between white wire and ground. If not, repair or replace the harness.
	4. Malfunctioned controller.	4. Replace the controller.
System functions properly at high speeds but is inoperative at lower vehicle speeds.	1. Low signal from the front wheel speed sensor (excessive gap between sensor and speed disc).	1. Check the adjust gap between sensor and speed disc at the sensor mounting. Felt spacer should touch the speed disc. If felt spacer is missing, set gap between end of sensor and speed disc at .050 inches.
	2. Malfunctioned controller.	2. Replace the controller.
System operates when not necessary.	1. Incorrect speedo gear.	1. Replace with correct gear.
Engine backfires	1. A.I.R. bypass system not connected.	1. Connect harness to A.I.R. bypass solenoid.
	2. A.I.R. bypass solenoid not grounded.	2. Attach solenoid to A.I.R. pump with ground screw.
	3. Front wheel sensor improperly positioned.	3. Adjust gap between sensor tip and speed disc to .050".
System Functions at Low Speeds Causing Engine Hesitation	1. Low signal from the front wheel speed sensor (excessive gap between sensor and speed disc).	1. Check and adjust gap between sensor and speed disc at the sensor mounting. Felt spacer should touch the speed disc. If felt spacer is missing, set gap between end of sensor and speed disc at .050".

MAINTENANCE AND ADJUSTMENTS

When the system fails to function properly and the trouble is isolated to a particular portion of the system, the malfunctioned part should be replaced by a new and functioning part.

MAJOR REPAIR

REMOVAL AND INSTALLATION OF MAX-TRAC COMPONENTS

Electronic Controller - less Air Cushion Restraint System

Removal

1. Remove glove box.
2. Remove controller and mounting bracket attaching screws from cowl.
3. Disconnect wiring harness connectors from controller pigtailed and remove controller.
4. Remove controller to mounting bracket attaching screws.

Installation

1. Assemble controller and mounting bracket, making sure the controller ground wire is positioned between the controller and bracket and secured with the right attaching screw and washer.
2. Attach the controller wire connectors to the harness connectors.
3. Attach controller and mounting bracket assembly to cowl.
4. Install glove box.

ELECTRONIC CONTROLLER - WITH AIR CUSHION RESTRAINT SYSTEM

1. Turn ignition switch to "lock" position. Disconnect the negative battery cable from the battery and tape end.
2. Remove lower left cover assembly.
3. Remove controller and mounting bracket attaching screws from lower cover mounting bracket.
4. Disconnect wiring harness connectors from controller pigtailed and remove controller.
5. Remove controller to mounting bracket attaching screws.

Installation

1. Assemble controller and controller mounting bracket.
2. Install the controller mounting bracket to the cover mounting bracket making sure the controller ground wire is secured with the left attaching screw and washer.
3. Connect the controller wire connectors to the harness connectors.
4. Install lower cover assembly.

5. Connect negative battery cable.

"On-Off" Switch**Removal**

1. Remove instrument panel cover.
2. Disconnect "on-off" switch wiring connector.
3. Remove "on-off" switch escutcheon and "on-off" switch by removing two attaching screws.

Installation

1. Install "on-off" switch and escutcheon in instrument panel with two attaching screws.
2. Connect switch wiring connector to harness connector.
3. Install instrument panel cover.

Transmission Speed Sensor**Removal**

1. Disconnect wire connector from speed sensor terminal.
2. Disconnect speedo cable from speed sensor.
3. Remove speed sensor retainer bolt, retainer, and shim sleeve.
4. Pull speed sensor and driven gear out of transmission and have a container ready to receive transmission oil that will drain out.

Installation

1. Assemble speedo driven gear onto speed sensor and install with new "O" ring seal into transmission.
2. Install speed sensor retainer, shim sleeve, and bolt.
3. Connect speedo cable to speed sensor.
4. Attach harness connector to speed sensor terminal.
5. Using transmission filling procedures, check transmission fluid level and add as necessary.

Front Wheel Sensor**Removal**

1. Remove cable attaching screw from rotor shield.

2. Disconnect wire connector from front wheel sensor.
3. Remove wheel sensor retaining bolt and sensor.

of .050" must exist between the tip of the sensor and the speed disc.

2. Connect wire connector to wheel speed sensor terminal.
3. Attach cable retaining clamp to rotor shield.

Installation

1. Install wheel speed sensor with felt tip of sensor against the speed disc attached to the rotor. If the original wheel speed sensor is reinstalled, an air gap

If any of the major components of this system are found to be defective through diagnosis and checking, they are to be replaced, as they are not repairable.

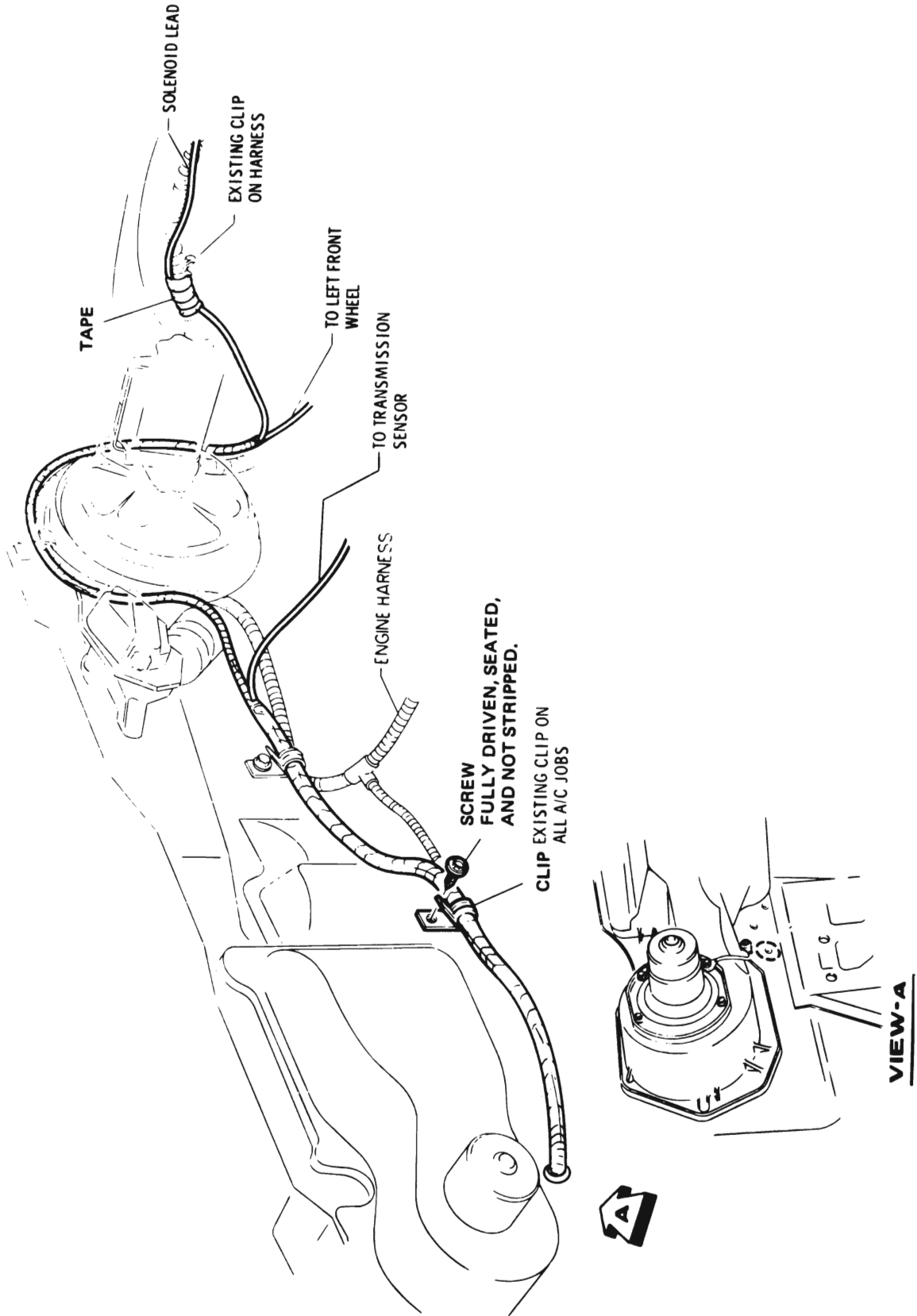

Figure 9D-3 Max-Trac Harness Routing Front of Dash

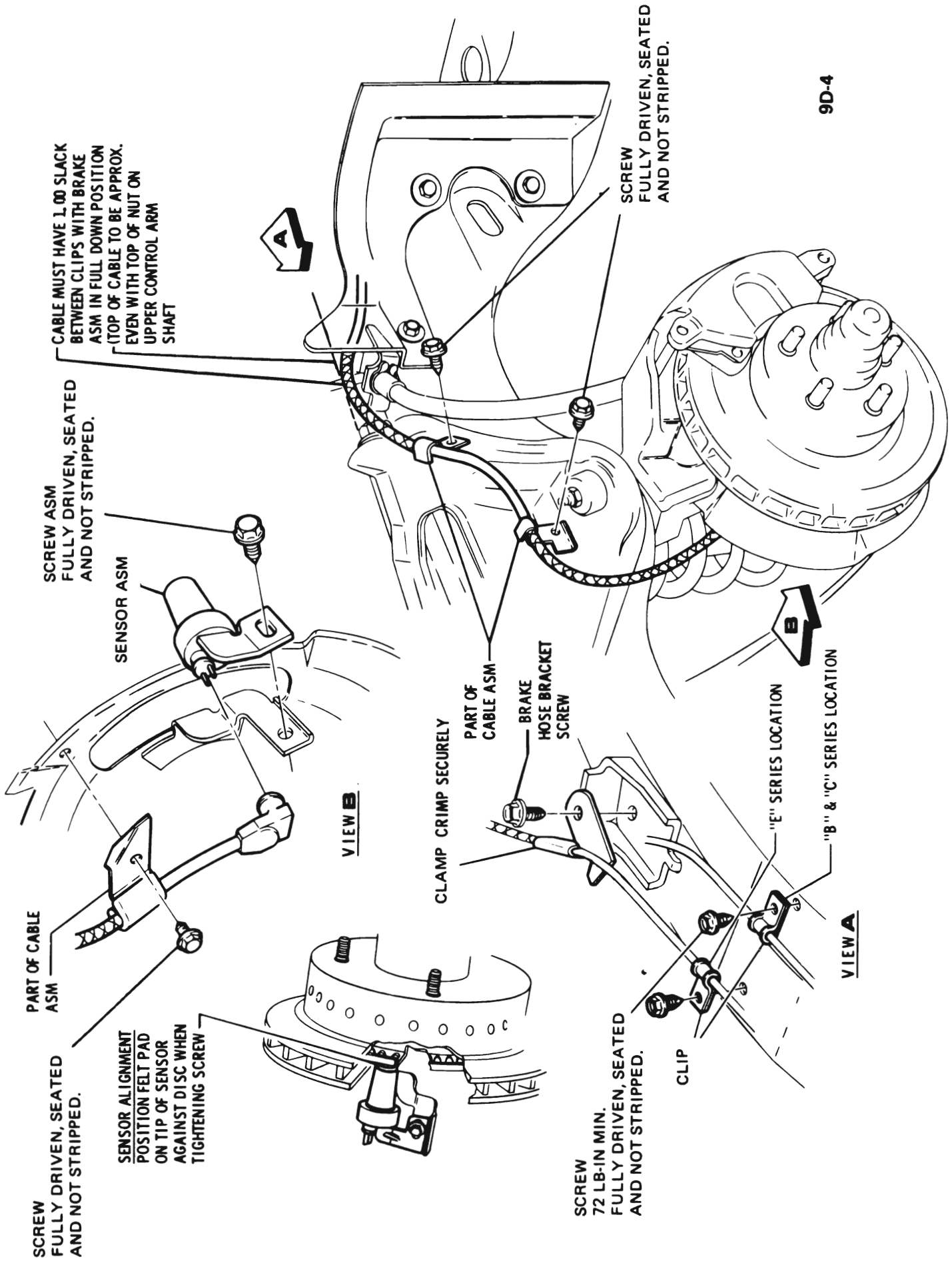

Figure 9D-4 Upper Control Arm and Front Wheel Sensor

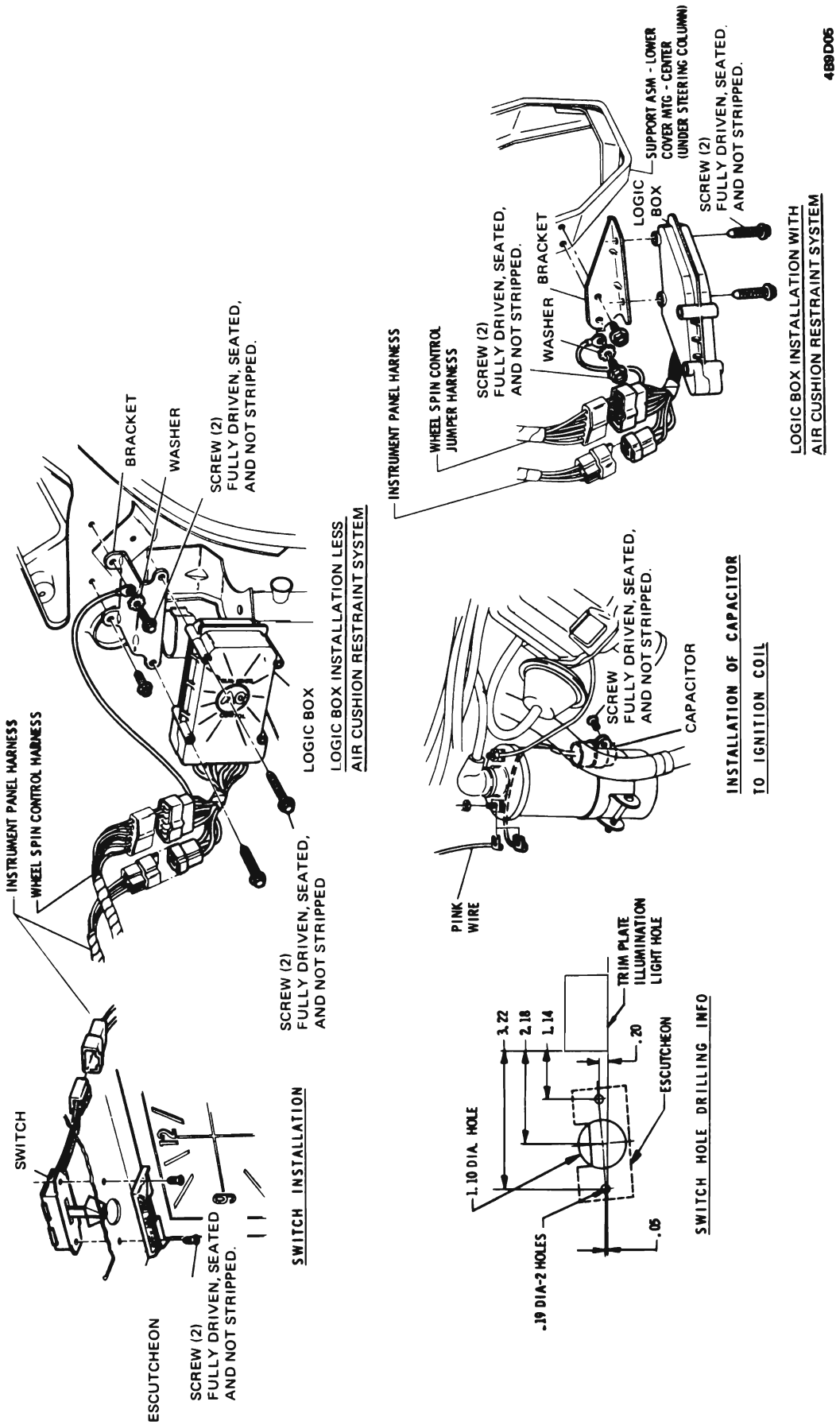

Figure 9D-5 Max-Trac Switch, Capacitor and Logic Box with or less Air Cushion Restraint System

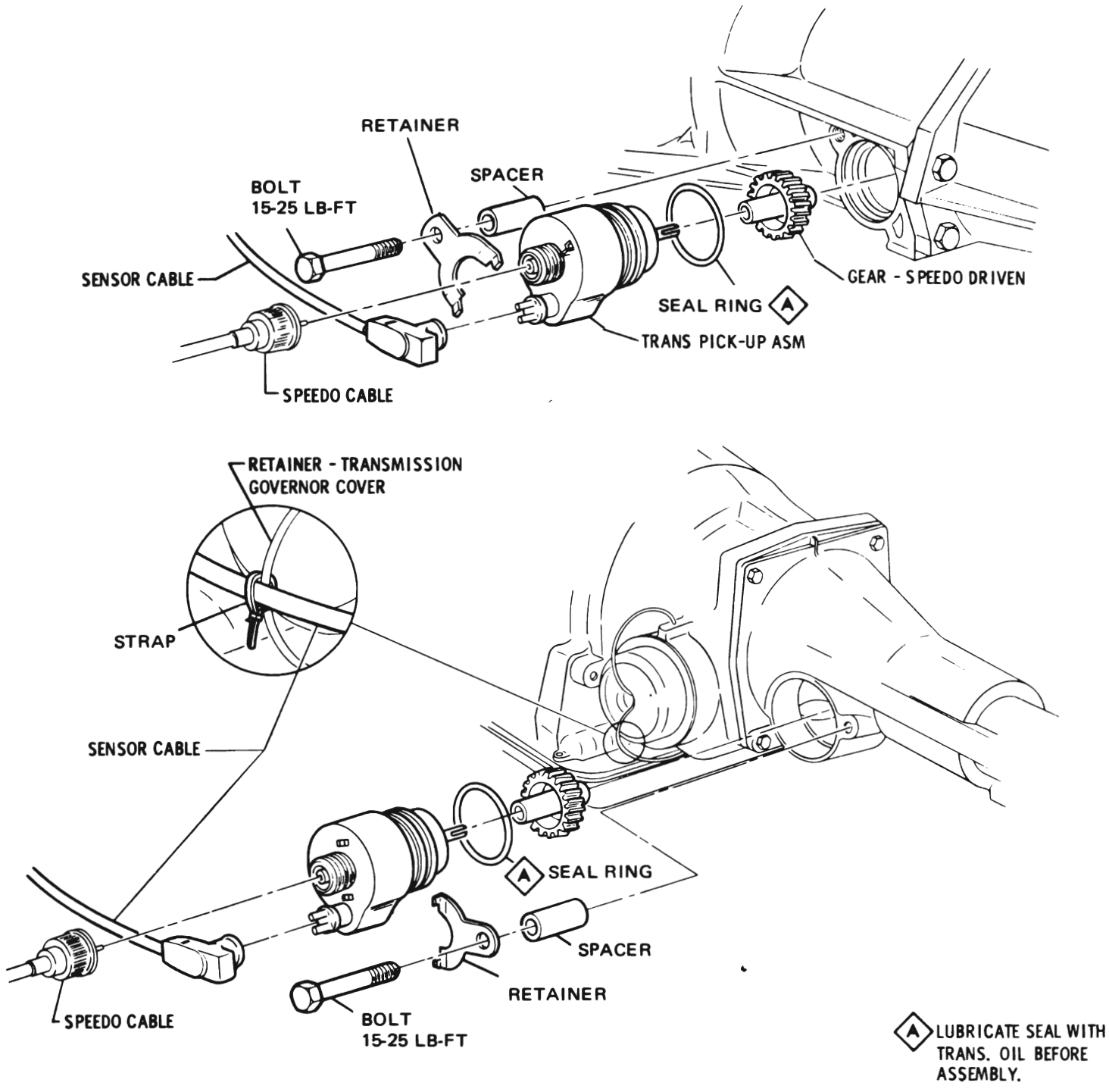
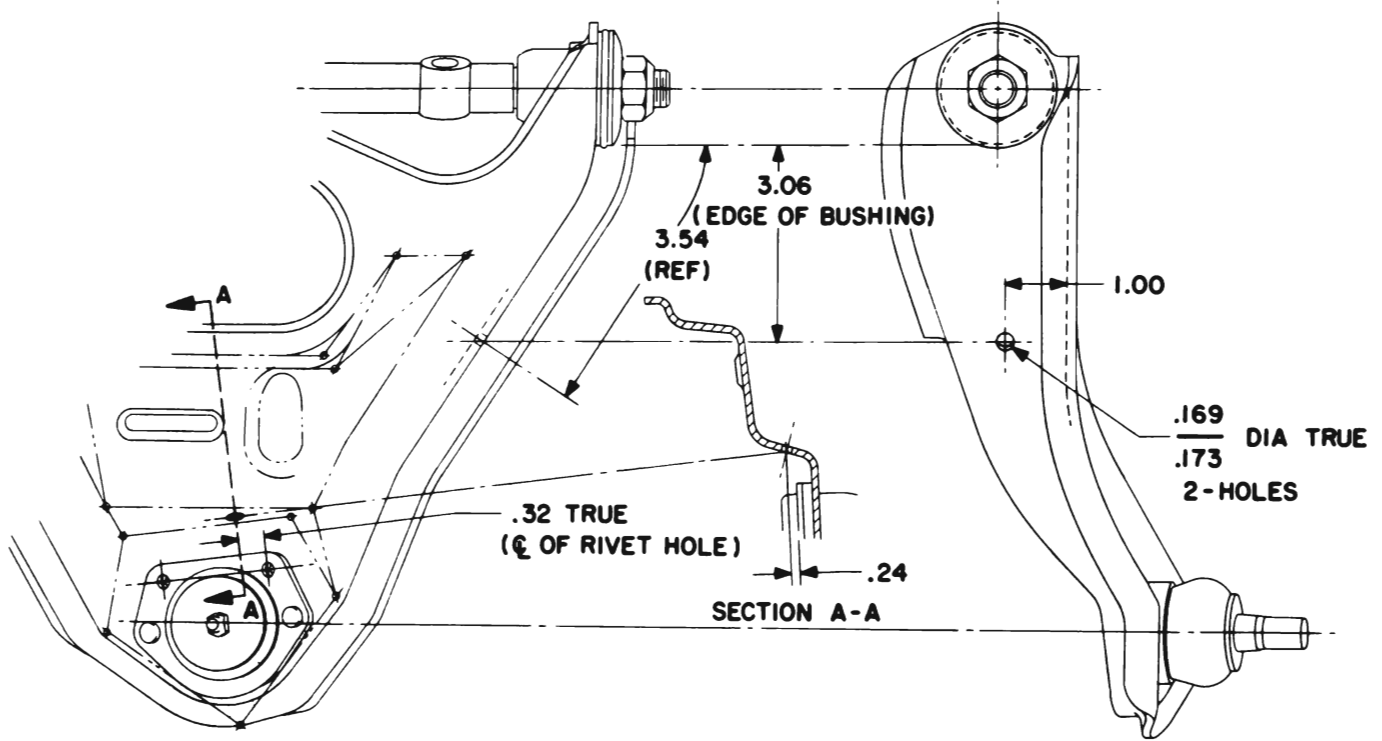
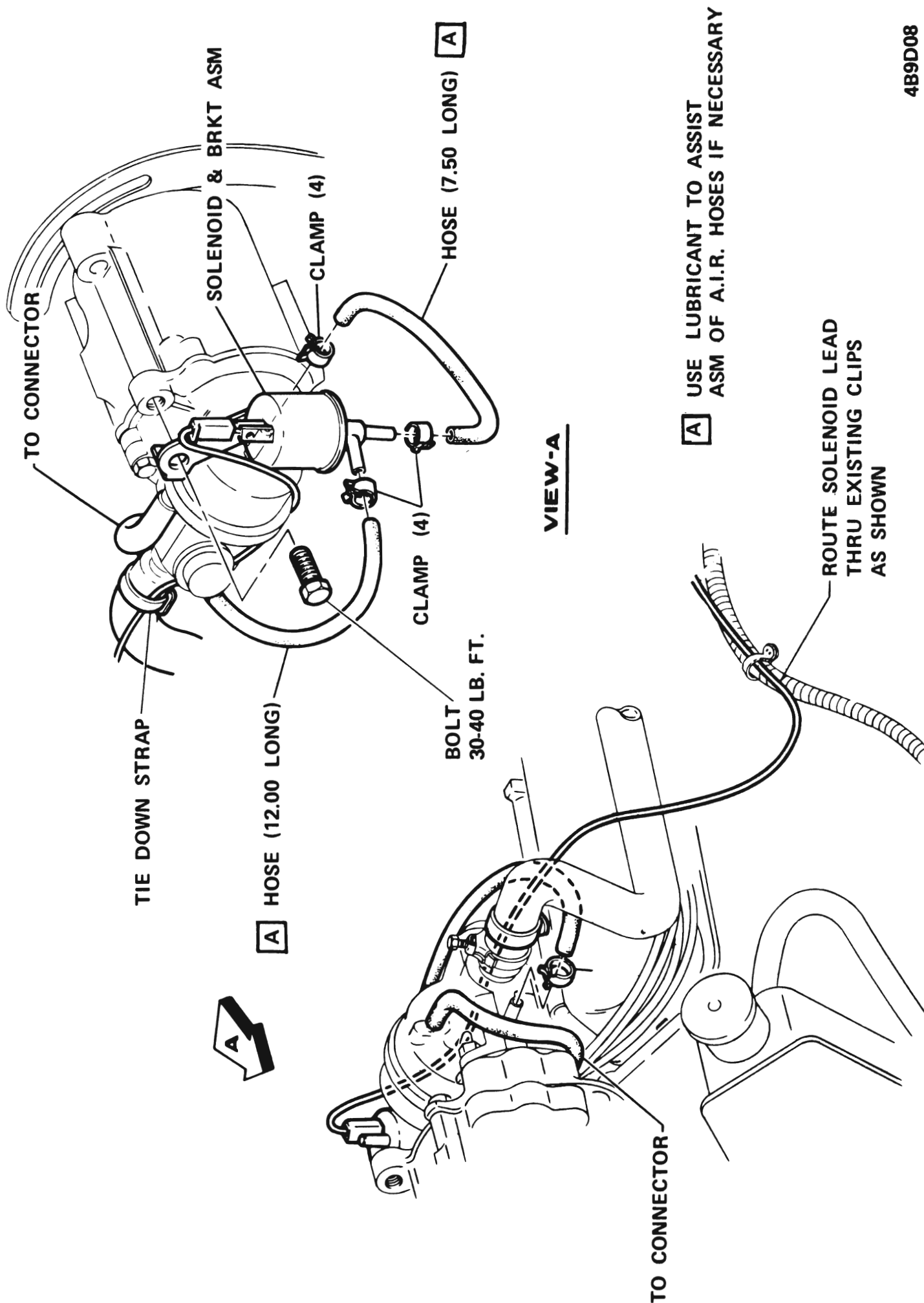

Figure 9D-6 Transmission Sensor



9D-7

Figure 9D-7 Upper Control Arm Drilling Information



4B9D08

Figure 9D-8 A.I.R. Diverter Valve Solenoid

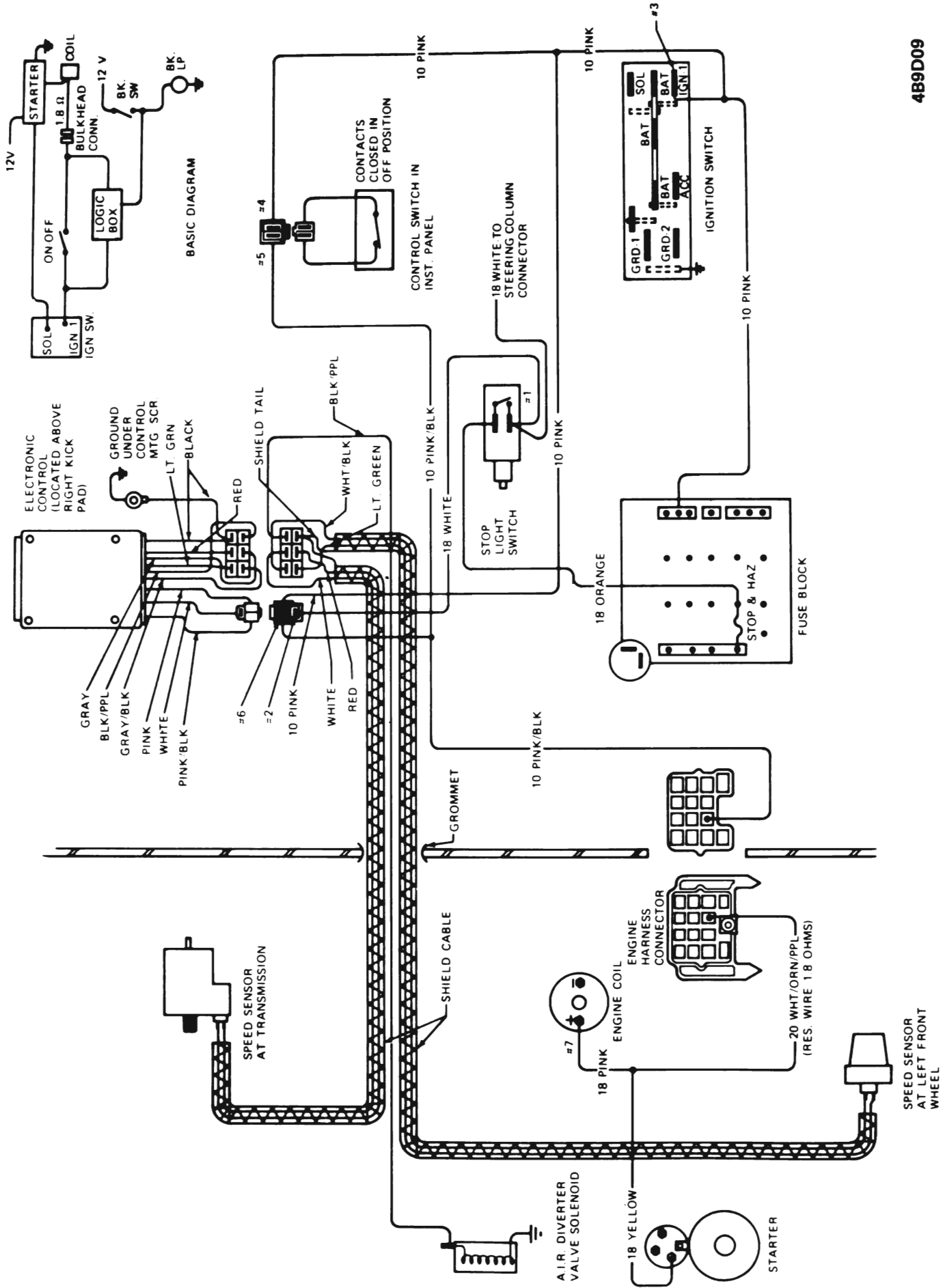

489D09

Figure 9D-10 Max-Trac Wiring Circuit Diagram