

## FENDERS

**WARNING: IF EQUIPPED WITH AIR CUSHION RESTRAINT SYSTEM, DO NOT ATTEMPT ANY ADJUSTMENT, REPAIR OR REMOVAL OF ANY PORTION OF THE CHASSIS SHEET METAL WHICH WOULD REQUIRE REMOVAL OR DISCONNECTING OF THE BUMPER IMPULSE DETECTOR UNTIL THE DISCONNECTION PROCEDURE IS COMPLETED. THIS PROCEDURE MUST BE FOLLOWED TO PREVENT ACCIDENTAL DEPLOYMENT OF THE SYSTEM WHICH COULD RESULT IN PERSONAL INJURY AND/OR DAMAGE TO THE SYSTEM'S COMPONENTS. IN ADDITION, CARE MUST BE EXERCISED TO NEVER BUMP OR STRIKE THE BUMPER IMPULSE DETECTOR IN A MANNER WHICH COULD CAUSE INADVERTENT DEPLOYMENT OR IMPROPER OPERATION OF THE SYSTEM.**

### A.C.R.S. DISCONNECTION PROCEDURE

1. Turn ignition switch to "LOCK" position. Disconnect the negative battery cable from the battery and tape end.

## CONTENTS

Subject	Page No.
<b>DESCRIPTION AND OPERATION:</b>	
Description of Chassis Sheet Metal .....	8B-20
<b>DIAGNOSIS: (Not Applicable)</b>	
<b>MAINTENANCE AND ADJUSTMENTS:</b>	
Fender Adjustments .....	8B-20
<b>MAJOR REPAIR:</b>	
Fender and Wheel House Panel Removal and Installation .....	8B-22
<b>SPECIFICATIONS: (Not Applicable)</b>	

### DESCRIPTION AND OPERATION

#### DESCRIPTION OF CHASSIS SHEET METAL

##### All Series

The front of the assembly is supported by two mounts located at the frame side rails. Shims at these locations allow up and down movement of the front of the sheet metal assembly. Fore and aft and side adjustment is allowed by oversize holes at the fender rear attaching point and chassis sheet metal mounts. Special shims at the rear locations allow adjustment of the rear of the assembly. The lower rear edge of the assembly is attached to the body at the rocker panel by bolts on each side. Shims are used at this location. The bolts that retain the sheet metal braces must be torqued to the required torques. If these bolts are loose, the braces will not provide additional support for the sheet metal assembly.

### MAINTENANCE AND ADJUSTMENTS

#### FENDER ALIGNMENT

It is necessary to analyze the sheet metal as a whole before adjustments are made for best results.

#### Preliminary Tightening

It is advisable to check tightness of all attaching screws and bolts since a true picture of the correction requirements cannot be obtained when the sheet metal is loose and free to shift.

After all parts are properly tightened, inspect fender and hood alignment. Make all inspections before performing any adjustments. An adjustment at one point will usually alter alignment at other points. The preliminary inspection should determine the adjustments that will produce the best overall alignment of hood and fenders at all points. Figure 8B-1.

#### A-B-C-E SERIES

Before making any adjustment of sheet metal to provide necessary clearance, first make sure that front doors are properly aligned in the body openings. If fenders and door panel surfaces are not reasonably flush, realign them. Refer to Figures 8B-2, 8B-3, 8B-4 and 8B-5 for sheet metal aligning tolerances.

#### X SERIES

Doors on X Series have welded hinges and cannot be adjusted.

**SKETCHES SHOWING CAUSES OF UNPARALLELED HOOD LINES**

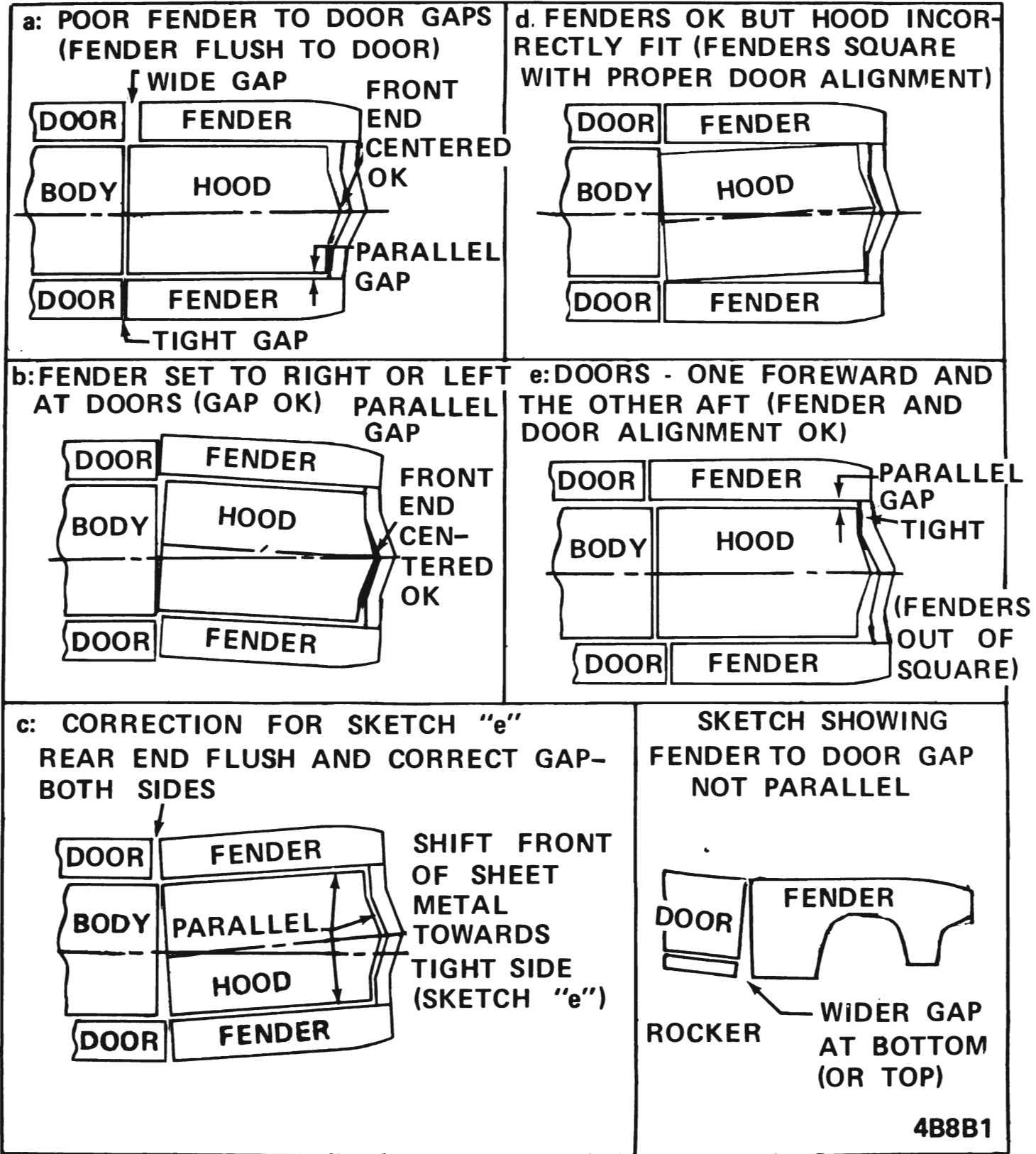

Figure 8B-1 Sheet Metal Alignment

## MAJOR REPAIR

### FENDER AND WHEELHOUSE REMOVAL AND INSTALLATION

#### X Series Fender and Wheel House Removal

1. Disconnect battery ground cable. Remove battery if right side assembly is to be removed.
2. Place vehicle on hoist and remove wheel.
3. Remove hood hinge attaching screws and support hood in open position.
4. Disconnect any bottles, cables or hoses that connect to the wheelhouse, remove battery box if right side is to be removed. Remove fender brace.
5. Disconnect side marker light assembly.
6. Remove bolts securing the front of the fender to the radiator support and front end panel. (Figures 8B-6 and 8B-8)
7. Remove headlamp bezel and headlamp assembly.
8. Remove screws retaining fender and wheelhouse assembly to cowl, radiator support, rocker panel. Note number and location of shims. (Figures 8B-2 and 8B-9)
9. Remove final screws attaching wheelhouse to fender and separate. (Figure 8B-10).

#### Installation

1. Reverse the removal procedure for installation.
2. Guide fender and wheelhouse into position first by inserting the fender in at the bottom adjacent to the door.
3. Install screws at rocker panel and cowl and adjust fender before tightening other screws. Always start adjustment with original amount of shims. (Figure 8B-2).
4. Remove vehicle from hoist.

#### A Series Fender Removal

1. Remove the chrome headlight ring.
2. Remove the 4 fender to radiator support bolts. See Figure 8B-11.
3. Remove the bolt attaching the fender brace rod to front lower edge of fender. See Figure 8B-12.

4. Support the hood in the open position and remove the hood hinge to fender bolts.

5. Remove the 5 fender to body bolts. See Figure 8B-13. Note number and size of shims for reinstallation.

6. Remove the side marker lamp socket by removing the spring clip retaining the lense. See Figure 8B-14.

7. Remove the fender to wheelhouse panel bolts. See Figure 8B-11. (Place protective cloth between fender and bumper.)

8. Remove fender by pushing backwards and up. Protect from contact with door.

#### A Series Fender Installation

1. Place fender in position. Be careful not to damage fender.
2. Reinstall fender to wheelhouse bolts. See Figure 8B-11.
3. Reinstall side marker socket and spring clip. See Figure 8B-14.
4. Install the 5 fender to body bolts and shims. See Figure 8B-13.
5. Install hood hinge.
6. Install fender brace rod. See Figure 8B-4.
7. Install the 4 fender to radiator support bolts. See Figure 8B-11 and install headlight ring.
8. Realign fender if necessary for proper adjustment.

#### A Series Wheelhouse Panel Removal

1. Remove batter for right side removal or canister for left side removal.
2. Remove fender as per fender removal procedure.
3. Remove the battery box attaching bolts and then box. See Figure 8B-15.
4. Remove the wheelhouse to radiator support, and body bolts. See Figure 8A-15.

#### A Series Wheelhouse Panel Installation

1. Install the wheelhouse to radiator support and body bolts. See Figure 8B-15.

2. Install the battery box. See Figure 8B-15.
3. Install fender as per fender installation procedure.
4. Install battery and or canister. Align fender if necessary.

#### **B-C Series Fender and Wheelhouse Removal**

1. Disconnect battery cables and remove battery if battery is on same side as fender being removed.
2. Unfasten all electrical wires attached to wheelhouse.
3. Remove bolts securing battery base to support and wheelhouse. Lift out battery base.
4. Remove bolts securing battery base reinforcement to wheelhouse and radiator support. See Figure 8B-20.
5. Remove bolts securing outer end of radiator support to wheelhouse and fender. See Figure 8B-20.
6. Remove bolts securing front of fender to radiator support, and front end panel. See Figure 8B-20.
7. Remove screws and clip securing fender lower front baffle to frame. See Figure 8B-21.
8. Remove hood hinge to fender bolts supporting hood as outlined in Hood Removal.
9. Remove bolts securing wheelhouse to lower portion of cowl. Note shims. See Figure 8B-20.
10. Remove bolts securing lower rear edge of fender to rocker panel. Note shims. See Figure 8B-22.
11. Remove bolt securing upper rear portion of fender to hinge pillar.
12. Remove bolts securing upper rear portion of fender to upper portion of cowl. Note shims. See Figure 8B-20.
13. Disconnect antenna lead (if so equipped).
14. Remove bolts securing fender to upper tie bar.
15. Rise up and lift off fender and wheelhouse.
16. Wheelhouse can now be removed from fender by removing wheelhouse to fender attaching bolts. See Figure 8B-20.

#### **B-C Series Fender and Wheelhouse Panel Installation**

1. Install wheelhouse to fender and attach with

bolts. See Figure 8B-20.

2. Install bolts, securing fender to upper tie bar.
3. Secure upper rear portion of fender to upper portion of cowl with bolts. See Figure 8B-22.
4. Secure upper rear portion of fender to hinge pillar with bolt.
5. Secure lower rear edge of fender to rocker panel with bolts. See Figure 8B-22.
6. Secure wheelhouse to lower portion of cowl with bolts. See Figure 8B-20.
7. Install 2 hood hinge to fender bolts supporting hood, as per hood hinge installation procedure.
8. Install screws and clip securing fender lower front baffle to frame. See Figure 8B-21.
9. Install bolts securing front of fender to radiator support. See Figure 8B-20.
10. Install bolts securing outer end of radiator support to wheelhouse and fender. See Figure 8B-20.
11. Install bolts securing battery base reinforcement to wheelhouse and radiator support. See Figure 8B-20.
12. Install battery base to support and wheelhouse.
13. Connect all electrical wiring and battery cables. Align fender if necessary.

#### **E Series Fender and Wheelhouse Panel Removal**

1. Disconnect battery cables and remove battery if battery is on same side as fender being removed.
2. Unfasten all electrical wires attached to fender.
3. Remove bolts securing battery base to radiator support and fender wheelhouse. Lift out battery base. See Figure 8B-25.
4. Remove bolt securing bracket to front bumper outer extension.
5. Remove cornering lamp if so equipped.
6. Remove bolts securing lower portion of radiator support to lower front portion of fender. See Figure 8B-26.
7. Remove bolts securing front of fender to radiator support. See Figure 8B-26.

8. Remove screws securing fender lower front baffle. See Figure 8B-27.

9. Remove two hood hinge to fender bolts supporting hood as outlined in Hood Removal.

10. Remove bolts securing skirt to lower portion of cowl. See Figure 8B-25.

11. Remove rocker panel moulding.

12. Remove bolts securing lower rear edge of fender to rocker panel. See Figure 8B-28.

13. Remove bolt securing upper rear portion of fender to bracket at hinge pillar. It is suggested that bracket not be removed from pillar.

14. Remove bolts securing upper rear portion of fender to upper portion of cowl. See Figure 8B-28.

15. Remove bolts securing fender to upper tie bar.

16. Raise up and lift off fender and skirt.

17. Skirt can now be removed from fender by removing skirt to fender attaching bolts. See Figure 8B-19.

#### **E Series Fender and Wheelhouse Panel Installation**

1. Install skirt to fender, securing with bolts. See Figure 8B-26.

2. Install fender to upper tie bar and install bolts.

3. Install bolts, securing upper rear portion of fender to upper portion of cowl. See Figure 8B-28.

4. Install bolt, securing upper rear portion of fender to bracket at hinge pillar.

5. Install bolts, securing lower rear edge of fender to rocker panel. See Figure 8B-18.

6. Install rocker panel moulding.

7. Secure skirt to lower portion of cowl with bolts. See Figure 8B-25.

8. Install hood hinge to fender bolts supporting hood, as outlined in Hood Installation.

9. Install screws, securing fender lower front baffle. See Figure 8B-27.

10. Install bolts, securing front fender to radiator support. See Figure 8B-26.

11. Install bolts, securing lower portion of radiator support to lower front portion of fender.

12. Install cornering lamp, if so equipped.

13. Install bolt, securing bracket to front bumper outer extension.

14. Install battery base and install bolts, securing base to radiator support and fender skirt. See Figure 8B-25.

15. Fasten all electrical wires.

16. Connect battery cables.

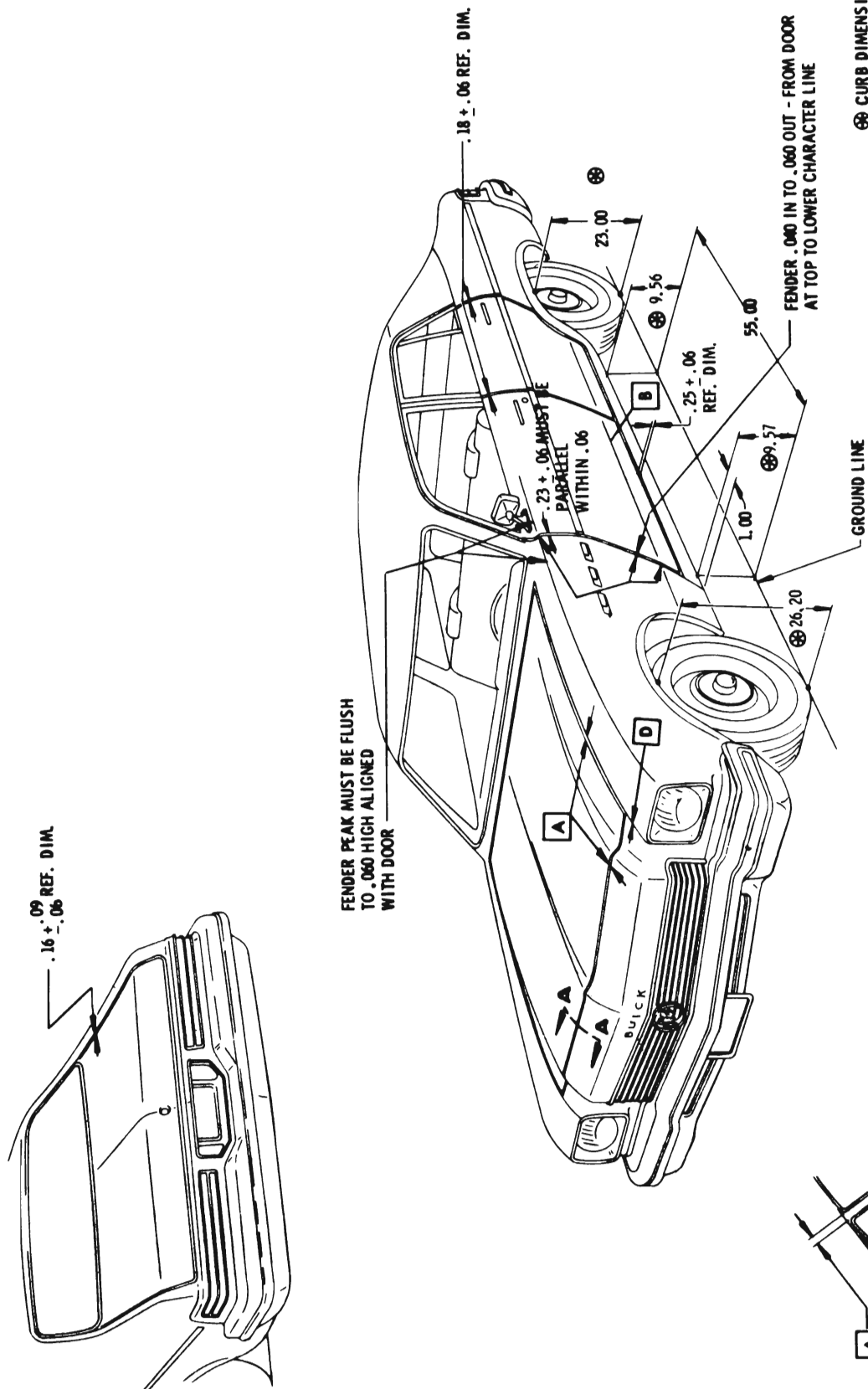

⊕ CURB DIMENSIONS

OVERALL LENGTHS LESS BUMPER & RELATED ATTACHING PARTS.

COUPES & SEDANS 19L 90

488A9

Figure 8B-2 X Series Sheet Metal Dimensions

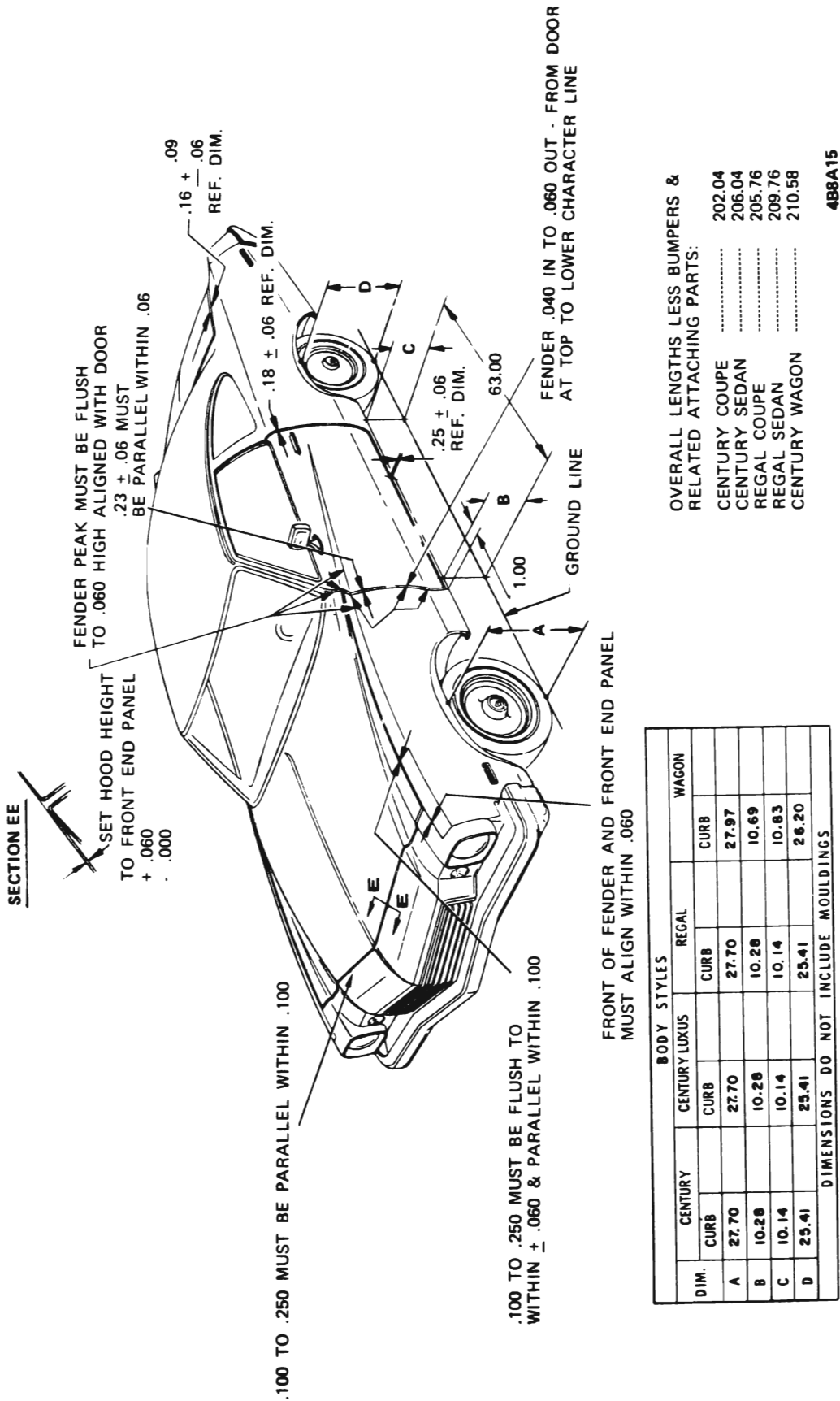
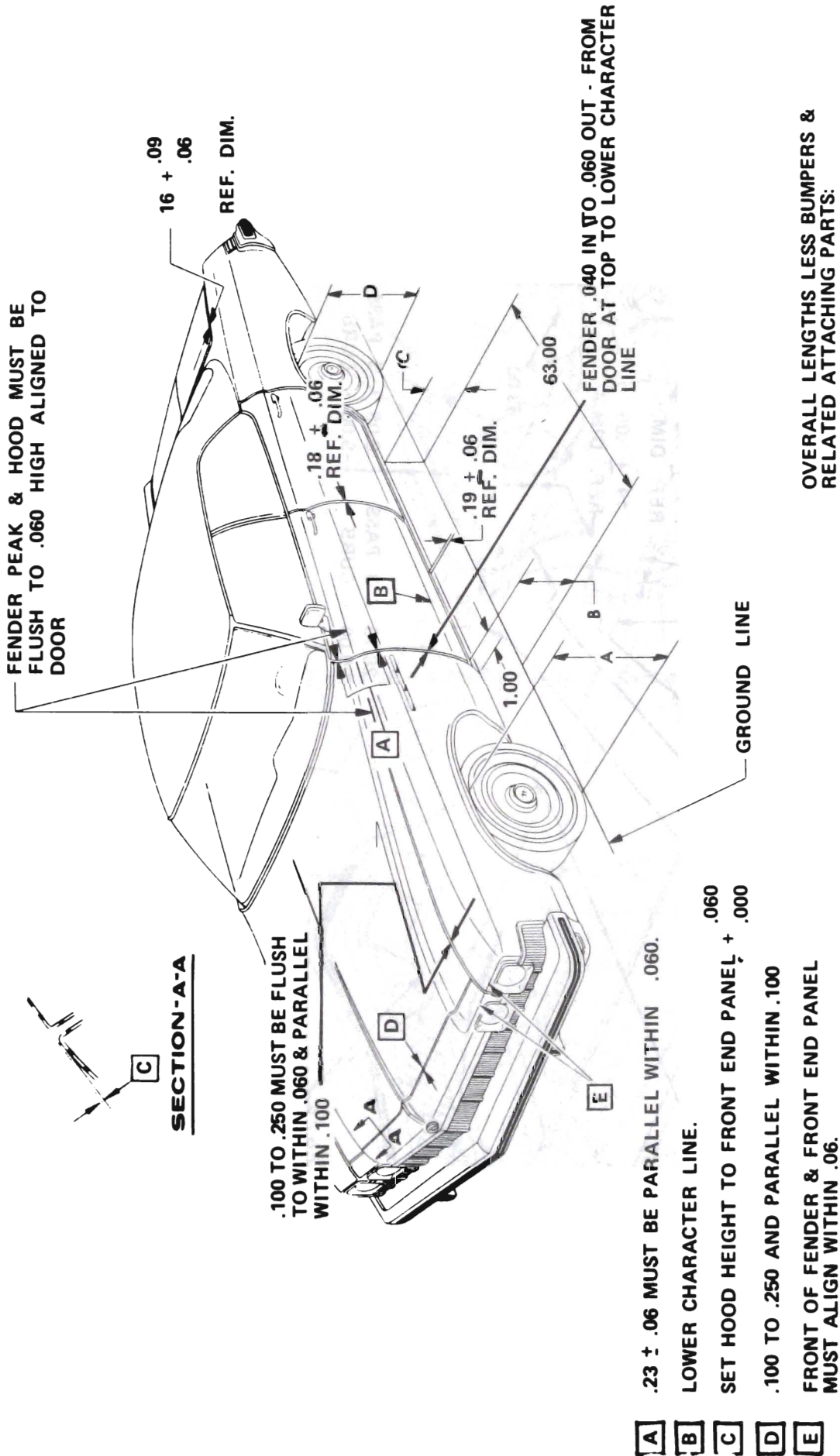

Figure 8B-3 A Series Sheet Metal Dimensions



OVERALL LENGTHS LESS BUMPERS & RELATED ATTACHING PARTS:

LESABRE & LESABRE LUXUS	218.14
ESTATE WAGON	222.18
ELECTRA	222.36

HEIGHTS WITH AUTOMATIC LEVEL CONTROL ARE IDENTICAL TO CURB HEIGHTS.

DIM	LESABRE		ESTATE WAGON		LESABRE LUXUS		ELECTRA	
	CURB		CURB		CURB		CURB	
A	28.48		29.36		28.48		28.62	
B	9.26		10.20		9.26		9.40	
C	9.16		10.21		9.16		9.30	
D	24.32		25.42		24.32		24.30	

DIMENSIONS DO NOT INCLUDE MOULDINGS

488A20

Figure 8B-4 B-C Series Sheet Metal Dimensions



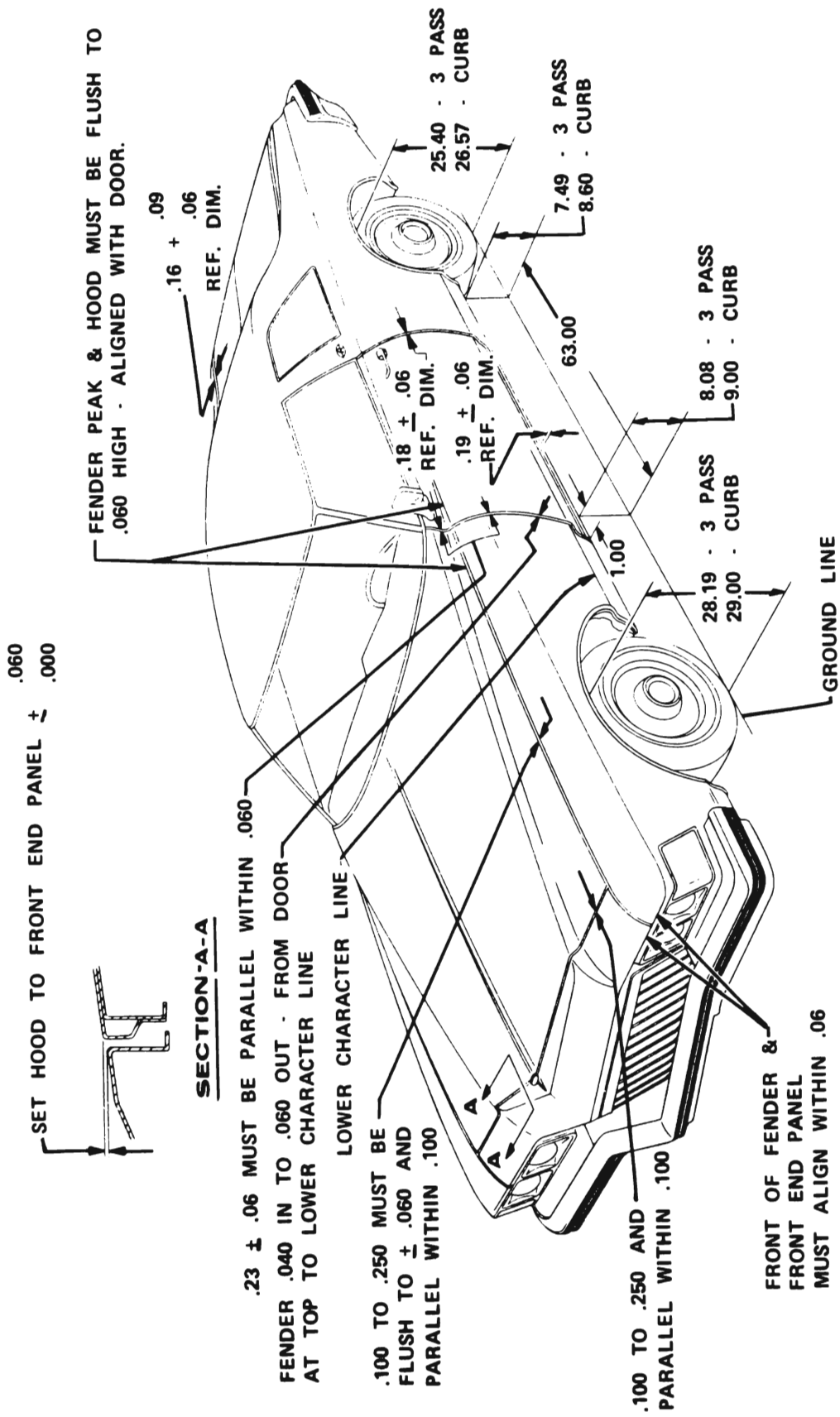

OVERALL LENGTH LESS BUMPERS & RELATED ATTACHING PARTS = 217.86

MOULDINGS NOT INCLUDED IN DIMENSIONS  
HEIGHTS WITH AUTOMATIC LEVEL CONTROL ARE IDENTICAL TO CURB HEIGHTS

488A24

Figure 8B-5 E Series Sheet Metal Dimensions

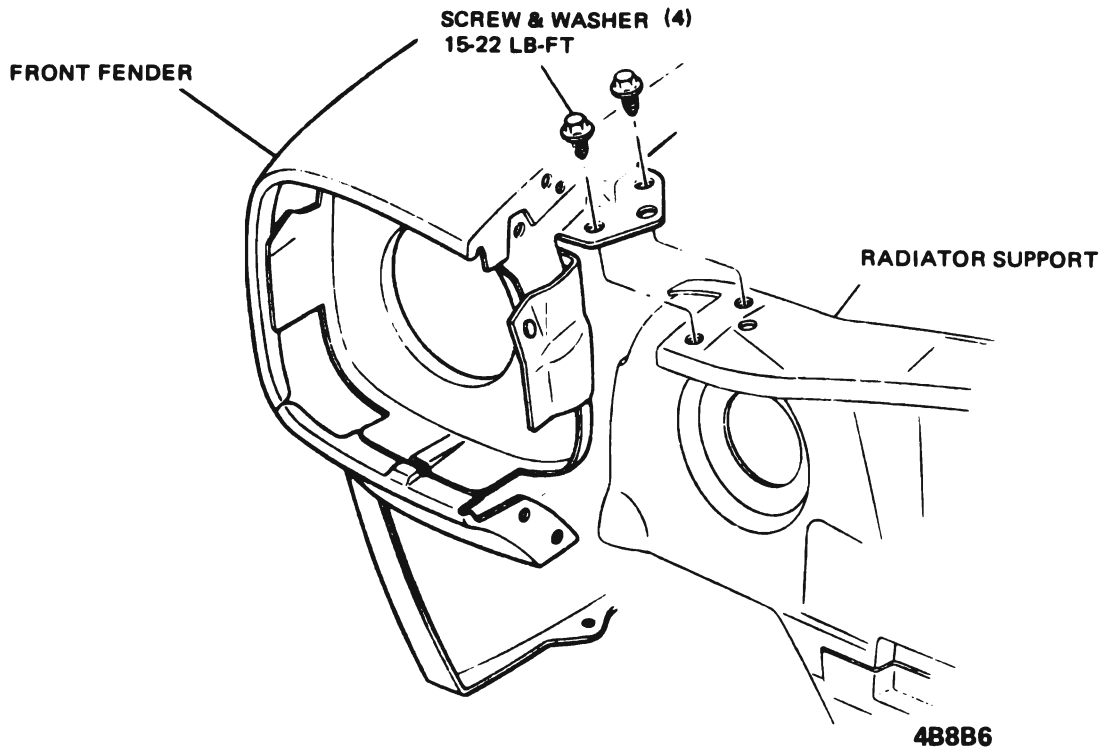

Figure 8B-6 X Series Fender to Radiator Support

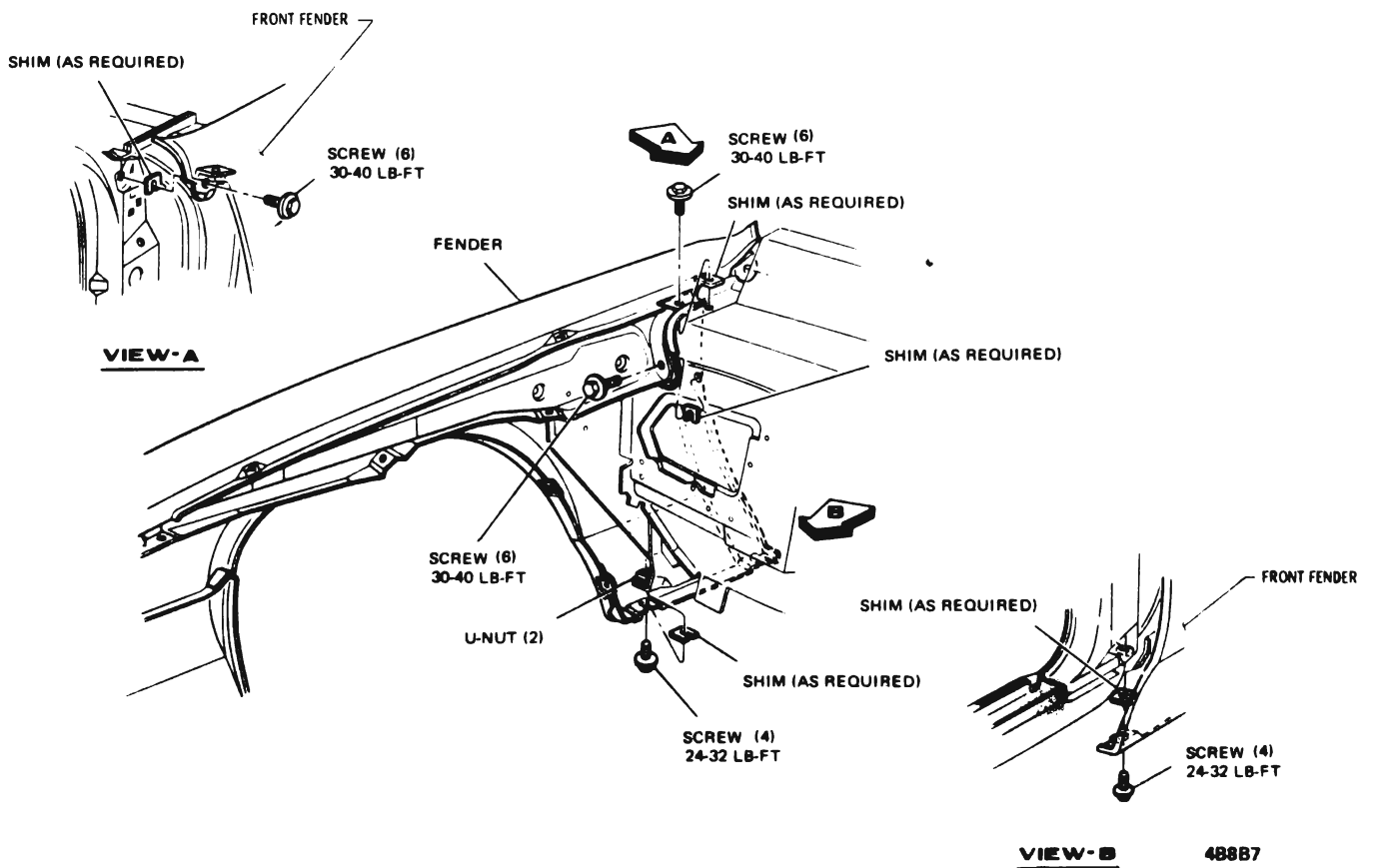

Figure 8B-7 X Series Fender Shim Locations

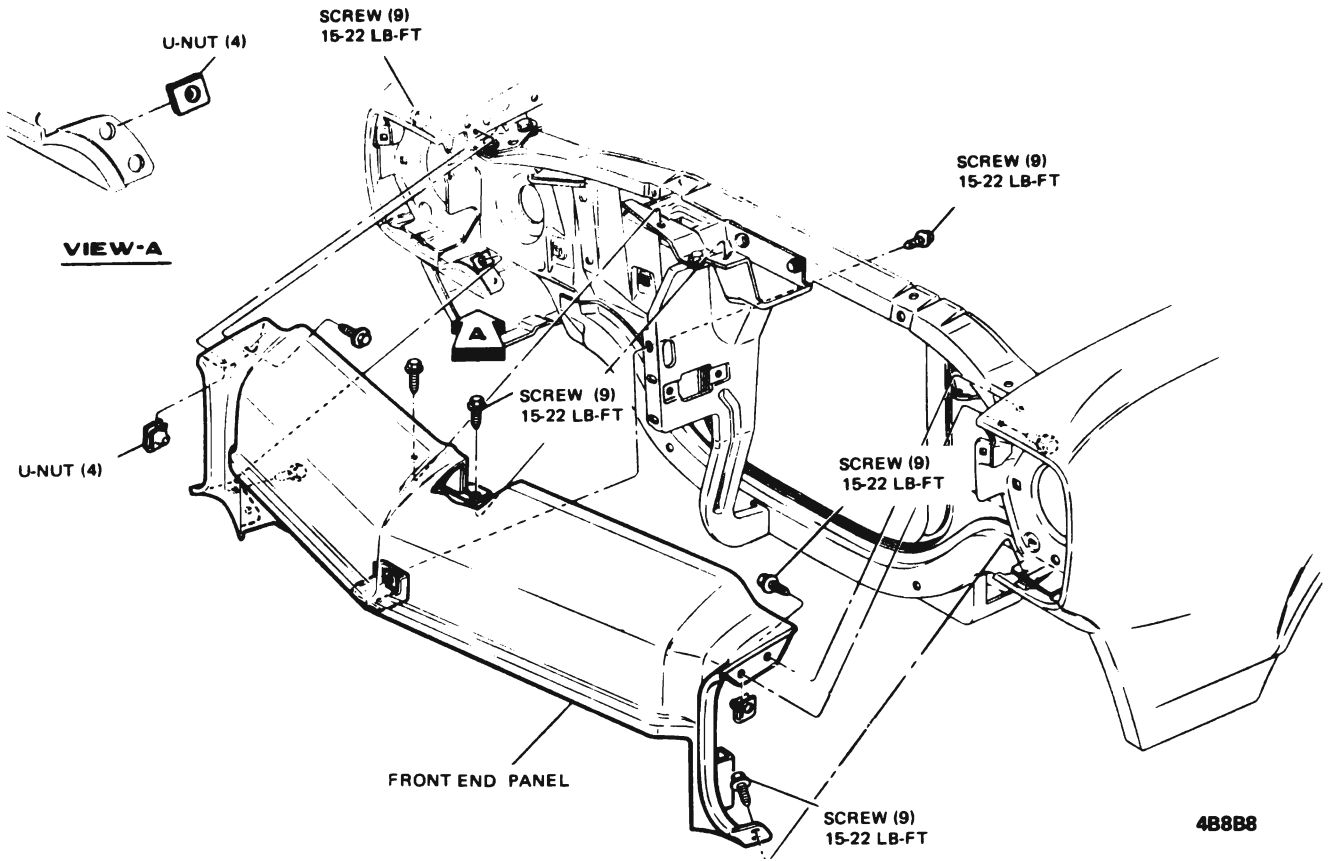

Figure 8B-8 X Series Fender to Front End Panel

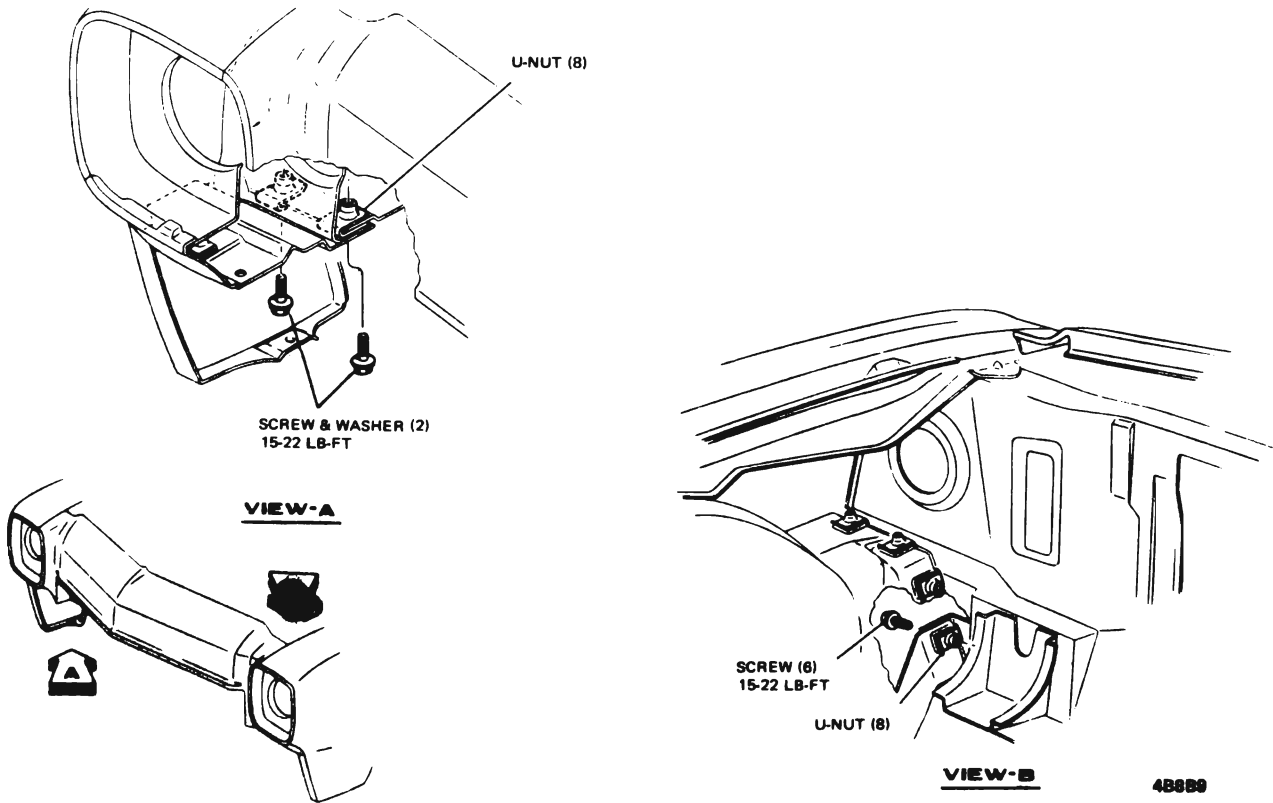

Figure 8B-9 X Series Wheelhouse to Radiator Support

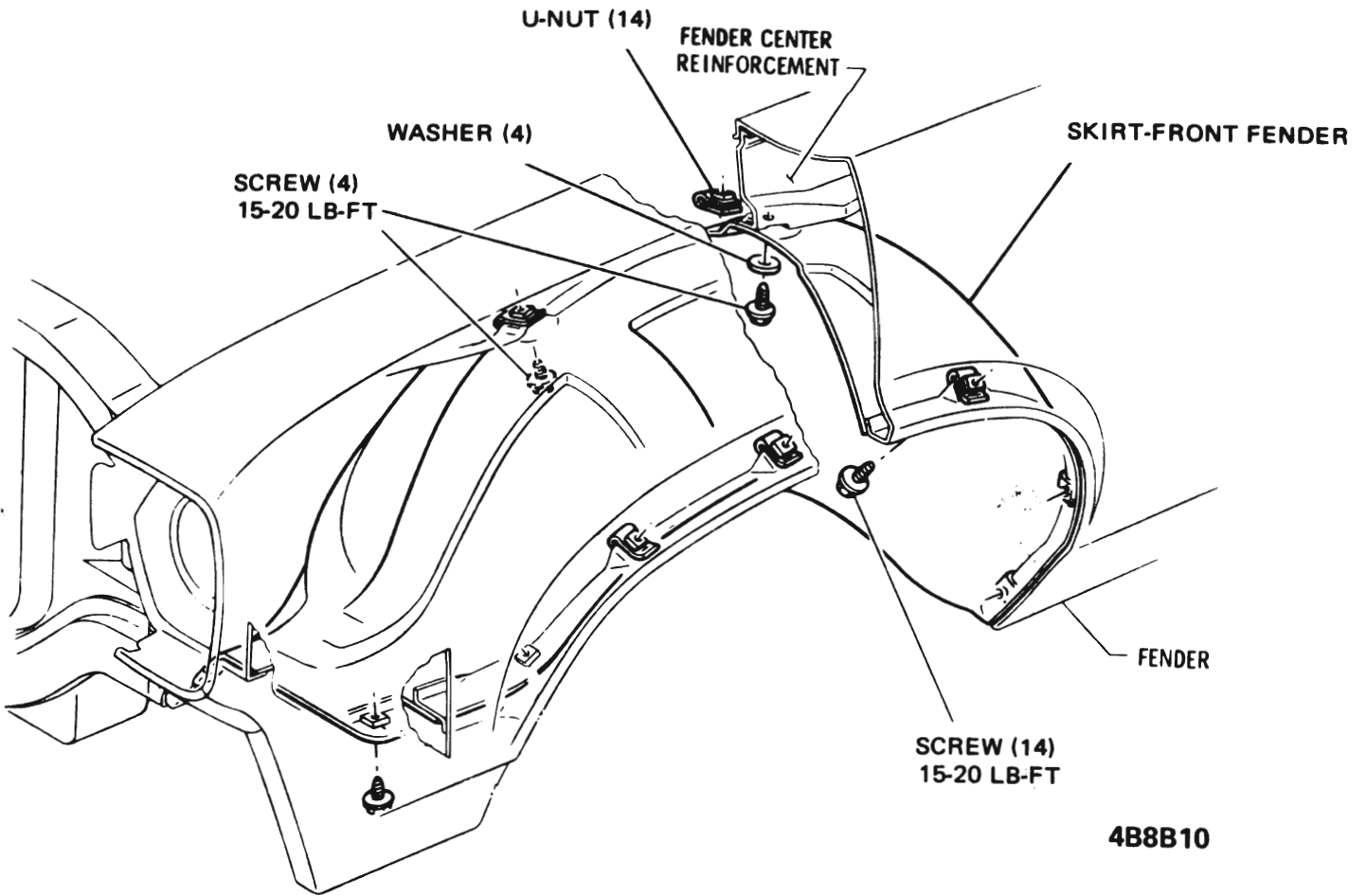

Figure 8B-10 X Series Wheelhouse to Fender

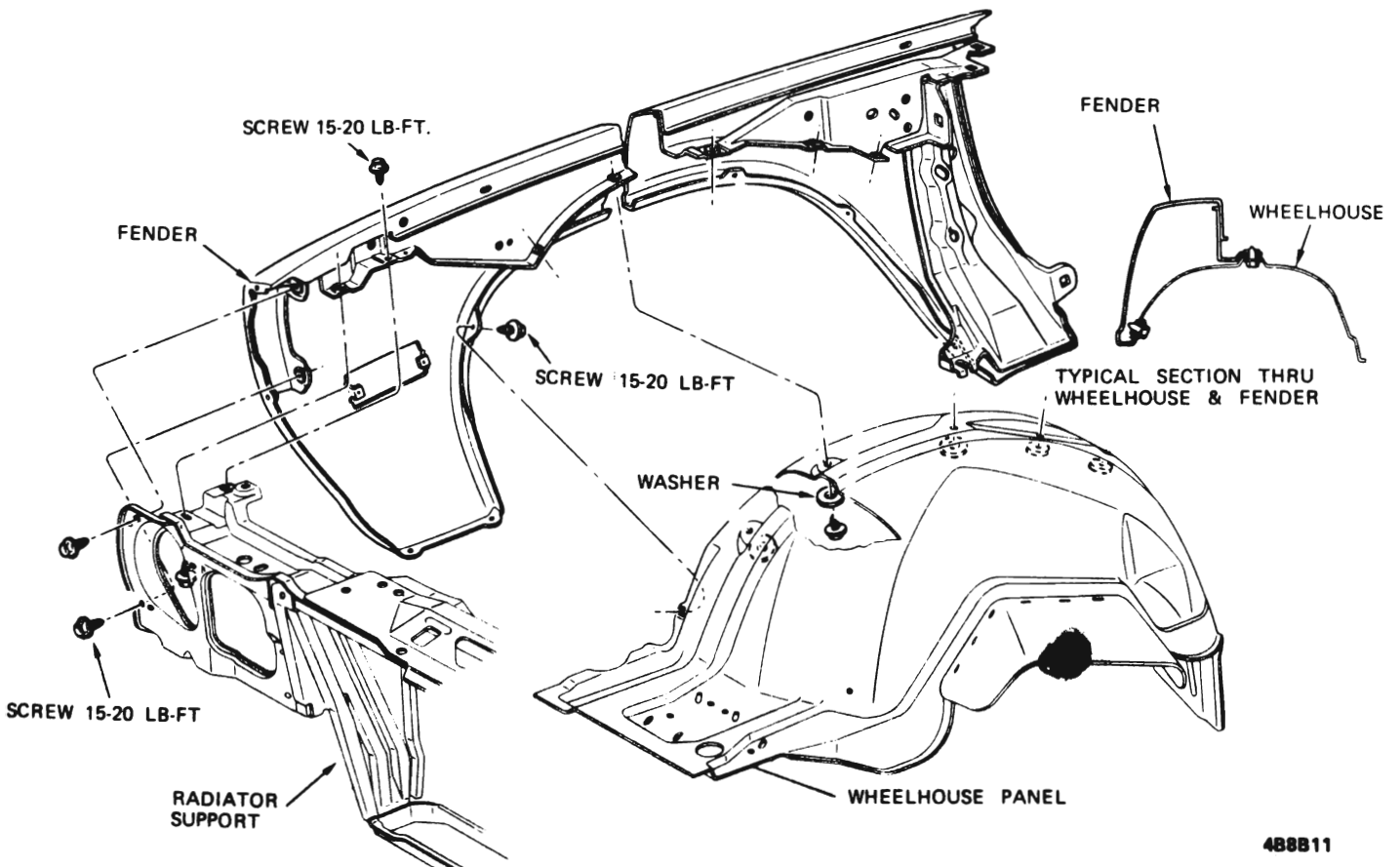

Figure 8B-11 A Series Fender to Radiator Support Mounting

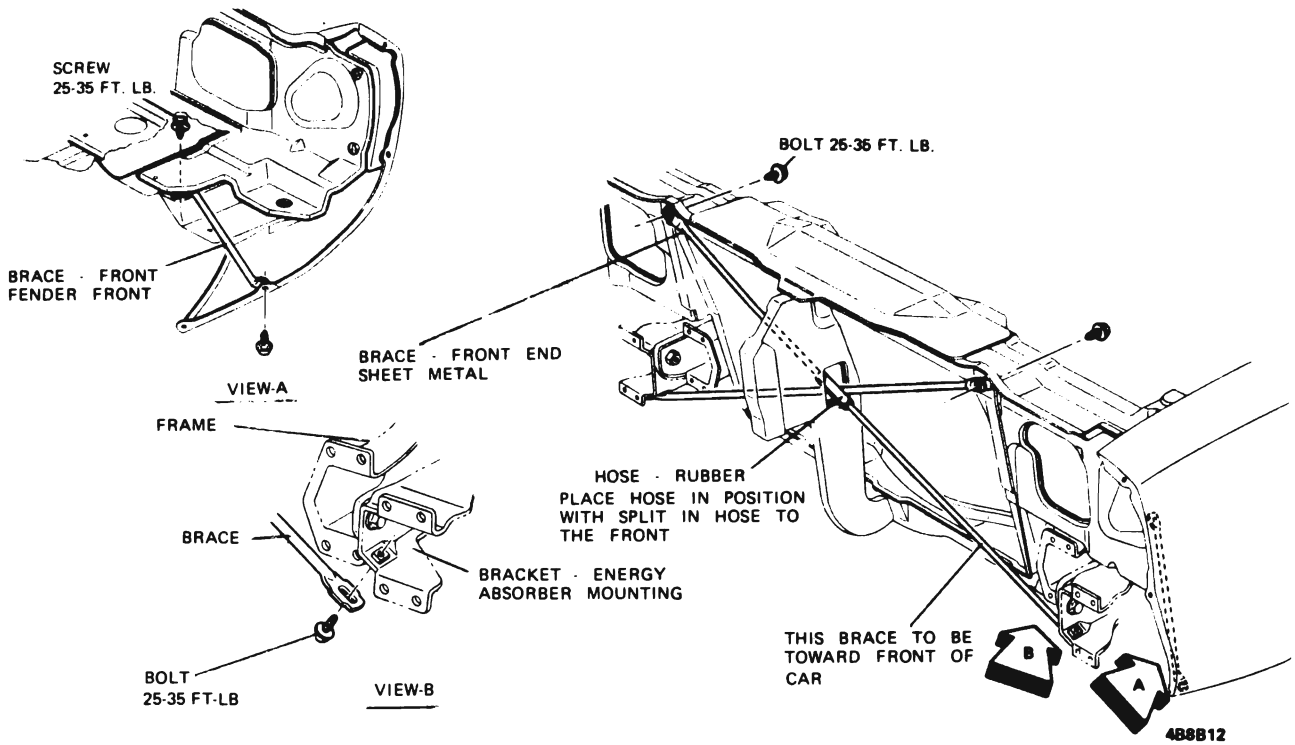

Figure 8B-12 A Series Fender Brace and Front Sheet Metal

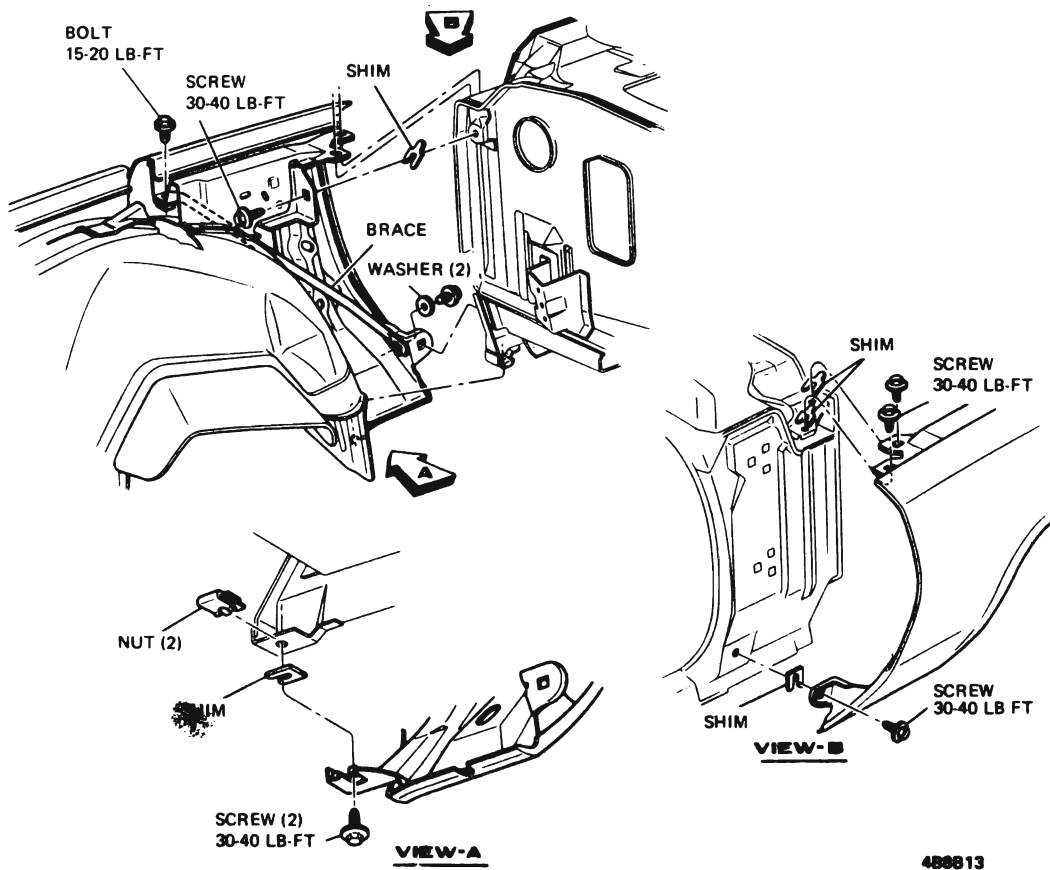

Figure 8B-13 A Series Fender to Body Mounting

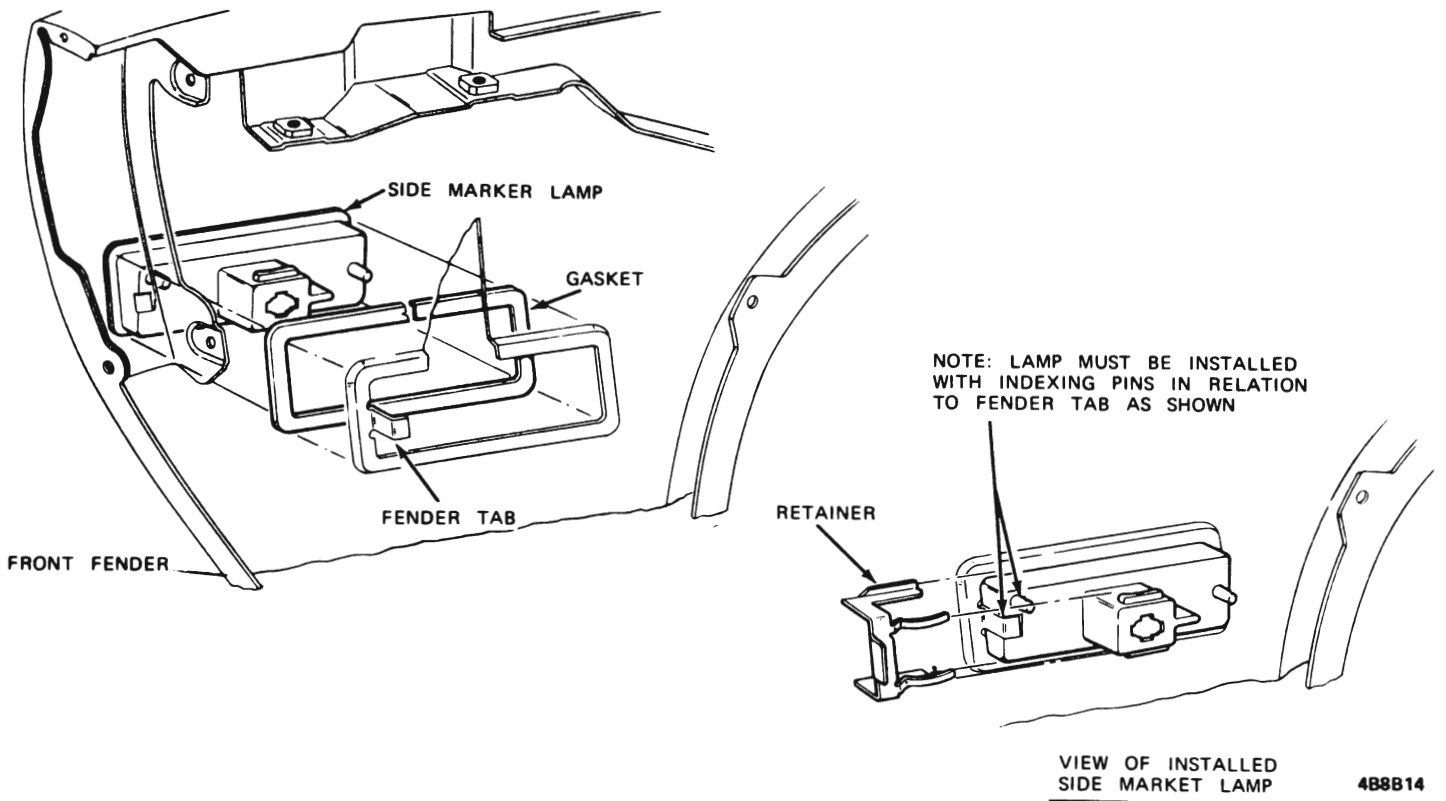

Figure 8B-14 A Series Side Marker Lamp

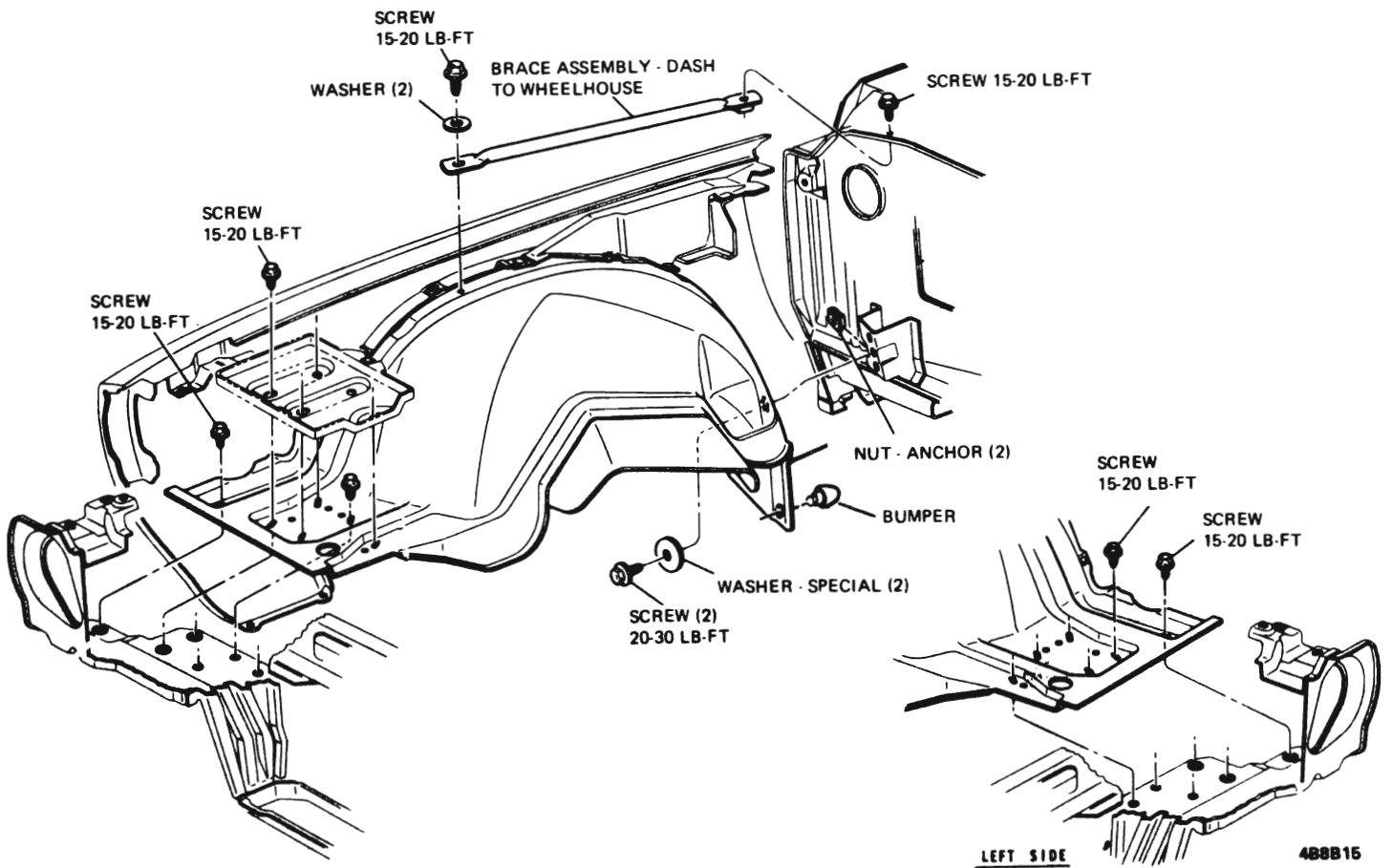

Figure 8B-15 A Series Wheelhouse Mounting

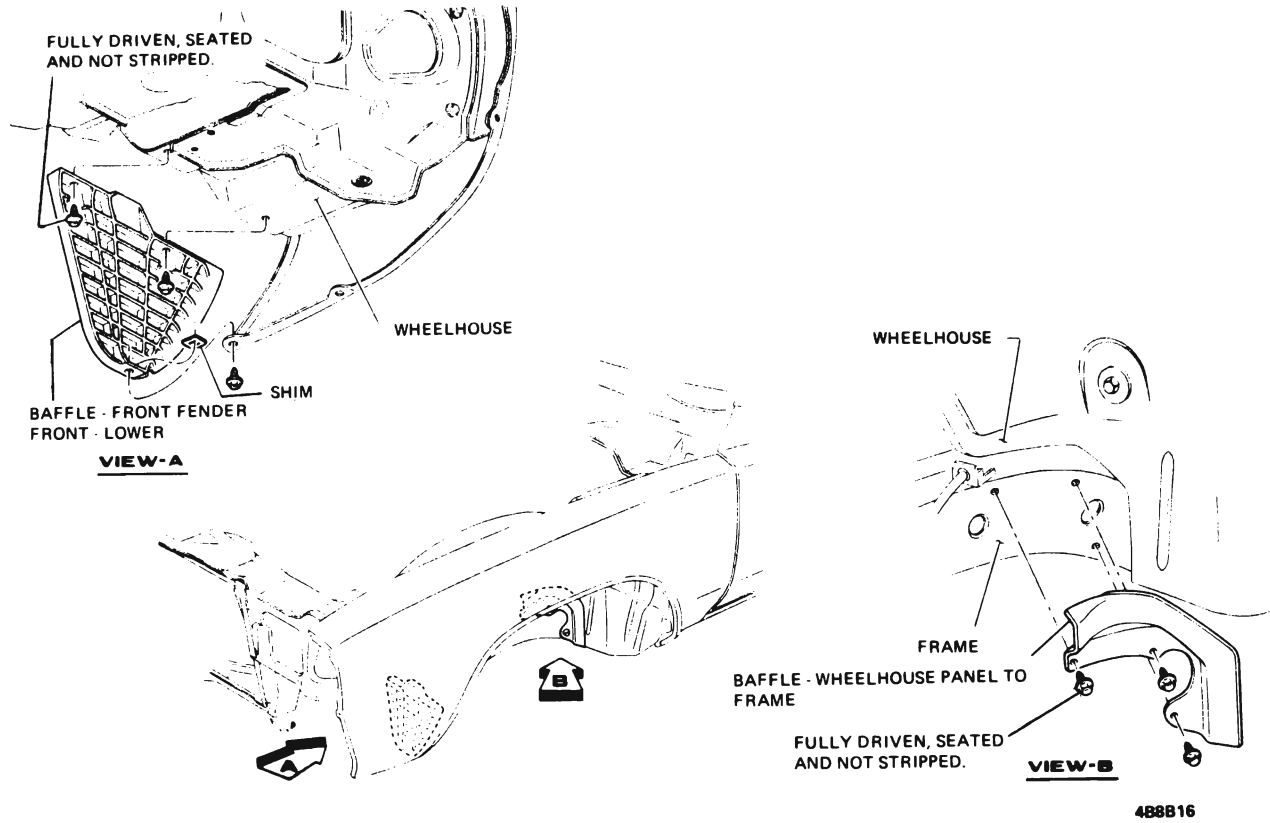

Figure 8B-16 A Series Front Baffle

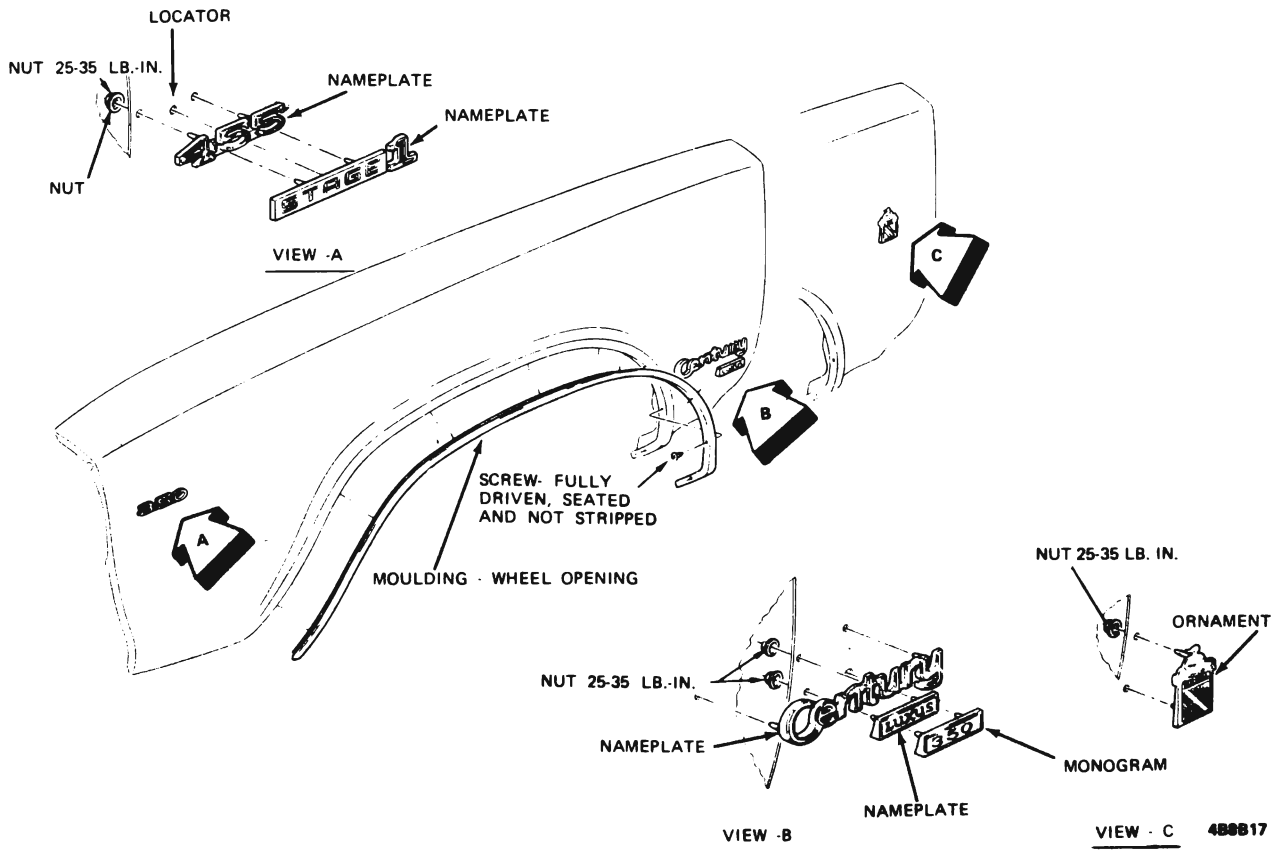

Figure 8B-17 A Series Fender Ornamentation

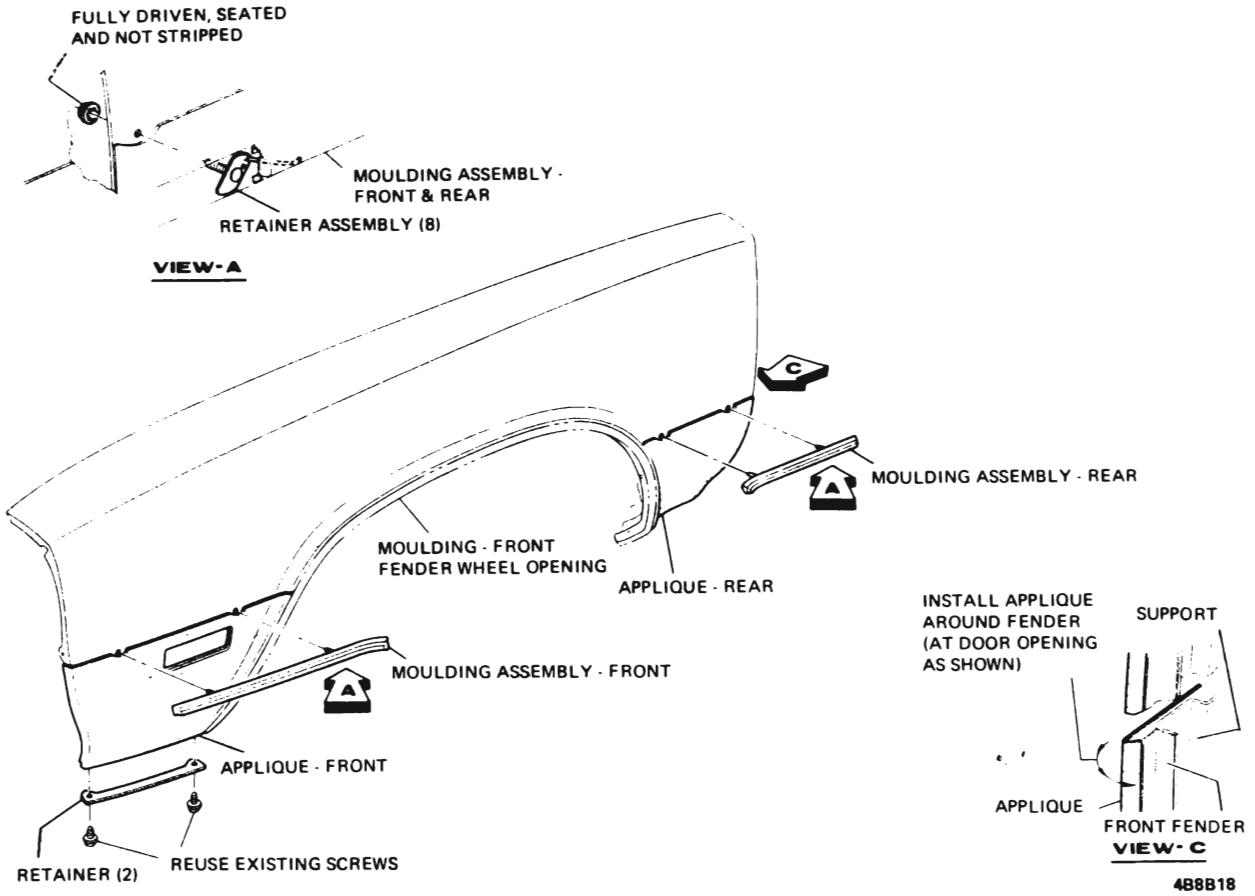

Figure 8B-18 A Series Wagon Fender Ornamentation

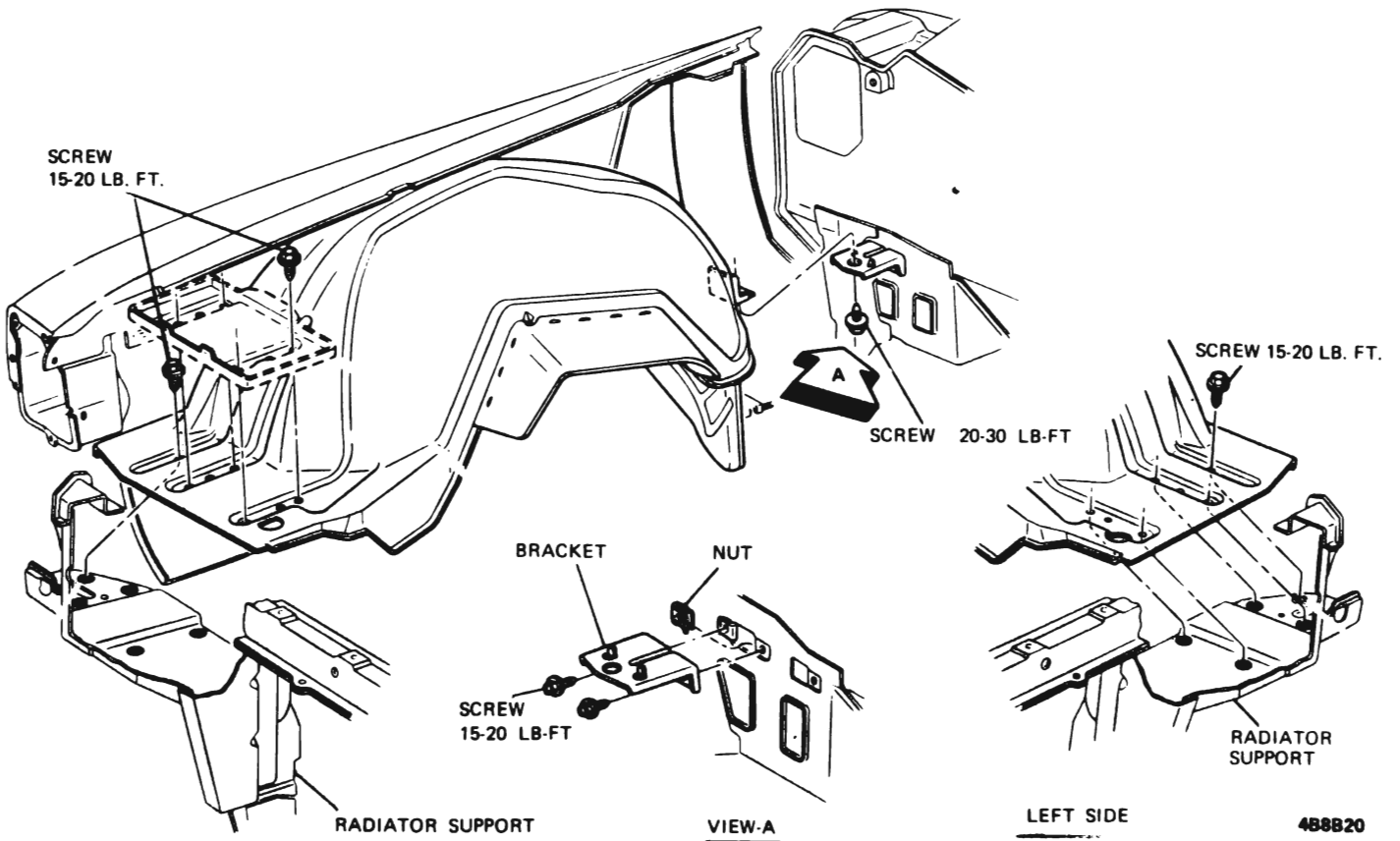

Figure 8B-20 B-C Series Wheelhouse Mounting



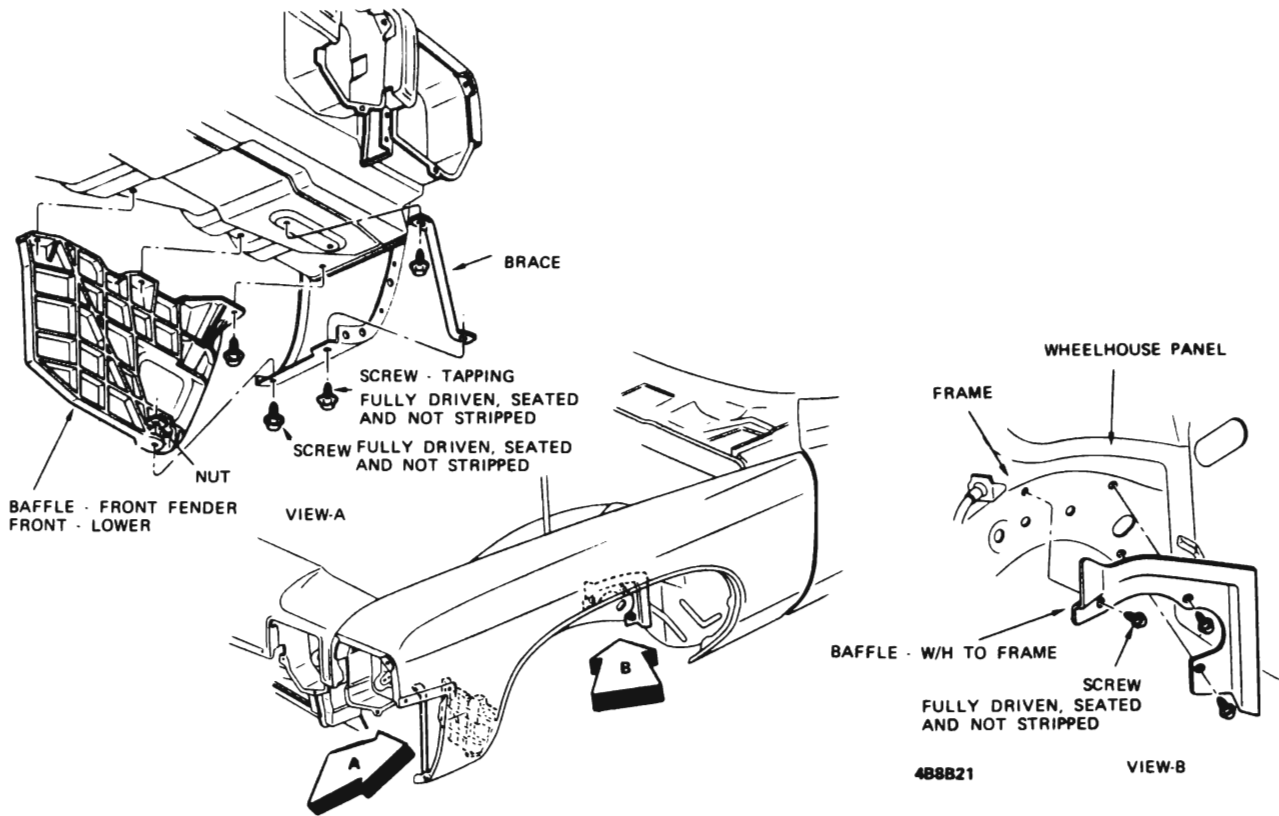

Figure 8B-21 B-C Series Baffle

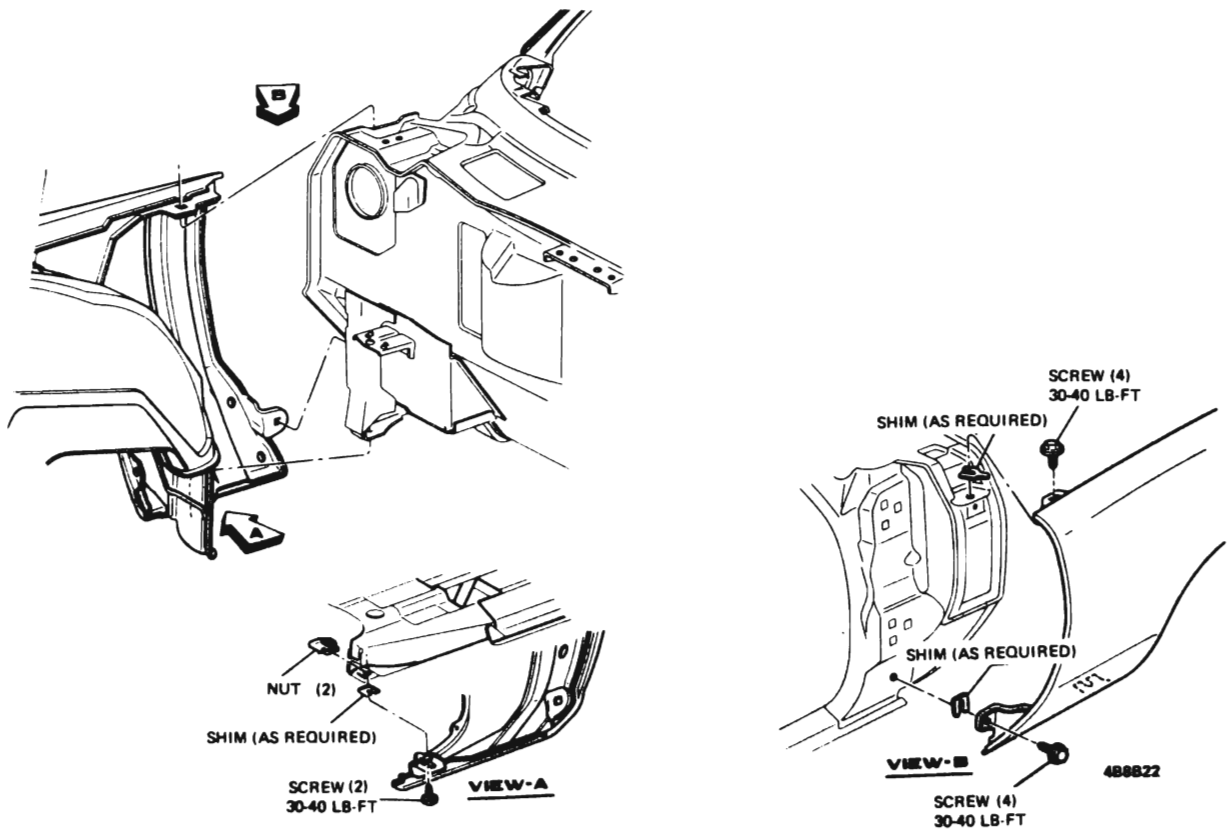

Figure 8B-22 B-C Series Fender to Body Mounting

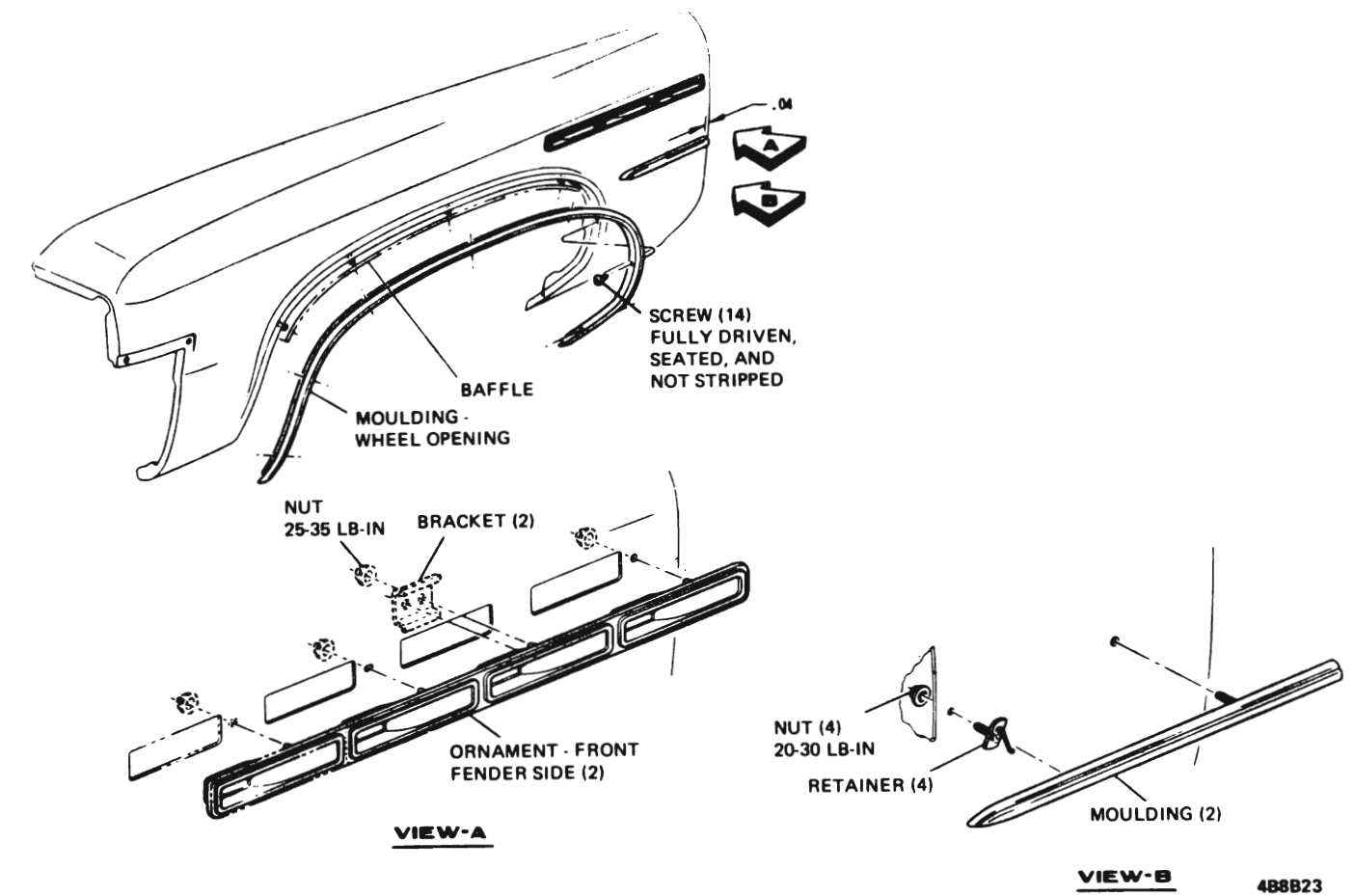

Figure 8B-23 B-C Series Fender Ornamentation

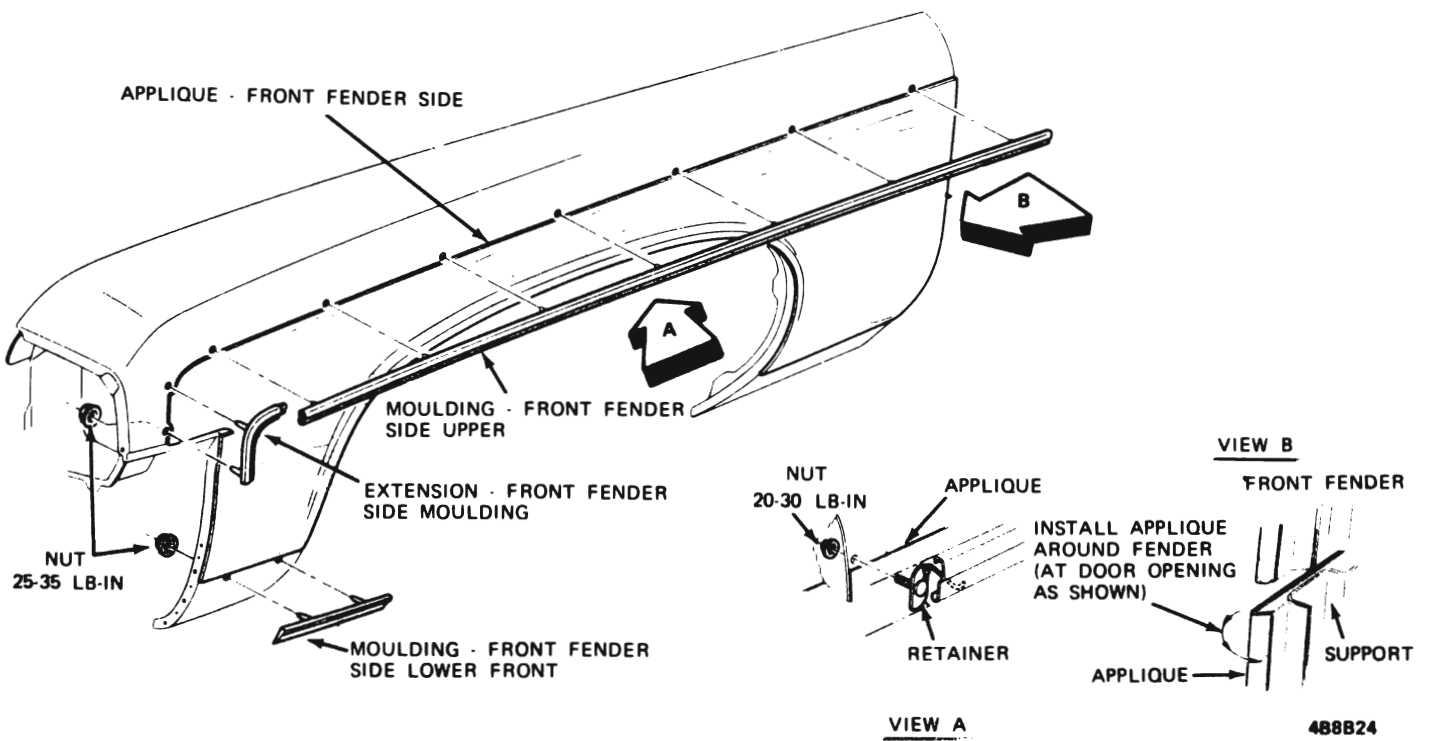

Figure 8B-24 B Series Wagon Fender Ornamentation

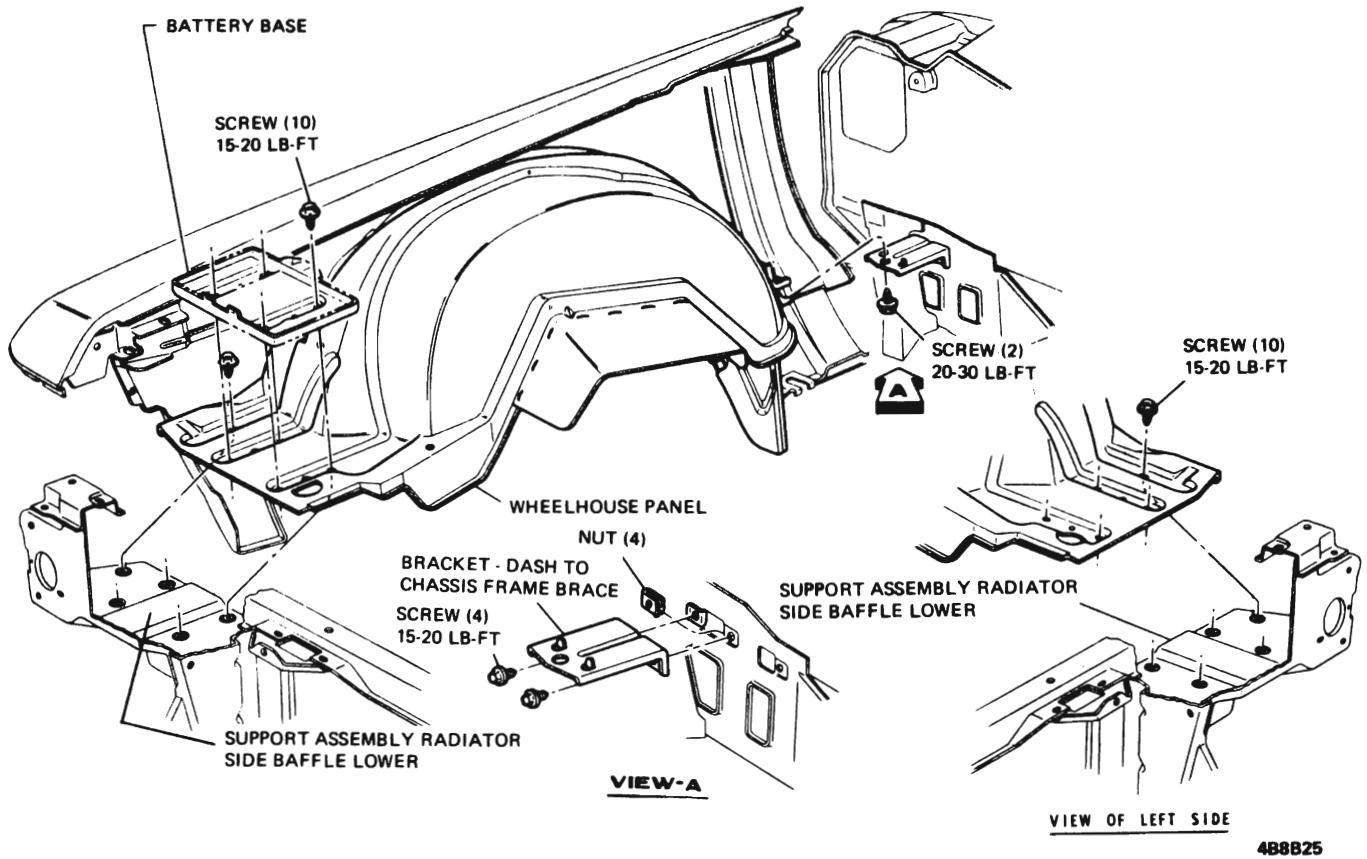

Figure 8B-25 E Series Wheelhouse Mounting

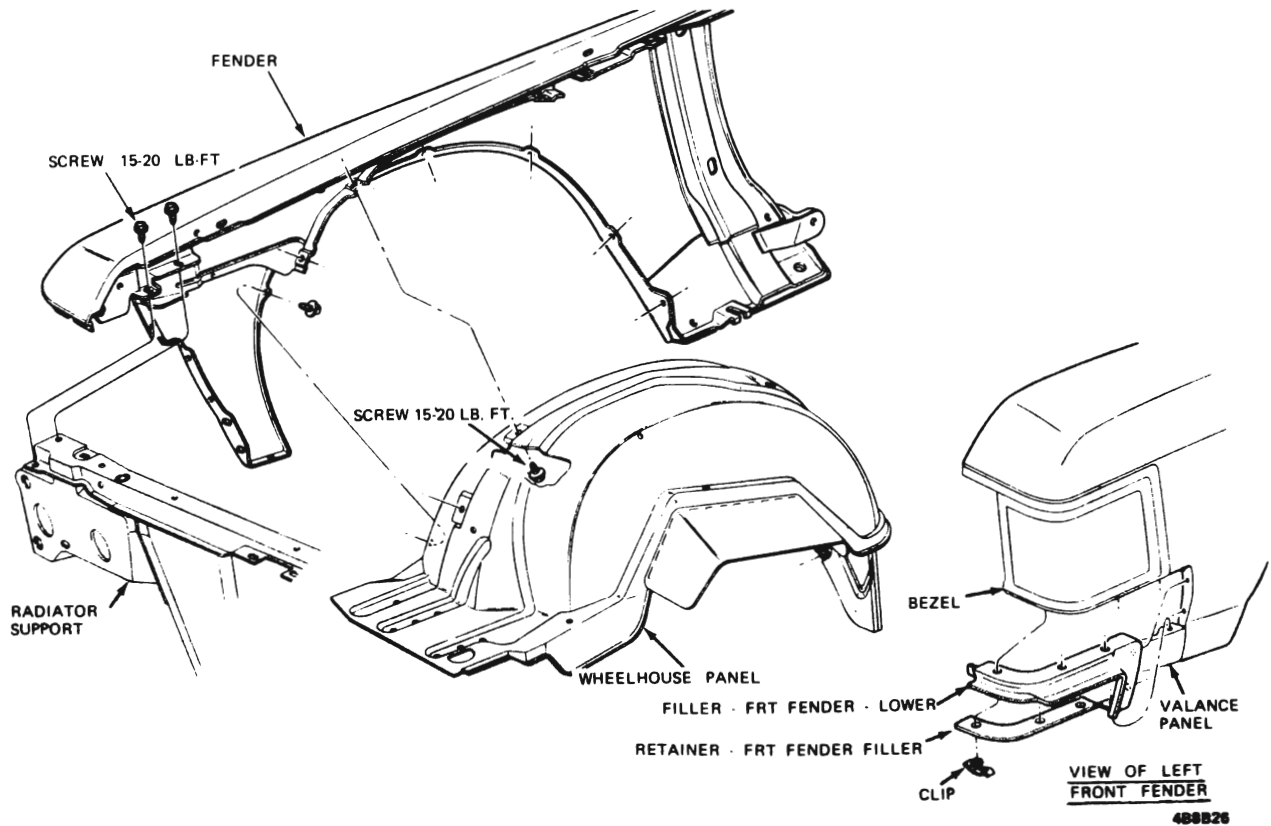

Figure 8B-26 E Series Fender and Wheelhouse Installation

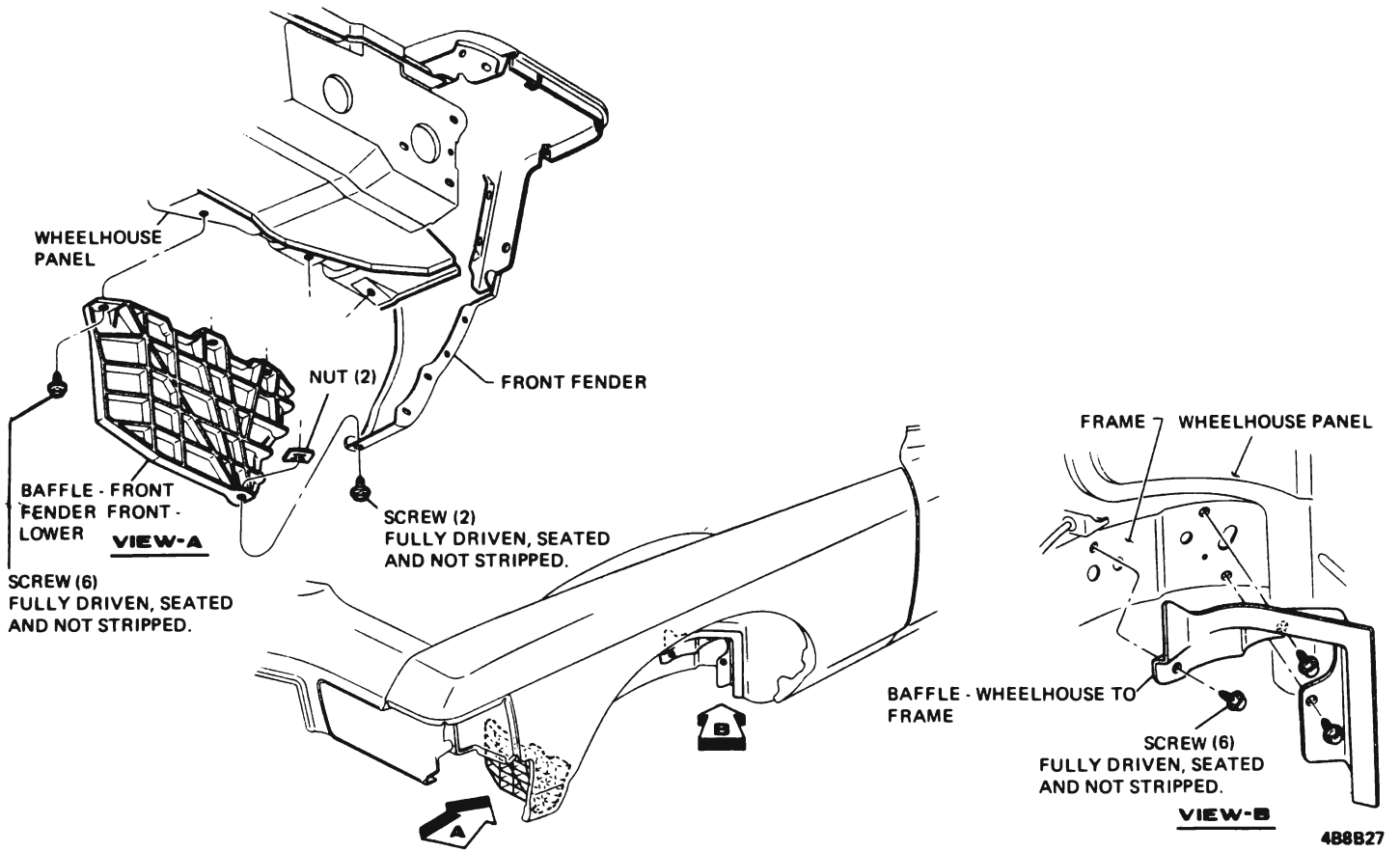

Figure 8B-27 E Series Baffle

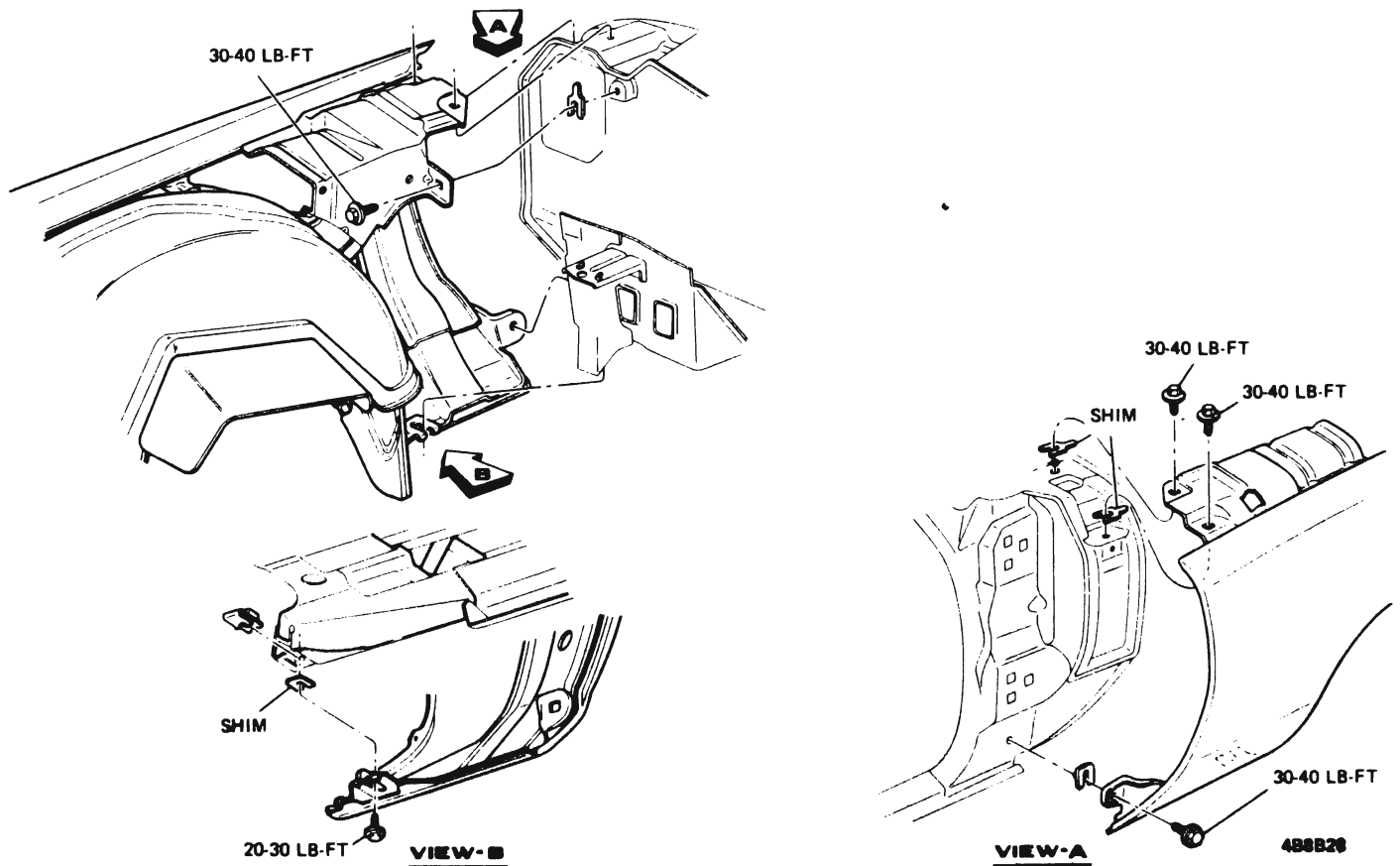

Figure 8B-28 E Series Fender to Body Installation