

350 AND 455 CU.IN. V-8 ENGINES

CONTENTS

Subject	Page No.
DESCRIPTION AND OPERATION:	
Engine Construction	6A-35
Lubrication System and Oil Pump	6A-37
DIAGNOSIS:	
Excessive Oil Consumption	6A-39
Noisy Valves and Lifters	6A-40
MAINTENANCE AND ADJUSTMENTS:	
(Not Applicable)	
MAJOR REPAIR:	
350 and 455 Cu.In. Engine Removal and Installation	6A-41
Exhaust and Intake Manifold, Cylinder Head, Valve Train and Lifters and Oil Pan	6A-42
Connecting Rod Bearings	6A-52
Crankshaft Bearings and Seals	6A-53
Pistons, Rings and Connecting Rods	6A-57
Camshaft and Timing Chain	6A-62
Removal and Inspection of Oil Pump Cover and Gears	6A-67
Engine Mounting, Flywheel and Engine Balancing	6A-67
SPECIFICATIONS:	
Bolt Torque Specifications	6A-69
General Specifications	6A-70
Engine Dimension and Fits	6A-72

DESCRIPTION AND OPERATION

ENGINE CONSTRUCTION

Engine Mounting

For details of engine and transmission mounts refer to Figures 6A-106, 6A-107, 6A-108 and 6A-109.

Engine Construction

The 350, 455 cu. in. engines, with the exception of cylinder bore size and stroke are very similar. Because of the similarity between the two engines, the service procedures, unless otherwise specified will be combined.

The left bank of cylinders (as viewed from rear) is set slightly forward of the right bank so that connecting

rods of opposite sides can be connected to the same crankpin. Starting at the front of the engine, cylinders in the *left* bank are numbered 1-3-5-7 and cylinders in the *right* bank are numbered 2-4-6-8.

The *crankshaft*, nodular cast iron, is supported in the crankcase by five bearings which are identical except number three, which takes end thrust and the rear main which has a different width and material. See Figure 6A-50.

The *crankshaft* is counterbalanced by weights cast integral with the crankshaft. Additional counterbalancing is obtained from the flywheel and harmonic balancer.

The tin plated *aluminum alloy pistons* have full skirts and are cam ground. Two transverse slots in the oil ring grooves extend through the piston wall and permits drain back of oil collected by the oil ring.

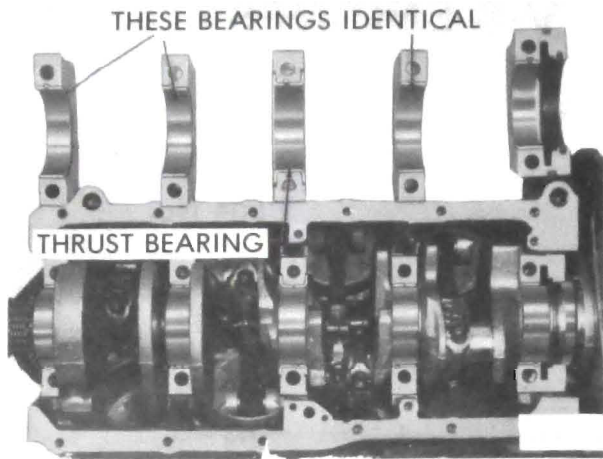

Figure 6A-50 - Engine Crankshaft and Bearings

The *camshaft* is supported in the crankcase by five steel-backed babbitt-lined bearings. It is driven from the crankshaft by sprockets and chain.

The *cylinder heads* are cast iron and incorporate integral valve stem guides and rocker arm shaft pedestals. The 455 STAGE I Engines incorporate exhaust valve seat inserts which are pressed in at assembly. Right and left cylinder heads are identical and interchangeable, although in service, it is good practice to reinstall the cylinder heads on the side from which they are removed.

The *intake manifold* on the V-8 engine utilizes a low restriction, dual intake manifold. It is bolted to the inner edges of both cylinder heads so that it connects with all inlet ports. Since the intake manifold is cast iron, as is the carburetor throttle body, the manifold incorporates a special exhaust heat passage to warm the throttle body. Fuel-air mixture distribution to each intake port is shown in Figure 6A- 51.

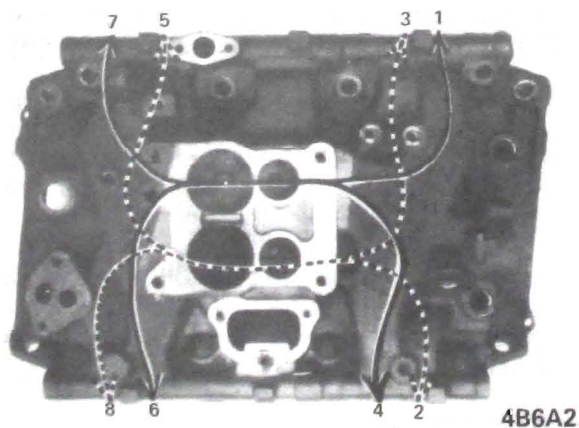

Figure 6A-51 - Intake Manifold Distribution (455 Shown)

All 1974 engines have especially-designed intake manifolds for use with Air Injection Reactor and Exhaust Gas Recirculation Systems.

The E.G.R. System, used on all engines has a cast passage from the exhaust heat passage to the E.G.R. valve and from the valve to hole(s) in the floor of the intake manifold under the carburetor.

Each *exhaust and intake valve* has a spring of ample capacity to insure positive seating throughout the operating speed range. Intake valve heads are 1-7/8" (350 cu.in.) and 2" (455 cu.in.) in diameter and exhaust valves are 1-1/2" (350 cu.in.) and 1-5/8" (455 cu.in.) in diameter. In the 455 STAGE I versions, the intake valves are 2-1/8" in diameter; the exhaust valves are 1-3/4" diameter.

The *valve rocker arms* for each bank of cylinders are mounted on a tubular steel shaft supported on the cylinder head by four pedestals. The rocker arms are stamped steel.

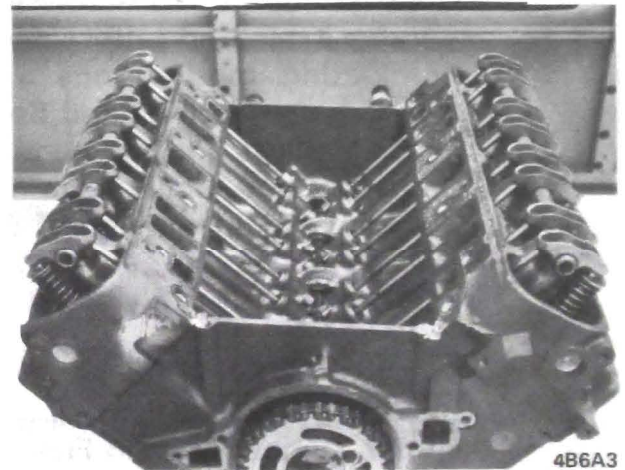

Figure 6A-52 - Engine Valve Mechanism (455 Shown)

Hydraulic valve lifters and tubular push rods are used to operate overhead rocker arms and valves of both banks of cylinders from a single camshaft. This system requires no lash adjustment at time of assembly or in service. Construction and operation of hydraulic valve lifters are described below.

In addition to its normal function of a cam follower, each hydraulic valve lifter also serves as an automatic adjuster which maintains zero lash in the valve train under all operating conditions. By eliminating all lash in the valve train and also providing a cushion of oil to absorb operating shocks, the hydraulic valve lifter promotes quiet valve operation. It also eliminates the need for periodic valve adjustment to compensate for wear of parts.

As shown in Figure 6A-53 all parts of a hydraulic lifter are housed in the lifter body, which is the cam follower. The body and the plunger are ground to

very close limits, then a plunger is selectively fitted to each body to assure free movement with very little clearance. The push rod seat is free to move with the plunger in the body and it provides a spherical seat to support the lower end of the push rod.

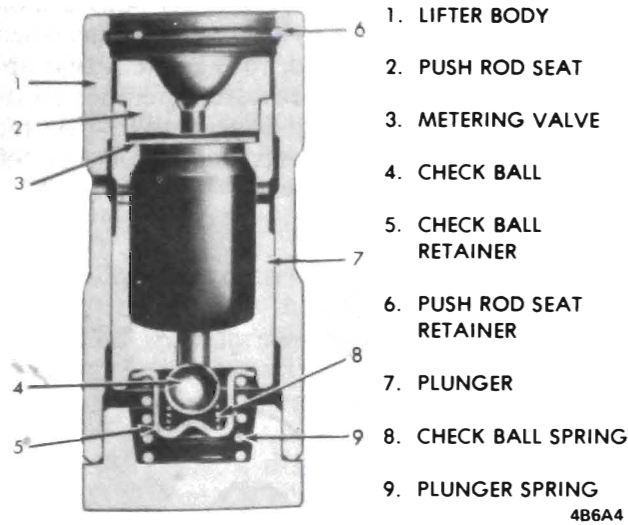

Figure 6A-53 - Hydraulic Valve Lifter

The plunger and seat are pressed toward the upper end of the lifter body by a coil spring which also holds a check ball retainer against the lower end of the plunger. When lifter is out of engine, a spring wire retainer holds all parts in the body. The ball retainer holds a spring loaded check ball in position over the lower end of a feed hole in the plunger.

When the valve lifter is installed in the engine, the push rod holds the seat and plunger downward and clear of the plunger retainer at all times. The plunger spring then presses the lifter body down against the camshaft and presses the plunger and seat up against the push rod with an eight pound load; this is enough to take up all lash clearances between parts in the valve train without affecting positive seating of the valve.

Oil is fed to all lifters through galleries in the crankcase. Oil enters each lifter through grooves and oil holes in the lifter body and plunger, flows down into the chamber below the plunger through the feed hole and around the check ball. The first few cycles of operation after the engine is started forces out all air and completely fills the plunger and lower chamber of each lifter with oil.

At the start of a cycle of valve operation, the lifter body rests on the camshaft base circle. The plunger spring absorbs all lash clearances of the valve train.

As the rotating camshaft starts raising the valve lifter body, oil in the lower chamber and the check ball spring firmly seat the check ball against the plunger to prevent appreciable loss of oil from the lower chamber. The lifting force against the body is then

transmitted through the entrapped oil to the check ball and plunger so that the plunger and push rod seat move upward with the body to operate the linkage which opens the engine valve.

As the camshaft rotates further to close the engine valve, the valve spring forces the valve train and lifter to follow the cam down. When the engine valve seats, the valve train parts and lifter plunger stop but the plunger spring forces the body to follow the cam downward .002" to .003" until it again rests on the camshaft base circle. Oil pressure against the check ball from the lower chamber ceases when the plunger stops and allows passage of oil past the check ball into the lower chamber to replace the slight amount of oil lost by "leak-down".

During the valve opening and closing operation a very slight amount of oil escapes through the clearance between plunger and body and returns to the crankcase. This slight loss of oil (called "leak-down") is beneficial in providing a gradual change of oil in the lifter, since fresh oil enters the lower chamber when pressure is relieved on the check ball at the end of each cycle of operation.

When engine temperature increases and the valve train components expand, the plunger must move to a slightly lower position in the lifter body to assure full closing of the engine valve. When engine temperature decreases and the valve train components contract, the plunger must move to a slightly higher position in the body to prevent lash clearance in the valve train. In either case, the capacity of the lower chamber changes and the volume of oil present is automatically controlled by passage of oil through the plunger feed hole.

LUBRICATION SYSTEM AND OIL PUMP

The engine lubrication system is of the force-feed type in which oil is supplied under full pressure to crankshaft, connecting rods, and camshaft bearings, and is supplied under controlled volume to the valve lifters, rocker arms, and push rods. All other moving parts are lubricated by gravity flow or splash. See Figure 6A-54.

The supply of oil is carried in the lower crankcase (oil pan) which is filled through a filler opening in the left rocker arm cover. A removable oil gauge rod on the left side of the crankcase is provided to check oil level.

The *oil pump* is located in the timing chain cover where it is connected by a drilled passage in the cylinder crankcase to an oil screen housing and pipe assembly. The screen is submerged in the oil supply and has ample area for all operating conditions. If the screen should become clogged for any reason, oil may be drawn into the system through the relief valve in the screen.

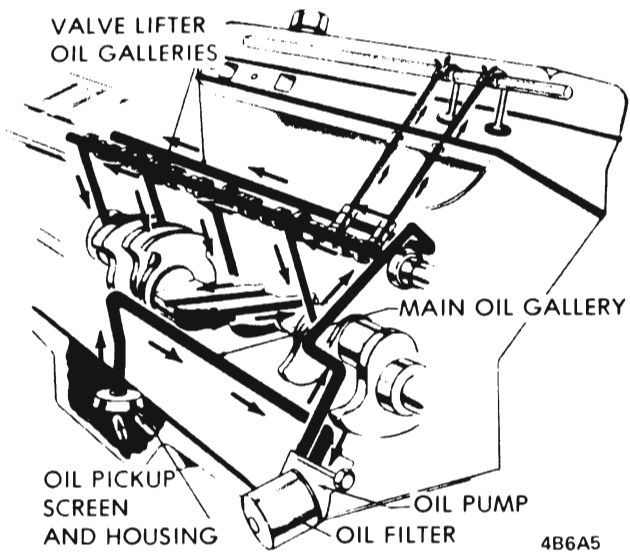

Figure 6A-54 - Schematic Diagram of Engine Oil Flow

Oil is drawn into the pump through the *screen and pipe assembly* and a drilled passage in the crankcase which connects to drilled passages in the timing chain cover. *All* oil is discharged from the pump to

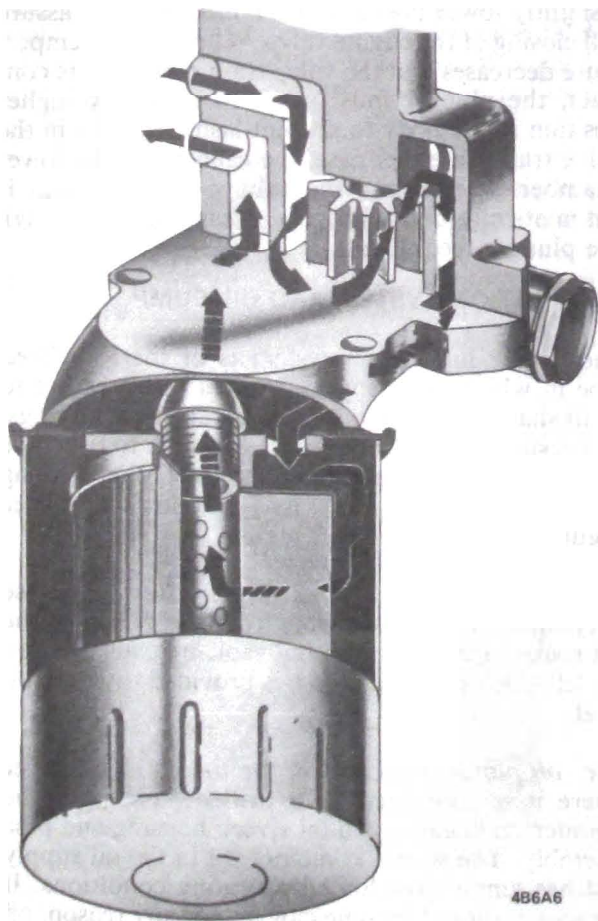

Figure 6A-55 - Oil Pump and Filter Assembly

the oil pump cover assembly. The cover assembly consists of an oil pressure relief valve, an oil filter by-pass valve and a nipple for installation of an oil filter. The spring loaded oil pressure relief valve limits the oil pressure to approximately 40 pounds per square inch (350 engine) or 60 lbs. per square inch (455 engine). The oil filter by-pass valve opens when the filter has become clogged, to the extent that approximately 10-15 pounds pressure difference exists between the filter inlet and discharge, to by-pass the oil filter and channel unfiltered oil directly to the main oil galleries of the engine.

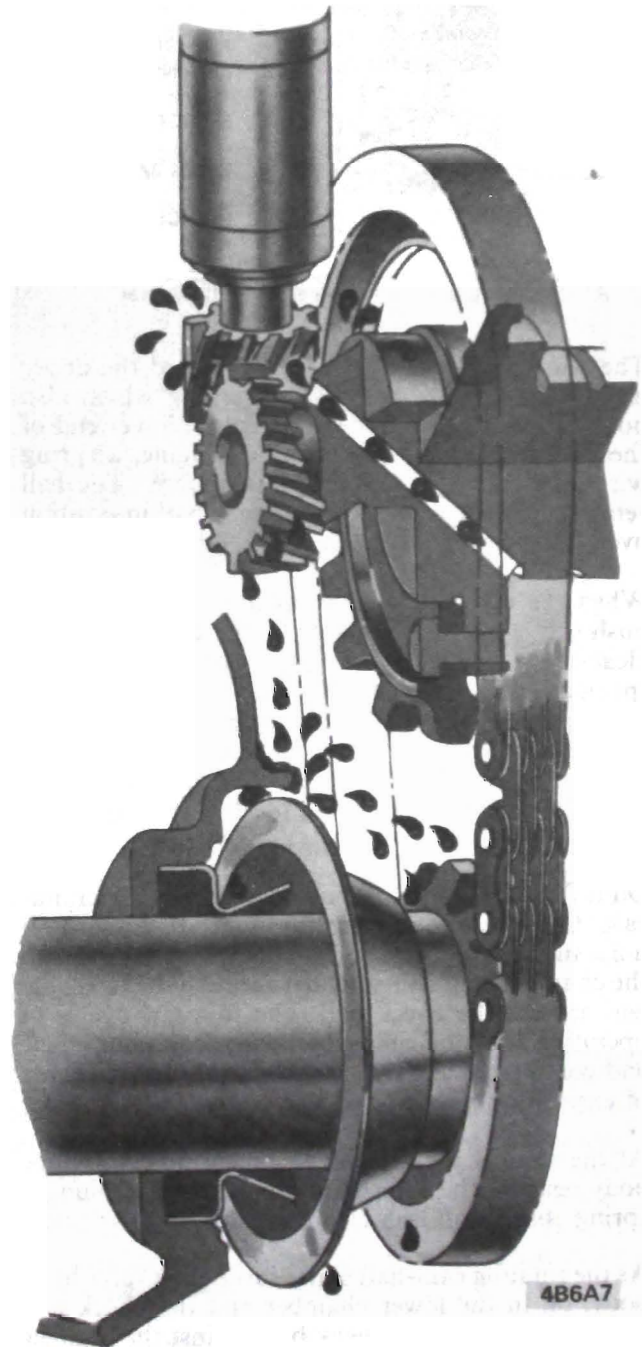

Figure 6A-56 - Front End Lubrication (455 Engine)

An *AC full flow oil filter* is externally mounted to the oil filter cover nipple on the lower right front side of the engine. Normally, all engine oil passes through the filter element, however, if the element becomes restricted, a spring loaded by-pass valve opens as mentioned above.

The *main oil galleries* run the full length of the crankcase and cut into the valve lifter guide holes to supply oil at full pressure to the lifters. Holes drilled from the crankshaft bearings to the main gallery intersect the cam bearing bores to supply oil to the cam bearings.

Holes drilled in the crankshaft carry oil from the crankshaft bearings to the connecting rod bearings. Pistons and cylinder walls are lubricated by oil thrown off the crankshaft and connecting rod splash. Piston pins are lubricated by splash.

In the *350 engine*, a drilled hole in the camshaft connects the front camshaft bearing journal to the keyslot in the front of the camshaft. Oil flows from the journal into the keyslot over the woodruff key in the space between the key and the camshaft sprocket and fuel pump eccentric.

In the *455 engine*, a drilled hole in the camshaft connects the front camshaft bearing journal to the front of the camshaft. Oil flows from the journal through a passage to an outlet between the camshaft sprocket and distributor gear.

The oil stream strikes the distributor gear and provides ample lubrication of the timing chain and sprockets by splash.

Each rocker arm and valve is supplied with oil through the tubular push rod. This oil comes from the inside of the lifter, passing around the metering valve and through a hole in the lifter push rod seat. Oil from the push rod passes through a hole in the rocker arm push rod seat, and emerges on top of the push rod seat boss. See Figure 6A-57.

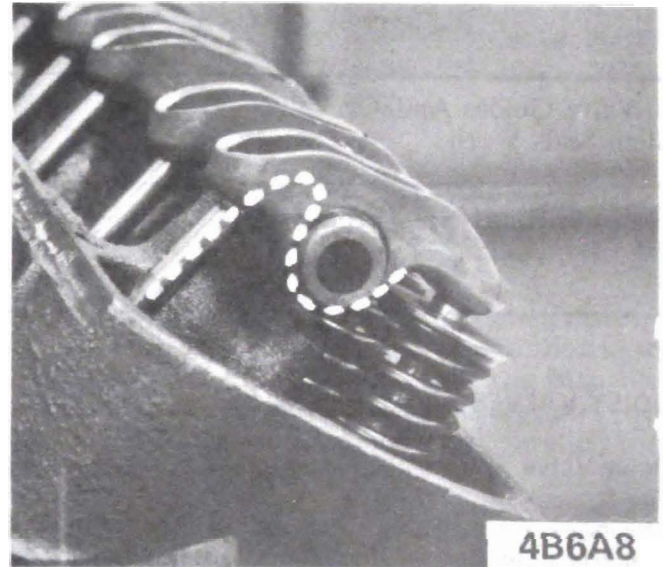

Figure 6A-57 - Overhead Lubrication

DIAGNOSIS

EXCESSIVE OIL CONSUMPTION

Possible Cause	Correction
1. External Oil Leaks at: Rocker Arm Covers Timing Chain Cover Oil Pan and Gasket Between Oil Pan and Flywheel Housing Intake Manifold Gasket	1. Tighten attaching bolts. If leaks persist, remove cover (or pan), check sealing surfaces for burrs, scoring or distorted cover flanges, replace gasket and seal attaching bolts with silastic sealer, or equivalent. Make sure oil level is not overfull.
2. Improper Reading of Dip Stick	1. Car may not be level when taking reading. Insufficient oil "drain-back" time allowed after stopping engine (three minutes must be allowed). Dip stick may not be completely pushed down against stop. Dip stick may be bent.
3. Oil Viscosity Too Light	1. Use recommended SAE viscosity for prevailing temperatures.

Possible Cause	Correction
4. Continuous High Speed Operation	1. At speeds above 60 MPH, increased oil consumption can be expected with any engine. Inform customer of this fact.
5. High Speed Driving Following Normal Slow-Speed City Driving	1. When principal use of automobile is city driving, crankcase dilution from condensation occurs. High-speed and temperatures will remove water, resulting in what appears to rapid lowering of oil level. Inform customer of this fact.
6. Valve Guides And/Or Valve Stem Seals Worn	1. Ream out guides and install service valves with oversize stems and new valve stem seals.
7. Piston Rings Not "Broken In"	1. Allow engine to accumulate at least 4,000 miles before attempting any engine disassembly to correct for oil consumption.

NOISY VALVES AND LIFTERS

Noisy Valve Train

The noise level of the valve mechanism cannot be properly judged when the engine is below operating temperature when the hood is raised, or when the valve rocker arm covers are removed.

Before attempting to judge valve noise level, the engine must be thoroughly warmed up (at least 20 minutes of operation at 1200 to 1500 RPM) to stabilize oil and coolant temperatures and bring all engine parts to a normal state of expansion. When the engine is warmed up, listen for engine noise while sitting in the drivers seat with the hood closed. Run the engine at idle and at various higher speeds. It is advisable to observe the noise level in several engines that have been properly broken in, in order to develop good judgment for checking the noise level in any given engine.

If the preceding check indicates the valve mechanism is abnormally noisy, remove the rocker arm covers so that the various conditions that cause noise may be checked. A piece of heater hose of convenient length may be used to pick out the particular valves or valve train components that are causing abnormal noise. With the engine running at a speed where the noise is pronounced, hold one end of hose to an ear and hold other end about 1/2" from point of contact between rocker arm and valve stem. Mark or record the noisy valves for investigation of following causes.

(1) *Excessive Oil In Crankcase.* Crankcase oil level that is high enough to allow the crankshaft to churn the oil will cause air bubbles in the lubricating system. Air bubbles entering the hydraulic lifters will

cause erratic operation resulting in excessive lash in the valve train. Locate and correct cause of high oil level, then run engine long enough to expel air from system.

(2) *Sticking, Warped or Eccentric Valves, Worn Guides.* Sticking valves will cause irregular engine operation or missing on a low speed pull and will usually cause intermittent noise.

Pour penetrating oil over the valve spring cap and allow it to drain down the valve stem. Apply pressure to the one side of the valve spring and then the other, and then rotate the valve spring about 1/2 turn. If these operations affect the valve noise, it may be assumed that valves should be reconditioned.

(3) *Worn or scored parts in the valve train.* Inspect rocker arms, rocker arm shaft and push rod ends for scoring. Check for bent push rods. Check valve lifters and camshaft surfaces for scoring. Replace faulty parts.

(4) *Valves and seats cut down excessively.* Noisy and improper valve action will result if a valve and its seat have been refinished enough to raise the end of the valve stem approximately .050" above normal position. In this case it will be necessary to grind off the end of the valve stem or replace parts. The normal height of the valve stem above the valve spring seat is 1.933 inches, for 350 cu.in. engines and 2.082 inches for 455 cu.in. engines.

(5) *Faulty Hydraulic Valve Lifters.* If the preceding suggestions do not reveal the cause of noisy valve action, check operation of valve lifters as described in the following paragraph.

Noisy Valve Lifters

When checking hydraulic valve lifters, remember that grit, sludge, varnish or other foreign matter will seriously affect operation of these lifters. If any foreign substance is found in the lifters or engine where it may be circulated by the lubrication system, a thorough cleaning job must be done to avoid a repetition of lifter trouble.

To help prevent lifter trouble, the engine oil and oil filter must be changed as recommended in Group 0. The engine oil must be heavy-duty type (SE marked on container) and must also conform to General Motors Specification 6041-M to avoid detrimental formation of sludge and varnish. A car owner should be specifically advised of these requirements when the car is delivered. Faulty valve lifter operation usually appears under one of the following conditions:

(1) *Rapping noise only when engine is started.* When engine is stopped, any lifter on a camshaft lobe is under pressure of the valve spring; therefore, leak down or escape of oil from the lower chamber can occur. When the engine is started a few seconds may be required to fill the lifter, particularly in cold weather. If noise occurs only occasionally, it may be considered normal requiring no correction. If noise occurs daily, however, check for (a) oil too heavy for prevailing temperatures (b) excessive varnish in lifter.

(2) *Intermittent Rapping Noise.* An intermittent rapping noise that appears and disappears every few seconds indicates leakage at check ball seat due to foreign particles, varnish, or defective surface of check ball or seat. Recondition, clean, and/or replace lifters as necessary.

(3) *Noise at idle and low speed.* If one or more valve lifters are noisy at idle and up to approximately 25 MPH but quiet at higher speeds, it indicates excessive leakdown rate or faulty check ball seat on plunger. With engine idling, lifters with excessive leakdown rate may be spotted by pressing down on each rocker arm above the push rod with equal pressure. Recondition or replace noisy lifters.

(4) *Generally noisy at all speeds.* Check for high oil level in crankcase. With engine idling, strike each rocker arm above push rod several sharp blows with a mallet; if noise disappears, it indicates that foreign material was keeping check ball from seating. Stop engine and place lifters on camshaft base circle. If there is lash in any valve train, it indicates a stuck lifter plunger, worn lifter body lower end, or worn camshaft lobe.

(5) *Loud noise at normal operating temperature only.* If a lifter develops a loud noise when engine is at normal operating temperature, but is quiet when engine is below normal temperature, it indicates an

excessively fast leakdown rate or scored lifter plunger. Recondition or replace lifter.

MAJOR REPAIR

350 AND 455 CU.IN. ENGINE REMOVAL AND INSTALLATION

Removal

1. Remove hood; for easier installation, scribe marks should be made at hood hinge and the hinge bracket.
2. Disconnect battery.
3. Drain coolant into a suitable container.
4. Remove air cleaner.
5. On cars equipped with air conditioning, disconnect compressor ground wire from the mounting bracket. Remove the electrical connector from the compressor clutch, remove the compressor to mounting bracket attaching bolts, and position the compressor out of the way.
6. Remove fan blade, pulleys, and belts.
7. Disconnect radiator and heater hoses from engine and fasten them out of the way.
8. Remove fan shroud assembly.
9. Remove power steering pump to mounting bracket bolts and position pump assembly out of the way.
10. Remove fuel pump hoses and plug hoses.
11. Disconnect battery ground cable from engine.
12. Disconnect the vacuum supply hose from carburetor to the vacuum manifold. On cars so equipped, the vacuum modulator, load leveler, and power brake vacuum hoses should all be disconnected at the engine.
13. Disconnect throttle control cable at carburetor.
14. Disconnect oil and coolant sending unit switch connections at the engine.
15. Disconnect engine to body ground strap at engine.
16. Raise car, disconnect starter cables, and disconnect the cable shield from the engine.
17. Disconnect exhaust pipes from exhaust manifolds and support the exhaust system.

18. Remove lower flywheel and converter cover.
19. Remove flywheel to converter attaching bolts. Scribe chalk mark on the flywheel and converter for reassembly alignment (this is not necessary on manual transmissions).
20. Remove transmission to engine attaching bolts.
21. Remove motor mount fasteners.
22. Lower the car and support the transmission.
23. Attach a lifting device to the engine and raise the engine enough so mounting through-bolts can be removed. Make certain wiring harness, vacuum hoses, and other parts are free and clear before lifting engine out of car.
24. Raise engine far enough to clear engine mounts, raise transmission support accordingly and alternately until engine can be disengaged from the transmission and removed.

Installation

1. Slowly lower engine into car until engine and transmission are engaged and scribe marks are aligned.
 2. It may be necessary to alternately raise and lower transmission to fit motor mount through-bolts into position. Install through-bolt nuts and torque to 63 lb.ft.
 3. Raise car and install transmission to engine attaching bolts. Torque flywheel housing to engine bolts to 35 lb.ft. Install flywheel cover and torque bolts to 4 lb.ft.
 4. Connect crossover pipe to exhaust manifold and torque bolts to 10-18 lb.ft.
 5. Connect the starter cables to the starter and cable shield to the engine block.
 6. Lower the car and reconnect the body ground strap to the engine, the coolant and oil switch sending unit connectors, the throttle control cable, all vacuum and water hoses, and the emission control line from the canister to the air cleaner.
 7. Connect the battery ground cable to the engine.
 8. Connect the fuel lines to the fuel pump.
 9. Reposition the power steering pump into the pump brackets and secure.
 10. Install fan shroud.
 11. Install pulley, fan, and belts. Belt tension is as follows:
 - a. Delcotron - 80 Lbs.
 - b. Power Steering - 90 Lbs.
 - c. Air Conditioning - 100 Lbs.
 - d. A.I.R. Pump - 65-80 lbs.
 12. Reinstall air conditioning compressor to bracket.
 13. Reinstall air cleaner.
 14. Reinstall coolant and check to make certain proper level is attained.
- After complete engine assembly, start engine and recheck for proper fill.
15. Reinstall hood, noting proper alignment of scribe marks.
 16. Connect battery.

EXHAUST AND INTAKE MANIFOLD, CYLINDER HEAD, VALVE TRAIN AND LIFTERS AND ENGINE OIL PAN REMOVAL AND INSTALLATION

Intake Manifold Removal

1. Disconnect battery.
2. Drain coolant from radiator.
3. Remove air cleaner.
 - a. Disconnect breather tube at air cleaner.
 - b. Disconnect heated air pipe at top end of pipe.
 - c. Disconnect air cleaner sensor hose at tee.
4. Remove air conditioning mounting bracket bolt (if equipped). Loosen bracket to compressor bolt and slide bracket outboard.
5. Disconnect water temperature indicator wire from switch.
6. Disconnect throttle linkage at carburetor.
7. Disconnect fuel line at carburetor inlet.
8. Remove manifold attaching bolts and manifold.

Intake Manifold Installation

1. Place new intake manifold gasket and rubber manifold seals in position at front and rear rails of

cylinder block. Be sure pointed end of seal fits snugly against block and head. Before installing intake manifold seals apply Silastic Sealer or equivalent to ends of seals. See Figure 6A-58.



Figure 6A-58 - Intake Manifold Seal Installation

2. Install one piece manifold gasket and carefully set intake manifold on the engine block dowel pin.

3. Install manifold to cylinder head bolts.

New intake manifold gasket and seals must be used whenever a manifold is removed.

When installing manifold, start with the No. 1 and No. 2 bolts. See Figure 6A-59. Gradually tighten both bolts until snug. Then continue with the rest of the bolts in the sequence shown in Figure 6A-59. Torque bolts to 45 lb. ft.

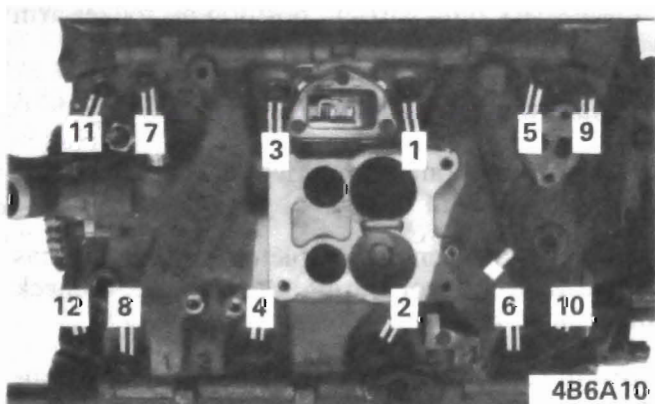

Figure 6A-59 - Intake Manifold Bolt Tightening Sequence

6. Close drain plug and fill radiator to proper level.

Cylinder Head Removal

1. Remove intake manifold.

2. When removing RIGHT cylinder head:

X-A-B-C-E Series

(a) Loosen and remove belt (s).

(b) Remove wires from Delcotron.

(c) If equipped with air conditioning compressor, remove compressor from mounting bracket and position it out of the way with hoses connected, then remove Delcotron with mounting bracket.

(d) Disconnect metal temperature indicator wire (if equipped).

3. When removing LEFT cylinder head;

A-B-C-E Series

(a) Remove oil gauge rod.

(b) Remove power steering gear pump with mounting bracket if present, and move it out of the way with hoses attached.

4. Disconnect wires from spark plugs, and remove the spark plug wire clips from the rocker arm cover studs.

5. Remove exhaust manifold bolts from head being removed.

7. With air hose and cloths, clean dirt off cylinder head and adjacent area to avoid getting dirt into engine. *It is extremely important to avoid getting dirt into the hydraulic valve lifters.*

8. Remove rocker arm cover and rocker arm and shaft assembly from cylinder head. Lift out push rods.

If lifters are to be serviced, remove them at this time. Otherwise, protect lifters and camshaft from dirt by covering area with a clean cloth. Whenever lifters or push rods are removed, place in a wooden block with numbered holes or similar device to keep them identified as to position in engine.

9. Loosen all cylinder head bolts, then remove bolts and lift off the cylinder head.

10. With cylinder head on bench, remove all spark

4. Connect parts removed in Steps 3 thru 9.

5. Connect battery.

plugs for cleaning and to avoid damage during work on the head.

Left Cylinder Head Removal

X-Series

1. Remove intake manifold.
2. Remove oil gauge rod.
3. Remove A.I.R. pump.
4. Remove power steering pump with hoses connected and swing out of way.
5. Remove power steering pump bracket.
6. Disconnect spark plug wires and swing out of the way.
7. Remove rocker arm cover, rocker arm and shaft assembly from cylinder head. Lift out push rods.

If lifters are to be serviced, remove them at this time. Otherwise, protect lifters and camshaft from dirt by covering area with a clean cloth. Whenever lifters or push rods are removed, place in a wooden block with numbered holes or similar device to keep them identified as to position in engine.

8. Disconnect power brake unit hose at rear of cylinder head.

9. Raise vehicle and place on jack stands, disconnect exhaust crossover pipes and support, (if dual exhaust disconnect left exhaust pipe).

10. Remove left front engine mount thru bolt and "loosen" right front engine mount thru bolt.

11. Raise the engine (if chain fall is used hood will have to be removed).

12. Remove cylinder head bolts and remove cylinder head.

NOTE: *If exhaust manifold does not clear steering gear, engine may have to be raised further.*

Cylinder Head Installation

All Series

1. Thoroughly clean off engine block gasket surface and be certain no foreign material has fallen in the cylinder bores, bolt holes, or in the valve lifter area. It is good practice to clean out bolt holes with an air hose.

2. Install new head gasket on cylinder block. Dowels in the block will hold the gasket in place. Always handle gaskets carefully to avoid kinking or damage to the surface of the gasket.

3. Clean gasket surface of cylinder head and carefully set in place on the engine block dowel pins.

4. Clean and lubricate the head bolts with engine oil.

Use an accurate torque wrench when installing head bolts. Uneven tightening of the cylinder head bolts can distort the cylinder bores, causing compression loss and excessive oil consumption.

5. Install head bolts. Tighten the bolts a little at a time about three times around in the sequence shown in Figure 6A-60. Give bolts a final torque in the same sequence. Torque to 80 lb.ft. (350 Cu In.) and 100 lb. ft. (455 Cu. In.).

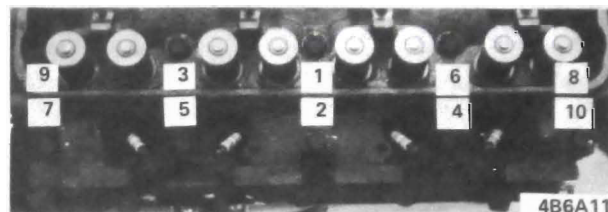

Figure 6A-60 - Cylinder Head Bolt Tighten Sequence (455 Shown)

6. Assemble exhaust manifolds to heads. Torque bolts to 28 lb. ft.

7. Wipe rocker arm shaft and bosses on cylinder head with a clean cloth.

8. Install push rods.

9. Tilt the rocker arm toward the push rod and locate the top of each push rod in its rocker arm seat.

10. Draw down the rocker arm and shaft assembly by tightening the shaft bolts a little at a time. Use a reliable torque wrench to torque the shaft bolts to 25 lb. ft. Do not overtighten.

11. Place spark plug wires in position on rocker arm cover studs and connect spark plug wires.

12. Install intake manifold.

13. Replace components removed in cylinder head removal and tighten belt(s).

14. After installation is completed and engine has been warmed up to operating temperature, recheck cylinder head bolt torque.

15. Install rocker arm cover and new gasket torque bolts to 4 lb.ft.

Reconditioning Valves and Guides

1. Remove cylinder head. Place on a clean surface.

2. Using suitable spring compressor, such as J-8062, compress valve spring and remove valve spring cap

key. Release tool and remove spring and cap. See Figure 6A- 61.

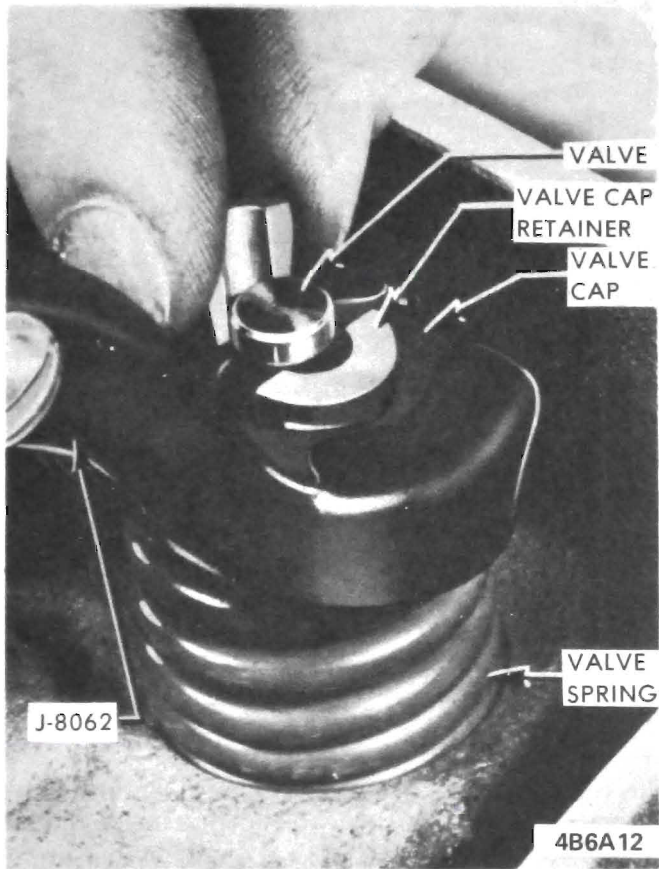

Figure 6A-61 - Removing Valve Cap Retainers.

3. Remove valve seals from intake valve guides. Seals must be discarded. Remove valves. Place valves in numerical order so that they can be reinstalled in original location.

4. Remove all carbon from combustion chambers, piston heads, and valves. When using scrapers or wire brushes for removing carbon, avoid scratching valve seats and valve faces. A soft wire brush (such as J-8358) is suitable for this purpose.

5. Clean carbon and gum deposits from valve guide bores. Use Reamer J-8003.

6. Inspect valve faces and seats for pits, burned spots or other evidences of poor seating. If a valve head must be ground until the outer edge is sharp in order to true up the face, discard the valve because the sharp edge will run too hot. 45 degrees is the correct angle for valve faces.

7. If valve stem has too much clearance in its guide, the guide should be reamed to .006" oversize using J- 22612 and then to .010" oversize using Reamer J-9345-1. See Figure 6A-62.

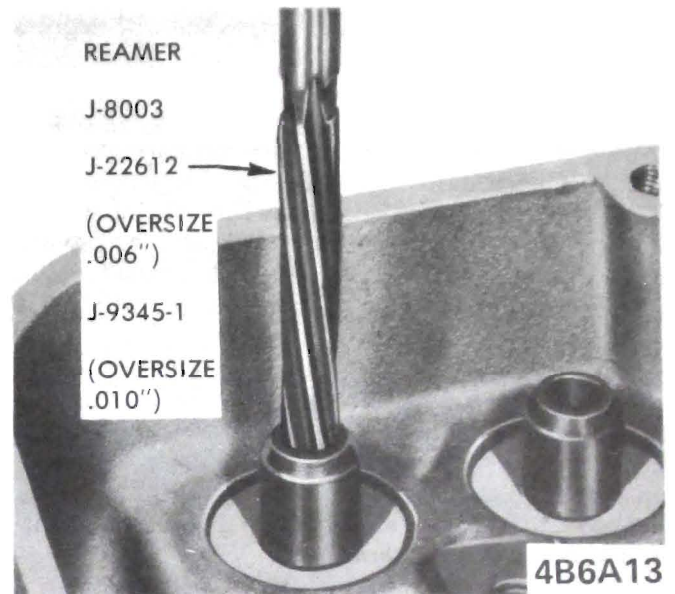

Figure 6A-62 - Reaming Valve Guide

.006" oversize valves are occasionally used in production. If clearance in the guide exceeds .006" the guide should be reamed to .010" oversize using J-9345-1. Oversize valves are identified by the oversize marking stamped on the valve head. See Figure 6A-63.

The Parts Department stocks .010" oversize valves for replacement purposes. See Figure 6A-63.



Figure 6A-63 - Oversize Valve Identification

8. True up valve seats to 45 degrees. Cutting a valve seat results in lowering the valve spring pressure and increases the width of the seat. The nominal width of the valve seat is 1/16". If a valve seat is over 5/64" wide after truing up it should be narrowed to speci-

fied width by the use of 20 degrees and 70 degrees stones.

Improper hydraulic valve lifter operation may result if valve and seat have been refinished enough to allow the end of valve stem to raise approximately .050" above normal position. In this case it will be necessary to grind off end of valve stem or replace parts. *The normal height of the valve stem above the valve spring seat surface of the head is 1.933" (350 Cu. In.) and 2.082" (455 Cu. In.).*

9. Lightly lap the valves into seats with the fine grinding compound. The refacing and reseating operations should leave the refinished surfaces smooth and true so that a minimum of lapping is required. Excessive lapping will groove the valve face preventing a good seat when hot.

New valves should not be lapped under any condition as the .0002" - .0015" aluminum alloy surface on the intakes or the .0004" to .0015" nickel-plated surface on the exhausts will be removed.

10. Test valves for concentricity with seats and for tight seating. The usual test is to coat the valve face lightly with Prussian blue and turn the valve against seat. If the valve face is concentric with the valve stem a mark will be made all around the face, while if the face is not concentric with the stem, a mark will be made on only one side of the *face*. Next, coat the valve seat lightly with Prussian blue. Rotate the valve against the seat to determine if the valve seat is concentric with the valve guide, and if the valve is seating all the way around. Both of these tests are necessary to prove that a proper seat is being obtained.

11. Remove any burrs from valve stem with a fine stone and polish with crocus cloth.

12. Lubricate valve stems and guides with engine oil and reinstall valves.

13. Install intake valve seals.

Do not install exhaust valve guide seals.

a. Start valve seal carefully over valve stem. Push seal down until it touches top of guide.

b. Use installation tool J-22509 to push seal over valve guide until upper inside surface of seal touches top of guide.

COMPRESS SPRINGS ONLY ENOUGH TO INSTALL KEEPERS. EXCESS COMPRESSION CAN CAUSE SPRING RETAINER TO DAMAGE VALVE SEAL.

14. Install valve springs on the 350 cu. in. with close-wound coil toward the cylinder head. All valve

springs for 455 cu. in. engines, may be installed with either end up. See Figure 6A-64.

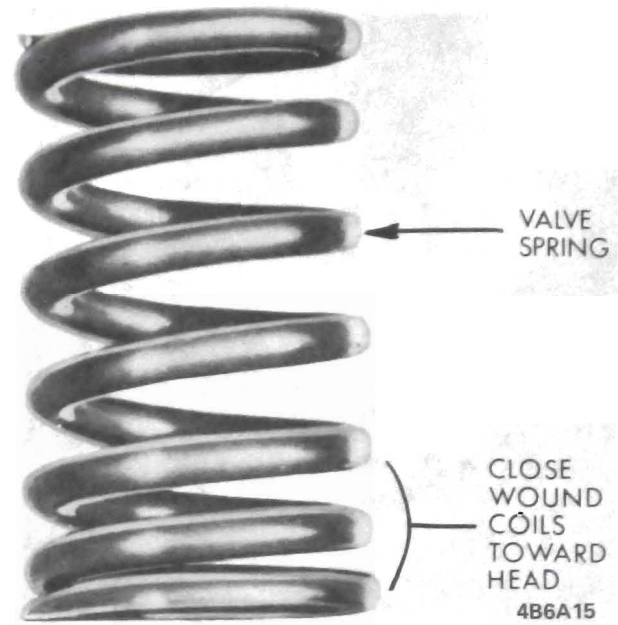

Figure 6A-64 - Valve Spring (350 cu.in.)

The top inside diameter of 350 cu.in. intake valve springs is .860" - .846" and the bottom inside diameter is .945" - .931". The large diameter must be toward the cylinder head.

15. Reinstall valve spring, cap and cap retainer, using same equipment used for removal.

16. Install cylinder head.

Rocker Arm Assembly Removal

1. Remove rocker arm cover and remove four rocker arm and shaft assembly to cylinder head bolts. Remove shaft assembly.

2. Place assembly on a clean surface.

3. Remove nylon arm retainers by prying them out using a pair of channel locks. See Figure 6A-65.

4. Remove rocker arms and clean in suitable solution. Inspect for wear. Remove retainer pieces from inside shaft.

Rocker Arm Assembly Installation

1. Install rocker arms on shaft lubricating all parts as they are assembled with engine oil. One common rocker arm is used in all locations on all 1974 production V-8 engines, and therefore can be installed in any sequence on the rocker arm shaft.

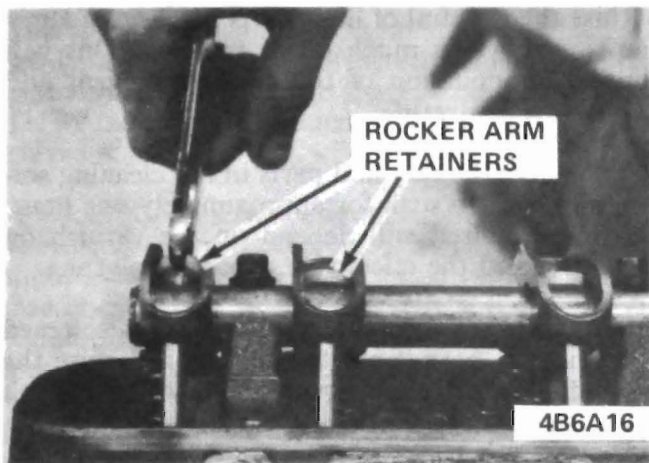

Figure 6A-65 - Removing Nylon Retainer

Should it become necessary to replace one or more rocker arms, it must be noted that service rocker arms are stamped (R) right (L) left. See Figure 6A-66

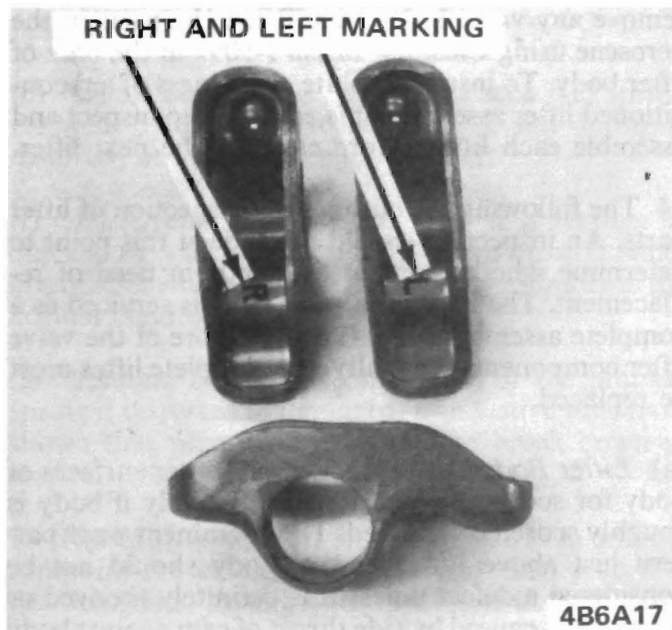

Figure 6A-66 Service Rocker Arms

When installing service rocker arms care must be taken to insure rocker arms are installed on the rocker arm shaft in the correct sequence. See Figure 6A-67.

2. Center each arm on the 1/4" hole in the shaft. Install new nylon rocker arm retainers in the 1/4" holes using a drift of at least 1/2" dia.
3. Install rocker arm assembly.

Valve Lifter Service

1. Refer to procedure outlined under "Cylinder Head Removal" for lifter removal.

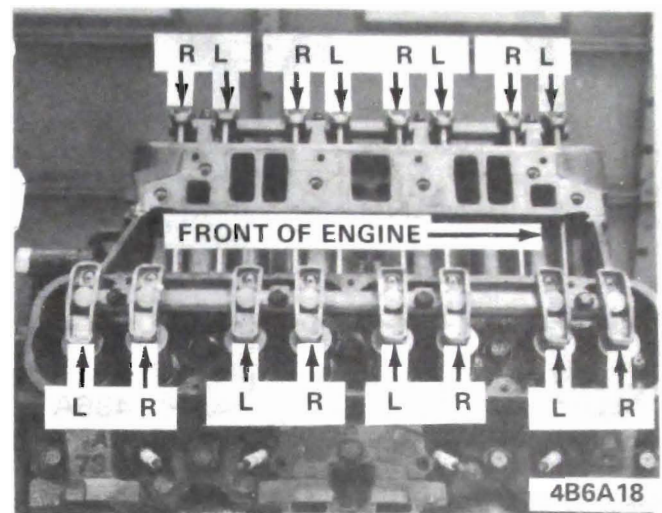

Figure 6A-67 Position of Service Rocker Arms on Shaft

CAUTION: *In production .010" oversize valve lifters are being used to compensate for oversize lifter bores in the cylinder block. The lifter bores will be marked with an "O" and the lifter will be marked with two grooves in the lifter body. When replacing valve lifters check lifter bores for oversize marking so as to be sure oversize lifters are installed in the oversize bores.*

2. Place lifter in a wooden block with numbered holes or similar device to keep them identified as to position in engine.
3. If less than a complete set of lifters are being removed, disassemble one or two and check for dirt or varnish. If this condition exists, it is advisable to remove all lifters for cleaning and inspection. Otherwise, service only those lifters that are not operating properly.
4. Examine the cam contact surface at lower end of lifter body. If this surface is worn, galled, or otherwise damaged, discard the lifter assembly. In this case, examine the mating camshaft lobe for wear or damage.
5. Disassemble each valve lifter by using a push rod to hold down the push rod seat while removing the plunger retainer from the lifter body using Retainer Remover J-5238. See Figure 6A-68. Remove push rod seat, oil metering valve, and plunger from lifter body.
6. If a plunger sticks in lifter body, place lifter in large end of Plunger Remover J-4160-A with plunger inward. While holding lifter with thumb, rap the open end of remover against a block of wood with

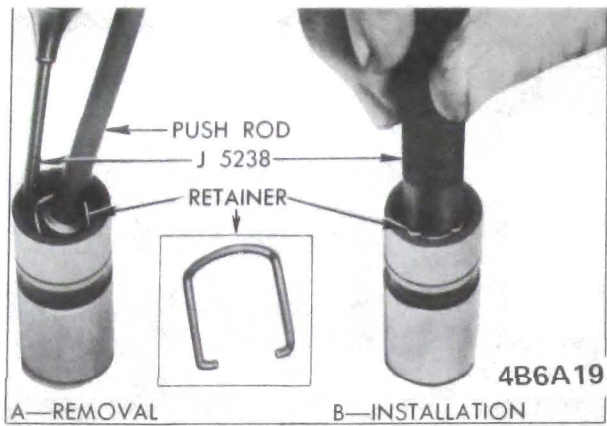

Figure 6A-68 - Removing and Installing Plunger Retainer

just enough force to jar the plunger from body. See Figure 6A-69.

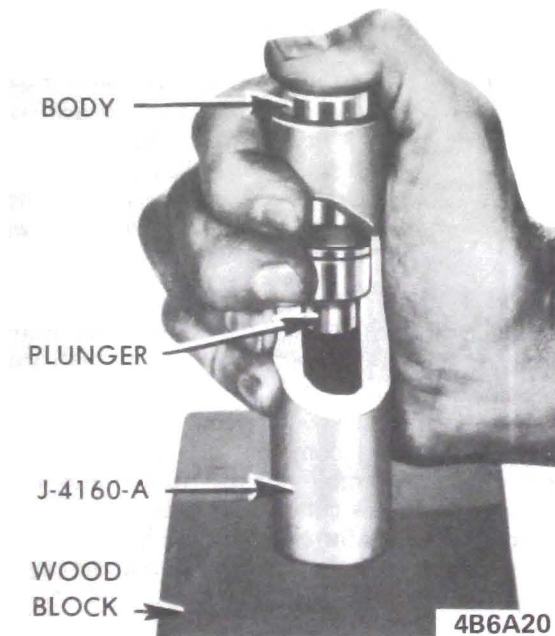

Figure 6A-69 - Removing Stuck Plunger

7. Drain oil out of body into waste can and remove the ball retainer, ball, ball spring, and plunger spring. A strainer placed over waste can will prevent dropping these parts into can.

8. Place all parts of each lifter in a separate compartment of a tray.

The body and plunger are selectively fitted to each other and must not be interchanged with parts of other lifters. Keeping all parts of the lifter together until cleaned and inspected will aid in diagnosing cause of improper operation.

9. Rinse the tray full of lifter parts in a pan of kerosene to remove as much oil as possible. This will reduce contamination of the cleaning solvent and extend its effective life.

10. Submerge the tray and parts in the cleaning solvent and leave to soak for approximately one hour. The time required will depend on the varnish on lifter parts and the effectiveness of the solvent.

11. After the varnish has dissolved or has softened sufficiently to permit removal by wiping, raise the tray and allow tray and parts to drain so that solvent will be saved.

12. Rinse the tray of parts in the pan of kerosene to cut the solvent and avoid injury to hands.

13. Working on one lifter at a time and using CLEAN lint-free cloths, thoroughly wipe off all parts. Clean the plunger and the external and internal surfaces of the body with a hard wiping action to remove any varnish deposits. Rinse the parts in the kerosene using Cleaning Brush J-5099 in the bore of lifter body. To insure absolute cleanliness of a reconditioned lifter assembly, it is advisable to inspect and assemble each lifter before cleaning the next lifter.

14. The following list outlines the inspection of lifter parts. An inspection should be made at this point to determine whether or not a lifter is in need of replacement. The hydraulic valve lifter is serviced as a complete assembly only. If one or more of the valve lifter components are faulty, the complete lifter must be replaced.

(a) *Lifter Body.* Inspect inner and outer surfaces of body for scoring. Replace lifter assembly if body is roughly scored or grooved. The prominent wear pattern just above lower end of body should not be considered a defect unless it is definitely grooved or scored; it is caused by side thrust of cam against body while the lifter is moving vertically in its guide.

Inspect the cam contact surface on lower end of lifter body. Replace the lifter assembly if this surface is worn, galled, or otherwise damaged. All 1974 V-8 engines have valve lifters with a slight spherical shaped base that will allow lifter rotation, which is induced by the tapered lobes on the camshaft producing camshaft thrust rearward, causing lifter rotation.

(b) *Lifter Plunger.* Using a magnifying glass, inspect the check ball seat for defects. Inspect outer surface of plunger for scratches or scores. Small score marks with a rough, satiny finish will cause the plunger to seize when hot but operate normally when cool. Defects in check ball seat or scoring or scratches on outer surface of plunger which may be felt with a fingernail are causes for replacing the lifter assembly.

This rule does not apply to the slight edge which may sometimes be present where the lower end of plunger extends below the ground inner surface of the body. This edge is not detrimental unless it is sharp or burred.

A blackened appearance is not a defective condition. Sometimes the discoloration serves to highlight slight grinder chatter marks and give the outer surface of plunger a ridged or fluted appearance. This condition will not cause improper operation, therefore it may be disregarded.

(c) *Push Rod and Seat.* Replace lifter if the area where the push rod contacts the push rod seat is rough, or otherwise damaged. Replace any push rod having a rough or damaged ball end.

(d) *Check Ball.* Using a magnifying glass, carefully examine the check ball for nicks, imbedded material or other conditions which would prevent proper seating. Such conditions would indicate the cause of intermittently noisy lifter operation.

(e) *Check Ball Spring.* Examine check ball spring for wear or damage. Replace lifter if any spring is distorted or shows evidence of wear.

(f) *Ball Retainer.* Replace lifter if a retainer is cracked or which has a heavily worn area. A small bright spot where the ball contacts the retainer is the normal condition.

(g) *Plunger Spring.* Replace lifter if the plunger spring is distorted or damaged. Exhaustive tests have shown that plunger springs seldom break down in service.

15. Rinse lifter plunger in the kerosene in middle compartment of cleaning tank and then give it a thorough final rinsing in the kerosene in right compartment.

16. Hold plunger in vertical position with feed hole up, then rinse and install the check ball, check ball spring, ball retainer, spring, and body over the plunger. See parts in Figure 6A-70.

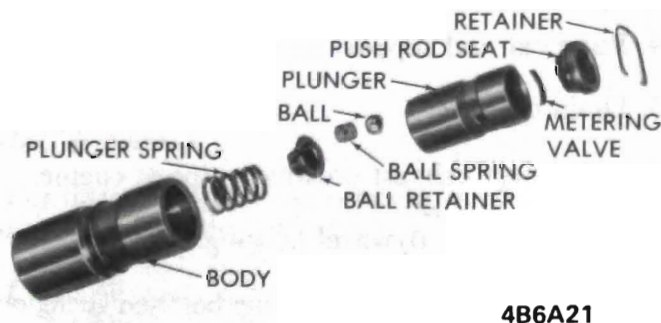

4B6A21

Figure 6A-70 - Hydraulic Valve Lifter Parts

17. Rinse push rod seat, metering valve, and plunger retainer. Place these parts in end of body and push with handle of Remover J-5238 until retainer engages groove in body. See Figure 6A-68, View B.

18. Wrap the lifter in clean paper or otherwise protect it from dirt while reconditioning the other valve lifters, preparatory to testing all lifters for leakdown rate.

19. Check lifter leakdown rate according to paragraph below.

20. Make certain that valve lifter guide holes and adjacent area of cylinder block are clean. Liberally lubricate the camshaft and lifter bores with "Engine" oil and install lifters. Each lifter must slide freely in its guide hole.

21. Reassemble engine as outlined in cylinder head installation.

Checking Valve Lifter Leakdown Rate

After a hydraulic lifter has been cleaned, inspected, and assembled it must be tested before it is installed in an engine. Lifter Test Fixture J-5790 has been designed to test the leakdown rate of a lifter to determine whether it is within limits which assure satisfactory lifter operation.

The following procedure must be carefully followed to obtain an accurate test.

1. Thoroughly clean the cup of test fixture, install cup on fixture, and fill it to within 1/2" of the top with "Hydraulic Lifter Test Fluid."

2. Remove rubber washer (used for larger lifters) and install Gage Sleeve J-5790-27 in the cup; also install Gage Rod Nose J-5790-13 in the arm.

3. Swing the weight arm up out of the way, raise the ram and place the valve lifter (top side up) in Sleeve J-5790-27. The lifter must be completely covered by the fluid during test.

4. Lower the ram to rest in the lifter push rod seat, then lower the weight arm to rest on the roller of ram as shown in Figure 6A-71.

5. Operate the lifter plunger through its full travel to force all air out of the lifter by using a vigorous pumping action on the weight arm. Continue the pumping action until considerable resistance is built up in the lifter and a definite grab point is felt at the top of the stroke, when the indicator pointer is at the bottom of the scale.

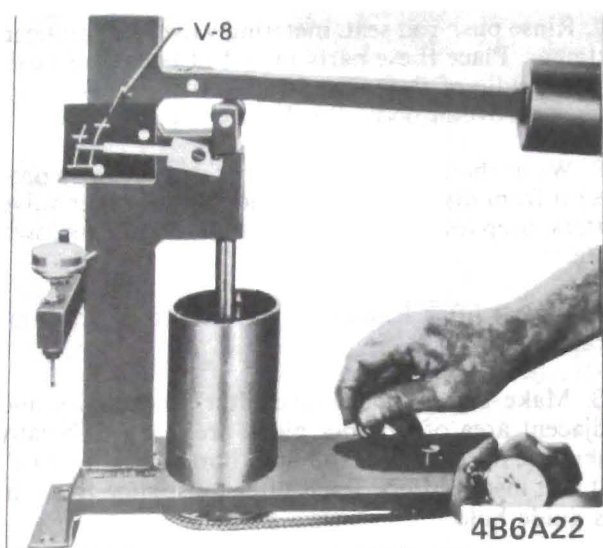

Figure 6A-71 - Checking Lifter Leakdown Rate

Finally, pump vigorously for approximately 10 additional strokes to make sure all air is removed from the lifter.

6. Raise weight arm to allow the lifter plunger to come up to its retainer, then lower the arm to rest on the ram roller. As the pointer starts moving upward start rotating the fluid cup by turning the handle one revolution every two seconds.

7. Use a stop watch to check the time required for pointer to move from the lower to the upper mark on scale where marked "BUICK V-8." The cup must be rotated during this test.

8. The leakdown rate (time between marks) must be between 12 and 60 seconds to assure satisfactory lifter performance. A doubtful lifter should be tested three or four times. Replace any lifter which does not test within the specified limits.

The newer Model J-5790 leakdown tester will have a different scale than the one shown in Figure 6A-71. In this case, time the pointer travel from "Start" to the .125 mark on the scale. The leakdown rate must still be between 12 and 60 seconds.

9. After all lifters have been tested, place the cover over the test fixture to keep dirt out of the cup and fluid. The fluid should be discarded and the cup should be thoroughly cleaned after a few sets of lifters have been tested.

Exhaust Manifold Removal Right and Left

A-B-C-E Series and X-Series Right Side

1. Raise front of car and support on stands.

2. Disconnect exhaust pipe from exhaust manifold on both sides of engine and lower. (If equipped with dual exhaust remove the side to be worked on only.)

3. If manual transmission remove equalizer shaft.

4. Remove exhaust manifold to cylinder head bolts.

5. Remove exhaust manifold from beneath the car.

X-Series Left Side

1. Raise vehicle.

2. Disconnect crossover pipe (if dual exhaust disconnect left exhaust pipe only).

3. Remove left front engine mount thru bolt and "loosen" right front engine mount thru bolt.

4. Raise engine.

5. Remove exhaust manifold bolts and exhaust manifold.

X-Series Installation (Left Side)

1. Install exhaust manifold by reversing removal procedures.

Exhaust Manifold Installation Right and Left

A-B-C-E Series and X Series Right Side

1. Install manifold by reversing above procedures.

2. Torque exhaust manifold bolts to 28 lb. ft.

Oil Pan Removal

A-B-C-E Series

1. Disconnect battery.

2. Remove fan shroud to radiator tie bar screws.

3. Remove air cleaner and disconnect throttle linkage.

4. Raise car and support on stands.

5. Drain oil.

6. Disconnect exhaust crossover pipe at engine.

7. Remove lower flywheel housing.

8. Remove shift linkage attaching bolt and swing out of way.

9. Remove front engine mounting bolts.

10. Raise engine by placing jack under crankshaft pulley mounting.

At this point, on A/C equipped cars, it will be necessary to place a support under the right side of the transmission prior to raising engine. This is necessary to prevent the engine transmission assembly from cocking to the right when being raised.

11. Remove oil pan bolts and remove pan.

It may be necessary to position crankshaft so No. 1 and 2 crankpin and counterweight will not interfere with front of oil pan.

12. Remove rear seal (455 cu.in. engines only).

X-Series

1. Disconnect battery.
2. Remove fan shroud to radiator tie bar screws.
3. Remove air cleaner and disconnect throttle linkage at intake manifold.
4. Raise vehicle and place on jack stands.
5. Drain oil.
6. Remove lower flywheel housing cover.
7. Remove shift linkage attaching bolt and swing out of the way.
8. Disconnect exhaust crossover pipe at engine.
9. Remove front engine mount thru bolts.
10. Disconnect idler arm at frame and swing assembly downward.
11. Raise engine (if chain fall is used hood must be removed).
12. Remove oil pan bolts and remove oil pan.

It may be necessary to position crankshaft so No. 1 and 2 crank pin and counter weight will not interfere with front of oil pan.

Oil Pan Installation

A-B-C-E Series

1. For installation, reverse procedures of oil pan removal observing the following:
2. Clean oil pan. Make sure the gasket surfaces on pan and block are clean.
3. Install rear seal (455 cubic inch engines only).

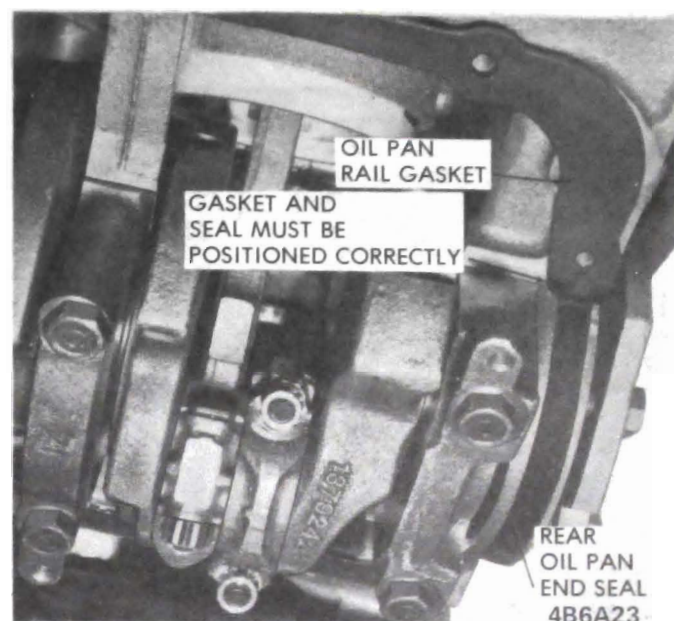

Figure 6A-72 - Oil Pan Gasket and Seal Installation

4. Apply silastic sealer to a few spots on a new pan gasket and install on block. *Make sure seal and gasket are properly fitted.* See Figure 6A-72. (455 cu. in. only).

5. Install oil pan. Torque bolts to 14 lb. ft. Do not overtighten.

X Series

Install oil pan reversing the removal procedure, observing the following.

1. Clean oil pan. Make sure the gasket surfaces on pan and block are clean.
2. Apply silastic sealer to a few spots on a new pan gasket and install gasket to block.

Removal and Inspection of Oil Pump Pipe and Screen Assembly

1. Remove oil pan.
2. Remove oil pump pipe and screen assembly to cylinder block bolts.
3. Clean the screen and housing thoroughly in solvent and blow dry with air stream.

Installation of Oil Pump Pipe and Screen Assembly

Install by reversing removal procedure, paying particular attention to the following points.

1. Make sure oil pump pipe flange gasket surface of block is smooth and free of dirt.

2. Use new gasket and tighten bolts to 8 lb. ft. torque. See Figure 6A-73.

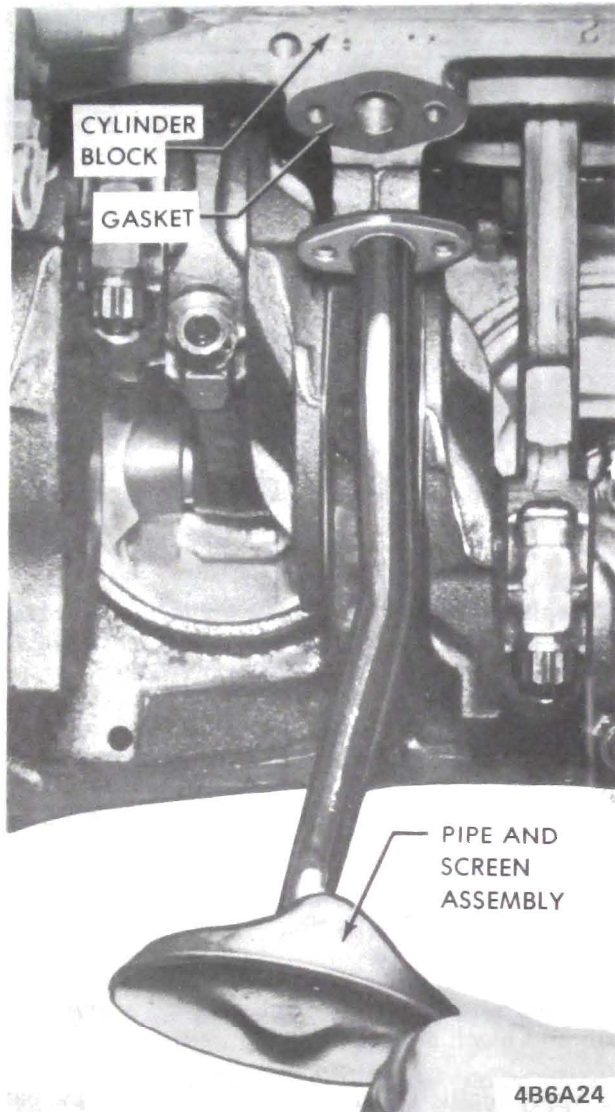

Figure 6A-73 - Oil Pickup Pipe and Screen

3. Install oil pan.

CONNECTING ROD BEARINGS

A connecting rod bearing consists of two halves or shells which are interchangeable in rod and cap. When the shells are placed in position, the ends extend slightly beyond the parting surfaces so that when the rod bolts are tightened the shells will be clamped tightly in place to insure positive seating and to prevent turning. *The ends of the bearing shells must never be filed flush with parting surface of rod or cap.*

If a rod bearing becomes noisy or is worn so that clearance on the crankpin is excessive, a new bearing of proper size must be selected and installed since no

provision is made for adjustment. *Under no circumstances should the connecting rod or cap be filled to adjust the bearing clearance.*

Inspection of Connecting Rod Bearings and Crankpin Journals

After removal of engine oil pan, disconnect two connecting rods at a time from crankshaft and inspect the bearings and crankpin journals. While turning crankshaft it is necessary to temporarily reconnect the rods to crankpin to avoid possibility of damaging the journals through contact with loose rods. Do not interchange rod caps with rods.

If connecting rod bearings are scored or show flaking, they should be replaced. If bearings are in good physical condition check for proper clearance on crankpin.

If crankpin journals are scored or ridged the crankshaft must be replaced, or reground for undersize bearings, to insure satisfactory life of connecting rod bearings. Slight roughness may be polished out with fine grit polishing cloth thoroughly wetted with engine oil. Burrs may be honed off with a fine oil stone.

Use an outside micrometer to check crankpins for out-of-round. If crankpins are more than .0015" out-of-round, satisfactory life of new bearings cannot be expected.

Checking Clearance and Selecting Replacement Bearings

Service bearings are furnished in standard size and several undersizes (including undersizes for reground crankpins).

The clearance of connecting rod (and crankshaft) bearings may be checked by use of Plastic-Type Gauge PG-1 which has a range of .001" to .003".

1. Remove connecting rod cap with bearing shell. Wipe oil from bearing and crankpin journal, also blow oil out of hole in crankshaft. Plastic-type gauge is soluble in oil.

2. Place a piece of plastic-type gauge lengthwise along the bottom center of the lower bearing shell (Figure 6A-74, View A), then install cap with shell and torque bolt nuts to 45 lb. ft. (455 Cu. In.) and 40 lb. ft. for (350 Cu. In.) capscrews.

NOTE: *Conical boss on web of rod (both 350 and 455) and rib on edge of 455 cap must be toward rear of engine on all rods in left bank and toward front of engine in right bank. Cap installation on 350 rod can be in only one direction since it is dictated by bolt centerline offset.*

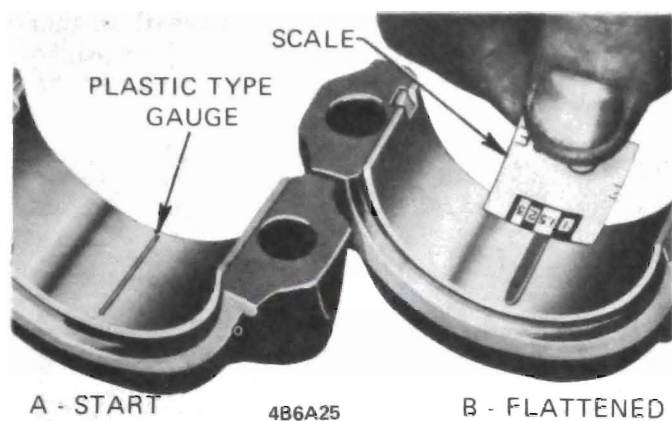

Figure 6A-74 - Checking Bearing Clearance With Plastic-Type Gauge

3. **DO NOT TURN CRANKSHAFT** with plastic-type gauge in bearing.

4. Remove bearing cap with bearing shell, the flattened plastic-type gauge will be found adhering to either the bearing shell or the crankpin. *Do not remove it.*

5. Using the scale printed on the plastic-type gauge envelope, measure the flattened plastic-type gauge at its widest point. The number within the graduation which most closely corresponds to the width of plastic-type gauge indicates the bearing clearance in thousandths of an inch. See Figure 6A-74, View B.

6. The desired clearance with a new bearing is .0002" to .0023". If bearing has been in service it is advisable to install a new bearing if the clearance exceeds .003"; however, if bearing is in good condition and

is not being checked because of bearing noise, it is not necessary to replace the bearing.

7. If a new bearing is being selected, try a standard size, then each undersize bearing in turn until one is found that is within the specified limits when checked for clearance with plastic-type gauge. Each undersize bearing shell has a number stamped on outer surface on or near the tang to indicate amount of undersize. See Figure 6A-75.

8. After the proper size bearing has been selected, clean off the plastic-type gauge, oil the bearing thoroughly, reinstall cap with bearing shell and torque bolt nuts to 45 lb. ft. (455 Cu. In.) and 40 lb. ft. for (350 Cu. In.) capscrews. See Note in Step 2.

9. With selected bearing installed and bolts tightened, it should be possible to move connecting rod freely back and forth on crankpin as allowed by end clearance. If rod cannot be moved, either the bearing is too much undersize or a misaligned rod is indicated.

CRANKSHAFT BEARINGS AND SEALS

Replacement of Crankshaft Bearings

A crankshaft bearing consists of two halves or shells which are not alike and not interchangeable in cap and crankcase. The upper (crankcase) half of the bearing is grooved to supply oil to the connecting rod bearings while the lower (bearing cap) half of the shell is not grooved. The two bearing halves must not be interchanged. All crankshaft bearings except the thrust bearing and rear main upper are identical. The thrust bearing (No. 3) is flanged to take end thrust and the rear main upper bearing groove does not extend the full length of the bearing. When the shells are placed in crankcase and bearing cap, the ends extend slightly beyond the parting surfaces so that when cap bolts are tightened the shells will be clamped tightly in place to insure positive seating and to prevent turning. *The ends of shells must never be filed flush with parting surface of crankcase or bearing cap.*

Crankshaft bearings are the precision type which do not require reaming to size. Shims are not provided for adjustment since worn bearings are readily replaced with new bearings of proper size. Bearings for service replacement are furnished in standard size and undersizes. *Under no circumstances should crankshaft bearing caps be filed to adjust for wear in old bearings.*

After removal of oil pan, pipe and screen assembly, and oil pan baffle, perform the following removal, inspection and installation operations on each crankshaft bearing in turn so that the crankshaft will be well supported by the other bearings



Figure 6A-75 - Location of Undersize Mark on Bearing Shell

If crankshaft has been removed to check straightness the following procedure is suggested.

Rest crankshaft on "V-blocks" at no. 1 and no. 5 main bearing journals. Check indicator runout at No. 2, 3, and 4 main bearing journals. Total indicator readings at each journal should not exceed .0015.

While checking runout at each journal note relation of "high" spot (for maximum eccentricity) on each journal to the others.

"High" spot on all journals should come at the same angular location. If "high" spots do not come at nearly the same angular location, crankshaft has a "crook" or "dogleg" in it and is unsatisfactory for service.

1. Since any service condition which affects the crankshaft bearings may also affect the connecting rod bearings, it is advisable to inspect connecting rod bearings first. If crankpins are worn to the extent that crankshaft should be replaced or reground, replacement of crankshaft bearings only will not be satisfactory. If replacement of cylinder block or crankshaft is required, always check main bearing clearance with plastic-type gauge to obtain specified limits.

2. Remove one bearing cap, then clean and inspect lower bearing shell and the crankshaft journal. If journal surface is scored or ridged, the crankshaft must be replaced or reground to insure satisfactory operation with new bearings. Slight roughness may be polished out with fine grit polishing cloth thoroughly wetted with engine oil, and burrs may be honed off with a fine stone.

3. If condition of lower bearing shell and crankshaft journal is satisfactory, check the bearing clearance with plastic-type gauge as described for the connecting rod bearing.

4. When checking a crankshaft bearing with plastic-type gauge, turn crankshaft so that oil hole is up to avoid dripping of oil on plastic-type gauge. Place paper shims in lower halves of adjacent bearings and tighten cap bolts to take the weight of crankshaft off the lower shell of bearing being checked. Arrow on cap must point to front of engine.

5. If bearing clearance exceeds .003", it is advisable to install a new bearing; however, if bearing is in good condition and is not being checked because of bearing noise, it is not necessary to replace the bearing.

6. Loosen all crankshaft bearing cap bolts 1/2 turn, and remove cap of bearing to be replaced.

7. Remove upper bearing shell by inserting Bearing Shell Remover and Installer J-8080 in oil hole in

crankshaft, then slowly turning crankshaft so that the tool rotates the shell out of place by pushing against the end without the tang. See Figure 6A-76.

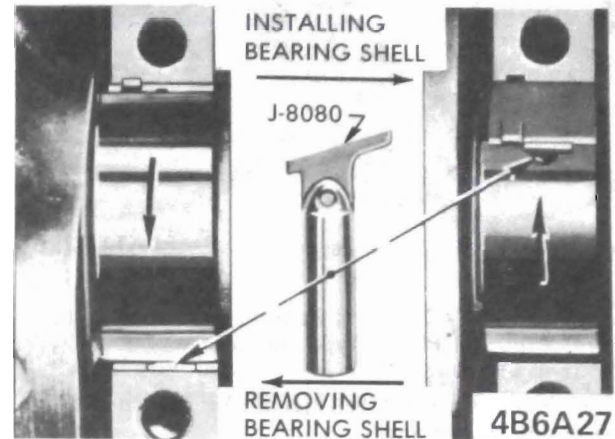

Figure 6A-76 - Removal and Installation of Crankshaft Bearing Upper Shell

When turning crankshaft with rear bearing cap removed, hold oil seal to prevent it from rotating out of position in crankcase.

8. The crankshaft journal cannot be measured with an outside micrometer when shaft is in place; however, when upper bearing shell is removed the journal may be checked for out-of-round by using a special crankshaft caliper and inside micrometer. The caliper should not be applied to journal in line with oil hole.

If crankshaft journal is more than .0015" out-of-round, the crankshaft should be replaced since the full mileage cannot be expected from bearings used with an excessively out-of-round crankshaft.

9. Before installation of bearing shells make sure that crankshaft journal and the bearing seats in crankcase and cap are thoroughly cleaned.

10. Coat inside surface of upper bearing shell with engine oil and place shell against crankshaft journal so that tang on shell will engage notch in crankcase when shell is rotated into place. Upper bearing shells have an oil groove in their center, while lower shells are not grooved. They must not be interchanged.

11. Rotate bearing shell into place as far as possible by hand, then insert Installer J-8080 in crankshaft oil hole and rotate crankshaft to push shell into place. Bearing shells should move into place with very little pressure. If heavy pressure is required, shell was not started squarely and will be distorted if forced into place.

12. Place lower bearing shell in bearing cap, then check clearance with plastic-type gauge, as previously described.

13. The desired clearance with a new bearing is .0004" to .0015" (350 Cu. In.) and .0007" to .0018" (455 cu. in.). If this clearance cannot be obtained with a standard size bearing, insert an undersize bearing and check again with plastic-type gauge.

Each undersize shell has a number stamped on outer surface on or near the tang to indicate amount of undersize.

14. When the proper size bearing has been selected, clean out all plastic-type gauges, oil the lower shell and reinstall bearing cap. Clean the bolt holes and lube bolts, then torque cap bolts to specification.

The crankshaft should turn freely at flywheel rim; however, a very slight drag is permissible.

15. If the *thrust* bearing shell is disturbed or replaced it is necessary to line up the thrust surfaces of the bearing shell before the cap bolts are tightened. To do this, move the crankshaft fore and aft the limit of its travel several times (last movement fore) with the thrust bearing cap bolts finger tight.

16. After bearing is installed and tested, loosen all bearing cap bolts 1/2 turn and continue with other bearings. When bearings have been installed and tested, tighten all bearing cap bolts to specified torque (350 engine 115 lb.ft., 455 engine 115 lb.ft.).

17. Replace rear main bearing oil seals.

18. Install oil pan baffle, pipe and screen assembly, and oil pan.

Installation of Rear Bearing Oil Seals

Braided fabric seals are pressed into grooves formed in crankcase and rear bearing cap to rear of the oil

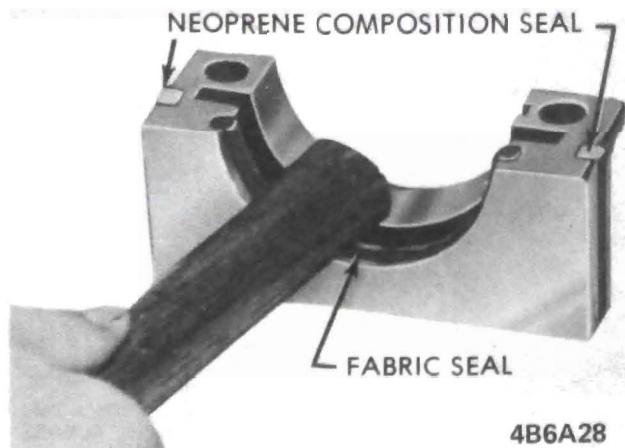

Figure 6A-77 - Installing Rear Bearing Oil Seals (350 Cu. In.)

collecting groove, to seal against leakage of oil around the crankshaft. See Figure 6A-77 or 6A-78.

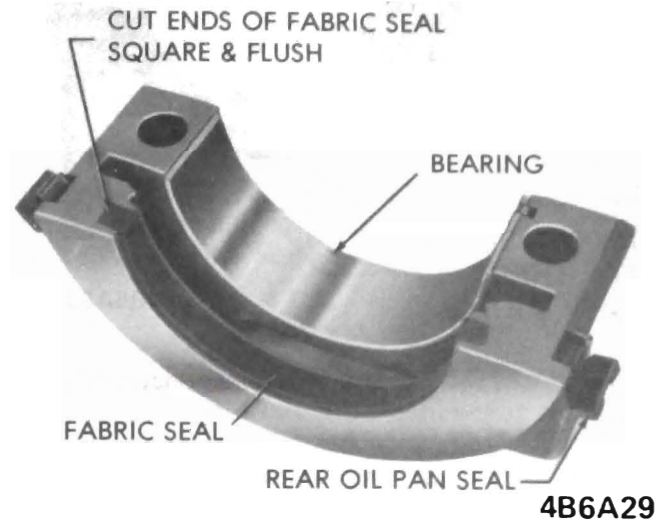

Figure 6A-78 - Rear Bearing Oil Seal (455 Cu. In.)

A new braided fabric seal can be installed in crankcase only when crankshaft is removed, but it can be repaired while crankshaft is installed, as outlined under Rear Main Bearing Upper Oil Seal Repair. The seal can be replaced in cap whenever the cap is removed. Remove old seal and place new seal in groove with both ends projecting above parting surface of cap. Force seal into groove by rubbing down with hammer handle or smooth stick until seal projects above the groove not more than 1/16". Cut ends off flush with surface of cap, using sharp knife or razor blade. See Figure 6A-77 or 6A-78.

The engine must be operated at slow speed when first started after a new braided seal is installed.

Neoprene composition seals (350 cu.in. only) are placed in grooves in the sides of bearing cap to seal against leakage in the joints between cap and crankcase. The neoprene composition swells in the presence of oil and heat. The seals are undersize when newly installed and may even leak for a short time until the seals have had time to swell and seal the opening. See Figure 6A-77.

The neoprene seals are slightly longer than the grooves in the bearing cap. The seals must not be cut to length. Before installation of seals, soak for 1 to 2 minutes in light oil or kerosene. After installation of bearing cap in crankcase, install seal in bearing cap.

To help eliminate oil leakage at the joint where the cap meets the crankcase, apply silastic sealer to the rear main bearing cap split line. When applying sealer, use only a thin coat as an over abundance will not allow the cap to seal properly. See Figure 6A-79.

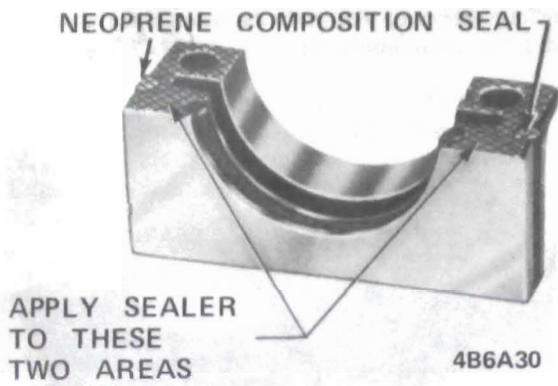

Figure 6A-79 (350 Engine) Sealer Applied to Split Line

After seal is installed, force seals up into the cap with a blunt instrument to be sure of a seal at the upper parting line between the cap and case.

Rear Main Bearing Upper Oil Seal Repair

1. Remove oil pan.
2. Insert packing tool (J-21526-2) against one end of the seal in the cylinder block. Drive the old seal gently into the groove until it is packed tight. This varies from 1/4" to 3/4" depending on the amount of pack required. See Figure 6A-80.

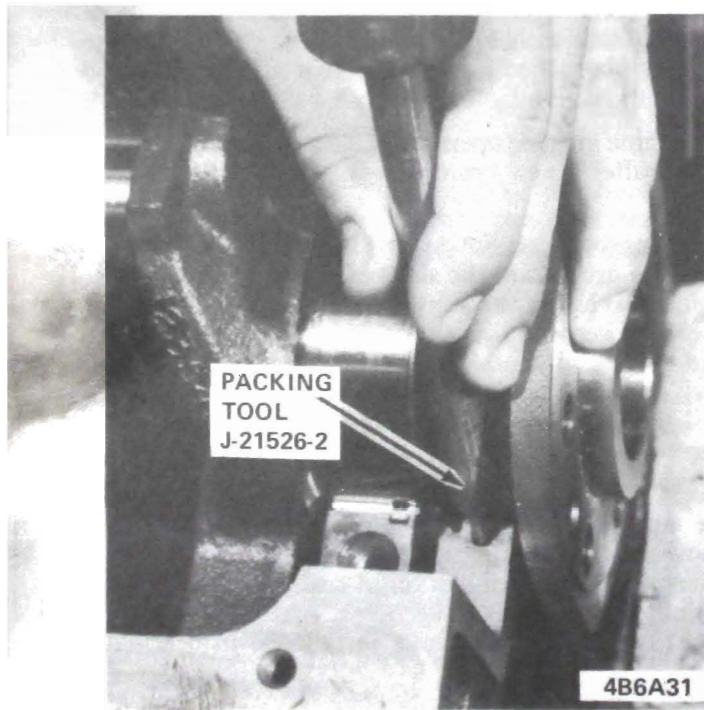

Figure 6A-80 Packing Seal into Cylinder Block

3. Repeat Step 2 on the other end of the seal in the cylinder block.

4. Measure the amount the seal was driven up on one side and add 1/16", using a single edge razor blade cut that length from the old seal removed from the rear main bearing cap. Repeat the procedure for the other side. Use the rear main bearing cap as a holding fixture when cutting the seal.

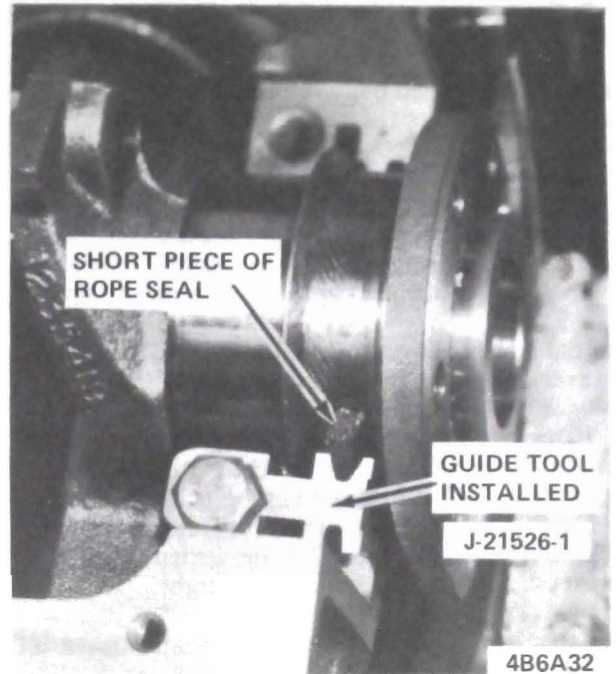

Figure 6A-81 Guide Tool Installed

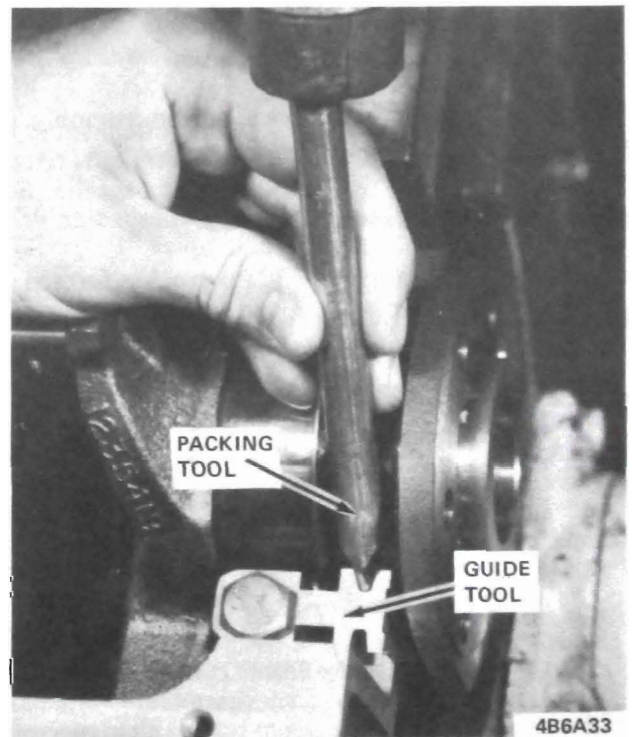

Figure 6A-82 Packing Short Pieces of Rope Seal into Guide Tool and Cylinder Block

5. Install Guide Tool (J-21526-1) onto cylinder block. See Figure 6A-81.

6. Using packing tool, work the short pieces cut in Step 4 into the guide tool and then pack into cylinder block. The guide tool and packing tool have been machined to provide a built-in stop. Use this procedure for both sides. See Figures 6A-81 and 6A-82.

NOTE: It may help to use oil on the short pieces of the rope seal when packing into the cylinder block.

7. Remove the guide tool.

8. Install a new fabric seal in the rear main bearing cap. Install cap and torque to specifications.

9. Install oil pan.

PISTONS, RINGS, AND CONNECTING RODS

Replacement, Disassembly, and Inspection of Piston and Rod Assemblies

1. Remove cylinder heads.

2. Examine the cylinder bores above the ring travel. If bores are worn so that a shoulder or ridge exists at the top of the cylinder, remove the ridges with a ridge reamer to avoid damaging rings or cracking ring lands in pistons during removal. See Figure 6A-83.

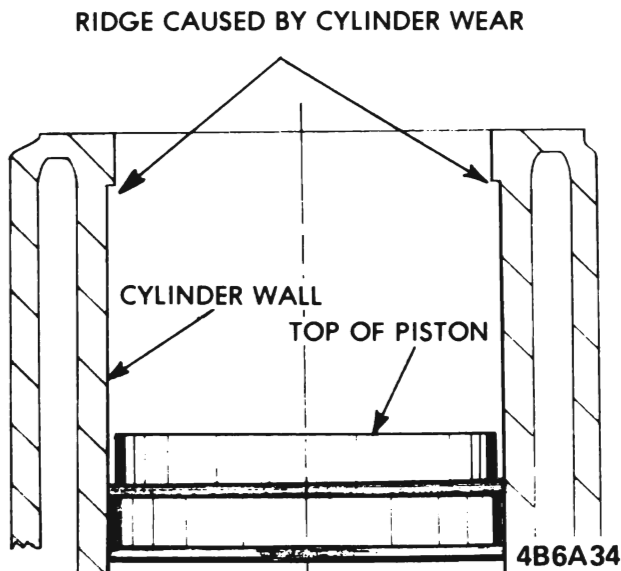

Figure 6A-83 - Ridge Formed by Rings at Top of Travel

3. Use a silver pencil or quick drying paint to mark the cylinder number on all pistons, connecting rods and caps. Starting at the front end of the crankcase the cylinders in the right bank are numbered 2-4-6-8. Those in the left bank are numbered 1-3-5-7.

4. To remove piston and rod assemblies:

455 Cu. In.

With No. 1 crankpin straight down, remove the cap with bearing shell from No. 1 connecting rod, install the *short* Connecting Rod Bolt Guide J-5239-1 on the connecting rod bolt, above crankpin. Install the *long* Connecting Rod Bolt Guide J-5239-2 on remaining stud. Turn guides down fully to hold the upper bearing shell in place while removing piston and rod assembly. See Figure 6A-84.

350 Cu. In.

With No. 1 crankpin straight down, remove the cap with bearing shell from No. 1 connecting rod, install the "short" connecting rod guide Tool J-24567-1 in the connecting rod hole above the crankpin. Install the "long" connecting rod guide Tool J-24567-2 in remaining hole. Turn guides down fully to hold the upper bearing shell in place while removing the piston and rod assembly.

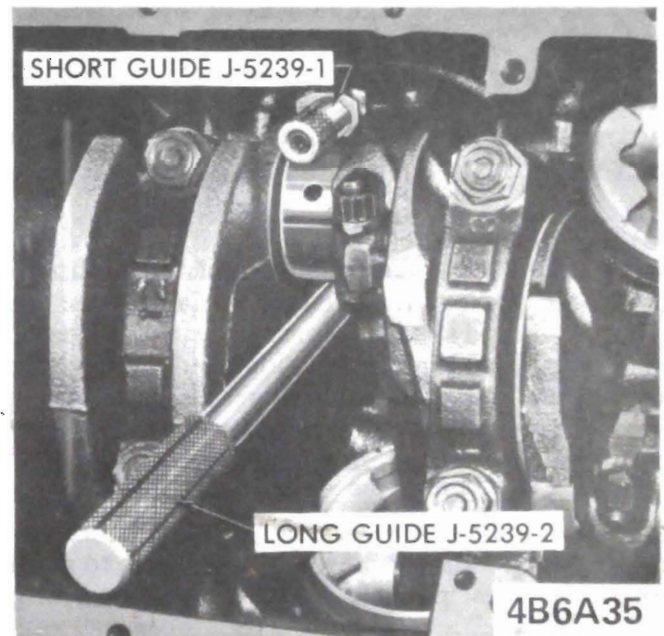

Figure 6A-84 - Connecting Rod Bolt Guides Installed

5. Use the long guide to push the piston and rod assembly out of the cylinder, then remove guides and reinstall cap with bearing shell on rod.

6. Remove all other piston and rod assemblies in the same manner.

7. Remove compression rings and remove oil ring.

8. To remove piston pin:

455 Engine

(a) Place piston and rod assembly in press, using

Piston Support J-6047-17 (with full radial face up) under the piston.

(b) Place Drive Pin J-6047-4 in upper end of piston pin.

(c) Press pin from rod and piston.

350 Engine

(a) Place piston and rod assembly in press, using Piston Support J-6047-5 (with full radial face up) under the piston.

(b) Place Drive Pin J-6047-4 in upper end of piston.

(c) Press pin from rod and piston.

9 (a) Inspect cylinder walls for scoring, roughness, or ridges which indicate excessive wear. Check cylinder bores for taper and out-of-round with an accurate cylinder gauge at top, middle and bottom of bore, both parallel and at right angles to the centerline of the engine. The diameter of the cylinder bores at any point may be measured with an inside micrometer or setting the cylinder gauge dial at "O" and measuring across the gauge contact points with outside micrometer while the gauge is at same "O" setting.

(b) If a cylinder bore is moderately rough or slightly scored but is not out-of-round or tapered, it is usually possible to remedy the situation by honing the bore to fit a standard service piston since standard service pistons are high limit production pistons. If cylinder bore is very rough or deeply scored, however, it may be necessary to rebore the cylinder to fit an oversize piston in order to insure satisfactory results.

(c) If cylinder bore is tapered .005" or more or is out-of-round .003" or more, it is advisable to rebore for the smallest possible oversize piston and rings.

10. Clean carbon from piston surfaces and under side of piston heads. Clean carbon from ring grooves with suitable tool and remove any gum or varnish from piston skirts with suitable solvent.

11. Carefully examine pistons for rough or scored bearing surfaces, cracks in skirt or head cracked or broken ring lands, chipping or uneven wear which would cause rings to seat improperly or have excessive clearance in ring grooves. Damaged or faulty pistons should be replaced.

The pistons are cam ground, which means that the diameter at a right angle to the piston pin is greater than the diameter parallel to the piston pin. When a piston is checked for size, it must be measured with micrometers applied to the skirt at points 90 degrees to the piston pin. See Figure 6A-85. The piston

should be measured (for fitting purposes) 1/4" below the bottom of the oil ring groove.

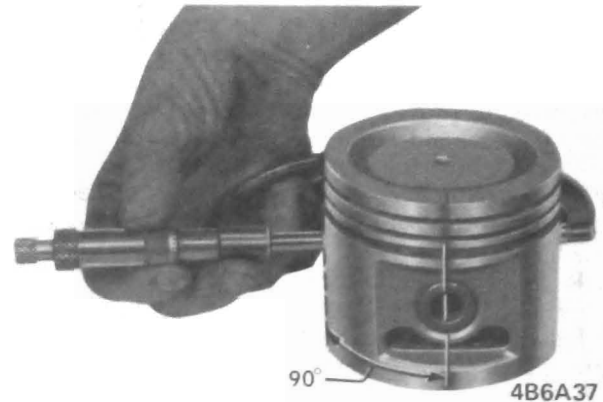

Figure 6A-85 - Measuring Piston

12. Inspect bearing surfaces of piston pins and check for wear by measuring worn or unworn surfaces with micrometers. Rough or worn pins should be replaced. Test fit piston pins in piston bosses. Occasionally pins will be found tight due to gum or varnish deposits. This may be corrected by removing the deposit with a suitable solvent. If piston bosses are worn out-of-round or oversize, the piston and pin assembly must be replaced. Oversize pins are not practical due to the pin being a press fit in the connecting rod. Piston pins must fit the piston with an easy finger push at 70 degrees F (.0004" to .0007" clearance).

13. Examine all piston rings for scores, chips or cracks. Check compression rings for tension by comparing with new rings. Check gap of compression rings by placing rings in bore at bottom of ring travel. Measure gap with feeler gauge. Gap should be between .010" and .020". If gaps are excessive (over .020") it indicates the rings have worn considerably and should be replaced. Bore wear should be checked before rings are replaced, .005" bore wear will result in .015" increase in ring gap.

Reboring Cylinder and Fitting New Pistons

If one or more cylinder bores are rough, scored, or worn beyond limits, it will be necessary to smooth or true up such bores to fit new pistons.

If relatively few bores require correction it will not be necessary to rebore all cylinders to the same oversize in order to maintain engine balance, since all oversize service pistons are held to the same weights as standard size pistons. If conditions justify replacement of all pistons, however, all new pistons should be the same nominal size.

Standard size service pistons are high limit or maximum diameter; therefore, they can usually be used

with a slight amount of honing to correct slight scoring or excessive clearances in engines having relatively low mileage. All service pistons are diamond bored and selectively fitted with piston pins; pistons are not furnished without pins.

No attempt should be made to cut down oversize pistons to fit cylinder bores as this will destroy the surface treatment and affect the weight. The smallest possible oversize service pistons should be used and the cylinder bores should be honed to size for proper clearances.

Before the honing or reboring operation is started, measure all new pistons with micrometer contacting at points exactly 90 degrees to piston pin (Figure 6A-85) then select the smallest piston for the first fitting. The slight variation usually found between pistons in a set may provide for correction in case the first piston is fitted too free.

If wear at top of cylinder does not exceed .005" on the diameter or exceed .003" out-of-round, honing is recommended for truing the bore. If wear or out-of-round exceeds these limits, the bore should be trued up with a boring bar of the fly cutter type, then finish honed.

When reboring cylinders, all crankshaft bearing caps must be in place and tightened to proper torque to avoid distortion of bores in final assembly. Always be sure the crankshaft is out of the way of the boring cutter when boring each cylinder. When taking the final cut with boring bar leave .001" on the diameter for finish honing to give the required clearance specified below.

When honing cylinders use clean sharp stones of proper grade for the amount of metal to be removed, in accordance with instructions of the hone manufacturer. Dull or dirty stones cut unevenly and generate excessive heat. When using coarse or medium grade stones use care to leave sufficient metal so that all stone marks may be removed with the fine stones used for finishing to provide proper clearance.

When finish honing, pass the hone through the entire length of cylinder at the rate of approximately 60 cycles per minute. This should produce the desired 45 degree cross hatch pattern on cylinder walls which will insure maximum ring life and minimum oil consumption.

It is of the greatest importance that refinished cylinder bores are trued up to have not over .0005" out-of-round or taper. Each bore must be final honed to remove all stone or cutter marks and provide a smooth surface. During final honing, each piston must be fitted individually to the bore in which it will be installed and should be marked to insure correct installation.

After final honing and before the piston is checked for fit, each cylinder bore must be *thoroughly* washed to remove all traces of abrasive and then dried thoroughly. The dry bore should then be brushed clean with a power-driven fibre brush. If all traces of abrasive are not removed, rapid wear of new pistons and rings will result. A satisfactory method of fitting pistons is as follows:

1. Expand a telescope gauge to fit the cylinder bore at right angles to the piston pin and between 1-1/2" and 2" from the top. See Figure 6A-86.

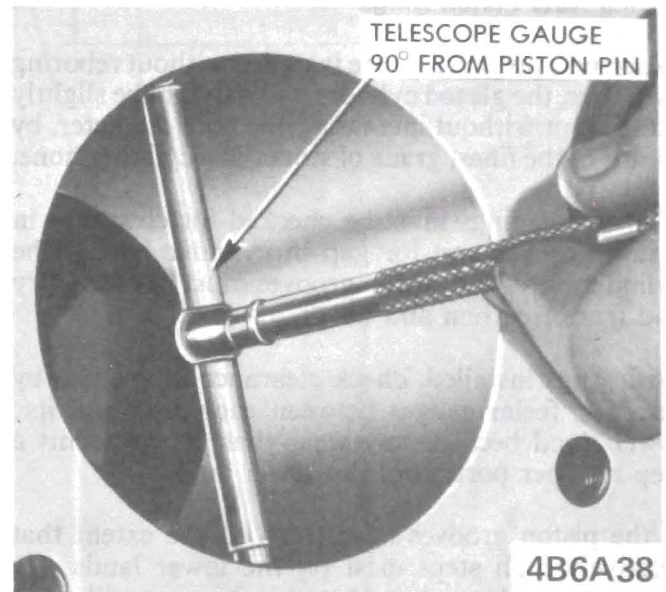

Figure 6A-86 - Checking Cylinder Bore

2. Measure the telescope gauge. See Figure 6A-87.

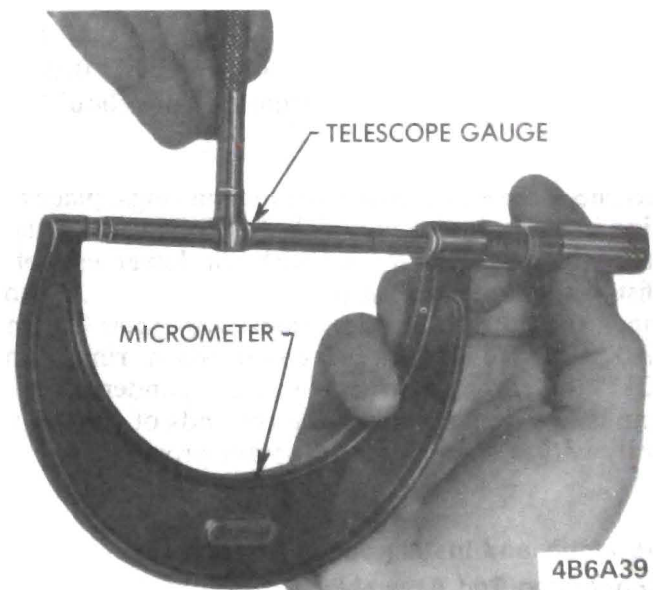

Figure 6A-87 - Measuring Telescope Gauge

3. Measure the piston to be installed. See Figure 6A-85. The piston must be measured at right angles to the piston pin 1/4" below the oil ring groove. The

piston must be between .0008" and .0014" (350 Cu. In.) and .0007" to .0013" (455 Cu. In.) smaller than the cylinder bore.

NOTE: Measurements should be made at $70^{\circ}\text{F} \pm 15^{\circ}$.

Both block and piston must be at very nearly the same temperature when measurements are made or errors due to expansion will occur. A difference of 10 degrees F. between parts is sufficient to produce a variation of .0005".

Fitting New Piston Rings

When new piston rings are installed without reboring cylinders, the glazed cylinder walls should be slightly dulled, but without increasing the bore diameter, by means of the finest grade of stones in a cylinder hone.

New piston rings must be checked for clearance in piston grooves and for gap in cylinder bores. The cylinder bores and piston grooves must be clean, dry and free of carbon and burrs.

With rings installed, check clearance in grooves by inserting feeler gauges between each ring and its lower land because any wear that occurs forms a step at inner portion of the lower land.

If the piston grooves have worn to the extent that relatively high steps exist on the lower lands, the piston should be replaced because the steps will interfere with the operation of new rings and the ring clearances will be excessive. Piston rings are not furnished in oversize widths to compensate for ring groove wear.

When fitting new rings to new pistons the side clearance of the compression rings should be .003" to .005" and side clearance of the oil ring should not exceed .0035".

To check the end gap of compression rings, place the ring in the cylinder in which it will be used, square it in the bore by tapping with the lower end of a piston, then measure gap with feeler gauges. Piston rings should not have less than .010" (350 Cu. In.) and .013" (455 Cu. In.) (compression rings) and .015" (oil ring) gap when placed in cylinder bores. If gap is less than specified, file the ends of rings carefully with a smooth file to obtain proper gap.

Assembly and Installation of Piston and Connecting Rod Assemblies

Connecting rods may be sprung out of alignment in shipping or handling. Always check a new rod before installing piston and pin.

Check bend and twist on an accurate rod aligning

fixture using Guide Pin J-6047-16 for 455 engines, and J-6047-20 for 350 engines, in place of wrist pin. Press V-block firmly and evenly against guide pin to prevent cocking pin in eye of rod which may be up to .00125" tight on pin.

1. To assemble piston and pin to connecting rod, first place Piston Pin Spacer, J-6047-21, and Piston Support, J-6047-17, or J-6047-5 whichever applies, in base plate of press.

2. If the piston and rod assembly is to be installed in the *left* bank, the assembly must be made as shown in Figures 6A-88 and 6A-91.

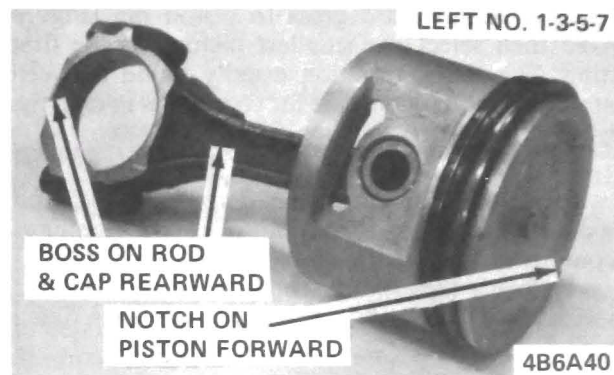

Figure 6A-88 Left Bank Piston and Rod Assembly (455 Cu. In. Engine)

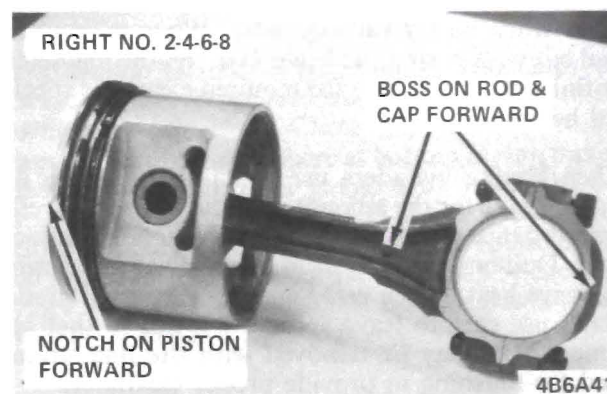

Figure 6A-89 - Right Bank Piston and Rod Assembly (455 Cu. In. Engine)

3. If the piston and rod assembly is to be installed in the *right* bank, the assembly must be made as shown in Figures 6A-89 and 6A-90.

4. Lubricate piston pin to avoid damage when pressing into connecting rod.

5. Assemble piston and rod on spring loaded guide pin.

6. Install drive pin in upper end of piston pin. Press on drive pin till piston pin bottoms.

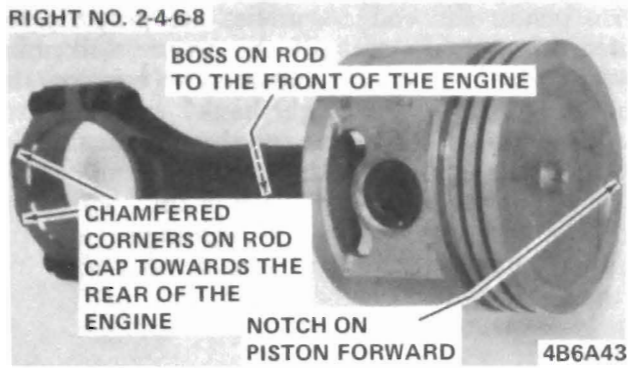

Figure 6A-90 - Right Bank Piston and Rod Assembly (350 Cu. In. Engine)

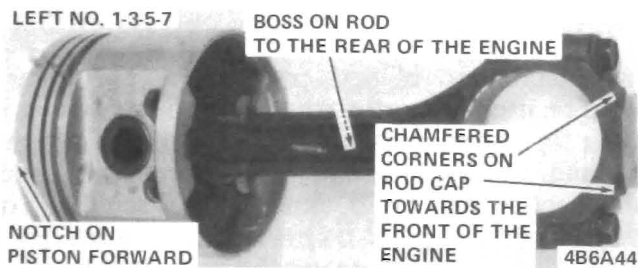

Figure 6A-91 - Left Bank Piston and Rod Assembly (350 Cu. In. Engine)

7. Remove piston and rod assembly from press. Rotate piston on pin to be sure pin was not damaged during the pressing operation.

8. Install piston rings as shown in Figures 6A-92. Position expander ends over piston pin. Install oil ring rail spacer, and oil ring rails. Position gaps in rails so that when piston is installed in its bore the gap will point toward the camshaft. Install compression rings in upper two grooves.

a. Top compressing ring - When installed, the manufacturer's identification mark ("O", "DOT" or "TOP") facing up.

b. Second compression ring - When installed, the manufacturer's identification mark ("O", "DOT" or "TOP") facing up.

c. Oil ring - Can be installed with either rail facing up. 350 engines have a 2 piece oil ring, which has only one rail. The rail must be installed at the top of the oil ring groove.

d. Ring gaps - All three ring gaps must be 90 degrees apart. See Figure 6A-92.

9. Make sure cylinder bores, pistons, connecting rod bearings and crankshaft journals are absolutely clean, then coat all bearing surfaces with engine oil.

10. Before installation of a piston and rod assembly in its bore, position the crankpin straight down.

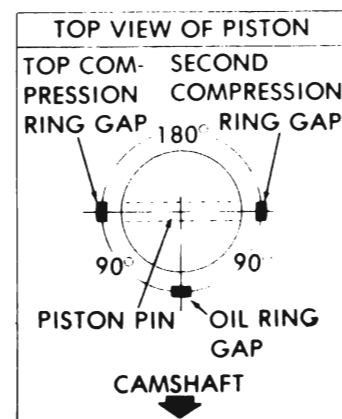
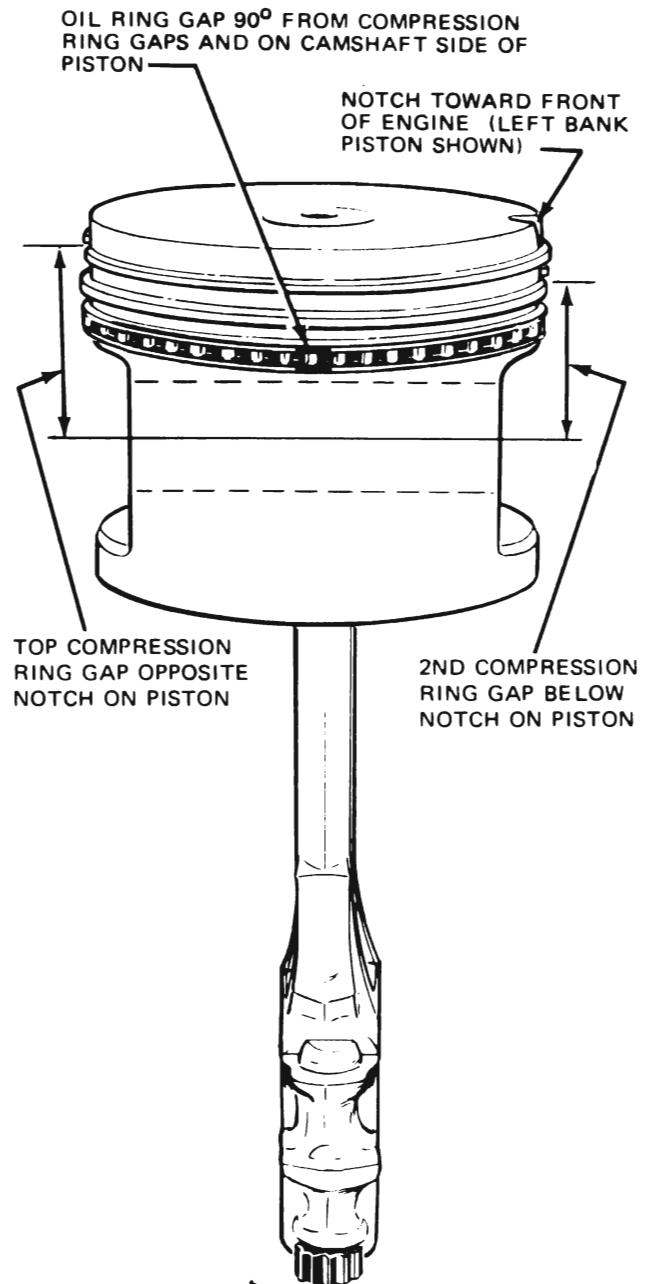

4B6A46

Figure 6A-92 - Piston Ring Gap Positioning

11. Remove cap, and with bearing upper shell seated in connecting rod, install the *long* Guide J-5239-2

or (J-24567-1 for capscrew rods) on bolt which is on same side of rod as the notch for the tang of the bearing insert. Install short Guide J-5239-1 or (J-24567-2 for capscrew rods) on the other connecting rod bolt.

These guides hold the upper bearing shell in place and protect the crankpin journal from damage during installation of connecting rod and piston assembly.

12. Make sure the gap in the oil ring rails is "up" position toward center of engine and the gaps of the compression rings are positioned as shown in Figure 6A-93.

13. Lubricate the piston and rings and install in bore by compressing the rings either with a "wrap around" compressor or a ring type such as shown in Figure 6A-93.

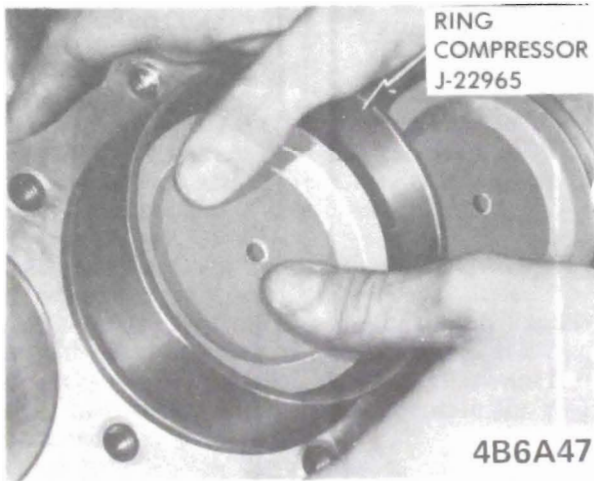

Figure 6A-93 - Installing Piston with Ring Compressor Installed (350 Shown)

14. Select new connecting rod bearing, if necessary. Otherwise install cap with bearing lower shell on rod and tighten bolt nuts to 45 lb. ft. (455 Cu. In.) and 40 lb. ft. for (350 Cu. In.) cap screws.

15. Install all other piston and rod assemblies in the same manner:

455 Cu. In.

When piston and rod assemblies are properly installed, all notches on the pistons will point towards the front of the engine and the boss on the connecting rod and caps will point towards the front of the engine for the right bank and towards the rear of the engine for the left bank. See Figures 6A-88 and 6A-89.

b. 350 Cu. In.

When piston and rod assemblies are properly installed, the notches on "all" the pistons will point towards the front of the engine. The boss on the connecting rods in the "right bank" will point towards the front of the engine and the chamfers on the rod caps will point towards the rear of the engine. The boss on the connecting rods in the "left bank" will point towards the rear of the engine and the chamfers on the rod caps will point towards the front of the engine. See Figures 6A-90 and 6A-91. 16. Check end clearance between connecting rods on each crankpin using feeler gauges. Clearance should be between .005" and .019" for the 455 engine and between .006 - .020 for the 350 engine.

17. Install cylinder head. Install oil screen and engine oil pan.

After installation of new pistons and rings, care should be used in starting the engine and running it for the first hour. Avoid high speeds until the parts have had a reasonable amount of "break in" time. This practice will avoid unnecessary "scuffing" of new parts.

CAMSHAFT AND TIMING CHAIN

Timing Chain Cover Removal

1. Drain radiator.
2. Disconnect upper and lower radiator hose and heater return hose at water pump, disconnect lower bolts and brackets and remove radiator.
3. Remove fan, fan pulleys and belt(s).
4. Remove fan driving pulley (crankshaft).
5. Disconnect fuel lines and remove fuel pump.
6. Remove Delcotron generator and brackets.
7. Remove distributor cap and pull spark plug wire retainers off brackets on rocker arm cover. Swing distributor cap with wires attached out of the way. Disconnect distributor primary lead.
8. Remove distributor. If timing chain and sprockets are not going to be disturbed, note position of distributor rotor for reinstallation in same position.
9. Loosen and slide front clamp on thermostat bypass hose rearward.
10. Remove harmonic balancer bolt and washer and remove harmonic balancer.
11. Remove bolts attaching timing chain cover to cylinder block. See Figures 6A-94 and 6A-95. Remove two oil pan to timing chain cover bolts 350

Cu. In. and 4 bolts on the 455 Cu. In. Remove timing chain cover assembly and gasket. Thoroughly clean the cover, taking care to avoid damage to the gasket surface.

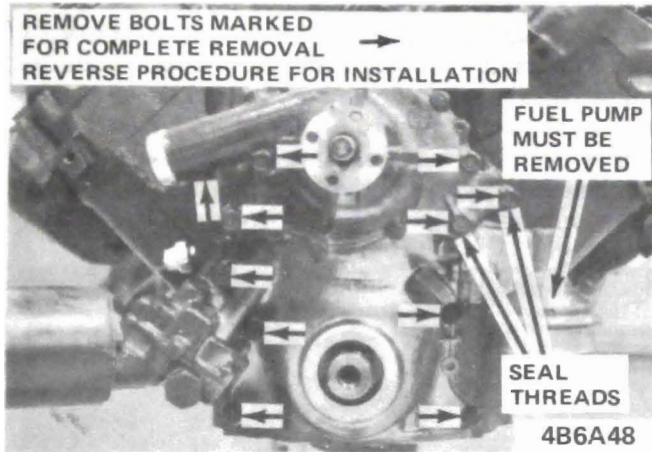

Figure 6A-94 - Timing Chain Cover Removal and Installation (350 cu.in.)

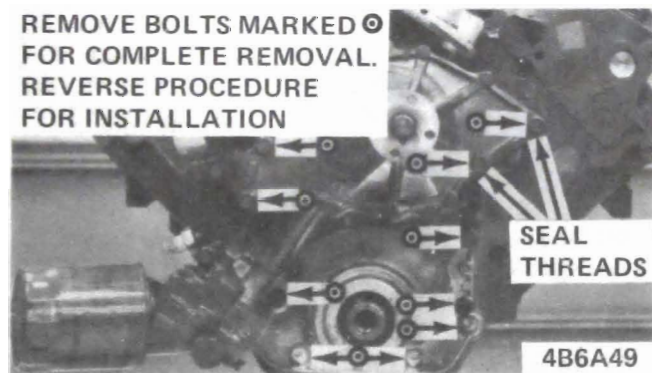

Figure 6A-95 - Timing Chain Cover Removal and Installation (455 cu.in.)

Timing Chain Cover Replacement

Reinstall timing chain cover by reversing removal procedure, paying particular attention to the following points.

1. Remove oil pump cover and pack the space around the oil pump gears completely full of petroleum jelly. There must be no air space left inside the pump. Reinstall cover using new gasket. This step is very important as the oil pump may "lose its prime" whenever the pump, pump cover or timing chain cover is disturbed. If the pump is not packed, it may not begin to pump oil as soon as the engine is started.

2. The gasket surface of the block and timing chain cover must be smooth and clean. Use a new gasket and be certain it is positioned correctly.

3. Position timing chain cover against block and be certain dowel pins engage dowel pin holes before starting bolts.

4. Apply sealer to bolt threads as shown in Figures 6A- 48 and 6A-95.

5. Install harmonic balancer, bolt and washer. By using a screwdriver or other suitable tool, lock flywheel and torque bolt to (140-160 lb. ft. on 350 cu.in.) and (200-220 lb. ft. on 455 cu.in.) See Figure 6A-96.

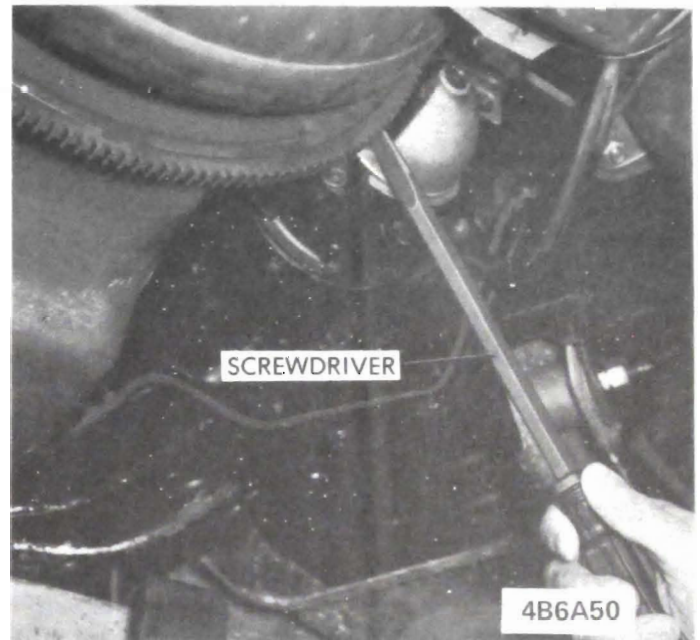

Figure 6A-96 - Locking Flywheel to Torque Harmonic Balancer Bolt.(350 cu.in. Shown)

Front Crankshaft Oil Seal Replacement

1. Use a punch to drive out old seal and shedder. Drive from the front toward the rear of the timing chain cover.

2. Coil new packing around opening so ends of packing are at top. Drive in shedder using suitable punch. Stake the shedder in place in at least three places.

3. Size the packing by rotating a hammer handle or similar tool around the packing until the balancer hub can be inserted through the opening.

Timing Chain and Sprocket Removal

350 Cu. In.

1. With timing chain cover removed temporarily install harmonic balancer bolt and washer in end of crankshaft. Turn crankshaft so sprockets are positioned as shown in Figure 6A-97. Remove harmonic balancer bolt and washer using a sharp blow on the wrench handle, so that the bolt can be started out without changing position of sprockets.

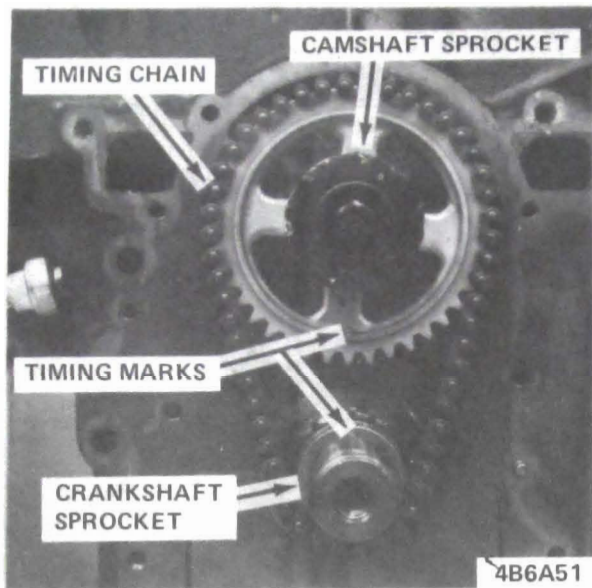

Figure 6A-97 - Installation of Timing Chain and Sprocket - 350 Cu. In.

2. Remove front crankshaft oil slinger.
3. Remove bolt and special washer retaining camshaft distributor drive gear and fuel pump eccentric to camshaft forward end. Slide gear and eccentric off camshaft. See Figure 6A-98.

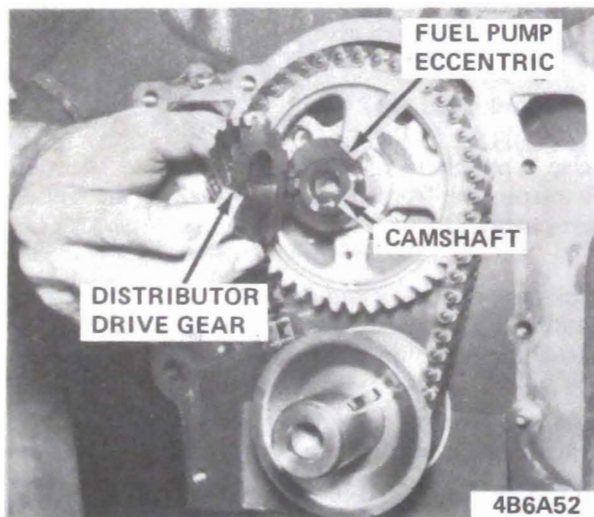

Figure 6A-98 - Fuel Pump and Distributor Drive Gear Installation - 350 Cu. In.

4. Use two large screwdrivers to alternately pry the camshaft sprocket then the crankshaft sprocket forward until the camshaft sprocket is free, then remove the camshaft sprocket and chain and finish working crankshaft sprocket off crankshaft.

5. Thoroughly clean the timing chain, sprockets, dis-

tributor drive gear, fuel pump eccentric and crankshaft oil slinger.

455 Cu. In.

1. With timing chain cover removed, temporarily install harmonic balancer bolt and washer in end of crankshaft. Turn crankshaft so sprockets are positioned as shown in Figure 6A-99. Remove harmonic balancer bolt and washer using a sharp blow on the wrench handle, so that the bolt can be started out without changing position of sprockets.

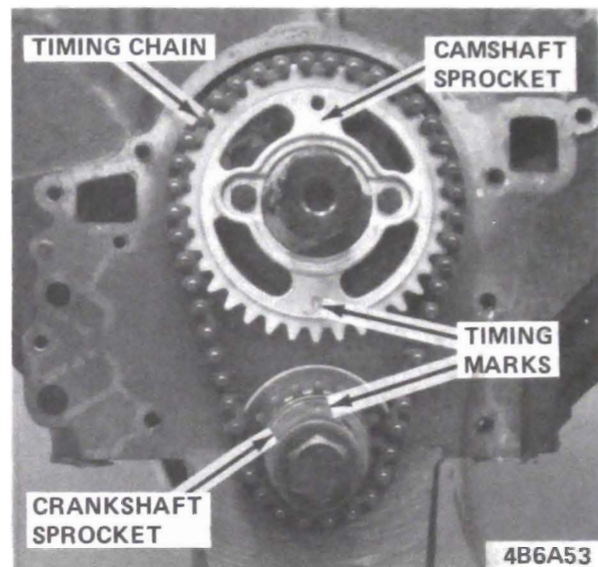

Figure 6A-99 - Installation of Timing Chain and Sprocket (455 cu.in.)

2. Remove oil pan.
3. Remove front crankshaft oil slinger.
4. Remove camshaft sprocket bolts.
5. Use two large screwdrivers to alternately pry the camshaft sprocket then the crankshaft sprocket forward until the camshaft sprocket is free, then remove the camshaft sprocket and chain and finish working crankshaft sprocket off crankshaft.
6. Thoroughly clean the timing chain, sprockets, distributor drive gear, fuel pump eccentric and crankshaft oil slinger.

Timing Chain and Sprocket Installation

350 Cu. In.

1. Turn crankshaft so that Number 1 piston is at top dead center.

2. Turn camshaft so with sprocket temporarily installed, timing mark is straight down. See Figure 6A-97. Remove Sprocket.

3. Assemble timing chain on sprockets and slide the sprocket and chain assembly on the shafts with the timing marks in their closest together position and in line with the sprocket hubs. See Figure 6A-97.

4. Assemble slinger on crankshaft with I.D. against sprocket (concave side toward front of engine). See Figure 6A-100.

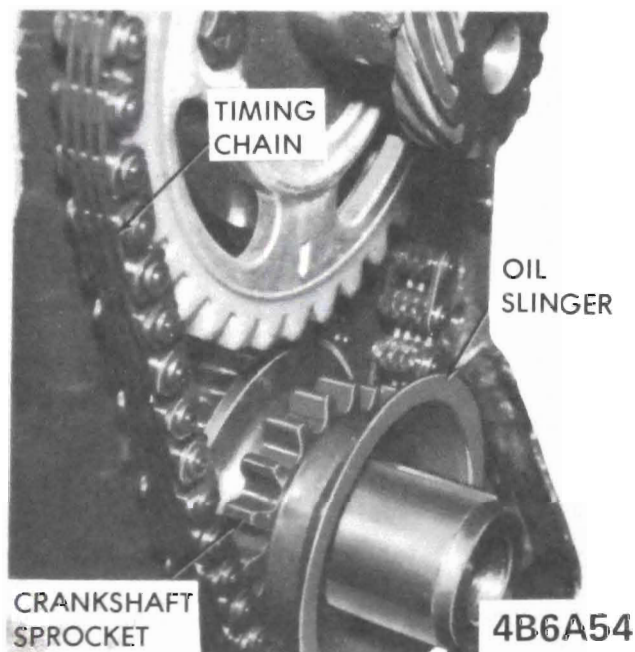

Figure 6A-100 - Oil Slinger Installation

5. Slide fuel pump eccentric on camshaft with oil groove out board of keyway towards front of engine. See Figure 6A-98.

6. Install distributor drive gear. See Figure 6A-98.

7. Install drive gear and eccentric bolt and retaining washer. Torque to 50 lb. ft.

8. Reinstall timing chain cover.

455 Cu. In.

1. Turn crankshaft so that Number 1 piston is at top dead center.

2. Turn camshaft so with sprocket temporarily installed, timing mark is straight down. See Figure 6A-99. Remove sprocket.

3. Assemble timing chain on sprockets and slide the sprocket and chain assembly on the shafts with the timing marks in their closest together position and in line with the sprocket hubs. See Figure 6A-99.

4. Assemble slinger on crankshaft with I.D. against sprocket (concave side toward front of engine). See Figure 6A-100.

5. Reinstall oil pan using a new gasket.

6. Install camshaft sprocket bolts. Torque to 22 lb. ft.

7. Reinstall timing chain cover.

Camshaft Service

1. Remove intake manifold.

2. Remove rocker arm covers.

3. Remove rocker arm and shaft assemblies, push rods and valve lifters.

4. Remove timing chain cover, timing chain and sprocket.

5. Slide camshaft forward out of bearing bores carefully to avoid marring the bearing surfaces.

6. When replacing camshaft, take particular care to avoid marring the bearing surfaces.

7. Install valve mechanism.

8. Install intake manifold.

Camshaft Bearing Service

Slightly scored camshaft bearings will be satisfactory if the surfaces of camshaft journals are polished and bearings are cleaned up to remove burrs, and the fit of shaft in bearings is free and within the clearance limits of .0015" to .004"

Should the bearing be gauged beyond repair, the bearing will have to be replaced.

To install precision replacement cam bearing, special Tool J-27408 is required. To remove and install replacement bearing proceed as follows:

Bearing Removal

Care must be exercised during bearing removal and installation, not to damage bearings that are not being replaced.

1. Remove camshaft and crankshaft.

2. Assemble puller screw to required length.

3. Select proper size expanding collet and back-up nut.

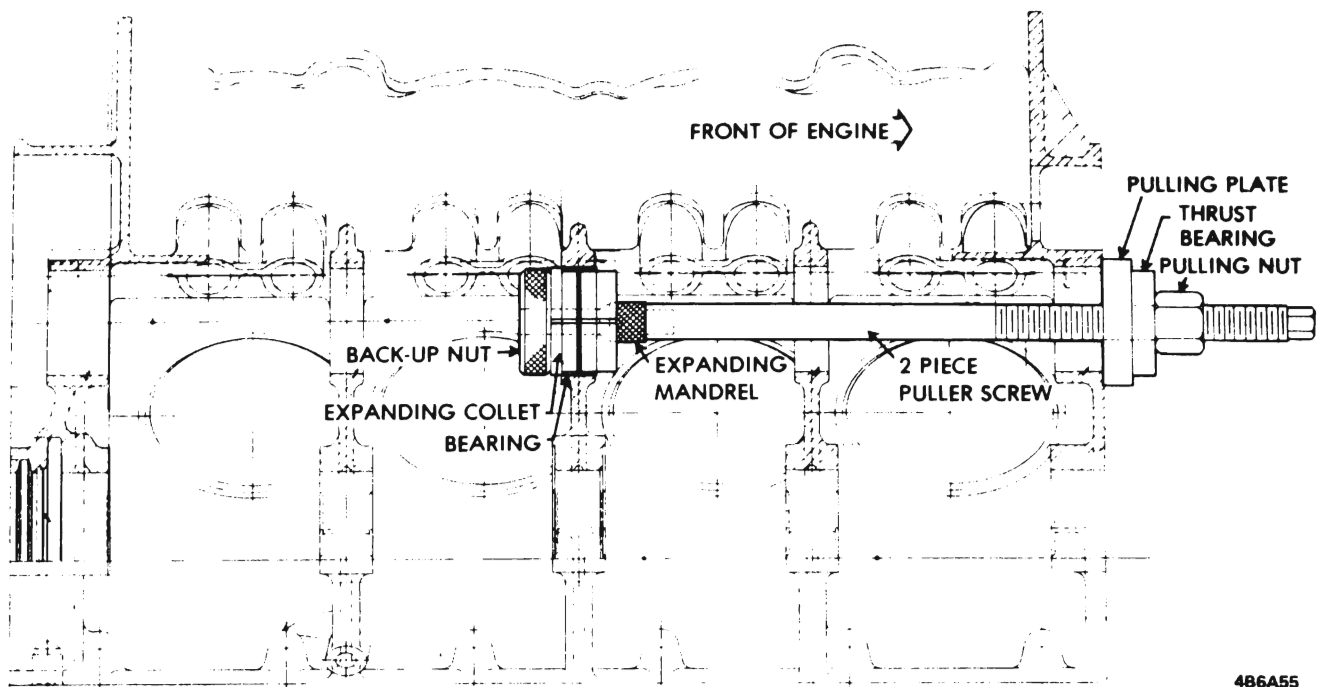

486A55

Figure 6A-101 - Removing and Installing Camshaft Bearings

4. Install expanding collet on expanding mandrel. Install back-up nut.

5. Insert this assembly into camshaft bearing to be removed. Tighten back-up nut to expand collet to fit I.D. of bearing.

6. Thread end of puller screw assembly into end of expanding mandrel and collet assembly.

7. Install pulling plate, thrust bearing, and pulling nut on threaded end of puller screw.

8. Bearing can then be removed by turning pulling nut. See Figure 6A-101.

Make certain to grip the 5/8" hex end of the puller screw with a wrench to keep it from rotating when the pulling nut is turned. Failure to do this will result in the "locking up" of all threads in the pulling assembly and possible over expansion of the collet.

9. Repeat the above procedure to remove any other bearings, except the front bearing, which may be pulled from the rear of the engine.

When removing rear cam bearing, it is necessary to remove welch plug at the back of cam bore. However, if only the front bearing is being replaced, it is not necessary to remove the engine or welch plug. The front bearing can be removed by using a spacer between the pulling plate and the cylinder block.

Bearing Installation

1. Assemble puller screw to required length.

2. Select proper size expanding collet and back-up nut.

3. Install expanding collet on expanding mandrel.

4. Install back-up nut.

5. Place new camshaft bearing on collet and GENTLY hand tighten back-up nut to expand collet to fit bearing. Do not over tighten back-up nut. A loose sliding fit between collet and bearing surface is adequate. This will provide just enough clearance to allow for the "collapse" which will occur when the new bearing is pulled into the engine block.

6. Slide mandrel assembly and bearing into bearing bore as far as it will go without force.

7. Thread end of puller screw onto the end of the mandrel.

Make certain to align oil holes in bearing and block properly. One of the collet separation lines may be used as a reference point.

8. Install pulling plate, thrust bearing and pulling nut on threaded end of puller screw.

9. Install bearing in the same manner as described in Steps 8 and 9 under "Bearing Removal."

When installing rear cam bearing, install new welch plug at back of cam bore. Coat O.D. of plug with non-hardening sealer before installation.

REMOVAL AND INSPECTION OF OIL PUMP COVER AND GEARS

Removal

1. Remove oil filter.
2. Remove screws attaching oil pump cover assembly to timing chain cover. Remove cover assembly and slide out oil pump gears.
3. Wash off gears and inspect for wear, scoring, etc. Replace any gears not found serviceable.
4. Remove the oil pressure relief valve cap, spring and valve. See Figure 6A-102. Oil filter by-pass valve and spring are staked in place and should not be removed.

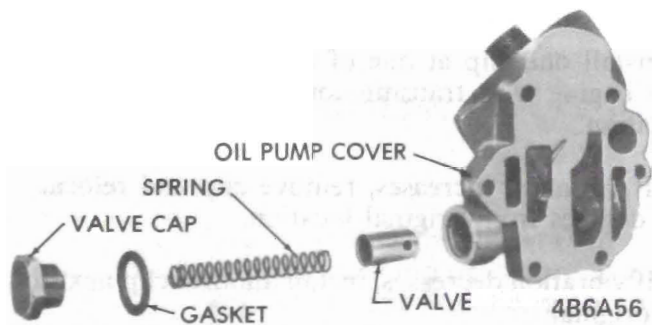

Figure 6A-102 - Oil Pump Cover and Pressure-Relief Valve

5. Wash the parts thoroughly and inspect the relief valve for wear or scoring. Check the relief valve spring to see that it is not worn on its side or collapsed. Replace any relief valve spring that is questionable.
6. Check the relief valve in its bore in the cover. The valve should have no more clearance than an easy slip fit. If any perceptible side shake can be felt the valve and/or cover should be replaced.
7. Check filter by-pass valve for cracks, nicks, or warping. The valve should be flat and free of nicks or scratches.

Installation

1. Lubricate and install pressure relief valve and spring in bore of oil pump cover. See Figure 6A-102. Install cap and gasket. Torque cap to 35 lb. ft. with a reliable torque wrench. Do not over-tighten.

2. Install oil pump gears and shaft in oil pump body section of timing chain cover to check gear end clearance.

3. Place a straight edge over the gears and measure the clearance between the straight edge and the gasket surface. See Figure 6A-103. Clearance should be between .0023" and .0058". If clearance is less than .0018" check timing chain cover gear pocket for evidence of wear.

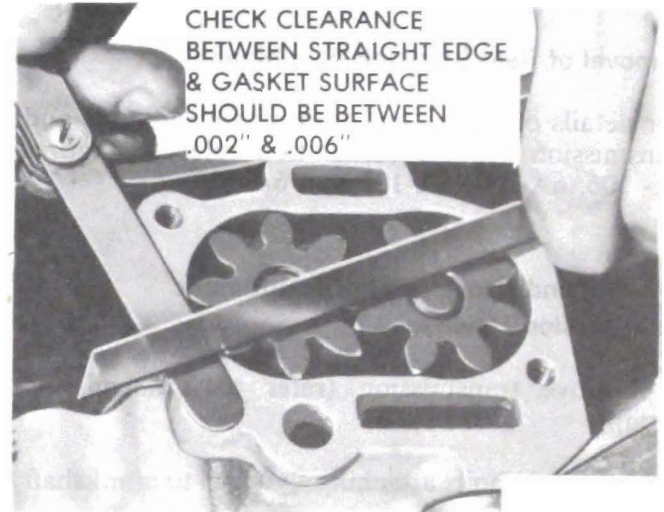

Figure 6A-103 - Checking Oil Pump End Clearance

4. If gear end clearance is satisfactory, remove gears and pack gear pocket full of petroleum jelly. Do not use chassis lube.
5. Reinstall gears so petroleum jelly is forced into every cavity of the gear pocket and between the teeth of the gears. Place *new* gasket in position. This step is very important. Unless the pump is packed with petroleum jelly it may not prime itself when the engine is started.
6. Install cover assembly screws. Tighten alternately and evenly. The torque specification is 10 lb. ft.
7. Install filter on nipple.

ENGINE MOUNTING, FLYWHEEL, AND ENGINE BALANCING

Removal of Front Mounts

1. Raise car and provide frame support at front of car.
2. Support weight of engine at forward edge of oil pan.
3. Remove mount to engine block bolts. Raise engine slightly and remove mount to mount bracket bolt and nut. Remove mount.

Installation of Front Mount

1. Install mount to engine block bolts and torque to 70 lb. ft.
2. Lower engine so mounts rest on frame cross member in normal manner. Install mount to bracket bolt and torque to 55 lb. ft.
3. Remove frame support and lower car.

Removal of Rear (transmission) Mount

For details of engine and transmission mounts and transmission support installation refer to Figures 6A-106, 6A-107, 6A-108 and 6A-109.

Removal and Replacement of Automatic Transmission Flywheel

1. Remove transmission (refer to Transmission Group).
2. Remove six bolts attaching flywheel to crankshaft flange.
3. Inspect flywheel; if cracked, replace flywheel.
4. Inspect crankshaft flange and flywheel for burrs. Remove any burrs with a mill file.
5. Install flywheel. Bolt holes are unevenly spaced so all flywheel bolts can be installed with flywheel in correct position. Install bolts and torque evenly to 60 lb. ft.
6. Mount dial indicator on engine block and check flywheel run-out at three attaching bosses. Run-out should not exceed .015". The crankshaft end play must be held in one direction during this check.
7. If run-out exceeds .015", attempt to correct by tapping high side with mallet. If this does not correct, remove flywheel and check for burrs between flywheel and crankshaft mounting flange.

Automatic Transmission Flywheel Balance

Clips are available from the Parts Department that will serve as balance weights for automatic transmission flywheels. These clips are secured by their clamping pressure to the flywheel. See Figure 6A-104 for clip installation locations.

If a flywheel is found to be out of balance, it can be corrected in the following manner.

1. Remove lower flywheel housing. Mark the flywheel at four locations, 90 degrees apart.

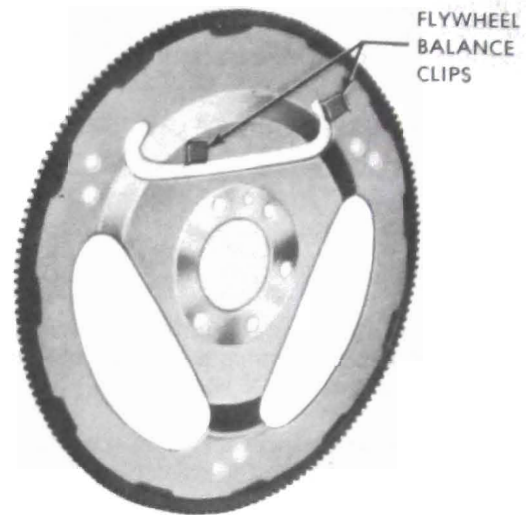

486A58

Figure 6A-104 - Automatic Transmission Flywheel Balance Clip Location (350 cu.in. Shown)

2. Install one clip at one of the marked locations. Run engine with transmission in neutral and note vibration.

(a) If vibration increases, remove clip and relocate 180 degrees from original location.

(b) If vibration decreases, install another clip next to the original.

(c) If no change is noted, move clip 90 degrees and recheck.

3. Continue this procedure until a reduction in vibration is noted. Fine adjustments can be made by moving the clips, by small increments, to different locations. Be certain that the tangs on the clip are set in the flywheel. Otherwise, the clip(s) may shift when the flywheel is turned at high speeds.

USE CHISEL TO UPSET SMALL AMOUNT OF MATERIAL THIS WILL PROVIDE A PRESS FIT

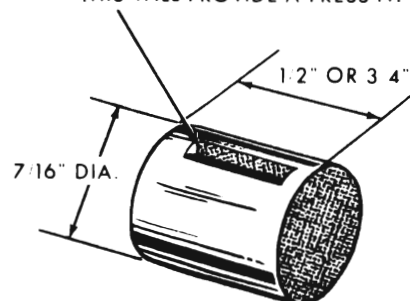

486A59

Figure 6A-105 - Harmonic Balancer - Balance Weight Details

Harmonic Balancer

If the harmonic balancer is suspected of being a cause of vibration, it can be checked and/or balanced by following the outline below:

- a. Using a tachometer, determine the engine speed at which the greatest amount of vibration occurs.
- b. Place an amount of body putty or similar material on the inside surface of the fan driving pulley. Run engine at critical speed and note vibration.
- c. Repeat Step a above using varying amounts of putty at different locations until the vibration is diminished to a minimum.
- d. When point of minimum vibration is found, mark the nearest hole drilled in the balancer at that point.
- e. Cut a piece of 7/16" iron rod approximately 1/2" long. Use a chisel, upset a small amount of material on the side of the piece of rod. See Figure 6A-105.
- f. Install iron rod into hole marked in Step 4.
- g. Additional weight should be added (if necessary) in adjoining holes.

SPECIFICATIONS**BOLT TORQUE SPECIFICATIONS**

Use a reliable torque wrench to obtain the figures listed below. This will prevent straining or distorting the parts, as well as preventing thread damage. These specifications are for clean and lightly-lubricated threads only. Dry or dirty threads produce friction which prevents accurate measurements of the actual torque. It is important that these specifications be strictly observed. Overtightening can damage threads. This will prevent attainment of the proper torque and will require replacement of the damaged part.

Area	Torque Lb. Ft.
Spark Plugs	15
Crankshaft Bearing Caps to Cylinder Block	115
Connecting Rods	350 With Cap Screw Fasteners (40) 455 (45)
Cylinder Head to Cylinder Block	350 (80) 455 (100)
Harmonic Balancer to Crankshaft	350 (140 Min.) 455 (200 Min.)
Fan Driving Pulley to Harmonic Balancer	23
Flywheel to Crankshaft (Auto. and Manual)	60
Oil Pan to Cylinder Block	14
Oil Pan Drain Plug	30
Oil Pump Cover to Timing Chain Cover	10
Oil Pump Pressure Regulator Retainer	35
Oil Screen Housing to Cylinder Block	8

Oil Pan Baffle to Cylinder Block	350 (11) 455 (8)
Oil Gallery Plugs	25
Oil Pressure Switch to Cylinder Block	23
Filter Assembly to Pump Cover	13
Timing Chain Cover to Block	29
Water Pump Cover to Timing Chain Cover	7
Fan Driven Pulley	20
Thermostat Housing to Intake Manifold	20
Automatic Choke Cover to Intake Manifold	8
Intake Manifold to Cylinder Head	45
Exhaust Manifold to Cylinder Head	28
Carburetor to Intake Manifold	15
Fuel Pump to Cylinder Block	20
Motor Mount to Cylinder Block	63
Fuel Pump Eccentric and Timing Chain Sprocket to Camshaft	350 (48) 455 (22)
Rocker Arm Cover to Cylinder Head	4
Rocker Arm Shaft to Cylinder Head	30
Delcotron Bracket to Cylinder Head	35
Delcotron Adjusting Bracket to Water Pump	22
Delcotron Mounting Bracket Through Delcotron to Cylinder Head at Pivot Location	35
Starting Motor to Block	35
Distributor Hold-Down Clamp	13
Lower Flywheel Housing Cover	4
Flywheel Housing to Cylinder Block	35

GENERAL SPECIFICATIONS**General**

	350-2	350-4	
Code Number Prefix	XC	XB	
Engine Type		90° V-8	
Bore and Stroke		3.800 x 3.850	
Piston Displacement		350 Cu.In.	
Carburetor Type	2BBL-Roch	4BBL-Roch	
Compression Ratio		8.5:1	
Gasoline Requirements		No Lead, Low Lead	
Octane Requirement - Motor		82	
Octane Requirement - Research		91	
Cylinder Numbers - Front to Rear			
Left Bank		1-3-5-7	
Cylinder Numbers - Front to Rear			
Right Bank		2-4-6-8	
Firing Order		1-8-4-3-6-5-7-2	
	455-4	455-4	455-4
Code Number Prefix	XF	(Stage I) XS	(GS Riv) XA
Engine Type		90° V-8	
Bore and Stroke		4.3125 x 3.900	
Piston Displacement		455 Cu.In.	
Carburetor Type	4BBL Roch	4BBL Roch	4BBL Roch
Compression Ratio		8.5:1	

Gasoline Requirements	No Lead, Low Lead
Octane Requirement - Motor	82
Octane Requirement - Research	91
Cylinder Numbers - Front to Rear Left Bank	1-3-5-7
Cylinder Numbers - Front to Rear Right Bank	2-4-6-8
Firing Order	1-8-4-3-6-5-7-2

Piston and Pin Specifications

Piston	
Material	Cast Aluminum Alloy
Type	Divorced Skirt
Finish	Cam Ground
Piston Pins	
Material	Extruded SAE-1018
Type	Pressed in Rod

Connecting Rods

Material	(350) Pearlite Malleable Cast Iron (455) SAE-1053 Steel Forged
Rod Bearing	Removable Steel Backed M/400 Aluminum

Ring Specifications

#1 Compression	Cast Iron Molybdenum Coated
#2 Compression	Cast Iron - Lubrited
Oil Control	(350) Uncoated Steel (455) SAE-1070 Steel (Chrome Plated)
Oil Ring Expander	Abutment Type
Ring Locations	Above Pin

Crankshaft Specifications

Material	Nodular Iron
Bearings	5 Replaceable Steel Backed
Bearing Material	#1,#2,#3 and #4 M/400 #5-M/100A Durex
Bearing Taking End Thrust	#3

Camshaft Specifications

Material	Cast Alloy Iron
Bearings	Steel Backed Babbitt
Number of Bearings	5
Drive	Chain
Number of Links	(350) 54 (455) 48
Crankshaft Sprocket	Sintered Iron
Camshaft Sprocket	Nylon-Coated Aluminum

Valve Specifications

350 Cu.In.

Intake Valve Material	SAE 1041 Steel - Aluminized Face and Chrome Flashed Stem
Exhaust Valve Material	21-2 Nickel-Plated Face and Chrome Flashed Stem
Valve Lifter Mechanism	Hydraulic
Valve Springs	Single Helical

455 Cu.In.

Intake Valve Material	Aluminized Face and Chrome Flash Stem SAE 1041 Steel
Exhaust Valve Material	21-2 Nickel-Plated Face and Chrome Flash Stem
Valve Lifter Mechanism	Hydraulic
Valve Springs	Single Helical

Lubrication System Specifications

Type of Lubrication

Main Bearings	Pressure
Connecting Rods	Pressure
Piston Pins	Splash
Camshaft Bearing	Pressure
Timing Chain	Drop From Front Cam Bearing
Cylinder Walls	Splash
Oil Pump Type	Gear Driven
Normal Oil Pressure	(350) 37 Lbs. at 2600 RPM (455) 40 Lbs. at 2400 RPM
Oil Pressure Sending Unit	Electrical
Oil Intake	Stationary
Oil Filter System	Full Flow
Filter Type	Throw-Away Element and Can
Crankcase Capacity - With Filter	5 Quarts
Crankcase Capacity - Less Filter	4 Quarts

ENGINE DIMENSIONS AND FITS

General

	350 Cu.In.	455 Cu.In.
Piston Clearance Limits*		
Top Land	.026-.034	.036-.044
Skirt Top	.0008-.0020	.0010-.0016
Skirt Bottom	.0013-.0035	.0020-.0036
Ring Groove Depth		
#1 - Compression Ring	.184-.194	.212-.222
#2 - Compression Ring	.186-.194	.215-.222
#3 - Oil Ring	.188-.196	.181-.222
Ring Width		
#1 - Compression Ring	.168-.178	.191-.201
#2 - Compression Ring	.168-.178	.191-.201
#3 - Oil Ring (3 Piece Ring)	.150-.156	.150-.156
Oil Ring (2 Piece Ring)	.135-.142	.135-.142
Ring Gap		
#1 - Compression Ring	.010-.020	.013-.023
#2 - Compression Ring	.010-.020	.013-.023
#3 - Oil Ring	.015-.035	.015-.035
Piston Pin Length	3.060	3.520
Diameter of Pin	.9391-.9394	.9991-.9994
Clearance		
In Piston (Selected)	.0004-.0007	.0004-.0007
Press Fit in Rod	.0007-.0017	.0006-.00016
Direction and Amount Offset in Piston	.040 Major Thrust Side	.060 Major Thrust Side

*All measurements in inches, unless otherwise specified.

Connecting Rod Specifications

	350 Cu.In.	455 Cu.In.
Bearing Length737	.820
Bearing Clearance (Limits)0002-.0023	.0002-.0023
End Play - Total for Both Rods006-.020	.005-.019

Crankshaft Specifications

	350 Cu.In.	455 Cu.In.
End Play at Thrust Bearing003-.009	.003-.009
Main Bearing Journal Diameter.....	3.0000	3.2500
Crankpin Journal Diameter	2.0000	2.249-2.250
Main Bearing Overall Length		
#1864	.865
#2864	.865
#3	1.057	1.057
#4864	.865
#5864	1.143
Main Bearing to Journal Clearance0004-.0015	.0007-.0018

Camshaft Specifications

Bearing Journal Diameter	
#1	1.785-1.786
#2	1.785-1.786
#3	1.785-1.786
#4	1.785-1.786
#5	1.785-1.786
Journal Clearance in Bearings0005-.0025 (#1) .0005-.0035 (#2,#3,#4, and #5)

Valve System Specifications

350 Cu.In.	
Rocker Arm Ratio	1.55:1
Valve Lifter Diameter8420-.8427
Valve Lifter Clearance in Crankcase0008-.0025
Valve Lifter Leakdown Rate	12 to 60 Sec. in Test Fixture
Intake Valve	
Overall Length	5.024-4.994
Head Diameter	1.880-1.870
Seat Angle	45°
Stem Diameter3730 - .3720
Clearance in Guide0015-.0035
Valve Spring	
Valve Closed - Lbs. at Length	75 ± 5# at 1.727
Valve Open - Lbs. at Length	180 ± 7# at 1.340
Exhaust Valve	
Overall Length	5.044-5.014
Head Diameter	1.505-1.495
Seat Angle	45°
Stem Diameter3723 Min. and .3730 Max.
Clearance in Guide0015-.0032
Valve Spring	
Valve Closed - Lbs. at Length	75 ± 5# at 1.727
Valve Open - Lbs. at Length	180 ± 7# at 1.340

455 Cu.In.

Rocker Arm Ratio	1.60:1
Valve Lifter Diameter8427-.8420
Valve Lifter Clearance in Crankcase0008-.0025
Valve Lifter Leakdown Rate	12 to 60 Sec. in Test Fixture
Intake Valve	
Head Diameter	2.005-1.995
Seat Angle	45°
Stem Diameter3730 - .3720
Clearance in Guide0015-.0035
Valve Spring	
Valve Closed - Lbs. at Length	72 ± 5# at 1.890
Valve Open - Lbs. at Length	177 ± 7# at 1.450
Exhaust Valve	
Head Diameter	1.625
Seat Angle	45°
Stem Diameter3723 Min. and .3730 Max.
Clearance in Guide0015 - .0032
Valve Spring	
Valve Closed - Lbs. at Length	72 ± 5# at 1.890
Valve Open - Lbs. at Length	177 ± 7# at 1.450

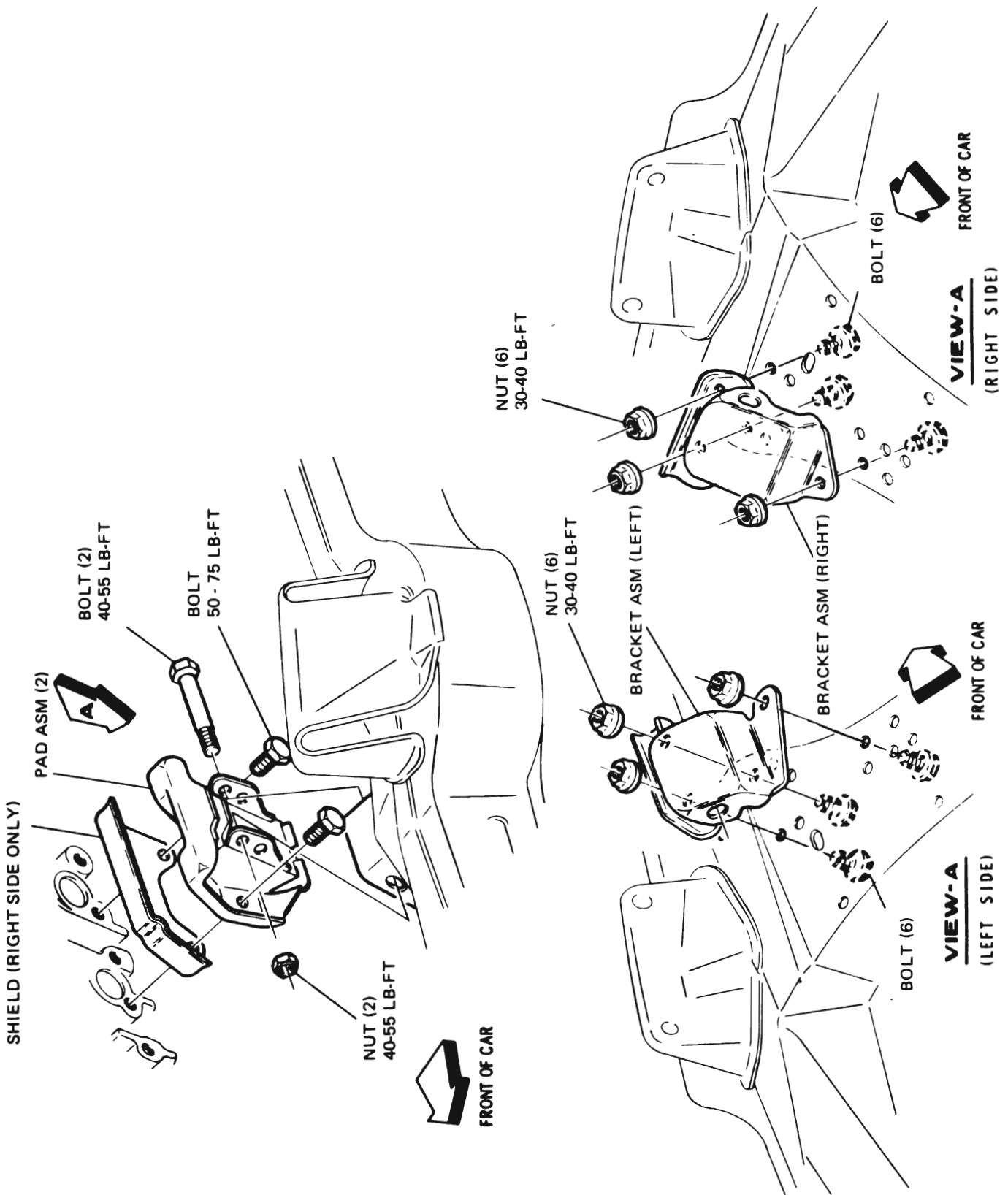

4B6A60

Figure 6A-106 Engine Mounting 455 B-C-E Series

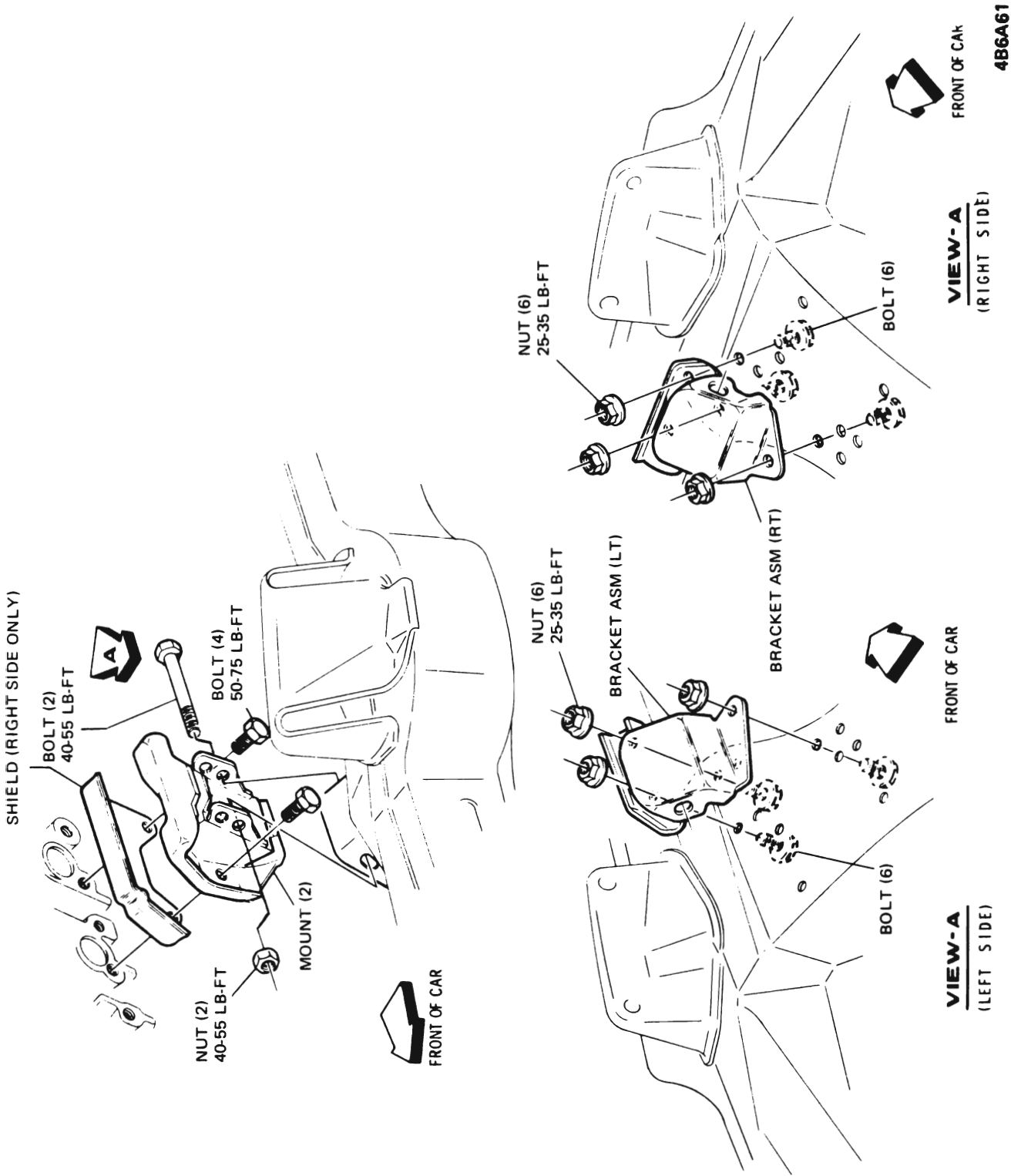

Figure 6A-107 Engine Mounting 455 "A" Series

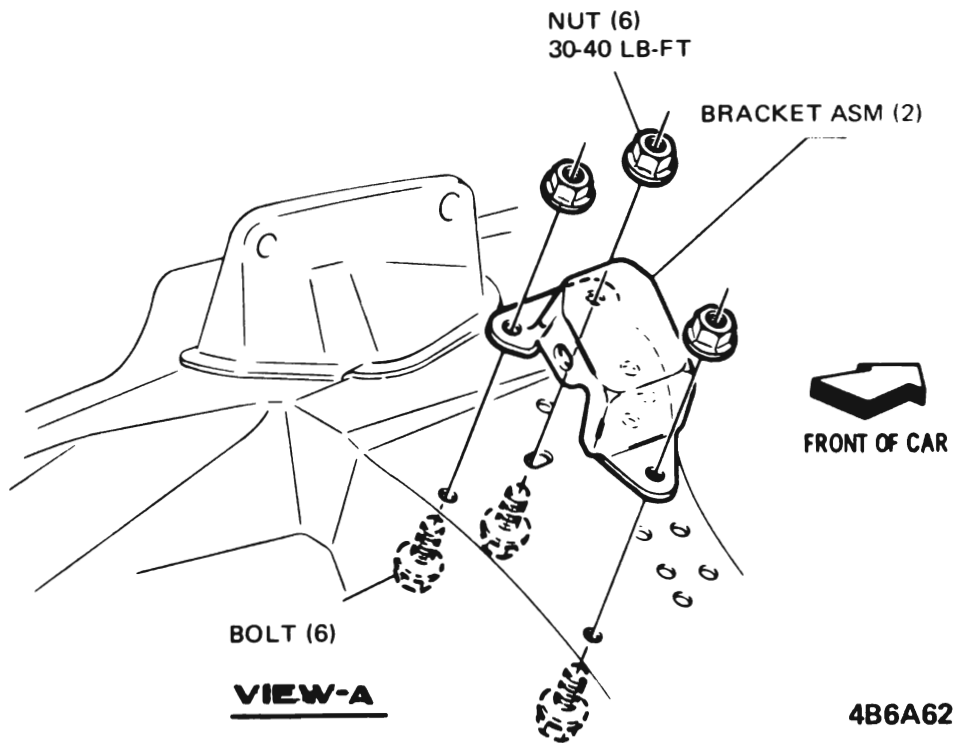
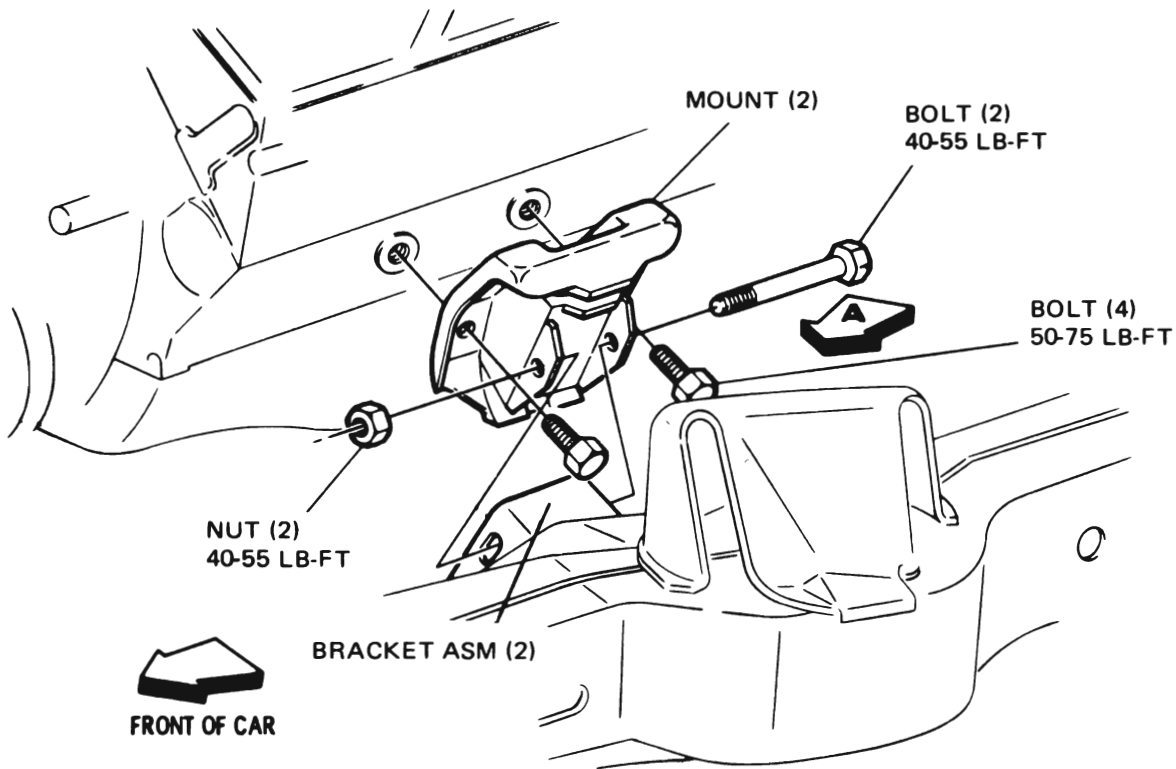

Figure 6A-108 Engine Mounting 350 "B" Series

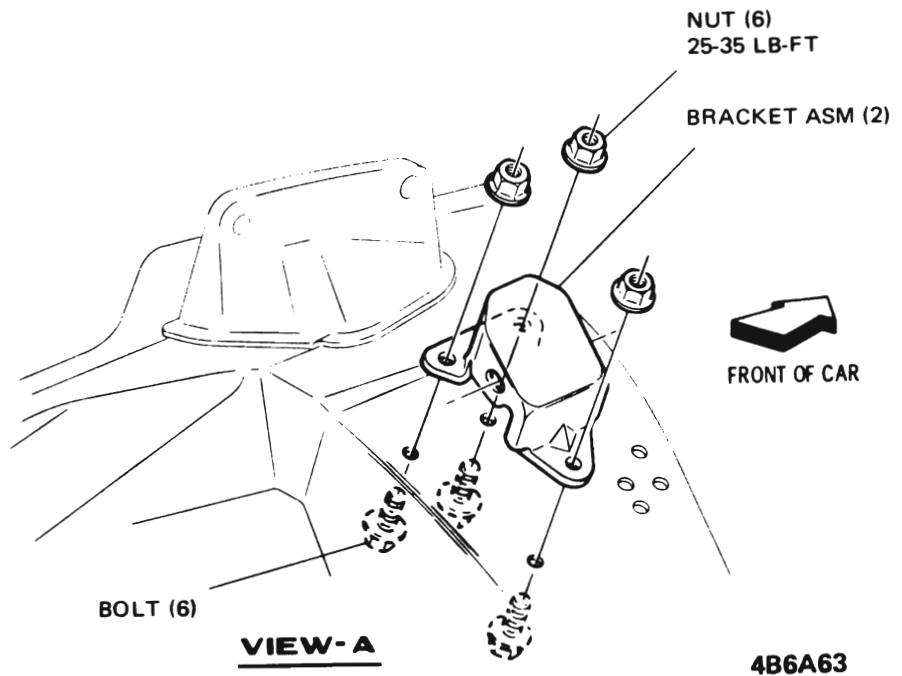
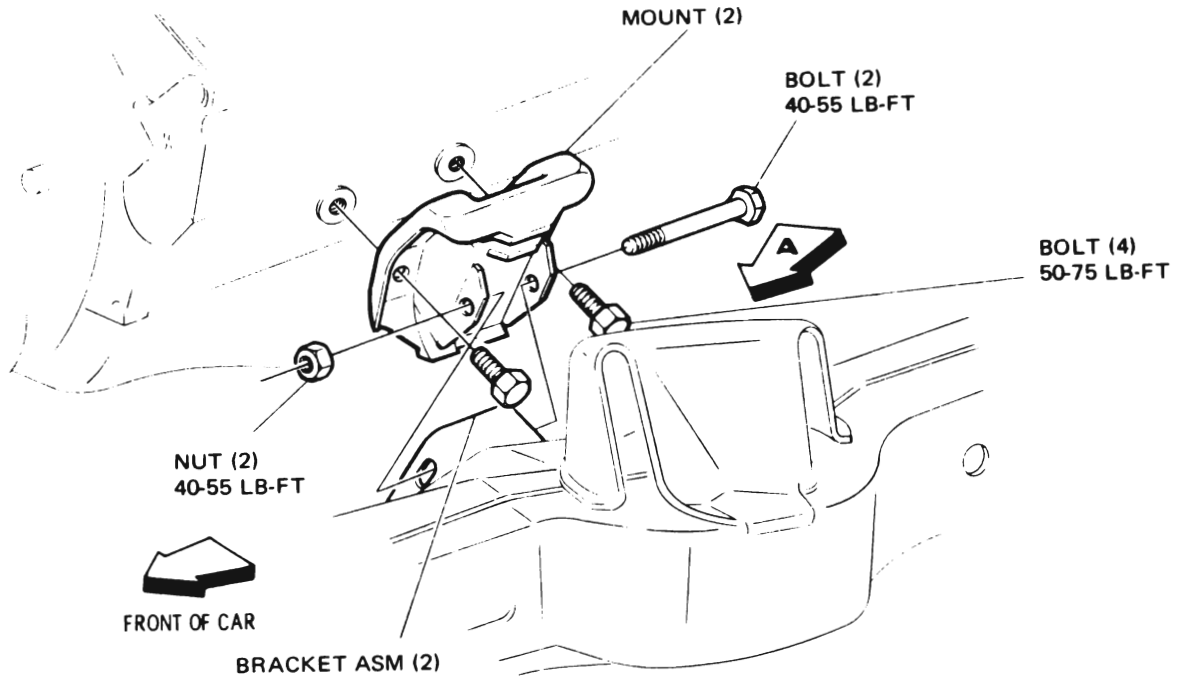
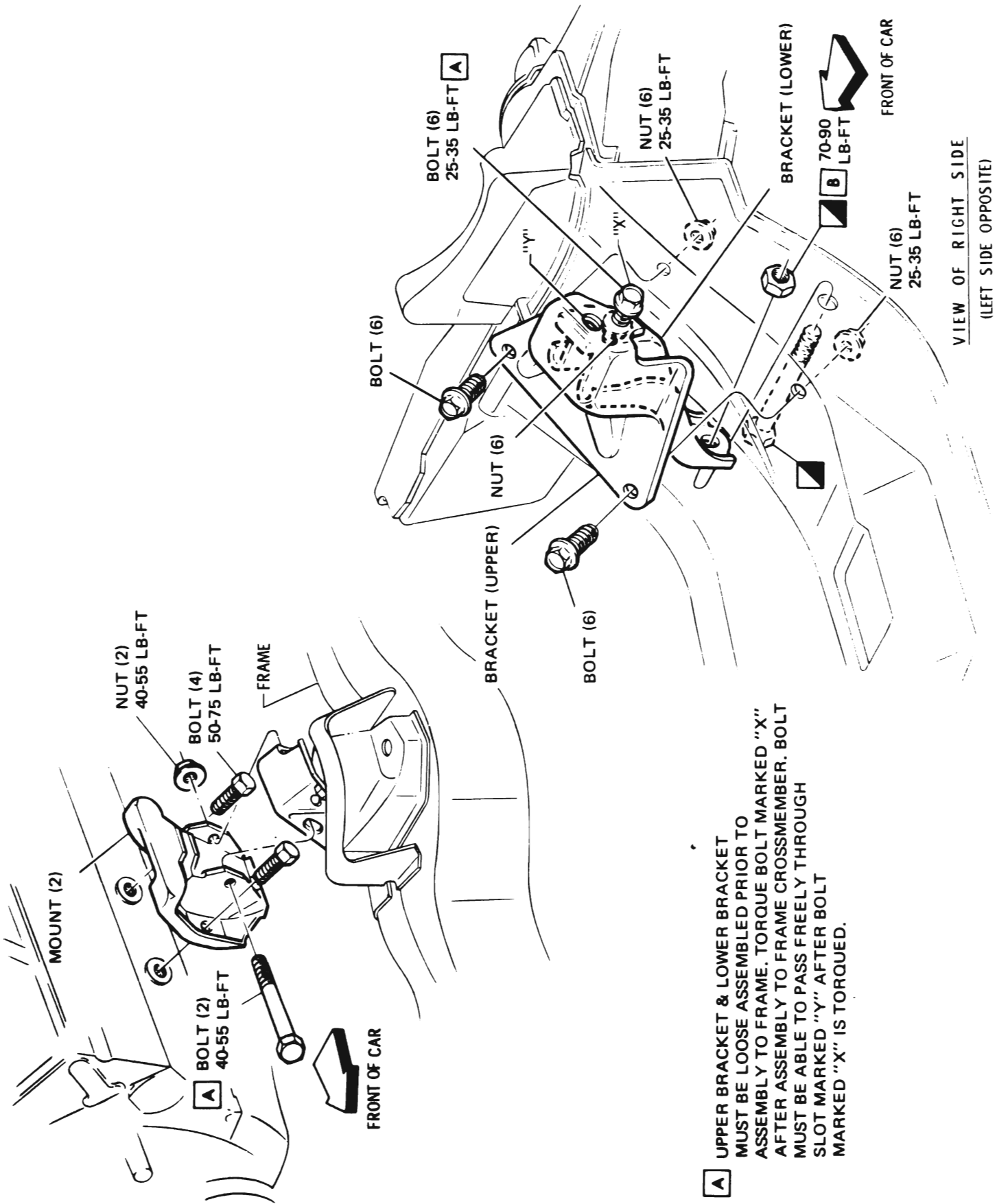

Figure 6A-109 Engine Mounting 350 "A" Series



486A64

Figure 6A-110 Engine Mounting 340 "X" Series

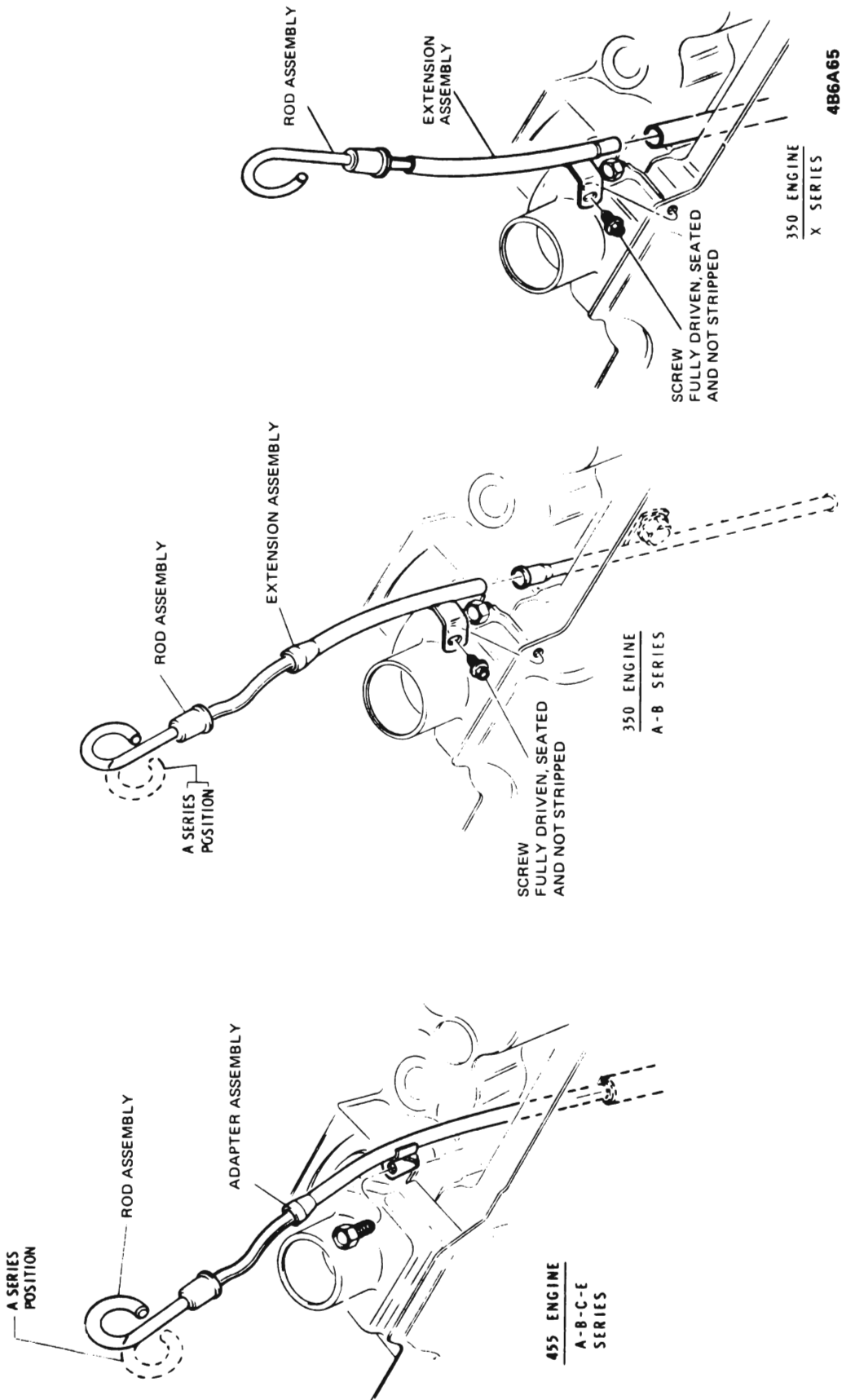
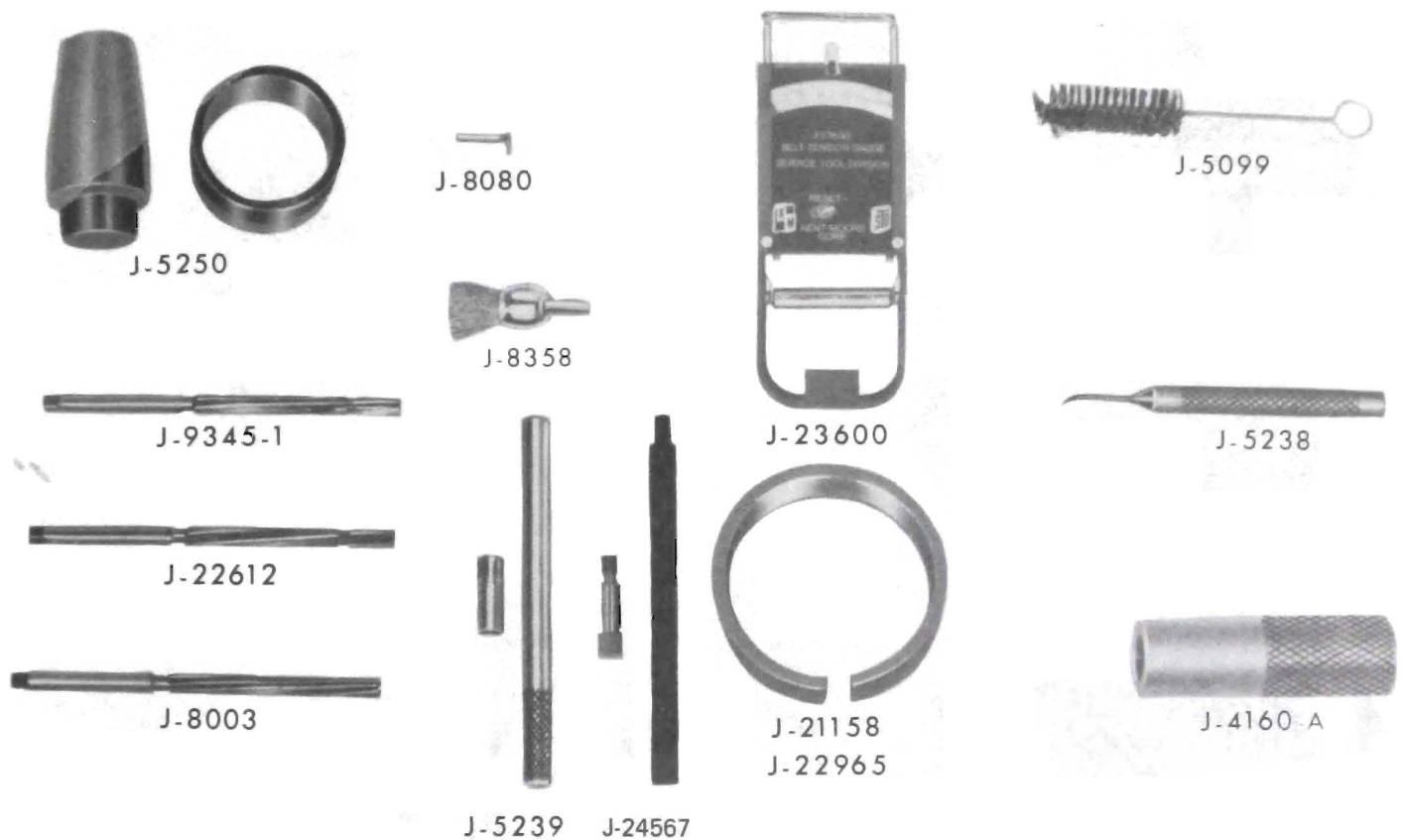

Figure 6A-111 Oil Gage Rod Position



J-24567	CONNECTING ROD GUIDE SET FOR CAP SCREW RODS
J-4160-A	HYDRAULIC VALVE LIFTER PLUNGER REMOVER
J-5099	HYDRAULIC VALVE LIFTER BODY CLEANING BRUSH
J-5238	HYDRAULIC VALVE LIFTER PLUNGER RETAINER REMOVER & INSTALLER
J-5250	TIMING CHAIN COVER OIL SEAL INSTALLER
J-22612	VALVE GUIDE REAMER .006 OVERSIZE
J-23600	BELT TENSION GAUGE
J-8080	MAIN BEARING SHELL REMOVER
J-8358	CARBON REMOVING BRUSH
J-8003	VALVE GUIDE REAMER 11/32"
J-5239	CONNECTING ROD BOLT GUIDE SET
J-21158	PISTON RING COMPRESSOR (455 CU. IN.)
J-22965	PISTON RING COMPRESSOR (350 CU. IN.)
J-9345-1	VALVE GUIDE REAMER

4B6A66

Figure 6A-112 Special Tools

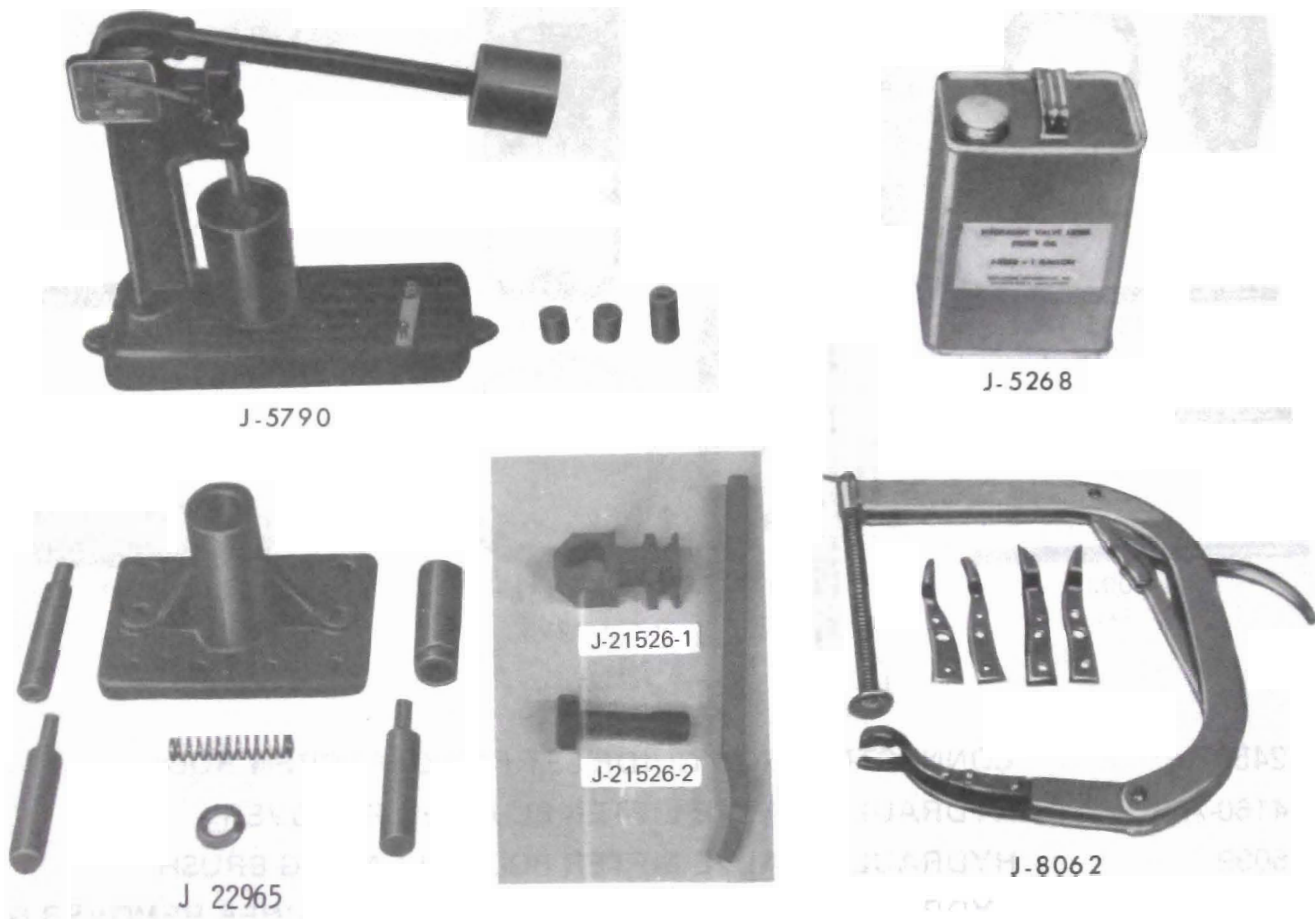

- J-5268 HYDRAULIC VALVE LIFTER TESTER OIL - ONE GALLON
- J-5790 HYDRAULIC VALVE LIFTER LEAKDOWN TESTER
- J-6047 PISTON PIN ASSEMBLY TOOL SET
- J-8062 VALVE SPRING COMPRESSOR
- J-21526-1 ROPE SEAL REPAIR GUIDE TOOL
- J-21526-2 ROPE SEAL REPAIR PACKING

4B6A67

Figure 6A-113 Special Tools

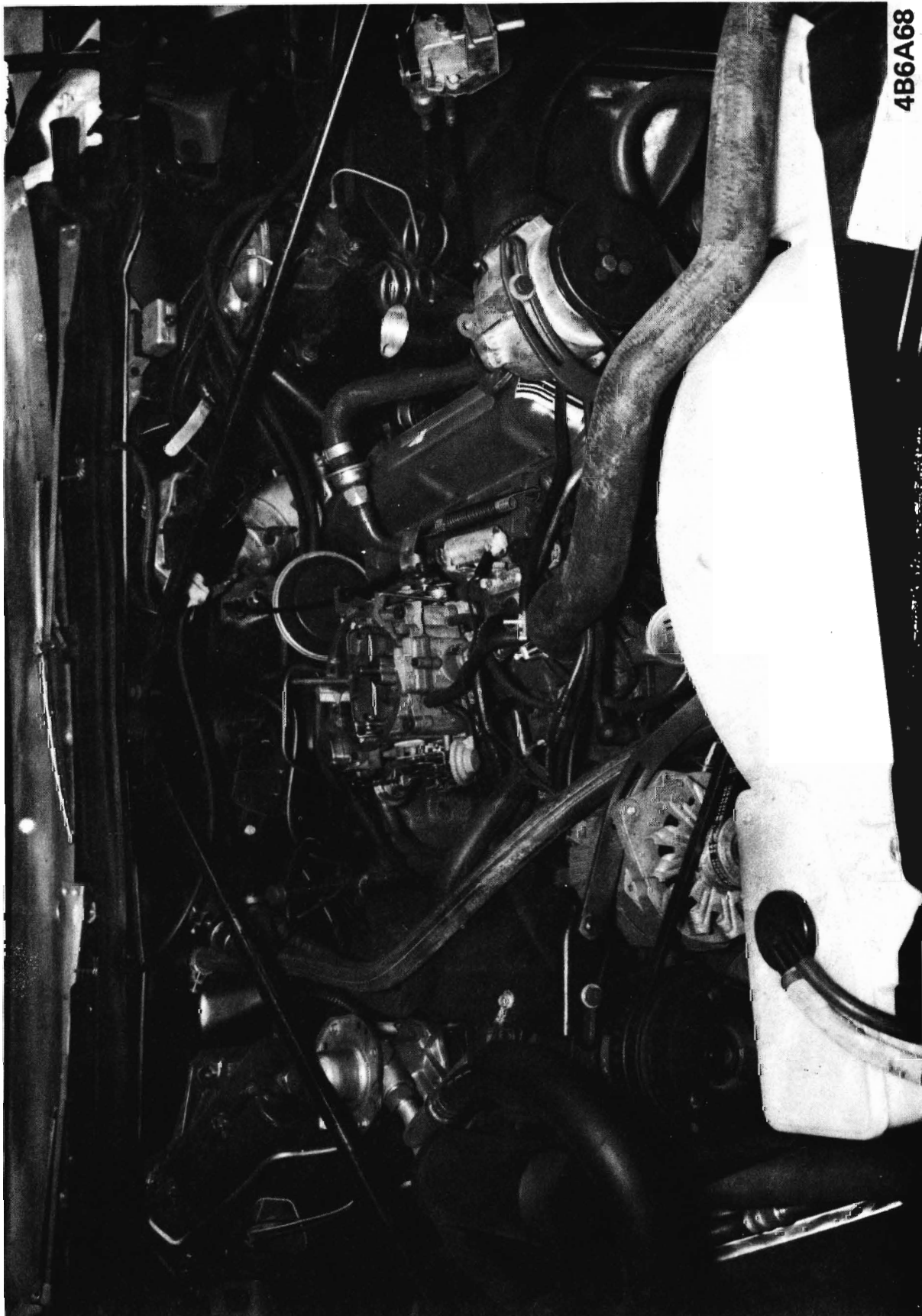

Figure 6A-114 Engine Compartment 350 Cu. In. Engine (Typical)



Figure 6A-115 Engine Compartment 455 Cu. In. Engine (Typical)