

POWER BRAKE UNITS

CONTENTS

Subject	Page No.
DESCRIPTION AND OPERATION:	
Description of Power Brake Units	5A- 2
DIAGNOSIS:	
Power Brake Unit Trouble Diagnosis	5A- 3
MAINTENANCE AND ADJUSTMENTS: (Not Applicable)	
MAJOR REPAIR:	
Removal and Installation of Power Brake Units	5A- 4
Disassembly of Delco Moraine Tandem Power Brake Unit	5A- 5
Cleaning and Inspecting Delco Moraine Tandem Power Brake Unit	5A- 8
Reassembly of Delco Moraine Tandem Power Brake Unit	5A- 9
Gauging of Delco Moraine Tandem Power Brake Unit	5A-12
Disassembly of Bendix Tandem Power Brake Unit	5A-12
Cleaning and Inspecting Bendix Tandem Power Brake Unit	5A-15
Reassembly of Bendix Tandem Power Brake Unit ..	5A-15
Gauging of Bendix Tandem Power Brake Unit	5A-17
Disassembly of Delco Moraine Power Brake Unit	5A-17
Cleaning and Inspecting Delco Moraine Power Brake Unit	5A-21
Reassembly of Delco Moraine Power Brake Unit ..	5A-24
Gauging of Delco Moraine Power Brake Unit	5A-26
SPECIFICATIONS:	
Power Brake Unit Specifications	5A-26

DESCRIPTION AND OPERATION

DESCRIPTION OF POWER BRAKE UNITS

The power brake unit is a combined vacuum and hydraulic unit which utilizes engine intake manifold vacuum and atmospheric pressure to provide power-assisted application of vehicle brakes.

The unit requires a vacuum connection to the engine intake manifold (through a vacuum check valve) and a mechanical connection to the brake pedal. The unit

is self-contained with no external rods or levers exposed to dirt or moisture.

The vacuum power brake unit contains the power piston assembly, which houses the control valve and reaction mechanism, and the power piston return spring. The control valve is composed of an air valve (valve plunger), the floating control valve assembly, and the push rod. The reaction mechanism consists of a hydraulic piston reaction plate and a series of levers. An air filter, air silencer, and filter retainer are assembled around the valve operating rod filling the cavity inside the hub of the power piston. The

push rod or valve operating rod, which operates the air valve, projects out of the end of the power unit housing through a rubber dust guard. A vacuum

check valve assembly is mounted in the front shell of the housing assembly for connection to the vacuum source.

DIAGNOSIS

POWER BRAKE UNIT TROUBLE DIAGNOSIS

Testing

The same types of brake trouble are encountered with power brakes as with manual brakes. Before checking the power brake system for the source of trouble, refer to the Trouble Diagnosis Chart in the Rear Drum Brake Section. After these possible causes have been eliminated, check for the causes at outlined in the following charts:

Condition	Possible Cause	Correction
Hard Pedal	1. Broken or damaged hydraulic brake lines.	1. Inspect and replace as necessary.
	2. Vacuum failure.	2. Check for: Faulty vacuum check valve or grommet - replace. Collapsed or damaged vacuum hose - replace. Plugged or loose vacuum fitting - repair. Faulty air valve seal or support plate seal - replace. Damaged floating control valve - replace. Bad stud welds on front or rear housing or power head - replace, unless easily repaired.
	3. Defective diaphragm.	3. Replace
	4. Restricted air filter element.	4. Replace
	5. Worn or badly-distorted reaction disc (tandem diaphragm).	5. Replace reaction disc.
	6. Worn or distorted reaction plate or levers (single diaphragm).	6. Replace plate or levers.
	7. Cracked or broken power pistons or retainer.	7. Replace power pistons and piston rod retainer.

	8. Incorrect selective reaction piston (tandem diaphragm only).	8. Gauge reaction piston and replace with correct piston.
Grabby Brakes (Apparent Off-and-On Condition)	1. Broken or damaged hydraulic brake lines.	1. Inspect and replace as necessary.
	2. Insufficient fluid in master cylinder.	2. Fill reservoirs with approved brake fluid; check for leaks.
	3. Defective master cylinder seals.	3. Repair or replace as necessary.
	4. Cracked master cylinder casting.	4. Replace
	5. Leaks at front disc brake calipers or rear wheel cylinders in pipes or connections.	5. Inspect and repair as necessary.
	6. Air in hydraulic system.	6. Bleed system.
Brakes Fail to Release	1. Blocked passage in power piston.	1. Inspect and repair or replace as necessary.
	2. Air valve sticking shut.	2. Check for proper lubrication of air valve "O" ring.
	3. Broken piston return spring.	3. Replace
	4. Broken air valve spring.	4. Replace
	5. Tight pedal linkage.	5. Repair or replace as necessary.

MAJOR REPAIR

REMOVAL AND INSTALLATION OF POWER BRAKE UNITS

1. Remove two nuts holding master cylinder to power cylinder and position it away from power cylinder.

CAUTION: Do not disconnect hydraulic brake lines; be careful not to bend or kink lines.

2. Disconnect the vacuum hose from the vacuum check valve on the front housing of the power head. Plug vacuum hose to prevent dust and dirt from entering hose.

3. Disconnect the power brake push rod from the brake pedal.

4. Remove the four nuts from the mounting studs which hold the power brake to the cowl.

5. Carry the power brake to a clean work area and clean the exterior of the power brake prior to disassembly.

CAUTION: Fasteners in the following steps are important attaching parts in that they could affect the performance of vital components and systems and/or could result in major repair expense. It must be replaced with one of the same part number, or with an equivalent part, if replacement becomes necessary. Do not use a replacement part of

lesser quality or substitute design. Torque values must be used as specified during reassembly to assure proper retention of this part.

6. Mount power brake assembly to cowl.
7. Remove inboard locknut from front housing stud, attach metering valve mounting bracket, reassemble locknut on stud and torque to 25 foot pounds.
8. Connect power brake push rod to brake pedal.
9. Connect vacuum hose to vacuum check valve.
10. Connect master cylinder to power cylinder and torque nuts to 24 lb. ft.

DISASSEMBLY OF DELCO MORAINÉ TANDEM POWER BRAKE UNIT

Disassembly of Overall Unit

Scribe a line across front and rear housings to facilitate reassembly.

1. Mount Unlock Tool J-23456 in a vise. Position housing assembly on tool so that four studs fit in holes provided. See Figure 5A-4.

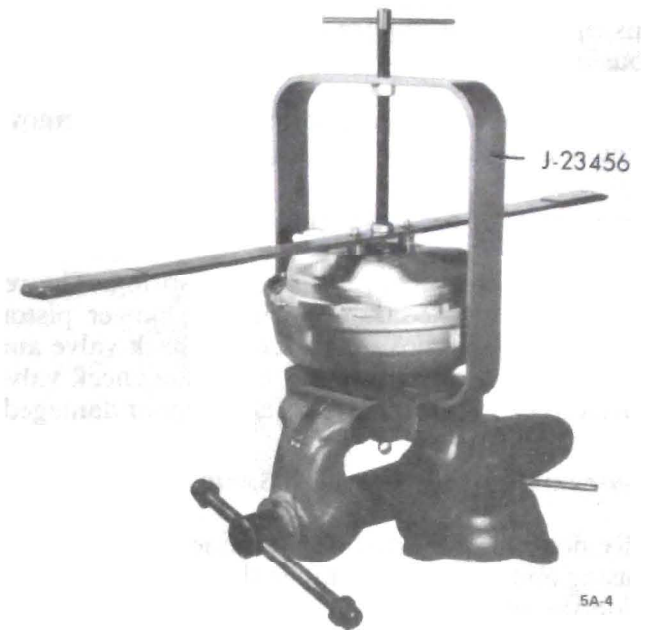

Figure 5A-4 Unlocking Front and Rear Housings

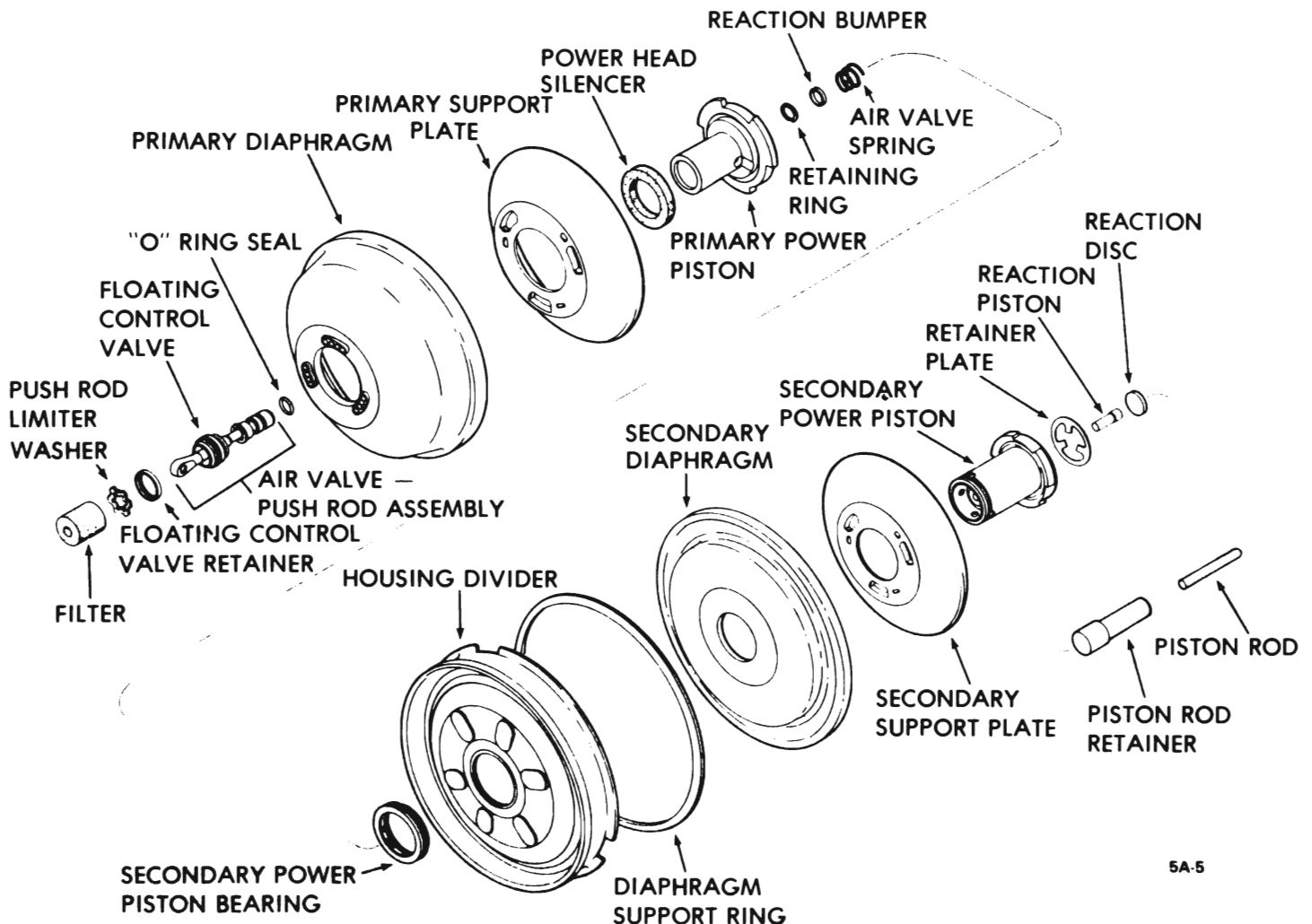

Figure 5A-5 Power Piston Group

2. Position handle over two studs with tubular projections downward. Rotate screw to apply downward pressure to handle, then rotate front housing counterclockwise to unlock housings. It is normal for this operation to require heavy pressure to unlock housings.

3. Rotate screw to release spring tension and remove front housing group.

Disassembly of Front Housing Group

1. Remove the power piston return spring. The retainer plate may come out with the power piston return spring. Remove the vacuum check valve and grommet from the front housing, if the check valve is defective or the grommet cracked, cut or damaged.

Disassembly of Rear Housing Group

1. Remove the boot and boot retainer from the rear housing and push rod. Remove the felt silencer from inside the boot.

2. Remove the power piston group from the rear housing and remove the primary power piston bearing from the center opening of the rear housing.

Disassembly of Power Piston Group

1. Lift the bead on the O.D. of the secondary diaphragm and remove the diaphragm support ring. See Figure 5A-5.

2. If not already disengaged, remove the retainer plate from the secondary piston. Remove the piston rod retainer and piston rod from the secondary piston.

NOTE: Due to an optional construction design on the primary and secondary power pistons, special tool J-23101 will have to be reworked, as shown in Figure 5A-6.

3. Mount double-ended tool J-23101 (with large diameter end up) in a vise. Position the secondary power piston so that the two radial slots in the piston fit over the ears (tang) of the tool. See Figure 5A-7.

4. Fold back primary diaphragm from the O.D. of the primary support plate. Grip the edge of the support plate and rotate counterclockwise to unscrew the primary power piston from the secondary power piston. Note: It is possible that the primary support plate will unlock from the primary piston before the primary piston unscrews from the secondary piston. If this happens, continue to turn the primary support plate counterclockwise. Tabs ("stops") on the primary support plate will temporarily lock the primary support plate to the primary power piston and per-

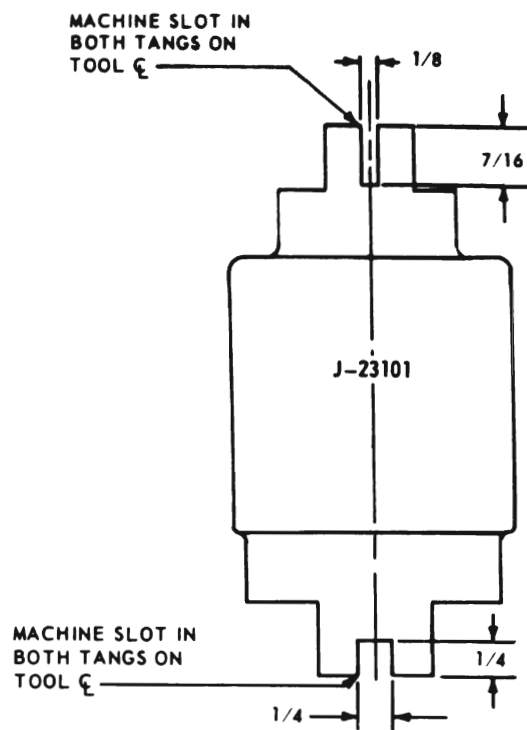

TOOL REWORK TO ACCOMMODATE
OPTIONAL POWER PISTON DESIGN

4B5A6

Figure 5A-6

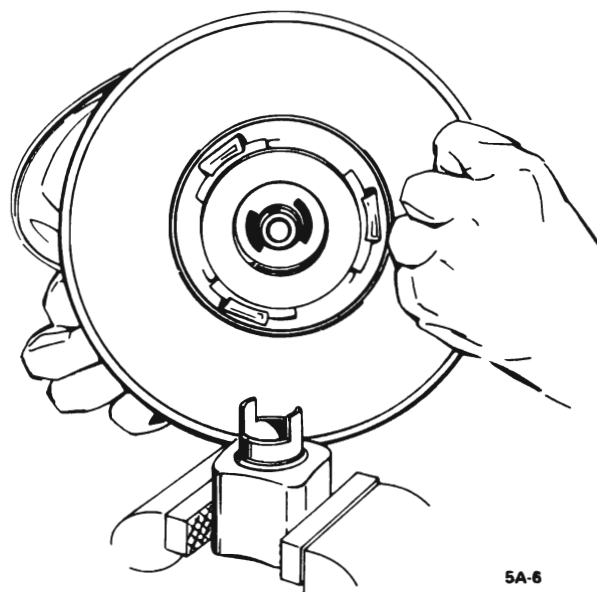

5A-6

Figure 5A-7 Positioning Secondary Power Piston In
Tool J-23101 (Large Dia. End Up) Mounted In Vise

mit continued counterclockwise rotation to unscrew the primary power piston from the secondary power piston. See Figure 5A-8.

5. Remove the housing divider from the secondary

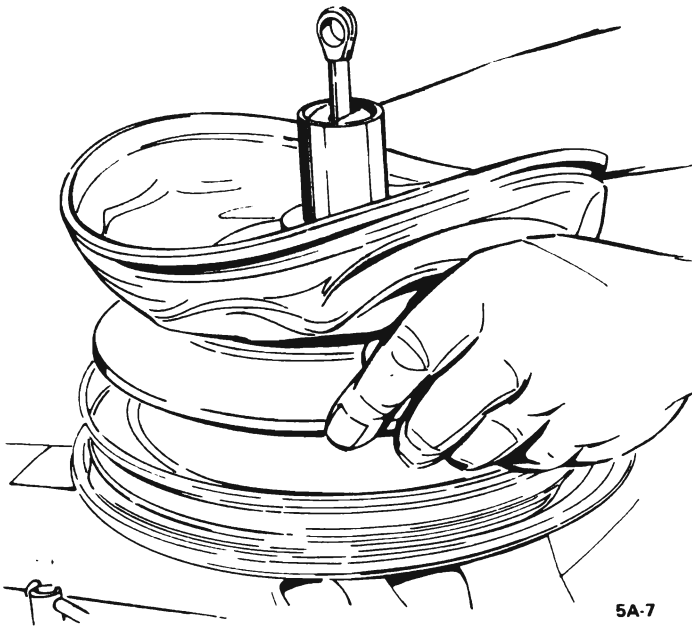

Figure 5A-8 Locking or Unlocking Primary and Secondary Power Pistons

power piston. Remove the secondary power piston bearing from the housing divider.

6. The secondary power piston should still be positioned on tool J-23101. Fold back secondary diaphragm from O.D. of secondary support plate. Grip the edges of the support plate and rotate clockwise to unlock the secondary support plate from the secondary power piston. See Figure 5A-9.

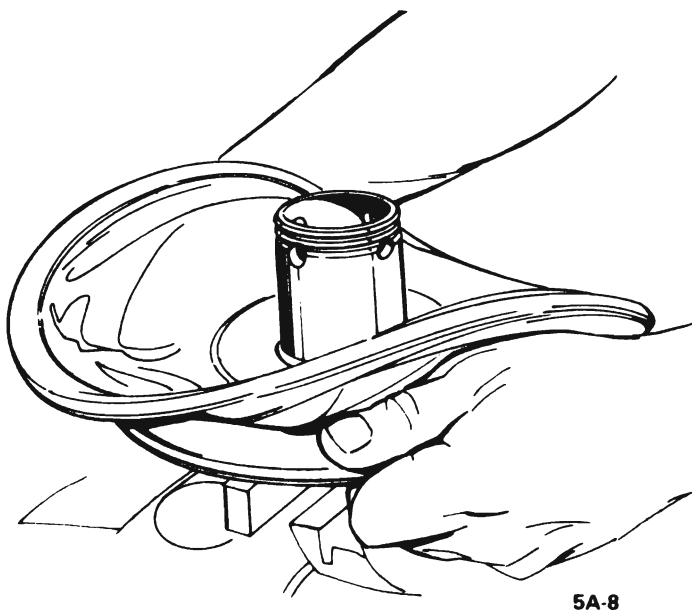

Figure 5A-9 Locking or Unlocking Secondary Support Plate and Secondary Power Piston

7. Remove the secondary diaphragm from the secondary support plate.

8. Remove the reaction piston and reaction disc from the center of the secondary power piston by pushing down on the end of the reaction piston with a small object, such as a pencil, wooden dowel, or metal rod. See Figure 5A-10.

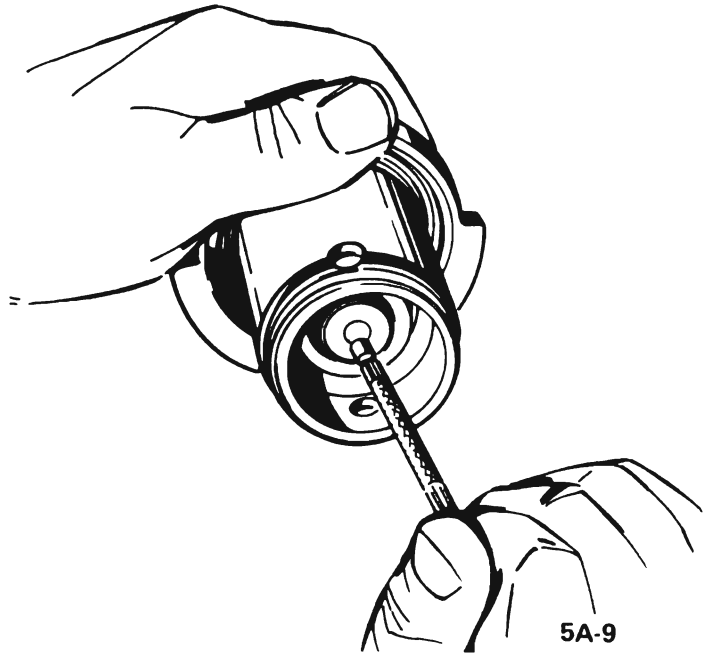

Figure 5A-10 Removing Reaction Piston and Reaction Disc From Secondary Power Piston

9. Remove the air valve spring from the end of the air valve (if it didn't come off during disassembly of the power piston).

10. Mount tool J-23101 in a vise (*with small diameter end up*). Position the primary power piston so

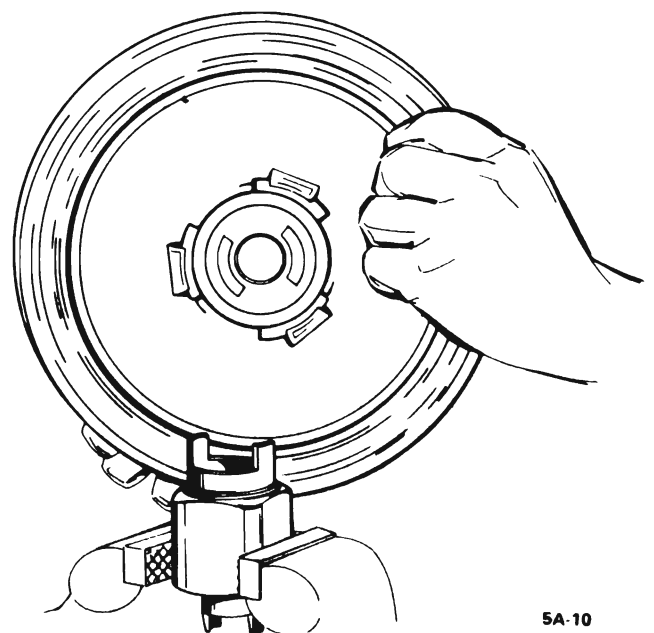

Figure 5A-11 Positioning Primary Power Piston In Tool J-23101 (Small Dia. End Up) Mounted In Vise

that the two radial slots in the piston fit over the ears (tangs) of the tool. See Figure 5A-11.

11. Fold back primary diaphragm from the support plate. Grip the edge of the support plate and rotate in a counterclockwise direction to unlock the primary support plate from the primary power piston. See Figure 5A-12.

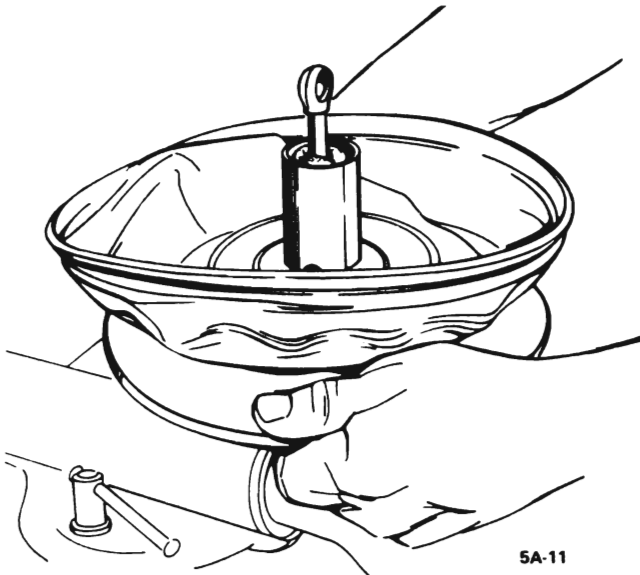

Figure 5A-12 Locking or Unlocking Primary Support Plate From Primary Power Piston

12. Remove the primary diaphragm from the primary support plate.

13. Remove the air filter and push rod limiter washer from the tubular section of the primary power piston.

14. Remove the power head silencer from the neck of the power piston tube.

15. Remove the rubber reaction bumper from the end of the air valve.

16. Using Truarc No. 2 pliers (J-4880), remove the retaining ring from the air valve. See Figure 5A-13.

17. Remove the air valve-push rod assembly from the tube end of the primary power piston. The following removal methods are recommended:

(a) Place the primary power piston in an arbor press, and press the air valve push rod assembly out the bottom of the power piston tube with a rod not exceeding 1/2" in diameter.

(b) An alternate method would be the use of a heavy, round shanked screwdriver. Insert screwdriver on both sides of the push rod, and pull the air valve push



Figure 5A-13 Removing Retaining Ring From Air Valve

rod assembly straight out. A considerable force will be required.

(c) Another method requires the use of Truarc No. 22 pliers. Approximately 5/8" from the pointed ends of the pliers, file or saw a small slot (approximately 1/32" - 1/16" wide and 1/10" deep) on each half of the pliers. Round off the pointed ends of the pliers. Slip the slots in the pliers into tangs on the control valve spring retainer. Grip the pliers and pull the air valve push rod assembly straight out.

18. Removal of the air valve push rod assembly will disassemble the control valve retainer.

19. Remove the "O" ring seal from the air valve.

20. Models using air valve push rod assemblies with a formed eye on the end of the push rod will be serviced using a complete assembly, since the floating control valve cannot be removed over the eye end of the push rod.

CLEANING AND INSPECTION OF DELCO MORAINÉ TANDEM POWER BRAKE UNIT

Cleaning

Use Declene or clean brake fluid to thoroughly clean all reusable brake parts. Immerse in the cleaning fluid and brush metal parts with hair brush to remove foreign matter. Blow out all passages, orifices and valve holes. Air dry and place cleaned parts on clean paper or lint free clean cloth. If slight rust is found inside either the front or rear half housing assemblies, polish clean with crocus cloth or fine

emery paper, washing clean afterwards. Dirt is the major cause of trouble and wear in service. Be sure to keep parts clean until re-assembly. Re-wash at re-assembly if there is any occasion to doubt cleanliness--such as parts dropped or left exposed for eight hours or longer.

CAUTION: *If there is any suspicion of contamination or any evidence of corrosion, completely flush the car hydraulic brake system. Failure to clean the hydraulic brake system can result in early repetition of trouble. Use of gasoline, kerosene, anti-freeze, alcohol or any other cleaner, with even a trace of mineral oil, will damage rubber parts.*

Inspecting Rubber Parts

Wipe fluid from the rubber parts and carefully inspect each rubber part for cuts, nicks, or other damage. These parts are the key to the control of fluid or air flow. If the unit is in for overhaul, or if there is any question as to the serviceability of rubber parts, **REPLACE** them!

Inspecting Metal Parts

BADLY DAMAGED ITEMS, OR THOSE WHICH WOULD TAKE EXTENSIVE WORK OR TIME TO REPAIR, SHOULD BE REPLACED. In case of doubt, install new parts. Do not rely on the brake unit being overhauled at an early or proper interval. New parts will provide more satisfactory service, even if the brake unit is allowed to go beyond the desired over haul period.

REASSEMBLY OF DELCO MORAINÉ TANDEM POWER BRAKE UNIT

General

1. Be careful during the rebuild procedure that no grease or mineral oil comes in contact with the rubber parts of the power brake unit.
2. Lubricate power head parts, as outlined below, with Delco Moraine power brake silicone lubricant. This lubricant is provided in the service repair kit.

Reassembly of Front Housing Group

1. If the grommet was removed for replacement, insert the new grommet in the front housing.
2. Press the vacuum check valve through the grommet.

Reassembly of Power Piston Group

1. Lubricate the I.D. and O.D. of the "O" ring seal with silicone lubricant and place on the air valve.
2. Wipe a thin film of silicone lubricant on the large and small O.D. of the floating control valve.
3. If the floating control valve needs replacement, it will be necessary to replace the complete air valve push rod assembly, since the floating control valve is a component part of this assembly and cannot be disassembled from the push rod.
4. Place the air valve end of the air valve push rod assembly into the tube of the primary power piston. Manually press the air valve push rod assembly so that the floating control valve bottoms on the tube section of the primary power piston. Installer tool J-23175 can be used to manually press the floating control valve to its seat.
5. Place the I.D. of the floating control valve retainer on the O.D. of floating control valve retainer installer J-23175. See Figure 5A-14. Place over the push rod so that the closed side of the retainer seats on the floating control valve. With Installer J-23175, manually press the retainer and floating control valve assembly to seat in the primary power piston tube. See Figure 5A-15.

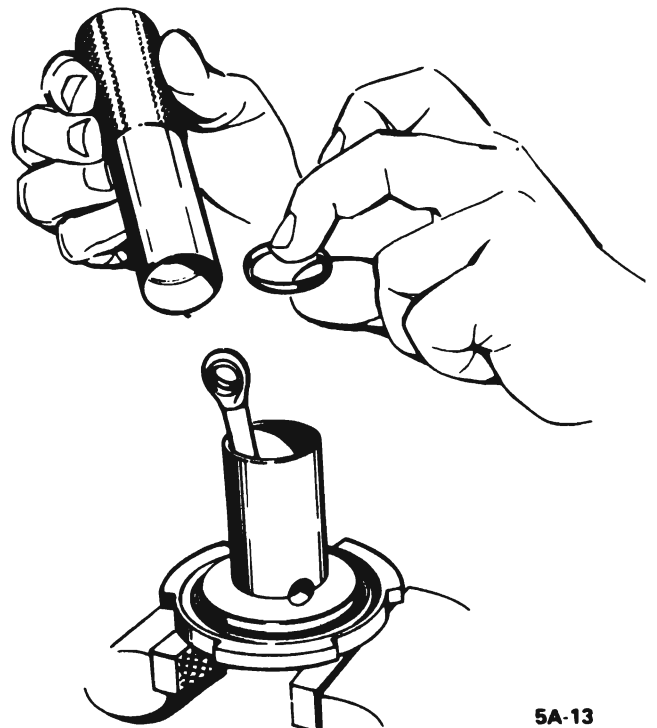

5A-13

Figure 5A-14 Installing Floating Control Valve Retainer With Installer J-23175

6. After the floating control valve is seated, place the push rod limiter washer over the push rod and position on the floating control valve.

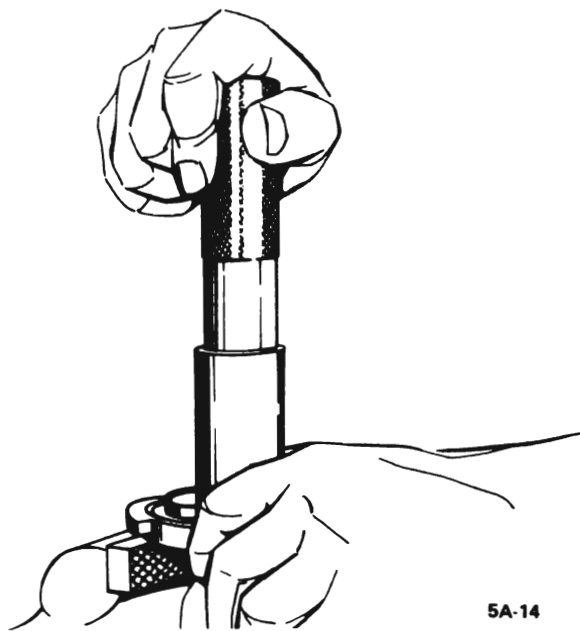

Figure 5A-15 Seating Floating Control Valve Assembly With Installer J-23175

7. The filter element can now be stretched over the push rod eye and pressed into the primary power piston tube.

8. Using Truarc No. 2 plier (J-4880), place the retaining ring into the groove in the air valve. See Figure 5A-13.

9. Position the rubber reaction bumper on the end of the air valve.

10. *Tolerances of those component parts affecting output of the tandem power brake are very critical. Always use the factory gauged power piston kit, containing both the primary and secondary power pistons with factory gauged reaction piston, when replacement of any of these parts is required.*

12. After determination of the correct reaction piston, apply a light film of silicone lubricant to the O.D. of the rubber reaction disc.

13. Place the rubber reaction disc in the large cavity of the secondary power piston and push the disc down to seat on the reaction piston.

14. Unlock the secondary power piston from the primary power piston.

15. Assemble the primary diaphragm to the primary support plate from the side of the support plate opposite the locking tangs. Press the raised flange on the I.D. of the diaphragm through the center hole of the support plate. Be sure that the edge of the support plate center hole fits into the groove in the raised flange of the diaphragm. Lubricate the diaphragm I.D. and the raised surface of the flange (that fits into a groove in the primary power piston) with a light coat of silicone lubricant.

16. Mount Tool J-23101 (small diameter end up) in a vise. Position the primary power piston so that the two radial slots in the piston fit over the ears (tang) of the tool. See Figure 5A-11.

17. Fold the primary diaphragm away from the O.D. of the primary support plate.

18. Holding the edges of the support plate, with the locking tangs down, place the primary support plate and diaphragm assembly over the tube of the primary power piston. The flange of the I.D. of the primary diaphragm will fit into a groove in the primary power piston.

19. Grip the edges of the primary support plate, press down, and rotate clockwise until the tabs on the primary power piston contact the stops on the support plate. See Figure 5A-12.

20. Place the power head silencer on the tube of the primary power piston so that the holes at the base of the tube are covered.

21. Apply silicone lubricant to the O.D. of the primary power piston tube.

22. Remove the primary piston assembly from Tool J-23101 and lay it aside.

23. Assemble the secondary diaphragm to the secondary support plate from the side of the support plate opposite the locking tangs. Press the raised flange on the I.D. of the diaphragm through the center hole of the support plate. Be sure that the edge of the support plate center hole fits into the groove in the raised flange of the diaphragm. Apply a thin coat of silicone lubricant to the I.D. of the secondary diaphragm and the raised surface of the flange (that fits into a groove in the secondary power piston).

24. Mount Tool J-23101 (with large diameter end up) in a vise. Position the secondary power piston so that the radial slots in the piston fit over the ears (tang) of the tool. Apply a light coat of silicone lubricant to the tube of the secondary power piston. See Figure 5A-7.

25. Fold the secondary diaphragm away from the O.D. of the secondary support plate.

26. Holding the edges of the support plate, with the locking tangs down, place the secondary diaphragm and support plate assembly over the tube of the secondary power piston. The flange on the I.D. of the secondary diaphragm will fit into the groove in the secondary piston.

27. Grip the edges of the secondary support plate, press down, and rotate counterclockwise until the tabs on the secondary power piston contact the stops on the support plate. Fold the secondary diaphragm back into position on the secondary support plate. Leave the secondary power piston assembly on Tool J-23101 in the vise. See Figure 5A-9.

28. Apply a light coat of talcum powder or silicone lubricant to the bead on the O.D. of the secondary diaphragm. This will facilitate reassembly of front and rear housings.

29. Place the secondary diaphragm support ring on the secondary power piston assembly so that it rests on the edge of the diaphragm.

30. Hold the housing divider so that the formed over flange (that holds the primary diaphragm) of the divider faces down. Place the secondary bearing in the I.D. of the divider so that the extended lip of the bearing faces up.

31. Lubricate the I.D. of the secondary bearing with silicone lubricant.

32. Position secondary bearing protector Tool J-23188 on the threaded end of the secondary power piston. See Figure 5A-16.

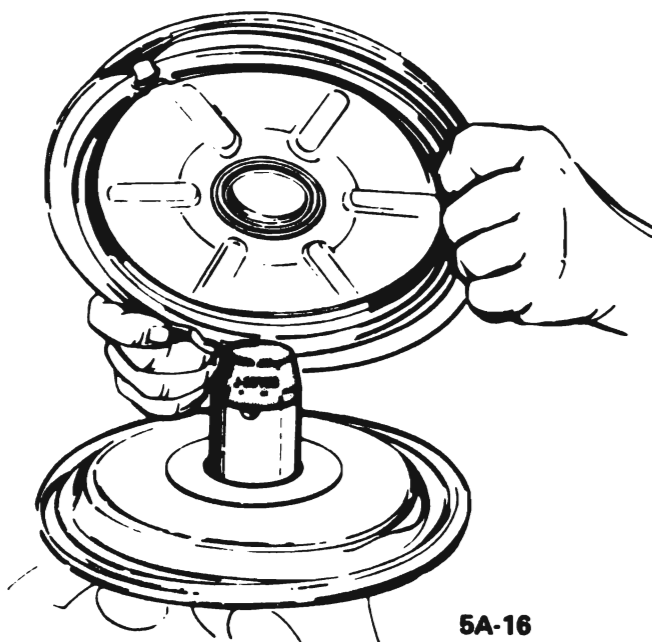

5A-16

Figure 5A-16 Positioning Housing Divider Over Secondary Bearing Protector Tool J-23188

33. Hold the housing divider so the six oblong protrusions on the middle of divider face up. Press the divider down over the tool and onto the secondary power piston tube where it will rest against the diaphragm support ring. Remove Tool J-23188 from secondary power piston; however, do not remove the secondary power piston sub-assembly from Tool J-23101.

34. Pick up the primary power piston assembly and fold the primary diaphragm away from the O.D. of the primary support plate.

35. Position the small end of the air valve return spring on the air valve so that it contacts the air valve retaining ring.

36. Position the primary power piston on the tubular portion of the secondary power piston, making sure that the air valve return spring seats down over the raised center section of the secondary piston.

37. Grip the edge of the primary support plate, press down, and start the threads on the secondary power piston into the threaded portion of the primary power piston by rotating in clockwise direction. See Figure 5A-8.

38. Continue to tighten the primary power piston until it is securely attached (approximately 5-15 ft. pounds) to the secondary power piston.

39. Fold the primary diaphragm back into position on the primary support plate and pull the diaphragm O.D. over the formed flange of the housing divider. Check that the bead on the diaphragm is seated evenly around the complete circumference.

40. Wipe a thin film of silicone lubricant on the O.D. of the piston rod retainer. Insert the master cylinder piston rod retainer into the cavity in the secondary power piston so that the flat end bottoms against the rubber reaction disc in the bottom of the cavity.

Reassembly of Rear Housing Group

1. Place the primary power piston bearing in rear housing center hole so that the formed flange of the housing center hole fits into the groove of the primary power piston bearing. The thin lip of the bearing will protrude to the outside of the housing.

2. Coat the I.D. of the primary power piston bearing with silicone lubricant.

Final Assembly

1. Assemble the master cylinder onto the studs on the front housing. The locknuts can be assembled fingertight on the studs. Mount the front housing

and master cylinder assembly in a vise, clamping on sides of master cylinder vent hole.

2. Position the power piston return spring over the inset in the front housing.
3. Assemble the power piston group to the rear housing by pressing the tube of the primary piston through the rear housing bearing. Press down until the housing divider seats in the rear housing and the primary power piston bottoms against the housing.
4. Place the piston rod retainer plate on the end of the power piston return spring in the front housing.
5. Hold the rear housing assembly (with mounting studs up) over the front housing. (Make sure that the piston rod retainer does not dislodge from the secondary power piston during this operation.) Position the rear housing so that when the tangs on the edge of the front housing are locked in the slots on the edge of the rear housing, the scribe marks on the top of the housings will be in line.
6. Lower the rear housing assembly onto the front housing. Check that the piston rod retainer goes through the center of the retainer plate on the power piston return spring. The retainer plate and power piston spring must seat in the depression in the face of the secondary power piston. Check that the bead on the O.D. of the secondary diaphragm is positioned between the edges of the housing.

7. Continue to press down on the rear housing and fit the slots in the appropriate tangs on the front housing.

8. To facilitate locking, position front housing seal in the depression in the front housing and apply a vacuum source to the vacuum check valve in the front housing. Using Tool J-23456, press down and rotate the rear housing clockwise into the locked position. Remove Tool J-23456; remove the vacuum source. See Figure 5A-4.

9. Place the silencer in the closed end of the power head boot. Push the boot retainer over the boot. Stretch the boot over the push rod and over the flange in the center of the rear housing.

GAUGING DELCO MORAINÉ TANDEM POWER BRAKE UNIT

1. Place the power head assembly in a padded vise (front housing up). *Do not clamp tight!*
2. Insert the master cylinder piston rod, flat end first, into the piston rod retainer.
3. Press down on the master cylinder piston rod

(with approximately a 40-50 pound load) to be sure it is properly seated.

4. Remove the front housing seal to assure that no vacuum is in the power head while gaging.

5. Place Gage J-22647 over the piston rod in a position which will allow the gage to be slipped to the left or right without contacting the studs. See Figure 5A-17.

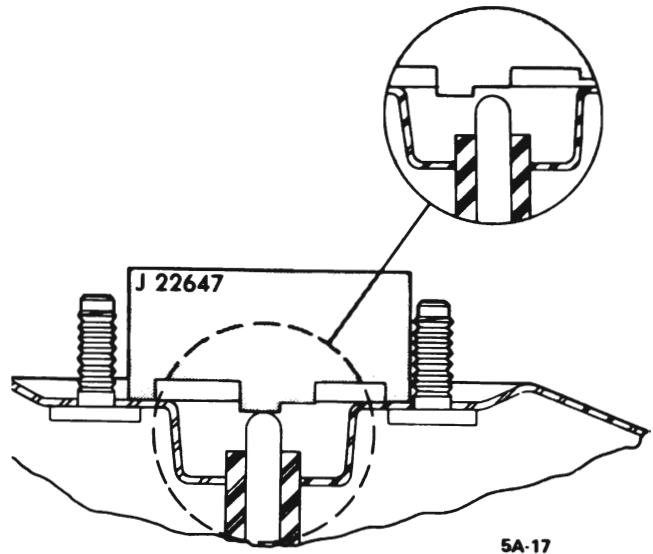

Figure 5A-17 Gaging Piston Rod

6. The center section of the gage has two levels. The piston rod should always contact the longer section (lower level) of the gage. The piston rod should *never* contact the shorter section (higher level) of the gage. Move gage from side to side to check piston rod height.

7. Any variation beyond these two limits must be compensated for by obtaining the service adjustable piston rod and adjusting the self-locking screw to meet the gaging specifications.

8. Wipe a thin film of silicone lubricant on the I.D. of the front housing seal and position seal in the depression in the housing.

DISASSEMBLY OF BENDIX TANDEM POWER BRAKE UNIT

Disassembly of Overall Unit

1. Scribe a line across front and rear housings to facilitate reassembly.
2. Carefully remove hydraulic push rod and seal and slide seal from rod.

3. Remove vacuum check valve and grommet, if required.

4. Remove dust boot and silencer from operating valve rod.

5. Remove dust guard retainer, dust guard and silencers from rear plate hub with an awl. Then, reinstall steel retainer on hub.

6. Squirt alcohol down operating valve rod to lubricate rubber grommet in the valve plunger.

7. Position two small blocks of wood on either side of air valve rod and install end of air valve rod in vise, leaving just enough clearance to position two (2) open end wrenches between vise and retainer on hub of rear plate.

8. Using the wrench nearest the vise as a pry, force the valve plunger grommet off from the ball end of the rod. Do not damage plastic hub or allow vacuum cylinder to fall to the floor. See Figures 5A-21 and 5A-22.

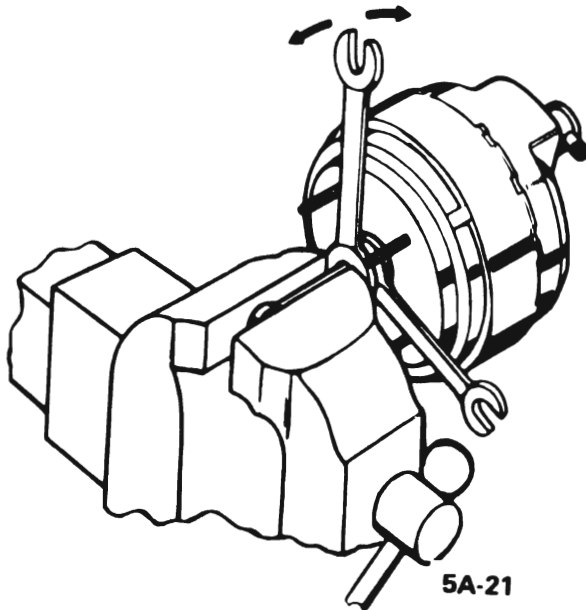

Figure 5A-21 Removing Air Valve Rod

9. The edge of the rear shell contains twelve (12) lances. Four (4) of these lances (one in each quadrant) are deeper than the other lances. The metal that forms the four (4) deep lances must be partially straightened so that the lances will clear the cutouts in the front shell. If the metal tabs that form the deep lances break during straightening, the shell must be replaced. See Figure 5A-23.

10. Remove the hydraulic push rod and vacuum seal from the front shell.

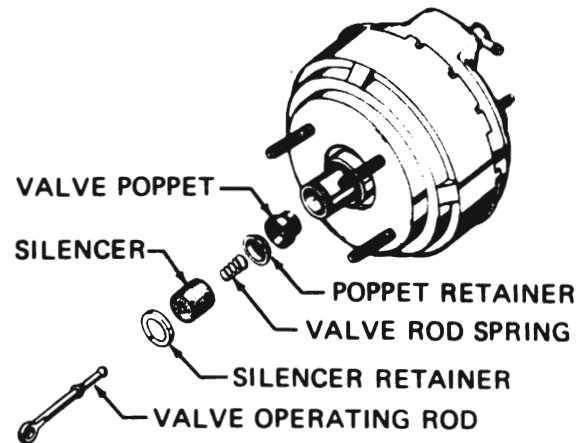

Figure 5A-22 Removing Air Valve Rod

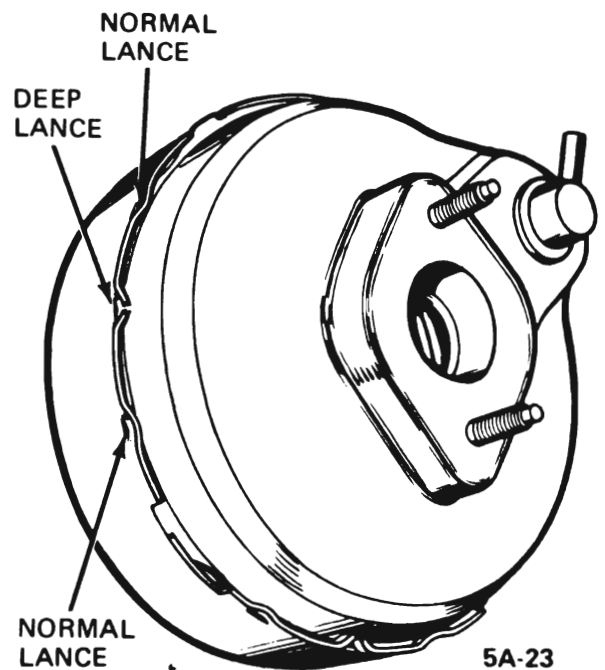
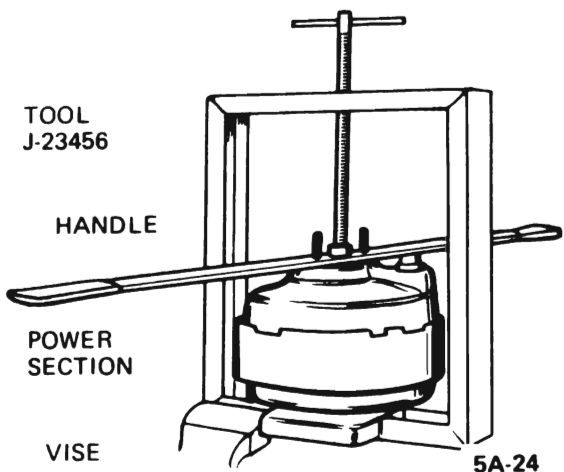

Figure 5A-23 Lances in Front Shell

11. Mount Tool J-23456 in a vise, and position the power section on the rear shell so that the four (4) studs on the rear shell fit into holes in the tool. See Figure 5A-24.

12. Position the handle over the two (2) studs on the front shell and tighten the screw to apply a downward pressure on the front shell. Then, rotate the wrench and front shell counterclockwise until the lances in the edge of the rear shell are aligned with cutouts in the front shell. Considerable effort may be required to rotate the front shell.

13. Slowly release the screw of the tool to permit the two (2) shells to separate.



WARNING: THE DIAPHRAGM RETURN SPRING IS COMPRESSED IN THE POWER SECTION AND EXPANDS AS THE PRESSURE ON THE SHELLS IS REMOVED. IF THE SHELLS DO NOT SEPARATE WHEN THE SCREW HAS BEEN TURNED SLIGHTLY TO REDUCE THE PRESSURE, TAP THE SHELLS WITH A RUBBER HAMMER TO BREAK THE BOND.

14. Continue to release the screw until diaphragm spring tension has been removed.

15. Remove the front shell and return spring.

16. Work edges of front diaphragm from under lances of rear housing and remove complete vacuum

Figure 5A-24 Unlocking Front and Rear Housings

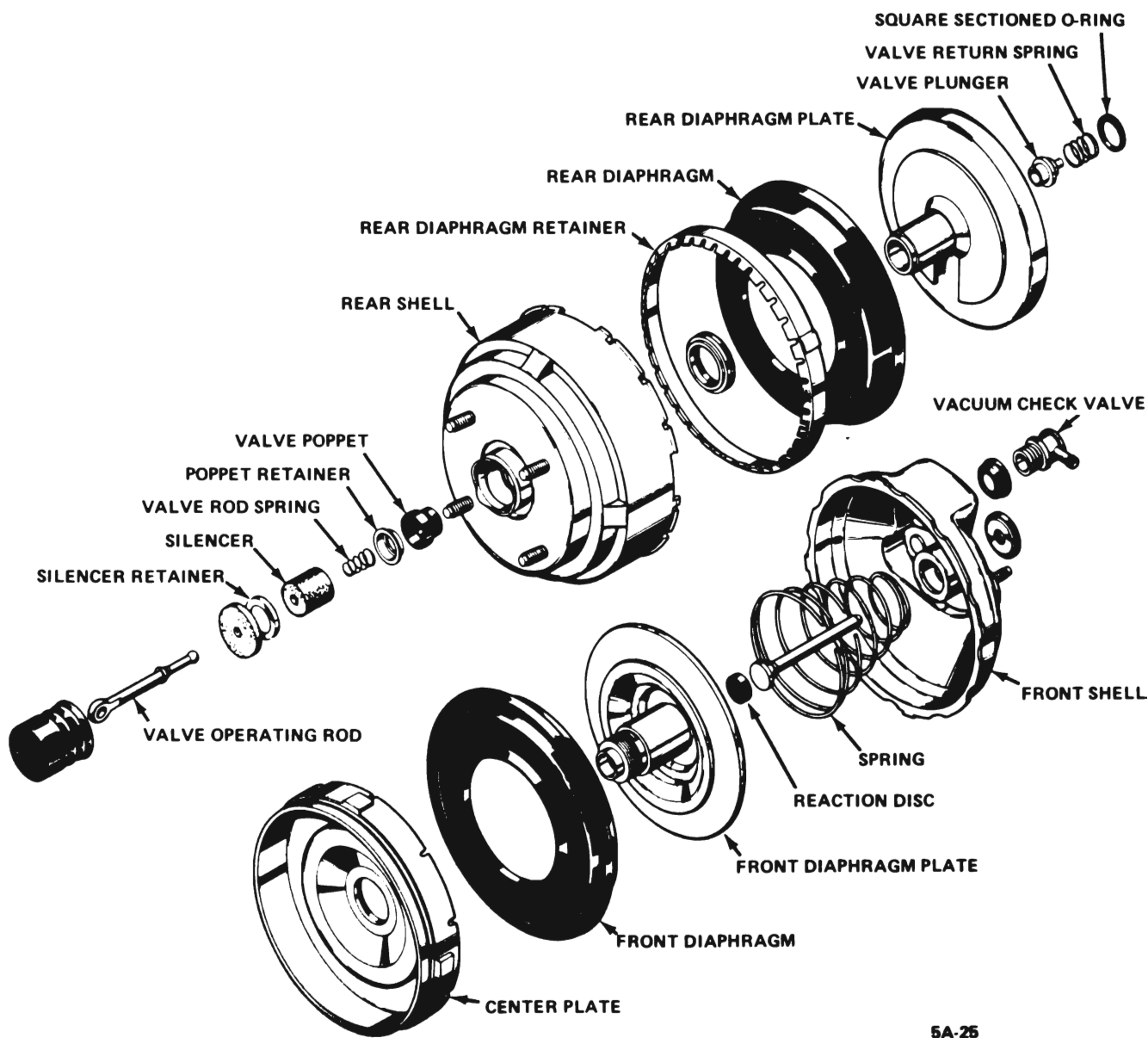

Figure 5A-25 Diaphragm and Plates

assembly from rear housing, using care not to damage rear housing seal. Bosses on center plate must be aligned with cutouts in rear housing to remove the assembly.

17. Wet the rear diaphragm retainer with alcohol and remove the retainer using fingers only.

18. Clamp Tool J-22839 in a vise. Place the diaphragm and plate assembly on the tool with the tool seated in the hex opening in the front plate.

19. Twist the rear diaphragm plate counterclockwise, using hand leverage on the outer edge of the plate. It may be necessary to use a 1" x 1-3/16" x 8" wood strip as a lever in cover slot on outside circumference of rear plate.

20. After the two (2) plates have been loosened, remove the plates from Tool J-22839 and place on a bench with the front plate down. Unscrew the rear plate completely and carefully lift it off the front plate hub, grasping the valve plunger and valve return spring as the parts are separated. See Figure 5A-25.

21. Remove the square sectioned O-ring from the shoulder of the front diaphragm plate hub.

22. Remove the reaction disc from inside the front diaphragm plate hub. Carefully slide the center plate off the hub of the front plate. 23. Remove the diaphragms from the plates.

24. If rear housing seal requires replacement, use a blunt punch or 1-1/4" socket to drive seal from housing. See Figures 5A-26 and 5A-27.

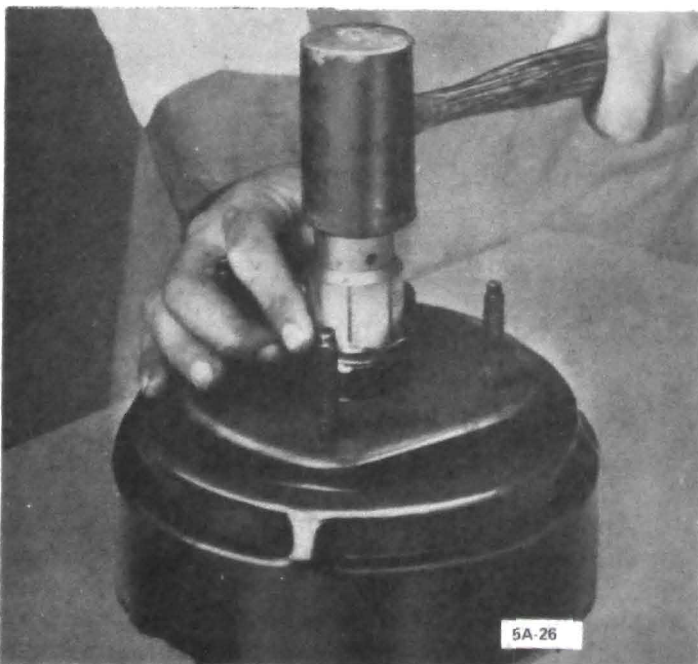
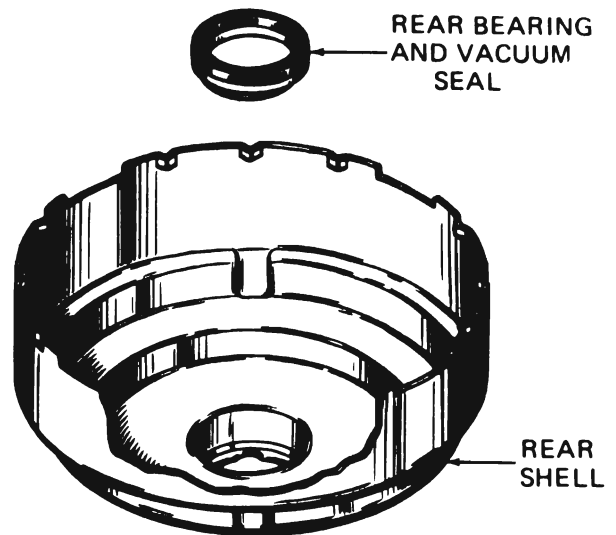

Figure 5A-26 Removing Rear Seal



5A-27

Figure 5A-27 Rear Bearing and Rear Shell

CLEANING AND INSPECTING BENDIX TANDEM POWER BRAKE UNIT

Power Section

All parts to be reused should be washed in alcohol or brake fluid. Dry the parts with compressed air and place them on clean paper or lintfree cloth.

Small rust spots inside the shells may be removed with crocus cloth or fine emery cloth. Be sure to clean thoroughly after using any abrasive.

Inspect all parts and replace any that are damaged or show excessive wear.

REASSEMBLY OF BENDIX TANDEM POWER BRAKE UNIT

1. If the rear bearing and seal were removed, press new bearing and seal into this cavity in the rear shell using Tool J-22677. See Figure 5A-28. The flat rubber surface of the seal should be 5/16" below the flat, inside surface of the rear shell.

2. Install reaction disc in hub of front plate with small tip toward hole. Use rounded rod to seat disc.

3. Mount Tool J-22839 in vise.

4. Install front diaphragm on front plate. Long fold of diaphragm must be facing down.

5. Install Tool J-22733 over threads on front plate hub. See Figure 5A-29.

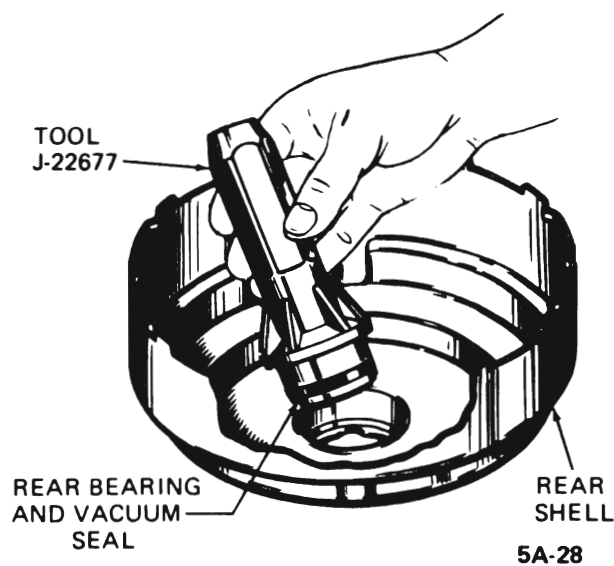

Figure 5A-28 Installing Rear Bearing and Vacuum Seal

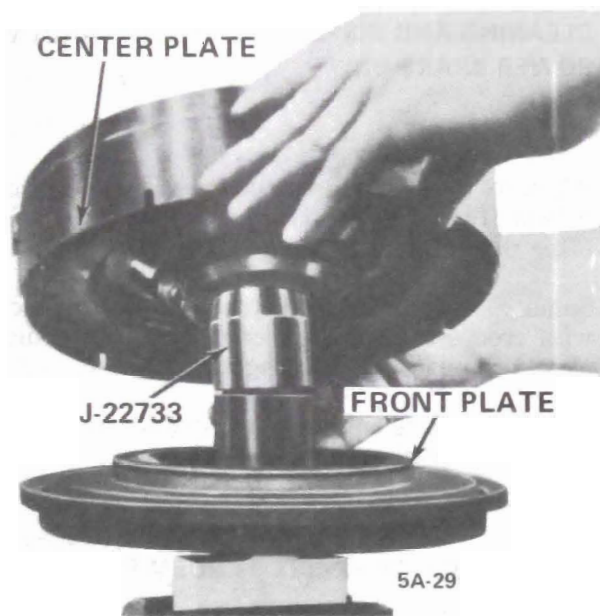

Figure 5A-29 Seal Protector Tool J-22733

6. Apply a light film of special seal lubricant to front plate hub and to seal in center plate, then guide center plate, seal first, onto the front plate hub, being careful not to damage center plate seal.

7. Apply special seal lubricant lightly to front and rear bearing surfaces of air valve plunger, being careful not to apply lubricant to rubber grommet inside plunger. Install vacuum seal O-ring on shoulder of front plate hub and valve plunger return spring and plunger in base of front plate hub. See Figure 5A-30.

8. Set rear plate over hub of front plate and, using hands only, screw plate on hub, making sure that



Figure 5A-30 Installing Air Valve Plunger

valve and spring are properly aligned. Hand torque plates to 150 in.lbs. Check travel of valve plunger with index finger.

9. Assemble rear diaphragm to rear plate and place lip of diaphragm in groove in rear plate. Install diaphragm retainer over rear diaphragm and lip of center plate. Using fingers, press retainer until it seats on shoulder of center plate. See Figure 5A-31.

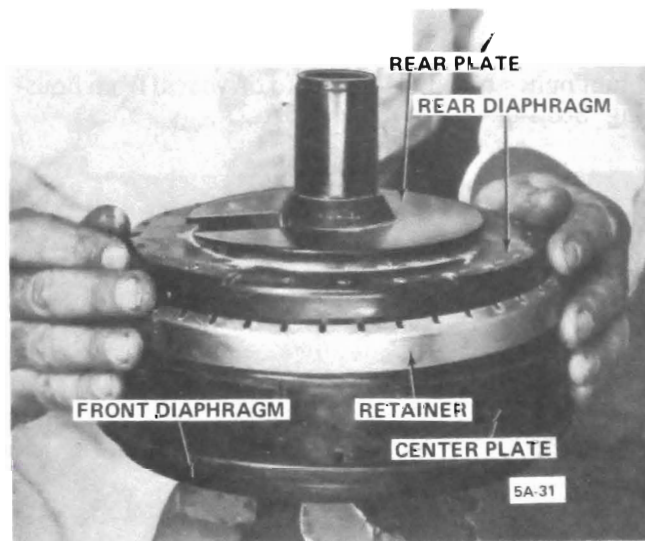

Figure 5A-31 Installing Rear Diaphragm Retainer

10. Apply talcum powder to inside wall of rear housing and special seal lubricant to the scalloped cutouts of front housing and to seal in rear housing; assemble diaphragm and plate assembly into rear housing by carefully guiding rear plate hub through seal in rear housing. Bosses on center plate must be aligned between lances in rear housing for reassembly. Work

10. Apply talcum powder to inside wall of rear housing and special seal lubricant to the scalloped cutouts of front housing and to seal in rear housing; assemble diaphragm and plate assembly into rear housing by carefully guiding rear plate hub through seal in rear housing. Bosses on center plate must be aligned between lances in rear housing for reassembly. Work outer rim of front diaphragm into rear housing with screwdriver blade so that it is under lances in housing.

11. Install rear housing in Tool J-23456.

12. Install diaphragm return spring in rear housing.

13. Place front housing over rear housing and align scribe marks.

14. Tighten until diaphragm edge is fully compressed and tangs on front housing against slots on rear housing.

15. Rotate bar clockwise until housings are locked together. Remove from tool.

16. Bend the tabs of the four deep lances back to their original position.

17. Wet poppet valve with alcohol and assemble in rear plate hub, small end first; wet poppet retainer with alcohol and assemble with shoulder inside poppet. Assemble retainer, filters, silencer over ridge on rod and return spring over ball end of operating valve rod. Wet grommet in valve plunger with alcohol and guide air valve rod into valve plunger. Tap end of operating valve rod with plastic hammer to lock ball in grommet. Press filters and silencers into hub and install retainer on hub.

18. Assemble silencer in dust boot, wet dust boot opening with alcohol and assemble over operating valve rod and over flange of rear housing.

19. Install check valve and grommet, if removed.

20. Apply special seal lubricant to piston end of hydraulic push rod and insert in cavity in front plate. Twist rod to eliminate air bubbles at reaction disc. Assemble seal over push rod and press into recess in front housing.

GAUGING OF BENDIX TANDEM POWER BRAKE UNIT

1. Place the power head assembly in a padded vise (front housing up). *Do not clamp tight.*

2. Insert the master cylinder piston rod, flat end first, into the piston rod retainer.

3. Press down on the master cylinder piston rod (with approximately a 40-50 pound load) to be sure it is properly seated.

4. Remove the front housing seal to assure that no vacuum is in the power head while gauging.

5. Place Gauge J-22647 over the piston rod in a position which will allow the gauge to be slipped to the left or right without contacting the studs. See Figure 5A-32.

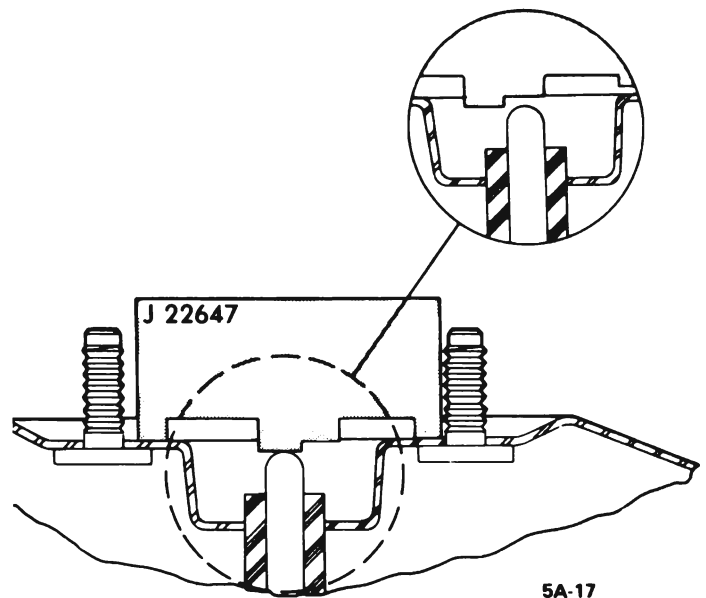

Figure 5A-32 Gauging Piston Rod

DISASSEMBLY OF DELCO MORAINÉ POWER BRAKE UNIT

Disassembly of Power Brake Unit

1. Scribe a mark on bottom center of front and rear housings to facilitate reassembly.

2. Using holder J-22805-01 and Handle J-9504-01, rotate rear housing counterclockwise to unlocked position. See Figure 5A-36. Loosen housing carefully as it is spring-loaded.

3. Lift rear housing and power piston assembly from unit. Then remove return spring.

4. Remove clevis and jam nut from push rod. Remove retaining ring on push rod that holds silencer in place on push rod. Remove silencer.

5. Reposition master cylinder assembly in vise to facilitate removal of front housing from master cylinder. Remove master cylinder to front housing attaching nuts.

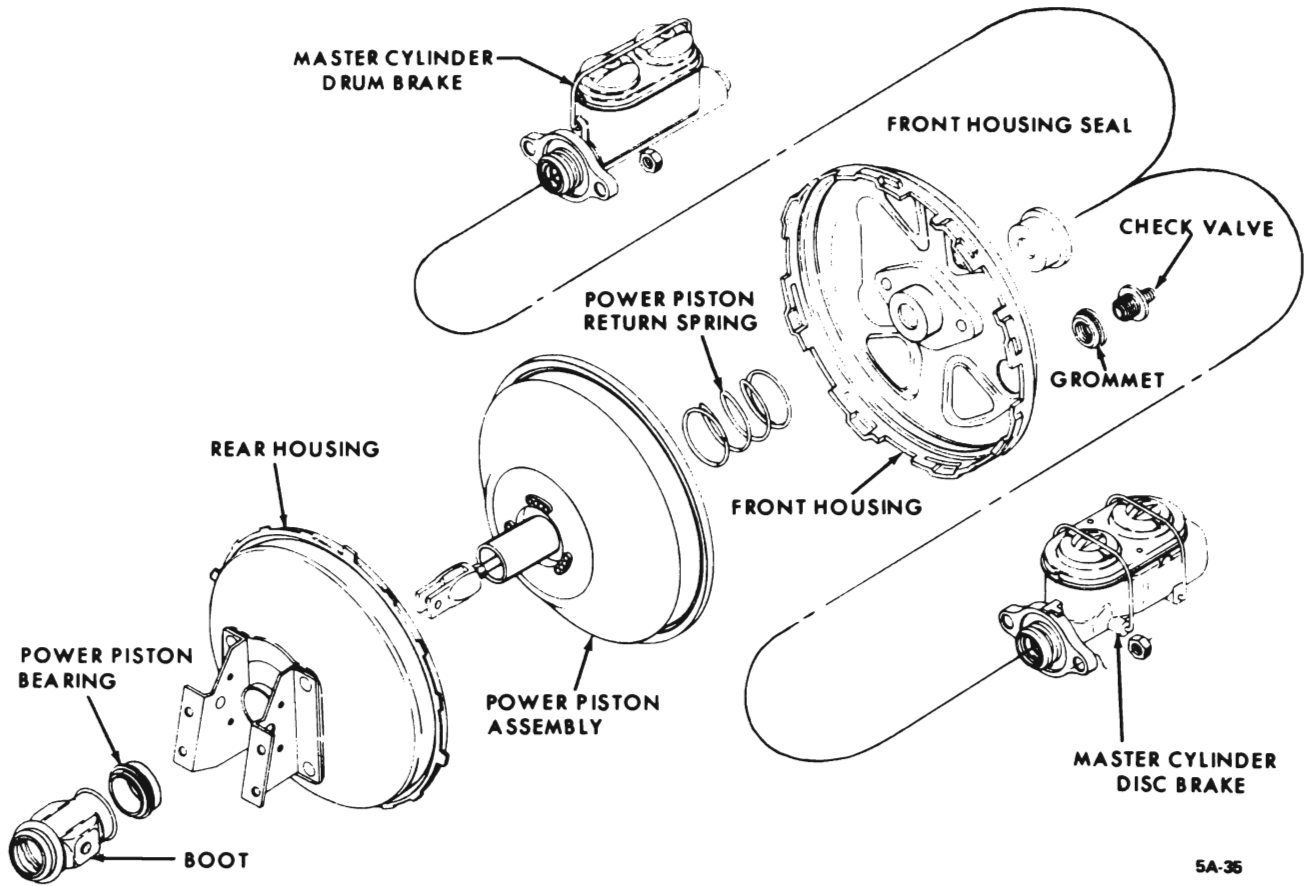

Figure 5A-35 Power Brake Unit - Exploded View

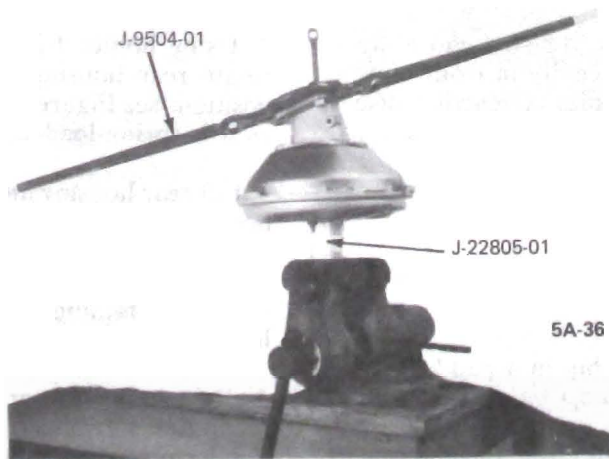
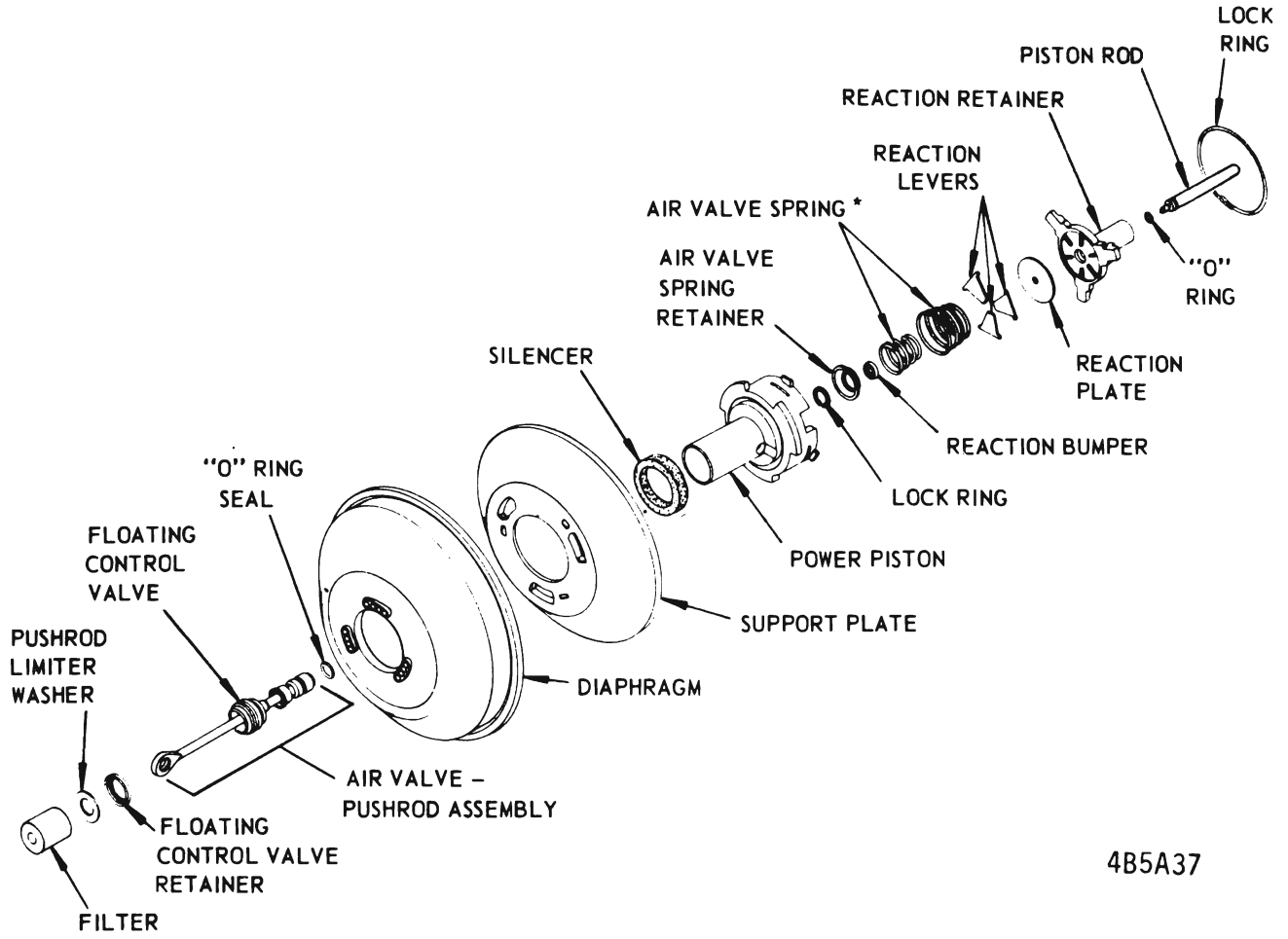

Figure 5A-36 Separating Power Brake Unit



4B5A37

Figure 5A-37 Power Piston Assembly - Exploded View

6. Remove seal from front housing, and if defective, vacuum check valve.

Disassembly of Power Piston Assembly

CAUTION: Care must be used in handling the diaphragm of power piston assembly. Guard diaphragm against grease, oil, foreign matter and nicks or cuts.

1. Remove power piston assembly from rear housing.
2. Remove silencer from neck of power piston tube.
3. Remove lock ring from power piston by prying one end out from under large divided locking lug and then proceed to pull ring from under other two locking lugs on power piston. See Figure 5A-38.

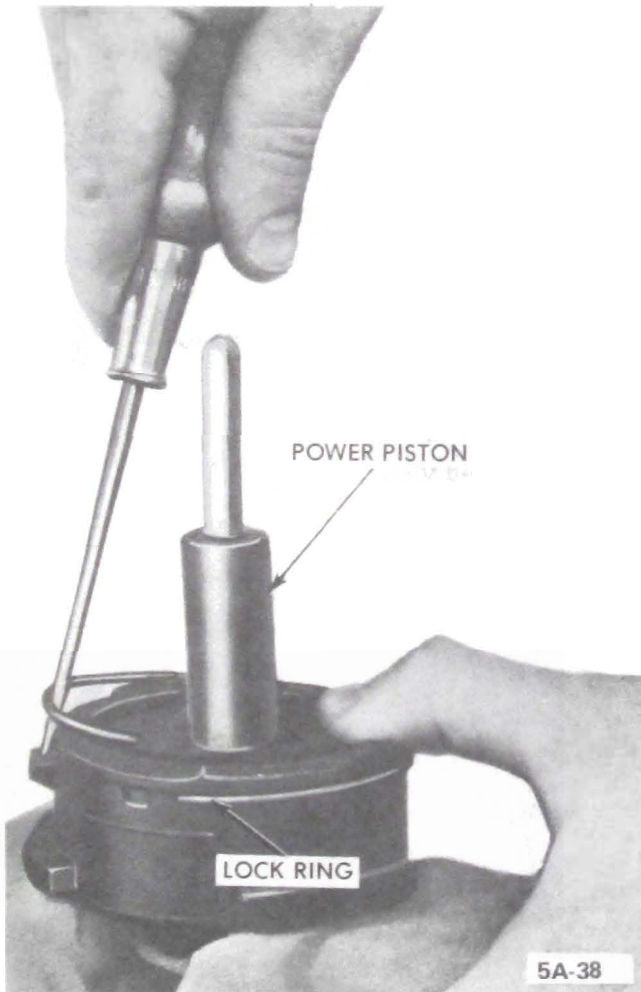

Figure 5A-38 Removing Lock Ring From Power Piston

4. Remove reaction retainer, piston, reaction plate, three (3) reaction levers and air valve spring. Also remove reaction bumper and air valve spring retainer from air valve. See Figure 5A-39.

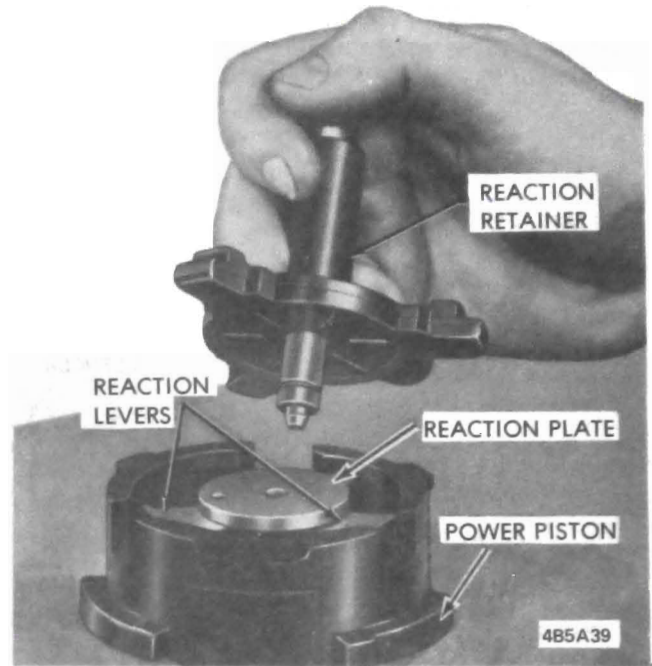

Figure 5A-39 Removing Reaction Retainer

5. Place power piston Wrench J-21524 with square shank in vise. Hold support plate and power piston with tube of power piston up. See Figure 5A-40.

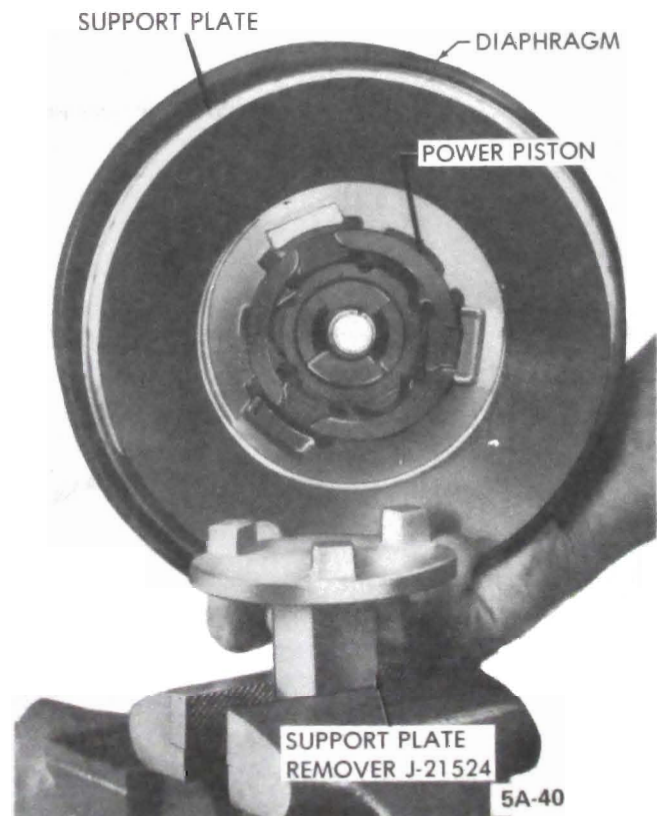

Figure 5A-40 Positioning Support Plate Retainer in Vise

6. Pull diaphragm edges away from support plate so hands can grip steel support plate. Position assembly on power piston Wrench J-21524 so three lugs on tool fit into three notches in power piston. See Figure 5A- 41.



Figure 5A-41 Positioning Power Piston on Support Plate Remover

7. Press down on support plate and rotate counterclockwise until support plate separates from power piston. See Figure 5A-42.

8. Remove diaphragm from support plate and lay both parts aside.

9. Position power piston, tube down, in a tool, fabricated from a piece of wood, 2" x 4" x 8" long with a 1-3/8" hole in center, clamped in a vise. Do not clamp tube in vise.

10. Use No. 22 Truarc Pliers or J-4880 to remove snap ring on air valve. See Figure 5A-43.

11. Set up Power Ram and Hydraulic Pump with J-9746 Press Plate. Insert power piston, tube down, in press plate and remove air valve assembly using a 3/8" drive extension as a remover. See Figure 5A-44.

12. Removal of air valve push rod assembly disassembles the following parts from power piston: float-

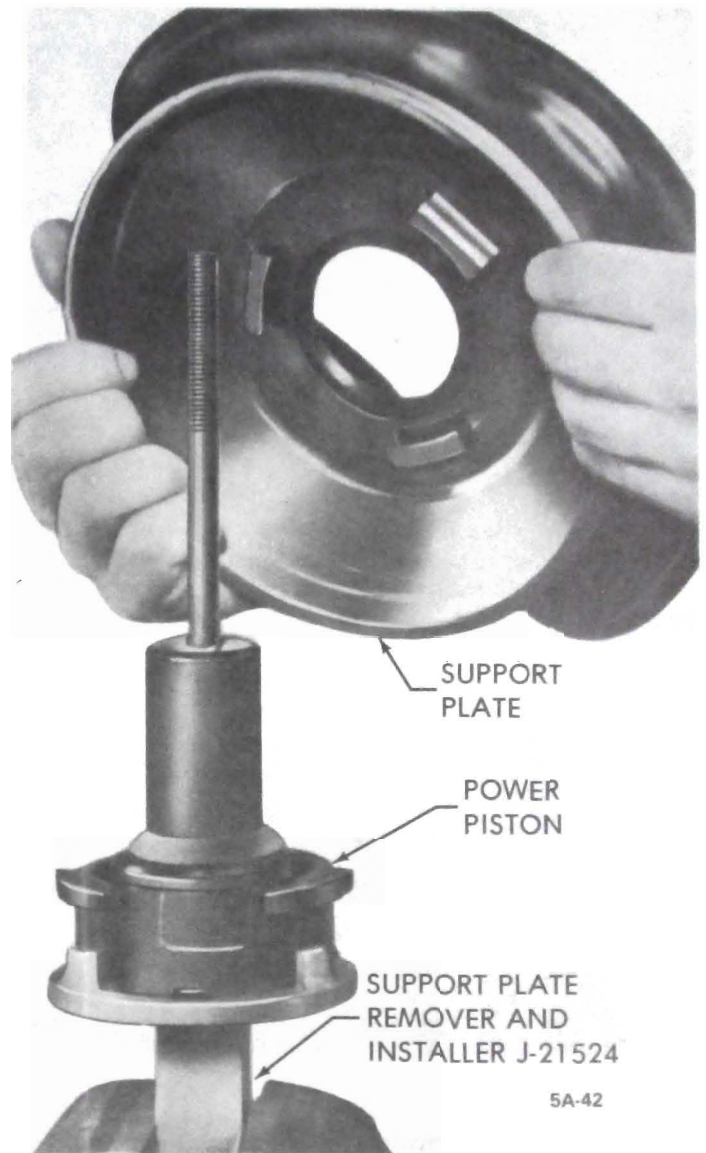

Figure 5A-42 Removing Support Plate

-ing control valve assembly, floating valve retainer, push rod limiter washer and air filter.

13. Remove floating control valve assembly from push rod as it must be replaced by a new floating control valve assembly at rebuild.

14. The master cylinder push rod can now be pushed from center of reaction retainer. Remove "O" ring from groove in master cylinder piston rod.

CLEANING AND INSPECTION OF DELCO MORAINÉ POWER BRAKE UNIT

Cleaning of Parts

1. Use Declene or denatured alcohol to clean thoroughly all metal brake parts. Immerse in cleaning fluid and brush with hair brush to remove foreign matter. Blow out all passages, orifices and valve

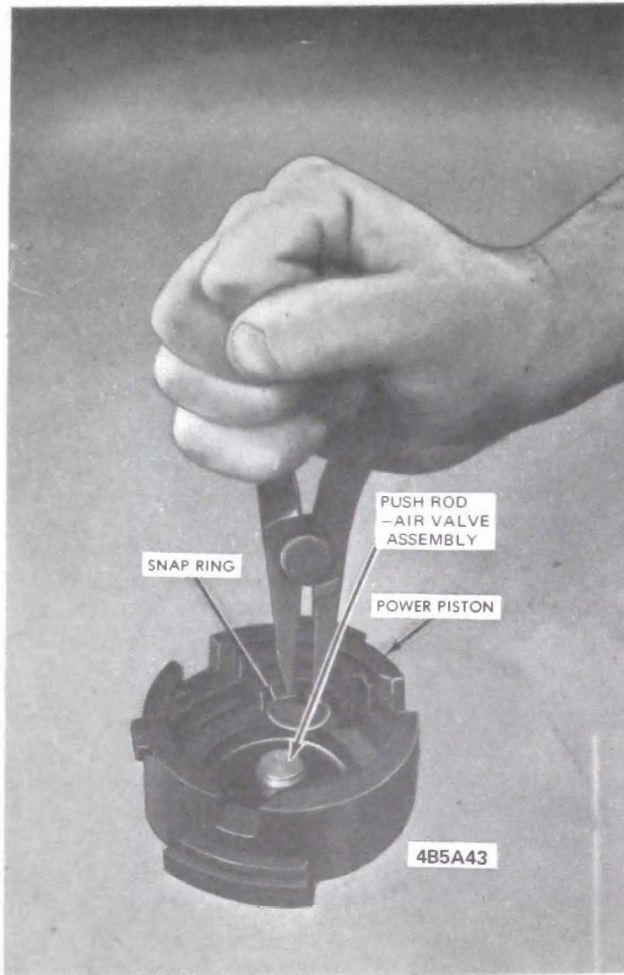

Figure 5A-43 Removing Power Piston Snap Ring

holes. Air dry and place cleaned parts on clean paper or lint free clean cloth.

2. If slight rust is found inside either front or rear housing assemblies, polish clean with crocus cloth or fine emery paper, washing clean afterwards with specified cleaning fluid.

CAUTION: *If there is any suspicion of contamination or any evidence of corrosion, completely flush hydraulic brake system in accordance with Paragraph 5A-13. Failure to clean hydraulic brake system can result in early repetition of trouble. Use of gasoline, kerosene, anti-freeze alcohol or any other cleaner with even a trace of mineral oil will damage rubber parts.*

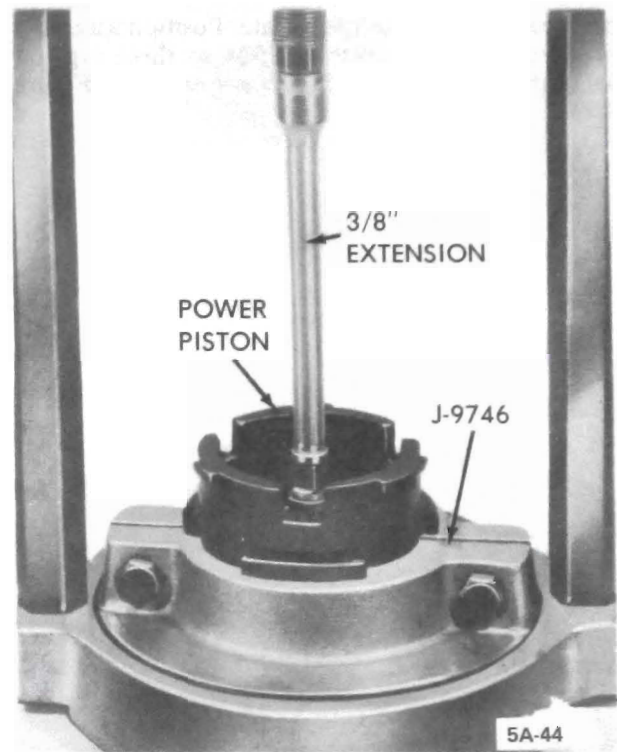

Figure 5A-44 Removing Air Valve Assembly

Dirt is the major cause of trouble and wear in service. Be sure to keep parts clean. Rewash at reassembly if there is any occasion to doubt cleanliness--such as parts dropped or left exposed for eight hours or longer.

Inspection and Replacement of Parts

1. Inspect all rubber parts. Wipe free of fluid and carefully inspect each rubber part for cuts, nicks or other damage. These parts are the key to control of fluid or air flow and should account for the majority of troubles traceable to leakage. Re-use rubber parts only if a fairly new unit is disassembled for some particular trouble and only then if there is no doubt that the parts are in equal-to-new condition. Badly damaged items or those which would take extensive work or time to repair should be replaced. In case of doubt, install new parts for safety and for ultimate lower cost.

2. Inspect in accordance with Inspection Table: (The table is organized by power brake unit groups.)

Inspection Table

Part	Inspect For	Corrective Action
Power Piston and Support Plate and Reaction Retainer	1. Cracks, distortion, chipping, damaged lever seats, pitted or rough holes.	1. Clean up or replace.
	2. Worn seal surfaces (tubes).	2. Replace
	3. Rough or uneven floating valve seat.	3. Replace
	4. Open passages and flow holes.	4. Clean
Reaction Levers or Plates	1. Cracks, distortion, tears and heavy wear.	1. Replace
Floating Control Valve	1. Deterioration of rubber or warped valve face.	1. Replace
Air Valve - Push Rod Assembly	1. Air valve: scratches, dents, distortion, or corrosion of I.D. or O.D. All seats to be smooth and free of nicks and dents.	1. Do not repair - replace.
	2. Push rod must move freely in air valve, but must not pull out.	2. If worn, replace air valve - push rod assembly.
Front and Rear Housing	1. Scratches, scores, pits, dents, or other damage affecting rolling or sealing of diaphragm or other seals.	1. Replace, unless easily repaired.
	2. Cracks, damage at ears, damaged threads on studs.	2. Replace, unless easily repaired.
	3. Bent or nicked locking lugs.	3. Replace, unless easily repaired.
	4. Loose studs.	4. Replace or repair.
Air Filters and Silencer	1. Dirty	1. Replace

ASSEMBLY OF DELCO MORAINE POWER BRAKE UNIT

Be certain that all rubber parts are clean at reassembly. Rewash in specified cleaning fluid if there is any doubt of cleanliness. Be careful during rebuild process that no grease or mineral oil comes in contact with rubber parts of power brake unit. Lubricate rubber parts with Delco Moraine approved lubricant or equivalent.

Assembly of Front Housing Group

1. Replace vacuum check valve using a new grommet if old one is cracked or damaged.
2. Place new front housing seal in housing so flat surface of cup lies against bottom of depression in housing.
3. Install hydraulic master cylinder on front housing. Do not tighten nuts as master cylinder must again be removed for gaging.

Assembly of Power Piston Group

1. Place new "O" ring in groove on the master cylinder piston rod. Wipe a thin film of Power Brake Lube or equivalent on "O" ring.
2. Master cylinder piston rod is now inserted through the reaction retainer so round end of piston rod protrudes from end of the tube on reaction retainer.
3. Place J-21524 power piston wrench in a vise. Position power piston on wrench with three lugs fitting into notches in power piston.
4. Position new "O" ring on air valve in second groove from push rod end.
5. On reassembly of power piston, floating control valve assembly must be replaced with a new one since the force required to remove it distorts component parts.
6. Place floating control valve on push rod-air valve assembly so flat face of valve will seat against valve seat on air valve.
7. Wipe a thin film of Power Brake Lube on large O.D. of floating control valve and on "O" ring on air valve.
8. Press air valve-push rod assembly, air valve first, onto its seat in tube of power piston.
9. Place floating control valve retainer over push rod so flat side seats on floating control valve.
10. Start floating control valve and its retainer into

power piston tube. Press the floating control valve to seat in the tube, by placing J-21601 Floating Control Valve Retainer Installer on top of retainer and pushing down by hand. See Figure 5A-45.

11. After floating control valve is seated, position push rod limiter washer over push rod and down onto floating control valve. Air filter element can now be stretched over end of push rod and pressed into power piston tube.
12. Assemble power piston diaphragm to diaphragm support plate from side of support plate opposite locking tangs. The raised flange of diaphragm is pressed through hole in center of support plate. Be sure that edge of center hole fits into groove in flange of diaphragm.
13. Pull diaphragm away from O.D. of support plate support plate can be gripped with hands.
14. With power piston still positioned on holding tool in vise, coat bead of diaphragm that contacts power piston with Power Brake Lube.

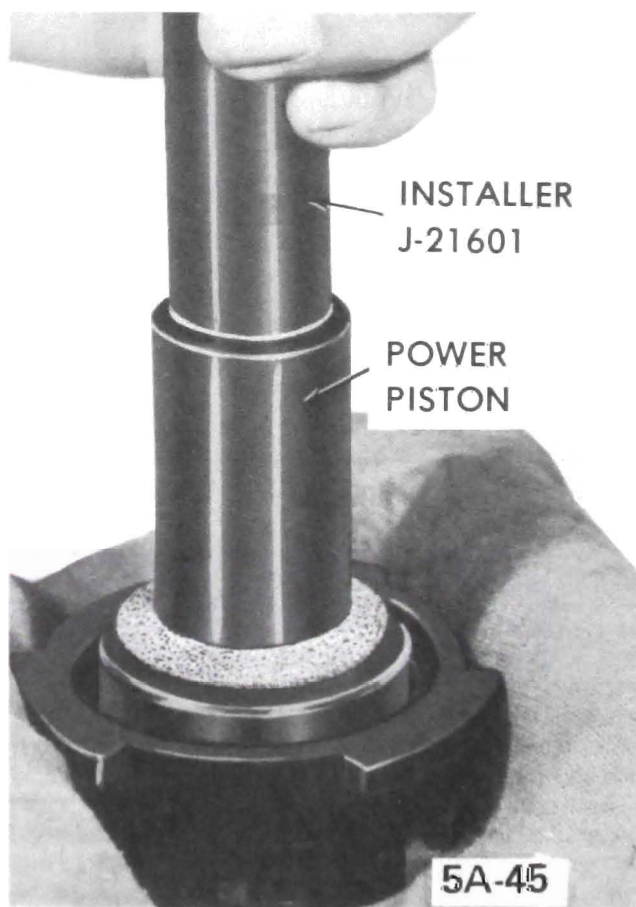

Figure 5A-45 Installing Floating Control Valve Assembly

15. Holding support plate by metal, with locking tangs down, place support plate and diaphragm assembly over tube of power piston. The flange of diaphragm will fit into groove on power piston. See Figure 5A-46.

16. Press down and rotate support plate clockwise, until lugs on power piston come against stops on support plate. See Figure 5A-46.

17. This assembly can now be turned over and placed, tube down, in a tool, fabricated from a piece of wood, 2" x 4" x 8" long with a 1-3/8" hole in the center, clamped in a vise.

18. With a pair of No. 22 Truarc or J-4880 Pliers, assemble snap ring into groove in air valve.

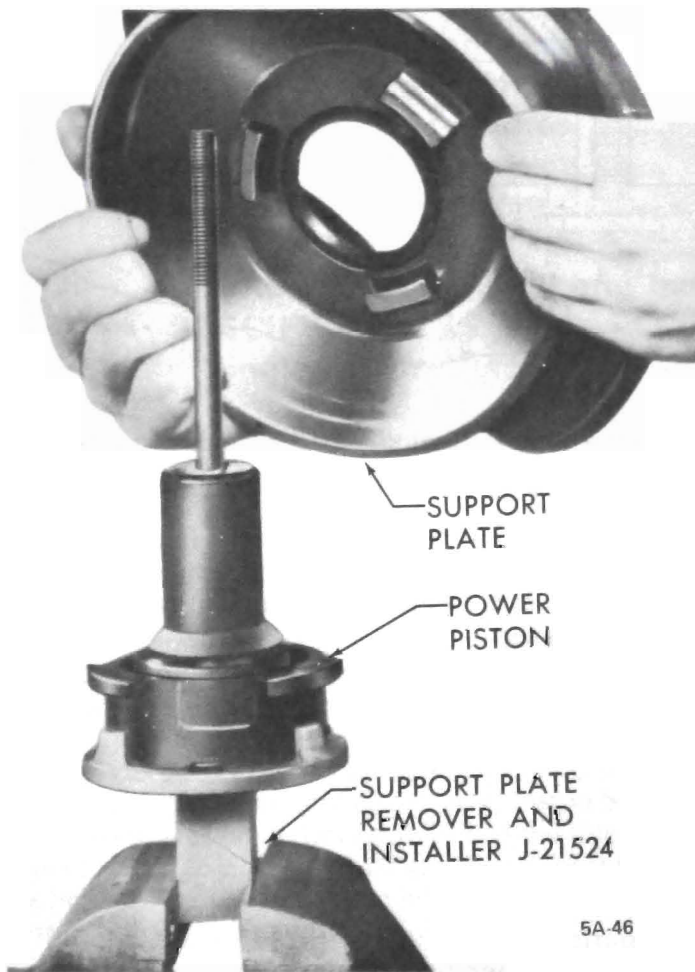

Figure 5A-46 Installing Power Piston into Support Plate

19. Place air valve spring retainer on snap ring. Assemble reaction bumper into groove in end of air valve.

20. Position air valve return spring, large end down, on spring retainer.

21. The three reaction levers are now placed into position with ears on wide end in slots in power

piston. The narrow ends will rest on top of air valve return spring.

22. Position reaction plate (with numbered side up) on top of reaction levers. Press down on plate until large ends of reaction levers pop up so plate rests flat on levers. Be sure reaction plate is centered.

23. Master cylinder piston rod and reaction retainer assembly is now assembled to the power piston.

24. With round end of piston rod up, and with reaction retainer held toward top of piston rod, place small end of piston rod in hole in center of reaction plate. Line up ears on reaction retainer with notches in power piston and push reaction retainer down until ears seat in notches.

25. Maintain pressure on reaction retainer and position large lock ring down over master cylinder push rod.

26. There is a lug on the power piston which has a raised divider in the center. One end of lock ring goes under lug and on one side of divider.

27. As you work your way around power piston (either way), the lock ring goes over ear of reaction retainer, under a lug on power piston, and so forth, until other end of lock ring is seated under lug with raised divider.

Be sure both ends of lock ring are securely under large lug.

Assembly of rear Housing Group

1. Place a new power piston bearing in center of rear housing so flange on center hole of housing fits into groove of power piston bearing. The large flange on power piston bearing will be on stud side of housing.

2. Coat inside of power piston bearing with Power Brake Lube.

Final Assembly of Power Brake Unit

1. Place air silencer over holes on tube of power piston. Wipe tube of power piston with Power Brake Lube.

2. Assemble power piston to rear housing.

3. Wipe tube of reaction retainer with Power Brake Lube and lay assembly aside.

4. Place front housing in a vise with master cylinder down. Position power piston return spring over inset in front housing. Lubricate the I.D. of support plate seal with Power Brake Lube.

5. Lightly lubricate beaded edge of diaphragm with Power Brake Lube. Hold rear housing and power piston assembly over front housing with master cylinder push rod down. Position rear housing so that when rotated into locked position, scribe marks on housings will be in line.

6. Using Holder J-22805-01 and Wrench J-9504-01 lock housings together. Do not break studs loose in rear housing or put pressure on power piston tube when locking housings.

7. Push felt silencer over push rod to seat against end of power piston tube. Snap ring retainer is now placed on push rod so it can hold silencer against power piston tube. Plastic boot is now pushed to seat against rear housing. Raised tabs on side of boot will locate in holes in center of brackets. The jam nut and clevis can now be reassembled to push rod.

GAUGING OF DELCO MORAINÉ POWER BRAKE UNIT

The following gaging operation is necessary only when a major structural part such as front or rear housing, power piston assembly, master cylinder piston or master cylinder assembly is replaced with a new part. The gauge measures how far the master cylinder push rod projects from front housing. This dimension must be correct to insure proper clearance in master cylinder between primary cup and compensating port.

Make check as follows:

1. Place power brake assembly in a vise and press master cylinder push rod firmly to seat before gauging.

2. Place gage over piston rod in a position which will allow gage to be slipped to left or right without contacting studs.

The center section of gage has two levels. The piston rod end should always touch the longer section gage which extends into front housing. The piston rod end should never touch the shorter section of gage. See Figure 5A-47.

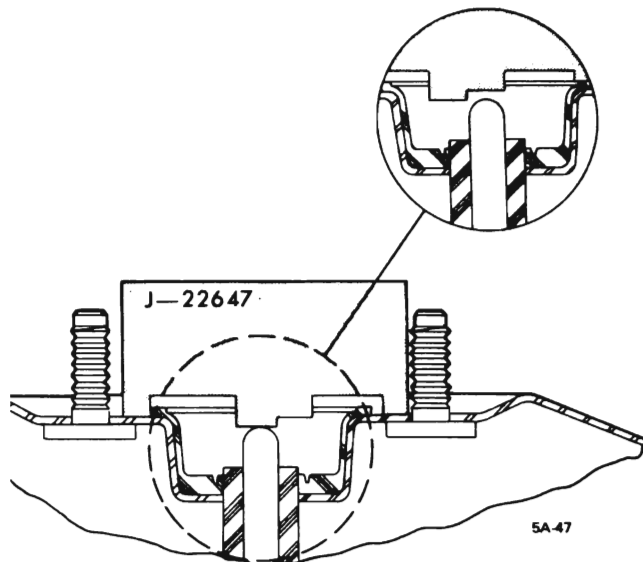

Figure 5A-47 Gaging Master Cylinder Push Rod

3. Any variation beyond these two limits must be compensated for by obtaining the service adjustable piston rod, and adjusting the screw in end to match height of gage.

SPECIFICATIONS

POWER BRAKE SPECIFICATIONS

Tightening Specifications

Use a reliable torque wrench to tighten the parts listed to insure proper tightness without straining or distorting parts. These specifications are for clean and lightly-lubricated threads only; dry or dirty threads produce increased friction which prevents accurate measurement of tightness.

Part	Location	Thread Size	Torque
Nut	Power Brake Unit to Dash	3/8-16	24 lb.ft.
Nut	Master Cylinder to Power Unit	3/8-16	24 lb.ft.
Bolt	Vacuum Hoses Bracket to Engine	3/8-16	15 lb.ft.
Nut	Pipe Assembly to Master Cylinder		150 lb.in.

General Specifications

Operating Mechanism Vacuum-Hydraulic