

AUTOMATIC LEVEL CONTROL - ALL SERIES

CONTENTS

Subject	Page No.
DESCRIPTION AND OPERATION:	
Description and Operation	9F-288
DIAGNOSIS:	
Quick Check of System	9F-293
Compressor Output Test - On Car	9F-294
Pressure Regulator Test	9F-294
Height Control Valve Test	9F-294
Leak Test	9F-295
Trouble Diagnosis Chart	9F-296
MAINTENANCE AND ADJUSTMENTS:	
Trim Adjustment - On Car	9F-309
MAJOR REPAIR:	
Removal and Installation of Tubing	9F-310
Removal and Installation of Compressor, Reservoir and Regulator Valve Assembly	9F-310
Disassembly of Compressor Assembly	9F-311
Cleaning and Inspecting of Parts	9F-313
Assembly of Compressor Assembly	9F-313
SPECIFICATIONS:	
Specifications	9F-315

DESCRIPTION AND OPERATION

The Automatic Level Control System is available on

all series as a factory or dealer installed option. Its function is to maintain automatically the rear standing height of the car, even with load changes of up

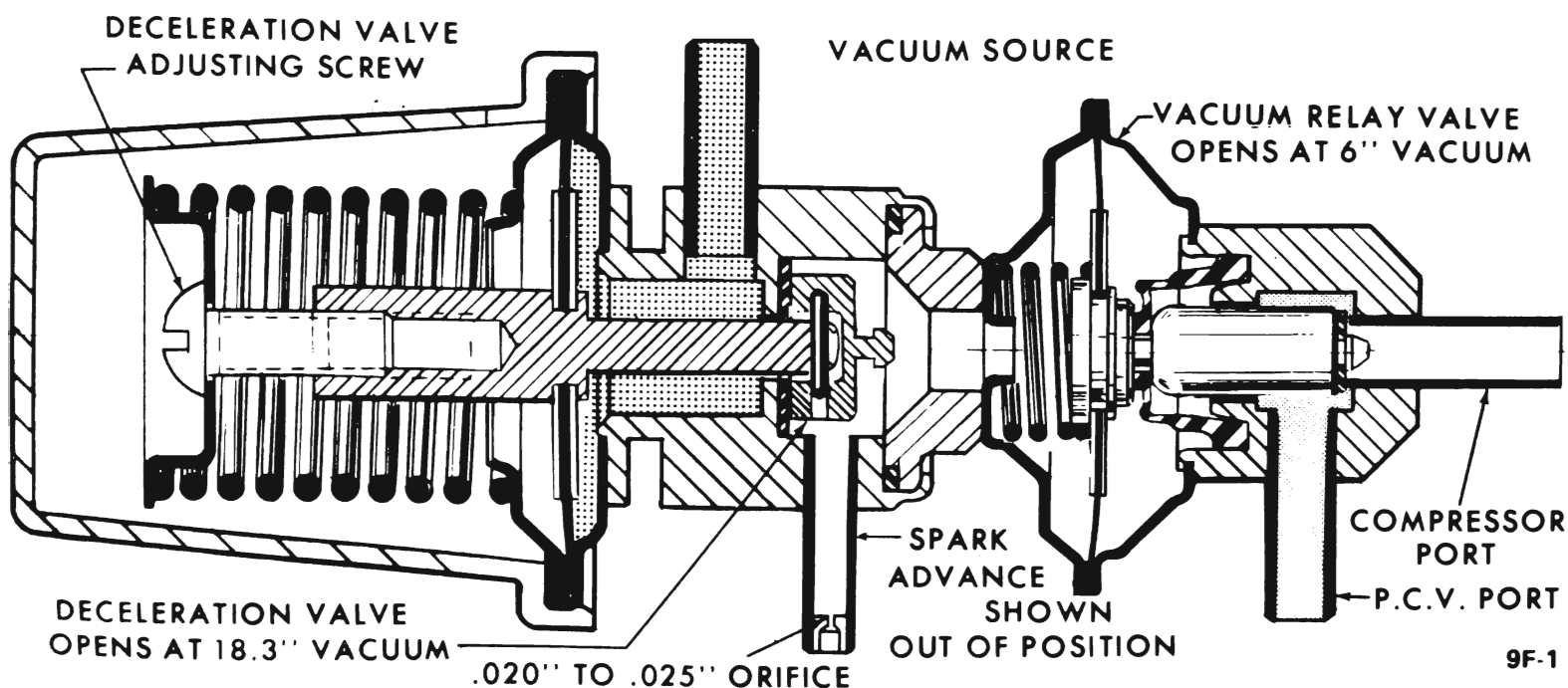

Figure 9F-1 - Slow Idle Condition - Both the Deceleration Valve and the Vacuum Relay Valve are CLOSED

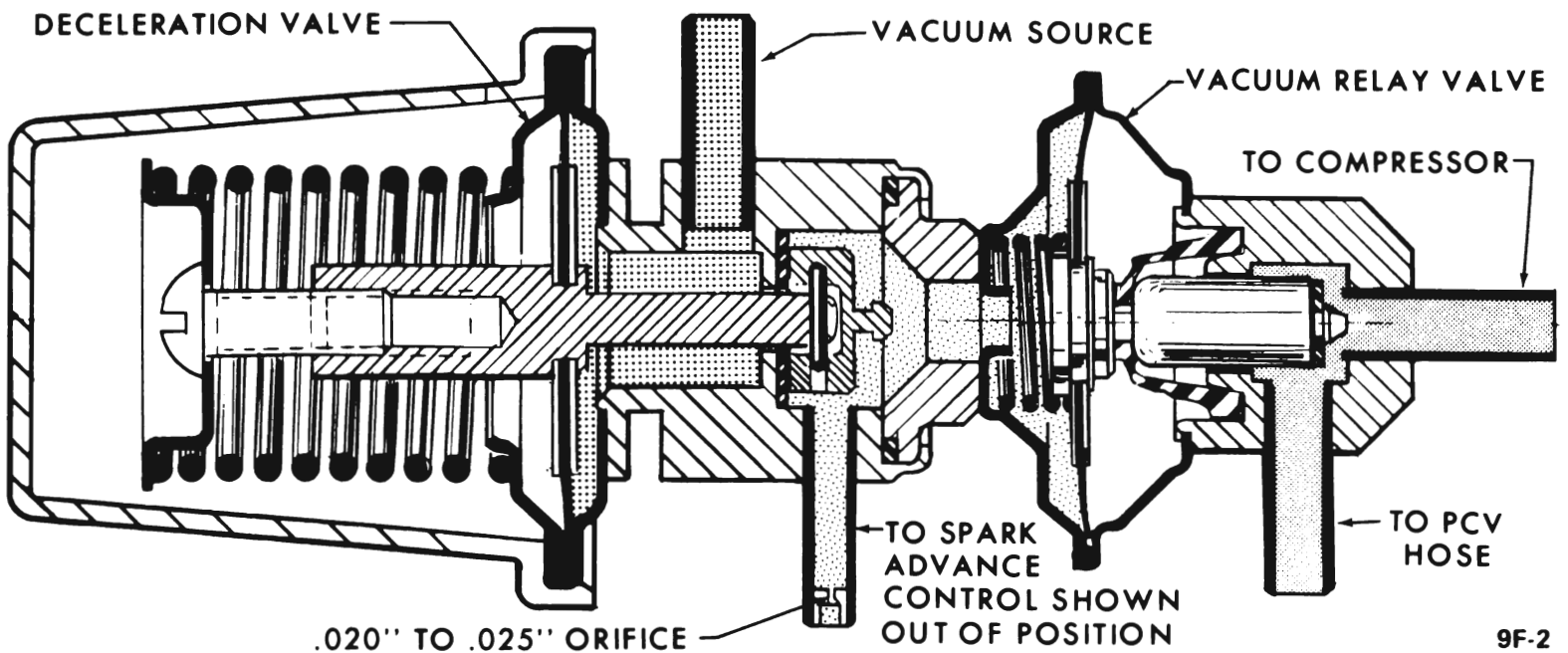

Figure 9F-2 - Fast Idle Condition - Vacuum Relay Valve is OPEN

to 500 pounds placed directly over the rear axle. The system of a vacuum operated air compressor, reservoir tank and pressure regulator assembly, height control valve, link, two Superlift rear shock absorbers and flexible air lines.

The vacuum regulator valve assembly consists of a relay valve which is pre-set to open at 6 inches of vacuum and deceleration valve that is set to open at 18.3 inches of vacuum. The deceleration valve controls the relay during periods of deceleration. The relay valve is connected to the compressor and to the

positive crankcase ventilator line by rubber hose. The spark advance port of the regulator valve assembly is connected into the vacuum hose of the distributor vacuum advance and the intake manifold port is tapped into the rear of the intake manifold by rubber hose.

When the engine is operating at slow idle speed, the compressor will not operate due to insufficient vacuum available to open the vacuum relay valve. See Figure 9F-11. As engine RPM is increased to fast idle or to cruising speed, the increased engine

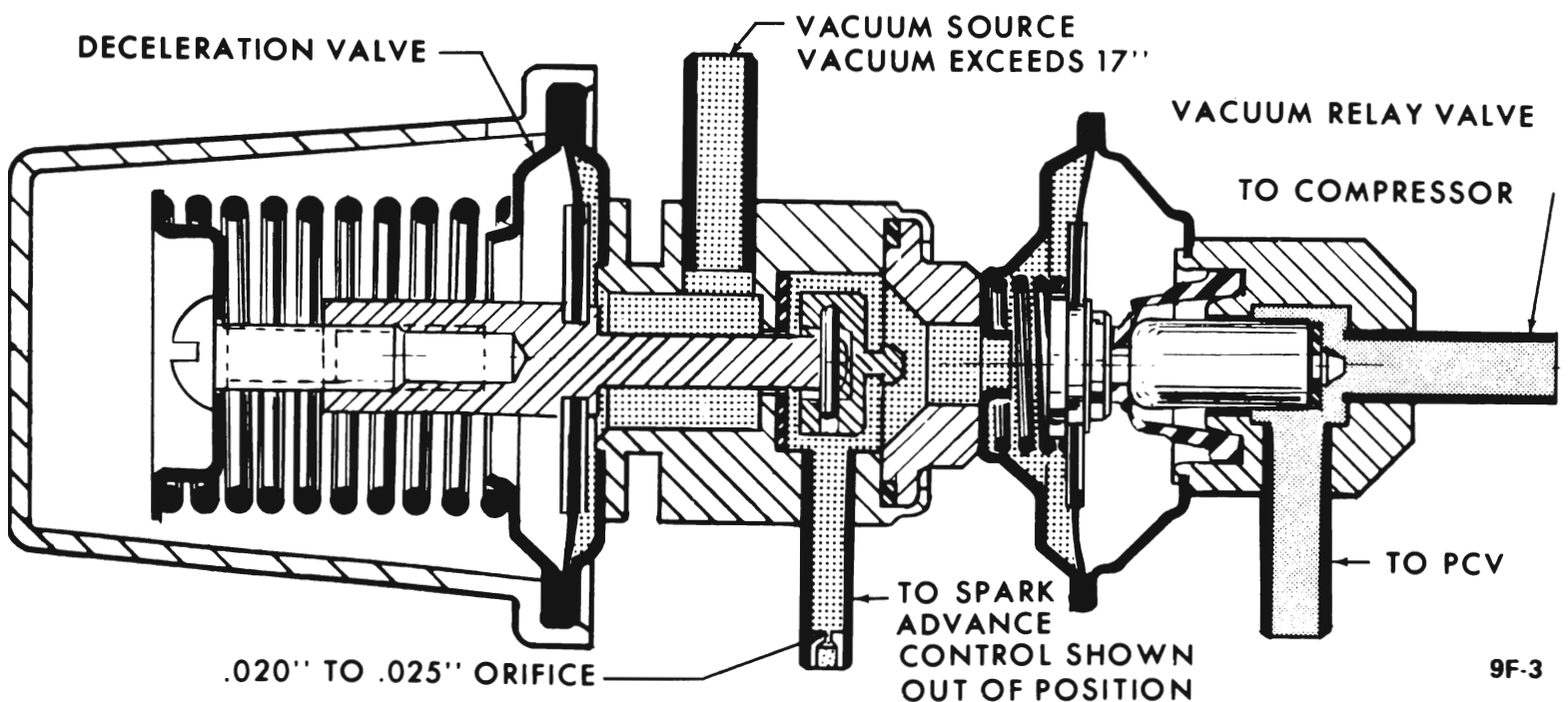

Figure 9F-3 - Deceleration Condition - Both the Deceleration Valve and the Vacuum Relay Valve are OPEN

vacuum is metered through a .020" to .025" restriction (orifice) located in the spark advance port of the vacuum regulator valve. See Figure 9F-2.

This increased vacuum overcomes the relay valve spring tension causing the relay valve to open and allows the compressor to operate on vacuum from the positive crankcase ventilation system.

To help maintain compressor output, it is necessary to provide vacuum to the compressor during deceleration conditions. This is accomplished through the connection of the deceleration valve vacuum port to the vacuum source. See Figure 9F-3.

During deceleration, vacuum at the rear of the intake manifold exceeds 17 inches and vacuum at the spark advance port is negligible. The manifold vacuum overcomes the deceleration valve spring tension and causes the deceleration valve to open permitting vacuum to overcome the relay valve spring tension and open the relay valve to admit P.C.V. vacuum which in turn operates the compressor. Since there is literally no vacuum to the spark advance port, the .020" to .025" restriction (orifice) in the spark port prevents vacuum feed back from advancing the spark in the ignition distributor.

The compressor is a two-stage, vacuum actuated type, requiring no lubrication. See Figure 9F-4. High pressure air is supplied to the reservoir tank by the second stage of the two-stage compressor. The first stage intake stroke draws air at atmospheric pressure through a one way check valve located in the end of the first stage housing under the first stage housing cover. See Figure 9F-5. On the first stage compression stroke, the intake valve is closed and the oneway check valve in the second stage end of the piston is opened. This allows the air from the first stage cylinder to flow through the hollow piston into the second stage cylinder for high pressure compression. See Figure 9F-6. The second stage compression stroke closes the check valve in the piston and opens the check valve in the end of the second stage housing. See Figure 9F-7.

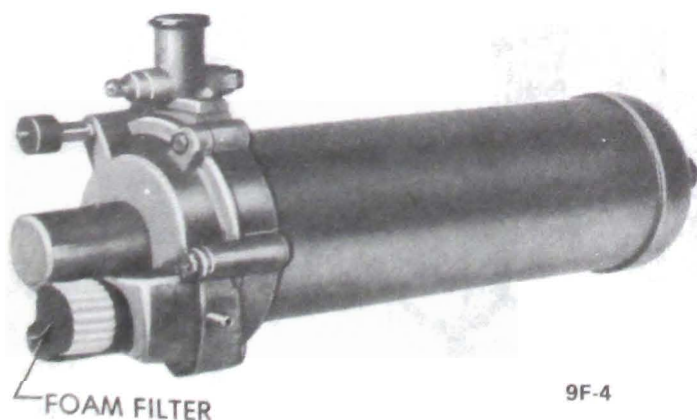

Figure 9F-4 - Compressor, Reservoir Tank and Regulator Valve Assembly

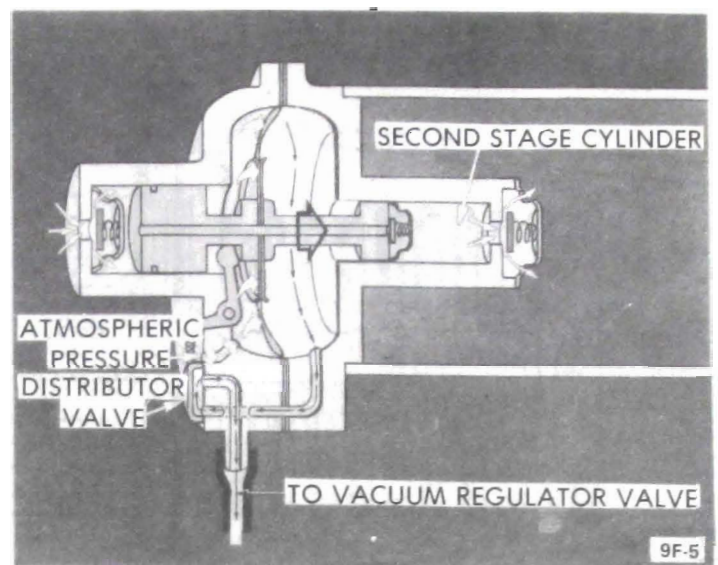

Figure 9F-5 - First Stage Intake Stroke

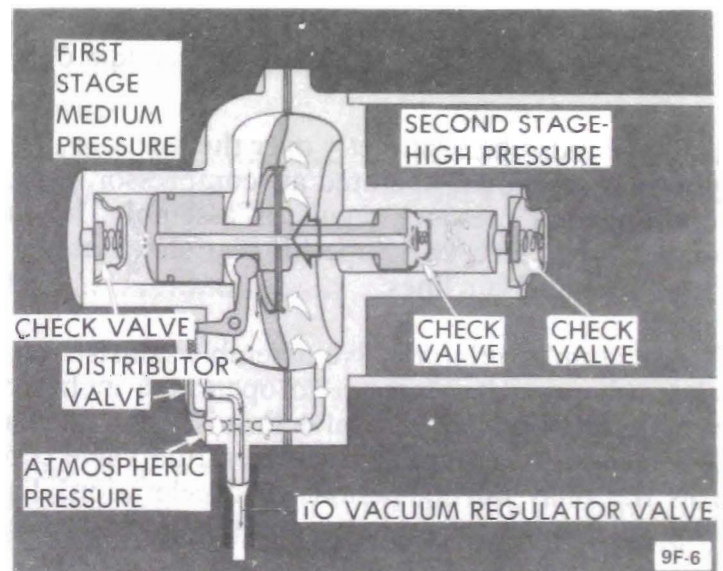

Figure 9F-6 - First Stage Compression Stroke

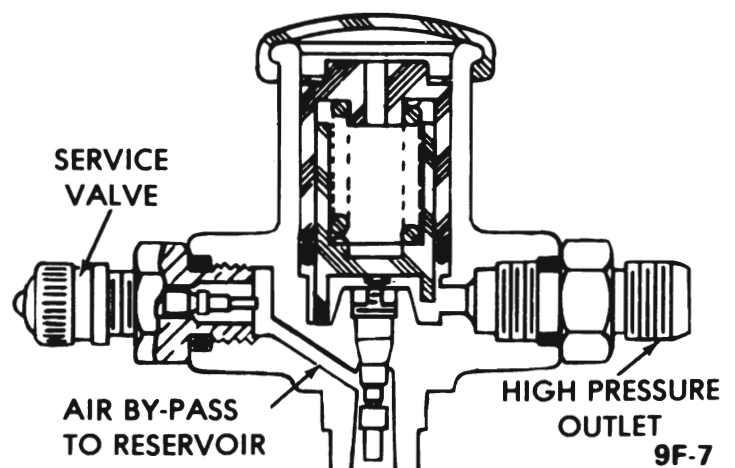

Figure 9F-7 - Second Stage Compression Stroke

The intake and compression strokes are controlled by a sliding distributor valve that is actuated through an arm that is tripped by the piston as it nears the end of each stroke. Each time the arm actuates the distributor valve, a different set of holes are covered in the first stage housing. The distributor valve controls the flow of intake manifold vacuum and air under atmospheric pressure, alternately to opposite sides of the compressor diaphragm. See Figures 9F-6 and 7.

As the compressor cycles, the reservoir air pressure gradually increases causing a back pressure on the second stage piston until it equals the push of pressure against the diaphragm. At this point, a balanced condition is reached and the unit stops operating. After reservoir pressure drops due to system air usage, the compressor again begins to cycle and replenish the reservoir.

Pressure balance will depend upon the prevailing manifold vacuum and atmospheric pressure. Both are affected by altitude above or below sea level. Balance pressure will vary from approximately 150 to 275 psi.

The pressure regulator valve is preset and limits the reservoir outlet pressure to approximately 125 psi to avoid damage to the height control valve and Superlift shocks. See Figure 9F-8.

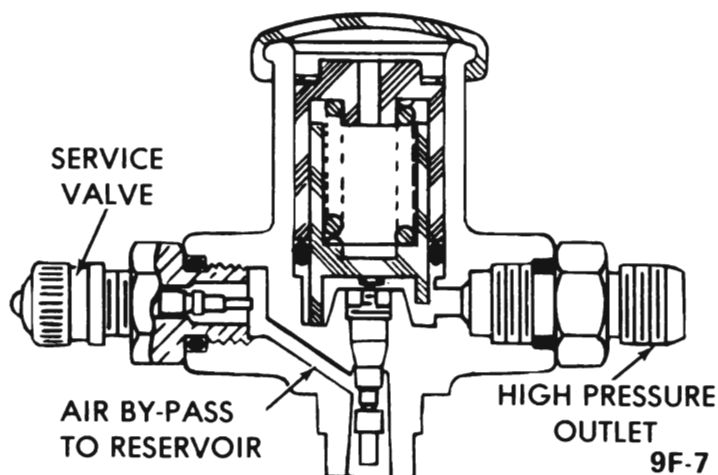

Figure 9F-8 - Pressure Regulator Valve

The height control valve, which is mounted on the frame, senses rear car height through a link attached to the rear upper control arm on all cars except Estate Wagons. Link is attached to axle assembly on Estate Wagons. When load is added to the car, the overtravel lever is forced up causing an internal lever to open the intake valve. See Figure 9F-9. When this valve is open, high pressure air is admitted to the Superlift shocks. As the car raises to level (depending upon position of load), the intake valve shuts off.

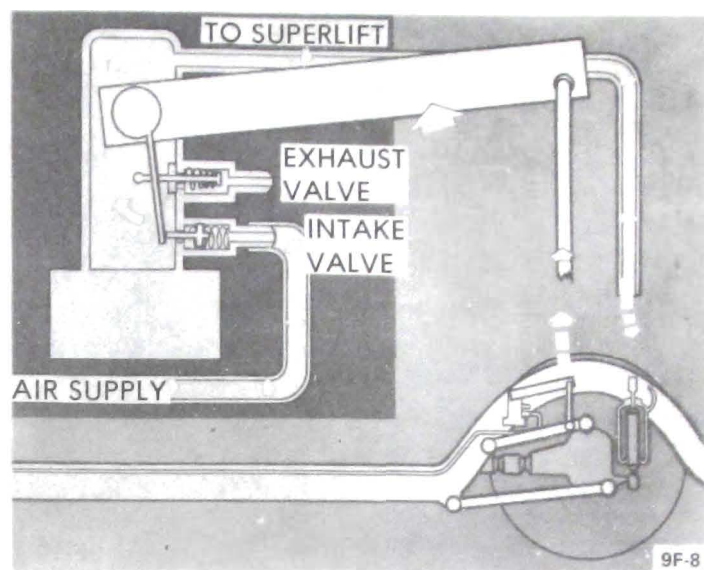

Figure 9F-9 - Load Added to Car

When load is removed from the car, the overtravel lever is forced down causing the internal arm to open the exhaust valve. As the car lowers to the level position (depending upon position of load), the exhaust valve shuts off. See Figure 9F-10.

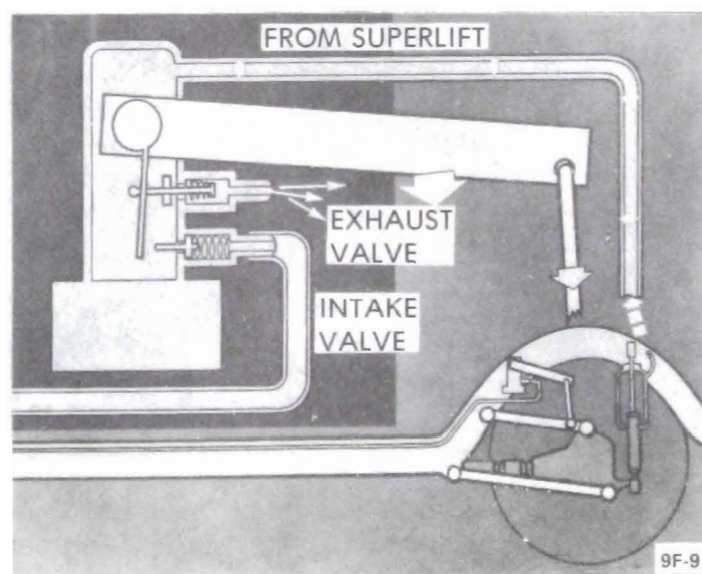

Figure 9F-10 - Load Removed From Car

A four to twenty-two second (at 70 degrees F.) time delay mechanism, which is built into the height control valve, prevents air transfer due to normal ride movements. The overtravel lever, which pivots around the control valve shaft, rides off the flat side of the control valve shaft and does not have time to react to the rapid changes or normal ride motions. See Figure 9F-11.

During changes due to loading, the time delay mechanism will allow the control valve shaft to open ei-

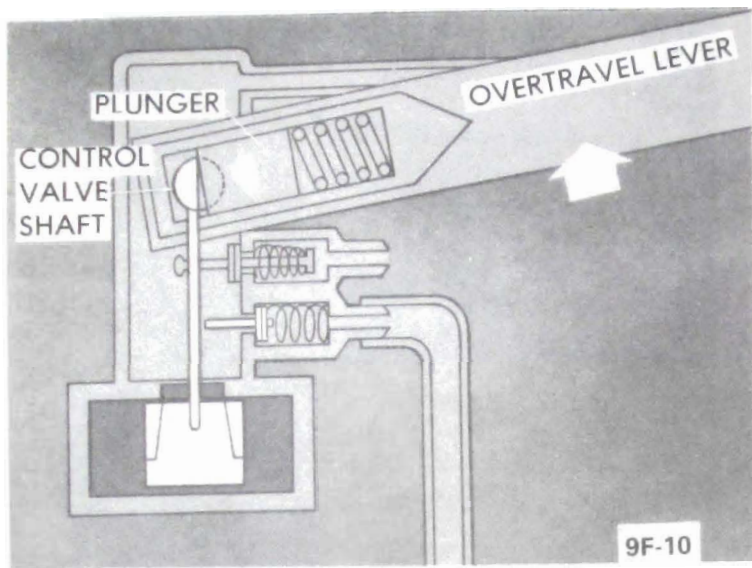

Figure 9F-11 - Rapid Movement of Overtravel Lever

ther the intake or exhaust valve as required, since this is not a rapid movement. See Figure 9F-12.

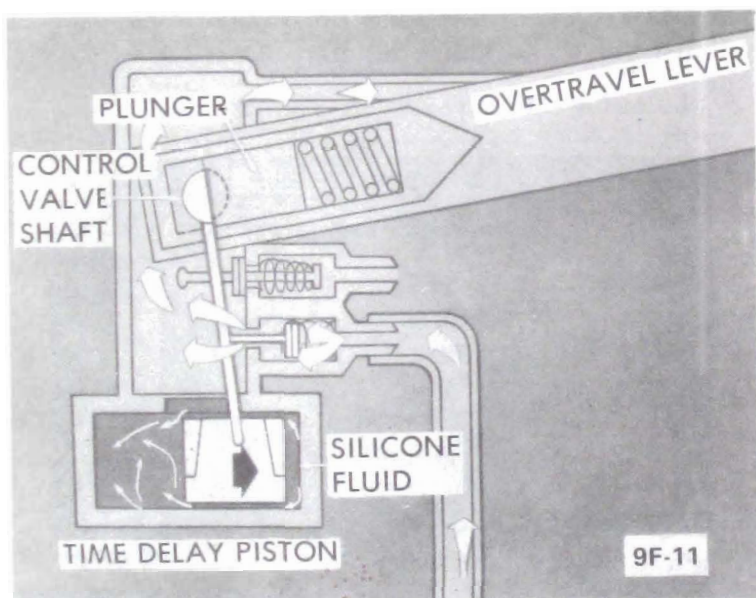

Figure 9F-12 - Load Movement of Overtravel Lever

The Superlift shock absorber is essentially a conventional hydraulic unit with a pliable nylon reinforced neoprene boot acting as an air chamber. See Figure 9F-13.

An eight to fifteen psi air pressure is maintained in the Superlift at all times to minimize boot friction. This is accomplished by a check valve in the exhaust fitting on the control valve. Neither shock absorber function nor conventional ride motions thru rear coil springs is impaired in the event of accidental air pressure loss.

Flexible air lines are used throughout the system. The line is 1/8 inch diameter tubing. Each fitting

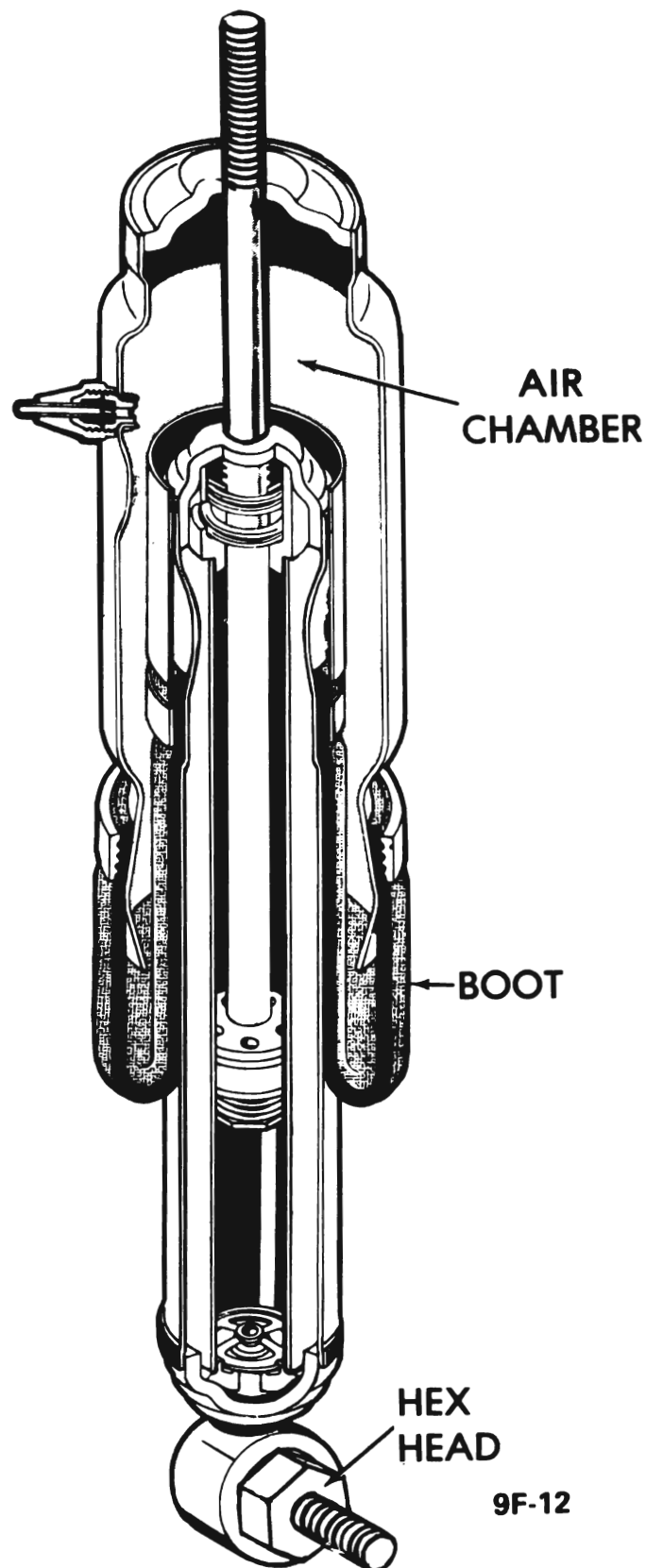

Figure 9F-13 - Superlift Shock Absorber - Sectional View

consists of a rubber seal, metal sleeve and nut. See Figure 9F-28. These parts are intended specifically for the 1/8 inch diameter line and must be used to effect a reliable seal.

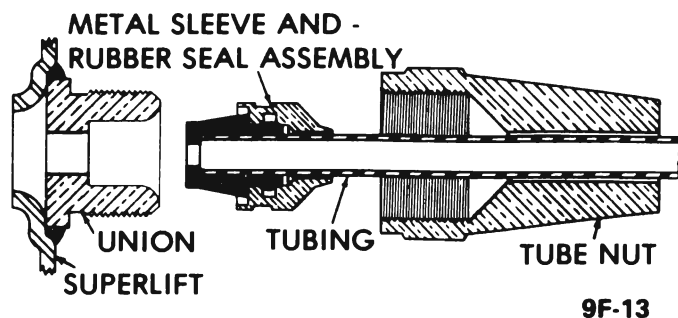

Figure 9F-14 - Fitting Nut and Seal

DIAGNOSIS

QUICK CHECK OF AUTOMATIC LEVEL CONTROL SYSTEM

Trim Height

1. Record rear trim height of car at curb weight (basic car with fuel tank full). Measure from ground to lower edge of rear wheel cutout.
2. Place 200 pounds of weight in trunk area of passenger cars or 180 lbs. on the tail gate of station wagons. Car should begin to level in 4-22 seconds at 70 degrees F. Final position should be no more than one inch lower than original dimension. If the dimension is more than one inch lower than original, jounce rear of car to neutralize rear suspension and recheck. If dimension is still more than one inch lower than original, adjust height control valve.
3. Remove weight. Car should begin to settle slowly in 4-22 seconds at 70 degrees F. Final position should vary no more than 1/2 inch from original dimension. If the dimension varies more than 1/2 inch from original, jounce rear of car to neutralize rear suspension and recheck. If variation still exists, adjust height control valve.

To properly service the automatic level control, it will be necessary to obtain Test Gage J-22124 or equivalent.

Vacuum Regulator Valve

Slow Engine Idle

The compressor should not operate during slow engine idle conditions. (V-8 engines with automatic transmission in drive and accessories turned off-600 RPM - V-8 engines with manual transmission in neutral and accessories turned off-700 RPM). If the compressor operates during slow engine idle, the problem could be improperly connected vacuum

links, improperly adjusted deceleration valve, misadjusted carburetor (intake manifold leak), or a relay valve leaking.

It can be determined whether or not the relay valve is leaking by first checking line routing, and then disconnecting and plugging hose from vacuum source (yellow hose). If compressor stops pumping, adjust deceleration valve.

The deceleration valve adjusting screw can be turned counterclockwise to lessen the spring tension on the valve which then requires less vacuum to open the valve. By turning the adjusting screw clockwise, more spring tension is applied on the valve, thus requiring greater vacuum for it to open.

To properly adjust the valve, turn the adjusting screw clockwise (if compressor is operating at slow idle) until the compressor stops. From this point, turn the adjusting screw 1/2 turn clockwise for final setting.

If compressor still functions at idle, disconnect carburetor advance hose (white hose). If compressor stops pumping, carburetor is misadjusted or there is a vacuum leak.

If compressor continues to pump, the relay valve is leaking and needs to be replaced.

Fast Idle

With the engine operating at fast idle (above 1000 RPM), the compressor should be in operation, unless balanced pressures exist in the system (150-275 psi). If a balanced pressure condition does exist, deflate the system until the compressor begins to operate. If the compressor fails to operate after being deflated, either the restriction (orifice) is plugged, a vacuum leak exists in the P.C.V. or compressor hose, or the relay valve is faulty.

(a) If there are no apparent vacuum leaks and the compressor still fails to operate, bypass the relay valve by removing the compressor and P.C.V. hose from the relay valve and connect them together. If the compressor starts to operate, the problem is in the relay valve, requiring the replacement of the vacuum regulator valve assembly.

(b) If the restriction is plugged, remove the spark advance port hose and use a piece of tag wire, or something similar, to dislodge the foreign material, accelerate the engine and let it decelerate, as this will cause the deceleration valve to open and allow manifold vacuum to remove the foreign material from the spark advance port.

Deceleration Condition

When the engine is operating in a deceleration condi-

tion, the compressor should be working if the system pressure is low. Deflate if necessary. Disconnect spark advance port hose and plug it. Cap or cover the spark advance port. With a vacuum gage installed in the manifold vacuum line, accelerate engine and let it decelerate. The deceleration valve should open at 18.3 inches of vacuum and thus actuate the relay valve which in turn permits the compressor to operate on P.C.V. vacuum. The deceleration valve can be adjusted if necessary by removing the protective cap and turning the adjusting screw clockwise to increase the amount of vacuum required to open the valve or counterclockwise to decrease the amount of vacuum required to open this valve. If the deceleration valve is faulty the vacuum regulator assembly must be replaced as a unit.

COMPRESSOR OUTPUT TEST - ON CAR

1. With all engine operated accessories turned off and ignition turned off, deflate system through service valve. Remove high pressure line at regulator and connect test gage.
2. Inflate reservoir to 70 psi through service valve.
3. Observe test gage for evidence of compressor air leak.
4. If leaking, proceed to leak test of the compressor, reservoir and regulator as outlined in paragraph 9F-15. If not leaking, continue with this test.
5. With engine running at 1000 RPM, observe reservoir pressure build-up for five minutes. Reservoir pressure should build up from 70 psi to a minimum of 90 psi.
6. If compressor fails to operate, by-pass the relay valve by connecting the P.C.V. hose to the compressor hose and repeat Step 5.
7. If compressor fails to cycle, make sure the vacuum line and filter are open and unobstructed before removing compressor for repair.
8. If build-up is too slow, proceed to repair compressor as outlined in MAINTENANCE AND ADJUSTMENTS section.
9. Satisfactory build-up indicates system problem to be in the control section. See "Pressure Regulator Test". However, again observe the test gage for evidence of an air leak and proceed accordingly.

PRESSURE REGULATOR TEST

Performance test the regulator with a known good compressor on the car.

1. Deflate system through service valve and discon-

nect line at pressure regulator valve. Install test gage on regulator valve high pressure fitting. See Figure 9F-15.

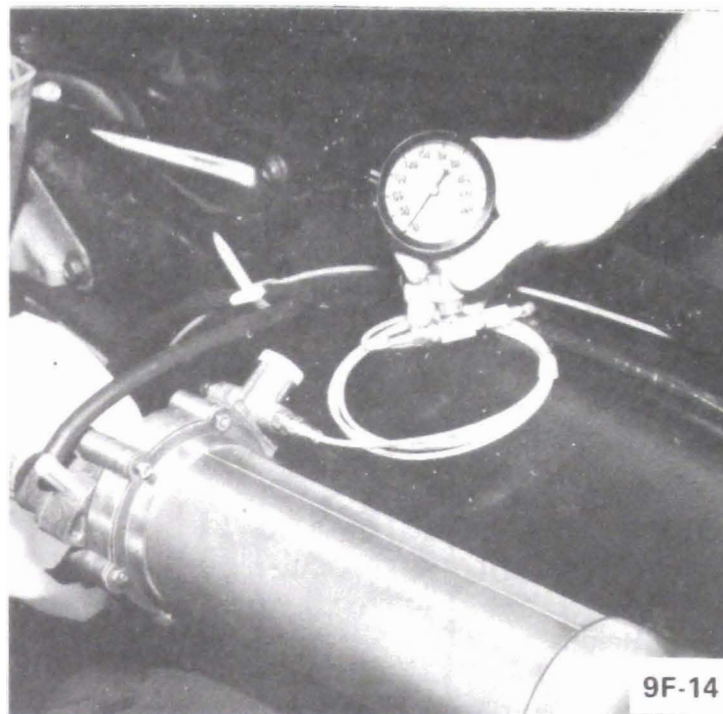

Figure 9F-15 - Test Gage Installed on Regulator Valve

2. Inflate system through service valve to maximum available pressure. See Figure 9F-8. If available pressure is less than 140 psi, start engine to build-up reservoir to this pressure.
3. Regulated pressure should build-up to and hold steady at 100-130 psi on test gage.
4. Check regulated pressure by momentarily (not more than one second) depressing valve core on test gage and observe gage reading.
5. If regulated pressure now reads less than 100 psi, replace regulator assembly.
6. If regulated pressure exceeds 130 psi, replace regulator assembly.

HEIGHT CONTROL VALVE TEST

Exhaust (Superlifts Inflated)

1. Disconnect overtravel lever from link.
2. Hold lever down in exhaust position until Superlifts slowly deflate. They should start to deflate within 22 seconds.
3. If Superlifts deflate, perform Intake Check.
4. If Superlifts do not deflate, remove exhaust adapter from control valve and hold lever down as

in Step 2. Replace adapter, "O" ring and filter if this deflates Superlifts.

5. Replace control valve if none of the above steps corrects problem.

Intake (Reservoir Pressure 125 psi Minimum)

1. Disconnect overtravel lever from link.
2. Hold lever up in intake position until Superlifts inflate. They should start to inflate within 22 seconds.
3. If Superlifts inflate and hold, proceed to Time Delay Check.
4. If Superlifts inflate and then leak down, perform leak test on lines and fittings and then on Superlifts, refer to "Height Control Valve Test". Also check and, if necessary, replace intake and Superlift screens and "O" rings. If Superlifts still do not inflate, perform leak test on valve, refer to "Leak Test". Repair as indicated and proceed to time-delay check.

Time Delay Check

1. Disconnect overtravel lever from link.
2. Disconnect lines at Superlift and intake ports.
3. Connect test gage to intake valve port and open air pressure (95 psi). Move overtravel lever approximately one inch down from neutral position as measured from end of lever.
4. Quickly move overtravel lever upward two inches; at the same time, begin timing number of seconds before air starts to escape from Superlift port. This delay should be from 4-22 seconds at 70 degrees F. Repeat check. This will check the air intake time delay. Proceed with check to determine air exhaust time delay.
5. Remove test gage and plug intake port with Fill Valve J-21999.
6. Connect test gage to Superlift port and open air pressure (95 psi). Move overtravel lever approximately one inch up from neutral position as measured from end of lever.
7. Quickly move overtravel lever downward two inches; at the same time, begin timing number of seconds until air begins to escape from exhaust port. This delay should be 4-22 seconds at 70 degrees F. Repeat check.

If either delay is not within specification, there has either been a loss of silicone fluid or valve has lost its

adjustment due to damage or wear. Valve must be replaced.

LEAK TEST

Lines and Fittings

1. Disconnect overtravel lever from link.
2. Hold lever up in intake position for maximum Superlift inflation and release.
3. Leak check all connections with a soap and water solution.

Superlifts

1. Disconnect lines and remove Superlift from car.
2. Inflate individually to 50-60 psi utilizing Fill Valves J-21999, submerge in water and observe for leaks.
3. Install Superlifts and connect lines.

Compressor, Reservoir and Regulator

1. Remove assembly intact.
2. Connect test gage to regulator. Inflate reservoir through service valve to 80-110 psi.
3. Route an 8" piece of rubber hose between vacuum and vent ports. See Figure 9F-16.

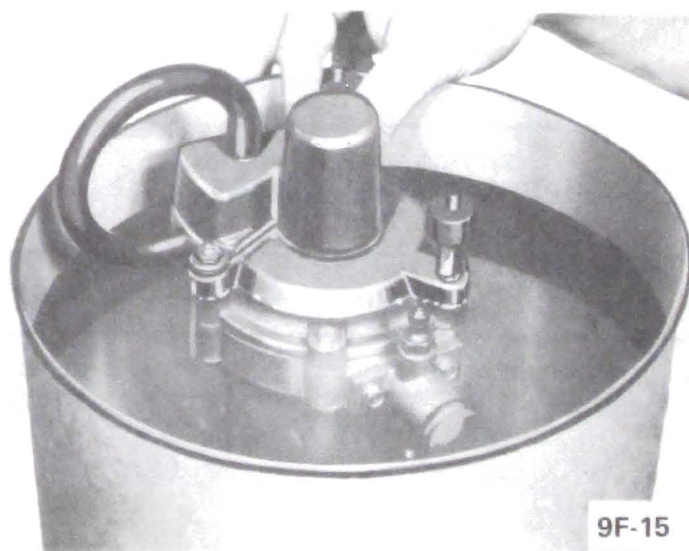

Figure 9F-16 - Checking Compressor, Reservoir Tank and Regulator for Leaks

4. While holding assembly in a vertical position with reservoir end down, immerse in water until diaphragm is just submerged. Do not submerge com-

pletely, as water can enter around the cover gasket. Observe for air leaks at:

Reservoir weld seam.

Reservoir to compressor "O" ring. A stream of bubbles may appear in this area and then cease. The bubbles are caused by atmospheric air being purged from air pockets in the second stage housing. If the bubbles stop, there is no leak.

Regulator to compressor "O" ring.

Regulator boot-defective internal "O" ring.

Diaphragm between first and second stage housings - tightening through-bolts may correct the leak.

Service valve.

Test gauge connections.

5. Remove hose from vacuum port and submerge disconnected end in water. Cover vacuum port with finger. Do not permit water to enter through vacuum port. If bubbles are evident, the probable cause is defective second stage housing check valve.

6. Correct any leaks by either tightening screws or replacing parts.

7. If the cover gasket area is inadvertently submerged, remove cover and tilt unit so that water may drain through openings by distributor valve mechanism. Move distributor valve from side to side until all water is purged. Blow dry with compressed air, both the distributor valve mechanism and interior of the cover. Replace cover.

If the compressor passes this test, yet fails the output test, the compressor, reservoir and regulator need to be overhauled.

Control Valve

1. Remove control valve from car.
2. Clean exterior of control valve thoroughly.
3. Connect test gage and air pressure source to intake adapter and open air pressure (80-110 psi).
4. Submerge unit in water. No air should escape if overtravel lever is in "neutral" position. If bubbles escape from Superlift port, replace control valve.
5. Shut off air pressure and detach test gage from air intake port. Plug intake port with Fill Valve, J-21999.
6. Connect test gage to Superlift port and open air pressure.
7. With overtravel lever in "neutral" position, no air should escape. If bubbles escape from exhaust port, replace control valve.
8. If air escapes around edge of cover plate, the gasket must be replaced.
9. Remove control valve from water. Actuate overtravel lever to expel any water from unit.
10. Shut off air pressure and remove line from Superlift port.

TROUBLE DIAGNOSIS CHART

Condition	Possible Cause	Correction
Car loaded, will not raise.	1. External damage or breakage.	1. Visually inspect: a. Lines b. Link c. Control valve d. Superlifts
	2. Line leak.	2. Leak test - lines and fittings.
	3. Control valve setting incorrect.	3. Perform trim adjustment on car.
	4. Defective component.	4. Perform system test and proceed as indicated.

Condition	Possible Cause	Correction
Car loaded. Raises to level and then leaks down.	1. Line leak.	1. Leak test lines and fittings from control valve to superlifts and crossover line.
	2. Control valve exhaust leak.	2. Control valve test - on car.
	3. Superlift leak.	3. Leak test superlifts.
	4. Control valve leak.	4. Leak test - control valve off car.
Car loaded, raises partially.	1. Load excessive (over 500 lbs. at axle) on cars with special springs.	1. Distribute load, shift forward if practical.
	2. Control valve setting incorrect.	2. Perform trim adjustment on car.
	3. Low supply pressure.	3. Perform compressor output test on car.
Car unloaded, rides too high, will not come down.	1. Control valve setting incorrect.	1. Perform trim adjustment on car.
	2. External damage or breakage.	2. Visually inspect: a. Lines b. Link c. Control valve d. Superlifts
	3. Defective control valve.	3. Control valve test.
	4. Supply line and superlift line reversed.	4. Install lines in correct locations.
Car rises when loaded but leaks down while driving.	1. Time delay mechanism not functioning properly.	1. Check time delay mechanism.
Compressor will not operate during fast idle cruising speeds (low system pressure).	1. Plugged restriction orifice.	1. Clean restriction orifice.
	2. Defective relay valve.	2. Replace vacuum regulator valve assembly.
	3. Vacuum leak.	3. Inspect for and correct.
	4. Faulty compressor.	4. Correct as necessary.

Condition	Possible Cause	Correction
Compressor operates at slow idle speed (low system pressure).	1. Defective relay valve. Intake manifold leak.	1. Replace vacuum regulator valve assembly.
	2. Improper deceleration valve spring adjustment.	2. Readjust deceleration valve spring screw.
	3. Excessive spark port vacuum.	3. Check out engine vacuum.
Compressor will not operate during deceleration period (low system pressure).	1. Defective deceleration valve.	1. Replace vacuum regulator valve assembly.
	2. Improper valve spring adjustment.	2. Readjust decelerator valve spring screw.
	3. Vacuum leak.	3. Inspect for and correct.
	4. Faulty compressor.	4. Correct as necessary.

ON CAR DIAGNOSTIC PROCEDURE

TROUBLE CHART

TROUBLE CONDITION	START WITH STEP
CAR LOADED, WILL NOT RAISE CAR SITS LOW	1
CAR LOADED, RAISES PARTIALLY	1
CAR LOADED, RAISES TO LEVEL THEN LEAKS DOWN	6
CAR UNLOADED, RIDES TOO HIGH IN REAR	13 B and E
COMPRESSOR CYCLES CONTINUOUSLY	5
EXTREMELY SLOW LEAK—OVER NIGHT LEAK DOWN DURING COLD WEATHER	11

STEP 1 – Check compressor tank pressure, refer to figure 1 for location of service valve on compressor.

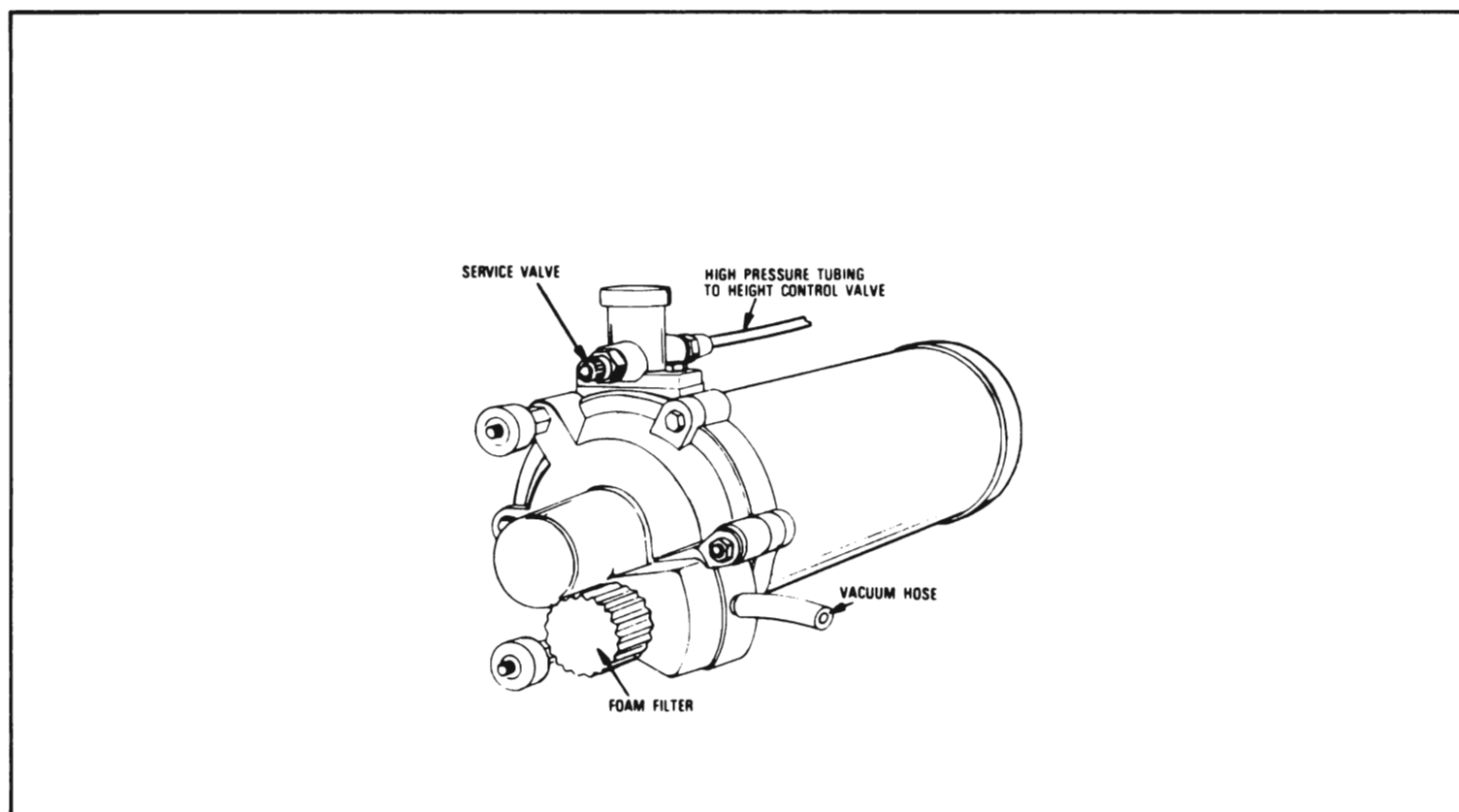
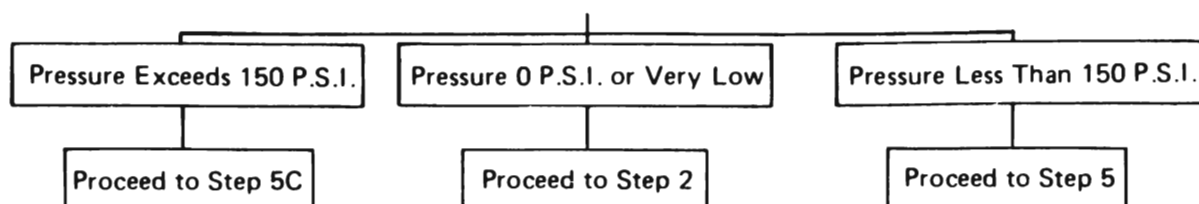
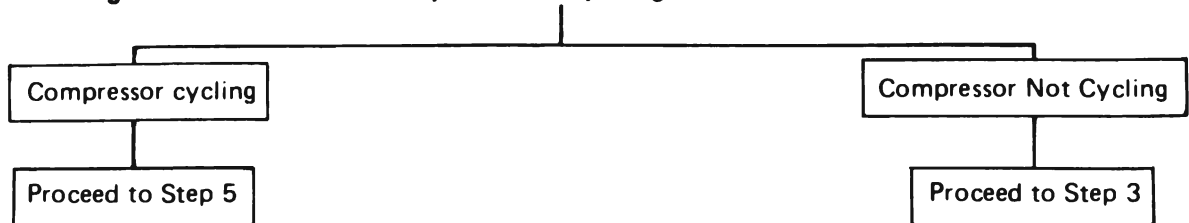

FIGURE 1—CHECKING TANK PRESSURE



STEP 2 – Start engine and observe if compressor is cycling.



STEP 3 – Refer to Figure 2. Remove foam filter and observe if compressor cycles.

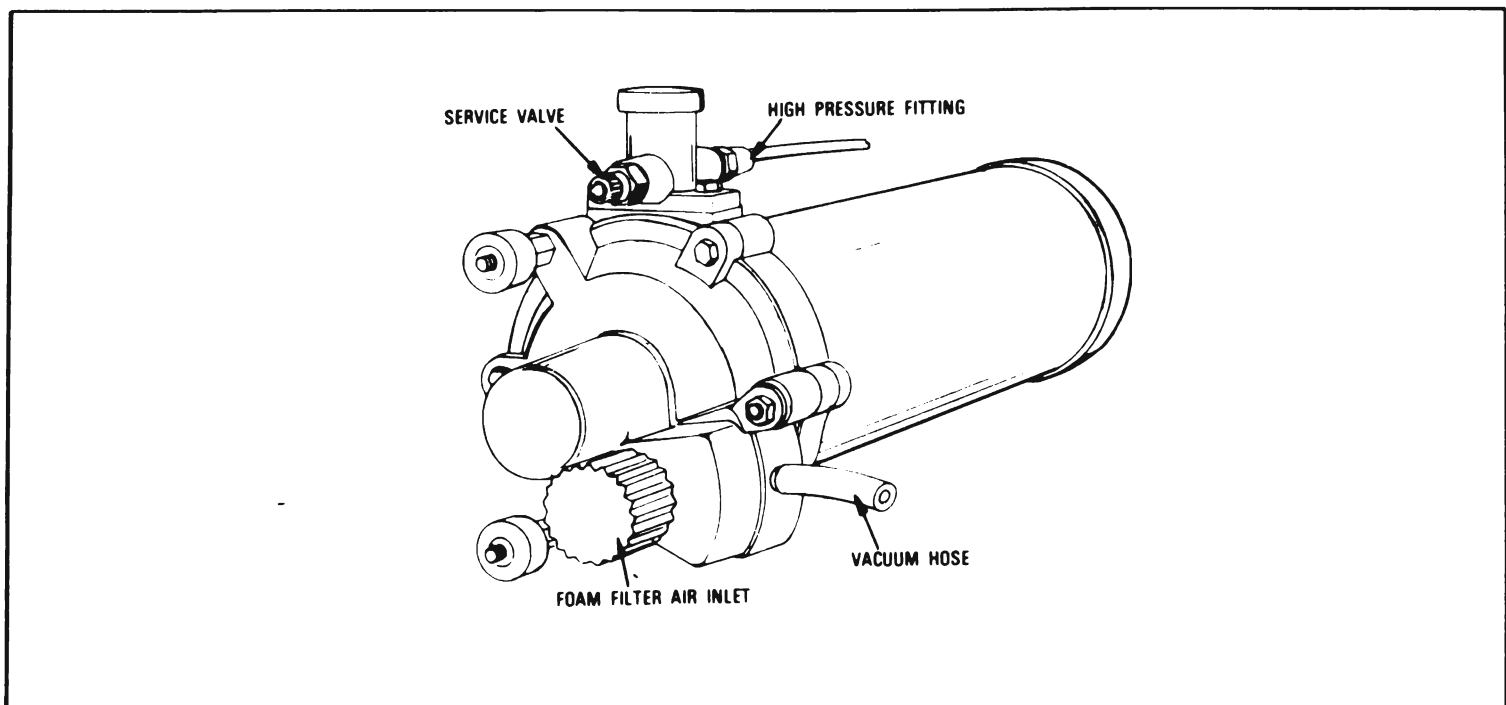
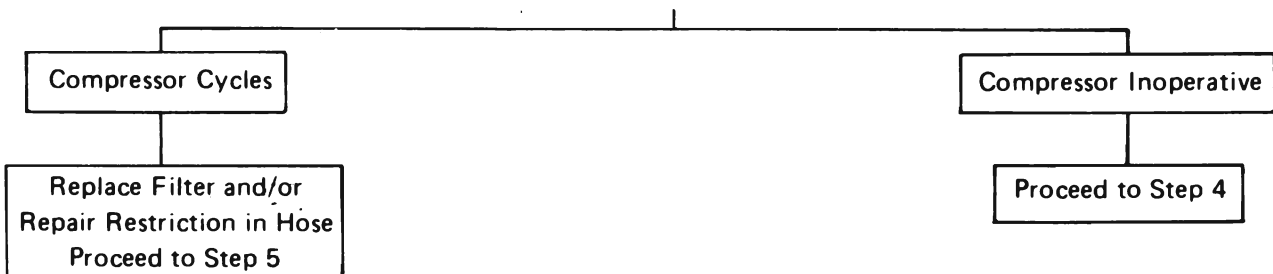
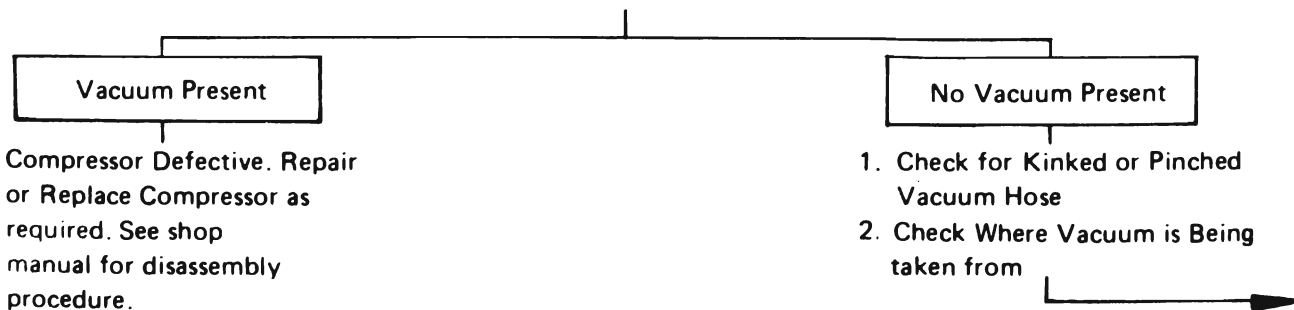

FIGURE 2—CHECKING VACUUM SUPPLY TO COMPRESSOR



STEP 4 – With engine running, remove vacuum hose from compressor vacuum port, Figure 2, and check for vacuum at end of hose.



Make necessary corrections and recheck compressor operation

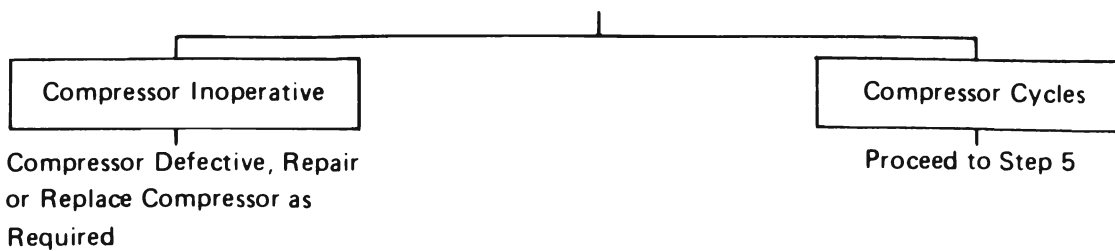

STEP 5 – A. Disconnect high pressure line at compressor regulator and attach gauge (J-22124) to compressor regulator fitting. Refer to Figure 3.

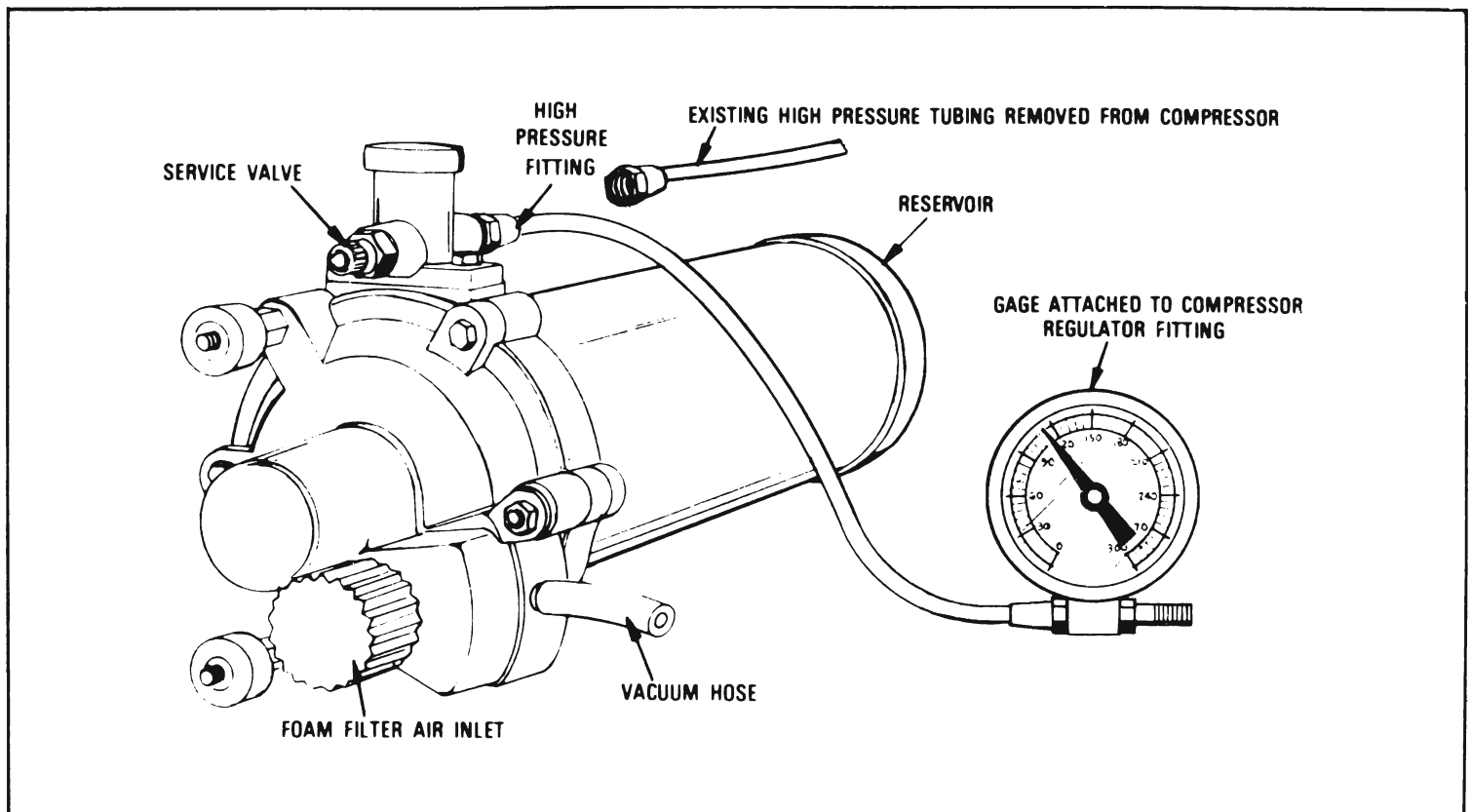
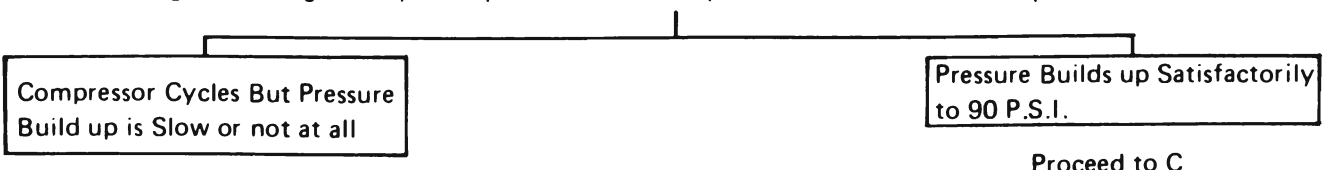

FIGURE 3—ATTACHING GAGE TO COMPRESSOR HIGH PRESSURE FITTING

B. Perform compressor output test.

1. Fill compressor reservoir to 70 PSI through service fill valve. Refer to Figure 3. Observe test gauge for evidence of air leak.
2. With engine running at idle, allow pressure to build up for 5 minutes. Reservoir pressure should reach 90 psi.



If pressure build up is slow, recheck that vacuum hose, filter or air inlet hose have no restriction. If vacuum hose, filter or air inlet hose show no restriction, remove compressor from vehicle and repair or replace it as required.

C. Perform regulator test.

1. Allow engine to continue to run at idle speed. Pressure should level off between 115-130 P.S.I. when checked on regulated side of regulator. Refer to Figure 3.

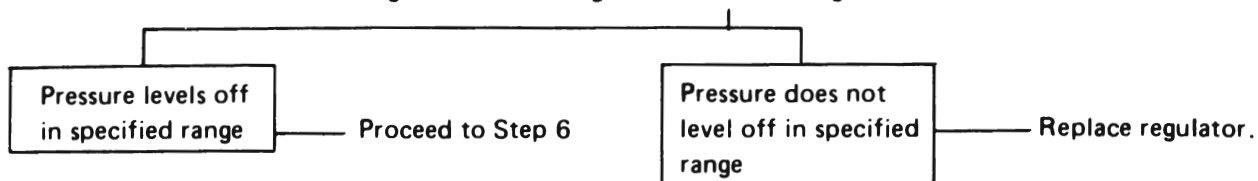

STEP 6 – Check system operation independent of compressor as follows:

- A. Connect test gauge (J-22124) to high pressure line that attaches to compressor regulator. Figure 4.
- B. Record rear trim height of unloaded vehicle at curb weight. (Basic car with full tank of gas).
- C. Add approximately 250-300# to passenger car trunk. (Two people or equivalent weight. 3 people for station wagon.)

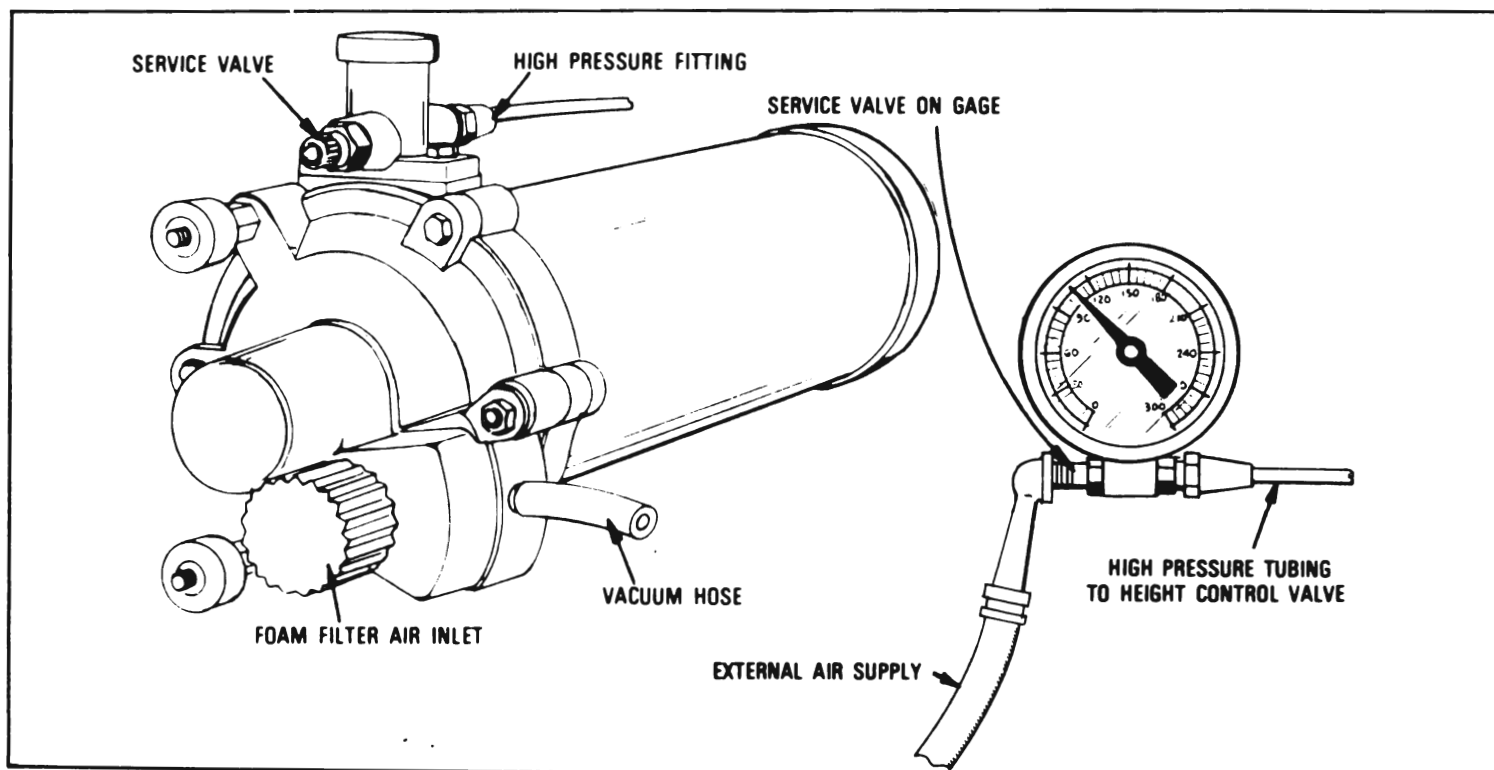
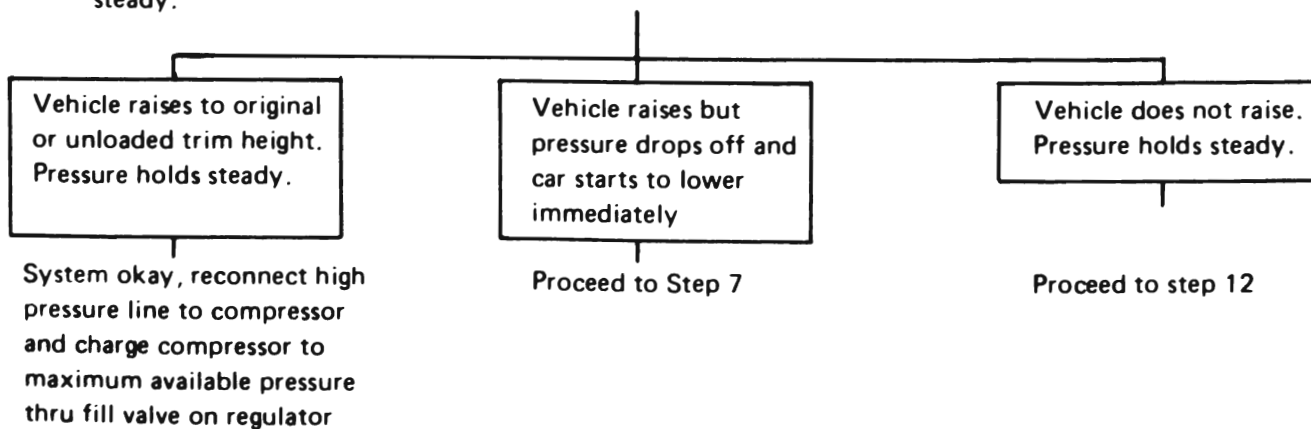

FIGURE 4—CHECKING SYSTEM OPERATION WITHOUT COMPRESSOR

- D. With external compressed air supply, charge system to a maximum of 125 psi (if available) thru the gage fill valve. If vehicle returns to unloaded trim height, $\pm\frac{1}{2}$ " measured in Step B, also observe if pressure holds steady.



STEP 7 – Check for leaks in high pressure line between compressor regulator and height control valve.

- A. Remove gauge from high pressure line at compressor end and install plug J-21999 shown in Figure 5. Position it so it will be accessible when vehicle is lifted on hoist.
NOTE: Be sure valve in J-21999 does not leak.
- B. Raise vehicle on hoist, disconnect high pressure line from height control valve and install gauge J-22124 to high pressure line. Refer to Figure 7 for location of height control valve high pressure fitting.
- C. Using external air supply, charge high pressure line to 100 psi thru the gauge fitting and observe if pressure holds steady or drops off.

Pressure holds steady

Reconnect high pressure line to height control valve and proceed to step 8.

Pressure drops off

Replace or repair line as required. Note: Check that inserts on plastic line fittings are properly installed.

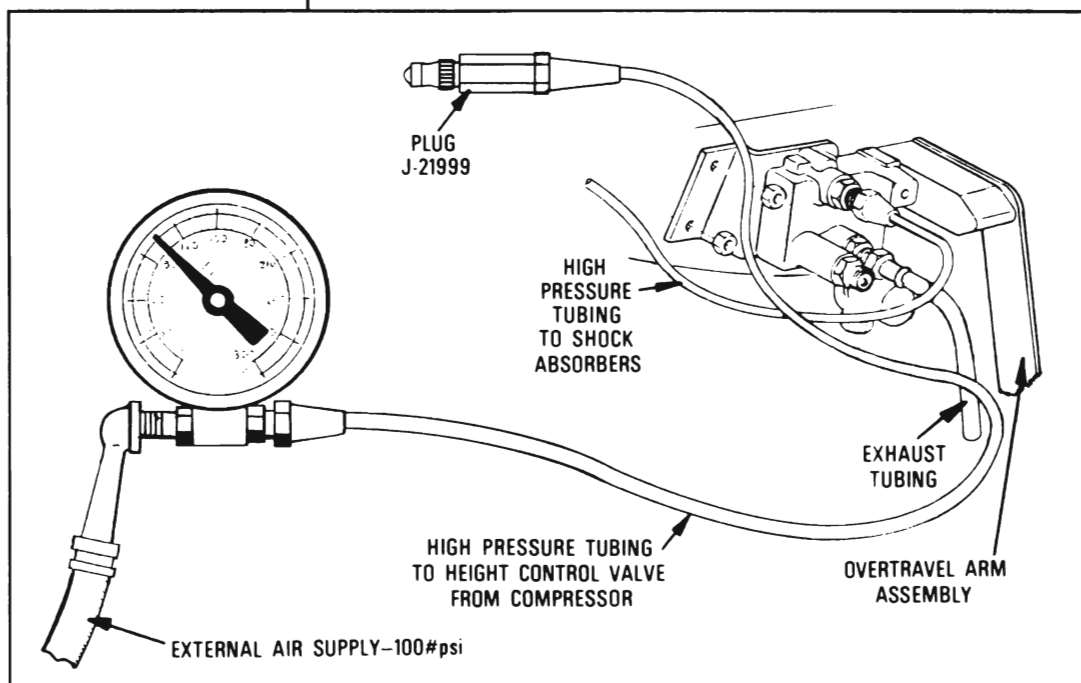

FIGURE 5—CHECKING FOR LEAKS

Recheck system per step 6.

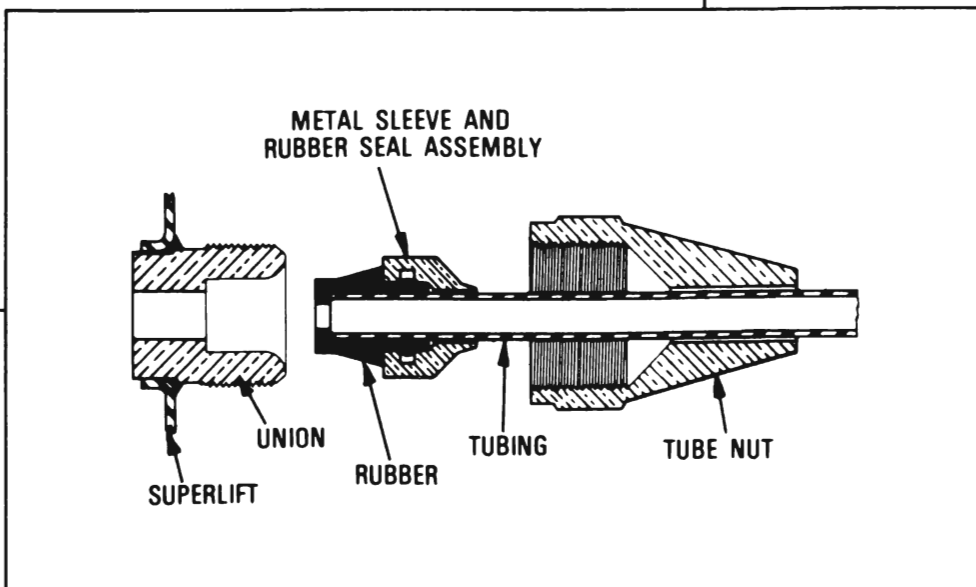

FIGURE 6—CHECKING FITTINGS

STEP 8 – Inspect tubing and fittings from height control valve to shocks as follows:

- A. Check for loose or improperly assembled fittings at shocks and/or height control valve. Figure 6.
- B. Check for possible contact of plastic tubing with exhaust system.

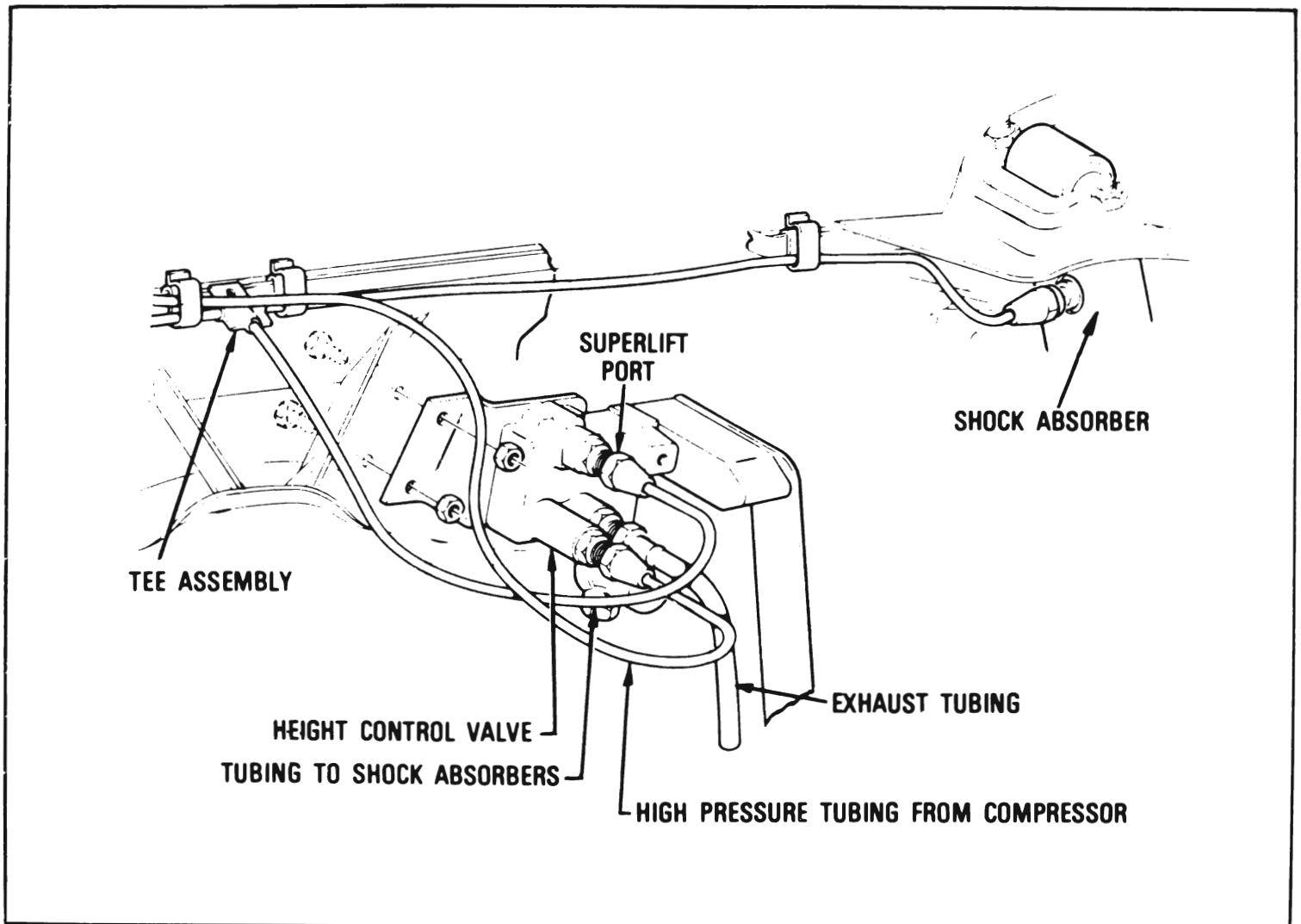
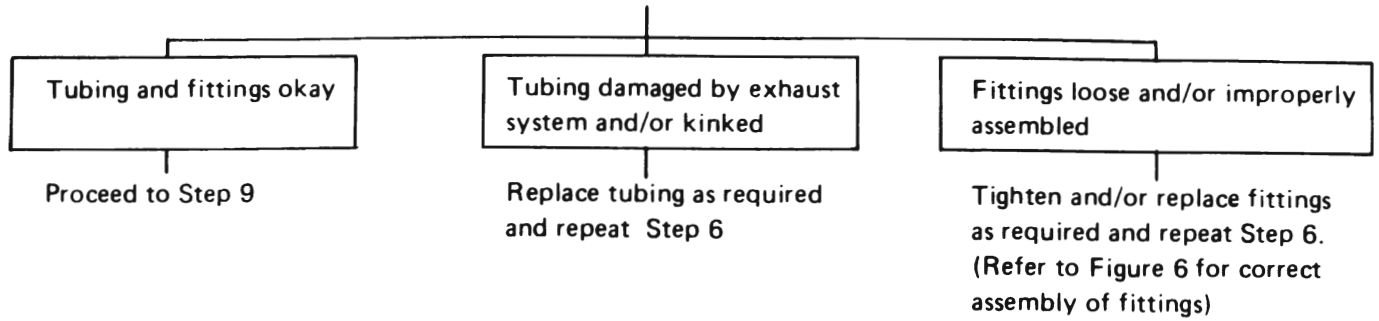
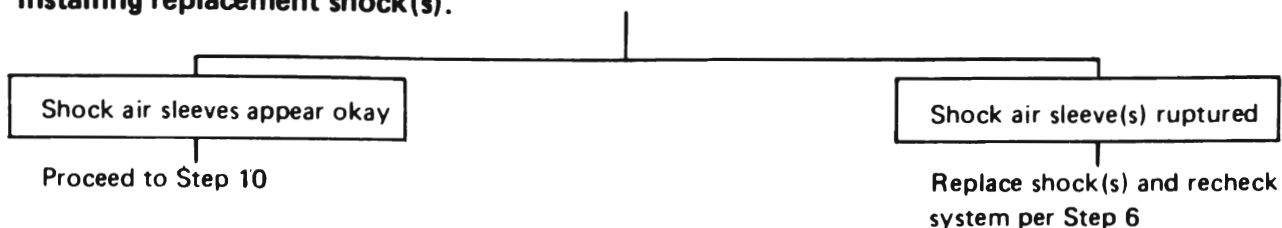

FIGURE 7—INSPECTING HEIGHT CONTROL VALVE

STEP 9 – Inspect each shock visually as follows:

Inspect each shock absorber rubber air sleeve for a rupture condition. **NOTE:** If rupture appears to be caused by rubbing or interference condition, be sure to correct this condition when installing replacement shock(s).



STEP 10 – Disconnect shock absorber air supply tubing from height control valve and attach gauge J-22124 to tubing. Using an external air supply, inflate shocks to 100 p.s.i. and observe if pressure holds steady or drops off. Refer to Figure 8. NOTE: Soap suds may be used to help locate leak condition.

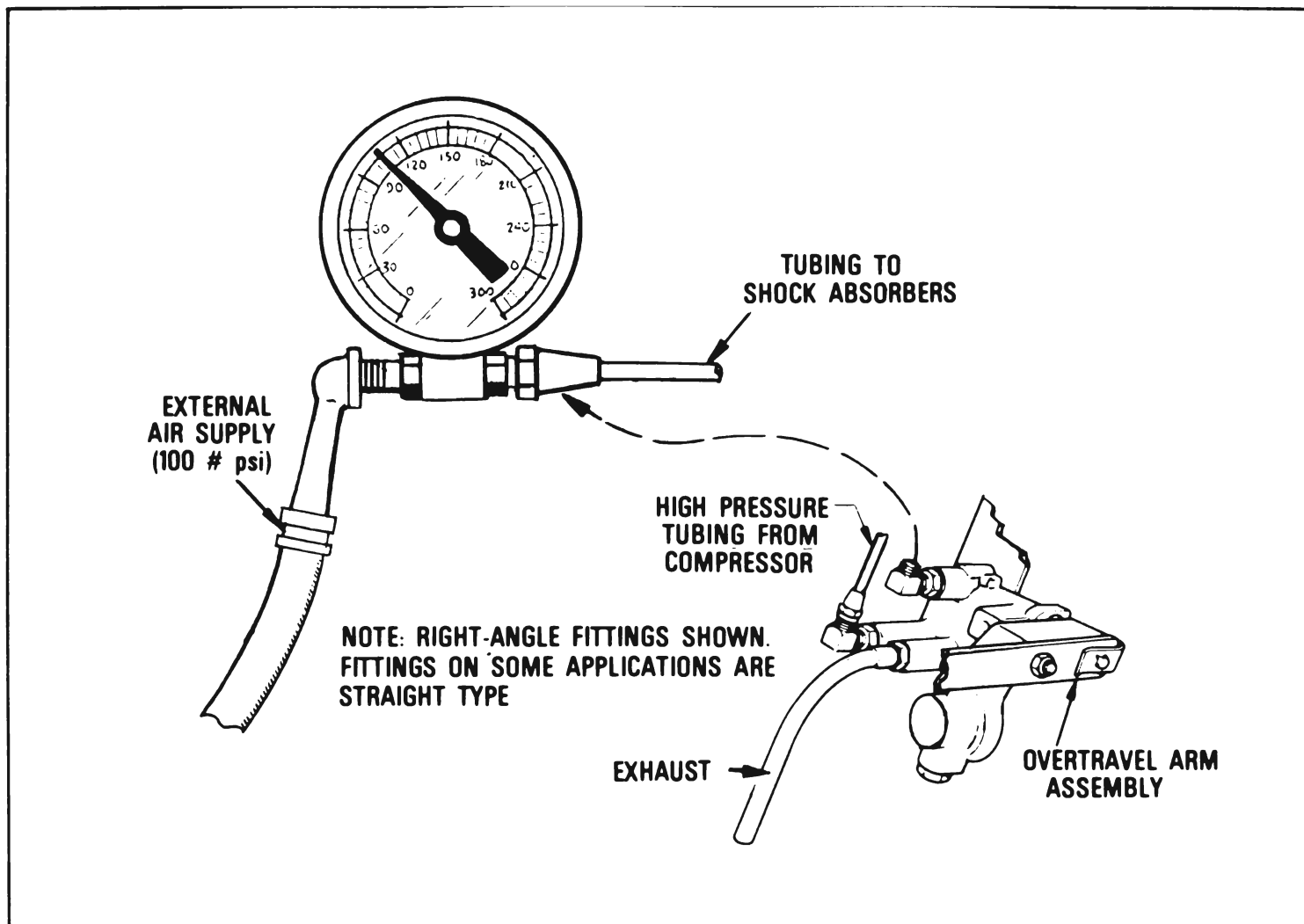
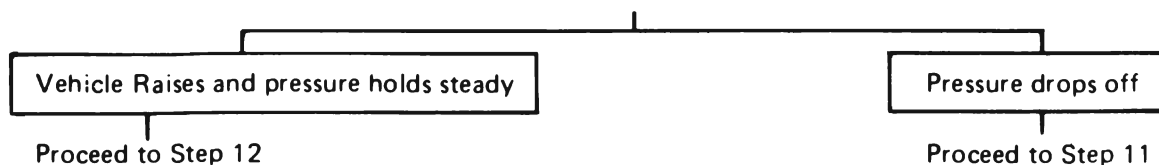
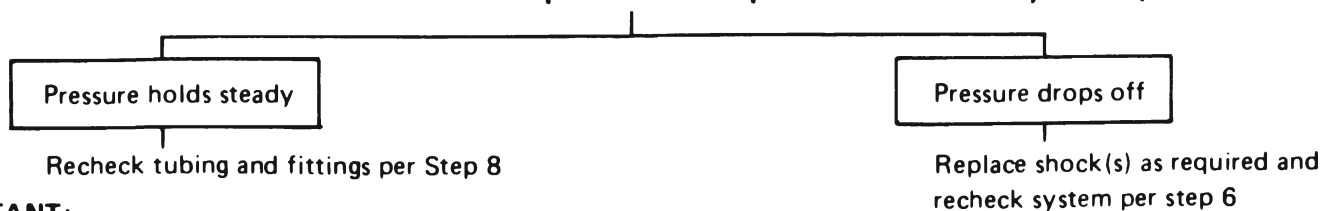

FIGURE 8—CHECKING OUT HEIGHT CONTROL VALVE



STEP 11 – Check each shock separately for leaks as follows: Connect test gauge J-22124 individually to each shock and inflate shock to 100 psi. Observe if pressure holds steady or drops off.



IMPORTANT:

If extremely slow leak down condition occurs only during cold weather, one or both shocks may be the cause. To duplicate this type of leak condition requires that the shocks be as cold as the surrounding ambient temperature. By the time an owner drives to the service account or dealer the shocks develop heat and the leak usually disappears. A method to determine which shock or if both are leaking follows:

- Attach a test gauge to each shock and inflate to 100 p.s.i.
- Position or attach gauges so that they may be read without the vehicle on a hoist.
- Move vehicle outside and recheck gauges periodically. NOTE: Pressure will decrease with temperature and gage will show this when vehicle is moved outside.

STEP 12 – Preliminary check of height control valve and attaching parts. Refer to Figure 9.

- A. Check that link which attaches the height control valve over-travel arm to the vehicle's rear suspension component is properly installed in the correct over-travel arm hole. Check that attaching nut is secure.
- B. Check that height control valve over-travel arm adjusting nut is tight.

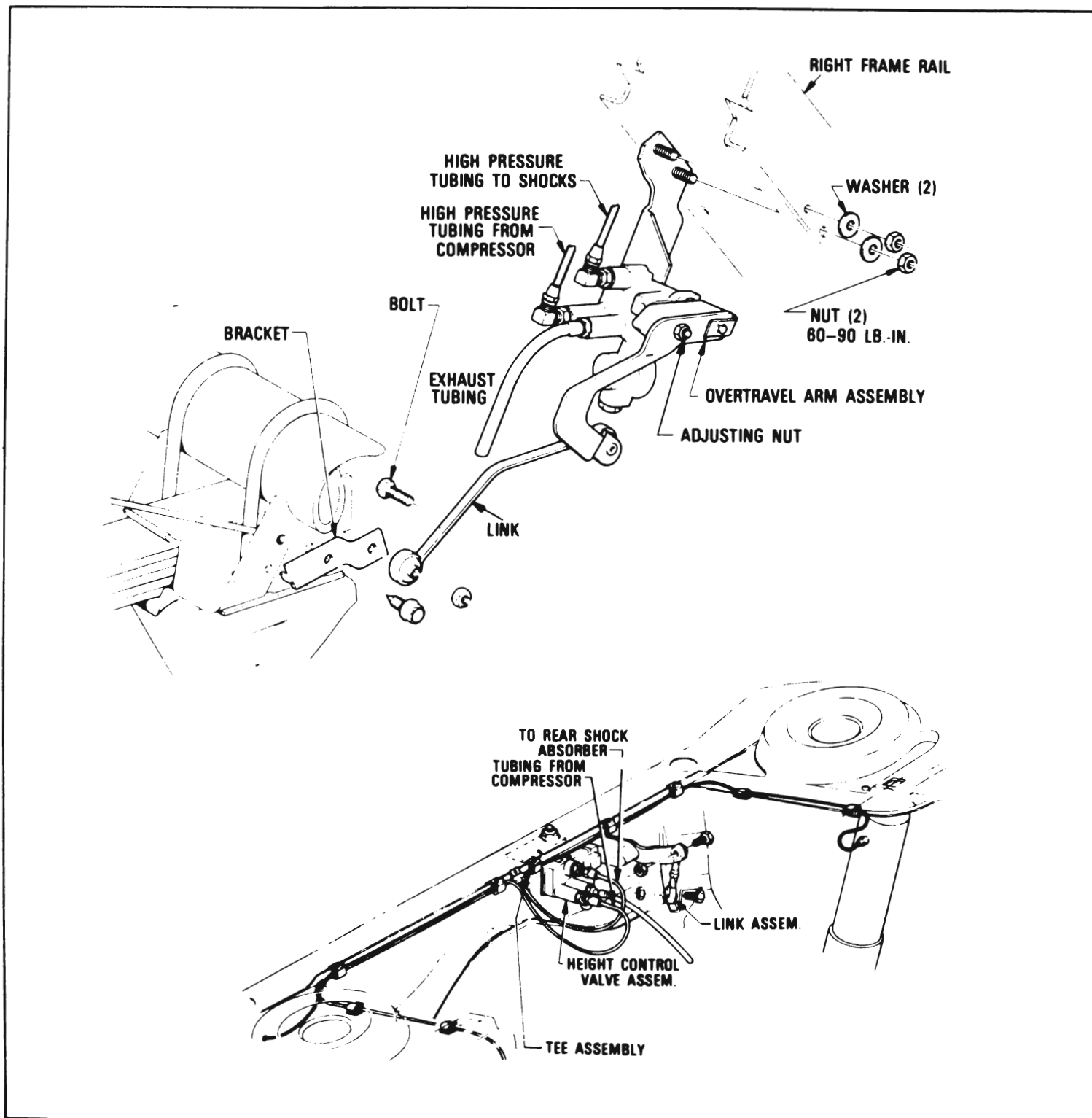
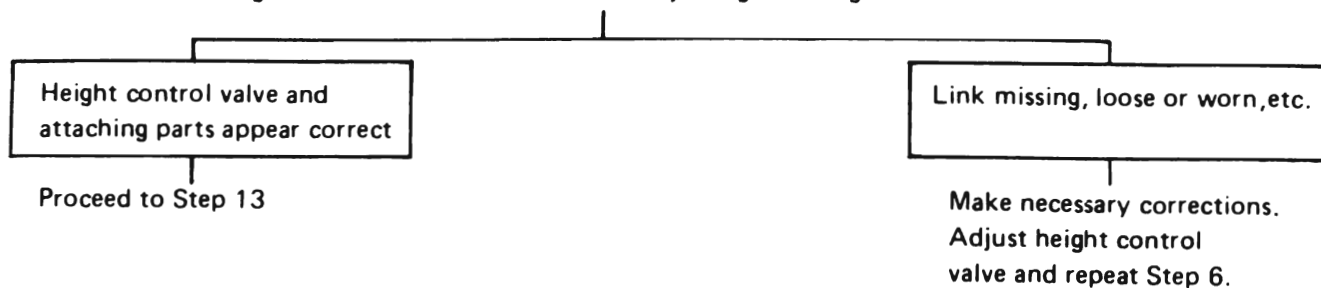

FIGURE 9—CHECKING ATTACHING PARTS TO HEIGHT CONTROL VALVE

STEP 13 – Check operation of height control valve as follows:

- A. Reconnect tubing from height control valve to shocks
- B. Disconnect link from height control valve over-travel arm, refer to figure 9 for typical link.
- C. Connect test gauge J-22124 to height control valve intake port. Figure 10.

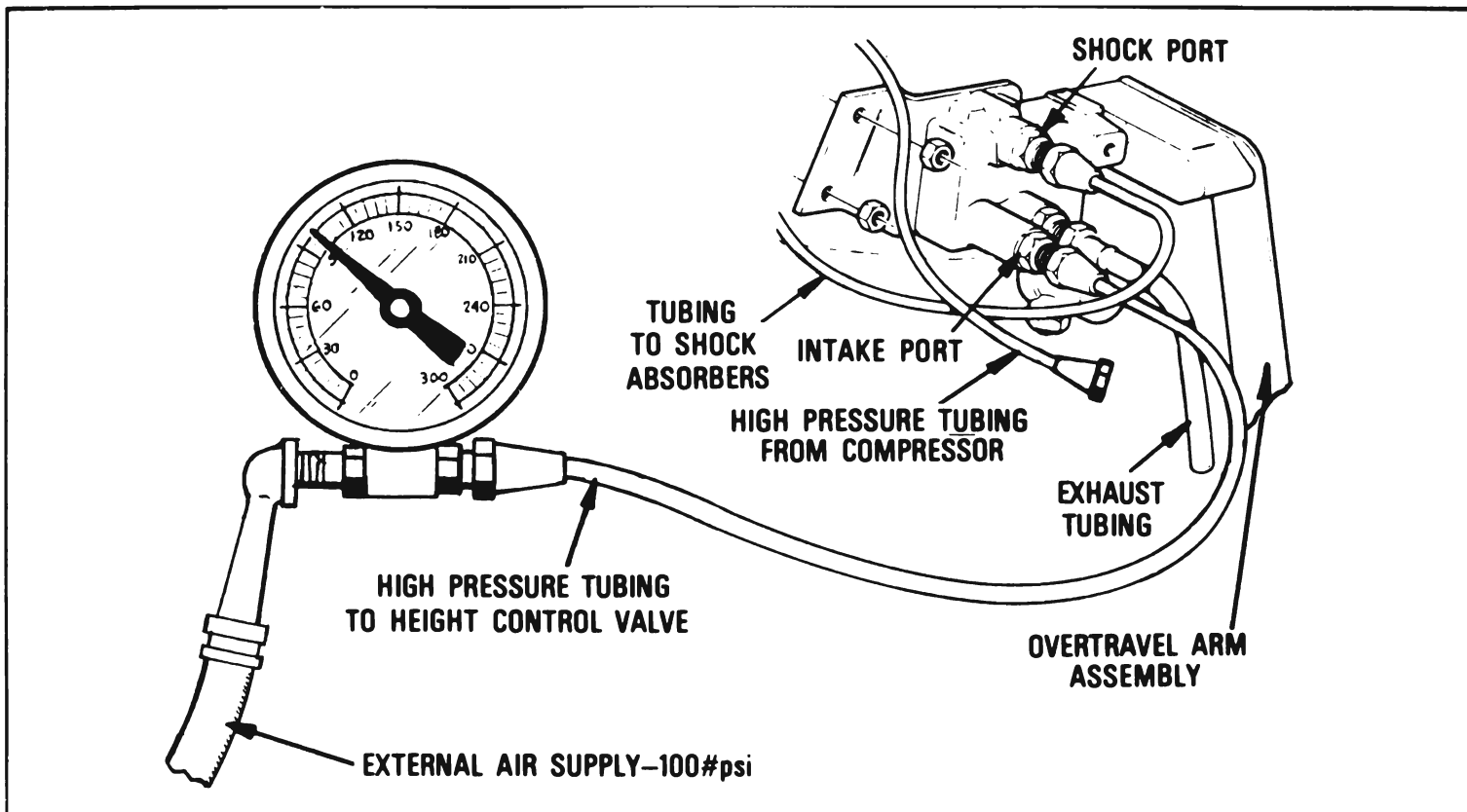
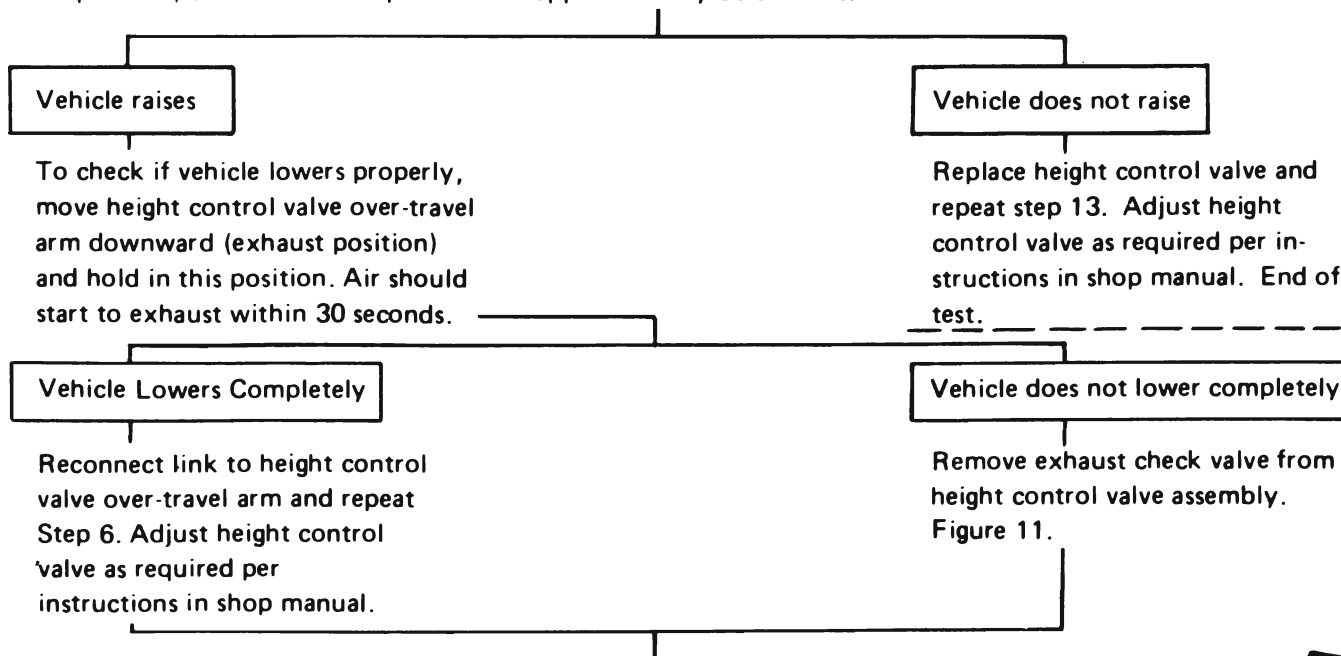

FIGURE 10—CHECKING OPERATION OF HEIGHT CONTROL VALVE

- D. Attach 80-110 psi air source to gauge fill valve; move height control valve over-travel arm upward (intake position) and hold in this position for approximately 30 seconds.



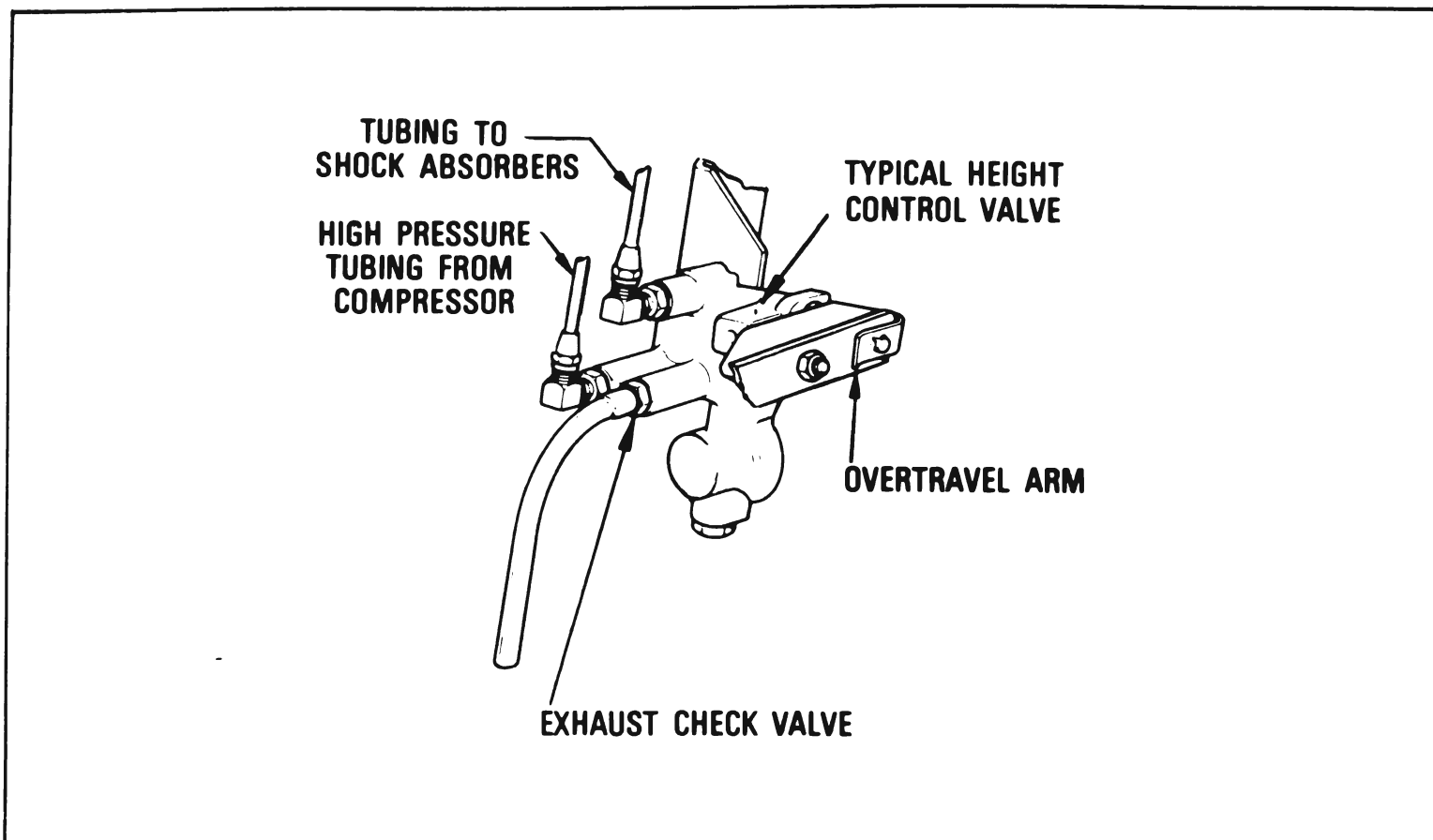
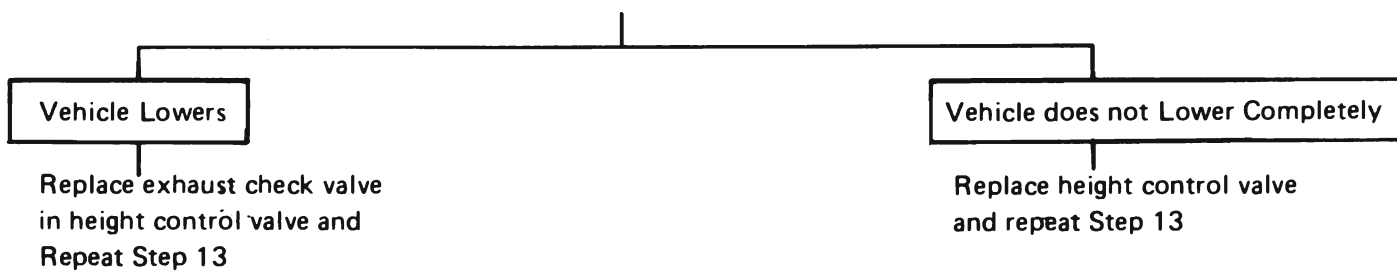

FIGURE 11- LOCATION OF EXHAUST CHECK VALVE



MAINTENANCE AND ADJUSTMENTS

TRIM ADJUSTMENT - ON CAR

Trim adjustment should be performed with a full fuel tank (or the equivalent in load at the rate of six pounds per gallon of gasoline added over center of fuel tank.)

Preparation

1. Raise car using drive-on hoist.
2. Remove Superlift air supply line at height control valve. See Figure 9F-20.

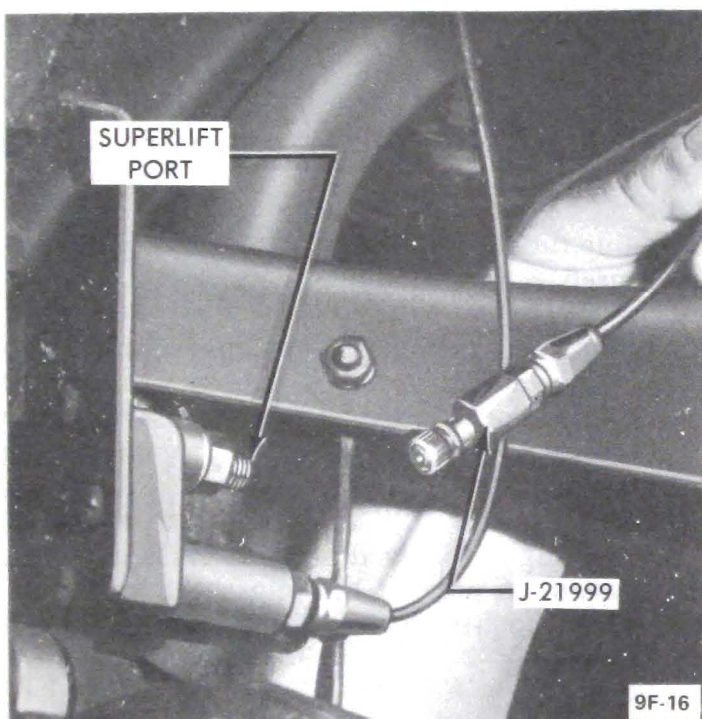

Figure 9F-20 - Superlift Air Supply Line Removed

3. Connect male end of Fill Valve Assembly, J-21999, to Superlift air supply line.
4. Inflate Superlifts to 8-15 psi, use tire gage on fill valve to determine pressure. Jounce car to neutralize suspension.
5. Connect test gage J-22124 to Superlift outlet on height control valve and attach an 80-110 psi air pressure source to test gage. See Figure 9F-21.

Adjustment

1. Loosen height control valve lever adjusting nut. See Figure 9F-22.
2. Hold overtravel body down in exhaust position until air escapes from exhaust port. See Figure 9F-23.

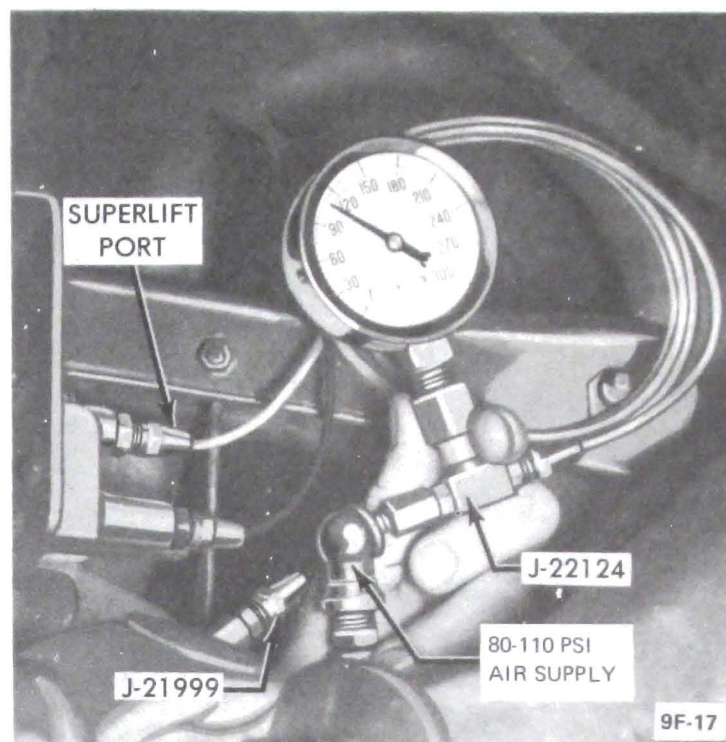

Figure 9F-21 - Connect Test Gage to Superlift Outlet

3. Slowly move overtravel body toward neutral position and point of minimum air bleed thru exhaust port. Tighten nut to 75 lb.in. With nut tight, a slight continuous air bleed should be noticeable thru exhaust port.

Restore System

1. Remove test gage and air pressure source from Superlift outlet on height control valve.

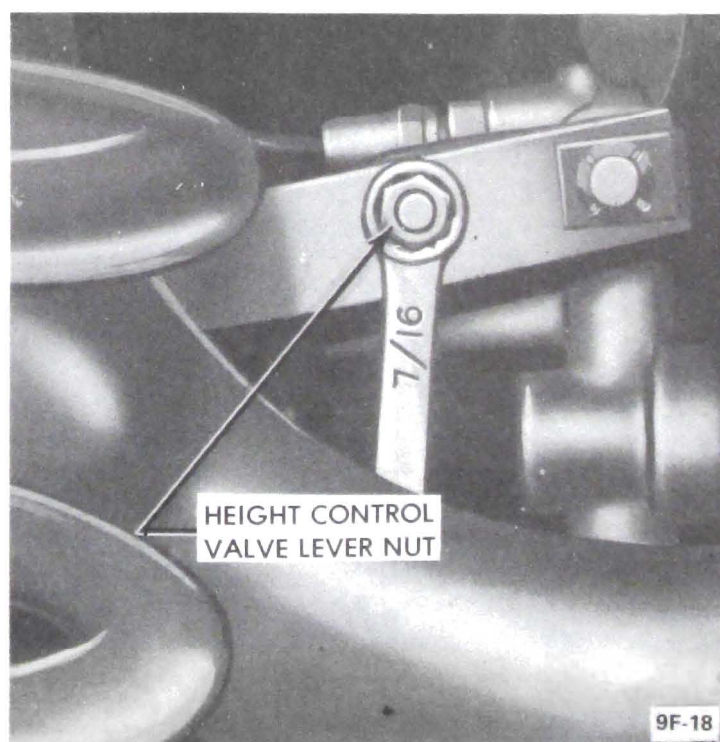

Figure 9F-22 - Loosen Height Control Valve Lever Nut

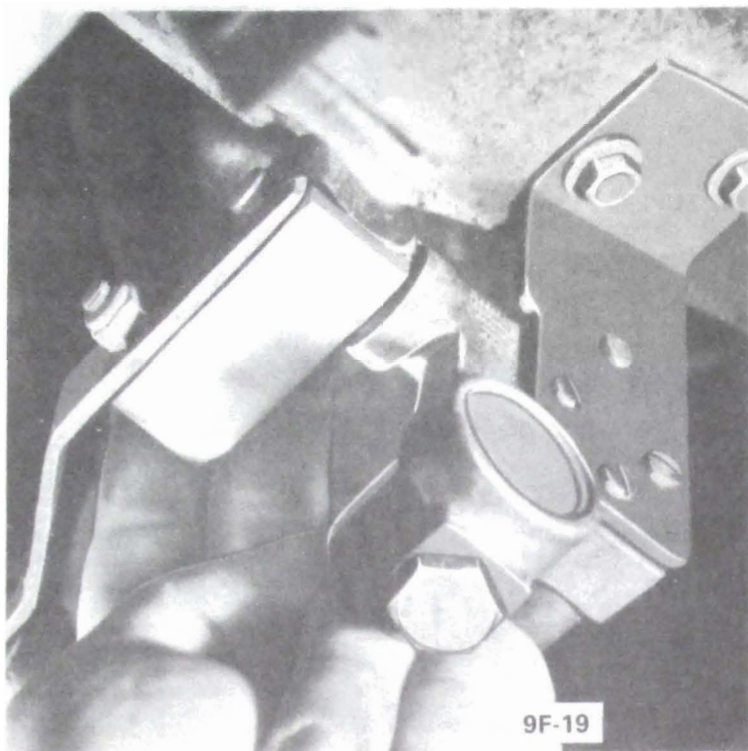

Figure 9F-23 - Hold Overtravel Body in Exhaust Position

2. Remove Fill Valve Assembly from Superlift air supply line and reconnect line to height control valve. Torque to 70 lb.in.

3. Lower car and inflate system through service valve on compression. See Figure 9F-33. Load rear suspension and allow car to come to level position. Unload rear suspension, this will put the minimum 8 to 15 psi air pressure in the Superlifts.

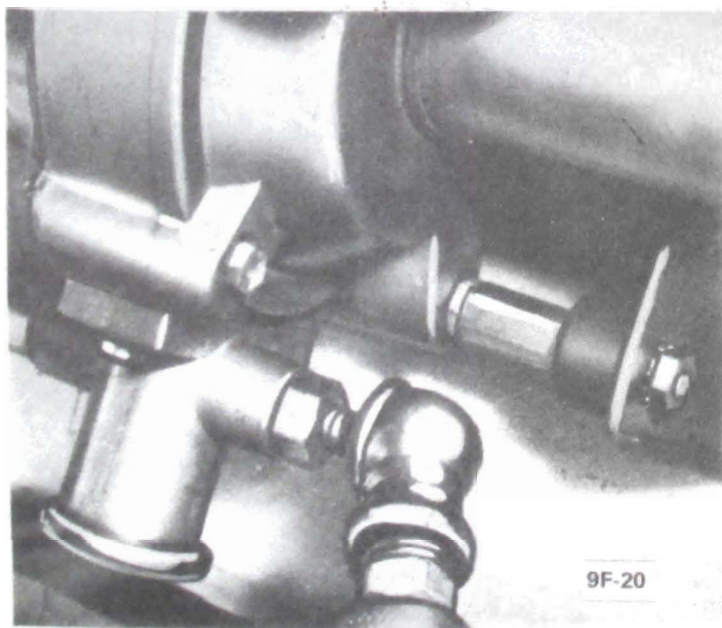

Figure 9F-24 - Filling System Through Service Valve

MAJOR REPAIR

REMOVAL AND INSTALLATION OF TUBING

While the lines are flexible for easy routing and handling, care should be taken not to kink them and to keep them from coming in contact with the exhaust system.

Tubing may be removed by simply unscrewing a fitting nut. Be sure system is deflated thru service valve before separating air lines. When installing tubing at any Automatic Level Control fitting, be careful not to kink line.

1. Preassemble metal sleeve and rubber seal. See Figure 9F-14.
2. Place nut on tubing.
3. Insert tube into metal sleeve and rubber seal until tube bottoms.
4. Holding tubing in bottomed position, tighten tube nut securely (70 lb.in.)

Tubing may be reinstalled at its connections. If tubing is cracked at end, it will be necessary to cut flush and use a new metal sleeve and rubber seal assembly as described above. Be careful not to remove too much tubing, or tubing may be kinked or broken at full suspension travel. Care should be taken that proper routing is followed in areas close to the exhaust system to prevent burning the tubing. Note particularly the areas at rear suspension cross member.

REMOVAL AND INSTALLATION OF COMPRESSOR, RESERVOIR AND REGULATOR VALVE ASSEMBLY

Removal

1. Deflate system through service valve.
2. Disconnect high pressure line at pressure regulator valve. Also disconnect vacuum line at compressor.
3. Remove nuts securing the assembly to the brackets and remove assembly.

Installation

1. Install assembly in brackets and tighten nuts to 30 lb inch.
2. Connect high pressure line to regulator valve and tighten fitting nut to 70 lb. inch. Install vacuum line to compressor.

3. Inflate system through service valve to maximum available pressure. See Figure 9F-30. If available pressure is less than 140 psi, start engine to build up reservoir to this pressure.

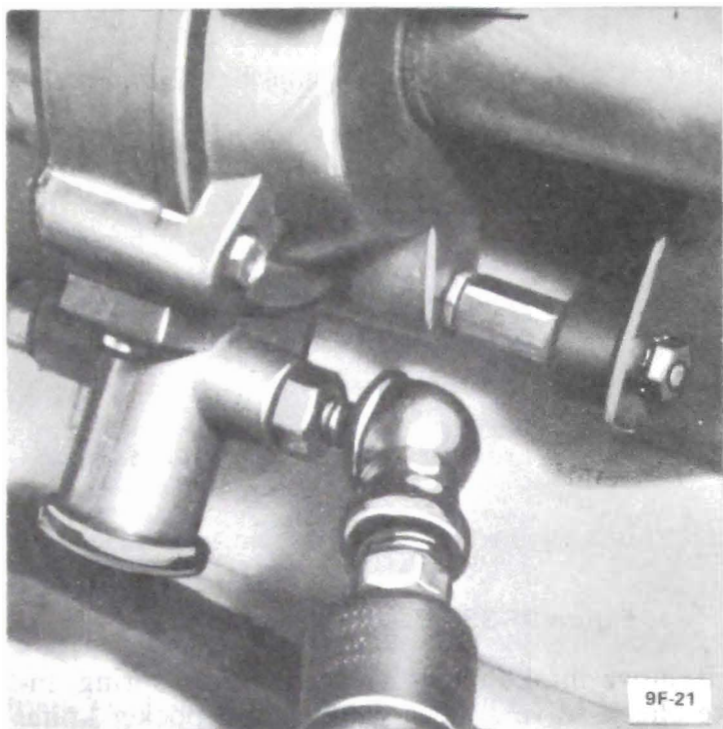

Figure 9F-30 - Filling System Through Service Valve

DISASSEMBLY OF COMPRESSOR ASSEMBLY

Disassembly of Compressor into Major Components

The compressor is a precision built mechanism that should be carefully handled and assembled. Care must be taken to prevent entrance of dirt or other foreign matter. This unit must not be lubricated as it is designed to operate dry.

1. Remove compressor as outlined in "Removal and Installation of Compressor, Reservoir and Regulator Valve Assembly" procedure.
2. Remove two adapters and flexible mounts on compressor end of assembly.
3. Remove nuts from three reservoir retaining (long) bolts. The bolts enter from reservoir flange side of unit.
4. Remove nuts from three compressor retaining (short) bolts. These bolts enter from compressor side of unit. **DO NOT** attempt to turn short bolts as they have a second nut hidden between reservoir flange and second stage housing. Always remove nuts from bolts while holding bolts stationary.
5. Separate compressor assembly and reservoir. Discard reservoir sealing "O" ring.
6. Remove cover retaining screw. Remove cover and

discard cover gasket.

7. Remove three compressor retaining (short) bolts that hold first and second stage housings together.

8. Separate first and second stage housings by sliding second stage housing straight off piston.

9. Remove two pressure regulator valve assembly retaining screws. Remove valve assembly from second stage housing and discard "O" ring seal.

10. Disconnect distributor arm tension spring from swivel arm.

11. Remove actuating arm retaining screw and arm.

12. Piston and diaphragm assembly can now be removed from first stage housing by carefully sliding the assembly straight out of housing.

Disassembly of Piston - Diaphragm Assembly

1. Remove snap ring with Truarc pliers. See Figure 9F-31.



Figure 9F-31 - Removing Snap Ring

2. Remove diaphragm plate, diaphragm, second diaphragm plate and corprene washer. The diaphragm and corprene washer can be discarded.

3. Remove and discard piston seals and "O" rings from piston. Be careful not to damage piston.

4. Remove check valve in second stage end of piston by inserting a suitable punch or piece of 3/32" welding rod through air passage from first stage end and tapping.

Disassembly of First Stage Housing and Valve Mechanism

Actuate distributor valve with finger. Valve tension spring should press against distributor valve, holding it against either stop. If valve action is not free and positive, it will be necessary to rebuild using new parts in Distributor Valve Package. If action is free and positive and upon disassembly there are no damaged parts, parts may be re-used.

1. Remove screw, washer, distributor arm assembly, washer and distributor valve bushing. See Figure 9F-32.

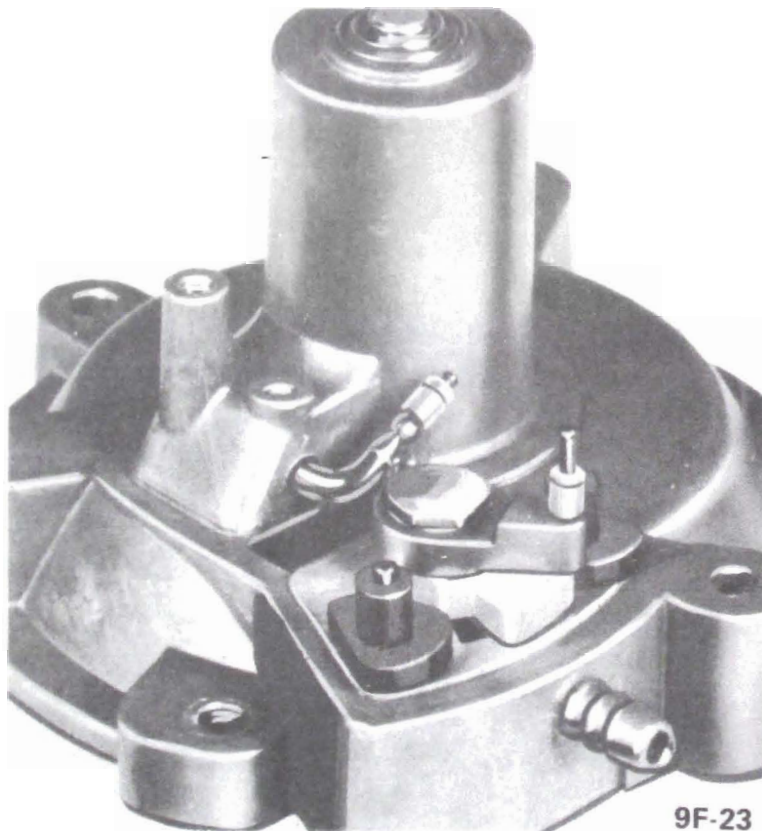
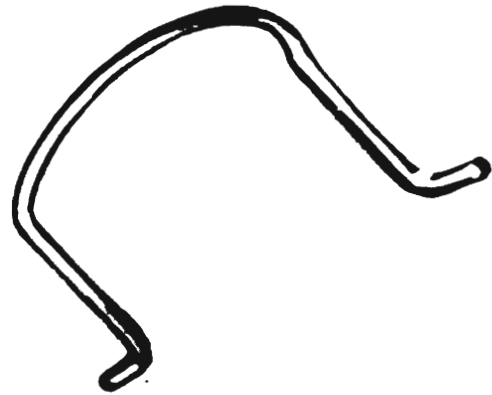

Figure 9F-32 - Removal of Distributor Valve

2. Remove two arm assembly stop bushings and two distributor valve stop bushings.

3. Remove distributor valve being careful not to distort valve tension spring.

4. Carefully remove valve tension spring from boss. Do not distort spring. Tension spring has one short foot and one long foot. The short foot fits under the distributor valve and the long foot fits into a hole drilled at an angle in the boss. See Figure 9F-33.



9F-24

Figure 9F-33 - Valve Tension Spring

5. Remove intake check valve retaining spring, intake check valve and washer using a pocket knife.

6. If necessary, remove rocker and swivel arms. Grip pin with pliers and remove pin. See Figure 9F-34.

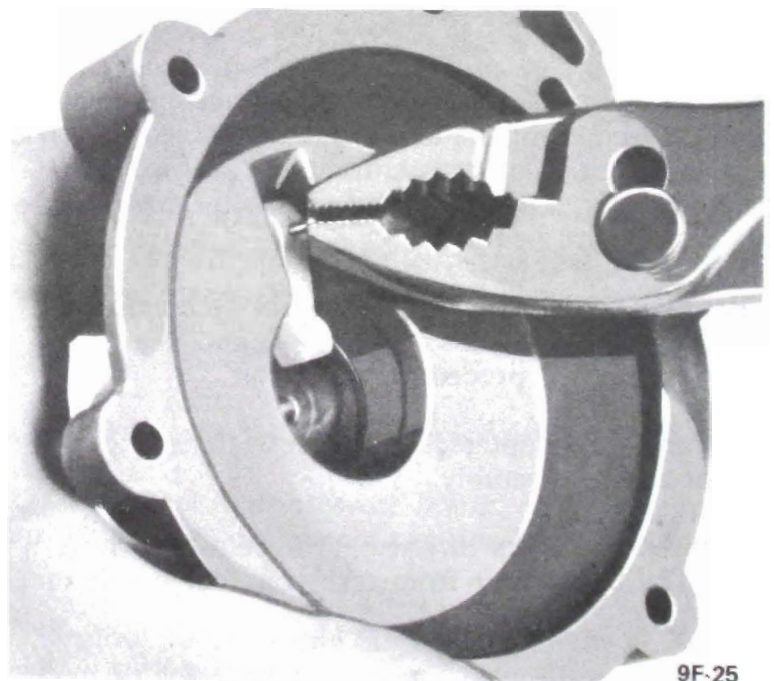

Figure 9F-34 - Removing Rocker Arm Pin

Disassembly of Second Stage Housing

Remove check valve in second stage housing by inserting a suitable punch or piece of 3/32 inch welding rod through air passage and tapping.

CLEANING AND INSPECTION OF PARTS

All metal parts should be cleaned in clean solvent and blown dry with compressed air.

Piston and Diaphragm Assembly

1. Inspect piston for scoring, replace if necessary.
2. Inspect check valve seat. Seat should be smooth and clean.
3. Inspect diaphragm for holes, looseness or other defect, replace if necessary.

First Stage Housing and Valve Mechanism

1. Inspect housing for cracks or damage and replace if necessary.
2. Inspect piston bore, replace housing if scored.
3. Inspect check valve seat. Seat should be smooth and clean.
4. Inspect distributor valve parts for wear and replace if necessary.
5. Inspect distributor valve seat on housing for wear. Replace housing if necessary.

Second Stage Housing

1. Inspect piston bore, replace housing if scored.
2. Inspect check valve seat. Seat should be smooth and clean.
3. Inspect housing for cracks or damage and replace if necessary.

ASSEMBLY OF COMPRESSOR ASSEMBLY

Assembly of Second Stage Housing

1. Install new check valve and spring.
2. Insert new expansion plug retainer and tap in until it bottoms. See Figure 9F-35.

Assembly of First Stage Housing and Valve Mechanism

If distributor mechanism failed to operate properly or one or more parts were found defective, use new parts in Distributor Valve and Arm Package during remaining reassembly.



Figure 9F-35 - Installing Check Valve

1. If removed, position bushings in first stage housing and install rocker arm and swivel arm. Align holes

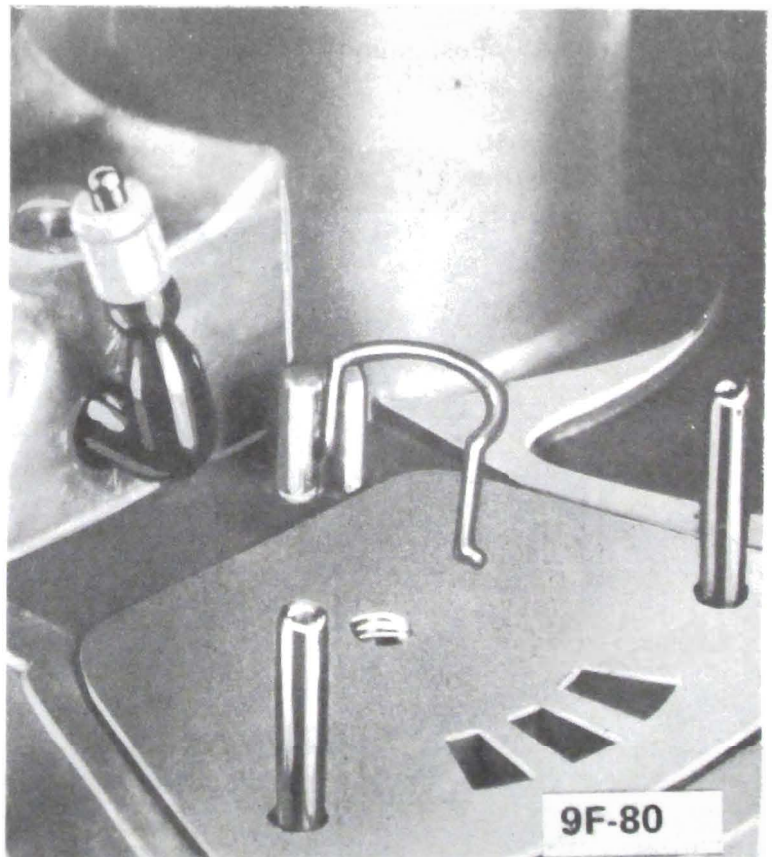

Figure 9F-36 - Installing Valve Tension Spring in Boss

in rocker and swivel arms and install retaining pin, small end first.

2. Install washer on intake valve and install in first stage housing with intake valve retaining spring.

3. Install longer foot of valve tension spring in boss on first stage housing being careful not to distort spring. See Figure 9F-36.

4. Position distributor valve so that short foot of tension spring fits under valve and vertical leg is in slot. See Figure 9F-37.

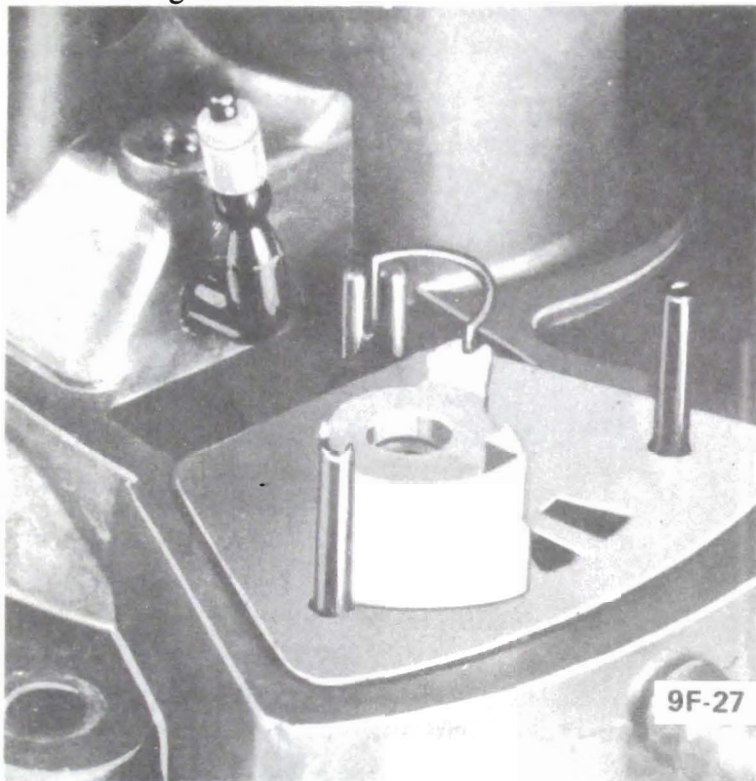

Figure 9F-37 - Positioning Distributor Valve

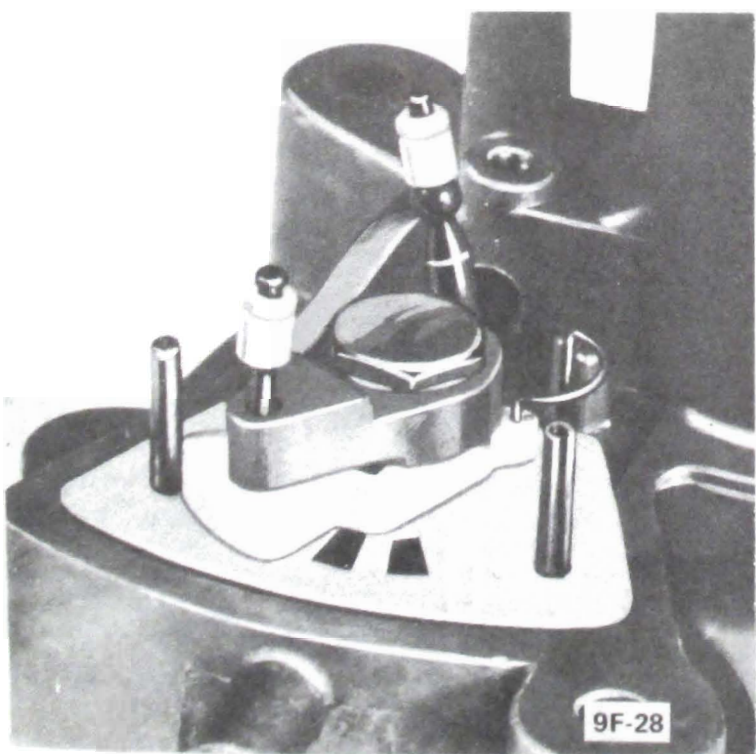

Figure 9F-38 - Installing Distributor Arm Assembly

5. Install distributor valve bushing, washer, distributor arm assembly, washer and secure with screw.

Tighten to 12 lb.in. See Figure 9F-38.

6. Install two distributor valve stop bushings and two arm assembly stop bushings.

Do not install actuating arm, arm tension spring or arm pivot screw at this time as rocker arm must be free to permit entrance of piston into first stage housing.

Assembly of Piston - Diaphragm Assembly

1. Install new corprene washer, old plate (unless damaged), new diaphragm (with outer lip toward second stage end of piston) and second plate. See Figure 9F-39.

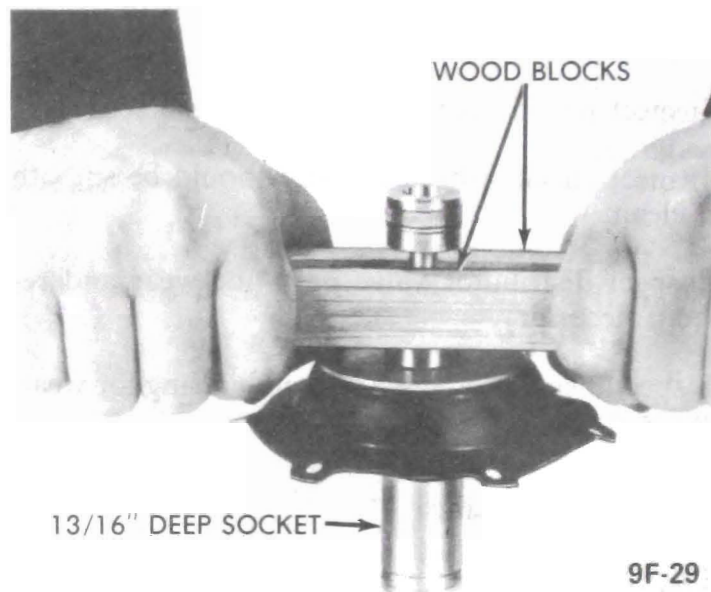

Figure 9F-39 - Installing Diaphragm Retainer

2. Using Truarc pliers, carefully position snap ring over step of piston shoulder.

3. Use a 3/4" deep socket as a pilot for the snap ring. Exert force against the piston shoulder until snap ring slips into groove. The wood blocks are 3/4" x 3/4" x 12".

4. Install new "O" rings by rolling into groove. Relieve any resulting twist.

5. Install new seals using a piece of .020" shim stock. See Figure 9F-40. Make sure shim stock has no sharp edges that may cut seal. Do not stretch seal more than is necessary to install. Seals must be installed so they are not twisted.

Assembly of Major Components

1. Slide piston assembly straight into first stage (large diameter) housing.

2. Install actuating arm and secure to first stage housing with arm pivot screw. Tighten to 12 lb.in.

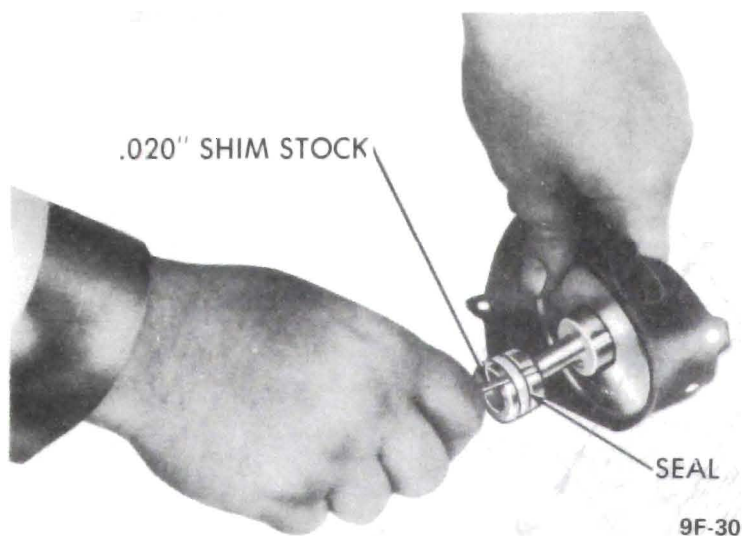

Figure 9F-40 - Installing Piston Seal

3. Connect arm tension spring to swivel arm.

4. Rotate piston in first stage housing to align elongated hole in diaphragm with vent port in housing.

5. Install second stage housing by sliding straight onto second stage piston.

6. Install three compressor retaining (short) bolts from the first stage housing side, through the second

stage housing hex shaped, recessed holes. The first and second stage housings will align one way only. Position three small nuts in hex recesses and tighten bolts to 28 lb. inch.

7. Install new "O" ring on second stage housing. Install reservoir on second stage housing with three large nuts. Tighten to 28 lb. inch. Install the two reservoir retaining (long) bolts, from reservoir side, that do not go through cover. Tighten to 28 lb. inch.

8. Install new gasket and cover and secure with retaining screw. Tighten screw to 35 lb. inch. Install third reservoir retaining (long) bolt. Tighten to 28 lb. inch.

9. Install new "O" ring on pressure regulator and secure with two retaining screws with high pressure fitting toward reservoir. Tighten to 35 lb. inch.

10. Install two adapters and flexible mounts on the two reservoir (long) bolts that do not go through cover. Tighten to 28 lb. inch.

11. Compressor should be output tested before installation on car. See Compressor Output Test on Car paragraph.

12. If compressor passes output test, install Compressor, Reservoir and Regulator Valve Assembly on car.

Tightening Specifications

Use a reliable torque wrench to tighten the parts listed to insure proper tightness without straining or distorting parts. These specifications are for clean and lightly-lubricated threads only; dry or dirty threads produce increased friction which prevents accurate measurement of tightness.

Part	Location	Thread Size	Torque Lbs.In.
Screw	Compressor Bracket to Skirt	1/4-14	96
Nut	Compressor to Bracket	#10-32	30
Bolt	Pressure Regulator Valve to Compressor	#10-32	30
Nut	Reservoir or Compressor Retaining Bolt	#10-32	30
Adapter	Rubber Mount to Compressor Retaining Bolt	#10-32	30
Nut	Height Control Valve Bracket to Frame	1/4-14	90
Screw	Height Control Valve Bracket to Valve	#8-32	18
Nut	Overtravel Body to Lever Adjusting ..	1/4-28 Locking	75
Screw	Vacuum Regulator Valve	1/4-14	96

General Specifications

Compressor, Pressure Regulator Valve, and Tank Assembly	Two Stage, Vacuum Actuated
Shocks	Delco Superlift Direct Double Acting
Spring	All Except Estate Wagon - Coil
Spring	Estate Wagon - Multi-Leaf

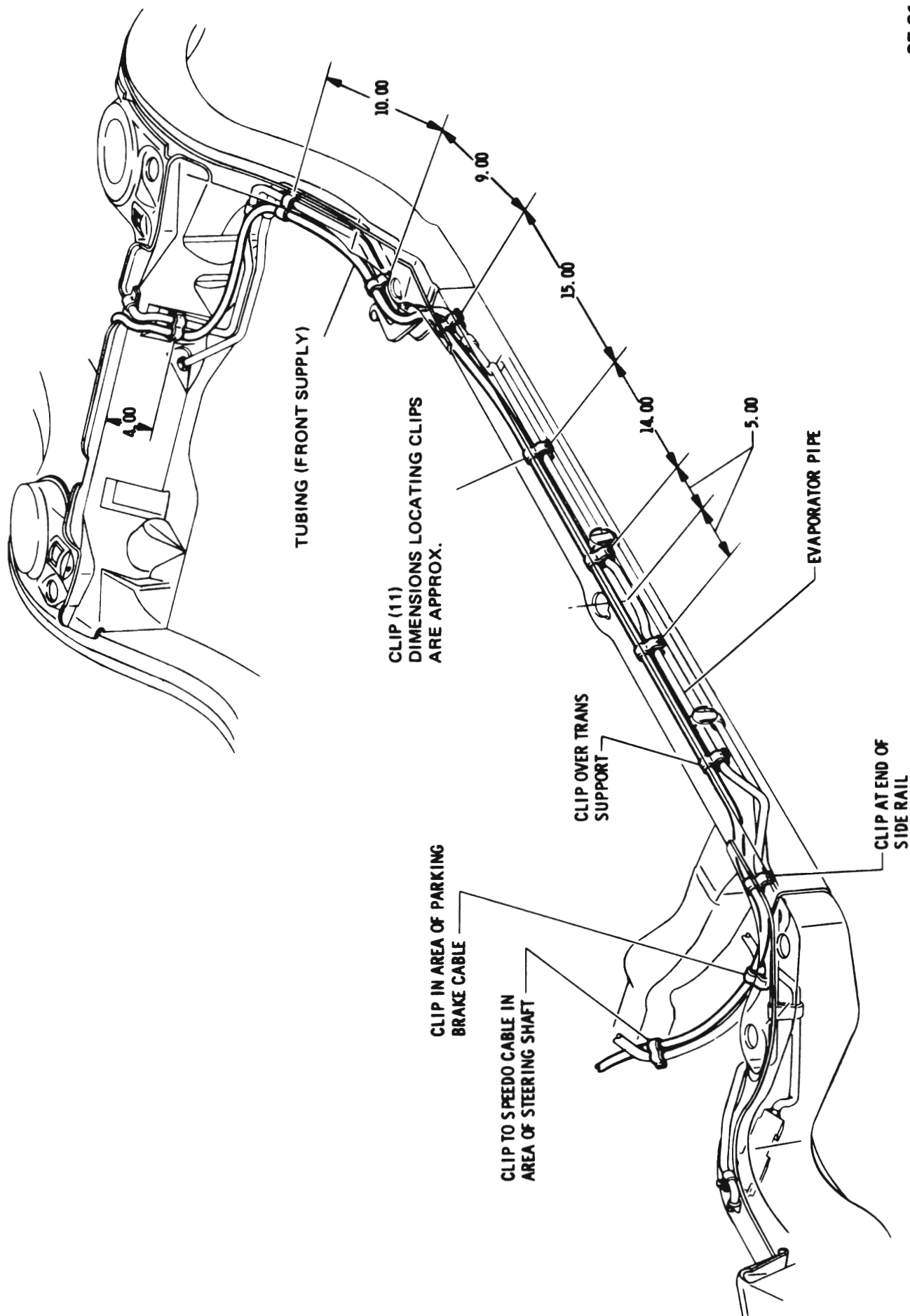

9F-31

Figure 9F-41 - "A" Series - Automatic Level Control Tube Routing to Frame

9F-60

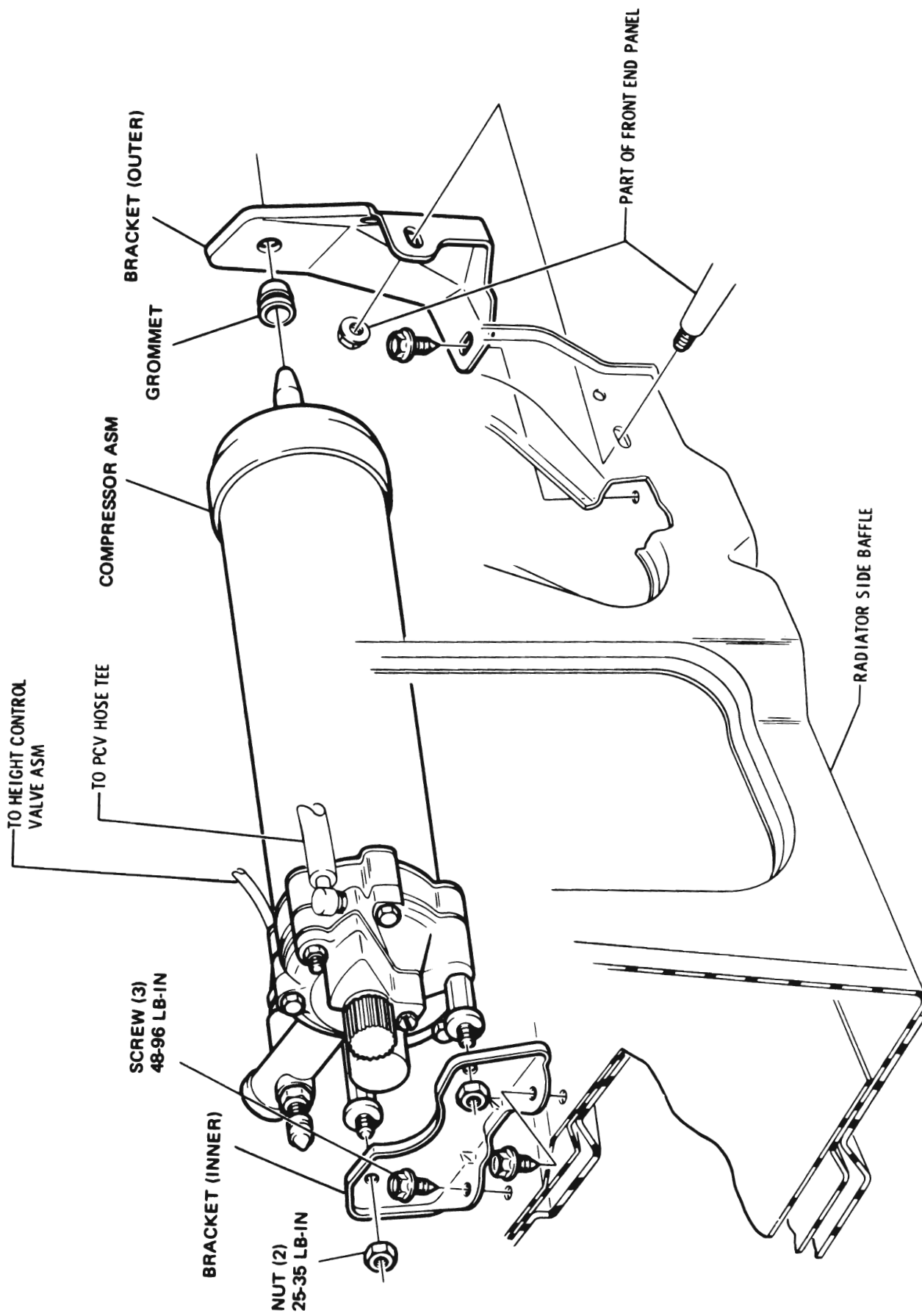

Figure 9F-42 Automatic Level Control Compressor Mounting - "A" Series

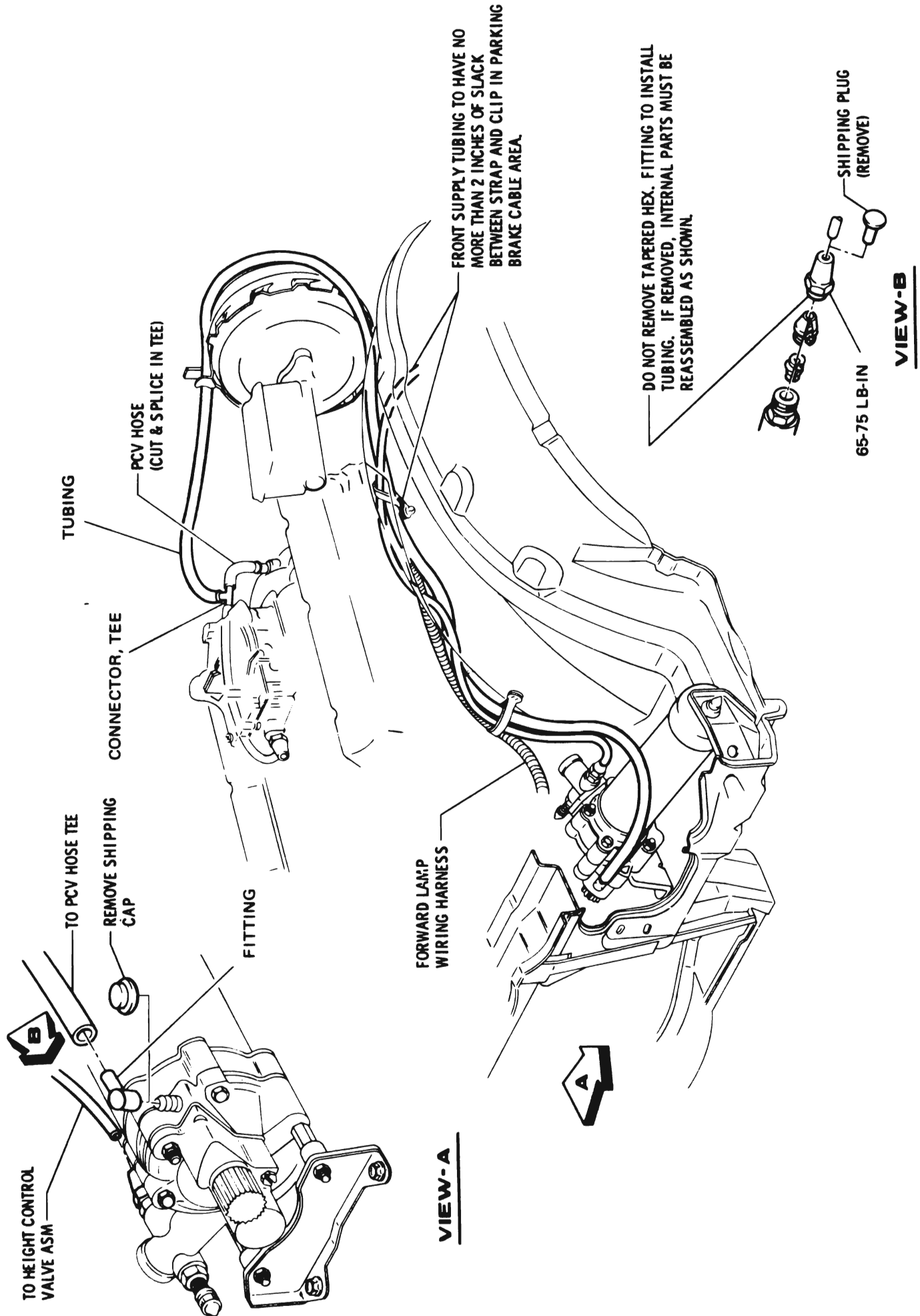

Figure 9F-43 Automatic Level Control Front Hose and Tube Routing - "A" Series

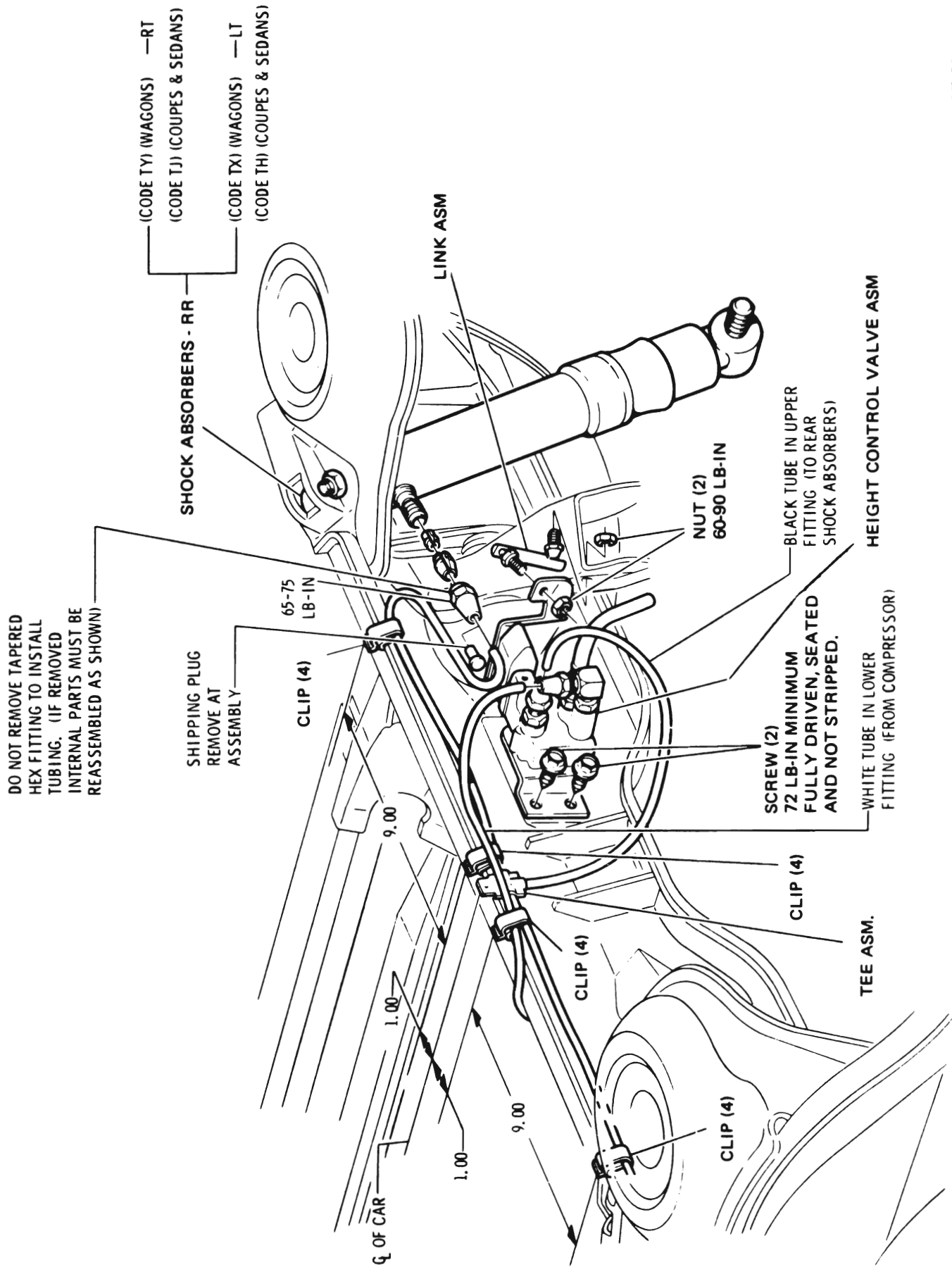
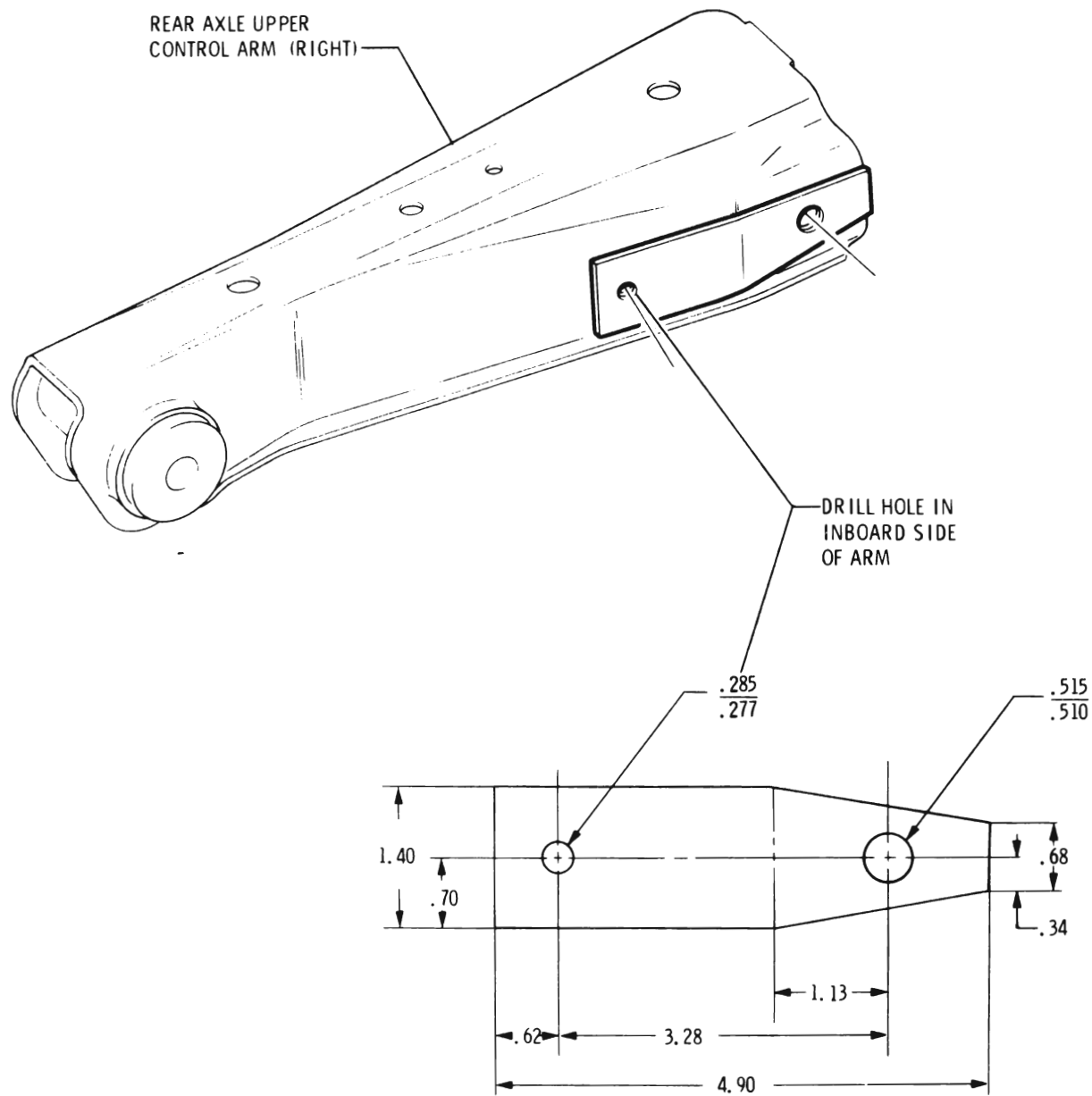

Figure 9F-44 Automatic Level Control Valve Mounting Link and Shock Absorbers - "A" Series



9F-63

@2-9.0 9F-63

Figure 9F-45 Automatic Level Control Template - "A" Series

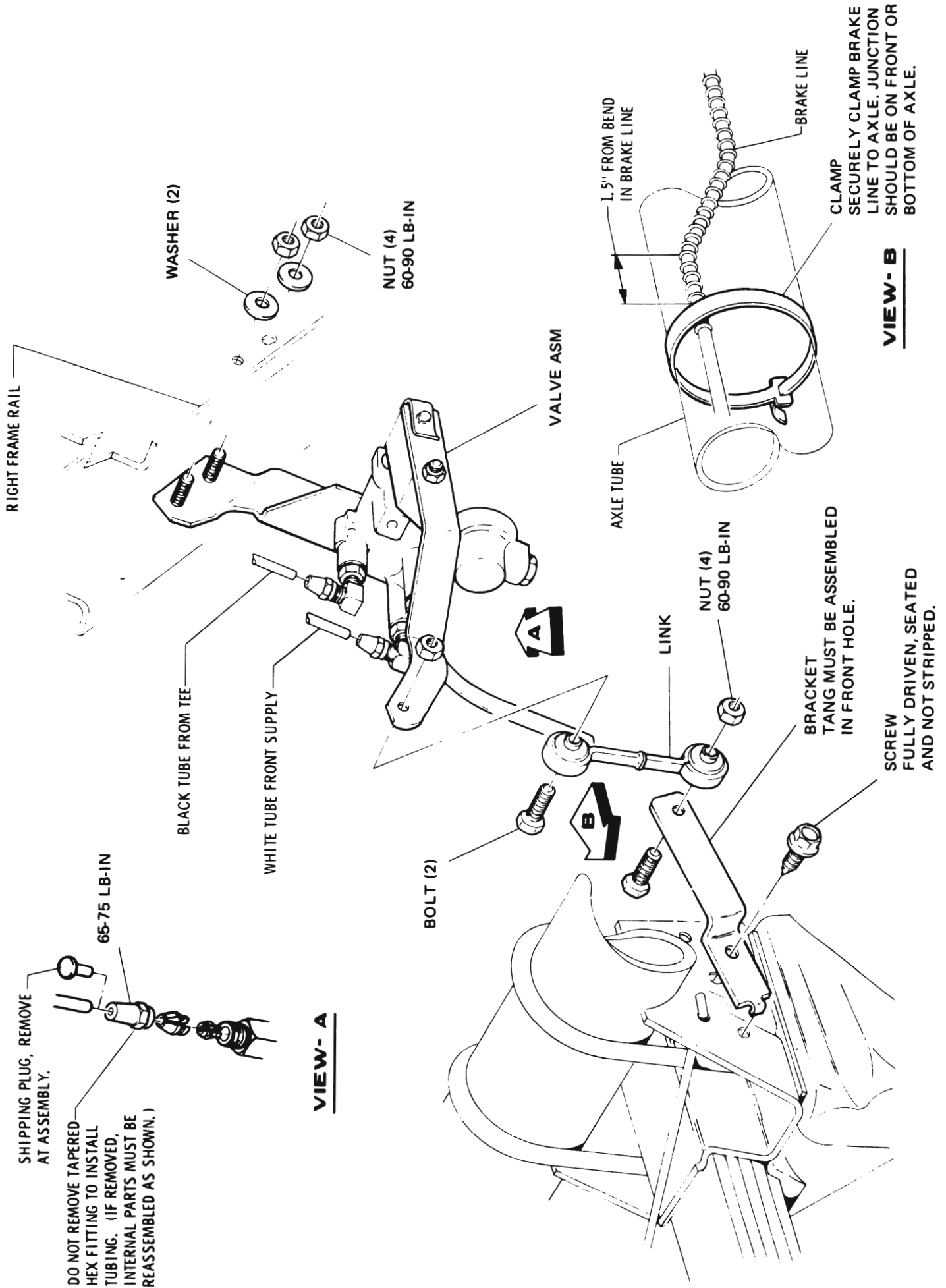

Figure 9F-47 Automatic Level Control Valve Mounting and Link "B" Wagon

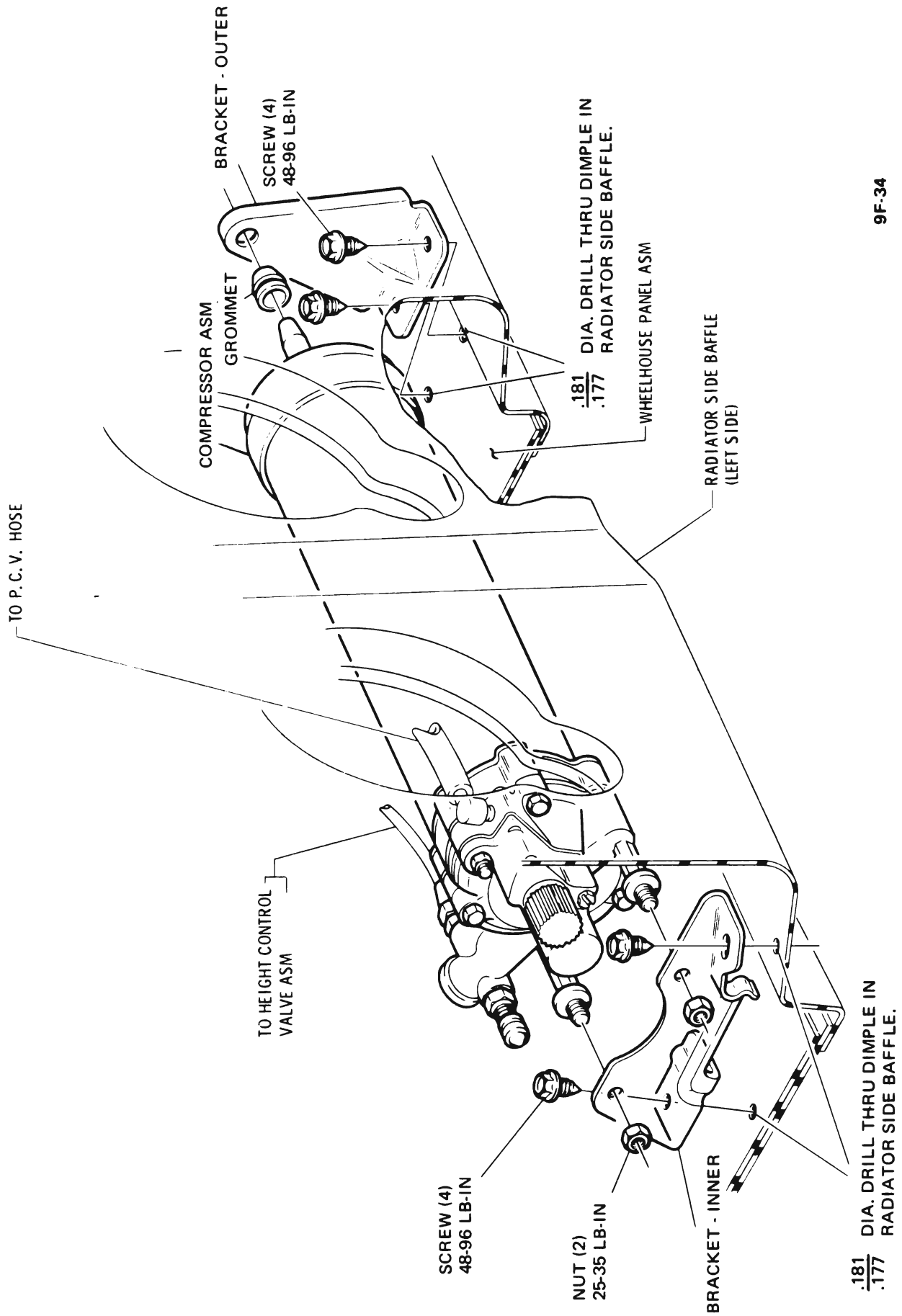

Figure 9F-50 Automatic Level Control Compressor Mounting - "B-C-E" Series

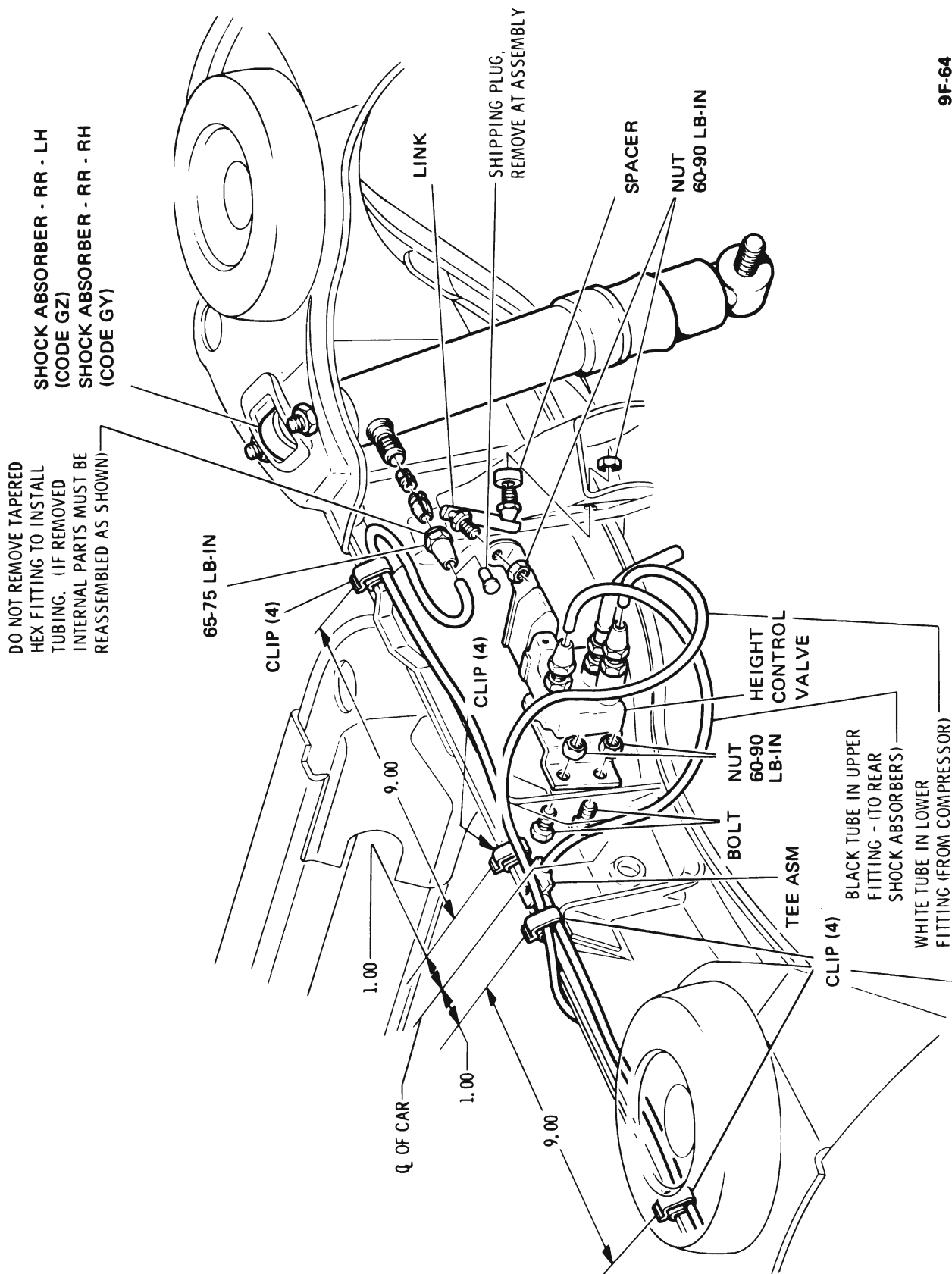
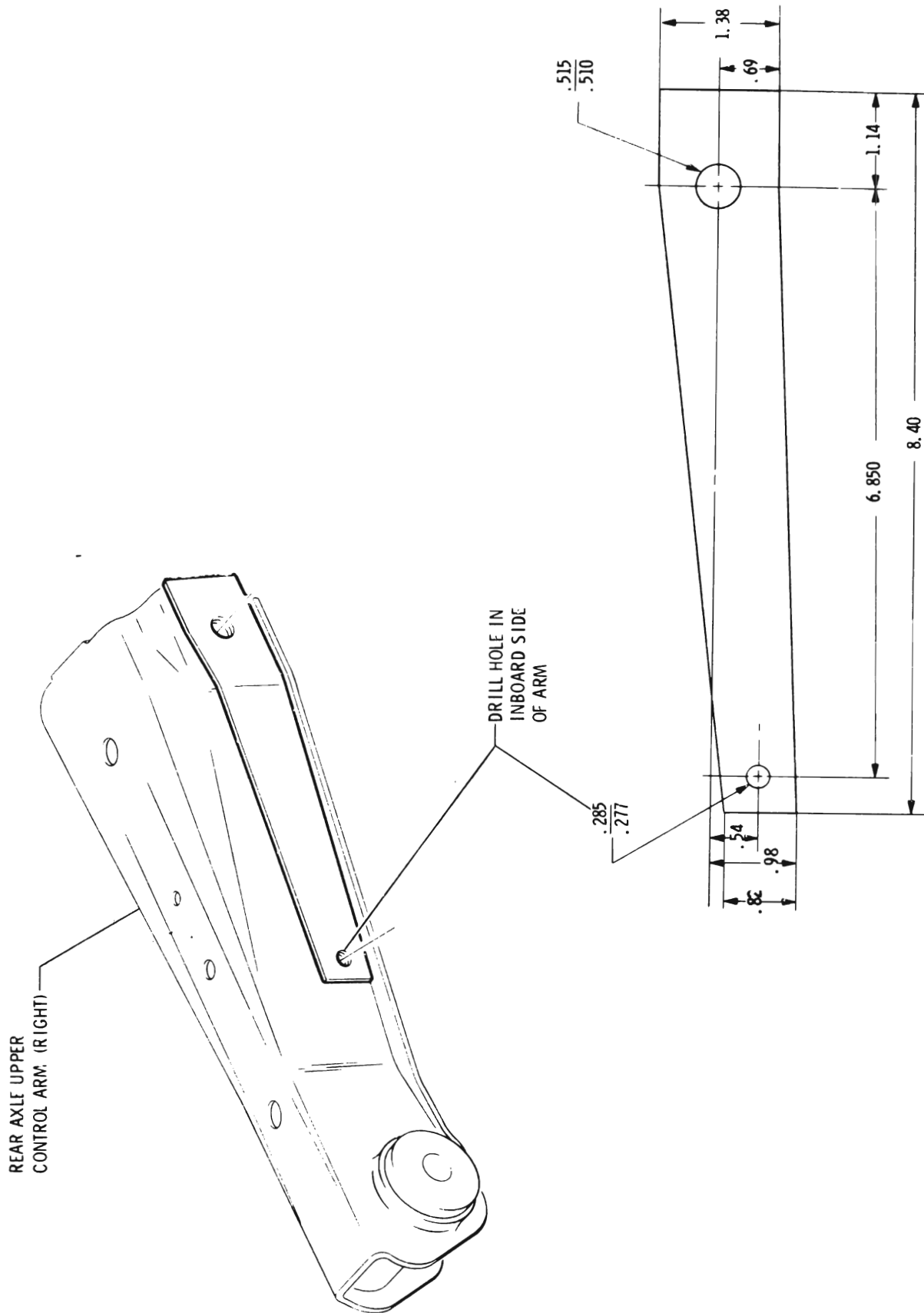

Figure 9F-53 Automatic Level Control Valve Mounting Link and Shock Absorbers - "E" Series



9F-65

@2-9.0 9F-65

Figure 9F-54 Automatic Level Control Template "E" Series

