

MASTER CYLINDER

CONTENTS

	Page No.
DESCRIPTION AND OPERATION:	
Description of Master Cylinder	5C-46
Operation of Master Cylinder	5C-46
DIAGNOSIS:	
Master Cylinder Trouble Diagnosis	5C-47
MAINTENANCE AND ADJUSTMENTS:	
Filling Brake Master Cylinder	5C-47
MAJOR REPAIR:	
Removal of Brake Master Cylinder	5C-48
Disassembly of Brake Master Cylinder	5C-48
Inspection of Brake Master Cylinder	5C-49
Assembly of Brake Master Cylinder	5C-49
Installation of Brake Master Cylinder	5C-53
SPECIFICATIONS:	
Tightening Specifications	5C-53
General Specifications	5C-53

DESCRIPTION AND OPERATION

DESCRIPTION OF MASTER CYLINDER

The master cylinder contains two fluid reservoirs and two cylindrical pressure chambers in which force applied to the brake pedal is transmitted to the fluid which actuates the brake shoes. Breather ports and compensating ports permit passage of fluid between each pressure chamber and its fluid reservoir during certain operating conditions. A vented cover and flexible rubber diaphragm at the top of the master cylinder reservoirs seal the hydraulic system from possible entrance of contamination, while at the same time permitting expansion or contraction of fluid within the reservoirs without direct venting. In the pressure chambers, coil springs hold rubber primary cups against the end of the pistons. These cups and rubber secondary seals on the opposite end of the pistons prevent escape of fluid past the pistons. The piston is retained in the cylinder by a stop plate. A rubber boot is installed over this end of the cylinder to exclude foreign matter. See Figure 5C-1 and 5C-2.

OPERATION OF MASTER CYLINDER

When the brake pedal is depressed, force is transferred through the push rod to the master cylinder

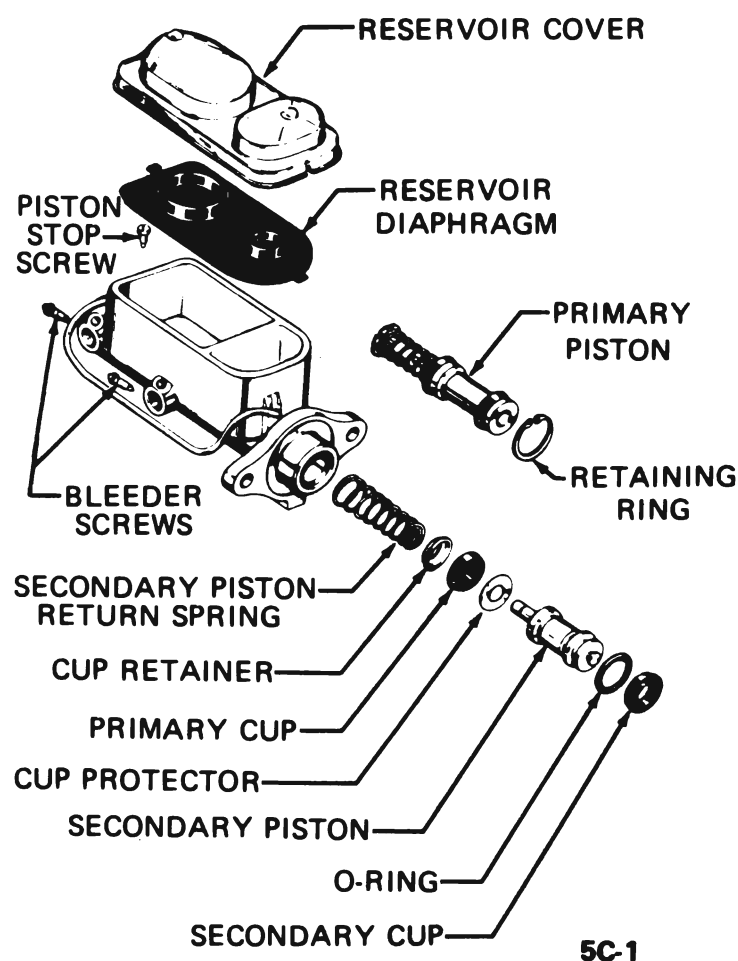
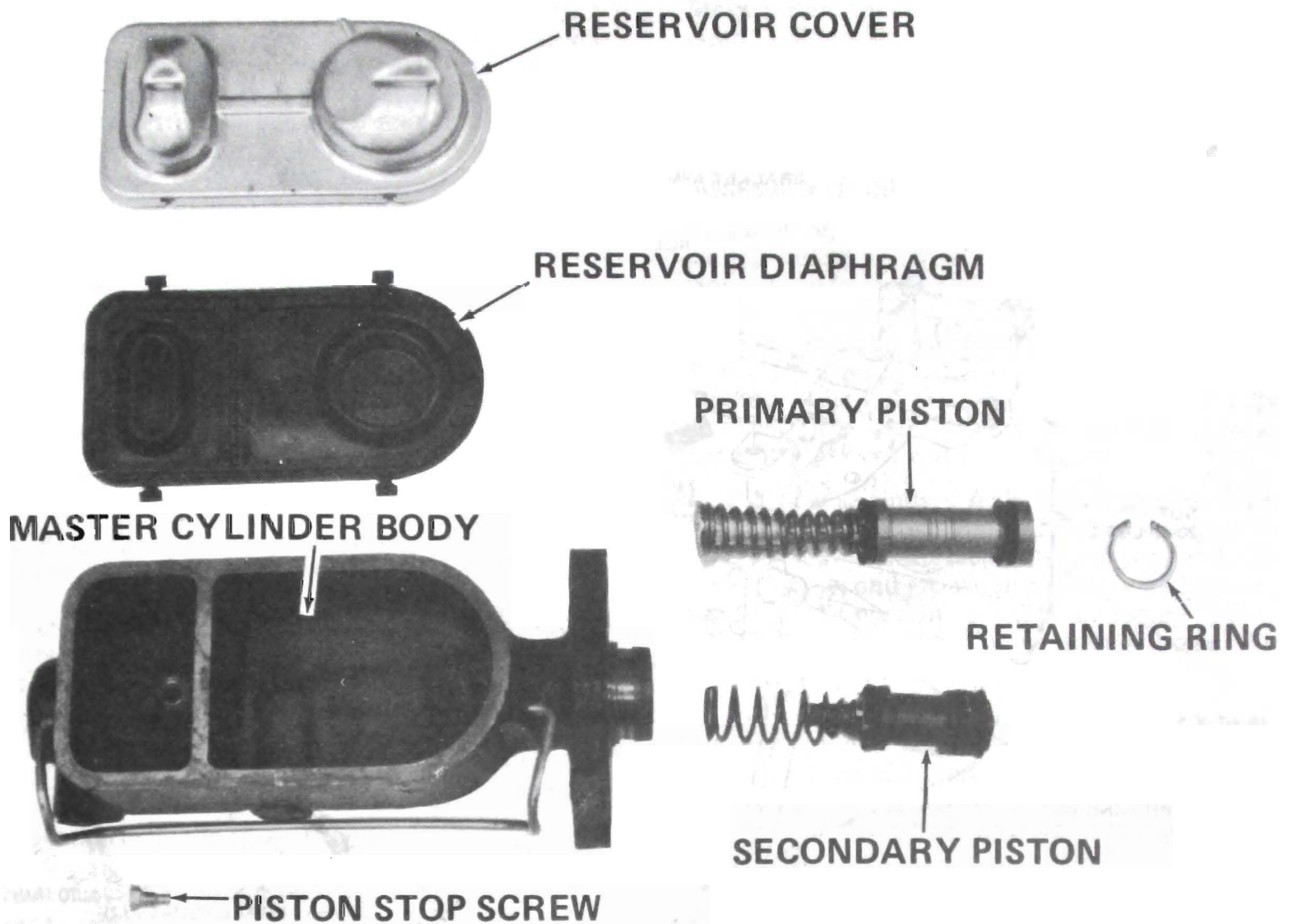

Figure 5C-1 Exploded View - Power Brake Master Cylinder



5C-2

Figure 5C-2 Exploded View - Manual Brake Master Cylinder

primary piston which moves forward. Under normal conditions, the combination of hydraulic pressure and the force of the primary piston spring move the secondary piston forward at the same time. When the pistons have moved forward so that their primary cups cover the bypass holes, hydraulic pressure is built up and transmitted to the front and rear wheels. Hydraulic pressure behind the wheel cylinder cups forces the pistons outward, causing the brakes to be applied.

As pressure drops in the master cylinder, shoe springs retract all brake shoes and the connecting links push the wheel cylinder pistons inward, forcing fluid back to the master cylinder.

DIAGNOSIS

BRAKE TROUBLE DIAGNOSIS

Refer to brake trouble diagnosis chart in drum brake section of this group.

MAINTENANCE AND ADJUSTMENTS

FILLING BRAKE MASTER CYLINDER

The master cylinder must be kept properly filled to insure adequate reserve and to prevent air from entering the hydraulic system. However, because of expansion due to heat absorbed from brakes and from engine, master cylinder must not be overfilled.

The brake fluid reservoir is on the master cylinder which is located under the hood on the left side of the dash.

Thoroughly clean reservoir cover before removal to avoid getting dirt into reservoir. Remove cover and diaphragm. Add fluid as required to bring level to 1/4" (plus or minus 1/8") from the lowest portion of the top of each reservoir. Use Delco Supreme No. 11 Hydraulic Brake Fluid or equivalent.

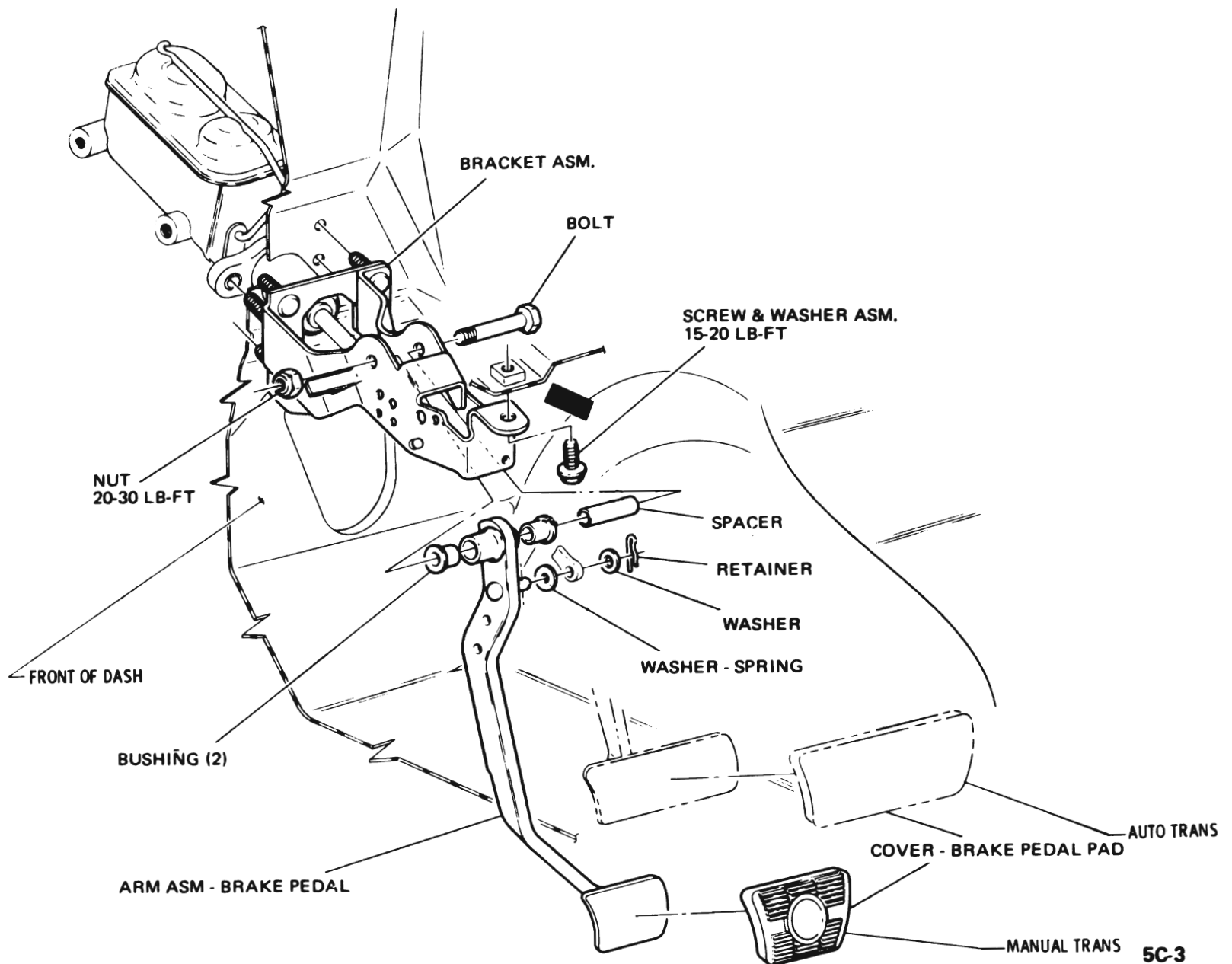

Figure 5C-3 Push Rod Retainer Clip

Do not use shock absorber fluid or any other fluid which contains mineral oil. Do not use a container which has been used for mineral oil. Even a trace of mineral oil will cause swelling and distortion of rubber parts in the hydraulic brake system.

MAJOR REPAIR

MASTER CYLINDER OVERHAUL

Removal of Brake Master Cylinder

1. Disconnect brake pipes from master cylinder and tape end of pipes to prevent entrance of dirt.
2. (Manual brake only) Disconnect brake pedal from master cylinder push rod by removing retainer clip and clevis pin. See Figure 5C-3.

3. Remove two nuts holding master cylinder to dash or power cylinder and remove master cylinder from car. Be careful not to drip brake fluid on exterior paint.

Disassembly of Brake Master Cylinder

1. Clean outside of master cylinder thoroughly. Remove reservoir cover and diaphragm. Turn cylinder over and pump push rod by hand to drain all brake fluid. Always discard used fluid.
2. (Manual brake only) Pull boot away from master cylinder to uncover push rod retainer. The retainer has a small, depressed tab in the side. This tab must be pried up to release retainer.
3. Depress piston and remove secondary piston stop bolt from bottom of front fluid reservoir.

4. Place master cylinder in a vise so that lock ring can be removed from groove in the inside diameter of bore. Remove lock ring and primary piston assembly. Remove secondary piston, secondary piston spring and retainer by blowing air through the stop bolt hole. If no air is available, a piece of wire may be used. Bend about 1/4" of one end into a right angle. Hook this end under edge of the secondary piston and pull it out.

5. Place master cylinder in vise, so that outlet holes are up. Enlarge hole in tube fitting insert using a 13/64" drill. Place a heavy washer over outlet on master cylinder and thread a 1/4-20 x 3/4" screw into the insert. Tighten screw until insert is unseated. Remove insert, screw, and washer.

6. Remove primary seal, primary seal protector and two secondary seals from secondary piston.

7. Use clean brake fluid to clean all metal brake parts thoroughly. Air dry and place cleaned parts on clean paper or lint free clean cloth.

Do not use anti-freeze alcohol, gasoline, kerosene, or any other cleaning fluid that might contain even a trace of mineral oil.

Inspection of Brake Master Cylinder

Inspect cylinder bore for scoring or corrosion. It is best to replace a corroded cylinder. Corrosion can be identified as pits or excessive roughness.

Polish any discolored or stained area with crocus cloth by revolving cylinder on cloth supported by a finger.

Rinse cylinder in clean brake fluid. Shake excess rinsing fluid from cylinder. Do not use a rag to dry cylinder, as lint from rag cannot be kept from cylinder bore surfaces.

Make certain that compensating port in cylinder is clear.

If scratches or corroded spots are too deep to be polished satisfactorily, the cylinder should be replaced.

ASSEMBLY OF BRAKE MASTER CYLINDER

1. Place brass tube fitting insert (new parts) in outlet holes, so that it is in a position to be pressed into outlet hole. The recommended method of inserting tube fitting insert is to thread a spare brake line tube nut into outlet hole and turn nut down until tube fitting insert bottoms. Remove tube nut and check outlet hole for loose burrs, which might have been turned up when tube fitting insert was pressed down.

2. Put new secondary seals in two grooves in end of secondary piston. The seal which is nearest the end will have its lip facing toward that end. The seal in the second groove should have its lip facing toward the portion of the secondary piston, which contains the compensating holes. See Figure 5C-4.

3. Assemble a new primary seal protector and primary seal over end of secondary piston, so that flat side of the seal seats against the seal protector and the protector against flange of piston which contains the compensating holes. See Figure 5C-4.

4. Assemble new secondary seal into groove on push rod end of the primary piston. The lip of seal should face toward the compensating holes in opposite end of primary piston. See Figure 5C-4.

5. In order to insure correct assembly of the primary assembly, a complete primary piston assembly is included in the repair kits.

6. Remove all cleaning liquid from threaded hole in primary piston. Place piston extension screw

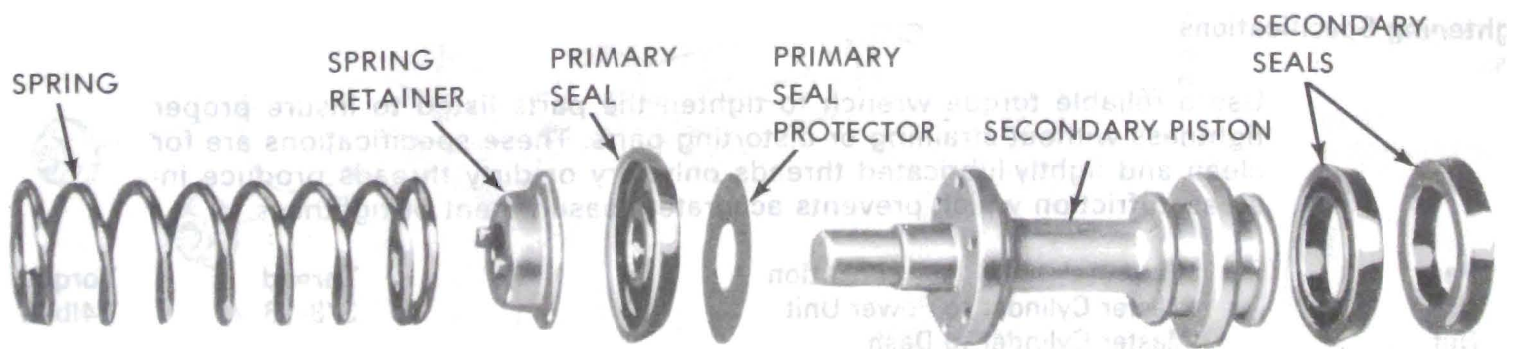

5C-4

Figure 5C-4 Secondary Piston - Exploded View

down through secondary piston stop and primary spring retainer. Tighten screw into primary piston until it bottoms. Torque 80-100 lb. in.

7. Coat bore of master cylinder with clean brake fluid. Coat primary and secondary seals on secondary piston with clean brake fluid. Insert the secondary piston spring retainer into secondary piston spring. Place retainer and spring over end of secondary piston, so that retainer locates inside lip of primary cup.

8. Hold master cylinder with open end of bore down, push secondary piston into bore, so that spring will seat against closed end of bore.

9. Place master cylinder in a vise with open end of bore up. Coat primary and secondary seal on primary piston with clean brake fluid. Push primary piston assembly, spring end first, into bore of master cylinder. Hold the piston down and snap lock ring into position in groove in inside diameter of bore.

10. Continue to hold primary piston down and install stop screw.

11. Install a new reservoir diaphragm in reservoir cover where needed, and install cover on master cylinder. Beaded side faces master cylinder casting to insure positive sealing. The bail wire is now pushed into position to hold reservoir cover.

12. (Manual brake only.) Assemble push rod through push rod retainer, if it has been disassembled. Push retainer over end of master cylinder. Assemble new boot over push rod and press it down over the push rod retainer. Thread jam nut down to shoulder on push rod. **THREAD CLEVIS DOWN TO JAM NUT.** Torque nut against clevis to 14 lb.ft.

SPECIFICATIONS

MASTER CYLINDER SPECIFICATIONS

Tightening Specifications

Use a reliable torque wrench to tighten the parts listed to insure proper tightness without straining or distorting parts. These specifications are for clean and lightly-lubricated threads only; dry or dirty threads produce increased friction which prevents accurate measurement of tightness.

Part	Location	Thread	Torque
Nut	Master Cylinder to Power Unit	3/8-16	24lb.ft.
Nut	Master Cylinder to Dash	3/8-16	24lb.ft.
	Brake Pipes to Master Cylinder		150lb.ft.
	Push Rod to Brake Pedal		Retainer

General Specifications

Master Cylinder Piston Diameter (Manual Brakes)	1"
Master Cylinder Piston Diameter (Power Brakes)	1 1/8"
Approved Hydraulic Brake Fluid	GM or Delco Supreme No. 11 or Equivalent

CAUTION: *This brake pedal to master cylinder clevis fastener is an important attaching part in that it could affect the performance of vital components and systems, and/or could result in major repair expense. It must be replaced with one of the same part number, or with an equivalent part, if replacement becomes necessary. Do not use a replacement part of lesser quality or substitute design. Torque values must be used as specified during reassembly to assure proper retention of this part.*

Installation of Brake Master Cylinder

1. Install master cylinder on dash or power cylinder. Torque nuts to 24 lb. ft.

CAUTION: *This brake master cylinder to cowl fastener is an important attaching part in that it could affect the performance of vital components and systems, and/or could result in major repair expense. It must be replaced with one of the same part number, or with an equivalent part, if replacement becomes necessary. Do not use a replacement part of lesser quality or substitute design. Torque values must be used as specified during reassembly to assure proper retention of this part.*

2. (Manual brake only) Connect push rod to brake pedal by installing clevis pin and retainer clip.

3. Connect brake pipes to master cylinder.

4. Bleed hydraulic system.

5. Road test car for proper brake performance.

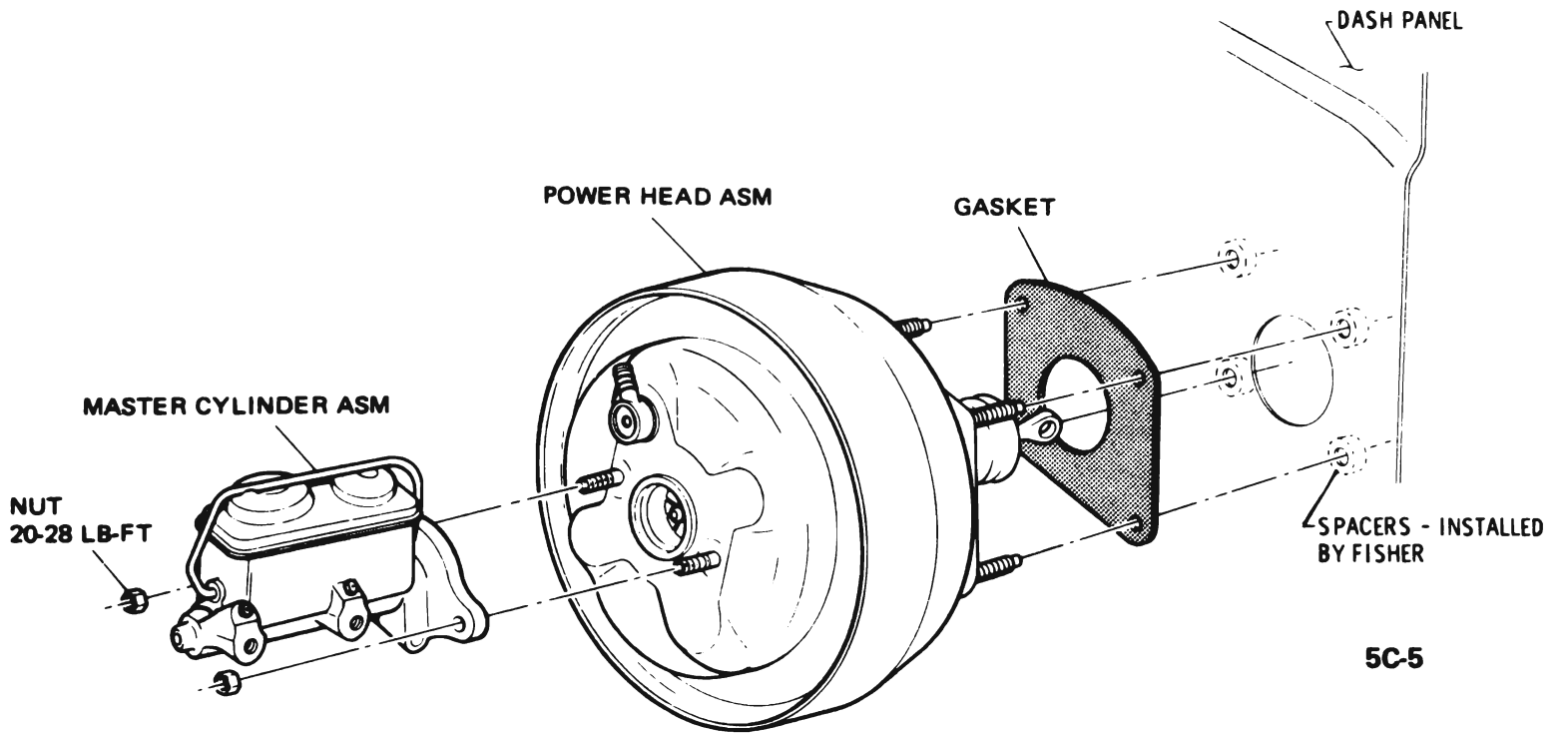

Figure 5C-5 Master Cylinder Mounting - B-C-E Car Power Brakes

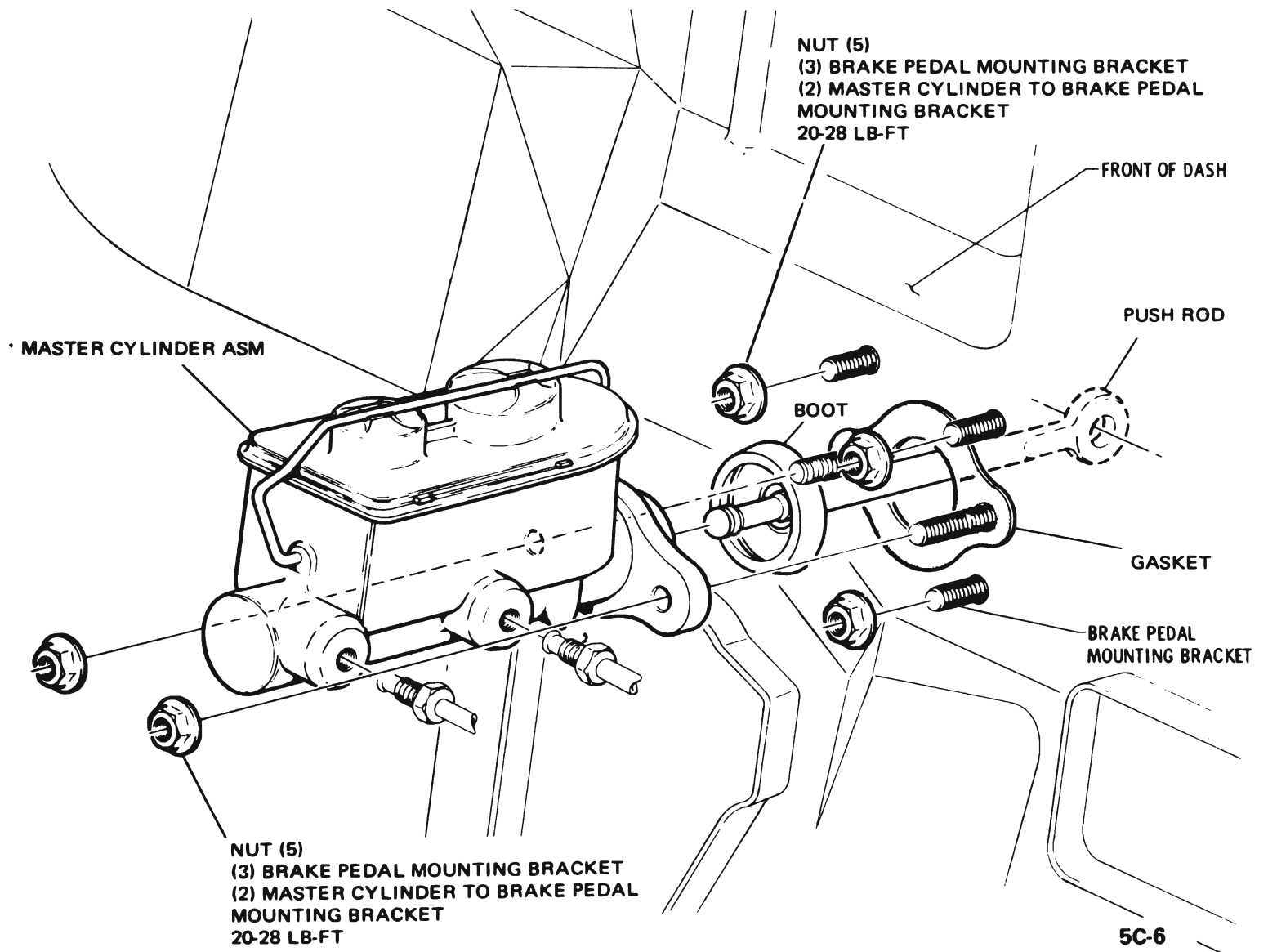

Figure 5C-6 Master Cylinder Mounting - A Car Manual Brakes

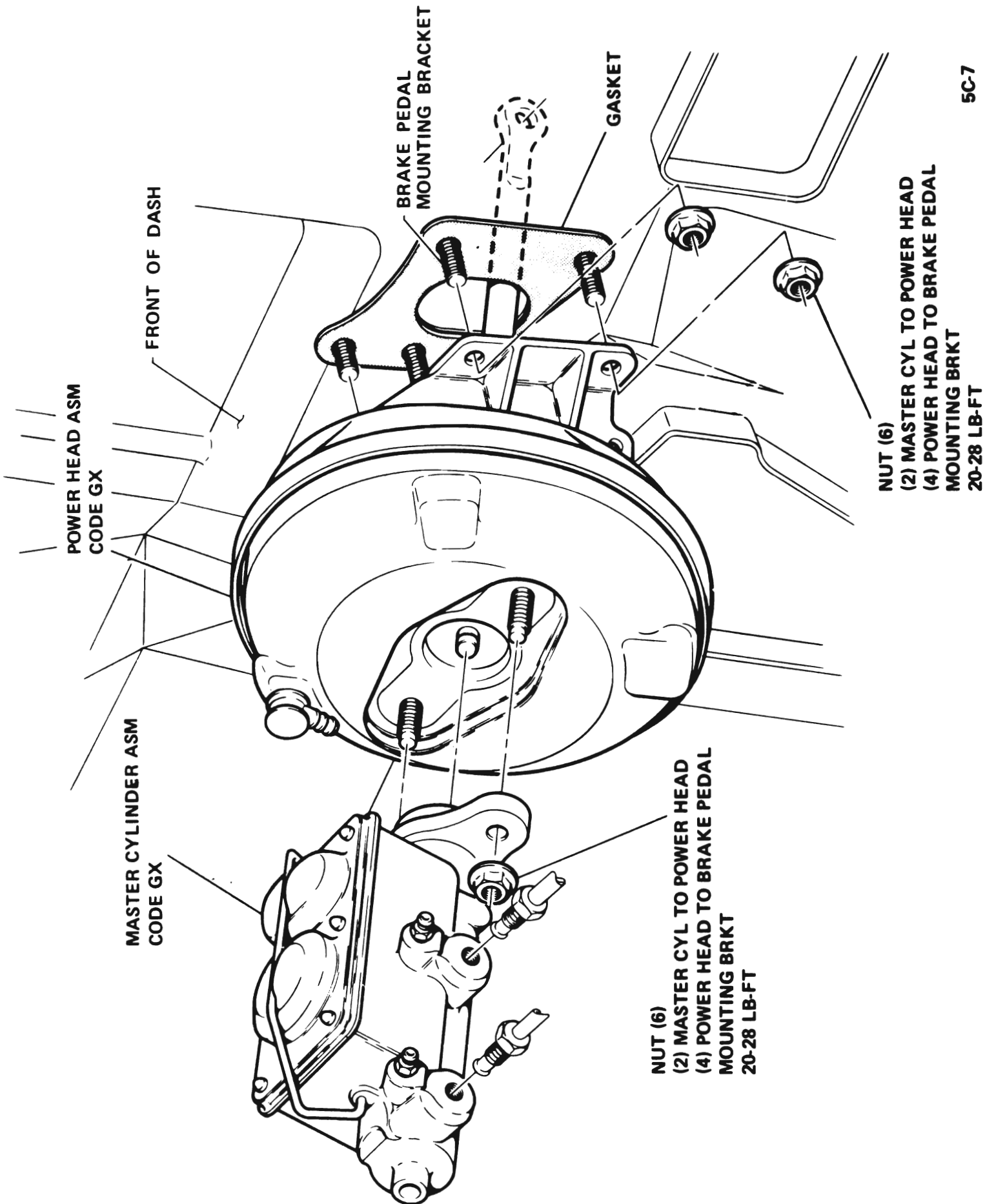

Figure 5C-7 Master Cylinder Mounting - A Car Power Brakes

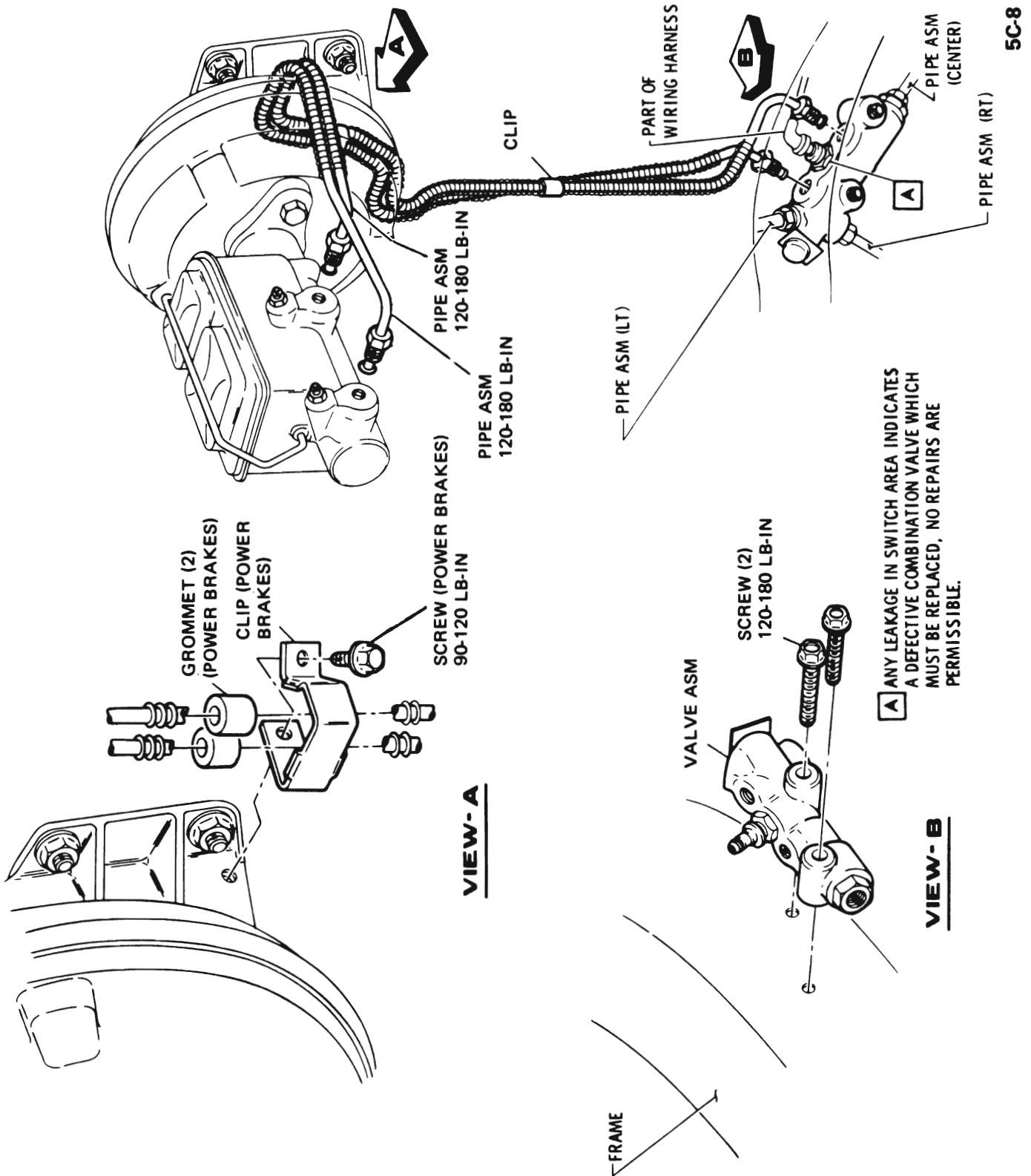

Figure 5C-8 Lines - Master Cylinder to Combination Valve