

# STEERING LINKAGES

## CONTENTS

Subject	Page No.
<b>DESCRIPTION AND OPERATION:</b>	
Description and Operation of Linkage .....	3C-31
<b>DIAGNOSIS:</b>	
Steering Linkage Trouble Diagnosis .....	3C-31
<b>MAINTENANCE AND ADJUSTMENTS:</b>	
Adjustment of Steering Linkage Idler Arm .....	3C-32
<b>MAJOR REPAIR:</b>	
Removal and Installation of Steering Linkage .....	3C-32
<b>SPECIFICATIONS:</b>	
Specifications .....	3C-34

## DESCRIPTION AND OPERATION

### DESCRIPTION OF STEERING LINKAGE

All Buicks use a parallelogram type steering linkage to connect both front wheels to the steering gear pitman arm. The right and left tie rods are attached to steering arms and to a forged intermediate rod by ball studs. The left end of the intermediate rod is supported by the pitman arm and the right end by an

idler arm which pivots on a support attached to the frame. The pitman and idler arms are always parallel to each other and move through symmetrical arcs. See Figure 3C-1.

The "A" Series with manual steering gear will be equipped with a shock absorber located between the pitman arm and the intermediate rod to reduce linkage shocks transmitted to the steering wheel. See Figure 3C-2.

## DIAGNOSIS

### TROUBLE DIAGNOSIS AND TESTING

CONDITION	TEST OR INSPECTION PROCEDURE
Steering linkage worn or insufficiently lubricated	Visual inspection of the joint and proper lubrication. If lubrication does not solve the problem, disassemble the joint and check the ball stud and tapered hole for wear. If necessary, replace the appropriate component as outlined in the Major Repair Section.
Steering linkage loose	Visual inspection of the linkage during operation to isolate the problem area. If necessary to replace the component, refer to the appropriate portion of the Major Repairs Section. If just loosely assembled, torque the proper specifications.

## MAINTENANCE AND ADJUSTMENTS

### ADJUSTMENT OF STEERING LINKAGE IDLER ARM

The Saginaw linkage requires proper location of the idler arm on its support so that the idler arm ball socket will be level with the pitman arm ball socket. The support must be threaded into the idler arm bushing until the distance from the center of the bolt hole to the top of the idler arm boss is as shown in Figure 3C- 3. When the idler arm is installed on the support, it must be free to rotate a minimum of 90 degrees in both directions from straight ahead.

The allowable lash is the idler arm and support assembly is 1/8" with a plus or minus 25 lbs. applied vertically at the intermediate rod end of the idler arm.

If the idler arm support is dismantled from the frame for other work, wire the support to the idler arm so that it cannot turn from its existing position and possibly change the toe-in of the front wheels.

See Front End Alignment Section for adjustment of tie rods to obtain proper "toe-in" of front wheels. See Figure 3C-1 for correct positioning of tie rod clamps.

## MAJOR REPAIR

When disconnecting any of the steering linkage ball studs, use puller J-5504 where possible. If puller will not work, use remover J-3295 and firmly support

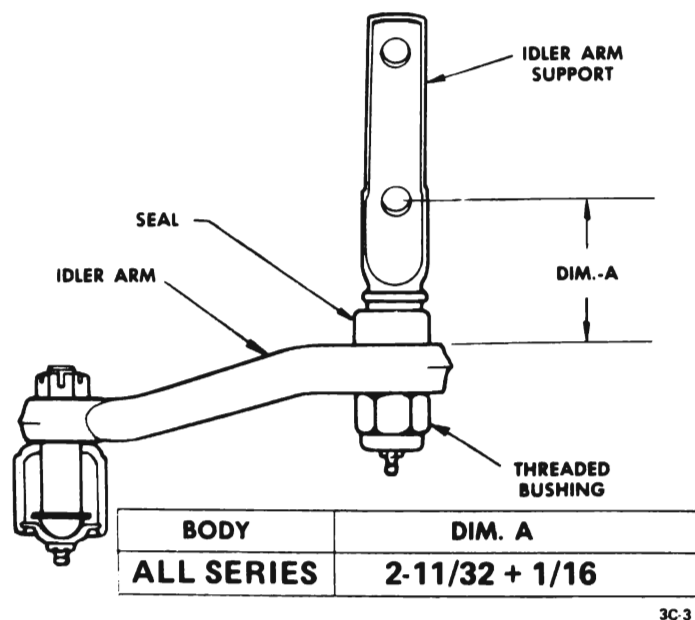

3C-3

Figure 3C-3 Idler Arm Mounting

the member from which the stud is being removed.

**CAUTION:** *If a joint is replaced, the tapered hole must be examined for elongation.*

## REMOVAL AND INSTALLATION OF TIE RODS

### Removal

1. Place vehicle on hoist.
2. Remove cotter pins from ball studs and remove castellated nut.
3. To remove outer ball stud, tap on steering arm at the rod end with a hammer, while using a heavy hammer, or similar tool, as a backing. If necessary, pull downward on tie rod to remove from steering arm.
4. Remove inner ball stud from intermediate rod, using same procedure as described in Steps 2 and 3.
5. To remove tie rod ends from tie rods, loosen clamp bolts and unscrew end assemblies.

Tie rod adjuster components often become rusted in service. In such cases, it is recommended that if the torque required to remove the nut from the bolt after breakaway exceeds 7 lb.ft., discard the nuts and bolts. Apply penetrating oil between the clamp and tube and rotate the clamps until they move freely. Install new bolts and nuts having the same part number to assure proper clamping at the specified nut torque.

### Installation

**CAUTION:** *Fasteners in the following steps are important attaching parts in that they could affect the performance of vital components and systems and/or could result in major repair expense. It must be replaced with one of the same part number, or with an equivalent part, if replacement becomes necessary. Do not use a replacement part of lesser quality or substitute design. Torque values must be used as specified during reassembly to assure proper retention of this part.*

1. If the tie rod ends were removed, lubricate the tie rod threads with EP chassis lube and thread ends of tie rod into the sleeve, making sure both ends are threaded an equal distance into the sleeve.

2. Make sure that threads on ball stud and in ball stud nuts are perfectly clean and smooth. No nicks on taper. Install seals on ball studs. If threads are not

clean and smooth, ball studs may turn in tie rod ends when attempting to tighten nut.

3. Install ball studs in steering arms and intermediate rod.

4. Install ball stud nuts and torque to specifications, then advance nuts just enough to insert cotter pins and install cotter pins. Lubricate tie rod ends.

5. Refer to torque specifications at rear of this section for correct torque values.

Before locking clamp bolts on the rods, make sure that the tie rod ends are in alignment with their ball studs (each ball joint is in the center of its travel). If the tie rod is not in alignment with the studs, binding will result.

6. Remove vehicle from hoist.

7. Adjust toe-in.

### REMOVAL AND INSTALLATION OF INTERMEDIATE ROD

#### Removal

1. Place vehicle on hoist.

2. Remove inner ends of tie rods from intermediate rod, as described under "Tie Rod - Removal".

3. Remove cotter pin and nut from intermediate rod ball stud attachment at pitman arm.

4. Detach intermediate rod from pitman arm. Shift steering linkage, as required, to free pitman arm from intermediate rod.

5. Remove cotter pin and nut from idler arm and remove intermediate rod from idler arm.

#### Installation

**CAUTION:** *Fasteners in the following steps are important attaching parts in that they could affect the performance of vital components and systems and/or could result in major repair expense. It must be replaced with one of the same part number, or with an equivalent part, if replacement becomes necessary. Do not use a replacement part of lesser quality or substitute design. Torque values must be used as specified during reassembly to assure proper retention of this part.*

1. Install intermediate rod to idler arm, making certain idler stud seal is in place, then install and tighten nut to specifications. Advance nut just enough to insert cotter pin and install pin.

2. Raise end of rod and install on pitman arm. Tighten nut to specifications, then advance nut just enough to insert cotter pin and install cotter pin.

3. Install tie rod ends to intermediate rod, as previously described under "Tie Rods". Lubricate tie rod ends.

4. Install ball stud nuts and tighten to specifications, then advance nut just enough to insert cotter pin and install cotter pin.

5. Refer to torque specifications at rear of this section for correct torque values.

6. Remove vehicle from hoist.

7. Adjust toe-in and align steering wheel.

### REMOVAL AND INSTALLATION OF IDLER ARM

#### Removal

1. Place vehicle on hoist.

2. Remove idler arm to two (2) frame nuts, washers, and bolts.

3. Remove cotter pin and nut from idler arm to intermediate rod ball stud.

4. Remove intermediate rod from idler arm by tapping intermediate rod with a hammer, using a heavy hammer as a backing.

5. Remove idler arm.

#### Installation

1. Position support against frame and secure with two (2) bolts, washers, and nuts. Install and tighten nuts to specifications.

2. Install intermediate rod to idler arm, making certain seal is on stud. Install and tighten nut to specifications.

3. Advance nut just enough to insert cotter pin and install cotter pin.

4. Refer to torque specifications at rear of this section for correct torque values.

5. Remove vehicle from hoist.

### REMOVAL AND INSTALLATION OF PITMAN ARM

#### Removal

1. Place vehicle on hoist.

2. Remove cotter pin from pitman arm ball stud and remove nut.

3. Remove intermediate rod from pitman arm by tapping on side of rod or arm in which the stud mounts with a hammer, while using a heavy hammer, or similar tool, as a backing. Pull down on intermediate rod to remove from stud.

4. Remove pitman arm nut and lock washer from pitman shaft and mark relation of arm position to shaft.

5. Remove pitman arm with Tool J-6632. Do not hammer on puller.

### Installation

**CAUTION:** *Fasteners in the following steps are important attaching parts in that they could affect the performance of vital components and systems and/or could result in major repair expense. It must be replaced with one of the same part number, or with an equivalent part, if replacement becomes necessary. Do not use a replacement part of lesser*

*quality or substitute design. Torque values must be used as specified during reassembly to assure proper retention of this part.*

with one of the same part number, or with an equivalent part, if replacement becomes necessary. Do not use a replacement part of lesser quality or substitute design. Torque values must be used as specified during reassembly to assure proper retention of this part.

1. Install pitman arm on pitman shaft, lining up the marks made upon removal.

2. Install pitman shaft nut and lock washer. Torque to specifications.

3. Position intermediate rod to pitman arm. Install nut. Torque to specifications. Continue to tighten nut enough to install cotter pin.

4. Refer to torque specifications at rear of this section for correct torque values.

5. Remove vehicle from hoist.

## SPECIFICATIONS

### STEERING LINKAGE SPECIFICATIONS

#### Tightening Specifications

Use a reliable torque wrench to tighten the parts listed to insure proper tightness without straining or distorting parts. These specifications are for clean and lightly-lubricated threads only. Dry or dirty threads produce increased friction which prevents accurate measurements of tightness.

#### Lower Series

Part	Location	Torque Lb.Ft.
Nut	Steering Arm to Tie Rod End .....	30-40 Lb.Ft. With 45 Lbs. Max.
Nut	Tie Rod Clamp Nuts .....	19-24
Nut	Tie Rod to Intermediate Rod .....	30-50 Lb.Ft. With 55 Lbs. Max.
Nut	Pitman Arm to Intermediate Rod .....	30-40 Lb.Ft. With 45 Lbs. Max.
Nut	Pitman Arm to Steering Gear .....	160-210
Nut	Idler Arm to Intermediate Rod .....	30-50 Lb.Ft. With 55 Lbs. Max.
Nut	Idler Arm to Frame .....	40-55
Bolt	Idler Arm to Frame .....	55-70

## Upper Series

Part	Location	Torque Lb.Ft.
Nut	Steering Arm to Tie Rod End .....	30-40 Lb.Ft.
Nut	Tie Rod Clamp Nuts .....	19-24
Nut	Tie Rod to Intermediate Rod .....	50-70 Lb.Ft. With 85 Lbs. Max.
Nut	Pitman Arm to Intermediate Rod .....	40-50 Lb.Ft. With 55 Lbs. Max.
Nut	Pitman Arm to Steering Gear .....	60-210
Nut	Idler Arm to Intermediate Rod .....	35-45 Lb.Ft. With 50 Lbs. Max.
Nut	Idler Arm to Frame .....	40-55
Bolt	Idler Arm to Frame .....	55-70

Where torques shown are, for example 50 to 70 lb.ft., torque with 85 lb.ft. maximum to insert cotter pin. Do not back off nuts to obtain cotter pin insertion.

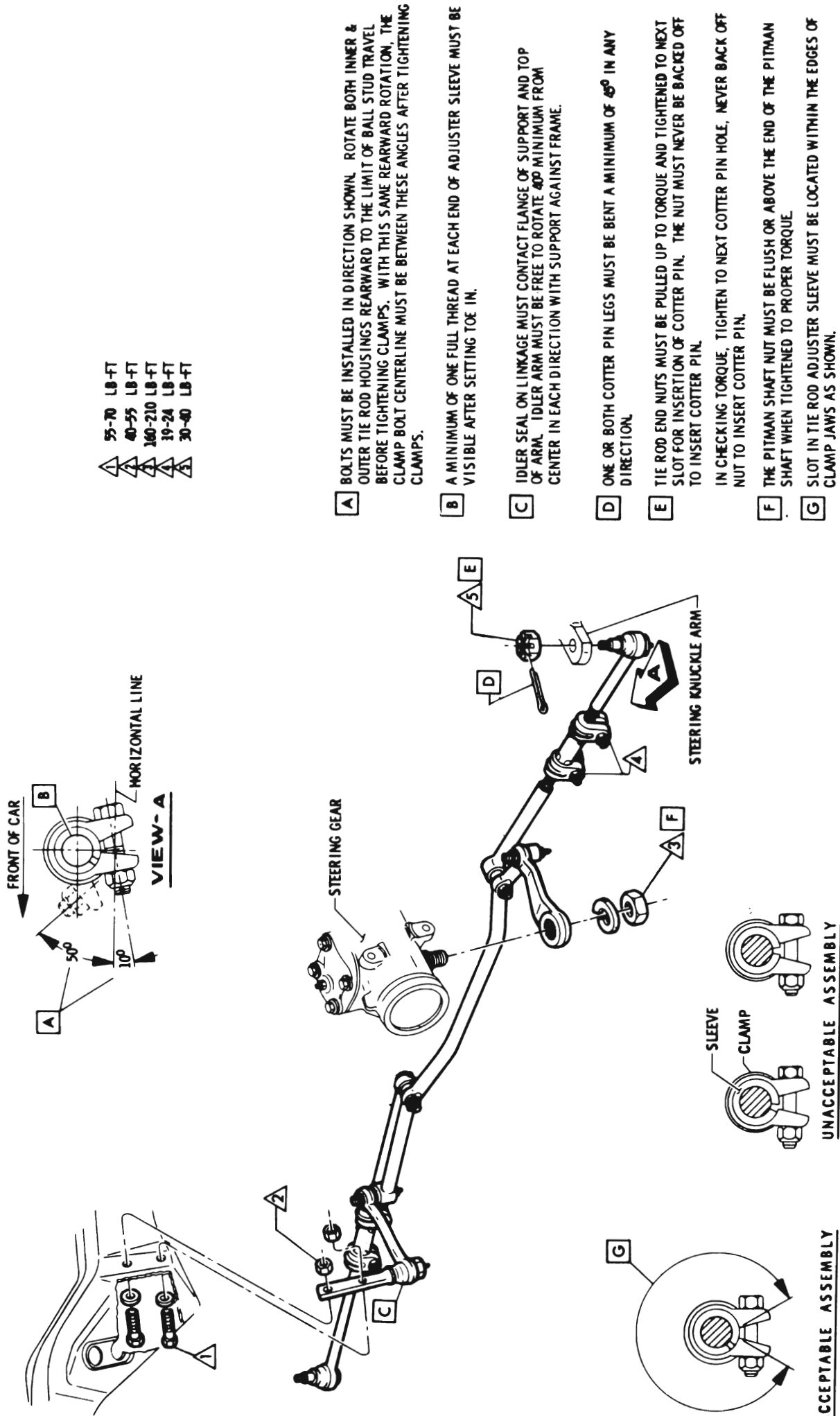
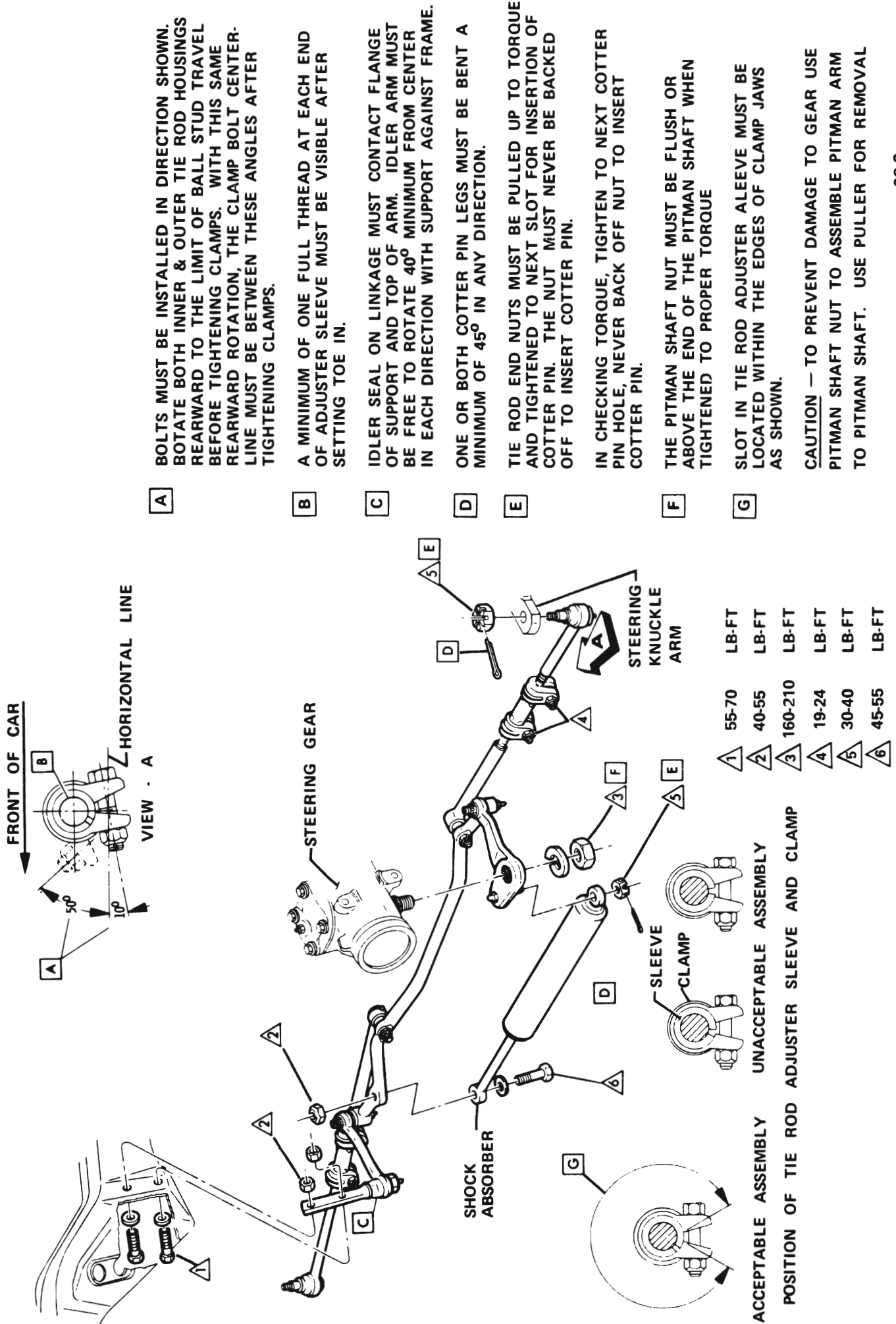

Figure 3C-1 Typical Steering Linkage



- A** BOLTS MUST BE INSTALLED IN DIRECTION SHOWN. ROTATE BOTH INNER & OUTER TIE ROD HOUSINGS REARWARD TO THE LIMIT OF BALL STUD TRAVEL BEFORE TIGHTENING CLAMPS. WITH THIS SAME REARWARD ROTATION, THE CLAMP BOLT CENTERLINE MUST BE BETWEEN THESE ANGLES AFTER TIGHTENING CLAMPS.
  - B** A MINIMUM OF ONE FULL THREAD AT EACH END OF ADJUSTER SLEEVE MUST BE VISIBLE AFTER SETTING TOE IN.
  - C** IDLER SEAL ON LINKAGE MUST CONTACT FLANGE OF SUPPORT AND TOP OF ARM. IDLER ARM MUST BE FREE TO ROTATE 40° MINIMUM FROM CENTER IN EACH DIRECTION WITH SUPPORT AGAINST FRAME.
  - D** ONE OR BOTH COTTER PIN LEGS MUST BE BENT A MINIMUM OF 45° IN ANY DIRECTION.
  - E** TIE ROD END NUTS MUST BE PULLED UP TO TORQUE AND TIGHTENED TO NEXT SLOT FOR INSERTION OF COTTER PIN. THE NUT MUST NEVER BE BACKED OFF TO INSERT COTTER PIN.
  - F** IN CHECKING TORQUE, TIGHTEN TO NEXT COTTER PIN HOLE, NEVER BACK OFF NUT TO INSERT COTTER PIN.
  - G** THE PITMAN SHAFT NUT MUST BE FLUSH OR ABOVE THE END OF THE PITMAN SHAFT WHEN TIGHTENED TO PROPER TORQUE
- SLOT IN TIE ROD ADJUSTER SLEEVE MUST BE LOCATED WITHIN THE EDGES OF CLAMP JAWS AS SHOWN.
- CAUTION — TO PREVENT DAMAGE TO GEAR USE PITMAN SHAFT NUT TO ASSEMBLE PITMAN ARM TO PITMAN SHAFT. USE PULLER FOR REMOVAL

Figure 3C-2 "A" Series Manual Steering Linkage