

# SIGNAL SYSTEMS

## CONTENTS

Subject	Page No.
<b>DESCRIPTION AND OPERATION:</b>	
Horns and Control Circuit .....	1F-80
Directional Signal and Hazard Warning Flasher Systems .....	1F-81
Cornering Lights .....	1F-82
Backup Lights .....	1F-82
Stop Lights .....	1F-82
<b>DIAGNOSIS:</b>	
Turn Signal and Hazard Warning Lamp .....	1F-82
Cornering Lamp .....	1F-84
Backup Lamp .....	1F-85
Stop Lamp .....	1F-86
<b>MAINTENANCE AND ADJUSTMENTS:</b>	
Voltage Test at Horn .....	1F-86
Adjustment of Horns .....	1F-86
Adjustment of Stoplight and Cruise Control Switches .....	1F-91
<b>MAJOR REPAIR: (Not Applicable)</b>	
<b>SPECIFICATIONS:</b>	
Signal Systems .....	1F-90

## DESCRIPTION AND OPERATION

### HORNS AND CONTROL CIRCUIT

#### Horns and Relay

The horns which are located at the left front of the engine compartment are operated simultaneously by a horn relay that is controlled by the horn switch at the top of the steering column. They are installed in matched sets consisting of one high pitch and one low pitch horn and have an adjustment feature. See Figure 1F-1.

The horn relay is an electrical switch which closes the circuit between the battery and the horns when the push button is pressed and opens the circuit when the button is released. The relay permits control of the horns with a small amount of current passing through the horn switch contacts.

When the horn switch contacts are closed, a small amount of current flows through the relay winding to ground at the horn switch contact. This magnetizes the relay core which attracts the flat steel relay

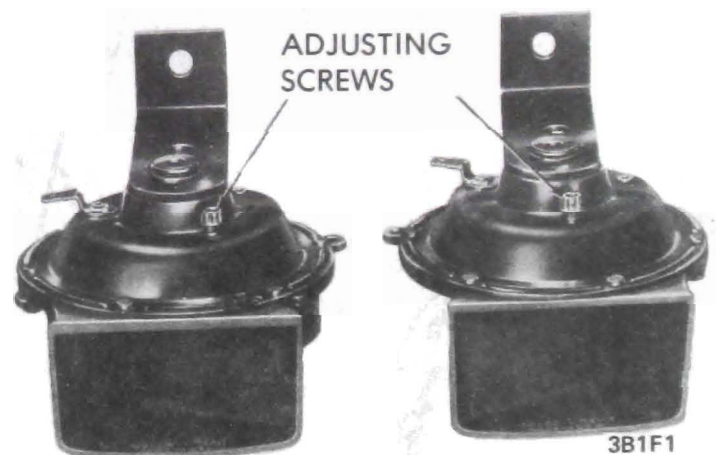

Figure 1F-1 Typical Matched Horn Set

armature. The armature has a contact point which makes contact with a stationary point to close the horn circuit. When horn switch is released, current stops flowing through relay winding so that the core loses its magnetism; the armature spring then causes contact points to be separated.

#### Horn Relay Ground Circuit

The steering wheel has an acuator bar mounted across the steering wheel. Fastened to the base of the

actuator bar, but insulated from it, is a contact plate which is "hot" at all times. When the actuator bar is rocked, the contact plate contacts a ground plate on the steel hub of the steering wheel to ground the horn relay winding, close the relay contacts, and blow the horns. When the actuator bar is released, two springs move the actuator bar and contact plate assembly clear of the ground plate.

Current is supplied to the contact plate by a spring-loaded brush which rides on the contact ring located at the upper end of the steering column. A wire attached to the contact ring runs down the steering column jacket and out under the instrument panel. The wire from the horn relay connects at this point.

## DIRECTION SIGNAL AND HAZARD WARNING SYSTEMS

### Direction Signal and Indicator

The front direction signal light is produced by the 32 CP filament in the dual purpose bulb mounted in the front parking lamp. The rear direction signal light is produced by the 32 CP filament in the bulb of the rear lamp assembly. This filament also serves as a stoplight.

When the ignition switch is turned on and the direction signal switch is manually operated to indicate a turn, the front and rear signal lights and the front side marker lamps flash on and off on the side of car for which a turn is indicated. The flashing of signal lights is caused by a flasher which is connected into the proper signal circuit by contacts made in the direction switch when switch is set for a turn.

When lights are turned on, the side marker will flash opposite the signal lights.

When the direction signal lights are flashing, a signal indicator bulb on the instrument panel also flashes. These indicator lights are connected to the front half of the direction signal circuit only.

### Direction Signal Switch Operation

The direction or turn signal switch is mounted in a housing at the upper end of the steering column mast jacket, just below the steering wheel. The turn signal actuating plate (on the inner end of the control lever) is mounted to a pivot just over and contacting the turn signal switch. This switch is integral with an eight wire harness (about 1 1/2 feet long) and a multiple connector. The switch and a spring-loaded horn brush are both mounted in the switch plate base.

A plastic cancelling cam assembly fits over the steer-

ing shaft; the lower end of the cam contacts the steering shaft upper bearing and the upper face of the cam engages the steering wheel hub, causing the cam to turn with the wheel. At the outer edge of the cam there is a horn contact ring in a position to depress the horn brush. See Figure 1F-2.

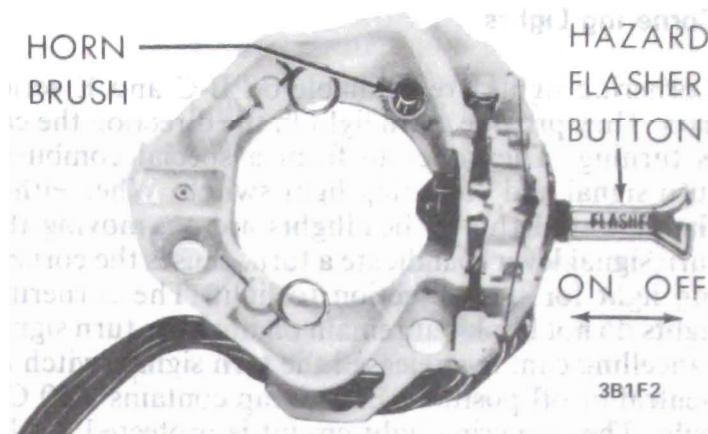

Figure 1F-2 Direction Signal and Hazard Warning Flasher Switch Assembly

Whenever the control lever is in either turn position, a projection on the cancelling cam contacts a spring on the actuating plate once per revolution of the steering wheel. Rotation of the cam in one direction simply snaps the spring but does not move the actuating plate; rotation in the other direction causes the actuating plate to be pushed back to neutral position.

### Direction Signal and Hazard Warning Flasher Circuits

When signaling for a turn, the selected direction signal lights are supplied with current from the ignition switch, through a "DIR. SIG." fuse, through a direction signal flasher mounted on a spring clip on the parking brake bracket, and through standard contacts in the direction signal switch.

When the hazard warning flasher is turned on, however, the normal direction signal supply is disconnected at the direction signal switch and a new supply circuit is connected into the switch directly from the battery. This new hazard flasher circuit comes through a stop and hazard flasher fuse and through a special heavy duty flasher mounted on the fuse block to the direction signal switch, which now has all contacts closed.

### Hazard Warning Flasher

The hazard warning system, when turned on, causes all turn signal lamps to flash simultaneously. This system makes use of the regular turn signal wiring and light bulbs, but has a separate supply wire, flasher unit and off-on switch. This makes it possible, to operate the system even though the ignition switch

and doors are locked. The system is activated by pushing in on the switch knob which is located just below the steering wheel on the right side of the steering column. The hazard flasher system should be turned off before the car is driven.

### Cornering Lights

Cornering lights are available on B-C and E series cars. They provide extra light in the direction the car is turning. They operate from a special combined turn signal and cornering light switch. When either the parking lights or headlights are on, moving the turn signal lever to indicate a turn, causes the cornering light for that direction to light. The cornering lights do not blink but remain on until the turn signal cancelling cam has released the turn signal switch to neutral or off position. Each lamp contains a 50 CP bulb. The cornering light circuit is protected by the 20 amp taillight fuse.

### Backup Lights

*On manual transmission cars*, the back-up light switch is mounted on the upper side of the steering column mast jacket in approximately the same location as the combined neutral-start back-up light switch on automatic transmission cars. The manual back-up light switch has a tang that fits into a slot in the shift tube. When the transmission is shifted into reverse, the shift tube rotates, moving the tang to the left, closing the back-up switch contacts.

*An additional set of contacts have been added to the neutral start switch* to prevent the seat belt warning alarm from coming on except in gears R, 1st, 2nd, 3rd and 4th, for manual transmission cars. For automatic transmission cars the additional set of contacts have been added to the neutral start and back up lamp switch to prevent the alarm from coming on in gears R, D, L-1 and L-2.

To check for proper operation of the back-up light switch, turn on the ignition switch, place the shift lever in reverse, and make sure the back-up lights are

lit. Then place the shift lever in neutral and make sure the back-up lights are out. Next, place the shift lever in second gear and make sure the lights are not lit. The switch mounting screw holes are slotted slightly, allowing some adjustment, if necessary.

*On all column shift automatic transmission cars*, the back-up light switch is combined with the neutral start switch. It is mounted on the steering column under the instrument panel. The switch is actuated by the transmission control shaft.

On cars with automatic transmission and console shift, the back-up light switch is combined with the neutral start switch. It is mounted on the steering column under the instrument panel. When the neutral-start portion of the switch is correctly timed, the back-up portion is properly timed automatically. Slotted mounting screw holes permit sidewise movement of the switch for proper timing.

### Stop Lights

Each rear lamp assembly contains a 32-3 CP bulb which is used as a combination tail, stop, and direction signal light. The tail lights are controlled by the lighting switch and the circuit is protected by a fuse on the fuse block.

The stop lights are controlled by a mechanical switch mounted on the brake pedal bracket. This spring loaded switch makes contact whenever the brake pedal is applied. When the brake pedal is released, it depresses the switch plunger to open the contacts and turn the brake lights off.

The direction signal switch is in the circuit, so the stop lights may be flashing or constant, depending on the position of the switch. The stop light circuit is protected by a fuse mounted on the fuse block.

The combination tail, stop and directional signal lamp bulb sockets except on "B" Wagon are "twist lock" type sockets. Since the position of the bulb filaments is important in the rear lamps, these sockets have been provided with a tongue and groove index to insure correct positioning.

## DIAGNOSIS

### TURN SIGNAL AND HAZARD WARNING LAMP

Condition	Possible Cause	Correction
Turn signals inoperative one side	1. Bulb(s) burnt out (Flasher cannot be heard)	1. Turn hazard warning system on. If one or more bulbs are inoperative replace necessary bulbs.

- |                                     |  |
|-------------------------------------|--|
| 2. Open wiring or ground connection | 1. Turn Hazard warning system on. If one or more bulbs are inoperative, use test lamp and check circuit at lamp socket. If test lamp lights, repair open ground connection. If not, repair open wiring between bulb socket and turn signal switch. |
|-------------------------------------|--|

- |   |   |
|---|---|
| 3. Improper bulb or defective turn signal switch. | 1. Turn hazard warning system on. If all front and rear lamps operate, check for improper bulb (1034 instead of 1157). If bulbs are OK, replace defective turn signal switch. |
|---|---|

- |  |   |
|--|---|
| 4. Short to ground.<br>(Flasher can be heard,<br>no bulbs operate) | 1. Locate and repair short to ground by disconnecting front and rear circuits separately. |
|--|---|

**Turn signals inoperative**

- |                           |   |
|---------------------------|---|
| 1. Blown turn signal fuse | 1. Turn hazard warning system on. If all lamps operate, replace blown fuse. If new fuse blows, repair short to ground between fuse and lamps. |
|---------------------------|---|

- |  |   |
|--|---|
| 2. Defective flasher<br>(Located behind instrument panel near steering column) | 1. If turn signal fuse is OK and hazard warning system will operate lamps, replace defective turn signal flasher. |
|--|---|

- |                     |  |
|---------------------|--|
| 3. Loose connection | 1. Secure steering column connector.<br><br>If necessary, check purple wire terminals in connector with test lamp. If test lamp lights only on one side of connector, clean or tighten connector contacts. |
|---------------------|--|

**Hazard warning lamps inoperative**

- |                           |  |
|---------------------------|--|
| 1. Blown stop-hazard fuse | 1. Switch turn signals on. If lamps operate, replace stop-hazard fuse if blown. If new fuse blows, repair short to ground. (Could be in stop light circuit). |
|---------------------------|--|

- |   |   |
|---|---|
| 2. Defective hazard warning flasher. (Located on fuse panel). | 1. If stop-hazard fuse is OK, switch turn signals on. If lamps operate, replace defective hazard flasher. |
|---|---|

- |  |   |
|--|---|
| 3. Open in wiring or defective turn signal switch. | 1. Using test lamp, check brown wire in turn signal steering column connector. If lamp does not light on either side of |
|--|---|

connector, repair open circuit between flasher and connector. If lamp lights only on feed side of connector, clean connector contacts. If lamp lights on both sides of connector, replace defective turn signal switch assembly.

### CORNERING LAMP

Condition	Possible Cause	Correction
One lamp inoperative	1. Loose connection	1. Secure connector near lamp.
	2. Burnt out bulb	1. Replace burnt out bulb.
	3. Open ground connection	1. If bulb is known good and test lamp lights at connector near lamp, repair open ground connection
	4. Open in wiring	1. If test lamp lights on both sides of steering column connector, repair open wiring between connector and lamps. If not, check for open connection in connector.
	5. Defective turn signal switch	1. If test lamp lights at brown wire terminals of steering column connector, but not at gray or black/white strip wire terminals, replace turn signal switch.
Both lamps inoperative	1. Blown tail light fuse	1. If tail lamps do not light, replace tail light fuse if blown. If new fuse blows, repair short to ground between fuse and lamps.
	2. Loose connection	1. Secure all connectors at light switch and steering column.
	3. Open in wiring	1. If tail lamps light, check brown wire at steering column connector with test lamp. If test lamp lights on lamp side of connector only, repair terminal. If tail lamps do not light, check for open wiring between light switch and battery.
	4. Defective turn signal switch.	1. If tail lamps light and test lamp lights on both sides

of steering column connector, replace turn signal switch.

- |                           |   |
|---------------------------|---|
| 5. Defective light switch | 1. If tail lamps do not light and test lamp lights at light switch terminal No. 5 but not at No. 4, replace light switch. |
|---------------------------|---|

### BACK-UP LAMP

Condition	Possible Cause	Correction
One lamp inoperative or intermittent	1. Loose or burnt out bulb	1. Secure or replace bulb.
	2. Loose connection	1. Tighten connectors.
	3. Open ground connections	1. Repair bulb ground circuit.
Both lamps inoperative or intermittent.	1. Neutral start switch misadjusted (Open when shift lever is in reverse position)	1. Readjust neutral start switch.
	2. Loose connection or open circuit	1. Secure all connectors. If OK, check continuity of circuit from fuse to lamps with test lamp. If lamp does not light on either side of fuse, correct open circuit from battery to fuse.
	3. Blown fuse	1. Replace fuse. If new fuse blows, repair short to ground in circuit from fuse through neutral start switch to back-up lamps.
	4. Defective neutral start switch	1. With ignition on, check switch terminals in back-up position with test lamp. If lamp lights at pink wire terminal but not at light green wire terminal, replace neutral start switch.
	5. Defective ignition switch	1. If test lamp lights at ignition switch battery terminal but not at output terminal, replace ignition switch.
Lamp will not turn off	1. Neutral start switch misadjusted (closed when shift lever is not in reverse position)	1. Readjust neutral start switch

## STOP LIGHTS

Condition	Possible Cause	Correction
One bulb inoperative	1. Bulb burnt out.	1. Replace bulb.
One side inoperative	1. Loose connection, open wiring or defective bulbs	1. Turn on directional signal. If lamp does not operate, check bulbs. If bulbs are OK, secure all connections. If lamp still does not operate, use test lamp and check for open wiring.
	2. Defective directional signal switch or cancelling cam	1. If lamp will operate by turning directional signal on, the switch is not centering properly during cancelling operation. Replace defective cancelling cam or directional signal switch.
All inoperative	1. Stop-hazard fuse blown	1. Replace fuse. If new fuse blows, repair short to ground in circuit between fuse and lamps.
	1. Stop-switch misadjusted or defective	1. With brake pedal depressed, check white wire terminal in steering column connector with test lamp. If lamp does not light, check stop switch for proper adjustment. If adjustment is OK, replace stop switch.
Will not turn off	1. Stop switch misadjusted or defective.	1. Readjust switch. If switch still malfunctions, replace.

## MAINTENANCE AND ADJUSTMENTS

## VOLTAGE TEST AND ADJUSTMENT OF HORNS

## Voltage Test at Horn

An improperly-operating horn and its wiring circuit can be tested by connecting a voltmeter between the horn terminal and ground and noting the voltage while the horn button is pressed. The voltage at the horn gives an indication of the cause of trouble as follows:

1. No voltage indicates trouble in horn button, relay, wiring or ground.

2. Less than 9 volts indicates resistance in wiring or excessive current draw due to short circuit in horn.

3. Voltage between 9 and 11 volts indicates that wiring is okay. Look for sticking or improper adjustment of horn.

4. Voltage above 11 indicates improper adjustment or open circuit in horn due to broken coil lead.

## Adjustment of Horns

1. Remove horn from car. See Figures 1F-3, 1F-4 and 1F-5.

3B1F3

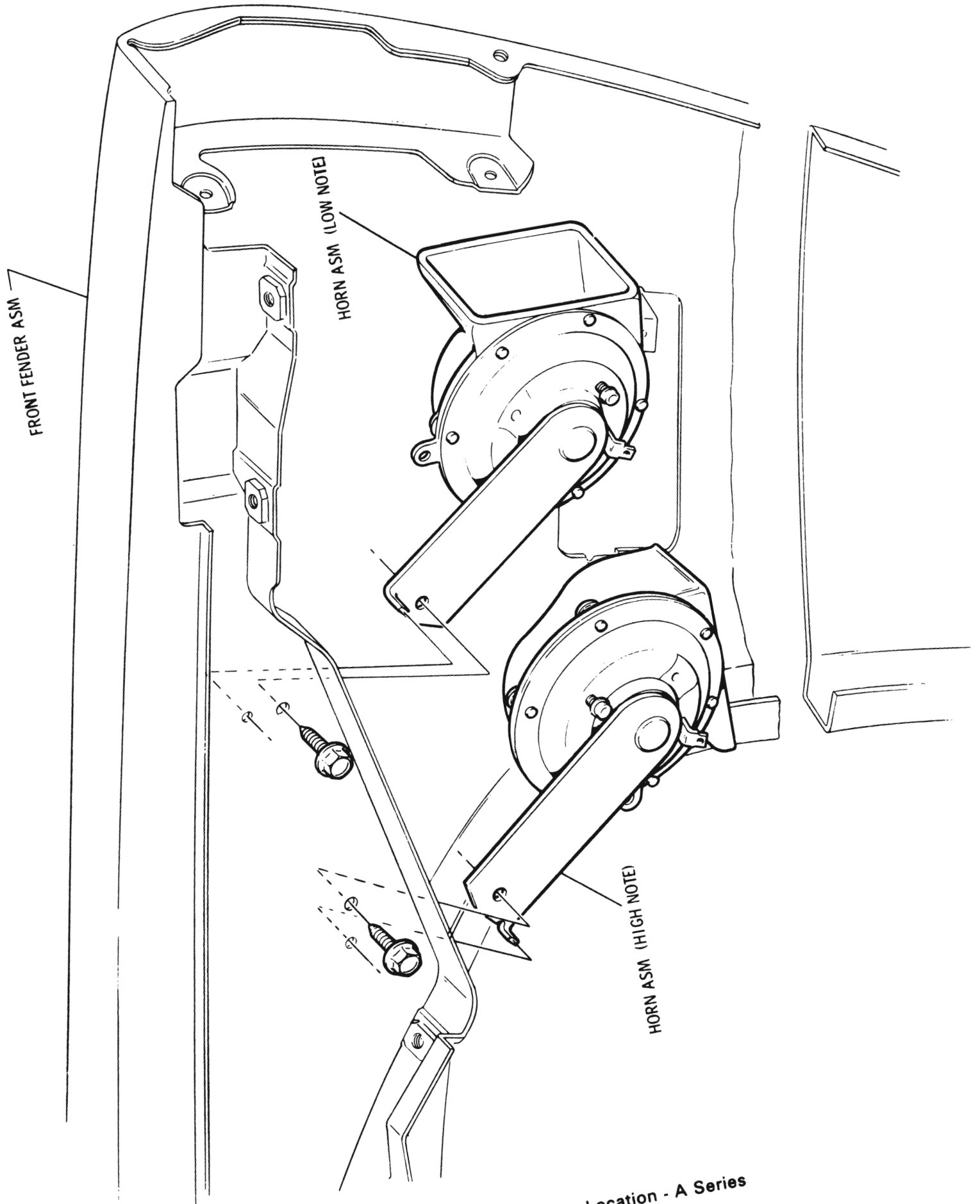
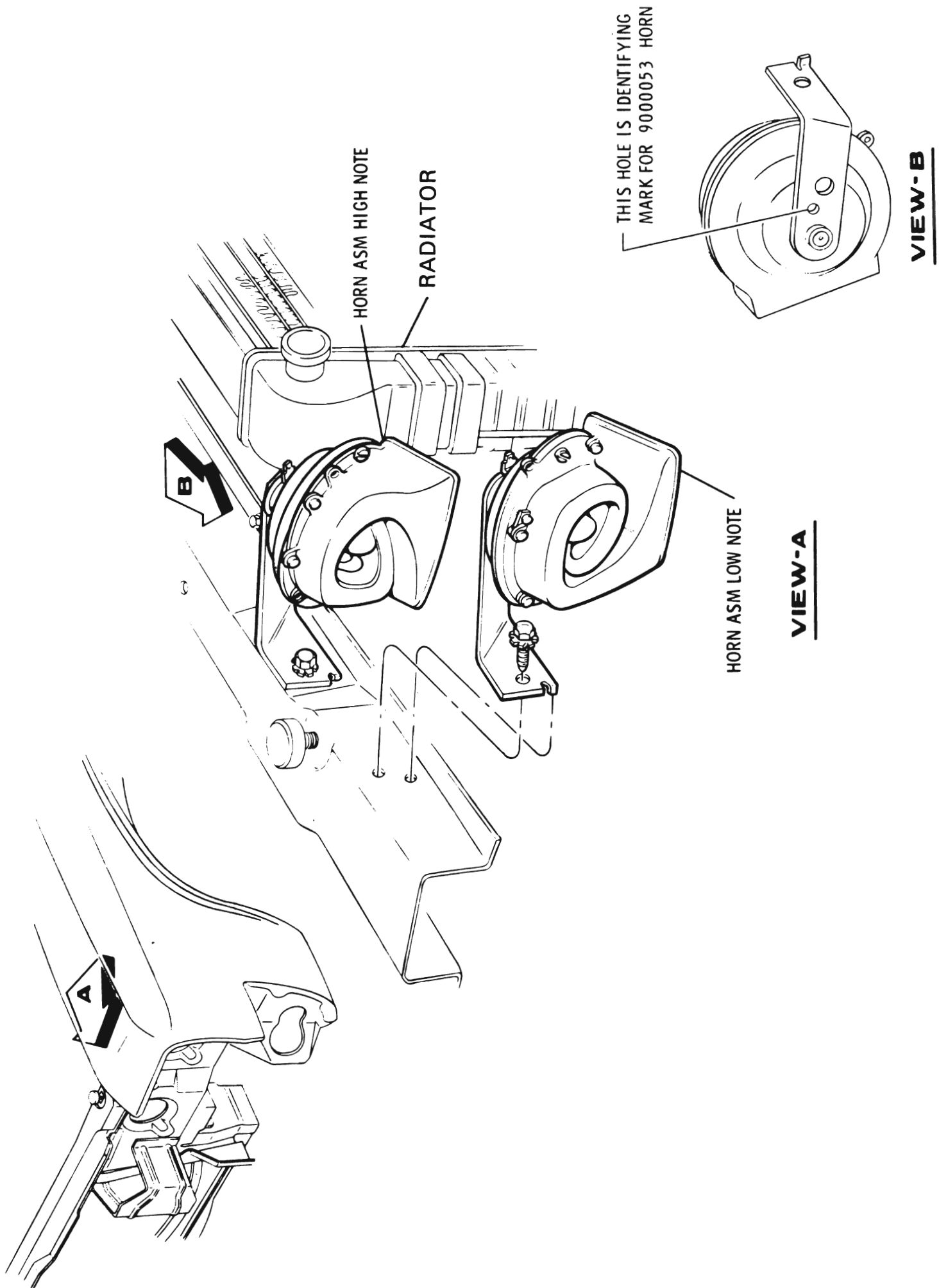

Figure 1F-3 Horn Location - A Series





3B1F4

Figure 1F-4 Horn Location - B-C-E Series

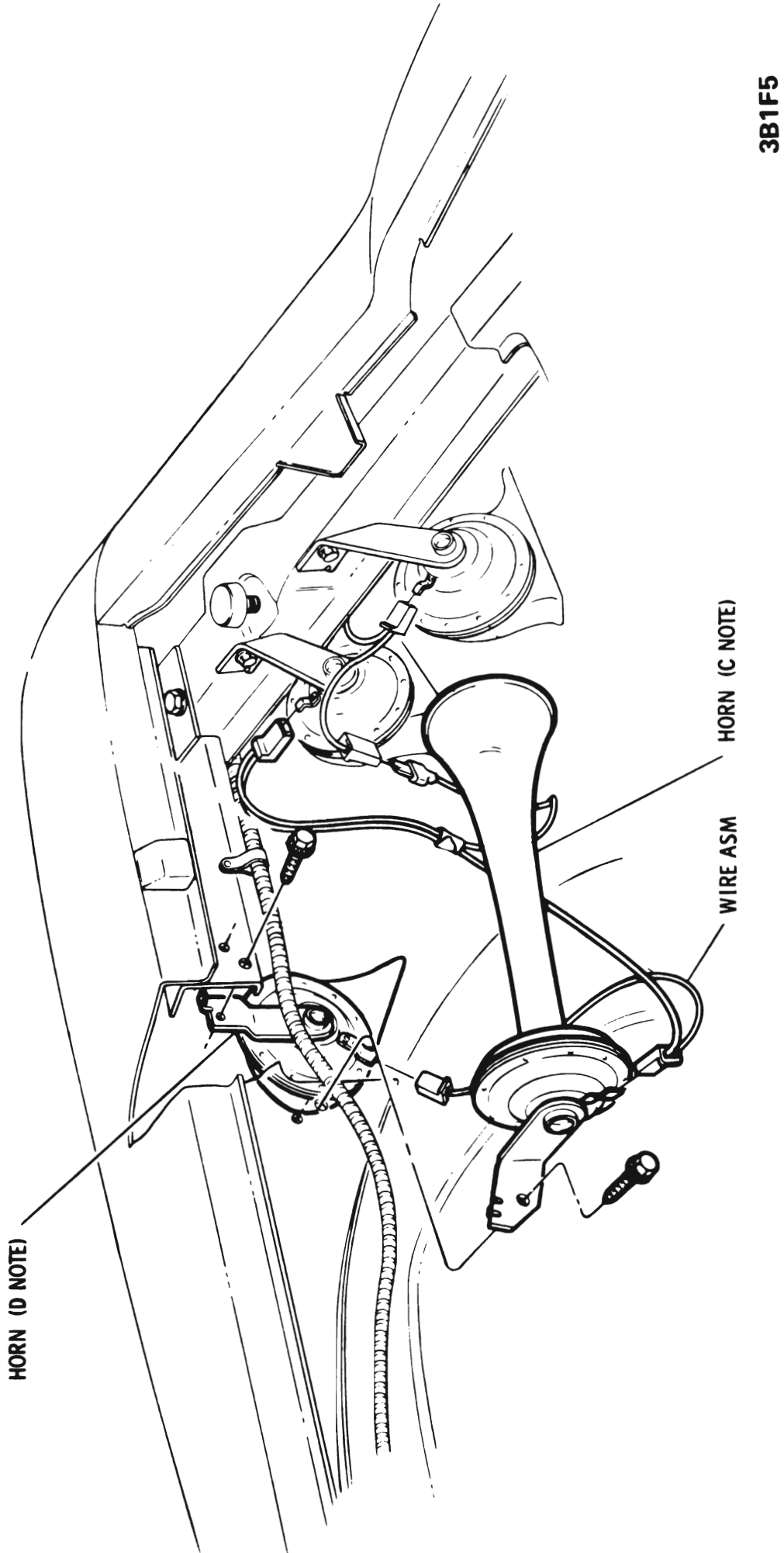

Figure 1F-5 Horn Location - Four Note Horns

2. Connect an ammeter in series with horn and a fully-charged 12-volt battery to measure current draw while horn is blowing. Current draw for each horn (either high or low note) should be between 4.5 and 5.5 amperes at 12.0 volts.

3. Adjust to specified current draw, if necessary, by turning adjusting screw clockwise to decrease or counterclockwise to increase current draw. Turn only 1/4 of a turn at a time. If adjustment loosens screw excessively, it may be staked with a prick punch. Increasing the current draw increases the horn volume. Too much current will

cause a high cut-in voltage which will cause a sputtering sound and may cause horn to stick in cold weather.

4. After each horn has been adjusted individually, sound both horns together to check for proper blend of tone. If adjustment does not provide a satisfactory tone, horn contacts are pitted, making horn replacement necessary.

5. With horns reinstalled on car, connect a voltmeter between each horn terminal and ground to check voltage while both horns are blowing. This should be between 9 and 11 volts.

## SPECIFICATIONS

### SIGNAL SYSTEMS SPECIFICATIONS

Stop Light Switch, Type .....	Mechanical
Stop Light Switch, Location .....	Pedal Mounting Bracket
Direction Signal Switch, Make .....	Delco-Remy
Direction Signal Flasher, Make .....	Melrane and Tung-Sol
Location .....	I.P. Wiring Harness
For 2-32 CP Lamp Load .....	491160
Flash Rate, Cycles per Min. ....	55 to 135
Hazard Warning Flasher (Heavy Duty) .....	491391
Lamp Bulbs - No. and Candle Power .....	See Lamp Chart
Direction Signal and Stop Light Fuse .....	See Lamp and Fuse Chart
Horn - Make and Type .....	Delco-Remy, Solenoid
Horn Amperage Draw at 12 Volts (Either Horn) .....	4.5 to 5.5

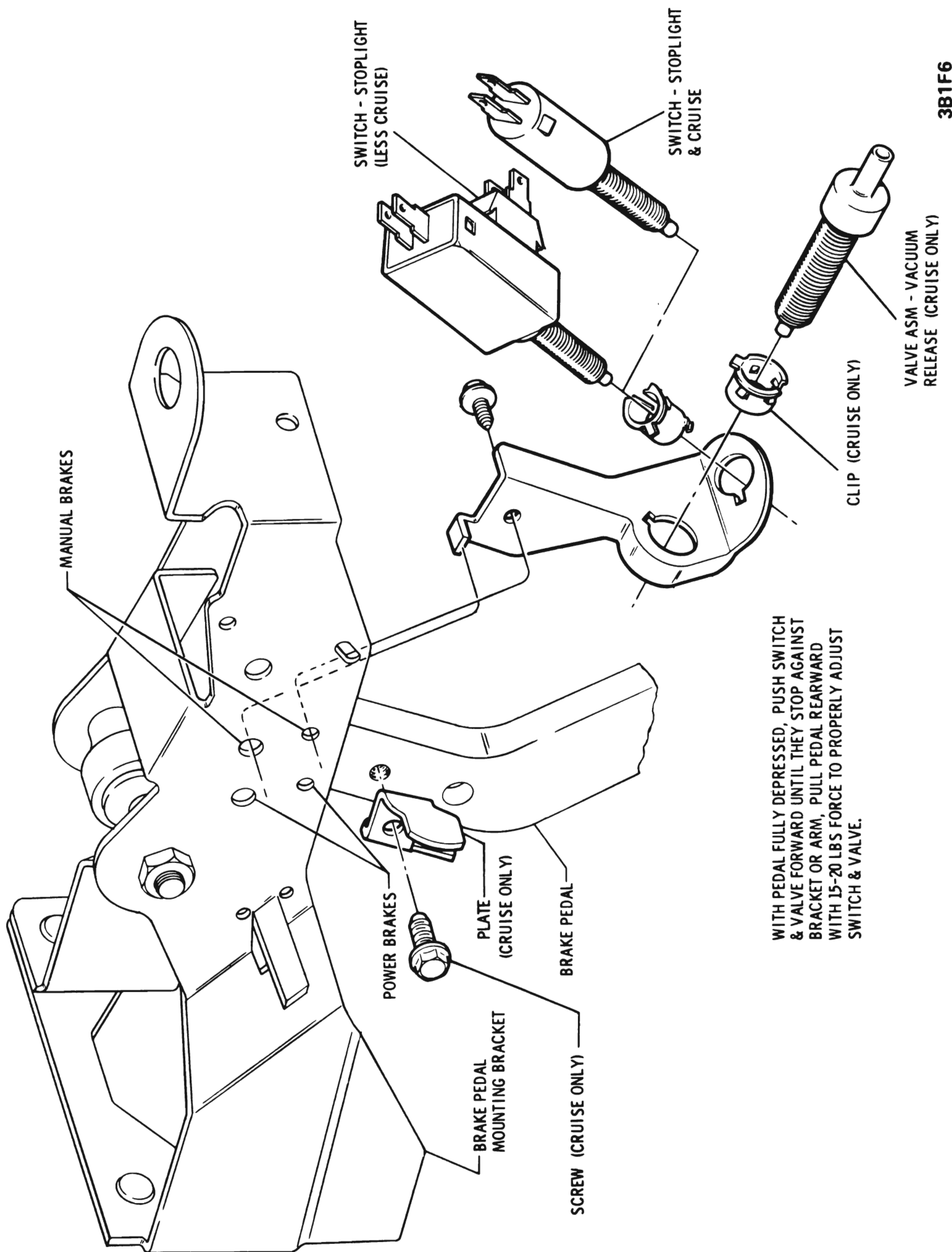
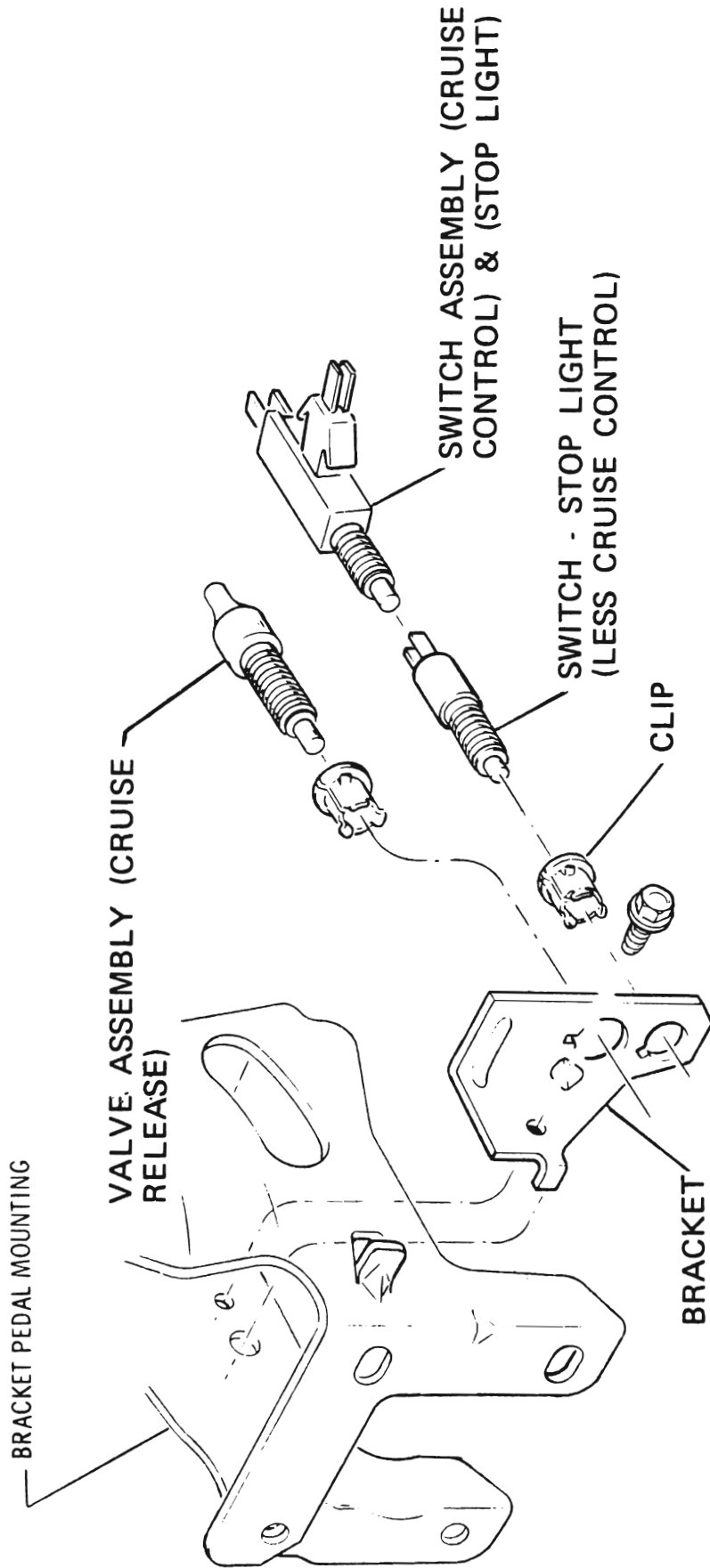

Figure 1F-6 Stoplight and Cruise Control Switch Adjustments - A Series



WITH BRAKE PEDAL FULLY DEPRESSED, PUSH SWITCH & VALVE FORWARD UNTIL THEY STOP AGAINST BRACKET OR ARM. PULL PEDAL REARWARD UNTIL 15-20 LBS FORCE TO PROPERLY ADJUST SWITCH & VALVE.

**3B1F7**

Figure 1F-7 Stoplight and Cruise Control Switch Adjustments - B-C-E Series