

SECTION C

STEERING COLUMN ASSEMBLIES

ALL SERIES

CONTENTS

Division	Subject	Page No.
I	TROUBLE DIAGNOSIS: (Not Applicable)	
II	DESCRIPTION AND OPERATION: Description	90-55
III	ADJUSTMENTS AND MINOR SERVICE: Checking Steering Column for Damage	90-56
	Removal and Installation of Horn Actuator Bar and Steering Wheel	90-57
IV	REMOVAL AND INSTALLATION: Removal and Installation of Steering Column Assembly	90-58
V	OVERHAUL AND MAJOR SERVICE: Disassembly and Assembly of Standard (Non-Tilt) Steering Column Assembly	90-61
	Disassembly and Reassembly of Tilt Steering Column Assembly	90-69
VI	SPECIFICATIONS: Specifications	90-75

DIVISION II

DESCRIPTION AND OPERATION

90-21 DESCRIPTION

The Energy Absorbing Function Locking Steering Column assembly is used on all series cars. This column is designed to compress under impact. When an automobile is being driven, the forward movement of the automobile and the forward movement of the driver both constitute a form of energy or force. When an automobile is involved in a frontal collision, the primary force (forward movement of the car) is suddenly halted, while the secondary force (the driver) continues its forward direction. A severe collision generally involves these two forces - the primary and

the secondary forces. The secondary impact occurs when the driver is thrust forward onto the steering wheel and column.

The Energy Absorbing Column is designed to absorb these primary and secondary forces to the extent that the severity of the secondary impact is reduced. During a collision, the steering column compresses and thereby reduces its tendency to move rearward into the driver's compartment. A split second later when the driver is thrown forward (the secondary impact) his energy is also partially absorbed by the compression characteristics of the column.

The Energy Absorbing Function Locking Column assembly may be easily disassembled and reassembled. The serviceman should be aware that it is important that only the specified screws, bolts and nuts be used as

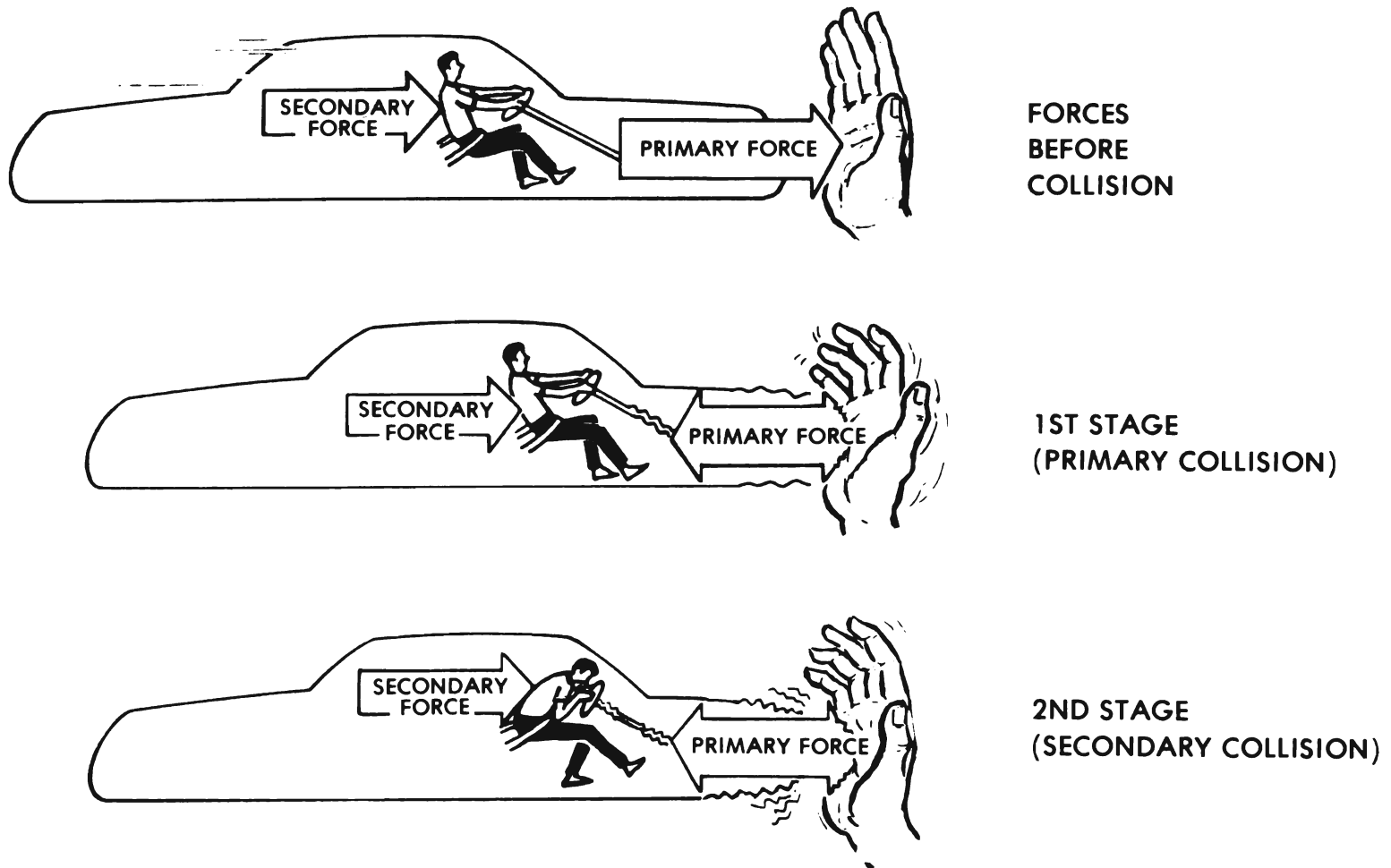

Figure 90-74 Reaction of Forces in a Collision

designated during reassembly, and that they are tightened to their specified torque. This precaution will insure the energy absorbing action of the assembly. Particular care should be exercised to avoid using overlength bolts as they may prevent a portion of the assembly from compressing under impact. Equally as important is correct torquing of all bolts and nuts. In particular, care should be taken to assure that the bolts or nuts securing the column mounting bracket to the instrument panel are torqued to the proper specification in order that the bracket will break away under impact.

When the Energy Absorbing Function Locking Column is installed in a car it is no more susceptible to damage through usage than an ordinary column; however, when the column is removed, special care must be taken in handling this assembly. *Only the specified wheel puller should be used.* When the column is removed from the car, such actions as a sharp blow on the end of the steering shaft or shift levers, laying things across or on top of the column assembly, leaning on the column assembly, or dropping of the assembly could shear or loosen the plastic fasteners that maintain column rigidity or possibly bend the assembly causing a binding condition. *It is therefore important that the removal and installation and the*

disassembly and reassembly procedures be strictly followed when servicing this assembly.

All Series Buicks incorporate a pot joint in the lower portion of the steering shaft. The pot joint acts as a universal joint to compensate for misalignment of the steering column. To insure proper operation of the pot joint, the capsule bracket and toe pan covers have been redesigned to provide exact alignment of the column in the body. It is mandatory that the installation of this column be followed exactly as outlined.

DIVISION III

ADJUSTMENTS AND MINOR SERVICE

90-22 CHECKING STEERING COLUMN FOR DAMAGE (ALL SERIES)

Cars involved in accidents resulting in frame damage, major body or sheet metal damage, or where the steering column has been impacted may also have a damaged or misaligned steering column.

1. Check capsules on steering column bracket assembly: They should be within 1/16" of bottom of the slots. If capsule has moved more than 1/16", some column collapse may have occurred, and the bracket must be replaced. In this case the steering column must be checked as outlined below.

2. On cars with automatic transmission and column shift, check operation of the shift lever. If you are able to move lever to "Park" position without raising lever, it is an indication that the upper shift tube plastic bearing is broken.

3. Check for mast jacket collapse by measuring the distance from the edge of the neutral-start switch window opening and the bottom of the upper jacket.

The correct dimension for the 4D-4F-4G-4H Series cars with Tilt Column is 5-9/64" to 5-11/64". For all other columns (standard or tilt) the dimension is 5 1/2" to 5 5/8". See Figure 90-75.

4. Check for broken plastic bearing adapter at lower end of steering shaft. (All except column shift manual transmission.) If adapter is cracked or broken, it must be replaced and the column aligned.

5. Check steering gear flexible coupling for stretching, compression, tears, excessive angularity or for no pin engagement. This indicates possible misalignment or frame damage. If flexible coupling damage is evident,

the coupling is to be replaced and the steering column is to be realigned.

6. Check for lower shaft end-play clearance in pot joint by grasping shaft and pushing into pot joint. Some end-play must be present. If no end-play is present, disconnect lower shaft assembly at flexible coupling and measure the distance, as shown in Figure 90-136.

If the above checks indicate the column has been damaged, the column must be disassembled for further inspection of internal components, such as shift tube, upper steering shaft injection molding, and turn signal switch.

After all repairs have been made or inspection completed, the column must be reinstalled according to the procedures outlined in Paragraph 90-24.

90-23 REMOVAL AND INSTALLATION OF HORN ACTUATOR AND STEERING WHEEL

A. Removal of Horn Actuator

1. Unplug flat connector from steering column.
2. On 4D-4F-4G-4H Series cars with standard steering wheel, pull off cap, remove three phillips head screws

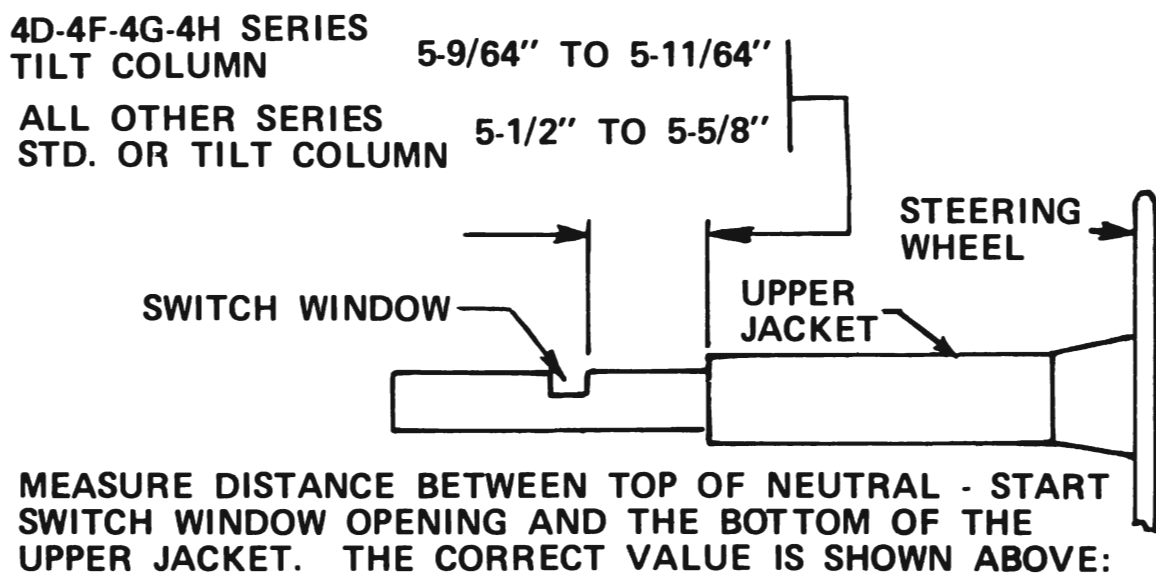

90-163A

Figure 90-75 Checking for Column Collapse

and take off bushing spacer, receiver cup and Belleville spring (see Figure 90-76).

3. On all other Series cars remove screws from underside of steering wheel that secure horn actuator, partially lift off bar, pull lead connector from canceling cam, then fully lift off actuator. See Figure 90-129.

B. Installation of Horn Actuator

Install reverse of removal.

C. Removal of Steering Wheel

1. Remove horn actuator cap or bar (ref. subparagraph a).

2. Loosen steering wheel retaining nut several turns. Do not remove nut.

3. Attach Wheel Puller J-3274 to steering wheel and pull wheel up to nut. See Figure 90-77. Do not tap or strike on end of puller in order to free wheel from shaft that maintain steering shaft rigidity. Striking of underside of steering wheel to jar it loose must also never be done. The only recommendation for freeing frozen steering wheels is to use a penetrating lubricant.

D. Installation of Steering Wheel

1. Install reverse of removal and align location mark

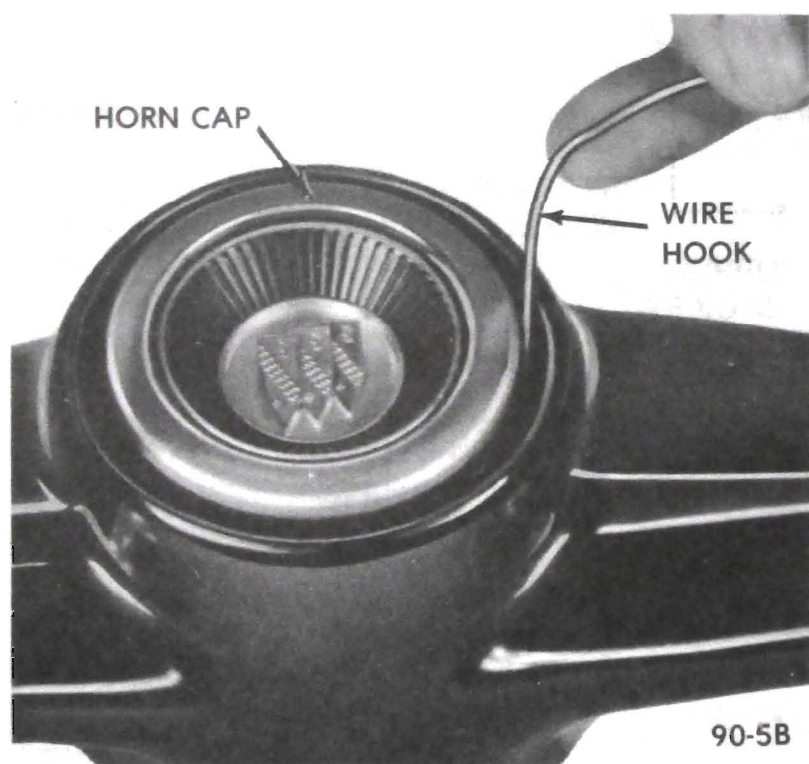

Figure 90-76 Horn Actuator Cap Removal
Standard Steering Wheel

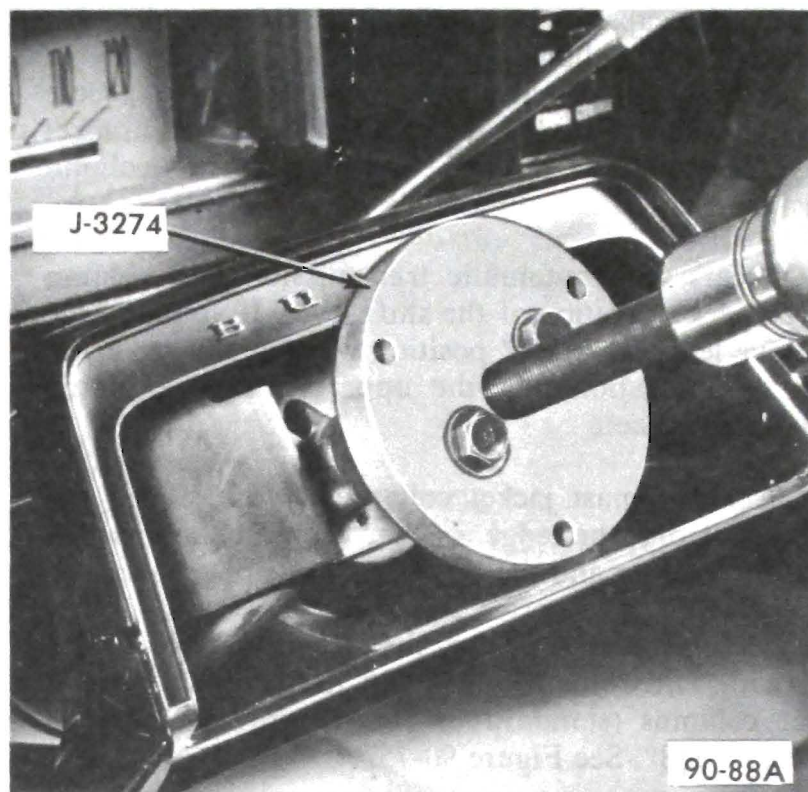

Figure 90-77 Removing Steering Wheel

on end of steering shaft with mark on hub of steering wheel.

2. Torque steering wheel nut 35 lb.ft.

CAUTION: *This steering wheel to steering shaft fastener is an important attaching part in that it could affect the performance of vital components and systems, and/or could result in major repair expense. It must be replaced with one of the same part number, or with an equivalent part, if replacement becomes necessary. Do not use a replacement part of lesser quality or substitute design. Torque values must be used as specified during reassembly to assure proper retention of this part.*

DIVISION IV

REMOVAL AND INSTALLATION

90-24 REMOVAL AND INSTALLATION OF STEERING COLUMN ASSEMBLY

A. Removal

(All Series)

Once the steering column is removed from the car, the column is extremely susceptible to damage. Dropping the column assembly on its end could collapse the steering shaft or loosen the plastic injections which maintain column rigidity. Leaning on the mast jacket could cause jacket to bend or deform. Any of the

above damage could impair the column's collapsible design. If it is necessary to remove the steering wheel, use the specified wheel puller. Do not hammer on end of shaft, as hammering could loosen plastic injections which maintain column rigidity.

1. Remove two nuts securing halves of flexible coupling together.
2. Disconnect shift linkage from shift lever(s).
3. Remove screws securing toe pan cover to floor and loosen cover.
4. Disconnect shift indicator link. See Figure 90- 78.
5. Remove nuts securing bracket to instrument panel and carefully lower column. See Figures 90-130 and 131.
6. Disconnect all electrical connectors from steering column assembly and carefully withdraw column. See Figures 90-79 and 80.

B. Installation

(4D-4F-4G-4H Series)

It is mandatory that the installation procedure be followed in exact sequence.

CAUTION: Fasteners in following steps are important attaching parts in that they could affect the performance of vital components and systems, and/or could result in major repair expense. It must be replaced with one of the same part number or with an equivalent part if replacement becomes necessary. Do not use a replacement part or lesser quality or substitute design. Torque values must be used as specified during reassembly to assure proper retention of this part.

1. Position column in the body and position the flange to the rag joint and install lock washers and nuts. With loose rag joint flange, install bolt (K) and torque to 30 lb. ft. See Figure 90-130.
2. Connect all electrical connectors to steering column. See Figure 90-79.
3. Position steering column to instrument panel, connect shift indicator link and loosely attach retaining nuts (F).
4. Position outer cover to dash and start screw (Q).
5. Install screw (L) and tighten to 40 lb.in. Tighten screw (Q) to 40 lb. in. Install and tighten screw (R) to 40 lb. in.
6. Tighten two clamp screws (C) to 40 lb. in.
7. Install and tighten two inner cover screws (J) to 40 lb. in.
8. Tighten two steering column retaining nuts to 20 lb. ft.
9. Install insulator and cover and tighten screws snug.
10. Connect shift linkage to shift lever.

Make certain that column instrument panel mounting is never unsupported when either dash mounting or gear mounting is connected.

(4L-4N-4R-4P-4U-4V-4Y Series)

It is mandatory that the installation procedure be followed in exact sequence.

CAUTION: Fasteners in the following steps are important attaching parts in that they could affect the performance of vital components and systems,

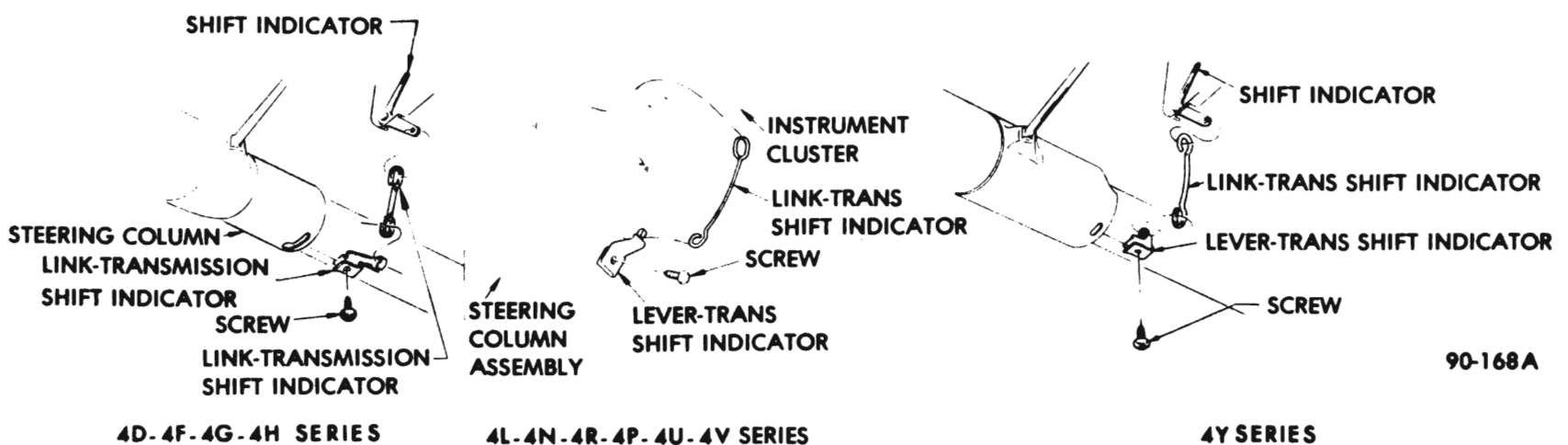
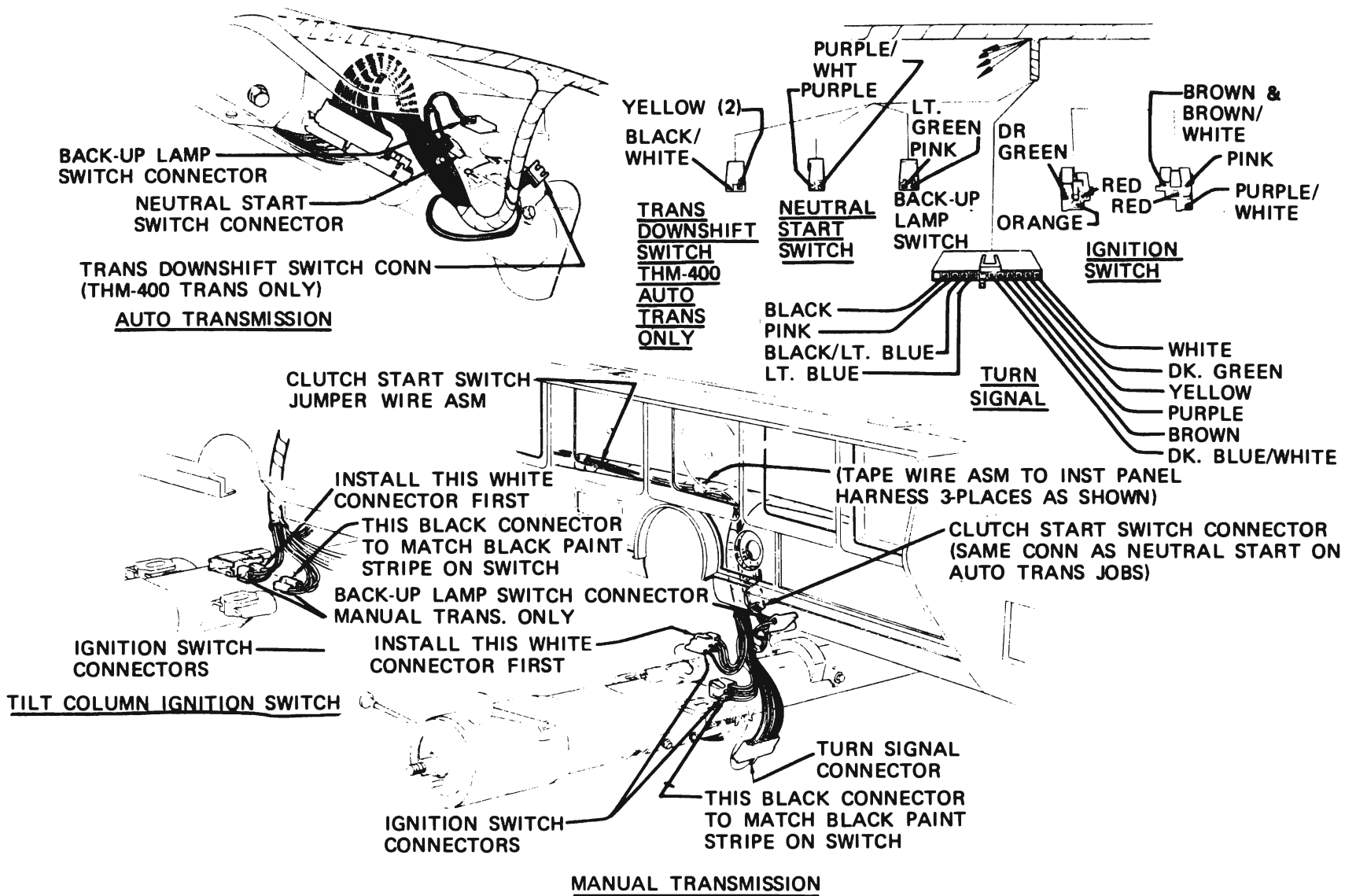

Figure 90-78 - Removing Shift Indicator Link



90-198C

Figure 90-79 - 4D-4F-4G-4H Steering Column Electrical Connections

and/or could result in major repair expense. It must be replaced with one of the same part number or with an equivalent part if replacement becomes necessary. Do not use a replacement part or lesser quality or substitute design. Torque values must be used as specified during reassembly to assure proper retention of this part.

1. Position column in the body and position the flange to the rag joint and install lock washers and nuts and torque to 20 lb. ft. See Figure 90-131.

2. Connect all electrical connectors to steering column. See Figure 90-80.

3. Position steering column to instrument panel loose assemble nuts and connect shift indicator link.

4. Position lower cover to dash by starting screw (7) in round inlet hole. See Figure 90-131.

5. Install screw (8) and torque to 40 lb. ft. Tighten screw (7) and torque to 40 lb. ft.

6. Install screw (3) and (9) and torque to 40 lb. ft.

7. Install clamp screw (4) and torque to 40 lb. ft.

8. Install remaining three cover screws and torque to 40 lb. ft.

9. Torque steering column to instrument panel nuts to 20 lb. ft.

10. Connect shift linkage to shift lever.

DIVISION V

OVERHAUL AND MAJOR SERVICE

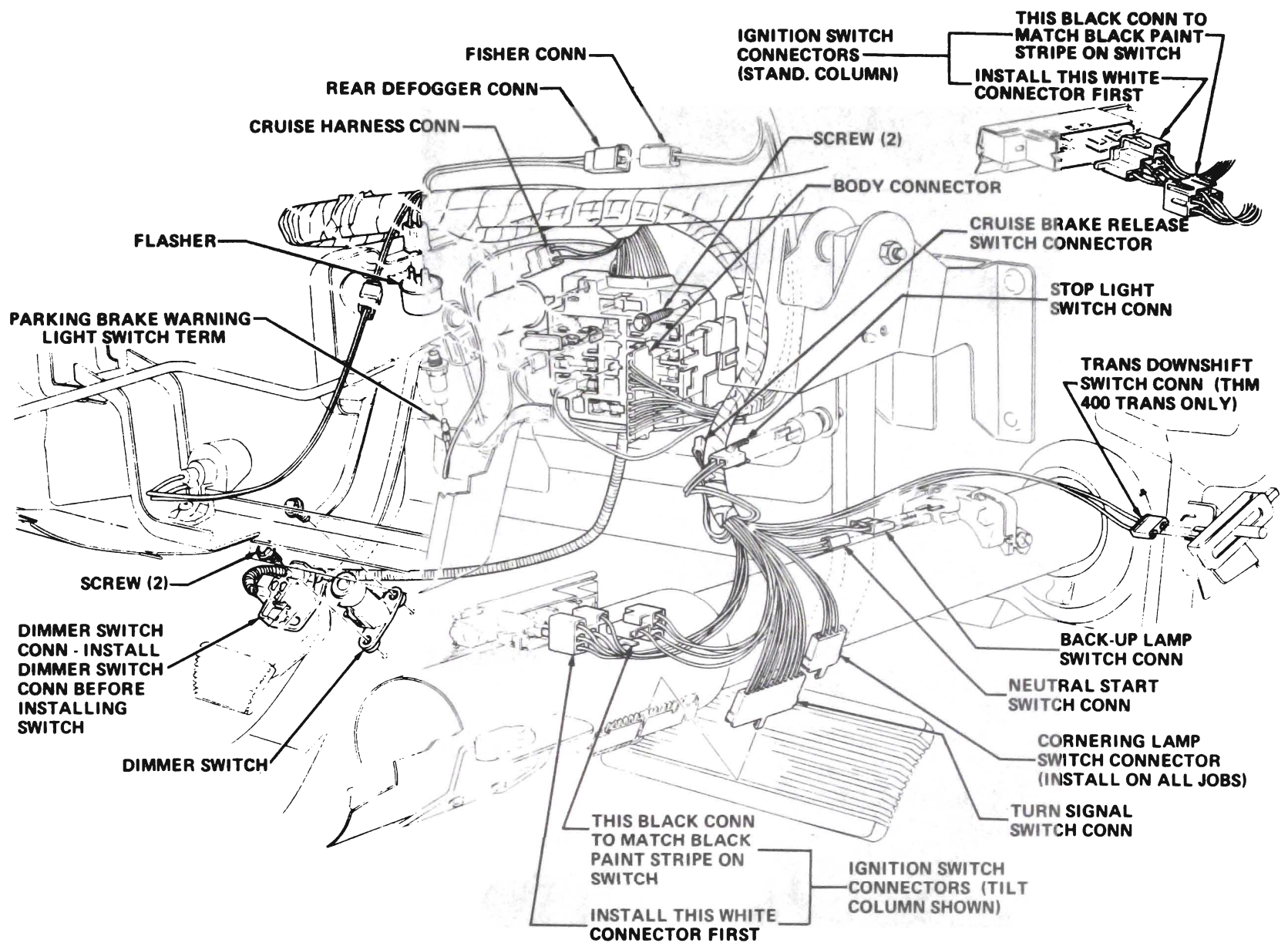

90-199C

Figure 90-80 - 4L-4N-4R-4P-4U-4V-4Y Steering Column Electrical Connections

90-25 DISASSEMBLY AND ASSEMBLY OF STANDARD (NON-TILT) STEERING COLUMN

All elements of energy absorbing columns are sensitive to damage and must be handled with care.

A. Disassembly - Upper End Only (Column Out Of Car)

If service is required on the upper end only, steps 1 through 12 can be performed in the car. **MAKE SURE COLUMN IS NOT BENT DURING REMOVAL FROM CAR.**

1. Remove steering wheel using specified wheel puller. Do not hammer end of steering shaft.
2. Remove the three cover screws and remove cover. Remove cardboard screw retainers.

3. Depress lock plate using tool J-23653 and the steering wheel nut. Pry the round wire snap ring out of the shaft groove and discard ring. Remove the snap ring and shaft lock plate. See Figure 90-84. With ring removed, shaft could slide out bottom of column causing damage to shaft.

4. Slide upper bearing preload spring and horn contact turn signal cancelling cam off upper steering shaft.
5. Slide thrust washer off upper steering shaft.
6. Remove turn signal lever screw and lever.
7. Push hazard warning switch in and unscrew knob.

8. Remove three turn signal switch mounting screws. Pull the connector out of the bracket on the jacket. Wrap a piece of tape around the upper part of the connector and wires to prevent snagging when removing switch. See Figure 90-85.

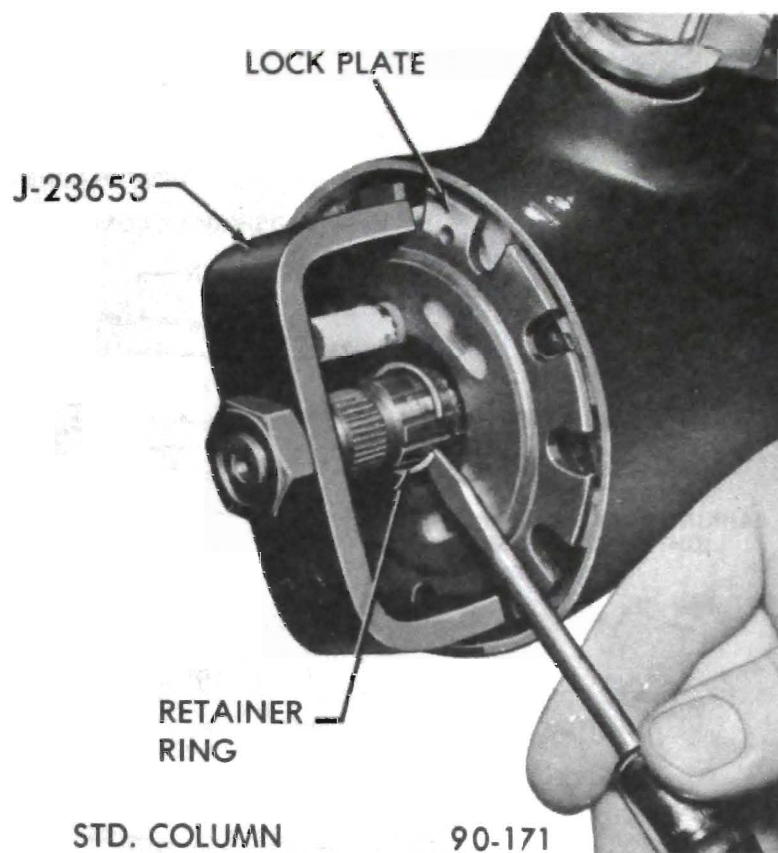
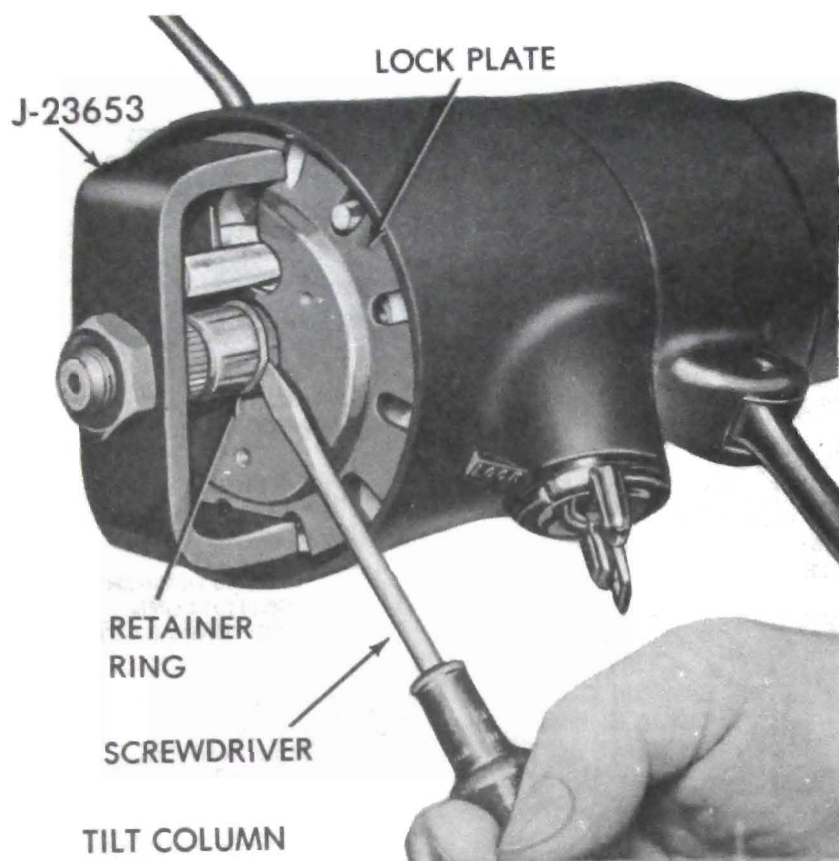

Figure 90-84 Removing Lock Plate Retainer Ring

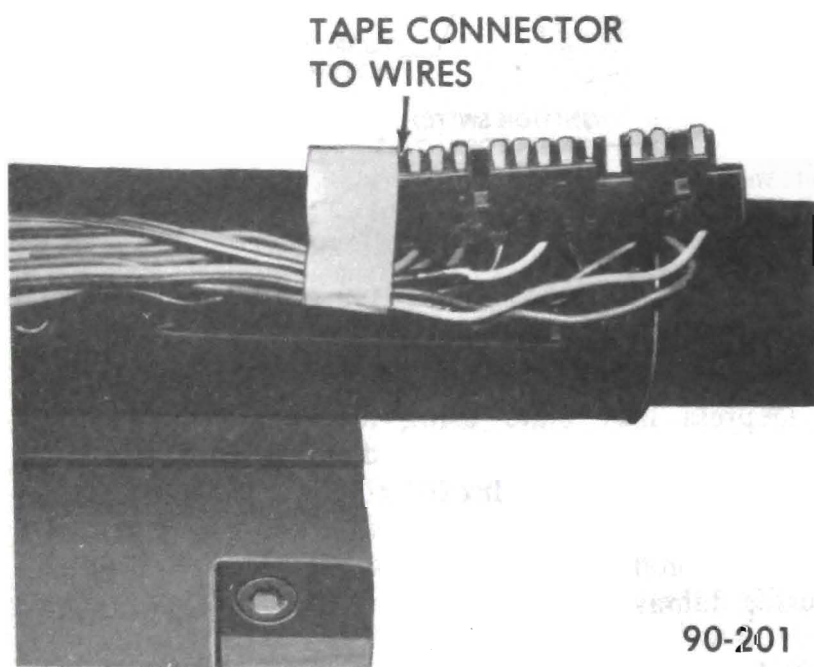

Figure 90-85 Tape Connector to Wires

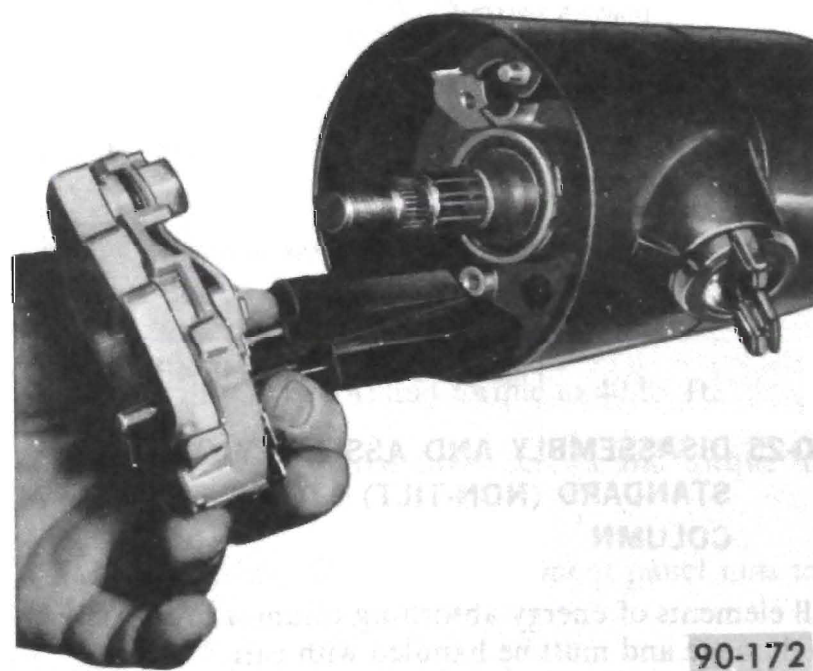

Figure 90-86 Removing Turn Signal Switch and Wires

9. Pull the switch straight up with wire protector. See Figure 90-86.

10. The lock cylinder may be removed in the "lock" position with the key removed, or in the "run" position.

11. Insert a thin tool (small screw driver or knife blade) into the slot next to the switch mounting screw

boss (right hand slot) and depress spring latch at bottom of slot, which releases lock. Remove lock. See Figure 90-87.

12. The buzzer switch can be pulled straight out of the housing. (This may be done without removing the lock cylinder. However, the lock cylinder must be in the "run" position.) See Figure 90-88. Do not pull on

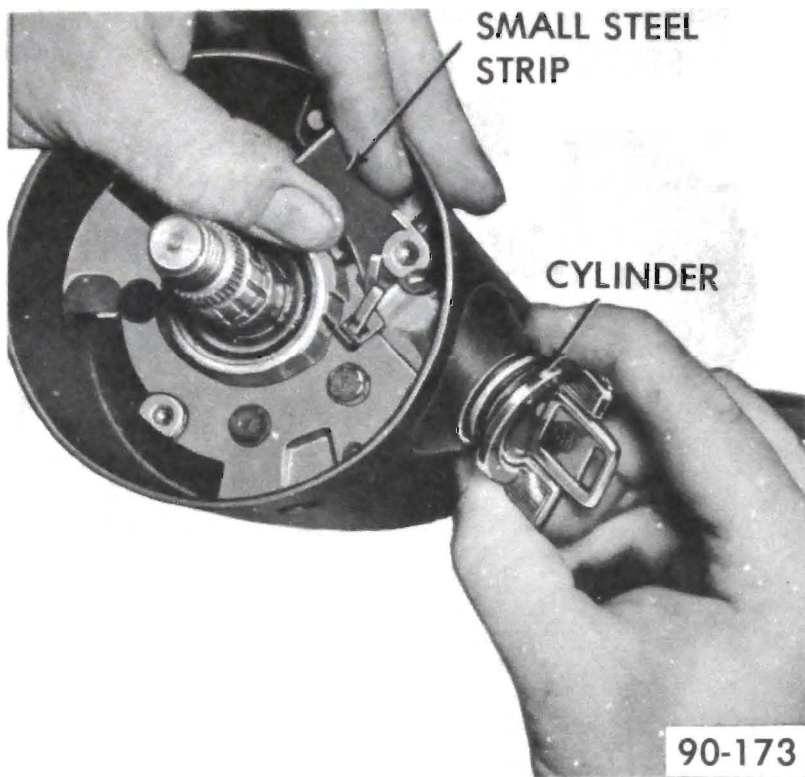

Figure 90-87 Removing Ignition Lock Cylinder

switch terminals. Use a bent wire or needle nose pliers to pull on switch clip.

To remove any additional parts from the upper end, the ignition switch should be removed.

13. The ignition switch should be positioned in "accessory" position before removing. If the lock cylinder has already been removed, the connecting rod to the switch should be pulled up until there is a definite stop, which is the "accessory" position. Now remove the two attaching screws and the switch.

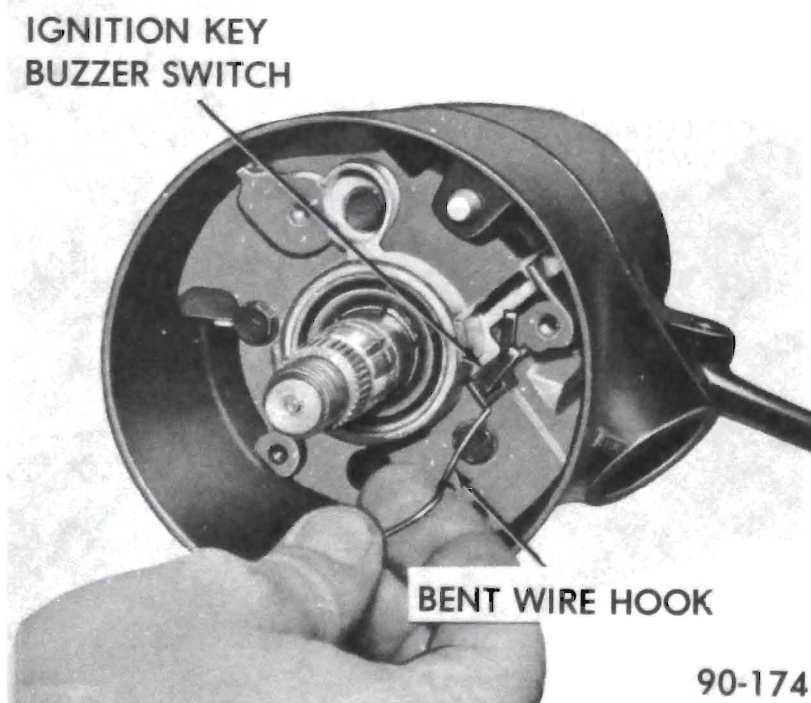

Figure 90-88 Removing Buzzer Switch

14. Drive out upper shift lever pivot pin and remove upper shift lever.

15. Remove the four screws attaching the upper housing to the jacket. Remove the upper housing assembly.

16. Remove thrust cup. See Figure 90-89.

17. Remove the rack and lock bolt. See Figure 90-90.

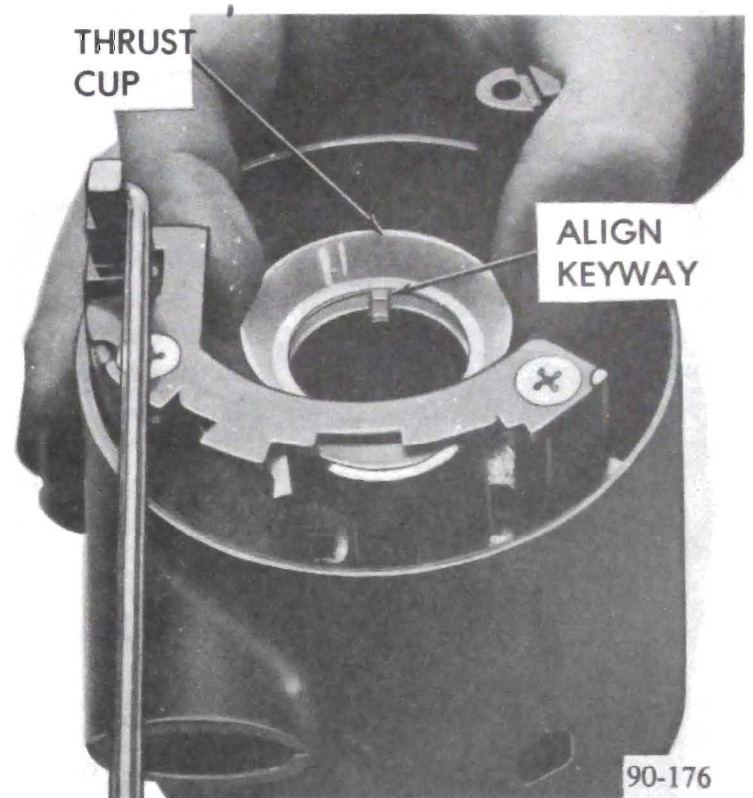

Figure 90-89 Removing or Installing Thrust Cup

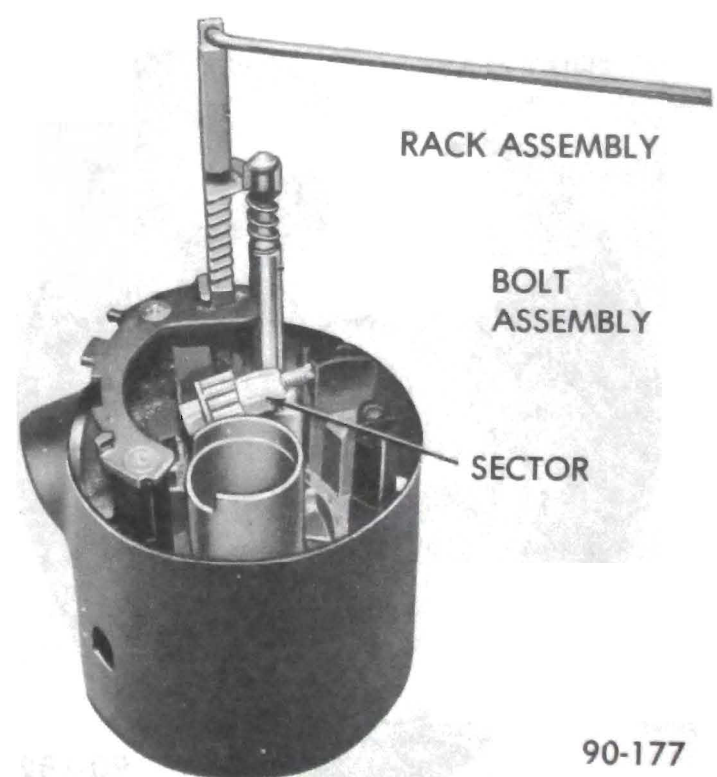

Figure 90-90 Removing or installing Rack and Lock Bolt.

18. Remove the load spring. See Figure 90-91.
19. Remove the shift gate. See Figure 90-92.
20. Remove the sector through the lock cylinder hole by pushing firmly on the block tooth of the sector with a blunt punch. See Figure 90-93.
21. Remove shift bowl and shroud from the jacket.

B. Disassembly of Lower End (Column out of Car)

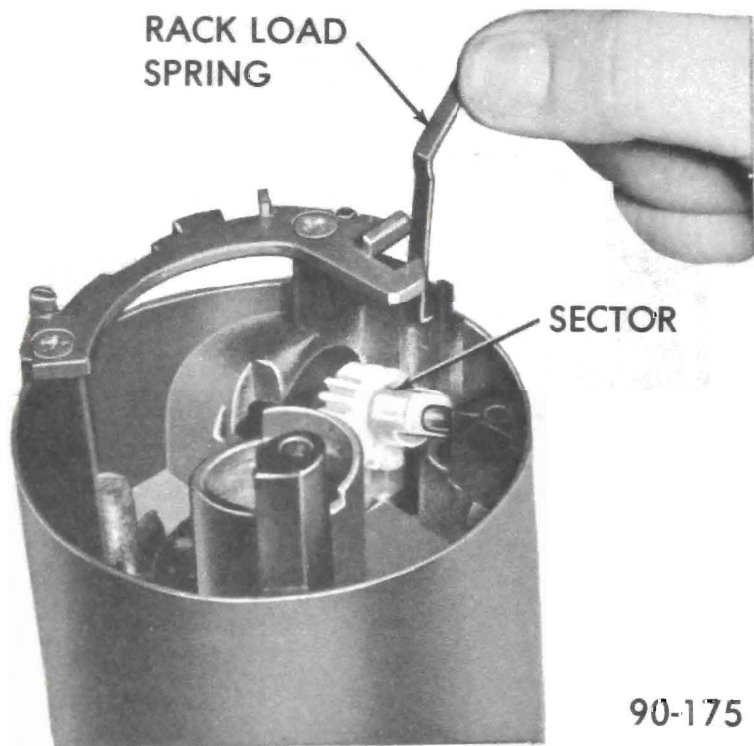

Figure 90-91 Removing or Installing Load Spring

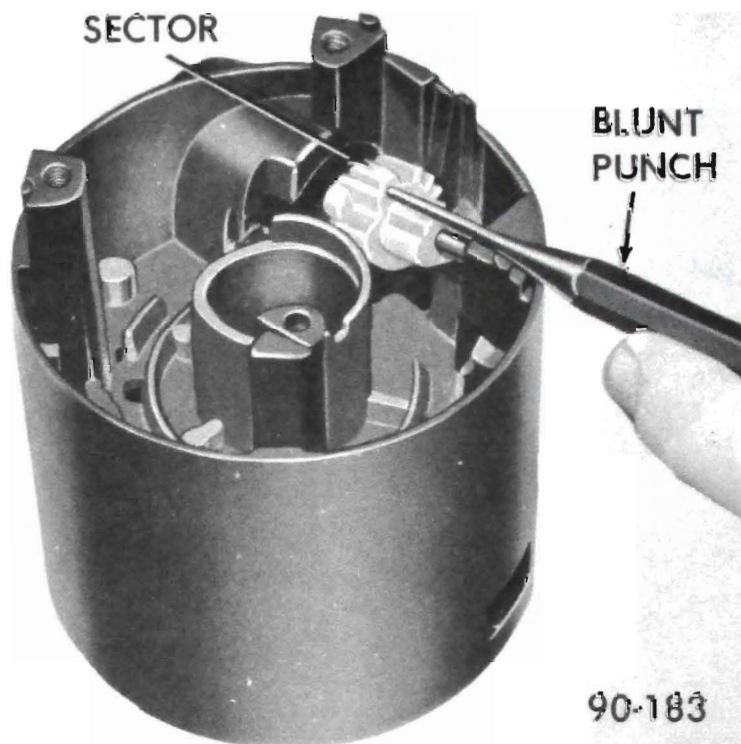

Figure 90-93 Removing Sector

Steering wheel, cover, shaft lock, "C" ring, spring, cancelling cam and flat washer must be removed prior to disassembly of the lower end. Follow instructions above.

1. Pull steering shaft assembly from bottom of column.
2. (Automatic Transmission) Remove the two screws holding the neutral-start switch and remove switch. See Figure 90-94.

(Manual Transmission) Remove the two screws



Figure 90-92 Removing Shift Gate

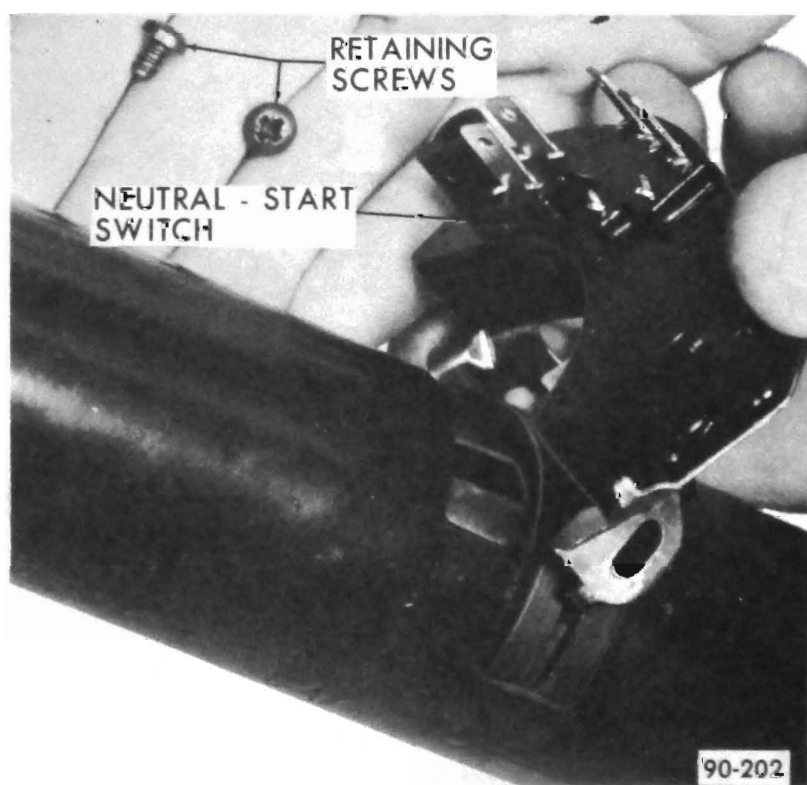

Figure 90-94 Removing or Installing Switch

holding the back-up switch and remove switch. See Figure 90-94.

3. Remove bearing adapter clip. See Figure 90-95.

4. (Automatic Transmission) Remove bearing adapter retainer, bearing and adapter assembly and shift tube spring. (Bearing may be removed from adapter by a light pressout operation on the outer race of the bearing. See Figure 90-96.

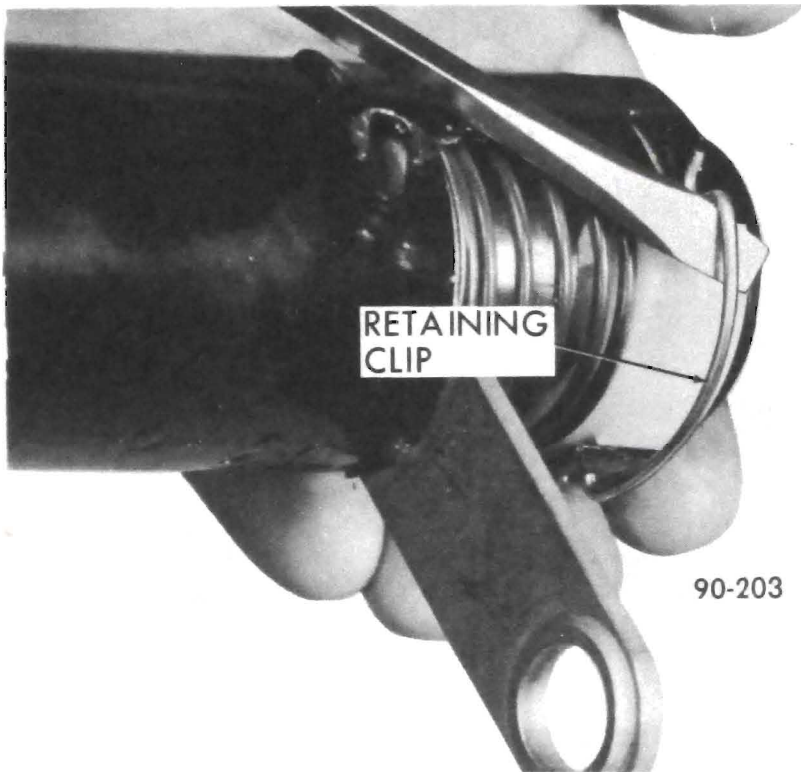

Figure 90-95 Removing Bearing Adapter Clip

(Manual Transmission) Remove bearing and adapter assembly and first/reverse lever. (Bearing may be removed from adapter by a light pressout operation on the outer race.)

5. (Manual Transmission Only) Remove three screws from bearing at lower end. See Figure 90-97.

6. Slide out shift tube assembly.

7. (Automatic Transmission Only) Remove wave washer and lower bowl bearing from top of jacket. See Figure 90-98.

C. Reassembly of Upper End

CAUTION: *Fasteners in the following steps are important attaching parts in that they could affect the performance of vital components and systems, and/or could result in major repair expense. It must be replaced with one of the same part number or with an equivalent part if replacement becomes necessary. Do not use a replacement part or lesser quality or substitute design. Torque values must be used as specified during reassembly to assure proper retention of this part.*

Apply a thin coat of E.P. No. 1 Grease to all friction surfaces.

Only the specified screws should be used during assembly operations.

1. Install the sector in the lock cylinder hole over the sector shaft with the tang end to the outside of

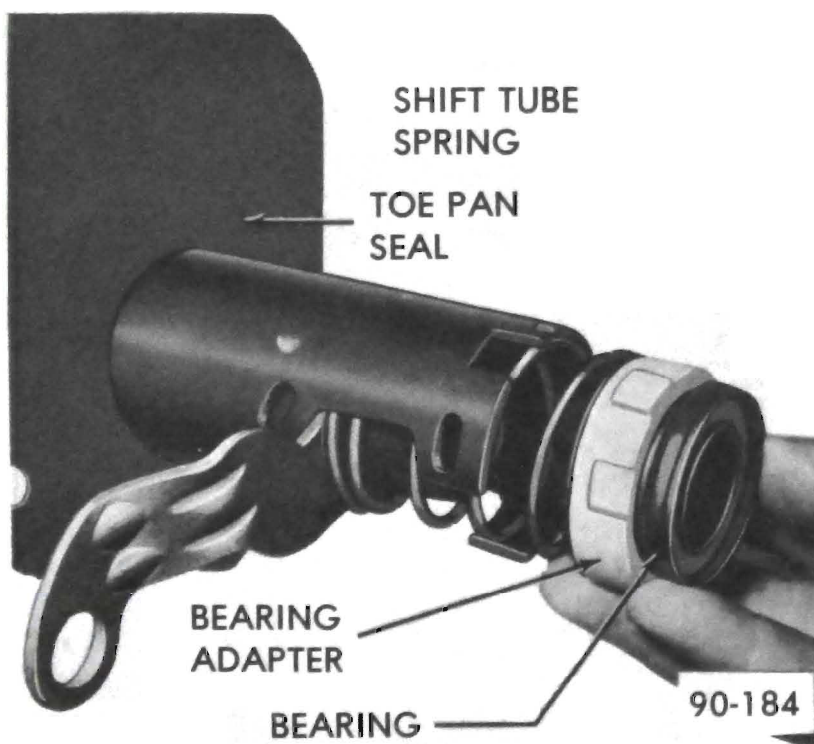

Figure 90-96 Removing Lower Steering Column Bearing

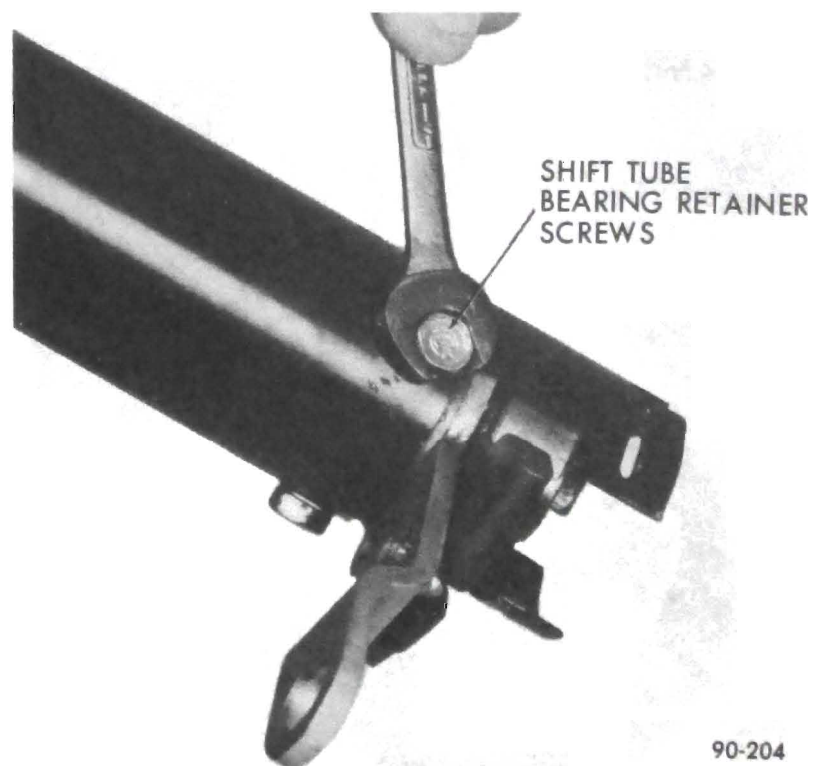
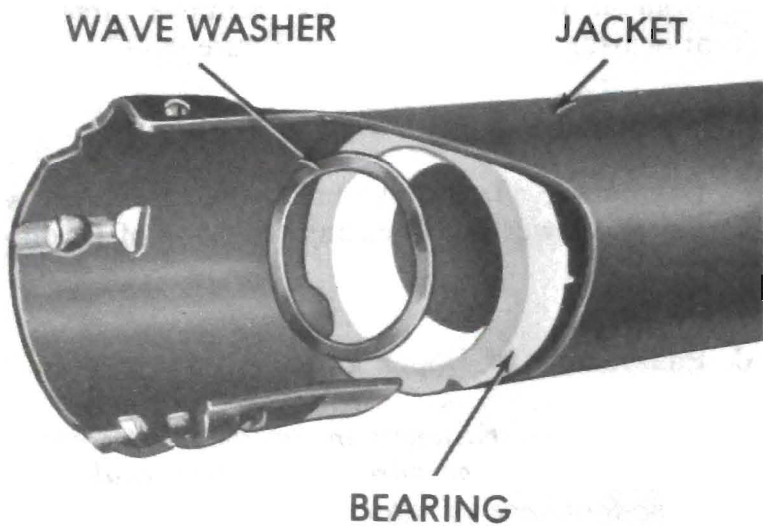

Figure 90-97 Removing Screws from Shift Tube Bearing-Manual Transmission



90-179

Figure 90-98 Removing Lower Bowl Bearing

the hole. Press the sector over the pin with a blunt tool. See Figure 90-99.

2. Install the shift gate to the housing.

3. Insert the rack spring in the housing from the bottom side. The long section should be toward the steering wheel and hook on the edge of the housing. See Figure 90-91.

4. Assemble the bolt to the cross-over arm of the rack. See Figure 90-100.

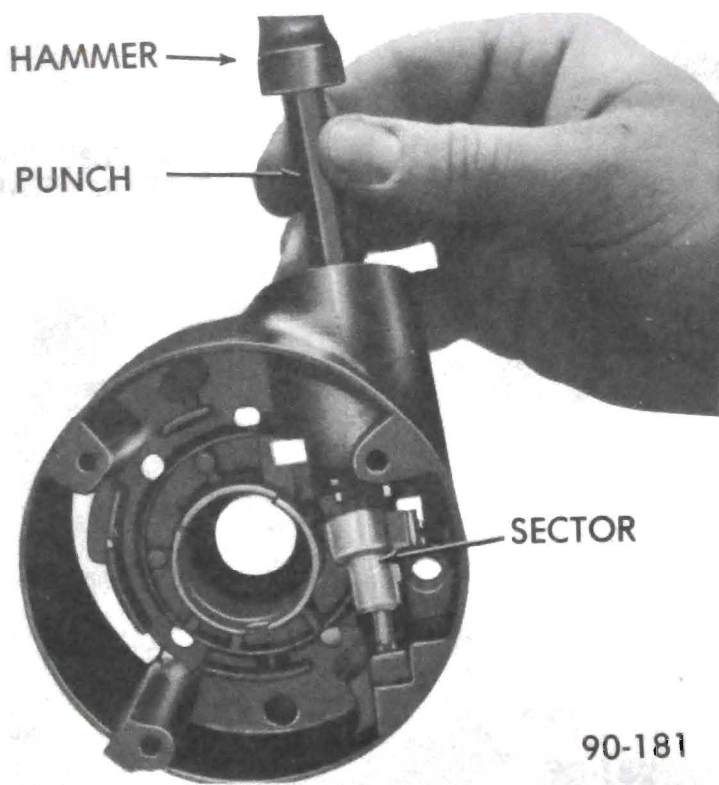

90-181

Figure 90-99 - Installing Sector

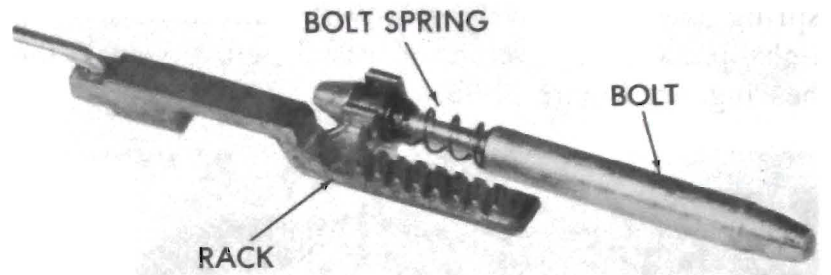

90-205

Figure 90-100 - Assembling Bolt to Rack Cross-Over Arm

5. Insert the rack and lock bolt into the housing from the bottom with the teeth up (toward steering wheel) and toward the centerline of the column. See Figure 90-101.

6. Install the thrust cup on the bottom hub of the housing. Be sure key of cup aligns with keyway in hub. See Figure 90-89.

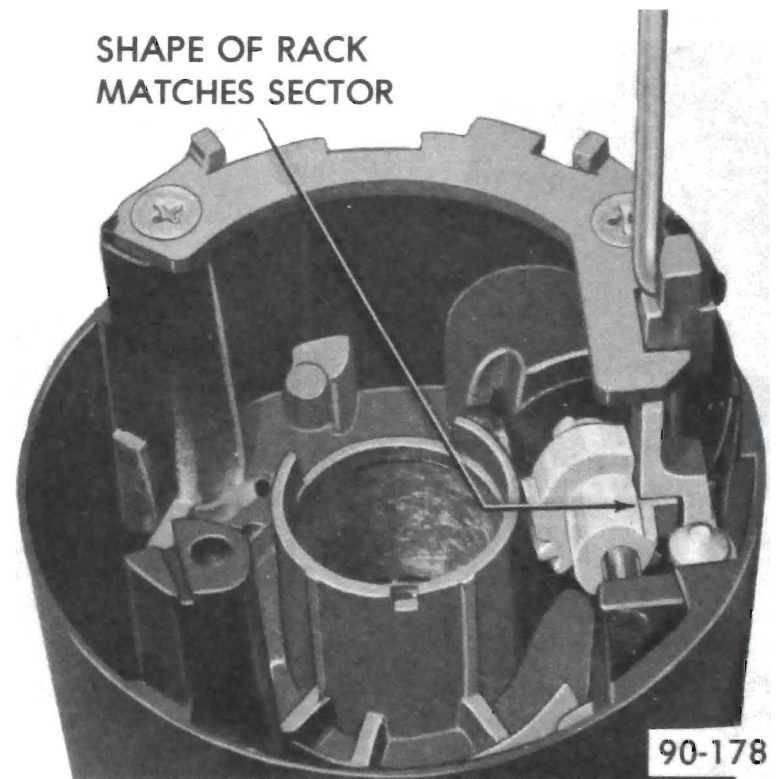

90-178

Figure 90-101 - Rack and Lock Bolt Assembled to Sector

7. Install lower bowl bearing in jacket and place wave washer in bowl bearing. See Figure 90-98.

8. Install bowl and rotate it to be sure it is seated in bearing. See Figure 90-102. Shift lever must not be installed before installing bowl.

9. With the bowl in place, install the upper bearing housing assembly on the jacket. The bowl should be in the "Park" position and the rack pulled downward. Be sure the housing is seated on the jacket and install the screws. See Figure 90-103.

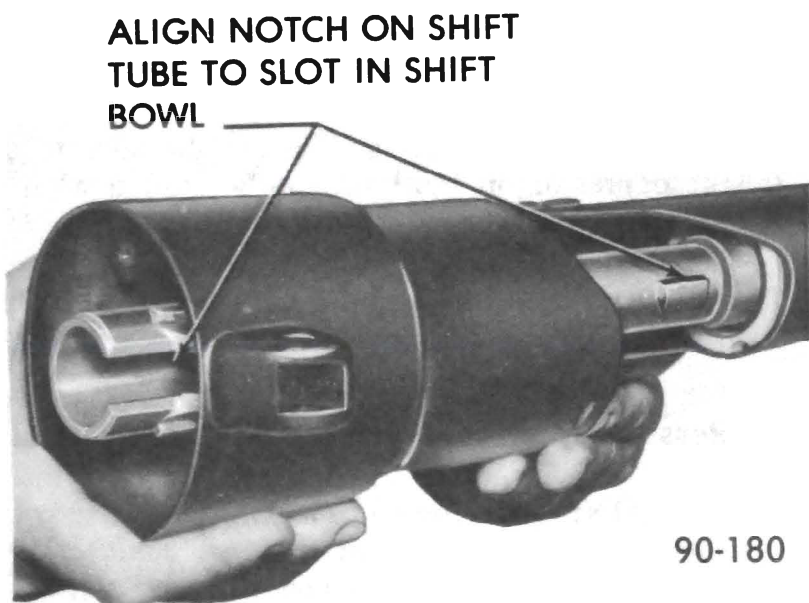

Figure 90-102 - Installing Shift Bowl

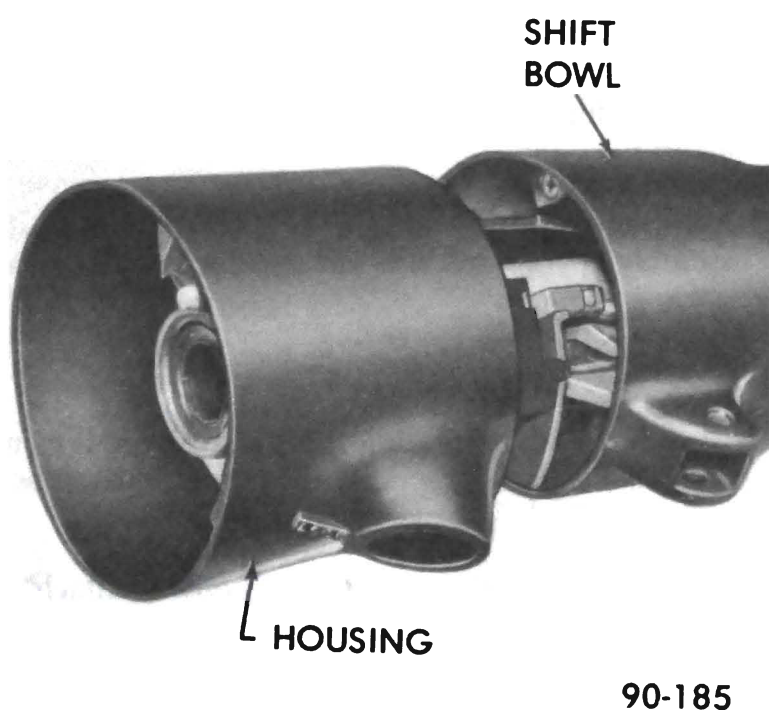

Figure 90-103 Installing Upper Bearing Housing

10. Assemble buzzer switch to spring clip with formed end of clip around the lower end of switch and spring bowed away from switch. This should lay on the switch opposite the contacts. Push switch and spring into hole with contacts toward the cylinder bore. See Figure 90-104.

11. To replace the turn signal switch, be sure the wire harness is in the protector. Feed the connector and protector down through the housing. See Figure 90-82.

12. Drive the three mounting screws. Clip the connector to the bracket on the jacket. See Figure 90-105.

13. To install lock, hold lock cylinder sleeve and rotate knob clockwise against stop. Insert cylinder into housing bore with key on cylinder sleeve aligned to keyway in housing, push in to abutment of cylinder and sector. Rotate knob counterclockwise, maintaining a light push inward on cylinder, until drive section of cylinder mates with sector. Push in until snap ring pops into grooves and lock cylinder is secured in housing. Check freedom of rotation.

14. When installing the ignition switch, be sure the lock cylinder is in "Lock" position. Make certain that the switch is in "Lock". Fit actuator rod into switch and assemble to column with two screws. See Figure 90-106.

15. Install the washer, spring and horn contact - cancelling cam on shaft, making certain that the turn signal switch is in "Neutral" and the hazard warning

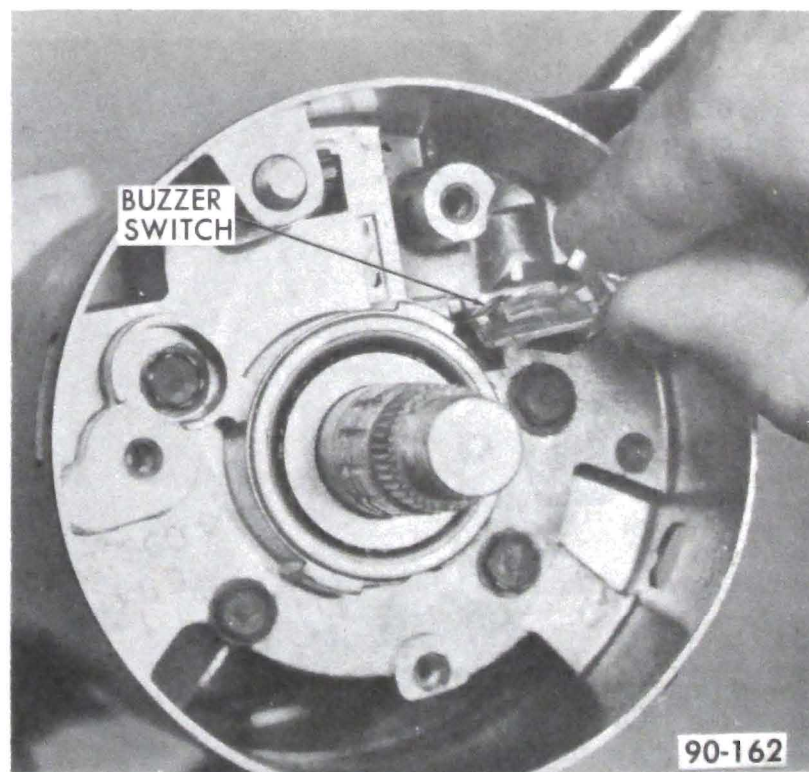
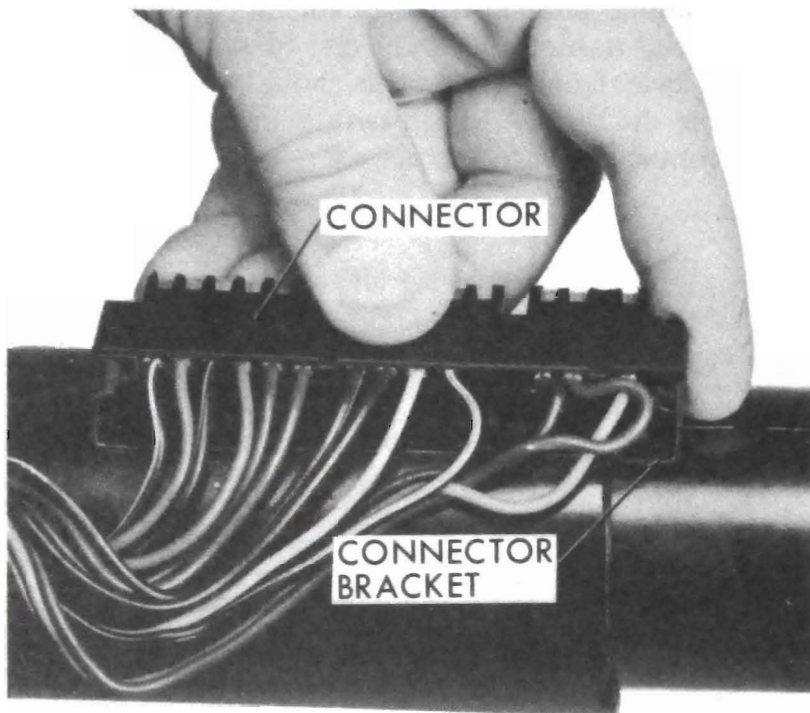

Figure 90-104 Installing Buzzer Switch Clip and Switch



90-206

Figure 90-105 - Installing Connector in Column Bracket

plunger is out. Install the shaft lock plate on the shaft. See Figure 90-107.

The turn signal switch assembly may be damaged if the above procedure is not followed.

16. Depress shaft lock plate using Tool J-23131 and install a new snap ring in groove on shaft.

17. Place cover on shaft lock and install screws.



Figure 90-107 - Horn Contact - Cancelling Cam Installed

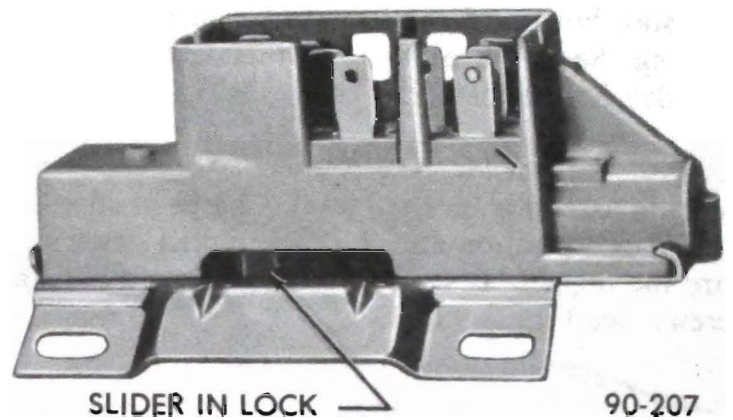

Figure 90-106 - Ignition Switch Slider in "Lock" Position

18. Install steering wheel and levers. Be sure to use tongue depressor on bowl spring. Be sure bowl is in "Drive" when inserting shift lever.

19. Adjust neutral-start back-up light switch with shift lever in "Drive" position.

D. Reassembly of Lower End

CAUTION: *Fasteners in the following steps are important attaching parts in that they could affect the performance of vital components and systems, and/or could result in major repair expense. It must be replaced with one of the same part number or with an equivalent part if replacement becomes necessary. Do not use a replacement part or lesser quality or substitute design. Torque values must be used as specified during reassembly to assure proper retention of this part.*

Apply a thin coat of E.P. No. 1 Grease to all friction surfaces.

Only the specified screws should be used during assembly operations.

1. Press the lower bearing assembly into adapter assembly.

2. Insert the shift tube assembly into the lower end of the jacket and rotate until the upper shift tube key slides into the bowl keyway. See Figure 90-102.

3. (Manual Transmission Only) Loosely attach three screws in jacket and shift tube bearing. See Figure 90-97.

4. (Automatic Transmission) Assemble the spring and adapter assembly into the bottom of the jacket. Holding the adapter in place, insert the snap ring in the jacket slots.

(Manual Transmission) Assemble the first/reverse lever and adapter assembly into the bottom of the jacket. Holding the adapter in place, insert the snap ring in the jacket slots. See Figure 90-108.

5. (Manual Transmission Only) Place a .005 shim between first/reverse lever and lever spacer and turn upper shift bearing down and tighten the three screws. Remove shim. See Figure 90-109.

6. (Automatic Transmission) Install the neutral-start

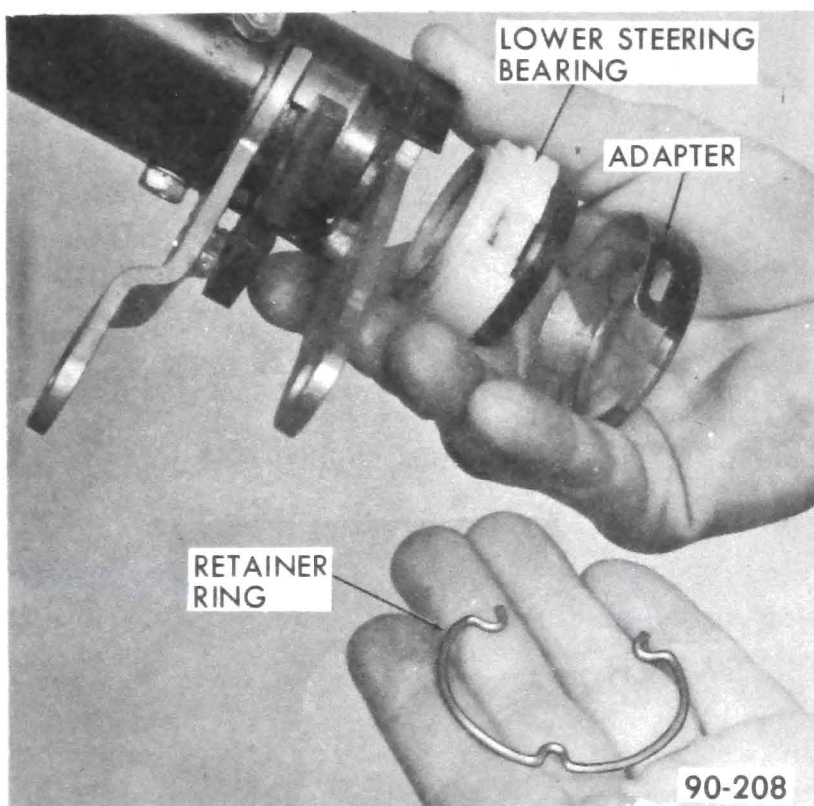

Figure 90-108 - Installing Lower Steering Column Bearing - Manual Transmission

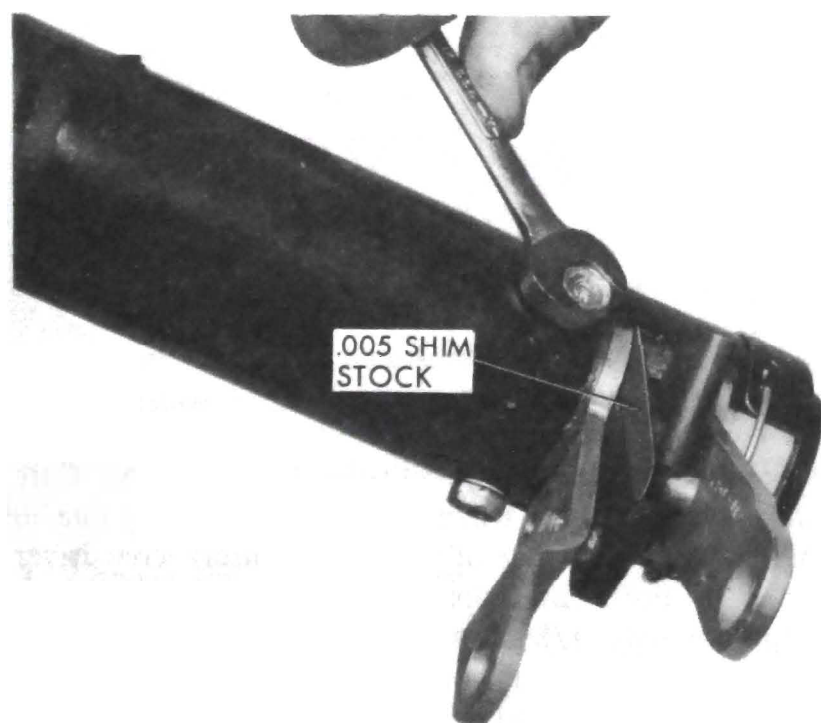

Figure 90-109 - Adjusting Shift Tube Bearing

switch, making certain the proper screws are used. See Figure 90-94.

(Manual Transmission) Install back-up switch, make certain only the proper screws are used. See Figure 90-94.

7. Slide steering shaft assembly into column.

The upper housing should be in place before the shaft is assembled.

8. Depress shaft lock plate using Tool J-23653 and install a new snap ring in groove on shaft.

The turn signal switch assembly may be damaged if the above procedure is not followed.

9. Place cover on shaft lock and install screws.

10. Install steering wheel and levers. Be sure to use tongue depressor on bowl spring. Be sure bowl is in "Drive" when inserting shift lever.

11. Adjust neutral-start back-up light switch with shift lever in "Drive" position.

90-26 DISASSEMBLY AND ASSEMBLY OF TILT STEERING COLUMN

All elements of energy absorbing columns are sensitive to damage and **MUST BE HANDLED WITH CARE.**

A. Disassembly (Column Out of Car)

If service is required on the upper end only, steps 1 thru 24 may be performed in the car. It will be necessary however, to lower steering column from instrument panel so that bracket can be removed to allow removal of turn signal switch and wires.

1. Remove column mounting bracket from column and **SET ASIDE TO PROTECT BREAKAWAY CAPSULES.**

2. Mount assembly in vise by clamping weld nuts on column in vise.

3. Remove steering wheel using specified wheel puller. Do not hammer on end of steering shaft.

4. Remove signal switch wire protector. See Figure 90-110.

5. Remove three cover screws and remove cover.

6. Remove tilt release lever, turn signal switch lever, push hazard warning plunger in and remove hazard warning knob. Remove upper shift lever from bowl.

7. Depress lock plate using tool J-23131 and the

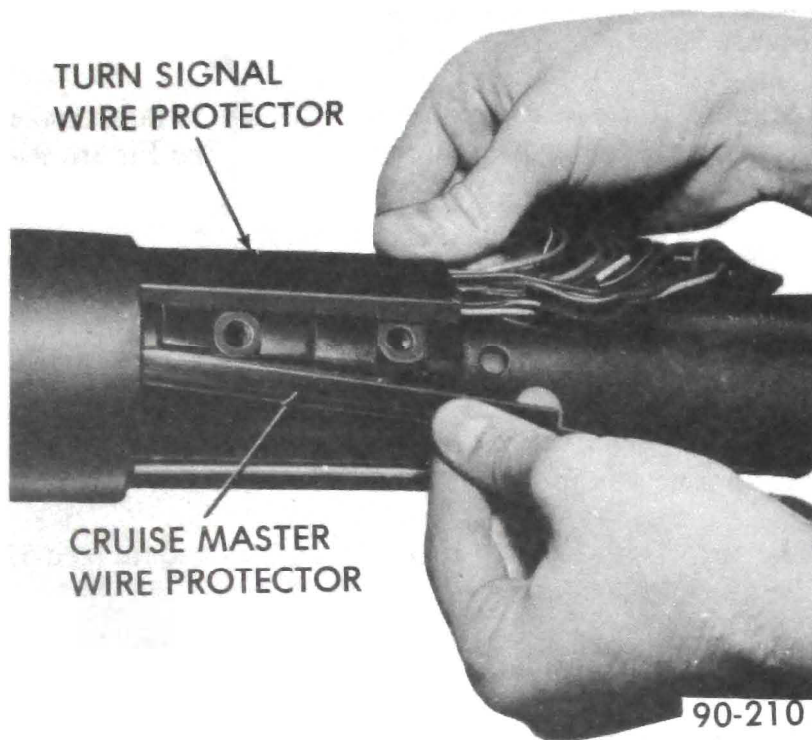

Figure 90-110 - Signal Switch Wire Protector

steering wheel nut. Pry the round wire snap ring out of the shaft groove and discard ring. Remove the shaft lock plate. See Figure 90-84.

8. Remove cancelling cam and cancelling cam spring.
9. Remove three turn signal switch mounting screws. Wrap a piece of tape around the upper part of the connector and wires to prevent snagging when removing switch. See Figure 90-85.
10. Position shift bowl or shroud (if floor shift column) in "Low" position. Pull the switch straight up.
11. The lock cylinder may be removed in any position from "Accessory" to "Run". However, the accessory position is recommended because of its positive location.

12. Insert a thin tool (small screwdriver or knife blade) into the slot next to the switch mounting screw boss (right-hand slot) and depress spring latch at bottom of slot, which releases lock. Remove lock. See Figure 90-111.

13. The buzzer switch can be pulled straight out of the housing. (This may be done without removing the lock cylinder. However, the lock cylinder must be in the "Run" position.) See Figure 90-112. Do not pull on switch terminals. Use a bent wire or needle nose pliers to pull on switch clip.

14. Remove three housing cover screws and remove housing cover.

15. Install tilt release lever and place column in full "Up" position. Remove tilt spring retainer using

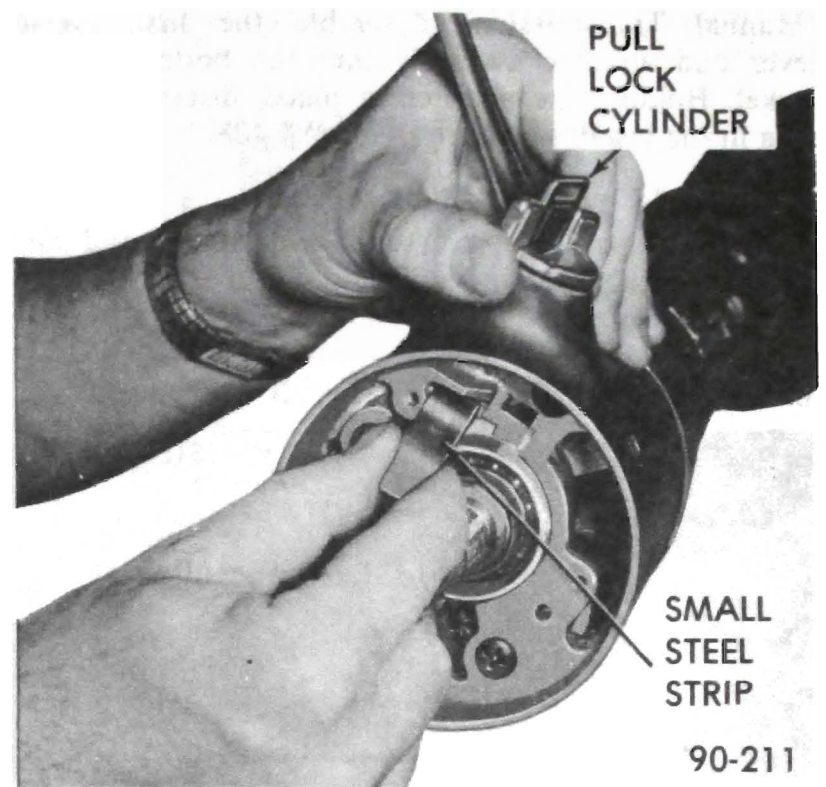

Figure 90-111 - Removing Ignition Lock Cylinder

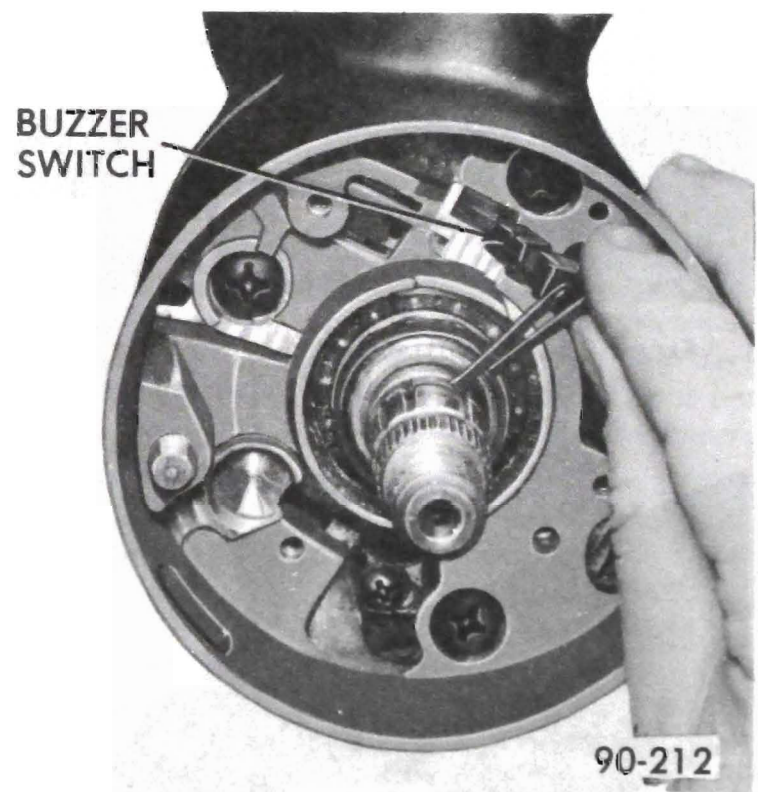
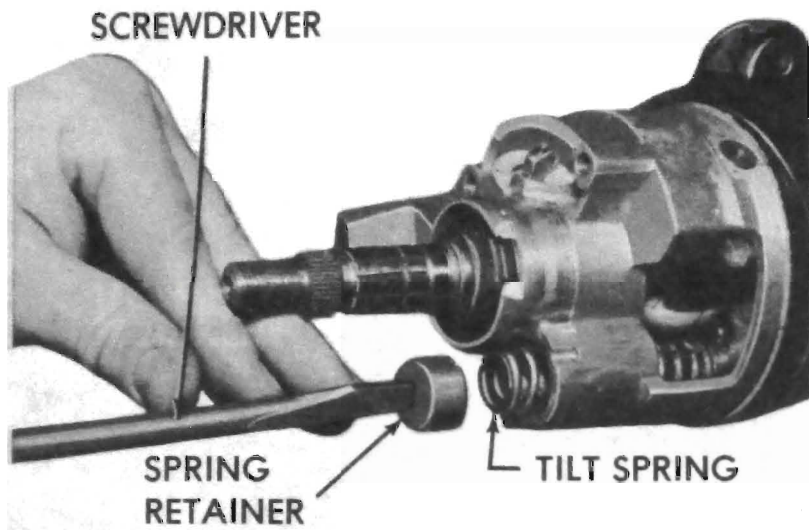

Figure 90-112 - Removing Buzzer Switch

screwdriver blade that just fits into slot opening. Care should be observed when releasing tilt spring due to high compression rate of the spring. Insert screwdriver in slot, press in approximately 3/16 inch, turn approximately 1/8 turn counterclockwise until ears align with grooves in housing and remove spring and guide. See Figure 90-113.

16. Place tilt column in neutral position, and push upper steering shaft in sufficiently to remove steering shaft inner race seat and inner race.



90-143A

Figure 90-113 - Removing Tilt Spring Retainer

17. (In car) Remove upper flange pinch bolt.

(Out of car) Remove lower steering shaft flange, no-back washer (if one is used), spacer, spring, clip and bearing adapter assembly at lower end of the mast jacket.

18. With ignition switch in "Accessory" position, remove two ignition switch mounting screws and ignition switch. Remove two neutral-start switch screws and neutral-start switch.

19. Remove two pivot pins with Tool No. J-21854-1. See Figure 90-116.

20. Install tilt release lever place in full "UP" and disengage lock shoes. Remove bearing housing assembly by pulling upward to extend rack full down and moving housing assembly to the left to disengage rack from actuator. Remove actuator rod assembly.

21. Remove steering shaft assembly from upper end.

22. Disassemble steering shaft assembly by removing centering spheres and anti-lash spring. See Figure 90-117.

23. Remove four support screws and remove support assembly.

24. Remove shift tube retaining ring with screwdriver. Remove thrust washer.

25. Remove shift tube from bowl using Remover J-23072. Pilot adapter in upper end of shift tube and force tube out of bowl. Care should be taken not to

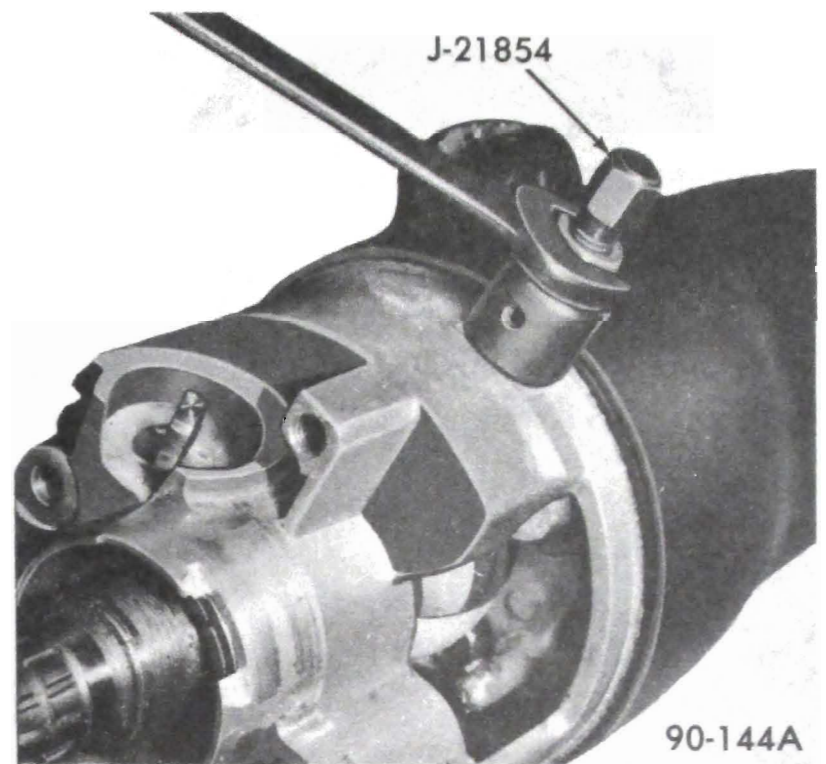
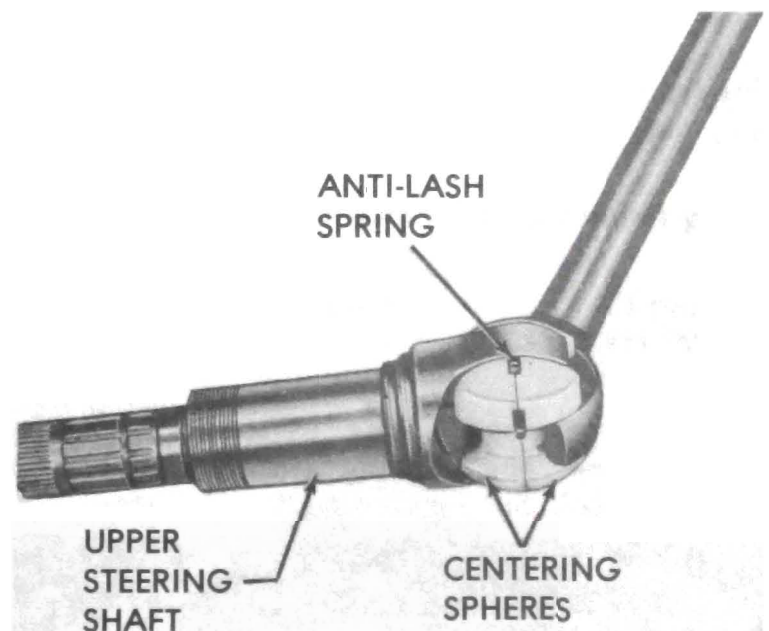

Figure 90-116 - Removing Pivot Pin



90-101A

Figure 90-117 - Steering Shaft and Centering Spheres

jam lower shift lever into "T" slot on lower end of mast jacket while forcing out shift tube. See Figure 90-118.

26. Remove shift tube assembly from mast jacket from lower end.

27. Remove lock plate and wave washer.

28. Remove bowl from mast jacket. Remove shift lever

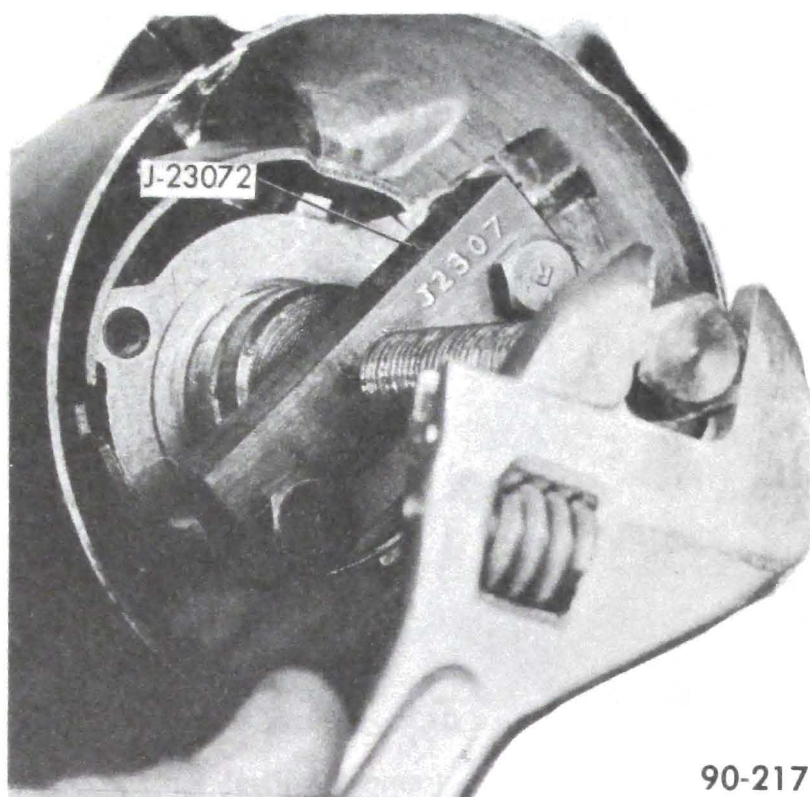

90-217

Figure 90-118 - Removing Shift Tube

spring from bowl by winding spring up with pliers and pulling out.

(Bearing Housing Disassembly)

1. Remove tilt lever opening shield from housing. See Figure 90-119.

2. Remove lock bolt spring by removing spring retaining screw and moving spring clockwise to remove from bolt. See Figure 90-120.

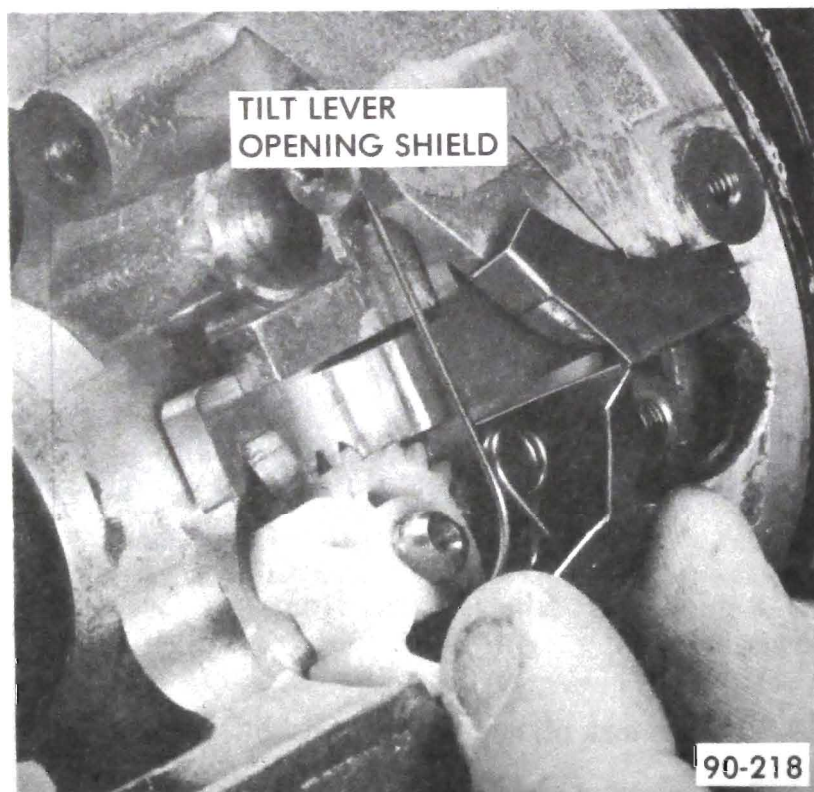

90-218

Figure 90-119 - Removing Tilt Lever Opening Shield

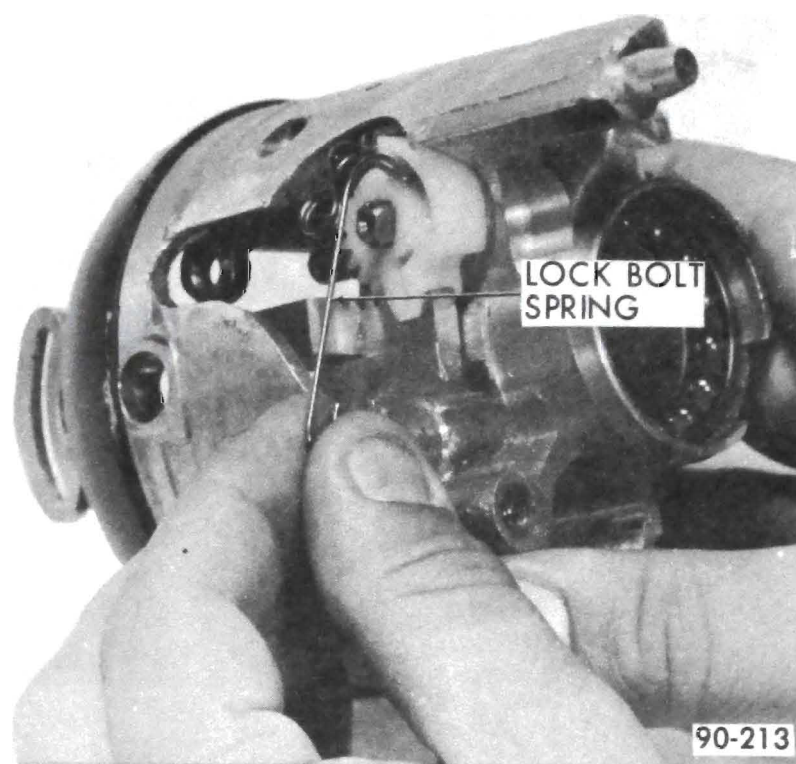

90-213

Figure 90-120 - Removing Lock Bolt Spring

3. Remove snap ring from sector drive shaft. With small punch, lightly tap drive shaft from sector. Remove drive shaft, washer, sector and bolt. Remove rack and rack spring. See Figure 90-121.

4. Remove tilt release lever pin with J-22635 and hammer. Remove lever and release lever spring. (To relieve load on release lever, hold shoes inward and wedge block between top of shoes (over slots) and bearing housing). See Figure 90-122.

5. Remove lock shoe pin with Tool J-22635 and

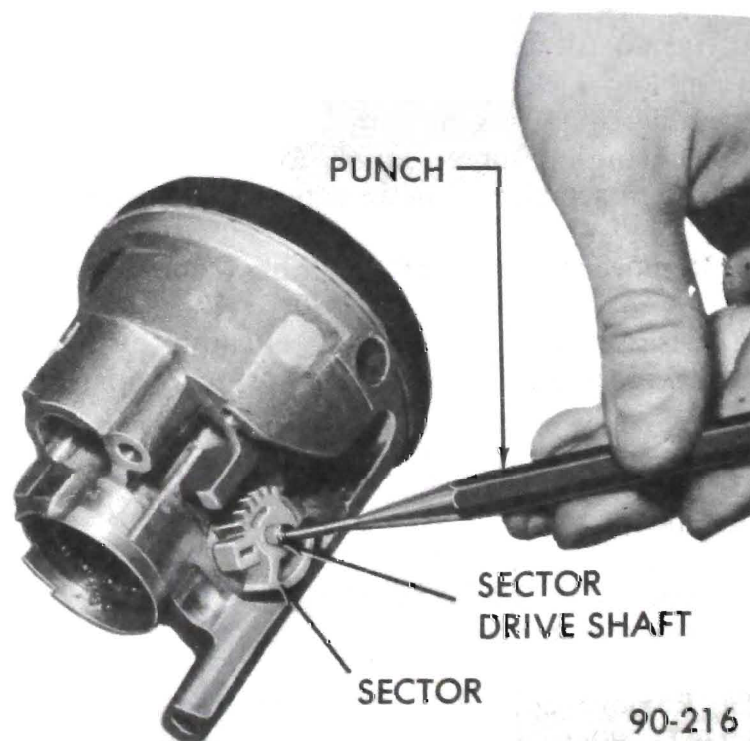

90-216

Figure 90-121 - Removing Sector Drive Shaft.

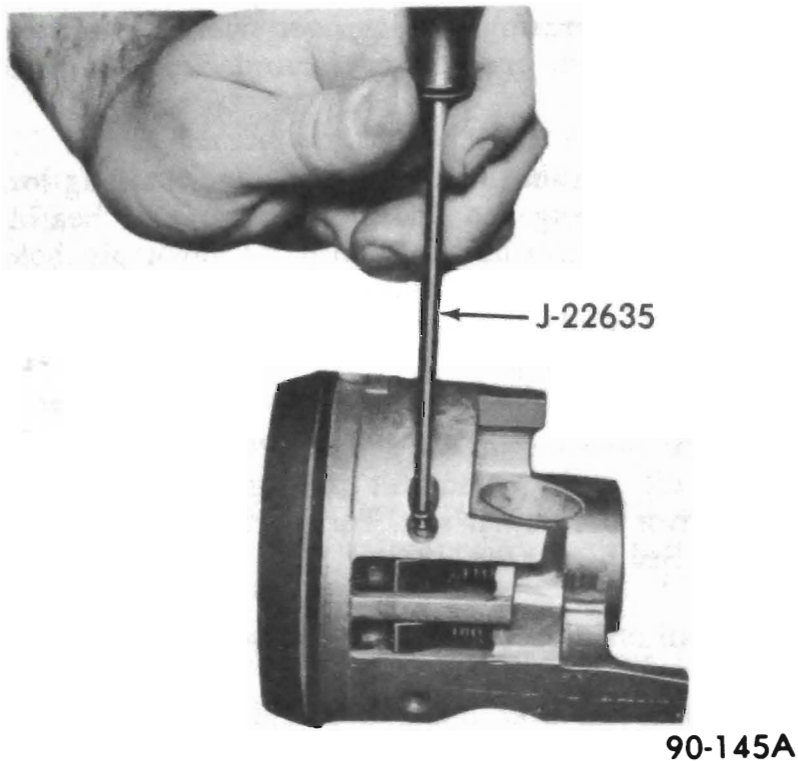

Figure 90-122 - Removing Lock Shoe Pivot Pin

hammer. Remove lock shoes and lock shoe springs. See Figure 90-123.

6. Remove bearings from bearing housing only if they are to be replaced. Remove separator and balls from bearing. Place housing on work surface. With a pointed punch against back surface of race, carefully hammer race out of housing until bearing puller can be used. Repeat for other race.

B. Assembly of Steering Column

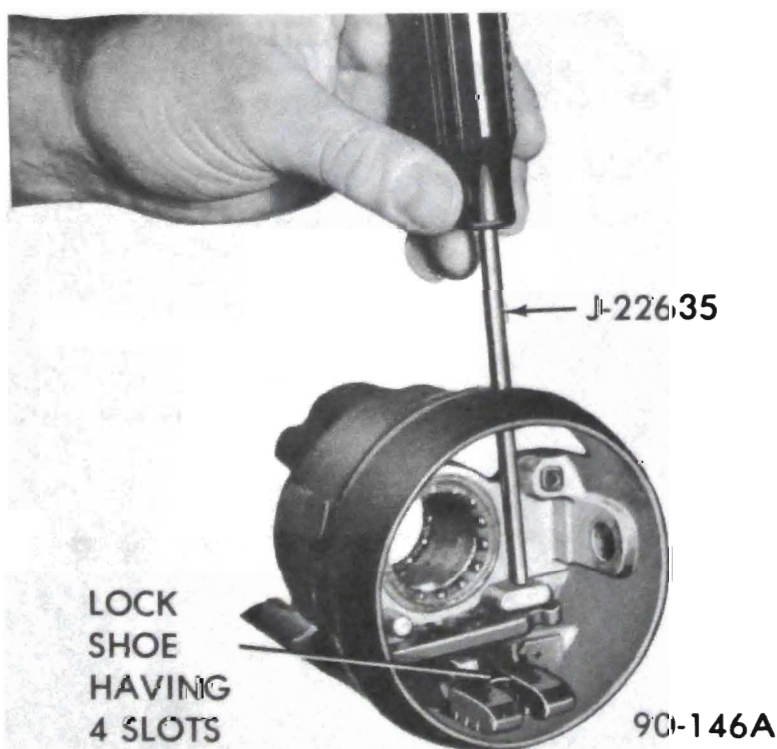

Figure 90-123 - Removing Release Pin

CAUTION: Fasteners in the following steps are important attaching parts in that they could affect the performance of vital components and systems, and/or could result in major repair expense. It must be replaced with one of the same part number or with an equivalent part if replacement becomes necessary. Do not use a replacement part or lesser quality or substitute design. Torque values must be used as specified during reassembly to assure proper retention of this part.

Apply thin coat of E.P. No. 1 Grease to all friction surfaces.

1. Install bearings in bearing housing, if removed.

2. Install lock shoe springs, lock shoe and shoe pin in bearing housing. Use .180 inch diameter rod to line up shoes for pin installation.

3. Install spring, release lever and pin in bearing housing. (Relieve load on release lever as in Step 4 of disassembly procedure.)

4. Install washer and drive shaft in housing. Lightly tap sector onto the shaft far enough to install snap ring.

5. Install lock bolt and engage with sector cam surface. See Figure 90-124.

6. Install rack and spring. Block tooth on rack to engage block tooth on sector. Install external tilt release lever.

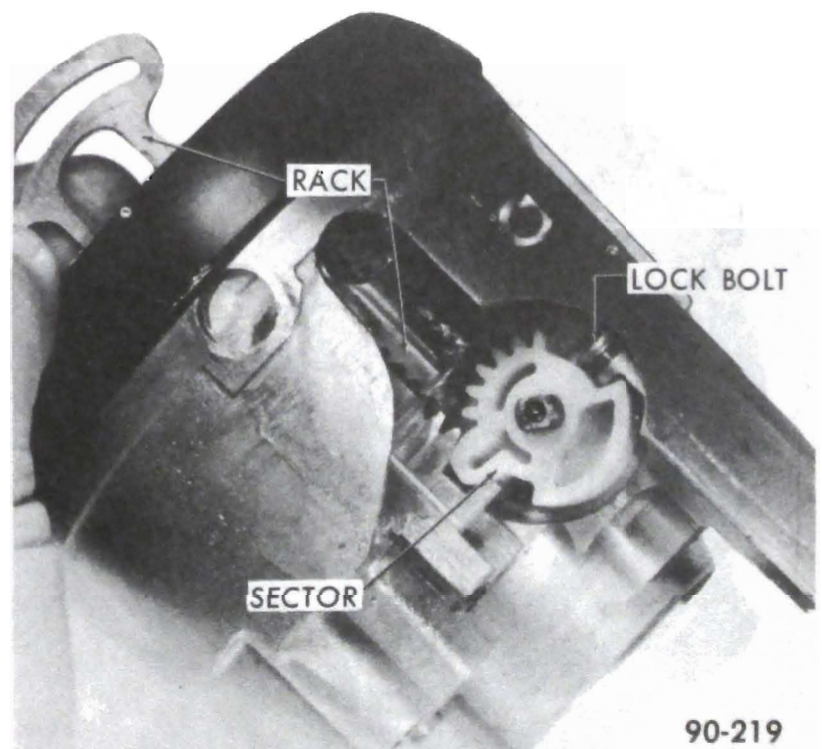

Figure 90-124 - Engaging Block Tooth on Rack to Sector

7. Install bolt spring and spring retaining screw. Torque to 35 pound inch. See Figure 90-120.
8. Install shift lever spring in bowl by winding up with pliers and pushing in. Slide bowl into mast jacket.
9. Install wave washer and lock plate in place. Work lock plate into notches in jacket.
10. Carefully install shift tube in lower end of mast jacket. Align keyway in tube with key in bowl and using Installer J-23073, pull shift tube into bowl. See Figure 90-125. Do not push or tap on end of shift tube.
11. Install thrust washer and retaining ring by pulling bowl up to compress wave washer.
12. Install support by aligning "V" in support with "V" notch in jacket. Insert screws through support in lock plate. Torque screws to 60 pound inch.
13. Align lower bearing adapter notches in jacket and push in lower end of mast jacket. Shift tube should pilot in adapter while this is done. Install clip.
14. Install centering spheres and anti-lash spring in upper steering shaft. Install lower steering shaft from same side of spheres that spring ends protrude.
15. Install steering shaft assembly in shift tube from upper end. Carefully guide shaft through shift tube and bearing.
16. Install ignition switch actuator rod through bowl from bottom and insert in slot in support. Extend rack downward from bearing housing.

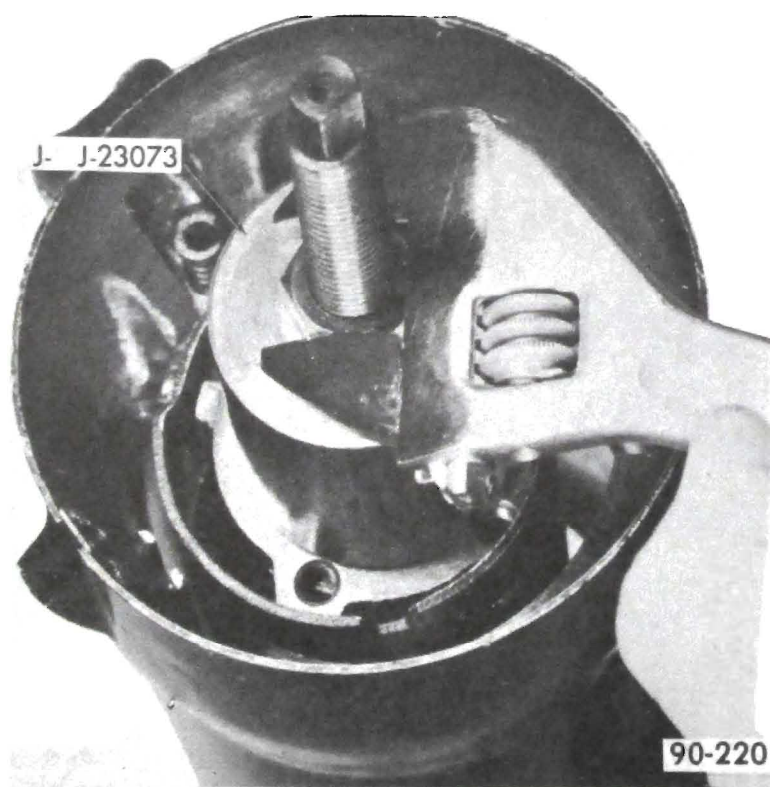

Figure 90-125 - Installing Shift Tube

17. Assemble bearing housing over steering shaft and engage rack over end of actuator rod. See Figure 90-126.
18. Install external tilt release lever and, holding lock shoes in disengaged position, assemble bearing housing over steering shaft until the pivot pin holes line up.
19. Install pivot pins.
20. Place housing in full "Up" position and install guide, tilt spring and tilt spring retainer, using screwdriver in retainer slot. Turn retainer clockwise to engage. See Figure 90-113.
21. Install inner race and inner race seat.
22. Install tilt lever opening shield in housing. See Figure 90-119.
23. Remove tilt release lever, install housing cover and torque three screws to 45 pound inch.
24. Assemble buzzer switch to spring clip with formed end of clip under end of switch and spring bowed away from switch on side opposite contact. Push switch and spring into hole in cover to the step with the contacts toward lock cylinder bore.
25. Install cruise switch wires. Install turn signal switch wires and connector through cover, bearing housing and bowl. Push hazard warning knob in, install switch and torque screws to 35 pound inch. Short screw goes in hole nearest to lock cylinder.

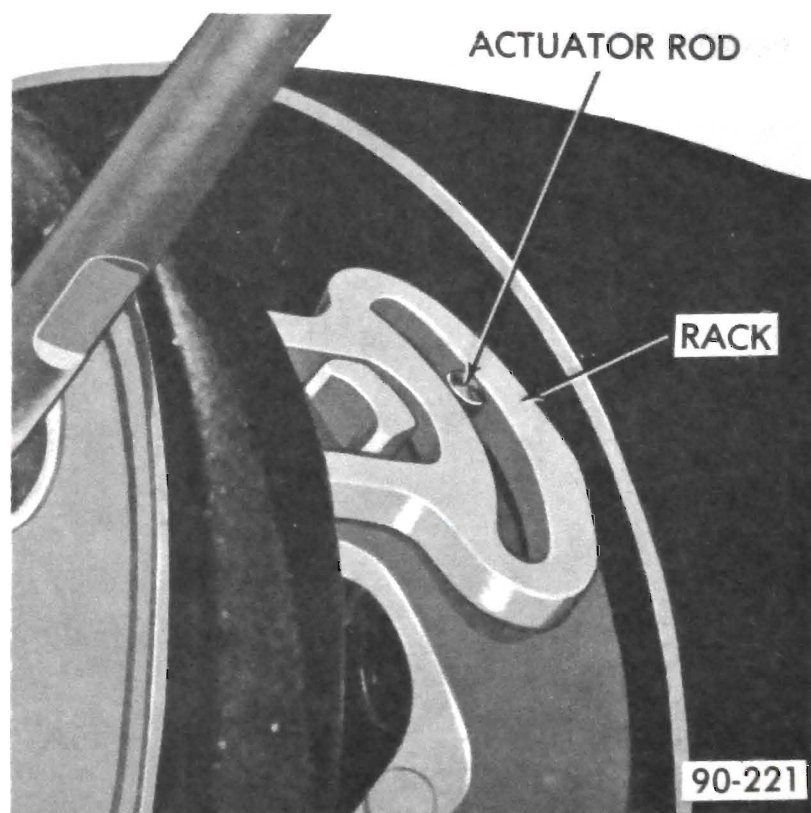

Figure 90-126 - Installing Bearing Housing

26. Install spring, spacer, no-back washer (if one is used) and lower steering shaft flange. Torque flange pinch bolt to 30 pound foot.

27. Install hazard warning knob and pull knob out. Install cancelling cam spring, cancelling cam and shaft lock.

28. Depress shaft lock plate using Tool J-23131 and install a new snap ring in groove on shaft.

The turn signal switch assembly may be damaged if the above procedure is not followed.

29. Install tilt release lever, signal switch lever and hazard warning knob to proper torques. Install upper shift lever and drive in pivot pin.

30. To install lock, hold lock cylinder sleeve and rotate knob clockwise against stop. Insert cylinder into cover bore with key on cylinder sleeve aligned to keyway in housing, push in to abutment of cylinder and sector. Rotate knob counterclockwise, maintaining a light push inward on cylinder, until drive section of cylinder mates with drive shaft. Push in until snap ring pops into groove and lock cylinder is secured in cover. Check freedom of rotation.

31. Install shaft lock cover and torque three screws to 35 lb.in.

32. When installing the ignition switch, be sure the lock cylinder is in "Lock" position. Put bowl or shroud (if floor shift column) in "park" position. Make certain that the ignition switch is in "Lock". Fit actuator rod into switch and assemble to column with two screws. Torque the two screws to 35 lb.in. See Figure 90-128.

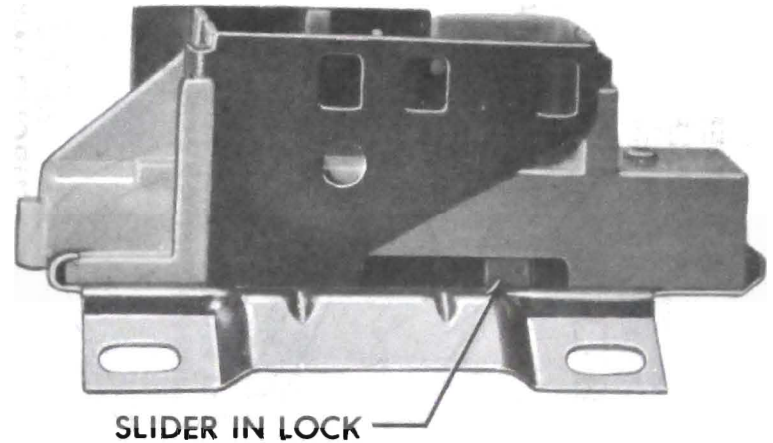

90-222

Figure 90-128 - Ignition Switch Slider in "Lock" Position

33. Install neutral-start back-up light switch. Do not tighten screws. Neutral-start switch will be adjusted in the car.

34. Install wire protector over wires and on mast jacket. Install mounting bracket. See Figure 90 110.

35. Install steering wheel. Torque steering wheel nut to specified torque. Install horn actuator parts.

36. Adjust neutral-start back-up light switch with shift lever in "Drive" position.

DIVISION VI

SPECIFICATIONS

90-27 SPECIFICATIONS

Part	Location	Torque Ft.Lbs.
Nut	Steering Wheel Hub	35
Bolt	Mounting Bracket to Steering Column	15
Nuts	Flexible Coupling Halves	20
Bolt	Flexible Coupling Upper Half to Lower Half	20
Nuts	Mounting Bracket to Instrument Panel	20

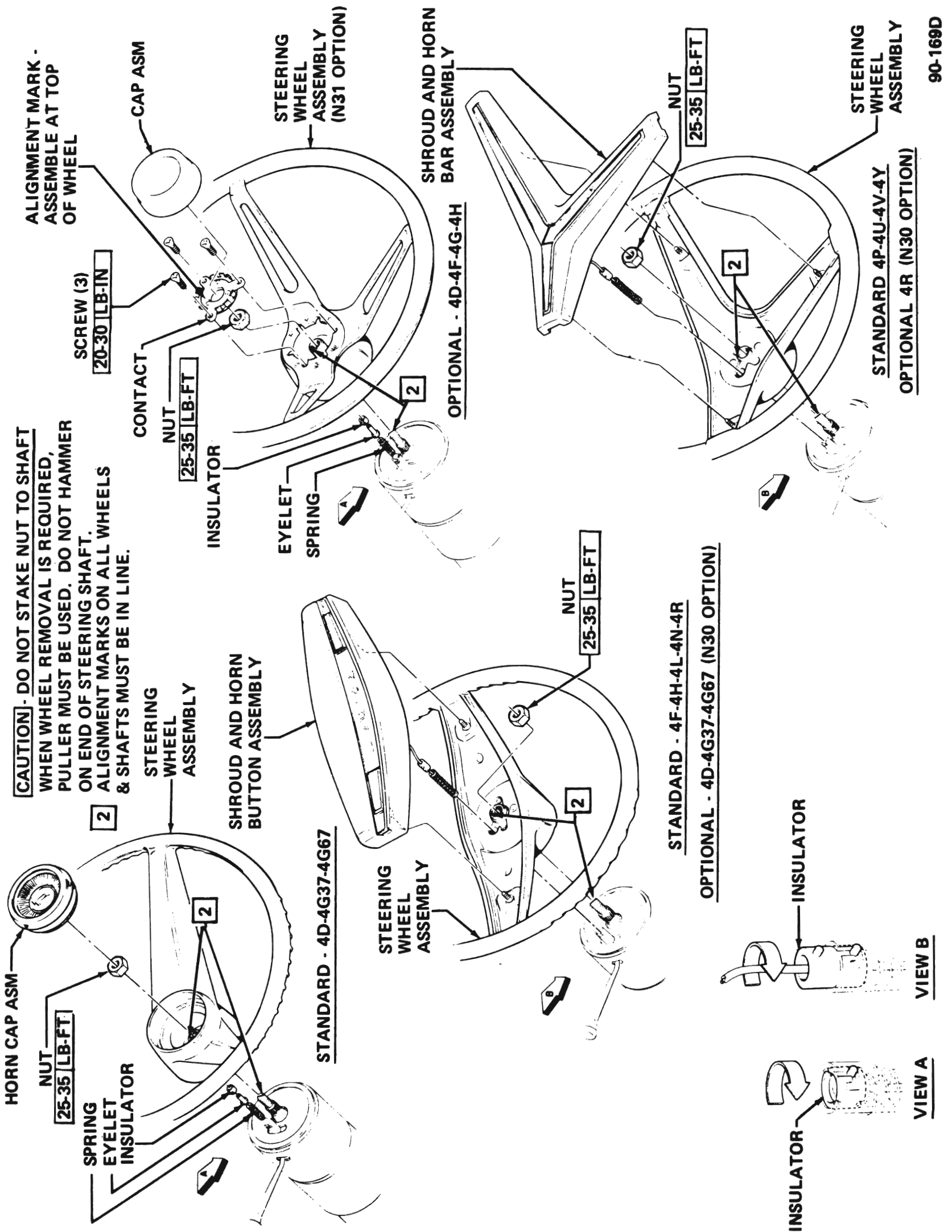

Figure 90-129 Steering Wheel Installation

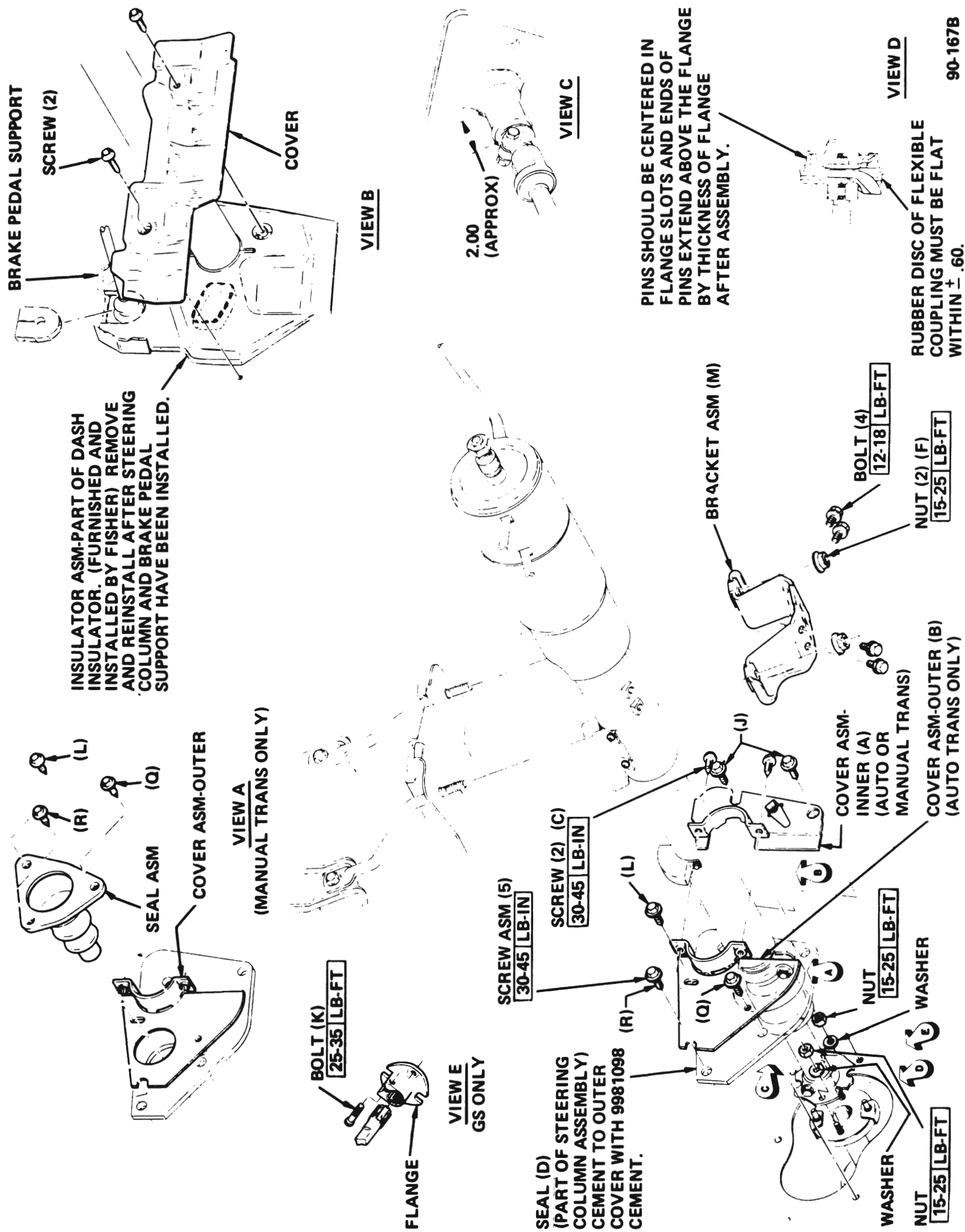
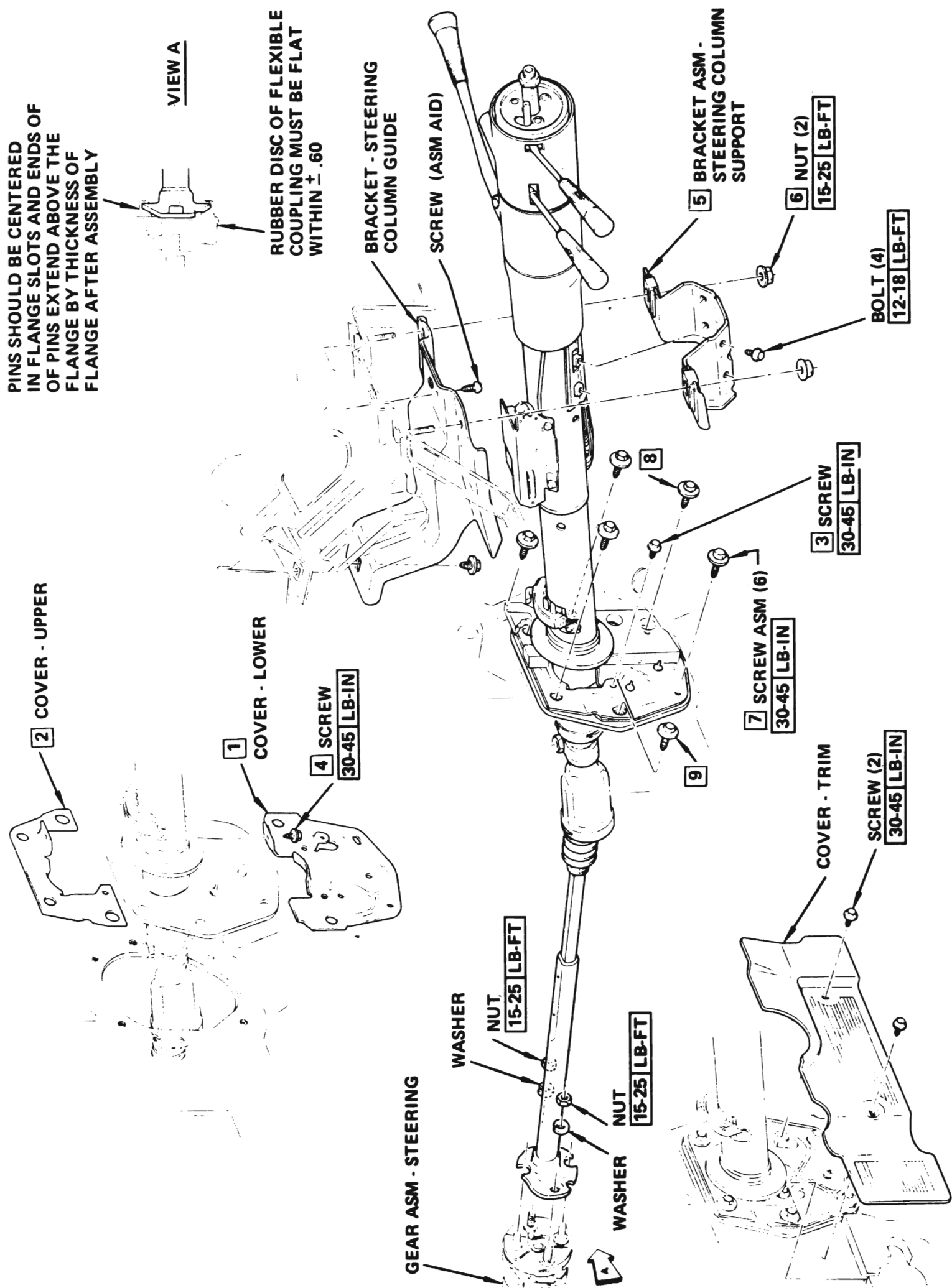
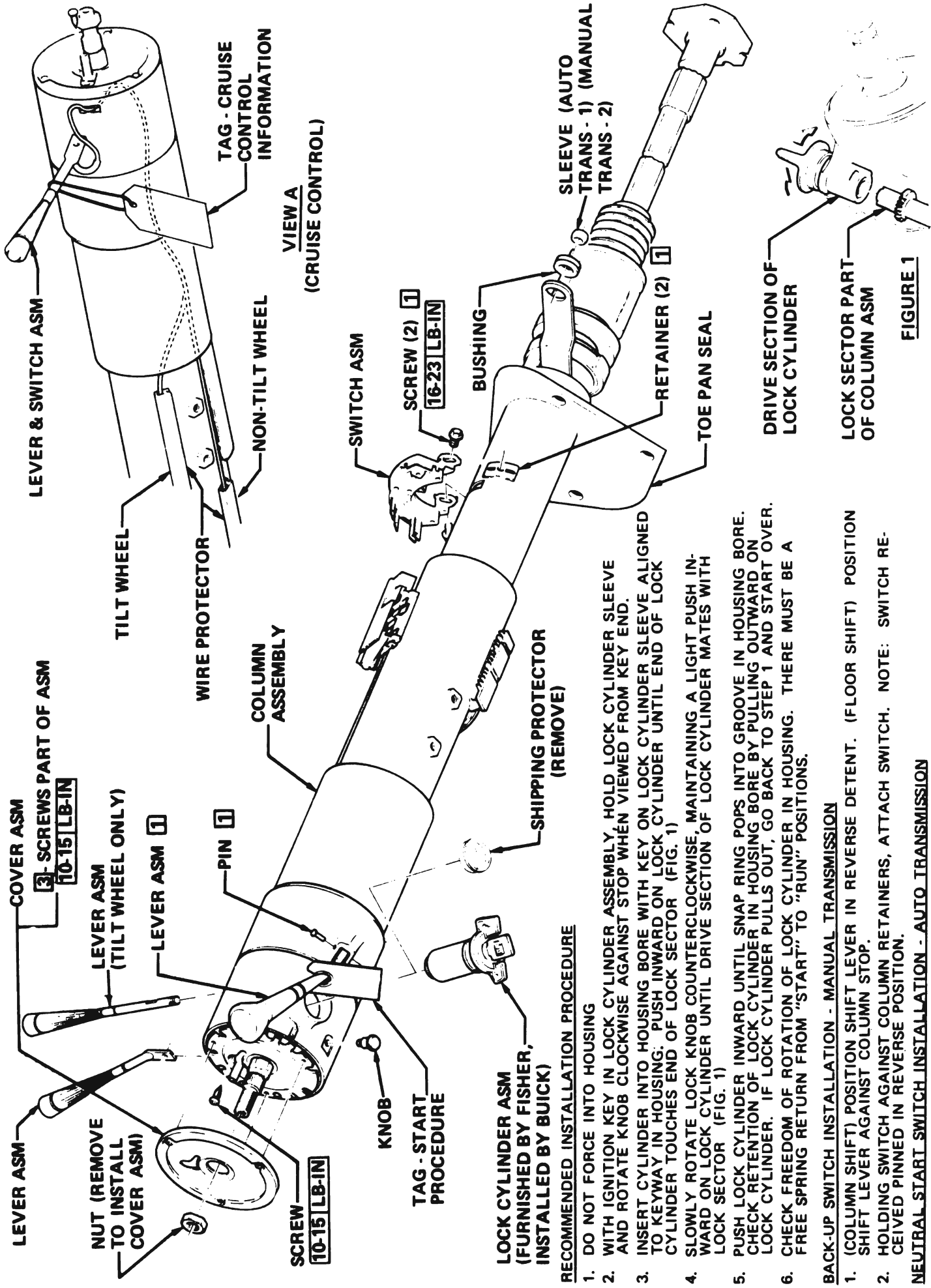

Figure 90-130 - 4D-4F-4G-4H Steering Column Installation



90-165B

Figure 90-131 - 4L-4N-4R-4P-4U-4V-4Y Steering Column Installation and Upper Controls



- LOCK CYLINDER ASM (FURNISHED BY FISHER, INSTALLED BY BUICK)**
- RECOMMENDED INSTALLATION PROCEDURE**
1. DO NOT FORCE INTO HOUSING
 2. WITH IGNITION KEY IN LOCK CYLINDER ASSEMBLY, HOLD LOCK CYLINDER SLEEVE AND ROTATE KNOB CLOCKWISE AGAINST STOP WHEN VIEWED FROM KEY END.
 3. INSERT CYLINDER INTO HOUSING BORE WITH KEY ON LOCK CYLINDER SLEEVE ALIGNED TO KEYWAY IN HOUSING; PUSH INWARD ON LOCK CYLINDER UNTIL END OF LOCK CYLINDER TOUCHES END OF LOCK SECTOR (FIG. 1)
 4. SLOWLY ROTATE LOCK KNOB COUNTERCLOCKWISE, MAINTAINING A LIGHT PUSH INWARD ON LOCK CYLINDER UNTIL DRIVE SECTION OF LOCK CYLINDER MATES WITH LOCK SECTOR (FIG. 1)
 5. PUSH LOCK CYLINDER INWARD UNTIL SNAP RING POPS INTO GROOVE IN HOUSING BORE. CHECK RETENTION OF LOCK CYLINDER IN HOUSING BORE BY PULLING OUTWARD ON LOCK CYLINDER. IF LOCK CYLINDER PULLS OUT, GO BACK TO STEP 1 AND START OVER.
 6. CHECK FREEDOM OF ROTATION OF LOCK CYLINDER IN HOUSING. THERE MUST BE A FREE SPRING RETURN FROM "START" TO "RUN" POSITIONS.
- BACK-UP SWITCH INSTALLATION - MANUAL TRANSMISSION**
1. (COLUMN SHIFT) POSITION SHIFT LEVER IN REVERSE DETENT. (FLOOR SHIFT) POSITION SHIFT LEVER AGAINST COLUMN STOP.
 2. HOLDING SWITCH AGAINST COLUMN RETAINERS, ATTACH SWITCH. NOTE: SWITCH RECEIVED PINNED IN REVERSE POSITION.
- NEUTRAL START SWITCH INSTALLATION - AUTO TRANSMISSION**
1. POSITION AND RETAIN GEAR SHIFT LEVER IN NEUTRAL NOTCH IN COLUMN DETENT.
 2. SEAT SWITCH FULLY ON COLUMN.
 3. SECURE SWITCH WITH SCREWS TO SPECIFIED TORQUE. NOTE: SWITCHES ARE RECEIVED PINNED IN "NEUTRAL" POSITION. PIN WILL BREAK WITH FIRST SHIFT MOVEMENT. "NEUTRAL" IS LOCATED AFTER PIN IS BROKEN BY INSERTING A .092 DIA. PIN THROUGH THE SERVICE HOLE (MARKED "N") AND THE SUPPORT.

Figure 90-132 Steering Column and Upper Controls - 4D-4F-4G-4H Series

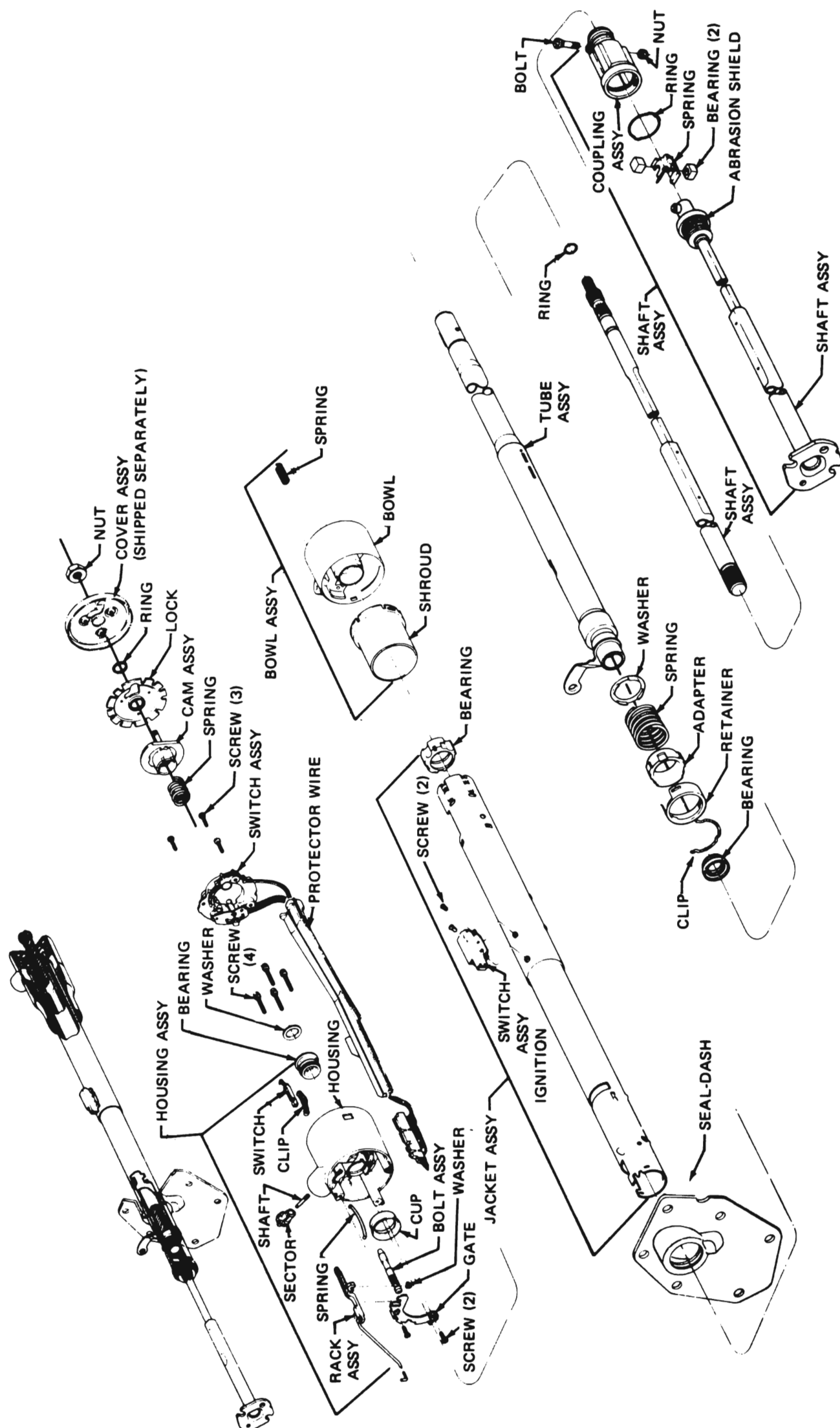

90-138E

Figure 90-134 All Series Standard Steering Column

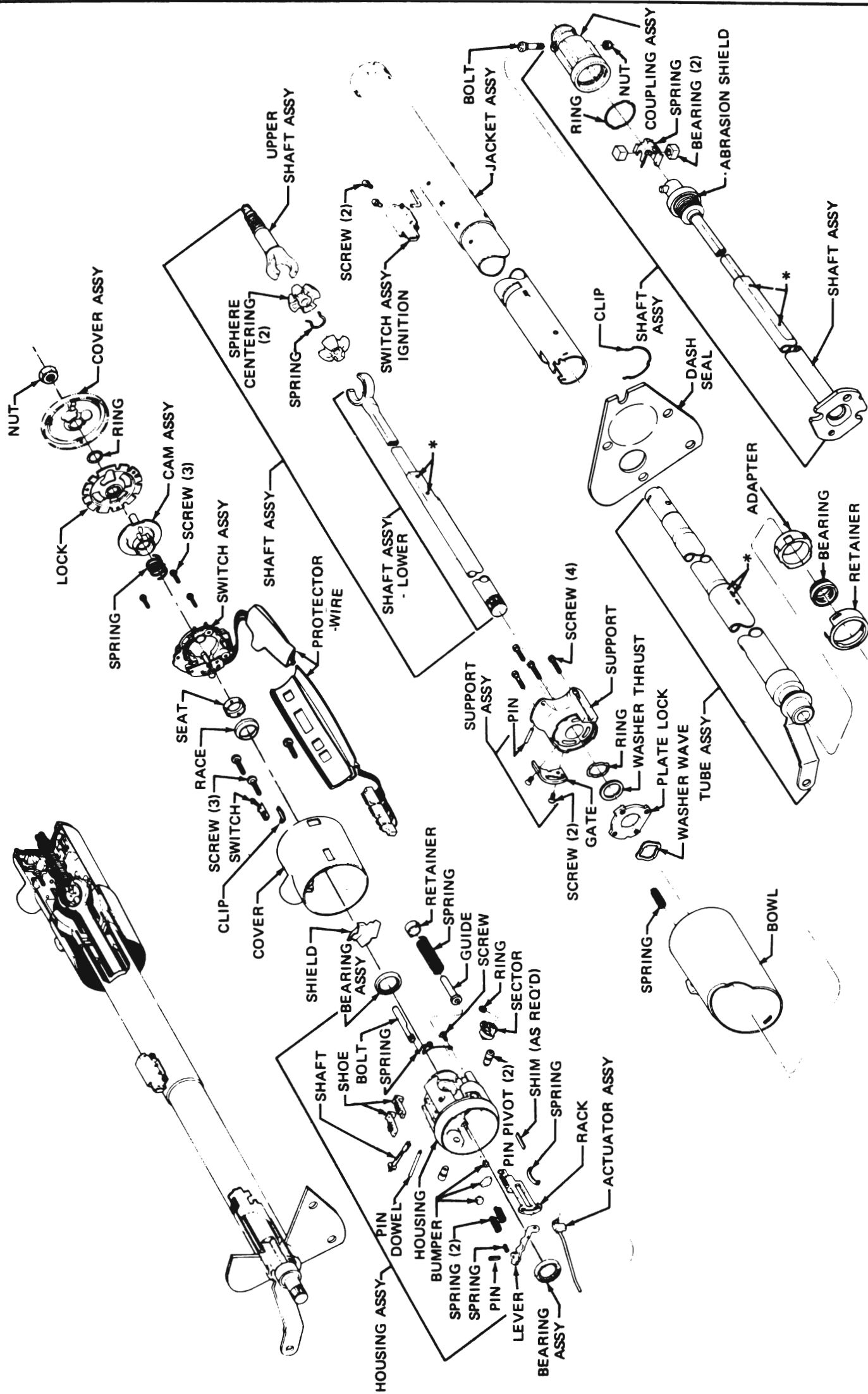

90-147E

Figure 90-135 Tilt Steering Column - Typical

4D-4F-4G-4H STEERING COLUMN

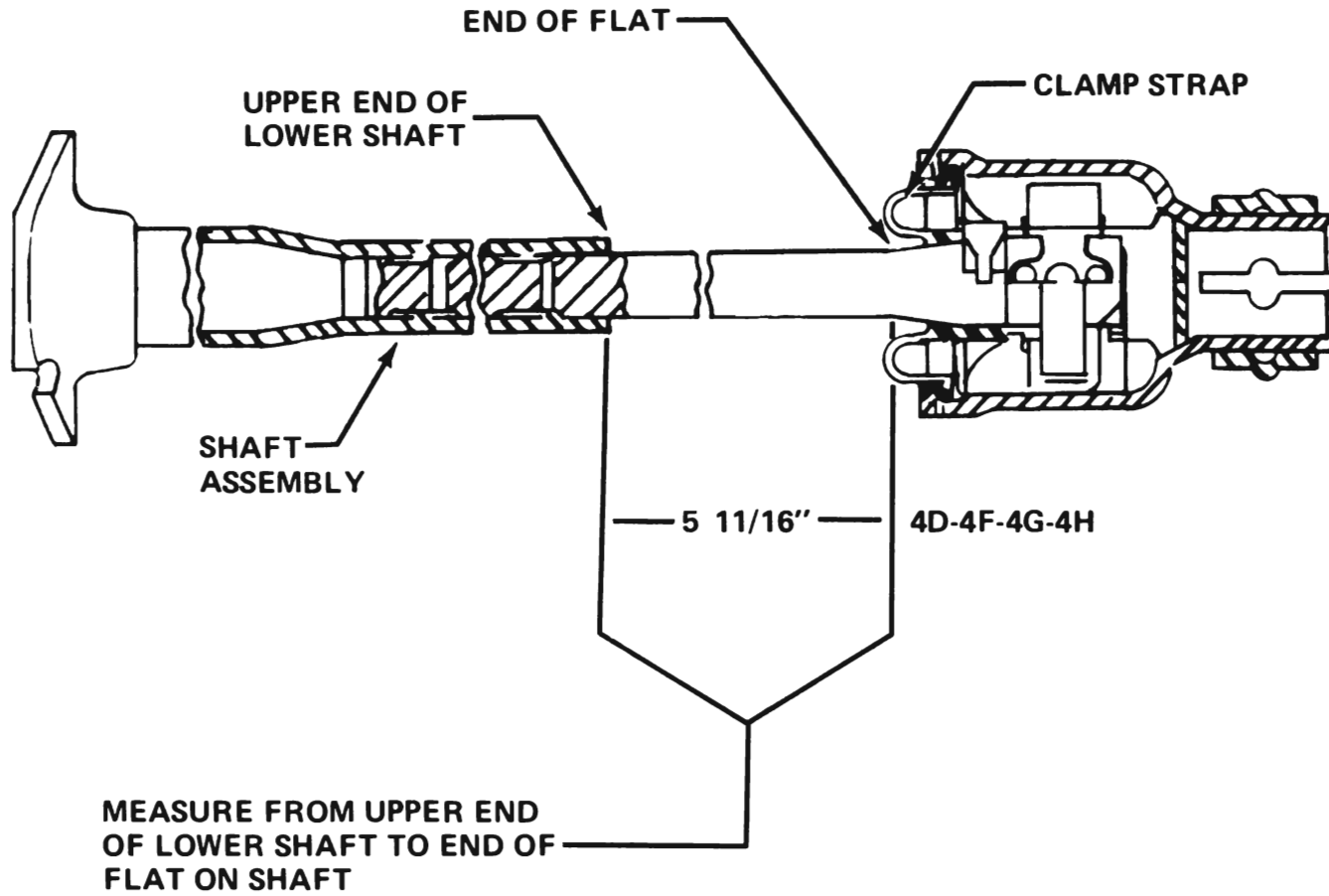

4L-4N-4R-4P-4U-4V-4Y STEERING COLUMN

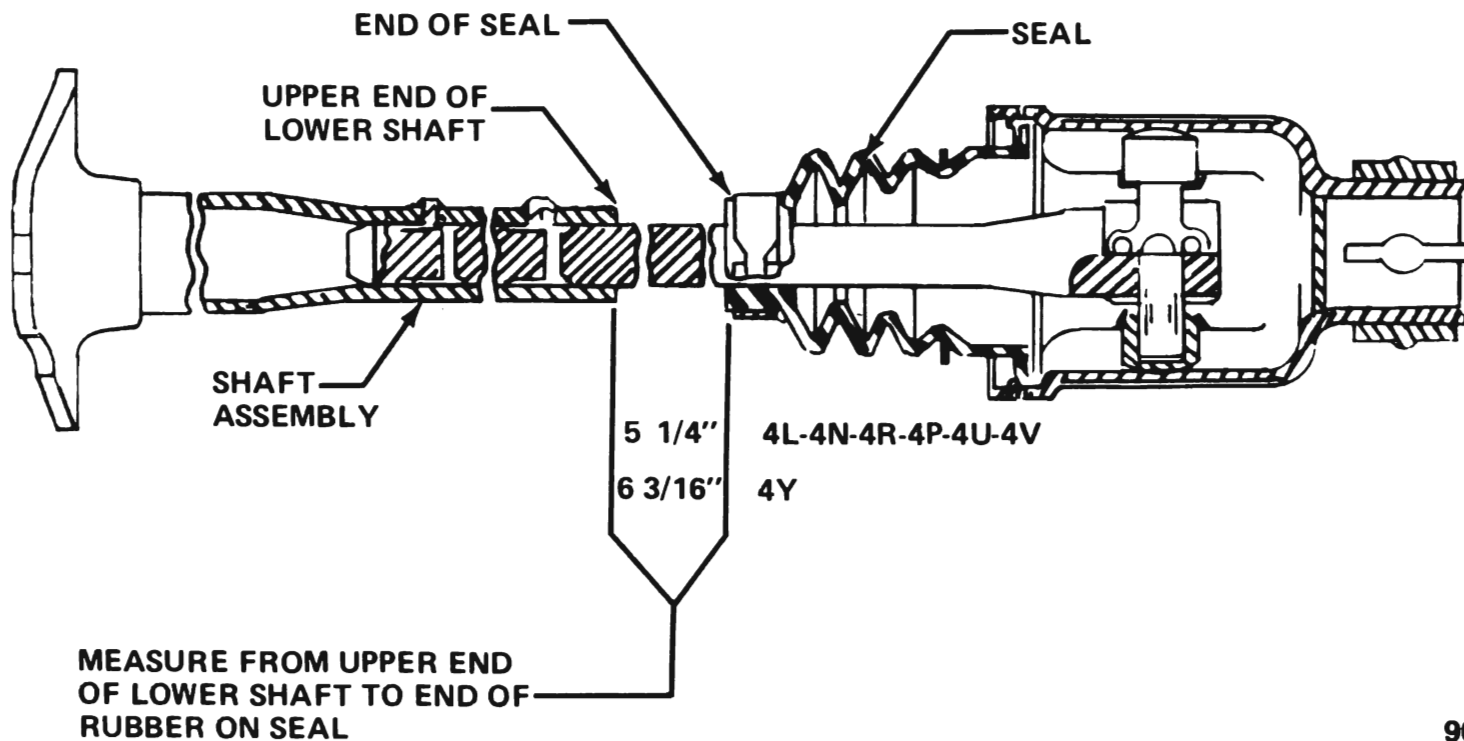

Figure 90-136