

SECTION A

MANUAL STEERING GEAR

4D-4F-4G-4H SERIES

CONTENTS

Division	Subject	Page No.
I	TROUBLE DIAGNOSIS: Trouble Diagnosis	90-2
II	DESCRIPTION AND OPERATION: Description of Manual Steering Gear	90-3
III	ADJUSTMENTS AND MINOR SERVICE: Adjustment of Manual Steering Gear	90-3
IV	REMOVAL AND INSTALLATION: Removal and Installation of Manual Steering Gear Assembly	90-5
V	OVERHAUL AND MAJOR SERVICE: Disassembly, Inspection and Reassembly of Manual Steering Gear	90-5
VI	SPECIFICATIONS: Manual Steering Gear Specifications	90-9

DIVISION I

TROUBLE DIAGNOSIS

90-1 TROUBLE DIAGNOSIS

Condition and Possible Cause	Correction
1. Excessive play or looseness in steering system.	1. a) Front wheel bearings loosely adjusted. See Group 30. b) Worn upper ball joints. See Group 30. c) Steering wheel loose on shaft, loose pitman arm, tie rods, steering arms or steering linkage ball studs. d) Excessive pitman shaft to ball nut lash. e) Worm bearings loosely adjusted.

-
2. Hard steering - excessive effort required at steering wheel.
2. a) Low or uneven tire pressure.
 b) Insufficient or improper lubricant in steering gear or front suspension.
 c) Steering shaft flexible coupling misaligned.
 d) Steering gear adjusted too tight.
 e) Front wheel alignment incorrect.
-
3. Rattle or chuck in steering gear.
3. a) Insufficient or improper lubricant in steering gear.
 b) Excessive lash between ball nut and pitman shaft in straight ahead position or worm thrust bearings adjusted too loose.
 NOTE: On turns a slight rattle may occur due to the increased lash between ball nut and pitman shaft as gear moves off the center of "high point" position. This is normal and lash must not be reduced to eliminate this slight rattle.
 c) Pitman arm loose on shaft or steering gear mounting bolts loose.
 d) Loose or worn steering shaft bearing.
-
4. Poor returnability.
4. a) Steering gear adjusted too tight.
 b) Front wheel alignment incorrect.
 c) Insufficient or improper lubricant in steering gear or front suspension.
 d) Steering column misaligned.
-

DIVISION II

DESCRIPTION AND OPERATION

90-2 DESCRIPTION OF MANUAL STEERING GEAR

The steering gear is the recirculating ball worm and nut type. The worm is located on the lower end of the steering shaft. The ball nut is mounted on the worm and has mating spiral grooves in which steel balls circulate to provide a low-friction drive between worm and nut (See Figure 90-1).

Teeth on the ball nut engage teeth on the pitman shaft sector. The teeth on the ball nut are made so that a "high point" or tighter fit exists between the ball nut and pitman shaft sector teeth when front wheels are in the straight-ahead position. The sector teeth are slightly tapered so that a proper lash may be obtained by moving the pitman shaft endways by means of a lash adjuster screw which extends through the gear

housing side cover. The head of the lash adjuster and a selectively fitted shim fit snugly into a T-slot in the end of the pitman shaft, so that the screw also controls end play of shaft. See Figure 90-2.

DIVISION III

ADJUSTMENTS AND MINOR SERVICE

90-3 ADJUSTMENT OF MANUAL STEERING GEAR

A. Adjustment of Steering Gear Out of Car

The steering wheel should turn freely and smoothly through entire range. Roughness indicates faulty internal parts, requiring disassembly of the steering gear. Hard pull or binding indicates an excessively tight adjustment of worm bearings, or excessive misalignment of steering shaft. Any excessive

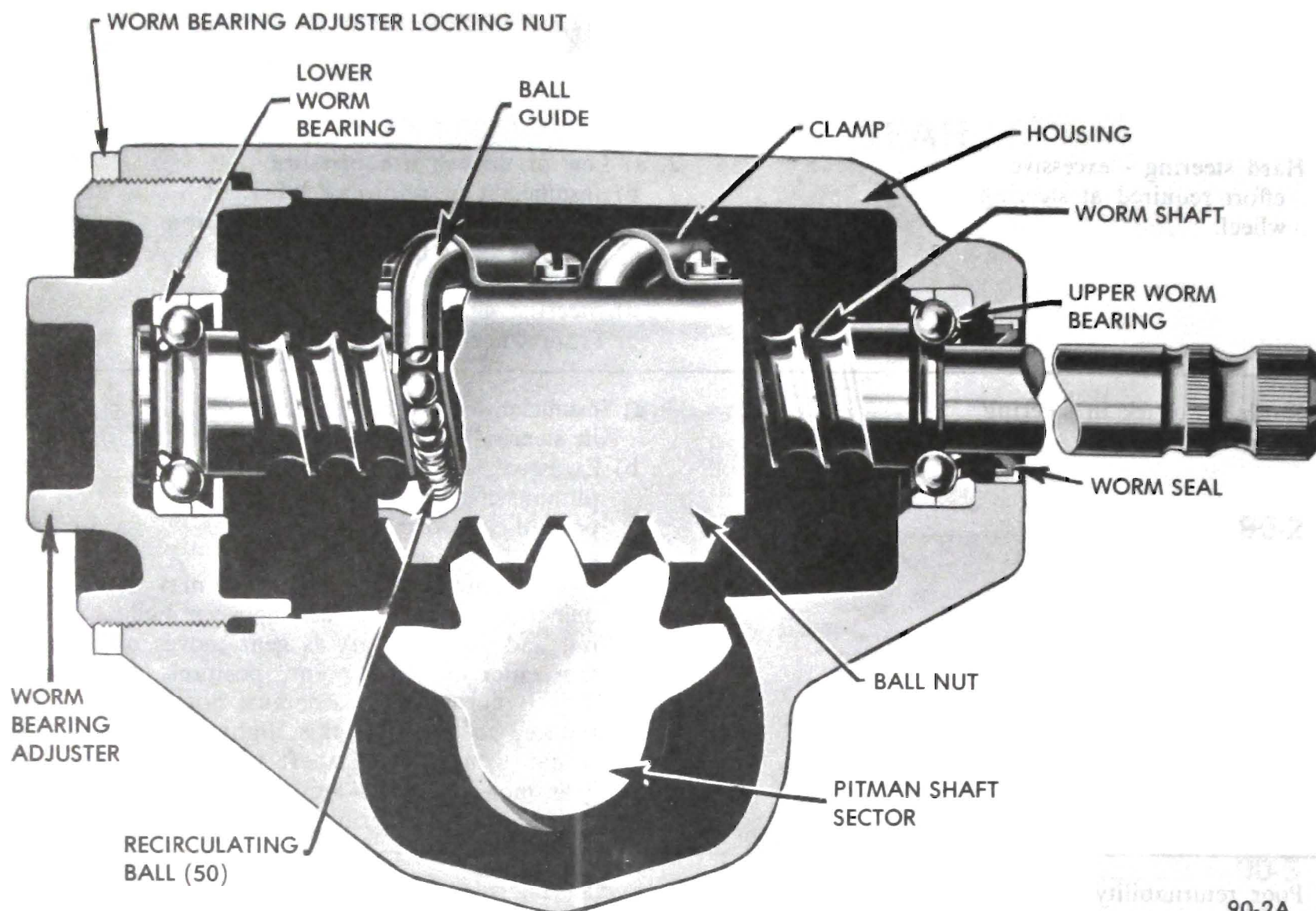

Figure 90-1 Steering Gear Worm and Ball Nut

misalignment must be corrected before steering gear can be properly adjusted.

1. With steering gear removed from car.
2. Attach inch-pound torque wrench (J-5853) to worm shaft and rotate shaft to extreme right or left position. See Figure 90-3. Never turn the wheel hard against the stopping point in the gear, as damage to the ball nut assembly may result.
3. Rotate worm shaft in opposite direction and adjust worm bearing adjuster to obtain a reading of 2 to 7 pound inches with worm shaft turning slowly. Worm bearing preload measurement must be made within 1/2 turn of worm shaft from extreme position.
4. Tighten worm bearing adjuster lock nut and recheck reading.
5. Turn worm shaft from one extreme to the other while counting turns, then turn back 1/2 the total number of turns. This places the steering gear on the "overcenter" or "high point" position.

6. Loosen pitman shaft lash adjuster locking nut and turn lash adjuster until a reading of 5 to 11 pound inches higher than worm bearing preload is obtained while rotating worm shaft through the "overcenter" range. Tighten lock nut and recheck reading. Total "overcenter" reading should not exceed 18 pound inches.

B. Road Test After Adjustment

Road test car for ease of steering. If steering gear was adjusted to specified limits and hard steering exists, the front suspension members should be checked for lubrication and alignment. Tire inflation pressures should also be checked. When the car is moving straight ahead, the steering wheel should be in the straight-ahead position, or not over 5/8" to either side of the straight-ahead position. If steering wheel is too far to either side, check wheel for proper position on steering shaft and check tie rods for equal adjustment and toe-in. It is important to have the steering gear in the no-lash range when car is moving straight forward.

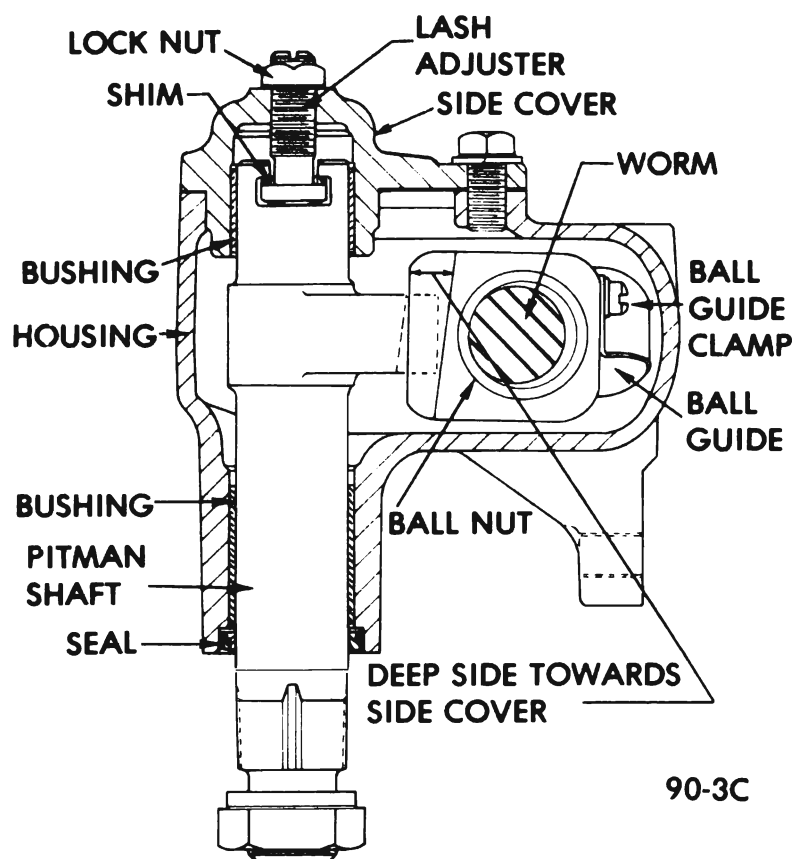

Figure 90-2 Steering Gear - Sectional View

DIVISION IV

REMOVAL AND INSTALLATION

90-4 REMOVAL AND INSTALLATION OF MANUAL GEAR ASSEMBLY

A. Removal of Steering Gear

1. Remove pinch bolt securing flexible coupling flange to steering gear stub shaft.
2. Remove pitman arm retaining nut and remove pitman arm from gear using Puller J-5504. When removing pitman arm from pitman shaft, do not hammer on end of puller as damage will result to gear. If necessary, tapping on side of pitman arm may help in removing arm.
3. Remove three steering gear to frame bolts and remove gear assembly. See Figure 90-4.

B. Installation of Steering Gear

CAUTION: ;Fasteners in steps 1, 2, and 3 are important attaching parts in that they could affect the performance of vital components and systems, and/or could result in major repair expense. They must be replaced with one of the same part number or with an equivalent part if replacement becomes necessary. Do not use a replacement part or lesser

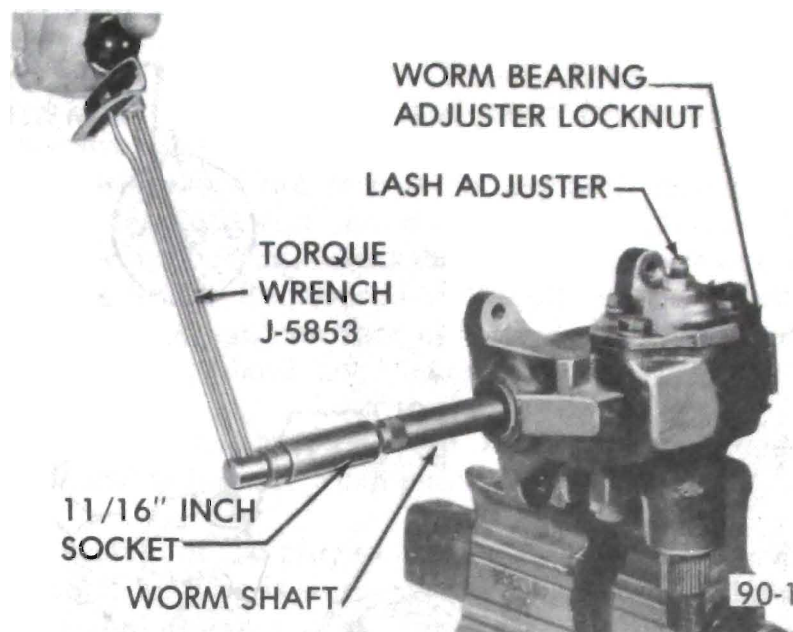

Figure 90-3 Checking Adjustments on Bench

quality or substitute design. Torque values must be used as specified during reassembly to assure proper retention of these parts.

Be sure to reinstall coupling flange so that tab on coupling flange is aligned with mark on gear stub shaft. See Figure 90-5.

1. Align flexible coupling flange to steering gear stub shaft and install gear assembly to frame. Tighten gear to frame bolts to 70 lb.ft.
2. Install pinch bolt in flange and tighten to 30 lb.ft.
3. Reconnect pitman arm to pitman shaft and torque pitman arm retaining nut to 160-210 lb. ft.

DIVISION V

OVERHAUL AND MAJOR SERVICE

90-5 DISASSEMBLY, INSPECTION, AND REASSEMBLY OF MANUAL STEERING GEAR

A. Disassembly

It is not necessary to disassemble gear to replace worm seal. Remove worm seal with an awl being careful not to damage housing or shaft and install a new seal with installer J-8564. See Figure 90-6.

1. Thoroughly clean exterior of gear assembly with a suitable solvent.
2. Place steering gear in a soft jaw vise.

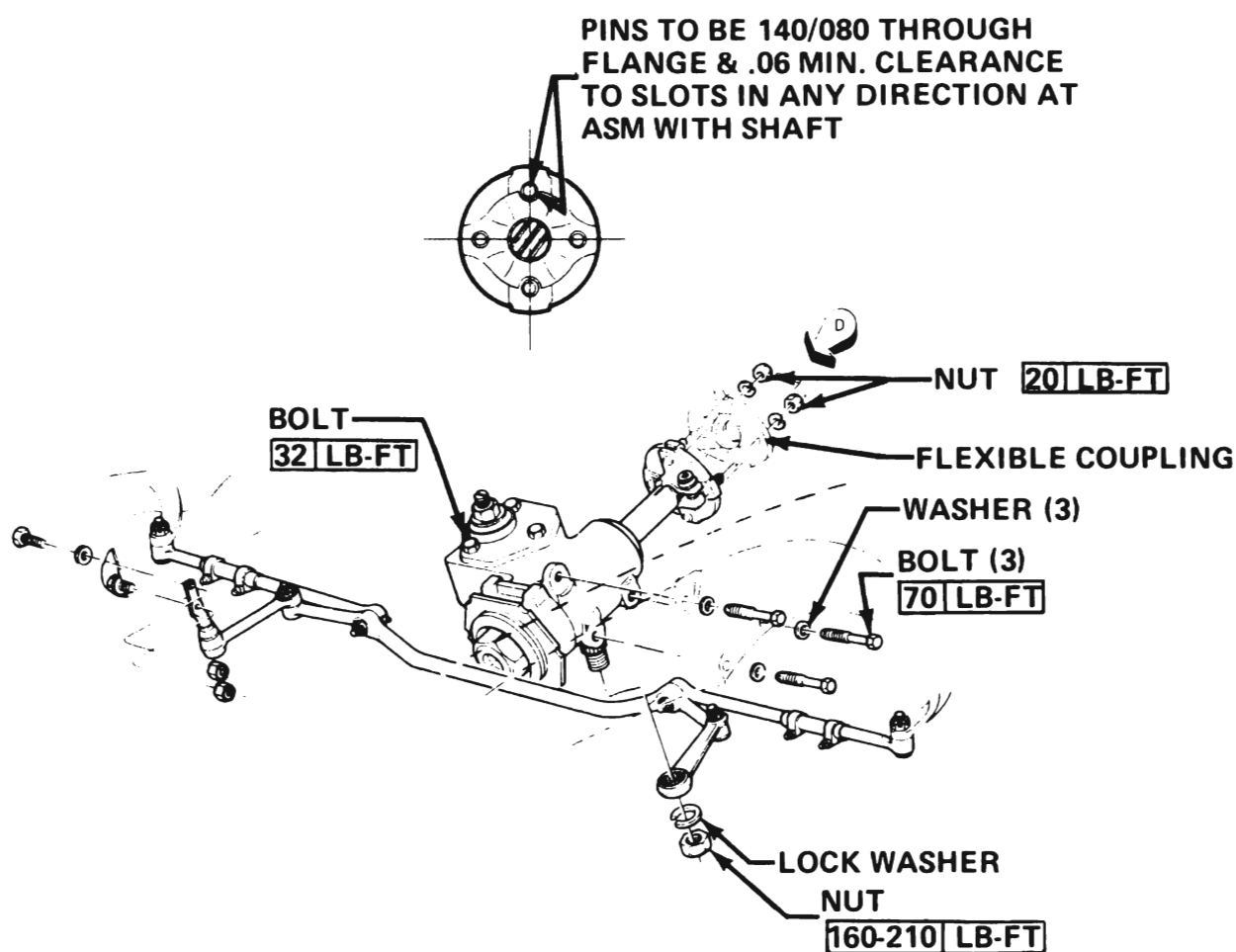

90-110B

Figure 90-4 Manual Steering Gear Installation

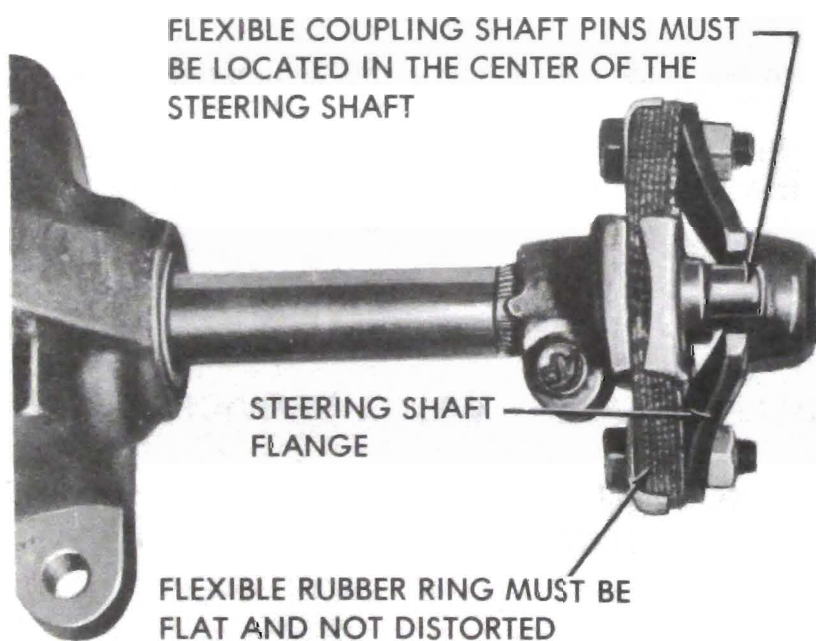

90-12B

Figure 90-5 Steering Gear Flexible Coupling Installation

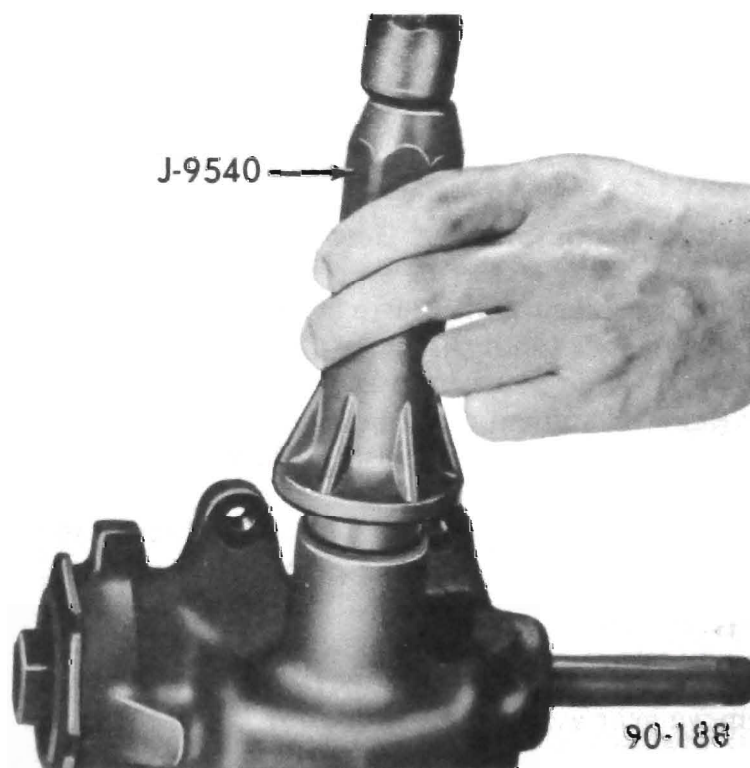

90-188

Figure 90-6 Installing Pitman Shaft Seal - Shaft Installed

If only pitman shaft seal is going to be replaced do not disassemble pitman shaft and side cover, but remove seal with an awl and install seal using Installer J-9540.

Seal is to be installed flush with housing. See Figure 90-6.

3. Rotate worm shaft to center of travel, approximately 3 turns from either extreme.
4. Remove pitman shaft lash adjuster lock nut. Remove three side cover bolts.
5. Remove side cover by turning lash adjuster clockwise through cover. Slip lash adjuster with shim from slot end of pitman shaft. Remove and discard side cover gasket.
6. Remove pitman shaft from housing by lightly tapping on spline end with a soft mallet. Pry pitman shaft seal out of housing with a screwdriver. Discard seal.
7. Loosen worm bearing adjuster lock nut with a punch and remove worm bearing adjuster and lock nut.
8. Remove worm shaft and ball nut assembly, and upper worm bearing from housing. Do not remove upper worm bearing race unless it is to be replaced.
9. Remove lower worm bearing from adjuster by prying retainer out with a screwdriver. See Figure 90-7.
10. Remove ball return guide clamp and guides from ball nut. Turn ball nut over and rotate worm shaft back and forth until all balls (50) drop out into a clean cloth. Remove ball nut from worm shaft.
11. Pry worm shaft seal from housing with screwdriver. Discard seal.

B. Inspection of Steering Gear

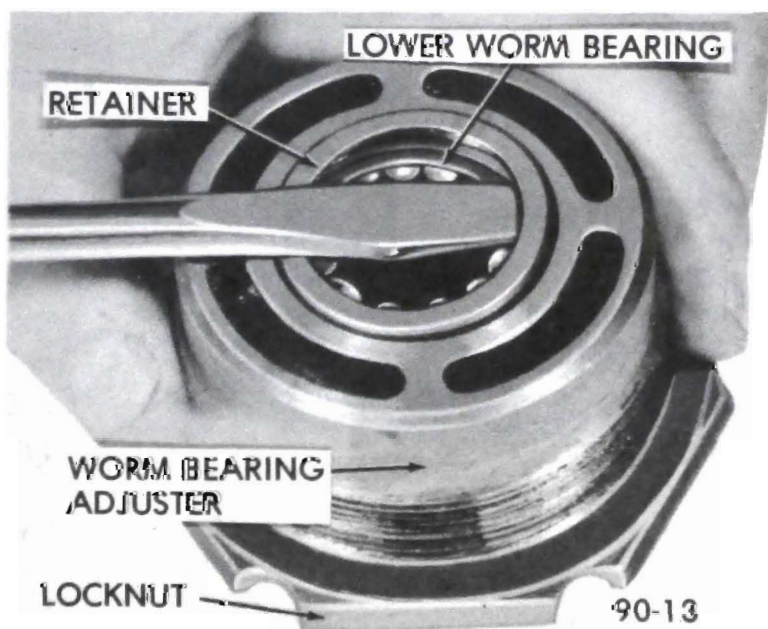

Figure 90-7 Removing Lower Worm Bearing Retainer

1. Wash all parts in clean solvent and wipe dry with a clean cloth.
 2. Inspect worm bearings and races for damage or excessive wear. Replace bearings if necessary. The lower worm bearing race is not replaced separately, but is serviced with the worm bearing adjuster. If upper worm bearing race is defective, drive race out of housing using Remover J-8810 with driver handle J-8092 and install new race using Installer J-8811 with driver handle J-8092. See Figure 90-8.
- Installer J-8811 may be used for installing pitman shaft seal in housing when pitman shaft is removed.
3. Check fit of the pitman shaft in the bushing of side cover. If bushing is worn, side cover must be replaced as bushing is not serviced separately.
 4. Inspect the worm and nut balls and the grooves of worm and nut for damage or excessive wear. Replace parts as necessary.
 5. Inspect teeth of ball nut and pitman shaft for pitting or scoring which would require replacement of ball nut or pitman shaft. Inspect pitman shaft bushing in housing for excessive wear or scoring. If necessary, remove pitman shaft bushing using Remover J-8810 and driver handle J-8092. Install new bushing using Installer J-8811 with driver handle J-8092. See Figure 90-9.
 6. Check pitman shaft surface for wear or scoring, then check fit of pitman shaft lash adjuster and shim in the slot in end of pitman shaft by inserting feeler gauge between the head of screw and bottom of slot. Adjuster must be free to turn and end play should not

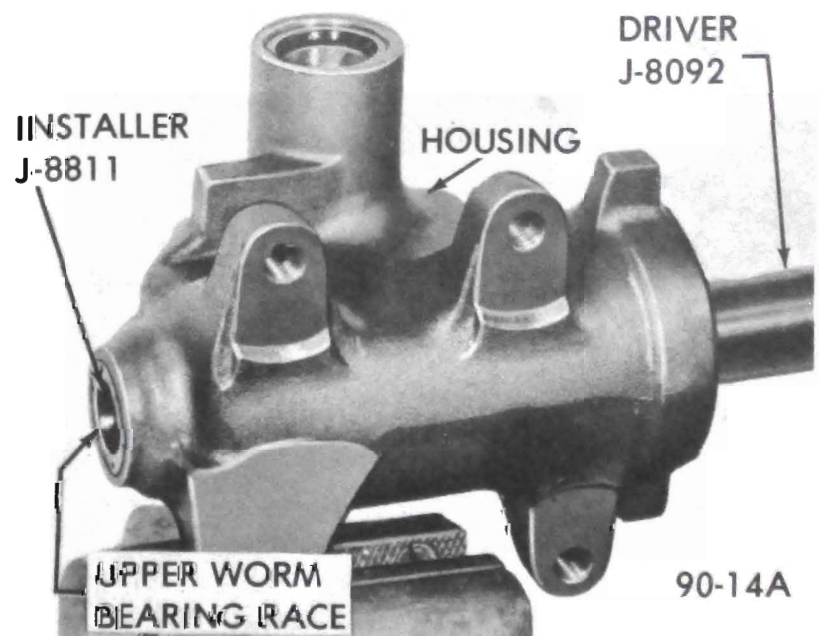

Figure 90-8 Installing Upper Worm Bearing Race

exceed .002". If end play exceeds .002" install proper shim. The shims are available in four different thicknesses -- .063", .065", .067", and .069".

7. Check ball guides for damage and replace if necessary.

C. Assembly of Steering Gear

Lubricate all seals, bushings, bearings and gears with calcium soap No. 2 just before assembling.

1. Position ball nut over worm shaft so that deep side of teeth will be toward side cover when installed in gear housing. See Figure 90-2. Install 19 balls in each circuit (rock worm shaft slightly to aid in installing balls). Place 6 balls in each return guide, using grease to hold balls in place. Install return guides, clamp and screws. Rotate worm through its complete travel several times to insure balls are installed correctly and rotate freely.

2. Place upper bearing on worm shaft and slide worm shaft assembly into housing.

3. Place lower bearing in worm bearing adjuster and install bearing retainer with installer J-8564. Install adjuster assembly and lock nut on housing. Tighten adjuster only enough to hold worm bearings in place. Final adjustment will be made later.

4. Turn worm shaft until second and third teeth of ball nut line up with center tooth of pitman shaft. Assemble pitman shaft and lash adjuster with shim and install pitman shaft so that center tooth meshes with center groove in ball nut.

5. Place new gasket on side cover. Install side cover

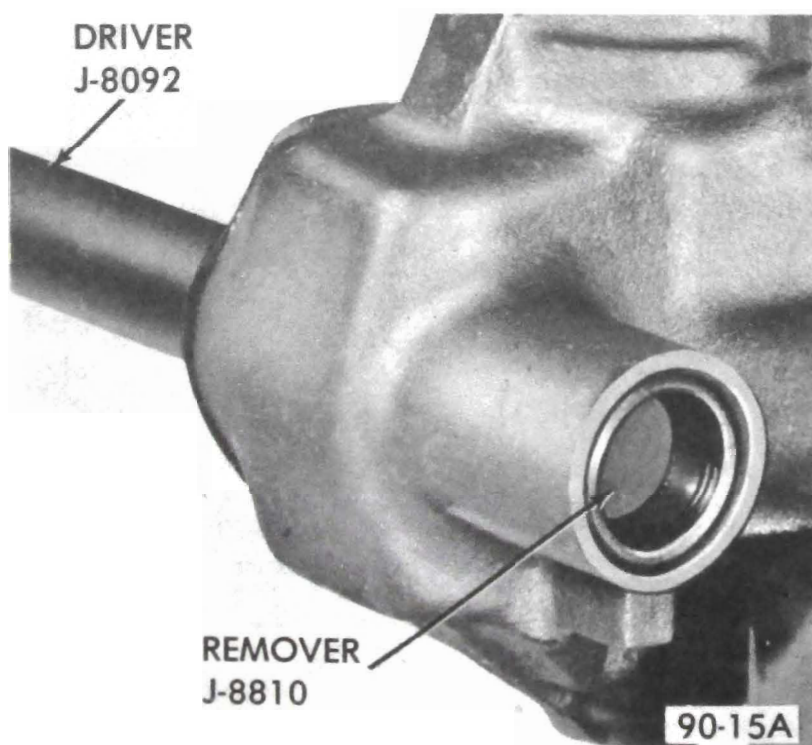

Figure 90-9 Installing Pitman Shaft Bushing

with gasket on lash adjuster by threading adjuster through cover.

6. Install side cover bolts. Torque bolts to specified value.

7. Turn lash adjuster so that teeth on shaft and ball nut engage smoothly but do not bind. Install lash adjuster lock nut loosely. Final adjustment will be made later.

8. To protect pitman shaft seal from damage, cover shaft splines with masking tape. Slide new seal into place and seat seal flush with surface of housing using Installer J-9540. See Figure 90-10.

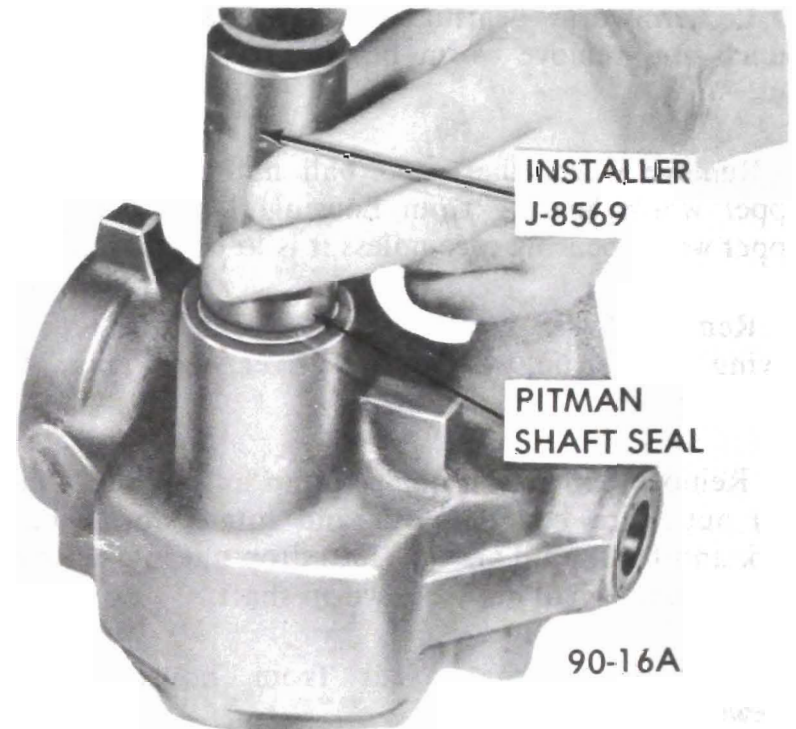

Figure 90-10 Installing Pitman Shaft Seal

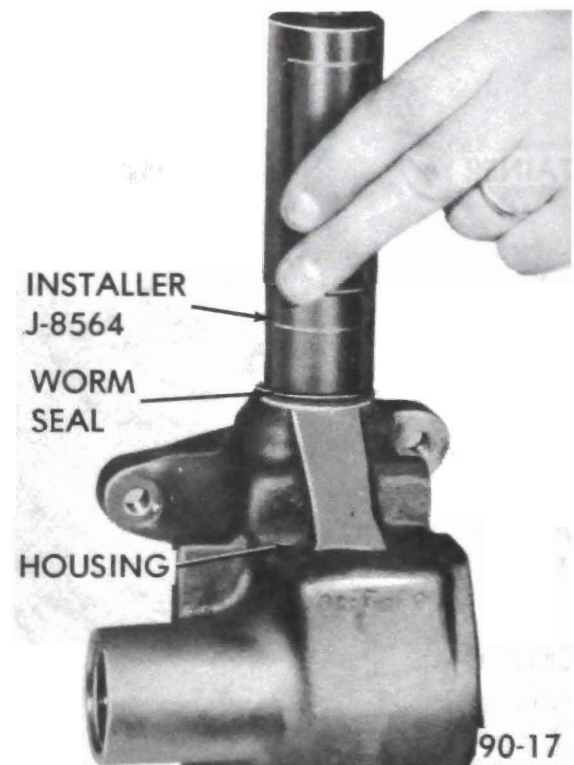
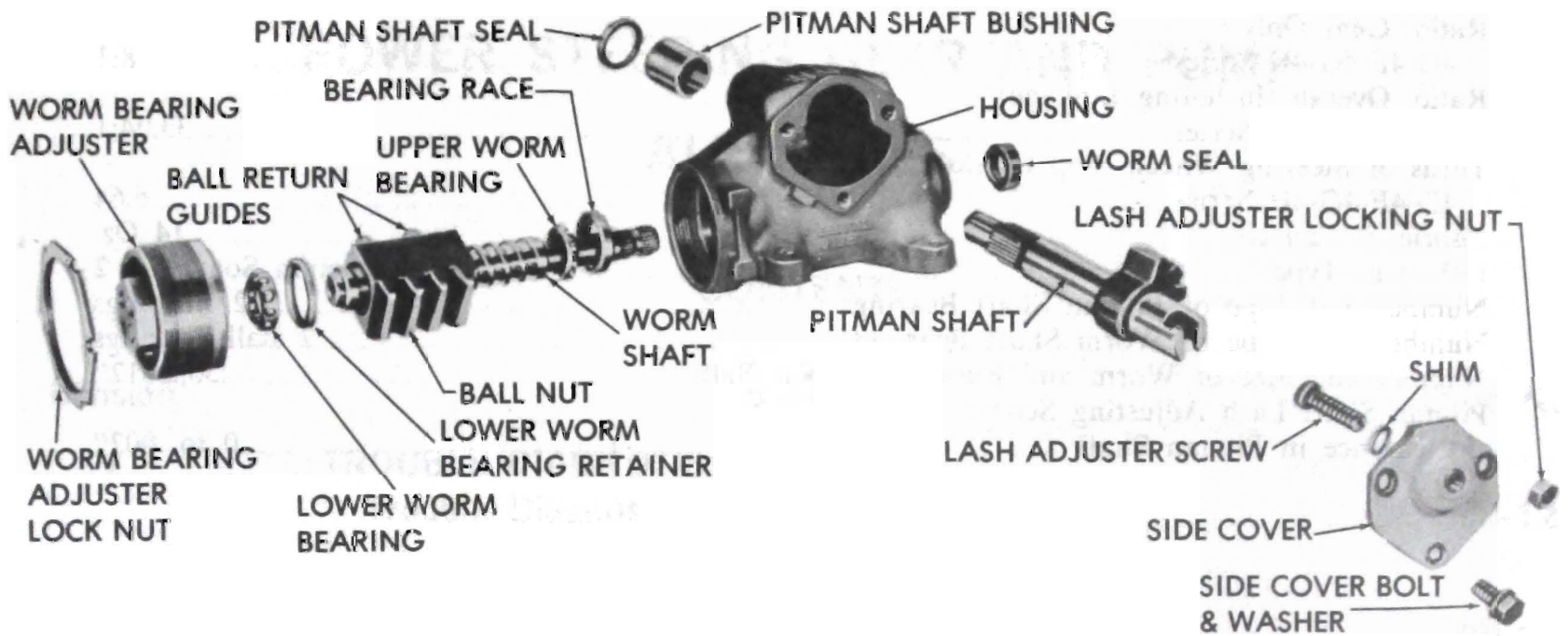

Figure 90-11 Installing Worm Shaft Seal

9. Install new worm shaft seal using Installer J-8564. Drive seal flush with surface of housing. See Figure 90-11.

10. Fill steering gear with Calcium Soap No. 2. Gear is now ready for final adjustment as described in paragraph 90-3.



90-18A

Figure 90-12 Manual Steering Gear - Exploded View

DIVISION VI

SPECIFICATIONS

90-6 MANUAL STEERING GEAR SPECIFICATIONS

A. Tightening Specifications

Use a reliable torque wrench to tighten the parts listed to insure proper tightness without straining or distorting parts. These specifications are for clean and lightly-lubricated threads only; dry or dirty threads produce increased friction which prevents accurate measurement of tightness.

Part	Location	Thread Size	Torque Lb.Ft.
Bolt	Gear Housing to Frame	7/16-14	70
Bolt	Lower Coupling Flange to Worm Shaft	3/8-24	30
Nut	Steering Column Coupling to Steering Gear Shaft Flange	5/16-24	20
Bolt	Gear Side Cover to Housing 4D-4F-4G-4H Series	3/8-16	35
Nut	Pitman Arm to Pinion Shaft	Special	180
Nut	Pitman Shaft Lash Adjuster Locking	7/16-20	23
Nut	Worm Bearing Adjuster Locking	Special	90
Screw	Ball Return Guide Retainer	1/4-28	10

B. Manual Steering Gear Specifications**Item Specification**

Gear Type	Recirculating Ball, Worm and Nut
Make	Saginaw
Ratio, Gear Only	
4D-4F-4G-4H Series	28:1
Ratio, Overall (Including Linkage)	
4D-4F-4G-4H Series	33.04:1
Turns of Steering Wheel, Stop to Stop	
4D-4F-4G-4H Series	6.64
Lubricant Capacity	14 Oz.
Lubricant Type	Calcium Soap No. 2
Number and Type of Pitman Shaft Bearings	2 Bushings
Number and Type of Worm Shaft Bearings	2 Ball Bearings
Number and Size of Worm and Rack-Piston Nut Balls	50,2812"
Pitman Shaft Lash Adjusting Screw	
Clearance in Pitman Shaft	0 to .002"