

# SECTION B

## EXHAUST SYSTEM

### ALL SERIES

#### CONTENTS

Division	Subject	Page No.
I	TRUBLE DIAGNOSIS: (Not Applicable)	
II	DESCRIPTION AND OPERATION: Description of Exhaust System .....	80-19
III	ADJUSTMENTS AND MINOR SERVICE: (Not Applicable)	
IV	REMOVAL AND INSTALLATION: Removal and Installation of Exhaust System .....	80-20
V	OVERHAUL AND MAJOR SERVICE: (Not Applicable)	
VI	SPECIFICATIONS: (Not Applicable)	

## DIVISION II

### DESCRIPTION AND OPERATION

#### 80-5 DESCRIPTION OF EXHAUST SYSTEM

The single exhaust system is standard equipment on all 4D-4F-4G-4H Series models except G. S. Series. On the G. S. models, dual exhaust systems are standard equipment. Single exhaust is standard on all 4L-4N-4R-4P-4U-4V Series cars. Dual exhaust systems are available as an option on LeSabre, Centurion, and Electras.

The 4D-4F-4G-4H-4L-4N Series (less the 455 cu.in. engine) exhaust systems do not have resonators. Sportwagons have a tail pipe which crosses over just behind the rear axle. In all wagons, the tail pipe exits just behind the left rear tire. This side exit reduces the possibility of having exhaust gas enter an open tail gate window.

All 4L-4N-4R-4P-4U-4V-4Y Series exhaust pipes, plus the 4D-4F-4G G. S. models, are of the double wall

laminated type. This double layer pipe is used to muffle pipe "ring" which is set-up by the firing impulses of the individual cylinders; the life of the pipe is also greatly increased.

For long life, all single exhaust system mufflers and tail pipes are aluminized. The 350 cubic inch four barrel hi-performance engines with dual exhaust systems have stainless steel inner shells, baffles, and end caps.

The single exhaust system mufflers and all rear exhaust pipes (both single and dual) on the 455 engines are aluminized for longer life; the dual exhaust system mufflers are constructed of stainless steel inner shells, baffles, and end caps. All resonators are constructed of stainless steel.

All exhaust pipe connections to exhaust manifold are of the ball joint type to allow angular movement for alignment purposes. On all single exhaust systems, the rear end of the front exhaust pipe (crossover) assembly is also of the ball joint type. All other connections are of the slip joint type. No gaskets are used in the entire system.

The muffler is of the oval-shaped dynamic flow type having very low back pressure. It is double wrapped of heavy gage aluminized and stainless steel with a layer of asbestos placed between wrappings to aid in reduction of noise transfer and to prevent any "oil-canning" effect. The exhaust system is supported by free-hanging rubber mountings which permit free movement of the system but do not permit transfer of noise and vibration into the passenger compartment.

The routing of the rear exhaust pipe, between the muffler and resonator, for 1971-72 Estate Wagons is different than in 1970. The pipe is routed underneath the axle tube. Extreme care should be taken when lifting the Estate Wagon on an axle lift hoist to make sure the pipe is not pinched or damaged. The resonator and rear exhaust pipe are serviced as a single unit if the resonator is damaged. If, for some reason, the pipe is damaged but not the resonator, the pipe may be cut off and a new slip joint type pipe used as a replacement.

## DIVISION IV

### REMOVAL AND INSTALLATION

#### 80-6 REMOVAL AND INSTALLATION OF EXHAUST SYSTEM PARTS

Sealer #1051249 (Group 8.800), or equivalent, to be applied to all slip joints before assembly.

##### A. Removal and Installation of Muffler

Check complete exhaust system and nearby body areas and trunk lid for broken, damaged, missing or mispositioned parts, open seams, holes, loose connections, or other deterioration which could permit exhaust fumes to seep into the trunk or passenger compartment. Any defects should be corrected immediately. To help insure continued integrity, exhaust system pipes and resonators rearward of the muffler must be replaced whenever a new muffler is installed.

The following instructions apply, in general, to all exhaust systems. For specific information, see the illustrations following this paragraph.

1. Remove U-bolts and clamps from muffler inlet and outlet nipples.
2. Split muffler inlet nipple on opposite sides so that it is loose on inner pipe. Be careful not to damage inner pipe.
3. Disconnect front or intermediate exhaust pipe at forward end ball joint by removing bolts or nuts.

4. Pull exhaust pipe forward and twist to disengage from muffler. Lay exhaust pipe on floor.
5. Remove old muffler by pulling forward and twisting.
6. Subassemble exhaust pipe and new muffler on floor, tightening new U-bolt and nuts just snug so that muffler will move but will stay where moved.
7. Raise exhaust pipe-muffler subassembly into position and install new bolts or nuts at forward ball joint just snug.
8. Install new U-bolt and nuts at rear of muffler just snug.
9. Align muffler and exhaust pipe. See illustration that applies--Figures 80-17 through 80-23.
10. Tighten all bolts and nuts.

##### B. Removal and Installation of Resonator

1. Remove tail pipe clamp bolt and spread clamp so that resonator-tail pipe assembly will slide through clamp.
2. Split resonator inlet nipple on opposite sides so that it is loose on rear exhaust pipe. Be careful not to damage exhaust pipe.
3. Slide old resonator to rear and then forward out of tail pipe clamp.
4. Install new hanger where necessary.
5. Install new resonator-tail pipe assembly.
6. Install new U-bolt and clamp. Install new tail pipe hanger bolt. Tighten all nuts so that resonator can be moved but will stay where moved.
7. Align resonator assembly. See illustration that applies--Figures 80-17 through 80-23.
8. Tighten all clamps.

##### C. Removal and Installation of Front or Intermediate Exhaust Pipe

1. Cut off defective exhaust pipe just forward of muffler nipple.
2. Remove U-bolt and clamp from forward muffler nipple. Disconnect exhaust pipe at forward end ball joint by removing bolts or nuts.
3. Split stub end of exhaust pipe in muffler, being careful not to damage muffler nipple. Collapse stub end and remove.

4. Raise new exhaust pipe into position and install new bolts or nuts at forward ball joint just snug.
5. Install new U-bolt and clamp just snug.
6. Align exhaust pipe. See illustration that applies - Figures 80-17 through 80-23.
7. Tighten all bolts and nuts.

#### **D. Removal and Installation of Tail Pipe**

1. Raise car so that rear axle and frame are separated as far as possible.
2. Cut off defective tail pipe just rearward of muffler nipple.

3. Remove tail pipe clamp bolt and spread clamp. Remove oil tail pipe.
4. Split stub end of tail pipe in muffler, being careful not to damage muffler nipple. Collapse stub end and remove.
5. Position new tail pipe over rear axle and into position.
6. Install new U-bolt and clamp. Install new tail pipe hanger clamp bolt. Tighten all nuts just snug.
7. Align tail pipe. See Figures 80-17 through 80-23.
8. Tighten all nuts.

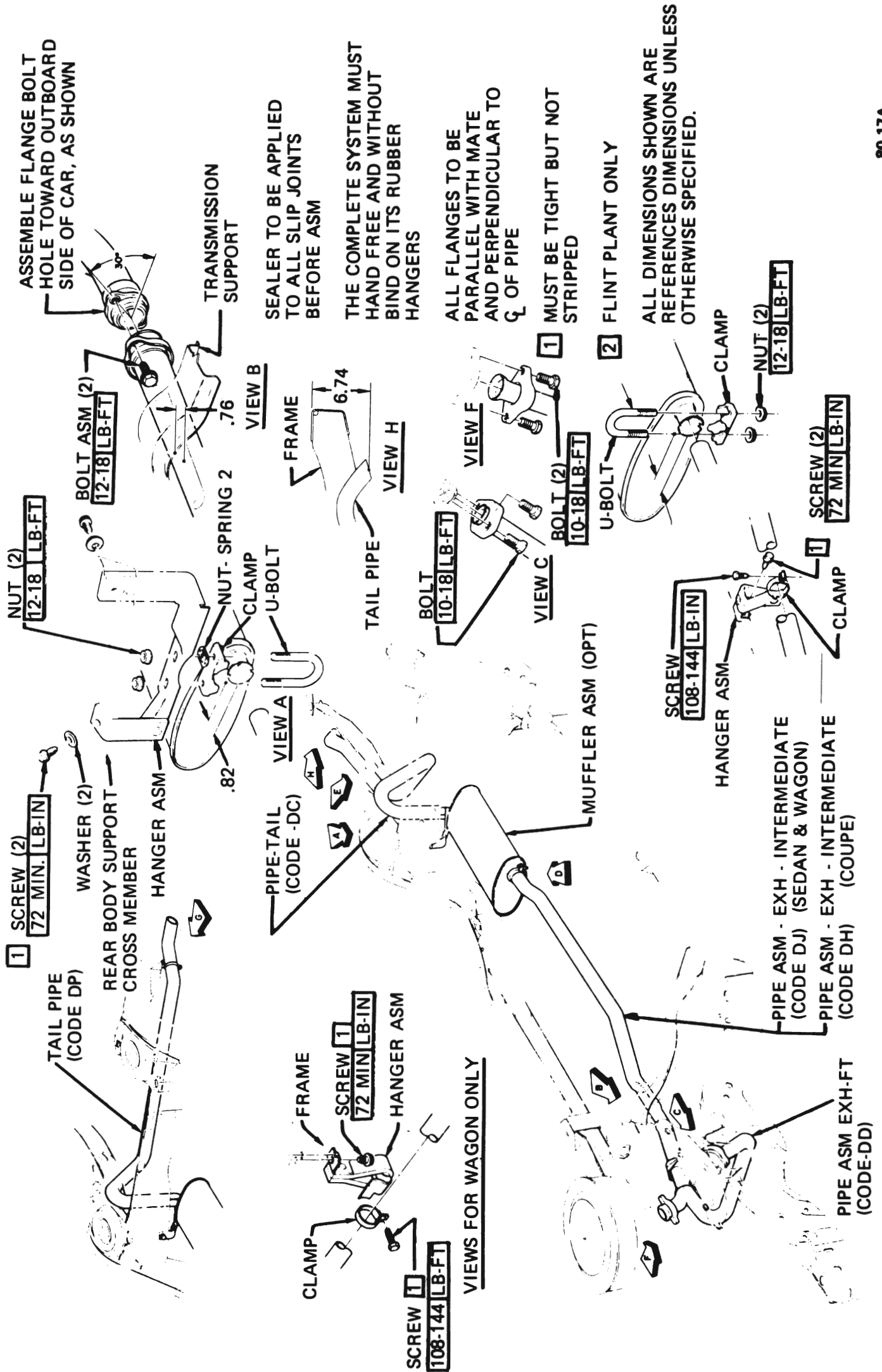

Figure 80-17 Exhaust System V-8 Skylark, Skylark Custom, and Sport Wagon Except G. S.

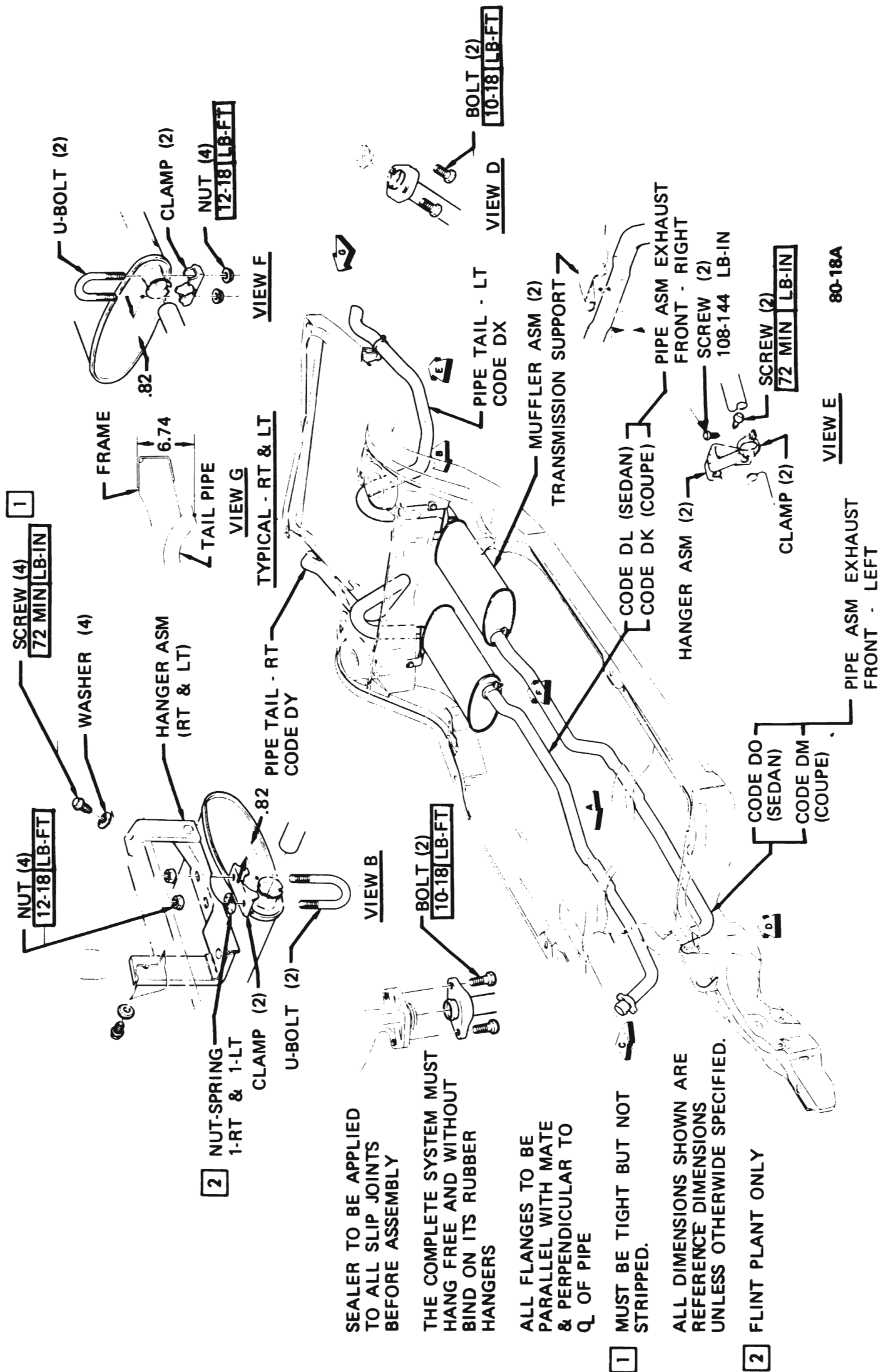
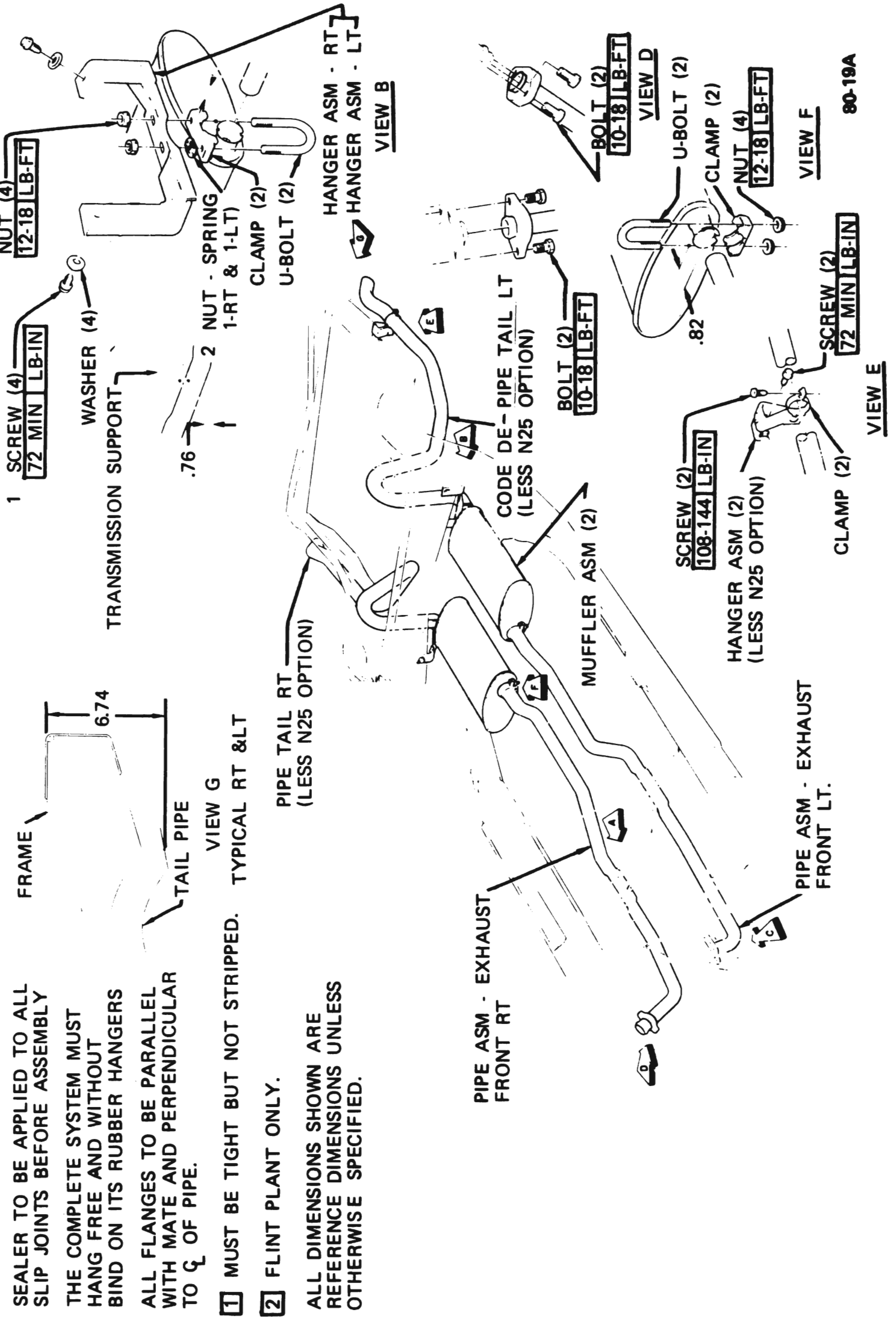

Figure 80-18 Exhaust System 350 4 BBL. - High Performance - Dual Exhaust System



SEALER TO BE APPLIED TO ALL SLIP JOINTS BEFORE ASSEMBLY

THE COMPLETE SYSTEM MUST HANG FREE AND WITHOUT BIND ON ITS RUBBER HANGERS

ALL FLANGES TO BE PARALLEL WITH MATE AND PERPENDICULAR TO  $\phi$  OF PIPE.

- 1 MUST BE TIGHT BUT NOT STRIPPED.
- 2 FLINT PLANT ONLY.

ALL DIMENSIONS SHOWN ARE REFERENCE DIMENSIONS UNLESS OTHERWISE SPECIFIED.

Figure 80-19 G. S. Series - Dual Exhaust - Less N-25 Option

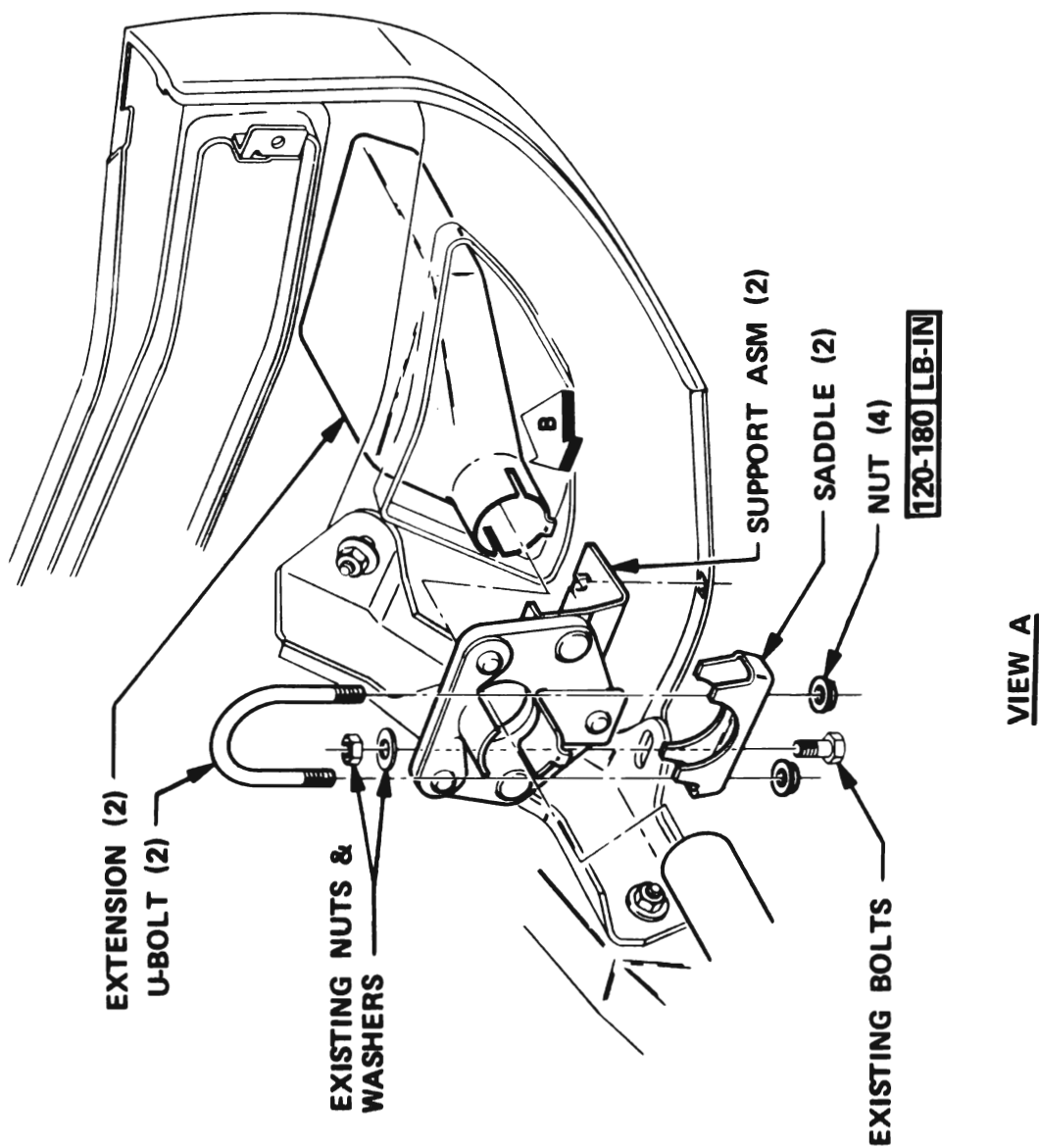
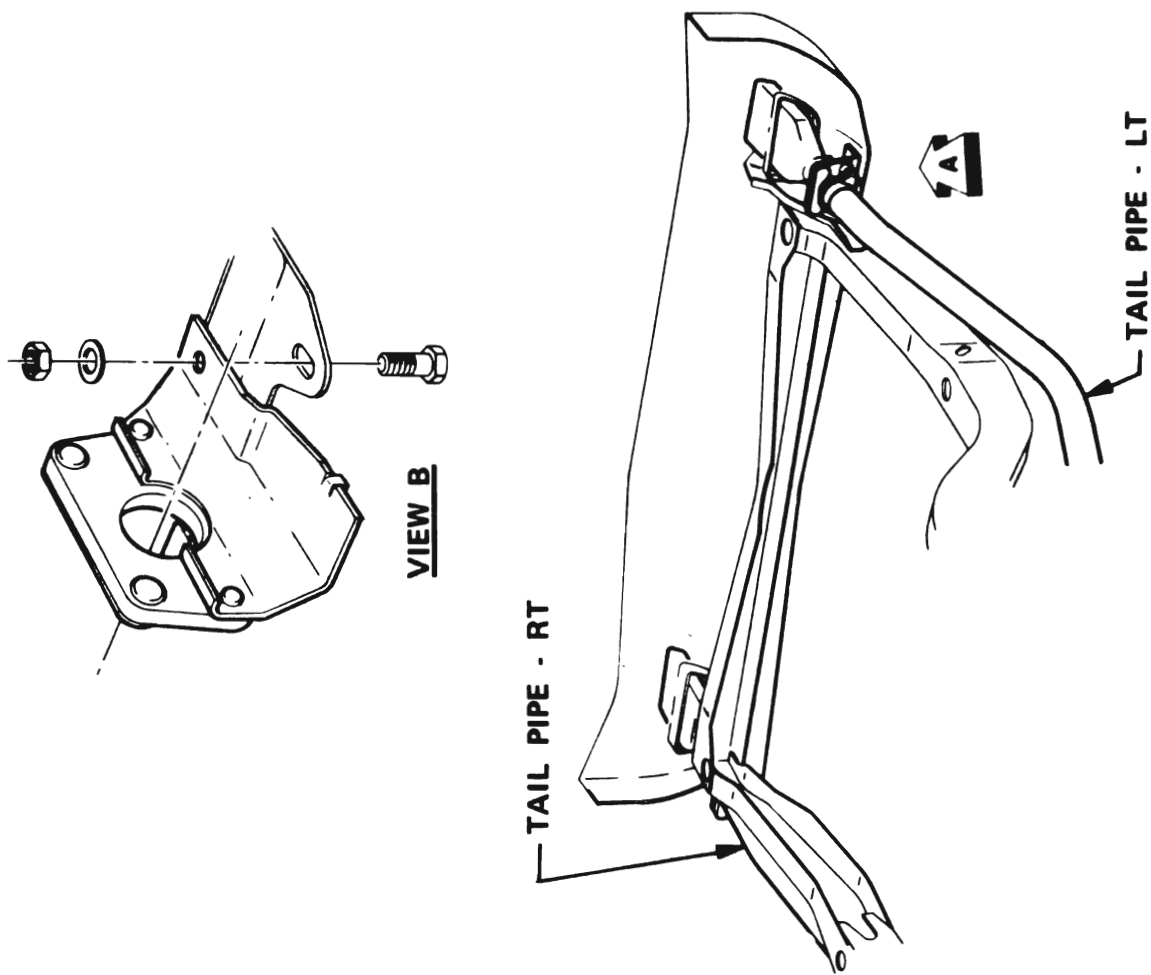

80-20A

Figure 80-20 G.S. Dual Exhaust System - N-25 Option

SEALER TO BE APPLIED TO ALL SLIP JOINTS BEFORE ASSEMBLY.

THE COMPLETE SYSTEM MUST HANG FREE & WITHOUT BIND ON ITS RUBBER HANGERS.

ALL FLANGES TO BE PARALLEL WITH MATE & PERPENDICULAR TO CL OF PIPE.

1 RESONATOR NOT USED ON 52-54 SINGLE 350 ENGINE

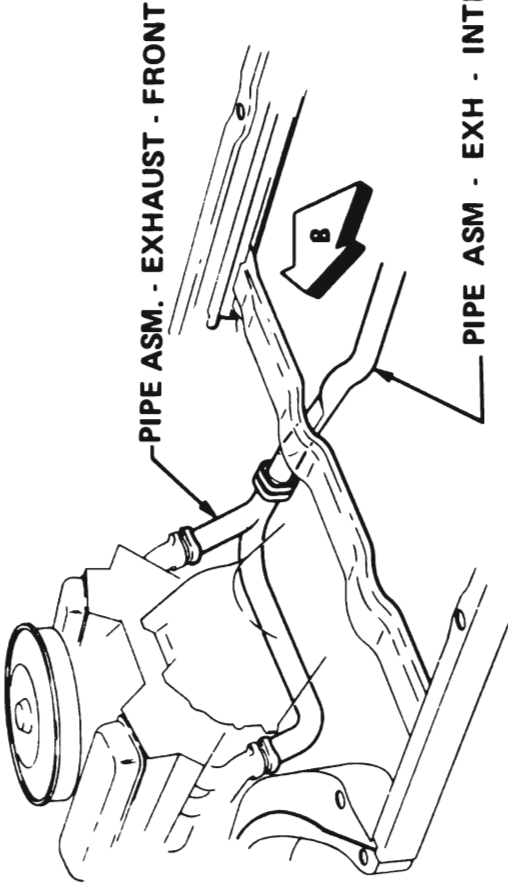

SINGLE SYSTEM

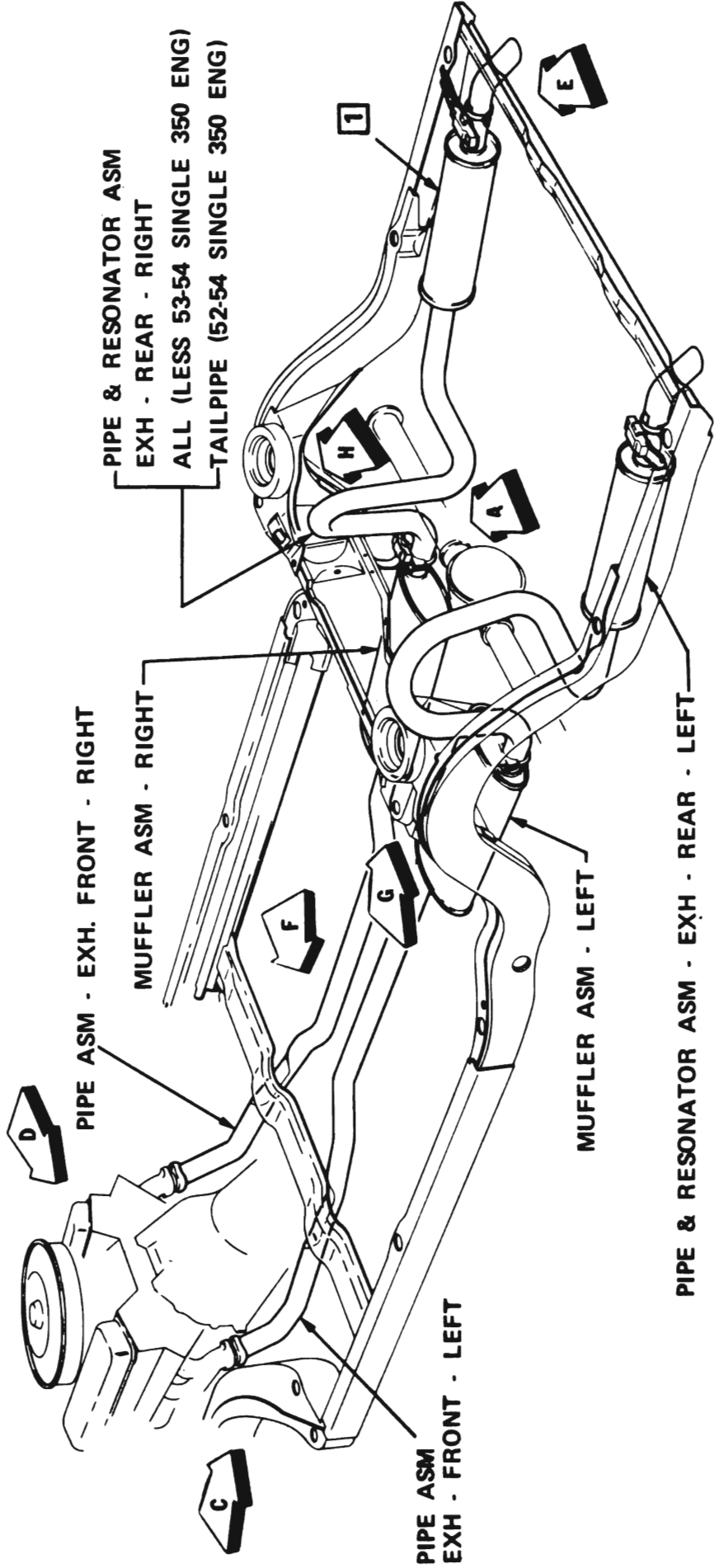

DUAL SYSTEM

Figure 80-21 Exhaust Systems (Single and Dual) - LeSabre, Centurion, Electra, and Riviera



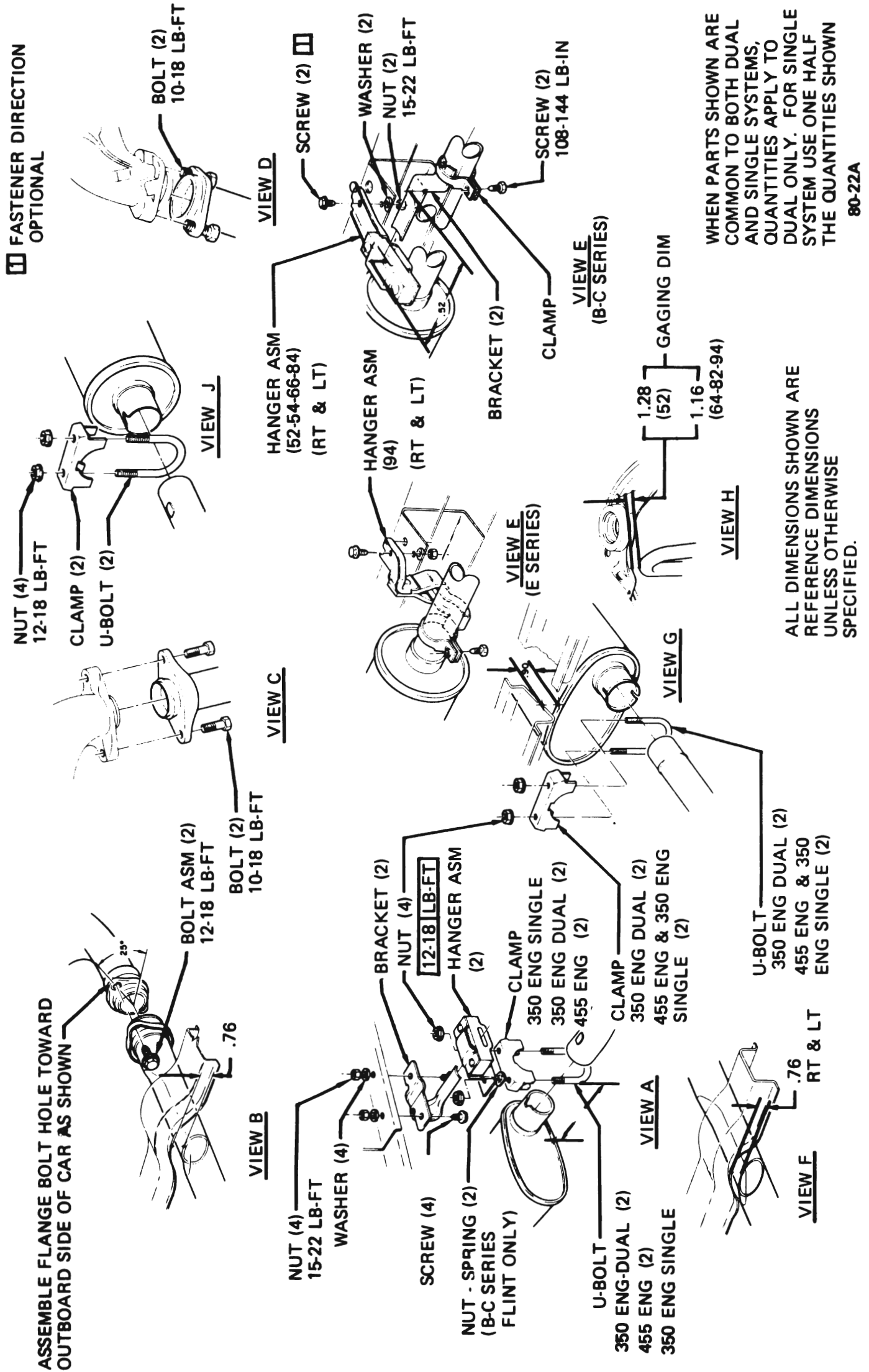

Figure 80-22 Assembly Information for Figure 80-21

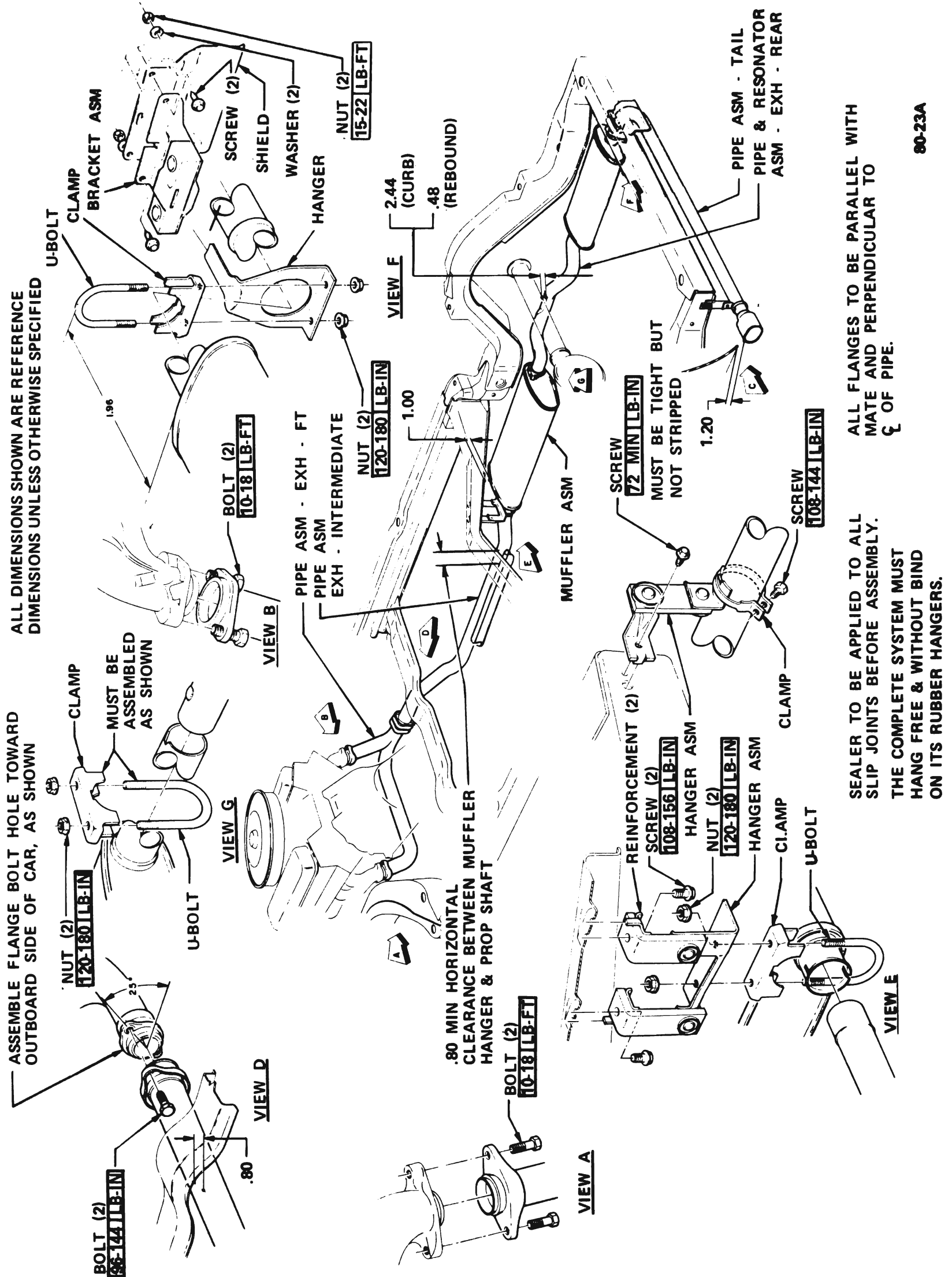

Figure 80-23 Single Exhaust System - Estate Wagon