

**SECTION A**

**TURBO HYDRA-MATIC 350-375B AUTOMATIC  
TRANSMISSION  
4D-4F-4G-4H-4L-4N SERIES**

**CONTENTS**

<b>Division</b>	<b>Subject</b>	<b>Page No.</b>
<b>I</b>	<b>TROUBLE DIAGNOSIS:</b>	
	Sequence for Turbo Hydra-Matic 350-375B Transmission Diagnosis .....	<b>75-3</b>
	Turbo Hydra-Matic 350-375B Transmission Oil Checking Procedures .....	<b>75-4</b>
	External Oil Leaks .....	<b>75-4</b>
	Vacuum Modulator Diagnosis Procedure .....	<b>75-5</b>
	Turbo Hydra-Matic 350-375B Trouble Diagnosis Chart .....	<b>75-7</b>
	Hydraulic Pressure Checks .....	<b>75-12</b>
<b>II</b>	<b>DESCRIPTION AND OPERATION:</b>	
	Description of Turbo Hydra-Matic 350-375B Automatic Transmission .....	<b>75-19</b>
	Functions of Valves and Hydraulic Control Units .....	<b>75-20</b>
	Mechanical Operation .....	<b>75-24</b>
	Hydraulics System .....	<b>75-32</b>
<b>III</b>	<b>ADJUSTMENTS AND MINOR SERVICE:</b>	
	Detent Cable Adjustment .....	<b>75-49</b>
	Removal of Propeller Shaft Yoke Seal, Speedometer Drive Gear and Governor .....	<b>75-49</b>
	Removal of Oil Pan, Oil Strainer and Valve Body .....	<b>75-51</b>
<b>IV</b>	<b>REMOVAL AND INSTALLATION:</b>	
	Transmission Assembly Removal and Installation .....	<b>75-53</b>
<b>V</b>	<b>OVERHAUL AND MAJOR SERVICE:</b>	
	Preliminary Instructions .....	<b>75-57</b>
	Removal of Converter, Holding Tool, Converter and Vacuum Modulator .....	<b>75-57</b>
	Removal of Extension Housing, Lip Seal	

and Bushing .....	75-57
Installing Extension Housing Bushing and Lip Seal .....	75-59
Removal of Oil Pump Screen, Governor Screen and Check Balls .....	75-60
Removal of Manual Shaft, Inner Lever, Parking Pawl and Intermediate Servo Piston .....	75-60
Removal of Pump Assembly, Cushion Spring, Inter- mediate Clutch Plates and Overrun Brake Band .....	75-62
Removal of Direct and Forward Clutch Assemblies, Input Ring Gear and Output Carrier .....	75-64
Removal of Sungear Shell, Low and Reverse Clutch Support Assembly, Low and Reverse Clutch Plates and Reaction Carrier .....	75-66
Removal of Output Ring Gear and Shaft Assembly, and Output Ring Gear to Case Needle Bearing Assembly .....	75-68
Removal of Low and Reverse Clutch Piston and Case Bushings .....	75-69
Removal and Installation of Intermediate Clutch Accumulator .....	75-71
Disassembly and Reassembly of Oil Pump Assembly .....	75-72
Disassembly and Reassembly of Direct Clutch .....	75-77
Disassembly and Reassembly of Forward Clutch Assembly .....	75-81
Disassembly and Reassembly of Sungear to Drive Shell .....	75-85
Disassembly and Reassembly of Low and Reverse Roller Clutch Assembly .....	75-86
Valve Body Disassembly Inspection and Reassembly .....	75-89
Assembly of Transmission from Major Parts and Units .....	75-90
Converter Checking Procedure .....	75-105
Installation of Governor Bushing .....	75-106

**VI****SPECIFICATIONS:**

General Specifications .....	75-112
------------------------------	--------

**DIVISION I****TROUBLE DIAGNOSIS****75-1 SEQUENCE FOR TURBO HYDRA-MATIC 350-375B TRANSMISSION DIAGNOSIS**

1. Check and correct oil level. Refer to Paragraph 75-36, Subparagraph "E" for checking for refill procedures.
2. Check detent cable adjustment. See Figure 75-53.
3. Check and correct vacuum line and fittings.

4. Check and correct manual linkage. See Group 73.
5. Road test car.
  - a. Install oil pressure gage.
  - b. Road test using all selective ranges, noting when discrepancies in operation or oil pressure occur.
  - c. Attempt to isolate the unit or circuit involved in the malfunction.
  - d. If engine performances indicates an engine tune- up is required, this should be performed before road testing is completed or transmission correction attempted. Poor engine performance can result in rough shifting or other malfunctions.

### 75-2 TURBO HYDRA-MATIC 350-375B TRANSMISSION CHECKING PROCEDURES

Before diagnosis of any transmission complaint is attempted, there must be understanding of oil checking procedure and what appearance the oil should have. Many times a transmission malfunction can be traced to low oil level, improper reading of dipstick, or oil appearance; therefore, a careful analysis of the condition of oil and the level may eliminate needless repairs.

When checking oil level in the Turbo Hydra-Matic 350- 375B Transmission, the procedure outlined in Paragraph 75-36, Subparagraph "D" should be followed to obtain the most accurate reading.

Also when the dipstick is removed, it should be noted whether the oil is devoid of air bubbles or not. Oil with air bubbles gives an indication of an air leak in the suction lines, which can cause erratic operation and slippage. Water in the oil imparts a milky, pink cast to the oil and can cause spewing.

### 75-3 EXTERNAL OIL LEAKS

#### A. Determining Source of Oil Leak

Before attempting to correct an oil leak, the actual source of the leak must be determined. In many cases, the source of the leak can be deceiving due to "wind flow" around the engine and transmission.

The suspected area should be wiped clean of all oil before inspecting for the source of the leak. Red dye is used in the transmission oil at the assembly plant and will indicate if the oil leak is from the transmission.

The use of a "Black Light" to locate the point at which the oil is leaking is helpful. Comparing the oil from the leak to that on the engine or transmission dipstick, when viewed by black light, will determine the source of the leak - engine or transmission.

Oil leaks around the engine and transmission are generally carried toward the rear of the car by air stream. For example, a transmission oil filler tube to case leak will sometimes appear as a leak at the rear of the transmission. In determining the source of a leak, proceed as follows:

1. Degrease underside of transmission.
2. Road test to get unit at operating temperature.
3. Inspect for leak with engine running.
4. With engine off, check for oil leaks due to the raised oil level caused by drain back.

#### B. Possible Points of Oil Leaks

1. Transmission Oil Pan Leak.
  - a. Attaching bolts not correctly torqued.
  - b. Improperly installed or damaged pan gasket.
  - c. Oil pan gasket mounting face not flat.
2. Extension Housing.
  - a. Attaching bolts not correctly torqued.
  - b. Rear seal assembly damaged or improperly installed.
  - c. Square seal, extension to case, damaged or improperly installed.
  - d. Porous casting. See subparagraph C.
3. Case Leak.
  - a. Filler pipe "O" ring seal damaged or missing; misposition of filler pipe bracket to engine.
  - b. Modulator assembly "O" ring seal damaged or improperly installed.
  - c. Detent cable connector "O" ring seal damaged or improperly installed.
  - d. Governor cover not tight, gasket damaged or leak between case face and gasket.
  - e. Speedometer gear "O" ring damaged.
  - f. Manual shaft seal damaged or improperly installed.
  - g. Line pressure tap plug loose.
  - h. Vent pipe (refer to item 5).
  - i. Porous casting. See Subparagraph C.
4. Leak at Front of Transmission.

a. Front pump seal leaks.

(1) Seal lip cut. Check converter hub, etc.

(2) Bushing moved and damaged. Oil return hole plugged.

(3) No oil return hole.

b. Front pump attaching bolts loose or bolt washer type seals damaged or missing.

c. Front pump housing "O" ring damaged or cut.

d. Converter leak in weld area.

e. Porous casting (pump).

5. Oil Comes Out Vent Pipe.

a. Transmission over-filled.

b. Water in oil.

c. Foreign material between pump and case or between pump cover and body.

d. Case - porous near converter bosses. Front pump cover or housing oil channels shy or stock near breather. See Subparagraph C.

e. Pump to case gasket mis-positioned.

### C. Case Porosity Repair

Turbo Hydra-Matic 350-375B transmission external oil leaks caused by case porosity can be successfully repaired with the transmission in the car by using the following recommended procedures:

1. Road test and bring the transmission to operating temperature, approximately 180 degrees F.

2. Raise car on a hoist or jack stand, engine running, and locate source of oil leak. Check for oil leaks in Low, Drive, and Reverse.

3. Shut engine off and thoroughly clean area to be repaired with a suitable cleaning solvent and a brush - air dry.

A clean, dry soldering acid brush can be used to clean the area and also to apply the epoxy cement.

4. Using instructions of the manufacturer, mix a sufficient amount of epoxy to make the repair. Make certain the area to be repaired is fully covered.

6. Allow cement to cure for 3 hours before starting engine.

7. Road test and check for leaks.

### 75-4 VACUUM MODULATOR DIAGNOSIS PROCEDURE

A defective vacuum modulator can cause one or more of the following complaints.

1. Harsh upshifts and downshifts.

2. Delayed upshifts.

3. Soft upshifts and downshifts.

4. Slips in low, drive and reverse.

5. Transmission overheating.

6. Engine burning transmission oil.

If any one of the above complaints are encountered, the modulator must be checked.

The vacuum modulator, See Figure 75-1, has three areas to be checked. If any one of the three (3) areas fail to pass the prescribed checks, the modulator must be replaced.

1. Bellows Comparison Check.

Using a comparison gage, furnished with Dealer Service Information Bulletin 67-I-37, compare the load of a known good modulator *of the same part number* with the modulator in question. Refer to modulator usage chart in Paragraph 75-36, Subparagraph A.

To check bellows load proceed as follows:

a. Insert one end of the comparison gage into the suspected defective modulator sleeve. Insert the opposite end of the gage into a known, good modulator *of the same part number* as the suspected defective modulator. Refer to modulator usage chart in Paragraph 75-36, Subparagraph A. The part number of the modulator assembly is located on the back side of the modulator.

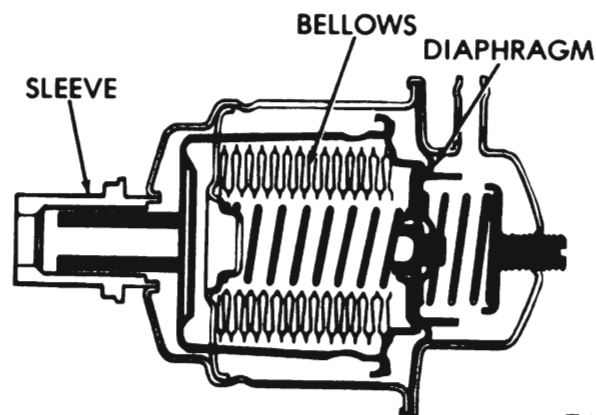

74-419

Figure 75-1 - Vacuum Modulator Assembly



b. Holding the modulators in a horizontal position, see Figure 75-2, bring them slowly together under pressure. The modulator bellows in question, if defective, will reach the center line of the comparison gage before the known good modulator lines up with the outer gage line. See Figure 75-3.

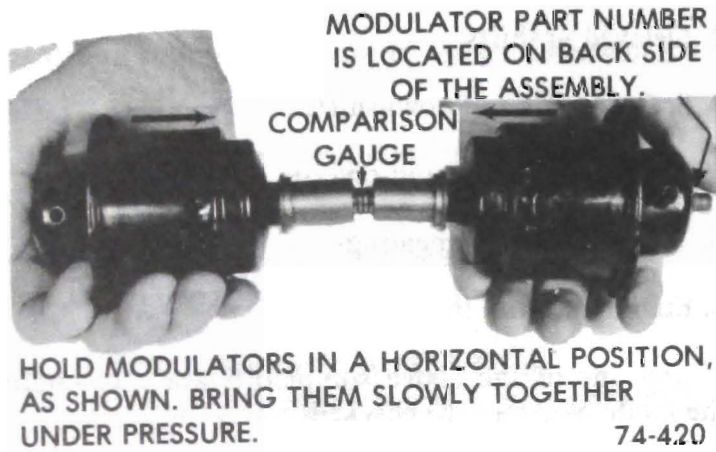

Figure 75-2 - Holding Modulator in Horizontal Position

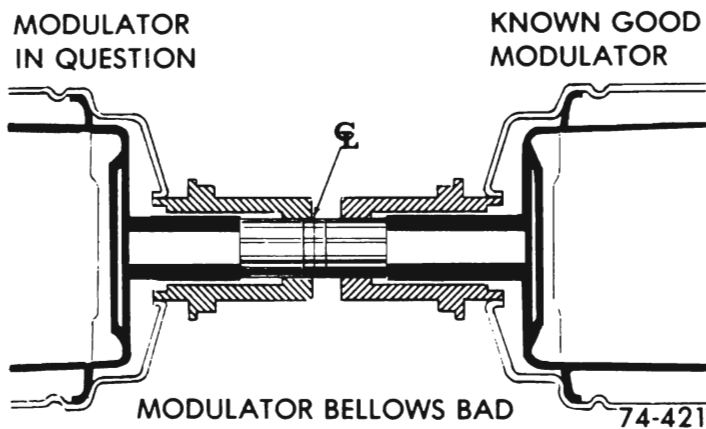

Figure 75-3 - Modulator Bellows - (Bad)

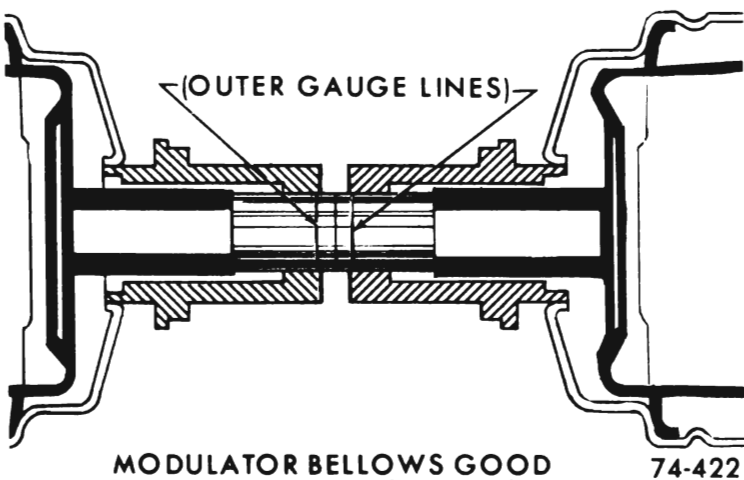

Figure 75-4 - Modulator Bellows - (Good)

If the modulator bellows in question is good, both modulator assemblies will be within the outer gage lines as the assemblies are slowly brought together. See Figure 75-4.

2. Vacuum Diaphragm Leak Check.

Turn modulator so vacuum line stem points downward. If transmission oil comes out the vacuum diaphragm is defective.

Gasoline and/or water vapor may settle in the vacuum side of the modulator. If this is found WITHOUT the presence of oil, the modulator MUST NOT BE CHANGED.

Check solution that comes out of the modulator for evidence of lubricity. If the solution does not have the feel of oiliness it can be assumed the solution is a mixture of gas and/or water. The only way transmission oil can be on the vacuum side of the modulator is by a leak in the vacuum diaphragm.

If oil is found, the modulator must be replaced. If oil is not found in the vacuum side of the modulator but the transmission oil level is continually low, and *no external leaks are found*, there is a possibility that a pin hole leak exists in the diaphragm and the modulator should be replaced.

3. Inspection for External Damage.

a. Check for dents or cracks in modulator.

b. Check modulator valve sleeve alignment. Roll modulator on a flat surface to determine if the sleeve is concentric to the modulator can. See Figure 75- 5. If the sleeve is bent, runout will be visible, and modulator must be replaced.

If the modulator passes the above checks, the following

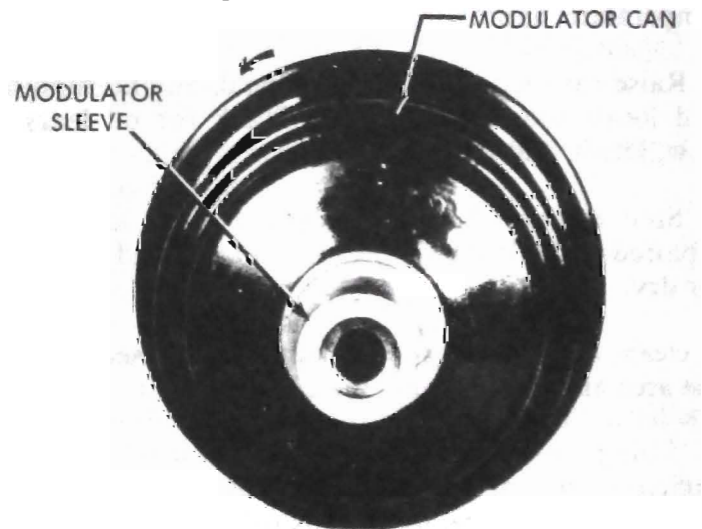

ROLL MODULATOR ON FLAT SURFACE TO DETERMINE IF THE SLEEVE IS CONCENTRIC TO THE MODULATOR CAN. IF THE SLEEVE IS BENT, RUNOUT WILL BE VISIBLE  
74-423

Figure 75-5 - Checking Modulator Sleeve Alignment

items should also be checked as a possible cause of the problem.

1. Check freeness of modulator valve in modulator.
2. Check freeness of modulator valve in transmission case.

3. Check the vacuum line from the manifold to modulator for holes, cracks or dents. Check the rubber hose connections at the modulator and at the intake manifold for leaks.

### 75-5 TURBO HYDRA-MATIC 350-375B TROUBLE DIAGNOSIS CHART

Condition	Possible Cause	Correction	
No drive in drive range - (install pressure gauge).	1. Low oil level.	1. Correct level - check for external leaks or defective vacuum modulator (leaking diaphragm will evacuate oil from unit).	
	2. Manual linkage adjustment.	2. See Section 73.	
	3. Low oil pressure.	3a. Filter assembly - "O" ring missing or damaged, strainer blocked.	
		b. Pump assembly - pressure regulator, pump drive gear - tangs damaged by converter.	
		c. Case - porosity in intake bore.	
	4. Control valve assembly.	4. Manual valve disconnected from inner lever.	
5. Forward clutch.	5a. Forward clutch does not apply - piston cracked; seals missing, damaged; clutch plates burned.		
	b. Pump feed circuit to forward clutch oil seal rings missing or broken on pump cover; leak in feed circuits; pump to case gasket mispositioned or damaged. Clutch drum ball check stuck or missing.		
6. Roller clutch assembly.	6. Broken spring or damaged cage.		
Oil pressure high or low - (see oil pressure check, paragraph 75-6).	1. High oil pressure.	1a. Vacuum line or fittings leaking.	
		b. Vacuum modulator.	
		c. Modulator valve.	
		d. Pressure regulator.	
		e. Oil pump.	
	2. Low oil pressure.	2a. Vacuum line or fittings obstructed.	
		b. Vacuum modulator.	
		c. Modulator valve.	
		d. Pressure regulator.	
		e. Governor	
		f. Oil pump.	

**75-8 1972 BUICK SERVICE MANUAL**

1-2 shift - full throttle only.	1. Detent valve.	1. Sticking or linkage misadjusted (see Figure 75-53).
	2. Vacuum leak.	2. Vacuum line or fittings leaking.
	3. Control valve assembly.	3a. Valve body gaskets - leaking, damaged, incorrectly installed. b. Detent valve train stuck. c. 1-2 valve stuck.
	4. Case assembly.	4. Porosity
First speed only - no 1-2 shift.	1. Governor assembly.	1a. Governor valve sticking. b. Driven gear loose, damaged or worn (check for pin in case and length of pin showing); also, check output shaft drive gear for nicks or rough finish, if driven gear shows damage.
	2. Control valve assembly.	2a. 1-2 shift valve train stuck closed. b. Governor feed channels blocked. c. Valve body gaskets - leaking, damaged, incorrectly installed.
	3. Case	3a. Porosity between channels. b. Governor feed channel blocked, governor bore scored or worn, allowing cross pressure leak.
	4. Intermediate clutch.	4a. Clutch piston seals - missing, improperly assembled, cut. b. Intermediate roller clutch. Broken spring or damaged cage.
First and second speeds only, no 2-3 shift.	1. Control valve assembly.	1a. 2-3 shift train stuck. b. Valve body gaskets - leaking, damaged, incorrectly installed.
	2. Direct clutch.	2a. Pump hub - direct clutch oil seal rings - broken, missing. b. Clutch piston seals - missing, improperly assembled, cut, piston ball check stuck or missing.
Drive in "Neutral".	1. Manual linkage.	1. Misadjusted
	2. Forward clutch.	2. Clutch does not release - (this condition will also cause "No Reverse").
No motion in "Reverse", or slips in "Reverse" - (install pressure gauge).	1. Low oil level.	1. Add oil - see paragraph 75-36, subparagraph E.
	2. Manual linkage.	2. Misadjusted. Refer to Group 73.

	<p>3. Oil pressure. Refer to paragraph 75-6.</p>	<p>3a. Modulator valve stuck.</p> <p>b. Modulator and reverse boost valve stuck.</p> <p>c. Pump hub - direct clutch oil seal rings broken, missing.</p> <p>d. Direct clutch piston seal cut or missing.</p> <p>e. Low and reverse clutch piston seal cut or missing.</p> <p>f. No. 1 check ball missing.</p>
	<p>4. Control valve assembly.</p>	<p>4a. Valve body gaskets - leaking, damaged, incorrectly installed (other malfunctions may also be indicated).</p> <p>b. 2-3 valve train stuck in upshifted position. This will also cause 1-3 upshift in drive range.</p> <p>c. 1-2 valve train stuck in upshifted position.</p>
	<p>5. Intermediate servo.</p>	<p>5a. Piston or pin stuck so intermediate overrun band is applied.</p>
	<p>6. Low and reverse clutch.</p>	<p>6. Piston out or seal damaged or missing.</p>
	<p>7. Direct clutch.</p>	<p>7a. Outer seal damaged or missing.</p> <p>b. Clutch plates burned - may be caused by stuck ball check in piston.</p>
	<p>8. Forward clutch.</p>	<p>8. Clutch does not release (will also cause "Drive" in "Neutral").</p>
<p>Slips in all ranges, slips on start - (install pressure gauge).</p>	<p>1. Oil level low.</p> <hr/> <p>2. Oil pressure. Refer to paragraph 75-6.</p> <hr/> <p>3. Oil pressure. Refer to paragraph 75-6.</p> <hr/> <p>4. Case</p> <hr/> <p>5. Forward clutch slipping.</p>	<p>1. Add oil - see paragraph 75-36, subparagraph E.</p> <hr/> <p>2a. Vacuum modulator defective.</p> <p>b. Vacuum modulator valve sticking.</p> <p>c. Filter assembly - plugged or leaks; grommet "O" ring missing or damaged.</p> <hr/> <p>3a. Pressure regulator valve stuck.</p> <p>b. Pump to case gasket damaged or incorrectly installed.</p> <hr/> <p>4. Cross leaks, porosity.</p> <hr/> <p>5a. If burned, look for cause.</p> <p>b. Oil seal rings on pump cover broken or worn.</p>
<p>Slips 1-2 shift - (install pressure gauge).</p>	<p>1. Oil level low.</p>	<p>1. Add oil - see paragraph 75-36, subparagraph E.</p>

	2. Oil pressure. Refer to paragraph 75-6.	2a. Vacuum modulator assembly defective. b. Modulator valve sticking. c. Pump pressure regulator valve.
	3. 2-3 accumulator.	3. Oil ring damaged or missing.
	4. 1-2 accumulator.	4. Oil ring missing or damaged, case bore damaged.
	5. Pump to case gasket.	5. Mispositioned
	6. Case	6. Porosity between channels.
	7. Intermediate clutch.	7. Piston seals missing or damaged; clutch plates burned.
Rough 1-2 shift - (install pressure gauge).	1. Oil pressure. Refer to paragraph 75-6.	1a. Vacuum modulator - check for loose fittings, restrictions in line, modulator assembly defective. b. Modulator valve stuck. c. Valve body - regulator or boost valve stuck. d. Pump to case gasket - off location or damaged.
	2. Case	2. Porosity between channels.
	3. 1-2 accumulator assembly.	3a. Oil rings damaged. b. Piston stuck. c. Broken or missing spring. d. Bore damaged.
Slips 2-3 shift - (install pressure gauge).	1. Oil level low.	1. Add oil. See paragraph 75-36, subparagraph E.
	2. Oil pressure low. Refer to paragraph 75-6.	2a. Modulator assembly. b. Modulator valve. c. Pump pressure regulator valve or boost valve; pump to case gasket off location.
	3. Case	3. Porosity
	4. Direct clutch.	4a. Piston seals leaking, or ball check leak.
Rough 2-3 shift - (install pressure gauge).	1. Oil pressure high - refer to paragraph 75-6.	1a. Vacuum leak. b. Modulator valve sticking. c. Valve body - pressure regulator or boost valve inoperative.
	2. 2-3 accumulator assembly.	2a. 2-3 accumulator spring missing, broken. b. Accumulator piston stuck.
No engine braking - L2 - 2nd gear.	1. Intermediate servo and 2-3 accumulator.	1a. Servo or accumulator oil rings or bores leaking.

		b. Servo piston stuck.
	2. Intermediate overrun band.	2. Intermediate overrun band broken, burned (check for cause).
	3. Oil pressure low.	3. Pressure regulator and/or boost valve stuck.
No engine braking - L1 - 1st gear.	1. Manual low control valve assembly.	1. Stuck
	2. Oil pressure low.	2. Pressure regulator and/or boost valve stuck.
	3. Low and reverse clutch.	3. Piston inner seal damaged or missing.
No part throttle downshift - (install pressure gauge).	1. Oil pressure. Refer to paragraph 75-6.	1a. Vacuum modulator assembly, modulator valve, pressure regulator valve train (other malfunctions may also be noticed).
	2. Detent valve and linkage.	2. Sticks or disconnected or broken.
	3. 2-3 shift valve.	3. Stuck
No detent downshifts.	1. Control valve assembly.	1. 2-3 valve stuck.
	2. Detent valve and linkage.	2. Sticks or disconnected or broken.
Low or high shift points - (install pressure gauge).	1. Oil pressure. Refer to paragraph 75-6.	1a. Engine vacuum - check at transmission end of the modulator pipe. 1b. Vacuum modulator assembly, vacuum line connections at engine and transmission, modulator valve, pressure regulator valve train.
	2. Governor	2a. Valve sticking. b. Feed holes restricted or leaking, pipes damaged or mispositioned. c. Feed line plugged.
	3. Detent valve and linkage.	3. Stuck open. (Will cause late shifts.)
	4. Control valve assembly.	4a. 2-3 valve train sticking. b. 1-2 shift valve train sticking.
	5. Case	5. Porosity
Won't hold in "Park".	1. Manual linkage.	1. Misadjusted
	2. Internal linkage.	2a. Parking brake lever and actuator assembly - defective. Check for chamfer on actuator rod sleeve. b. Parking pawl broken or inoperative.

## 75-6 HYDRAULIC PRESSURE CHECKS

Selector Lever In:	Upshifts (MPH)		Downshifts (MPH)	
	1-2	2-3	3-2	3 or 2-1
<b>Drive Range</b>				
Full Throttle	50	85	(75)	(40)
Minimum Throttle	10	22	—	—
Part Throttle			(50)	—
Coast	—	—	22	9
			(N) Lockout Speed	

L<sub>1</sub> (MAN. LOW) — (ENGINE BRAKING @ 46 MPH OR BELOW)

L<sub>2</sub> (MAN. 2ND) — (ENGINE BRAKING @ ANY SPEED)

## CAR TEST — LINE PRESSURE CHECKS

(A) Car coasting @ 25 MPH—Vacuum line connected—  
foot OFF throttle.

## CAR STATIONARY — (SERVICE BRAKE ON)

(B) Oil pressures indicated are at zero output speed with  
the vacuum line disconnected from the modulator as-  
sembly and with the engine at 1200 rpm.

Range	Minimum PSI	Alt. of Check Ft. Above Sea Level	Drive Neutral Park	L <sub>2</sub> or L <sub>1</sub>	Rev.
Park/Neutral	60	0	153	153	239
Reverse	86	2,000	153	153	224
Drive	60	4,000	145	147	205
L <sub>2</sub>	85	6,000	134	139	191
L <sub>1</sub>	85	8,000	124	132	176
		10,000	115	125	164
		12,000	106	118	151
		14,000	98	112	139

NOTE: Altitude and pressures are approximate.

## ROAD TEST — (With Vacuum Line and Gage Installed)

	Minimum PSI	Maximum PSI
Drive — 1st (0 to WOT)	60	153
— 2nd (0 to WOT)	60	153
— 3rd (Coast @ 30 MPH)	60	—
Reverse (0 to WOT)	86	239
L <sub>1</sub> (Coast @ 30 MPH)	85	—
L <sub>2</sub> (Coast @ 30 MPH)	85	—

TURBO HYDRA-MATIC 350-375B  
DIAGNOSIS CHART

PROBLEM	CAR ROAD TEST	ALL RANGES-SLIPS	DRIVE-SLIPS-NO 1ST GEAR	LINE PRESSURE-ALL LOW	1-2 INTERM. CL. PRES. HIGH	2-3 INTERM. CL. PRES. HIGH	2-3 DIRECT CL. PRES. HIGH	NO 1-2 UPSHIFT	1-2 U.S. EARLY/LATE	1-2 UPSHIFT @ W.O.T. ONLY	SLIPS-1-2 UPSHIFT	ROUGH-1-2 UPSHIFT	NO 2-3 UPSHIFT	2-3 U.S. EARLY/LATE	SLIPS-2-3 UPSHIFT	ROUGH-2-3 UPSHIFT	NO WOT-2-3 UPSHIFT	NO PART TH. DOWNSHIFT	2-3 UP/SHIF. DOWNSHIFT	NO-FULL TH. DOWNSHIFT	HARSH-DOWNSHIFT	L1 RANGE-DOWNSHIFT	L2 RANGE-NO ENG. BRAKING	NEUTRAL-NO ENG. BRAKING	REVERSE-NO ENG. BRAKING	SLIPS IN REVERSE	PARK-NO PARK-RATCHETS	NOISY-ALL RANGES	REV. & D. L1 & L2 NOISY	LOW COOLER-FLOW	SPMS OIL OUT BREATHER												
LOW OIL LEVEL/WATER IN OIL		X	X	X	X	X	X	X	X	X	X	X	X	X	X	X	X	X	X	X	X	X	X	X	X	X	X	X	X	X	X	X											
VACUUM LEAK		X	X	X	X	X	X	X	X	X	X	X	X	X	X	X	X	X	X	X	X	X	X	X	X	X	X	X	X	X	X	X	X										
MODULATOR & / OR VALVE		X	X	X	X	X	X	X	X	X	X	X	X	X	X	X	X	X	X	X	X	X	X	X	X	X	X	X	X	X	X	X	X	X									
STRAINER & / OR GASKET		X	X	X	X	X	X	X	X	X	X	X	X	X	X	X	X	X	X	X	X	X	X	X	X	X	X	X	X	X	X	X	X	X	X								
GOVERNOR-VALVE/SCREEN		X	X	X	X	X	X	X	X	X	X	X	X	X	X	X	X	X	X	X	X	X	X	X	X	X	X	X	X	X	X	X	X	X	X	X							
VALVE BODY-GASKET/PLATE		X	X	X	X	X	X	X	X	X	X	X	X	X	X	X	X	X	X	X	X	X	X	X	X	X	X	X	X	X	X	X	X	X	X	X	X						
PRES. REG. & / OR BOOST VALVE		X	X	X	X	X	X	X	X	X	X	X	X	X	X	X	X	X	X	X	X	X	X	X	X	X	X	X	X	X	X	X	X	X	X	X	X						
BALL (#1) SHY		X	X	X	X	X	X	X	X	X	X	X	X	X	X	X	X	X	X	X	X	X	X	X	X	X	X	X	X	X	X	X	X	X	X	X	X	X					
1-2 SHIFT VALVE																																											
2-3 SHIFT VALVE																																											
MANUAL LOW CONT'L VALVE																																											
DETENT VALVE & LINKAGE																																											
DETENT REG. VALVE																																											
2-3 ACCUMULATOR																																											
MANUAL VALVE/LINKAGE		X	X	X	X	X	X	X	X	X	X	X	X	X	X	X	X	X	X	X	X	X	X	X	X	X	X	X	X	X	X	X	X	X	X	X	X	X	X	X	X		
POROSITY/CROSS LEAK		X	X	X	X	X	X	X	X	X	X	X	X	X	X	X	X	X	X	X	X	X	X	X	X	X	X	X	X	X	X	X	X	X	X	X	X	X	X	X	X	X	
PUMP-GEARS		X	X	X	X	X	X	X	X	X	X	X	X	X	X	X	X	X	X	X	X	X	X	X	X	X	X	X	X	X	X	X	X	X	X	X	X	X	X	X	X	X	
PRIMING VALVE SHY		X	X	X	X	X	X	X	X	X	X	X	X	X	X	X	X	X	X	X	X	X	X	X	X	X	X	X	X	X	X	X	X	X	X	X	X	X	X	X	X	X	
COOLER VALVE LEAK		X	X	X	X	X	X	X	X	X	X	X	X	X	X	X	X	X	X	X	X	X	X	X	X	X	X	X	X	X	X	X	X	X	X	X	X	X	X	X	X	X	
CLUTCH SEAL RINGS		X	X	X	X	X	X	X	X	X	X	X	X	X	X	X	X	X	X	X	X	X	X	X	X	X	X	X	X	X	X	X	X	X	X	X	X	X	X	X	X	X	
POROUS/CROSS LEAK		X	X	X	X	X	X	X	X	X	X	X	X	X	X	X	X	X	X	X	X	X	X	X	X	X	X	X	X	X	X	X	X	X	X	X	X	X	X	X	X	X	
GASKET SCREEN-PRESSURE		X	X	X	X	X	X	X	X	X	X	X	X	X	X	X	X	X	X	X	X	X	X	X	X	X	X	X	X	X	X	X	X	X	X	X	X	X	X	X	X	X	X
BAND-INTERM. O.R.		X	X	X	X	X	X	X	X	X	X	X	X	X	X	X	X	X	X	X	X	X	X	X	X	X	X	X	X	X	X	X	X	X	X	X	X	X	X	X	X	X	
CASE-POROUS/X LEAK		X	X	X	X	X	X	X	X	X	X	X	X	X	X	X	X	X	X	X	X	X	X	X	X	X	X	X	X	X	X	X	X	X	X	X	X	X	X	X	X	X	X
1-2 ACCUMULATOR		X	X	X	X	X	X	X	X	X	X	X	X	X	X	X	X	X	X	X	X	X	X	X	X	X	X	X	X	X	X	X	X	X	X	X	X	X	X	X	X	X	X
INTERMED. SERVO		X	X	X	X	X	X	X	X	X	X	X	X	X	X	X	X	X	X	X	X	X	X	X	X	X	X	X	X	X	X	X	X	X	X	X	X	X	X	X	X	X	X
FORWARD CLUTCH ASS'Y		X	X	X	X	X	X	X	X	X	X	X	X	X	X	X	X	X	X	X	X	X	X	X	X	X	X	X	X	X	X	X	X	X	X	X	X	X	X	X	X	X	X
DIRECT CLUTCH ASS'Y		X	X	X	X	X	X	X	X	X	X	X	X	X	X	X	X	X	X	X	X	X	X	X	X	X	X	X	X	X	X	X	X	X	X	X	X	X	X	X	X	X	X
INTERMED. CL. ASS'Y		X	X	X	X	X	X	X	X	X	X	X	X	X	X	X	X	X	X	X	X	X	X	X	X	X	X	X	X	X	X	X	X	X	X	X	X	X	X	X	X	X	
L & REV. CL. ASS'Y		X	X	X	X	X	X	X	X	X	X	X	X	X	X	X	X	X	X	X	X	X	X	X	X	X	X	X	X	X	X	X	X	X	X	X	X	X	X	X	X	X	X
INT. ROLLER CL. ASS'Y		X	X	X	X	X	X	X	X	X	X	X	X	X	X	X	X	X	X	X	X	X	X	X	X	X	X	X	X	X	X	X	X	X	X	X	X	X	X	X	X	X	
L. & R. ROLLER CL. ASS'Y		X	X	X	X	X	X	X	X	X	X	X	X	X	X	X	X	X	X	X	X	X	X	X	X	X	X	X	X	X	X	X	X	X	X	X	X	X	X	X	X	X	
PARK PAWL/LINKAGE		X	X	X	X	X	X	X	X	X	X	X	X	X	X	X	X	X	X	X	X	X	X	X	X	X	X	X	X	X	X	X	X	X	X	X	X	X	X	X	X	X	
CONVERTER ASS'Y		X	X	X	X	X	X	X	X	X	X	X	X	X	X	X	X	X	X	X	X	X	X	X	X	X	X	X	X	X	X	X	X	X	X	X	X	X	X	X	X	X	
GEAR SET & BEARINGS		X	X	X	X	X	X	X	X	X	X	X	X	X	X	X	X	X	X	X	X	X	X	X	X	X	X	X	X	X	X	X	X	X	X	X	X	X	X	X	X	X	



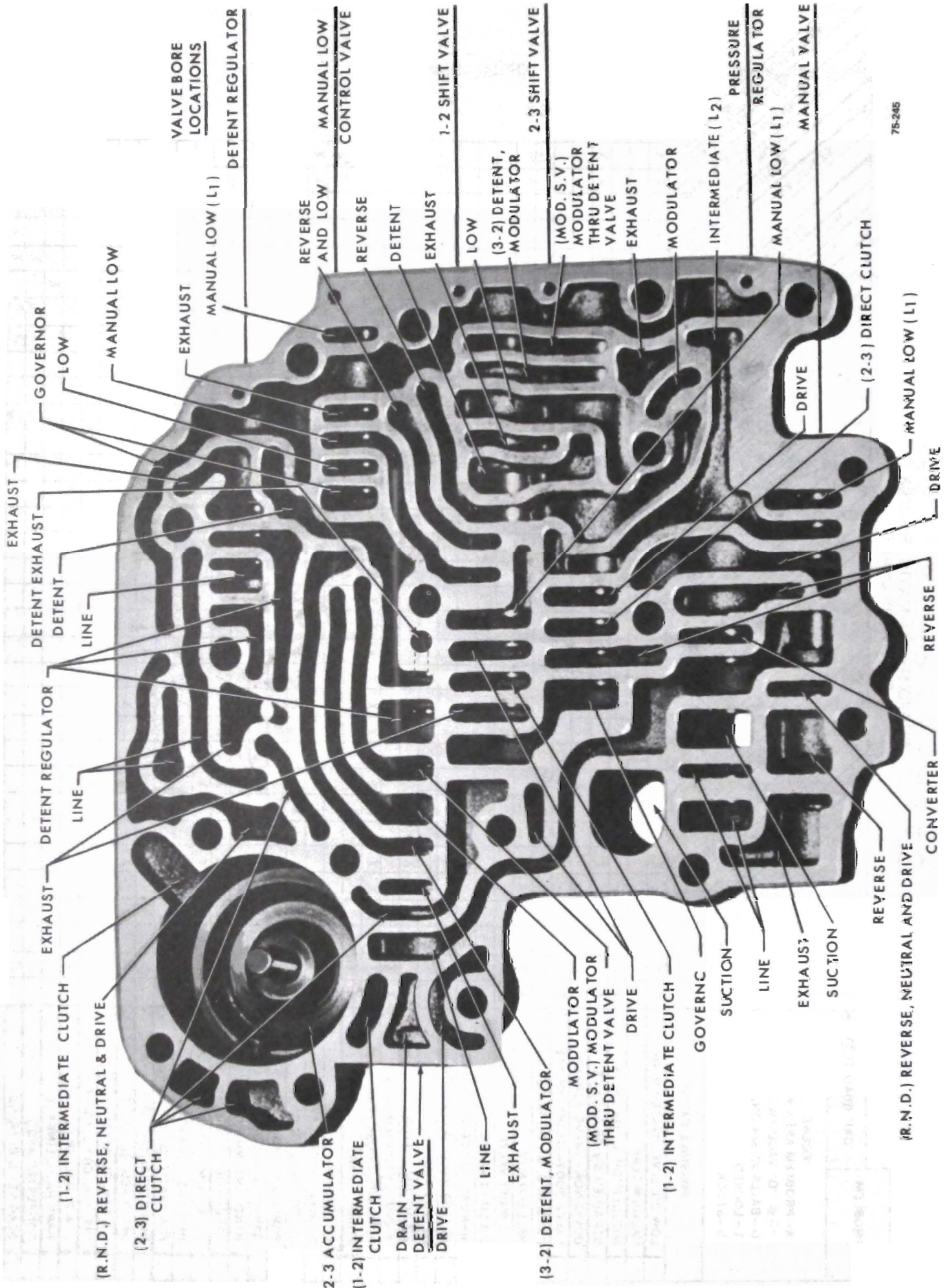

Figure 75-6 - Identification of Oil Channels in Valve Body

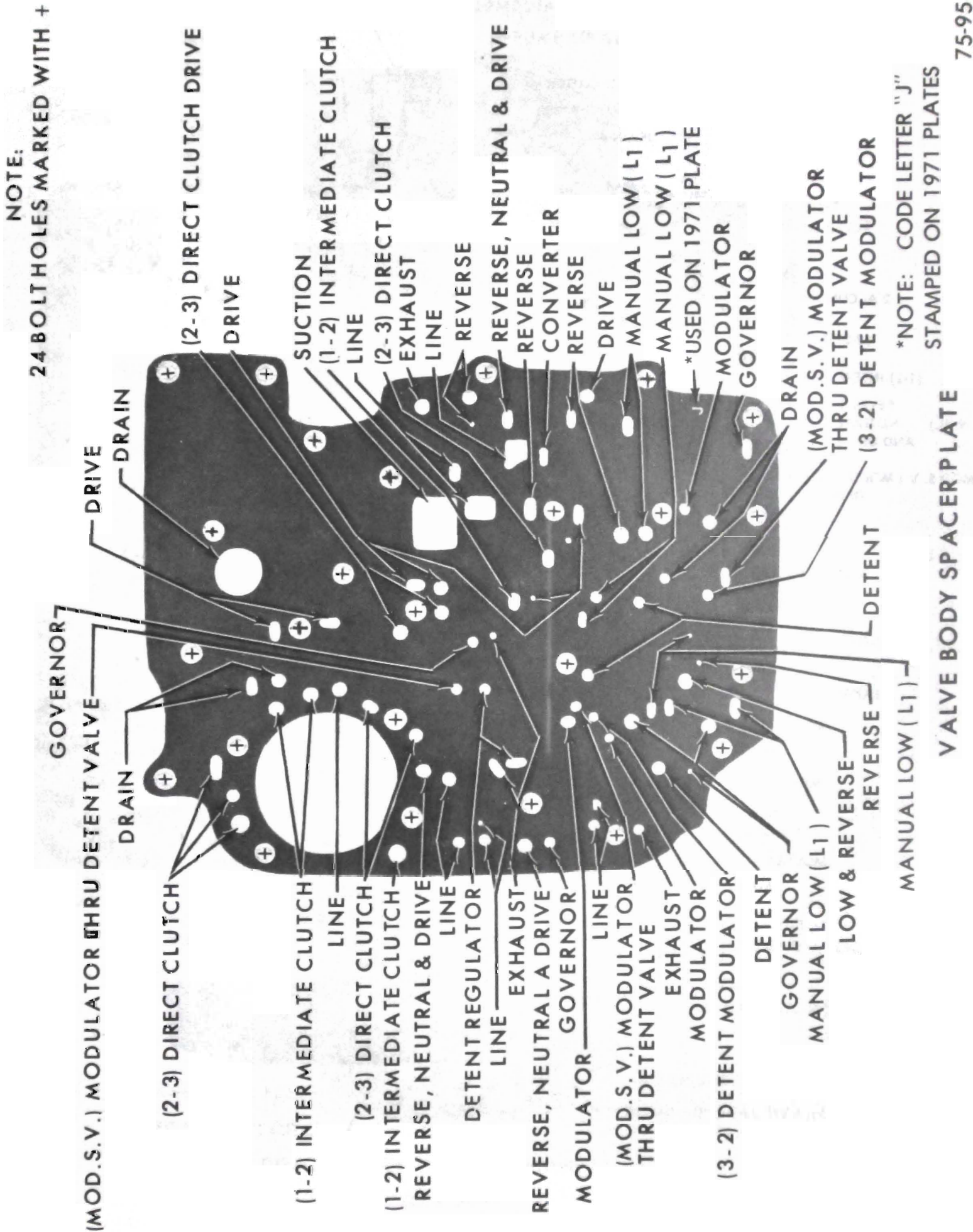

Figure 75-7 · Valve Body Spacer Plate



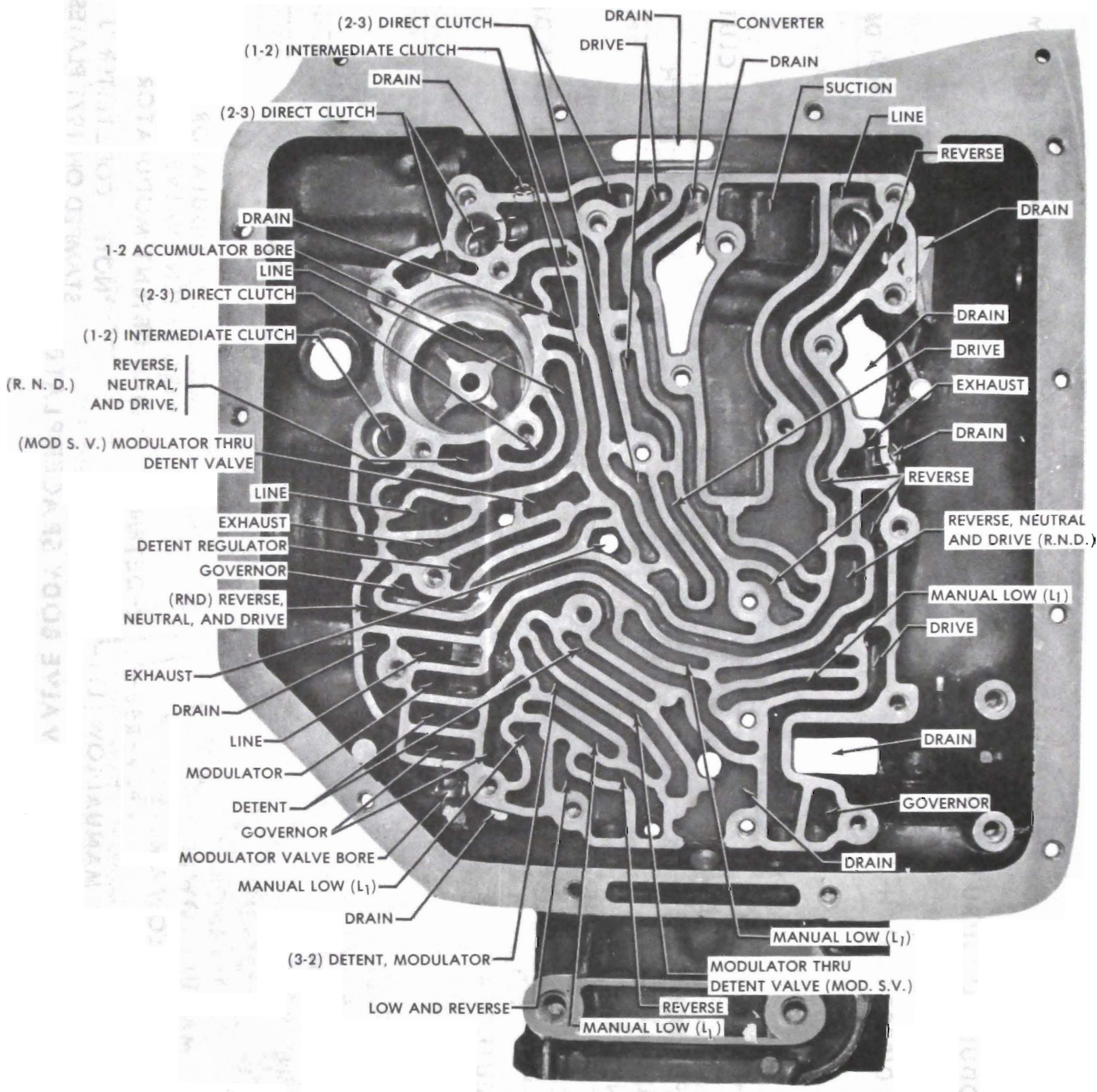
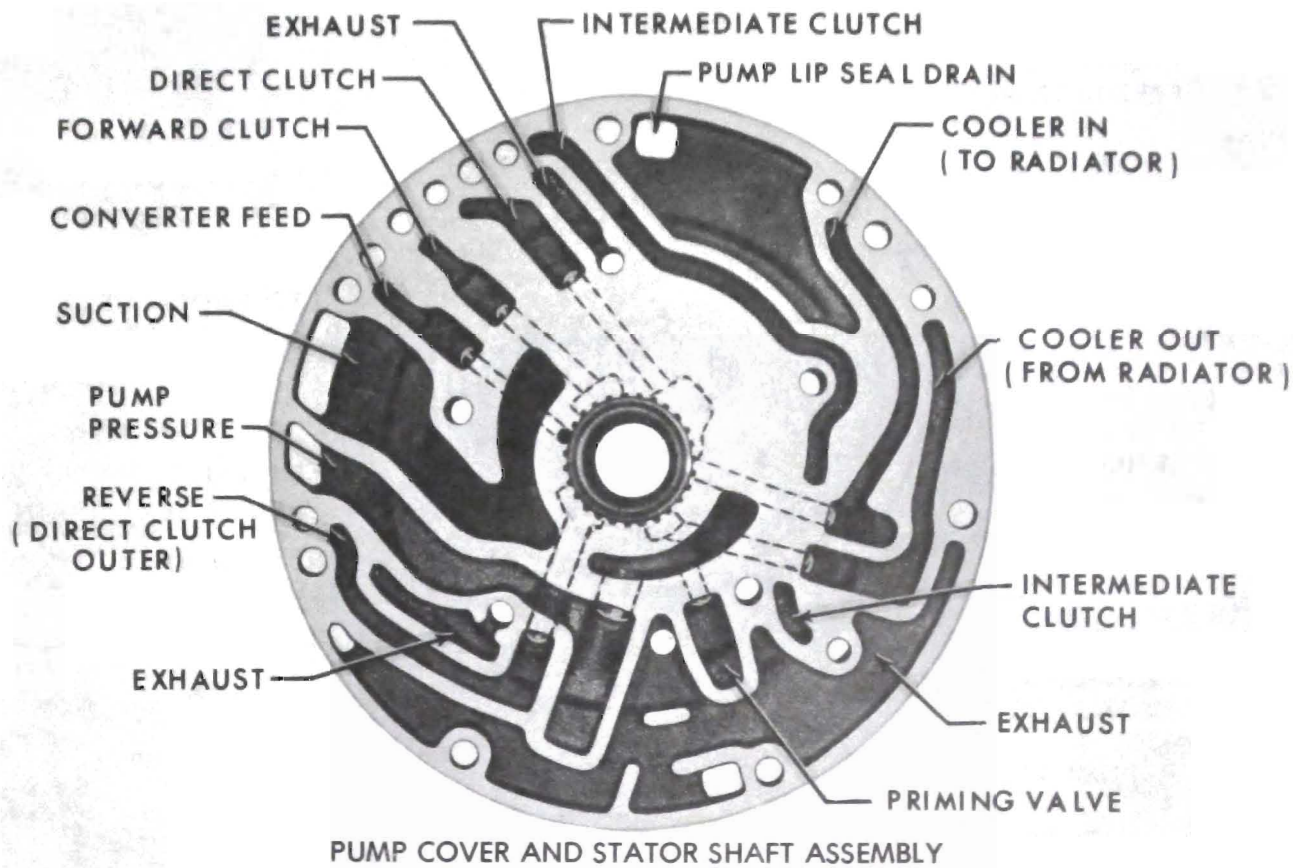
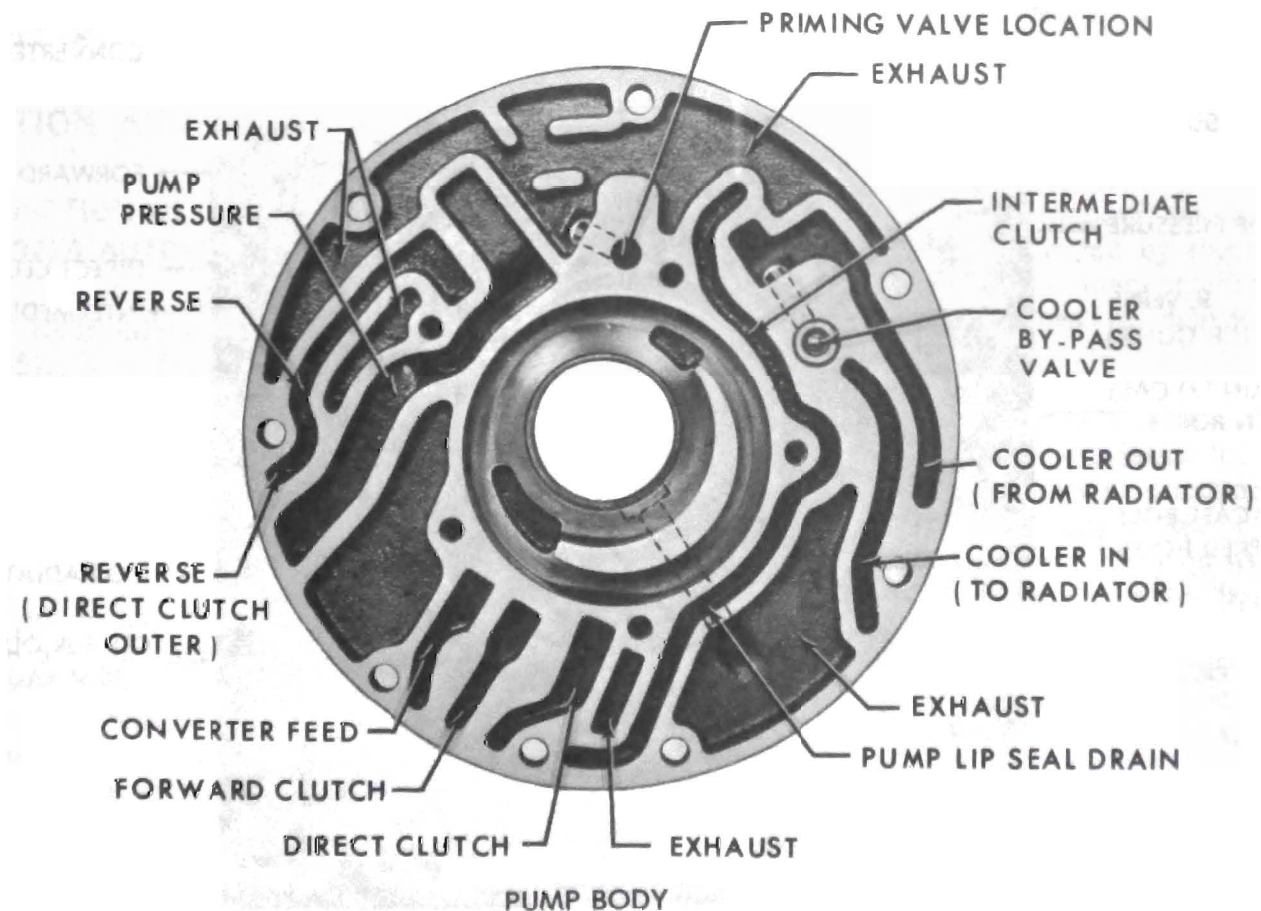

Figure 75-8 - Identification of Oil Channels in Case Face



75-110

Figure 75-9 - Identification of Oil Channels in Pump Cover and Stator Shaft Face



75-109

Figure 75-10 - Identification of Oil Channels in Pump Body Front Face



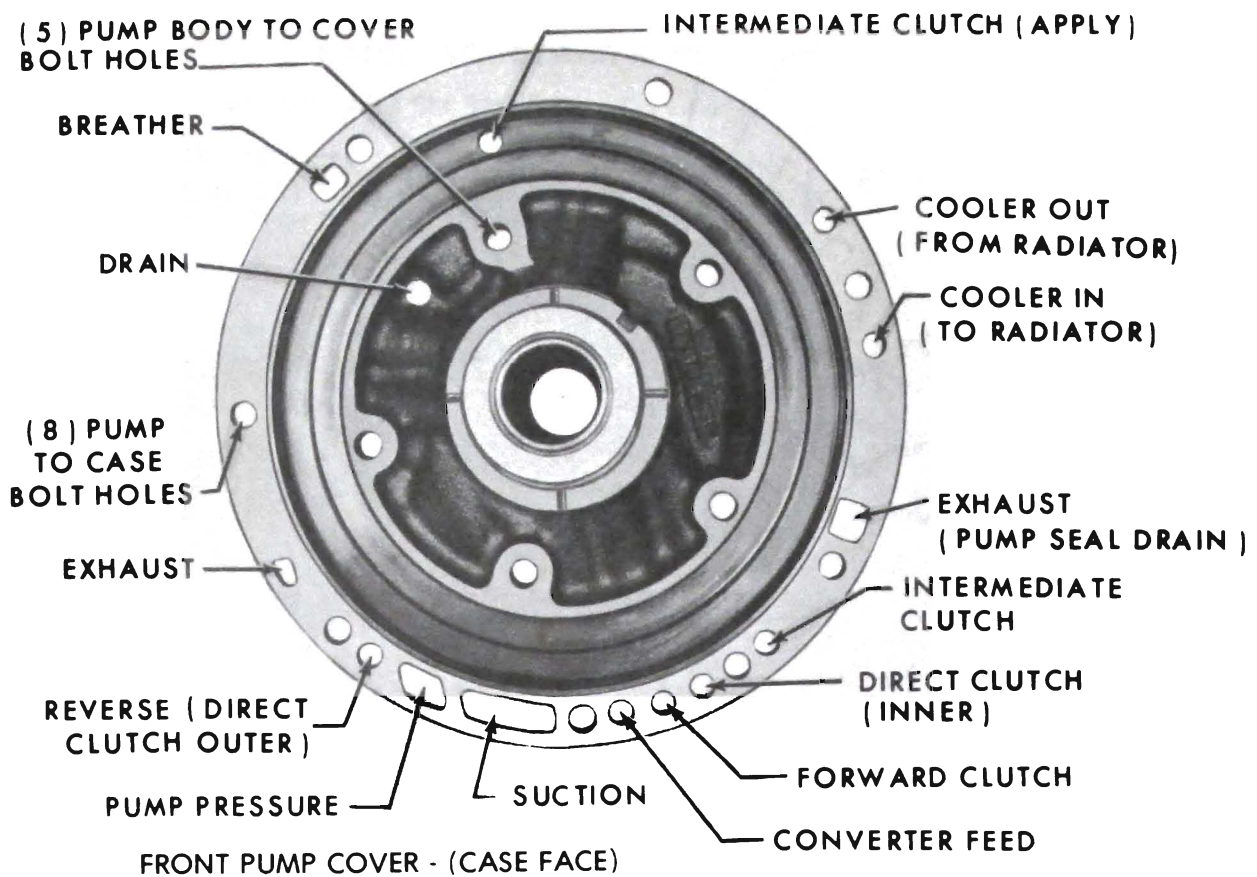

75-111

Figure 75-11 - Identification of Oil Channels in Pump Cover Rear Face

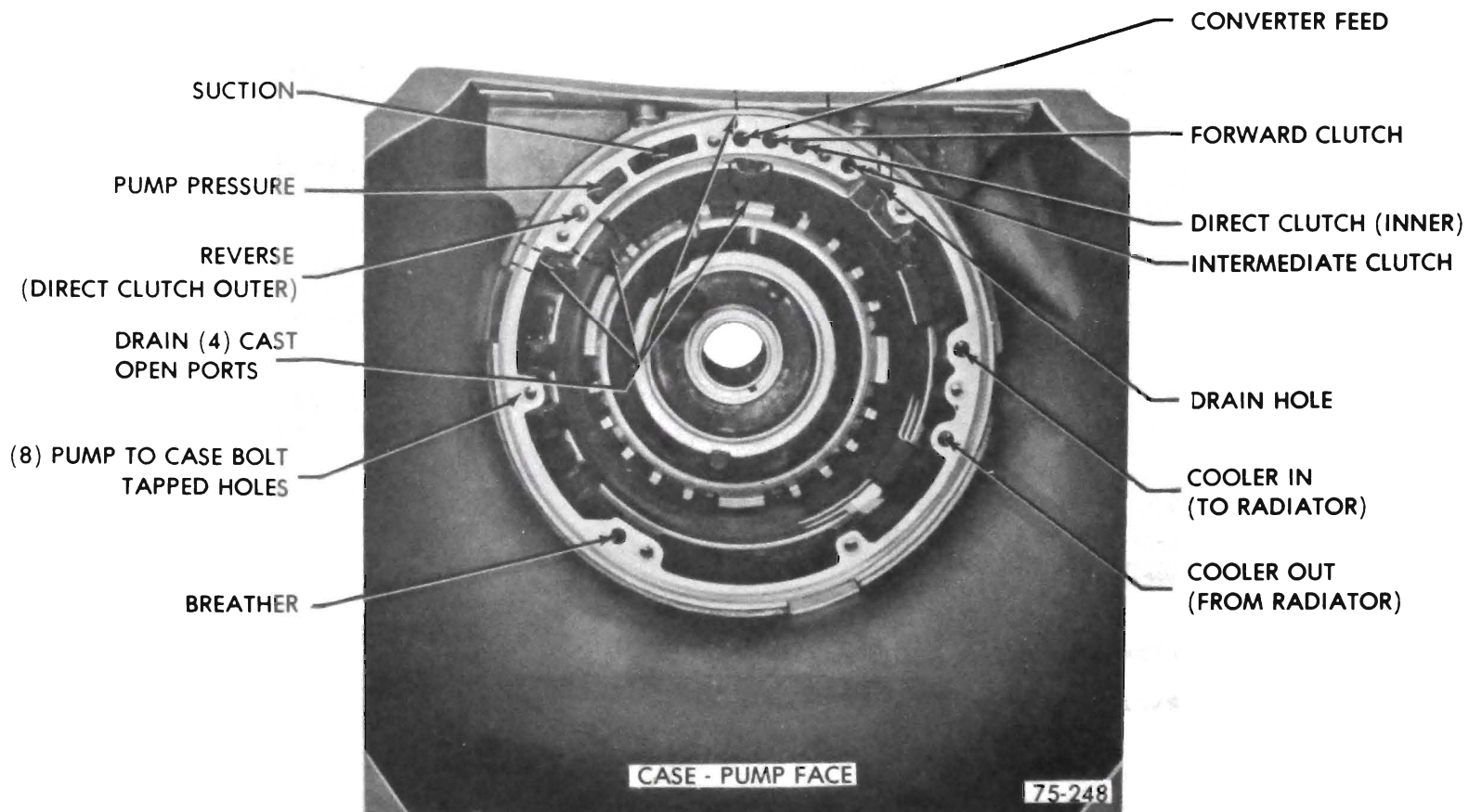

Figure 75-12 - Case - Pump Identification of Oil Channels

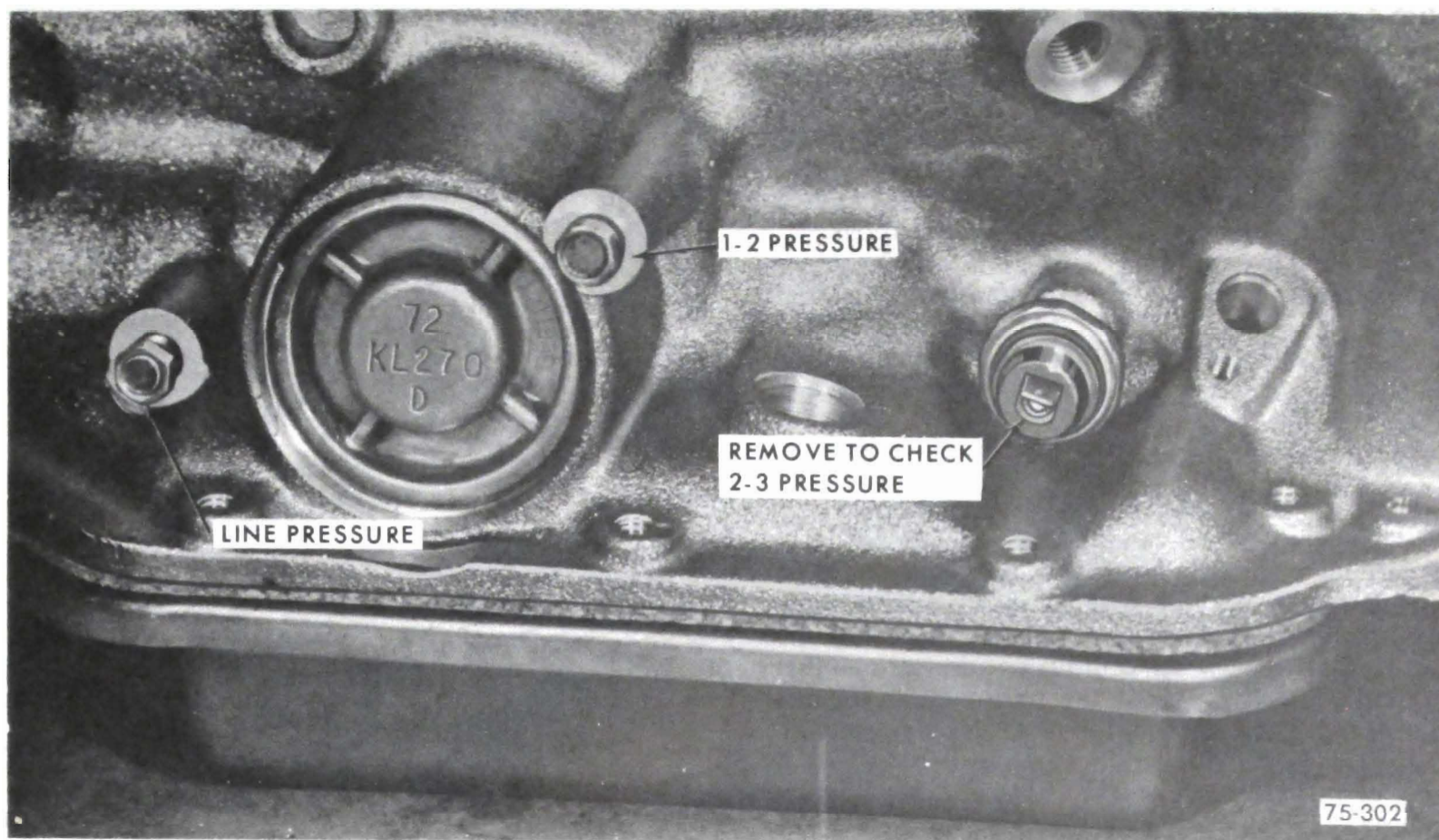

Figure 75-13 - Locating of Taps For Hydraulic Pressure Checks

## DIVISION II

### DESCRIPTION AND OPERATION

#### 75-7 DESCRIPTION OF TURBO HYDRA-MATIC 350-375B AUTOMATIC TRANSMISSION

The Turbo Hydra-Matic 350-375B transmission, see Figure 75-51, is a fully automatic unit consisting primarily of 3-element hydraulic torque converter and two planetary gear sets. Four multiple-disc clutches, two roller clutches, and an intermediate overrun band provide the friction elements required to obtain the desired function of the two planetary gear sets.

The 3-element torque converter consists of a pump, turbine and a stator assembly. The stator is mounted on a one way roller clutch which will allow the stator to turn clockwise, but not counterclockwise. References to clockwise and counterclockwise are determined by looking toward rear of car.

The torque converter is of welded construction and is serviced as a complete assembly. The unit is filled with oil and is attached to the engine crankshaft by a flywheel, thus always rotates at engine speed. The converter pump is an integral part of the converter housing, therefore, the pump blades, rotating at engine

speed, set the oil within the converter into motion and direct it to the turbine, causing the turbine to rotate.

As the oil passes throughout the turbine it is traveling in such a direction that if it were not redirected by the stator it would hit the rear of the converter pump blades and impede its pumping action. So at low turbine speeds, oil is redirected by the stator to the converter pump in such a manner that it actually assists the converter pump to deliver power, or multiply engine torque.

As turbine speed increases, the direction of oil leaving the turbine changes and flows against the rear side of the stator vanes in a clockwise direction. Since the stator is now impeding the smooth flow of oil, its roller clutch releases and it revolves freely on its shaft. Once the stator becomes inactive, there is no further multiplication of engine torque within the converter. At this point, the converter is merely acting as a fluid coupling as both the converter pump and turbine are being driven at approximately the same speed.

A hydraulic system pressurized by a gear type pump provides the working pressure required to operate the friction elements and automatic controls.

Operation of the turbo-hydrumatic 375B transmission is identical to the 350, with the physical difference being an increase in the number of direct clutch plates from four to five. This will increase torque capacity.



**High Output Oil Pump** - To be selected for maximum output from the current production assemblies.

**Close Limit Governor and Modulator** - To provide more precise pressure control.

**High Capacity Transmission Oil Cooler** - Same as used with current Upper Series THM-400 transmissions.

External control connections to the transmission are:

1. Manual Linkage - To select the desired operating range.
2. Engine Vacuum - To operate the vacuum modulator.
3. Cable Control - To operate the detent valve.

A vacuum modulator is used to automatically sense any change in the torque input to the transmission. The vacuum modulator transmits this signal to the pressure regulator, which controls line pressure, so that all torque requirements of the transmission are met and smooth shifts are obtained at all throttle openings.

The detent valve is activated by a cable that is connected to the accelerator lever assembly. When the throttle is half open, the valve is actuated causing throttle downshift at speeds below 50 mph. When the throttle is fully open the detent valve is actuated causing the transmission to downshift from 3-1 at speeds below 40 mph and 3-2 below 75 mph.

## 75-8 FUNCTIONS OF VALVES AND HYDRAULIC CONTROL UNITS

### A. Pressure Control

The transmission is controlled automatically by a hydraulic system. Hydraulic pressure is supplied by the transmission oil pump, see Figure 75-14, which is engine driven. Main line pressure is controlled by a pressure regulator valve train and by the vacuum modulator which is connected to engine vacuum. The pressure regulator valve train controls line pressure automatically, in response to a pressure signal from a modulator valve, in such a way that the torque requirements of the transmission clutches are met and proper shift spacing is obtained at all throttle openings. To control line pressure properly, a modulator pressure is used which varied in the same manner as torque input to the transmission. Modulator pressure is regulated by engine vacuum which is an indicator of engine torque and carburetor opening.

### B. Vacuum Modulator Assembly

The engine vacuum signal is provided by the vacuum modulator, which consists of an evacuated metal bellows, a diaphragm and two springs. See Figure 75-

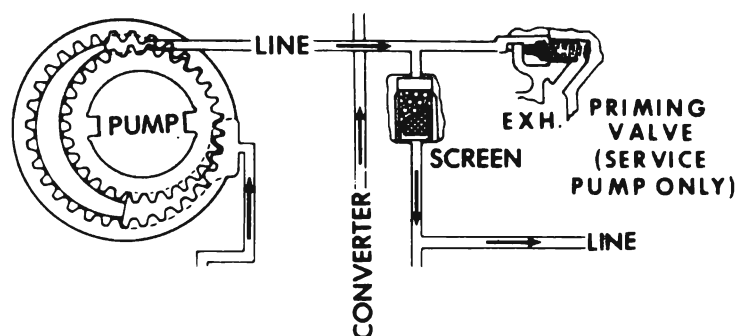

75-158

Figure 75-14 - Oil Pump

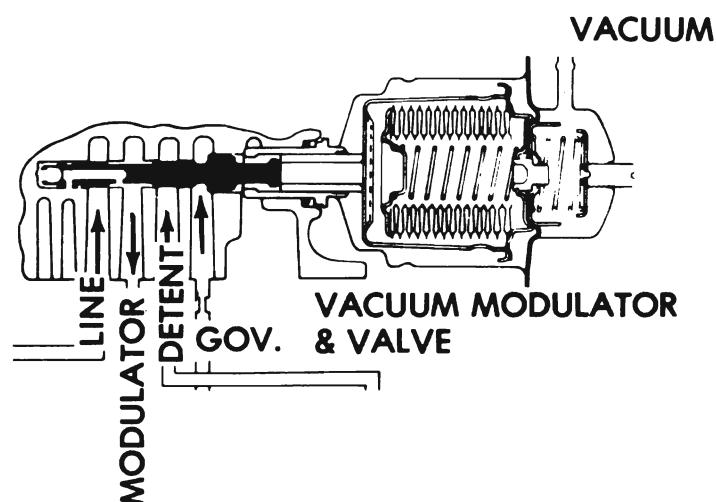

75-151

Figure 75-15 - Vacuum Modulator Assembly

15. These are so arranged that when installed, the bellows and its external spring apply a force which acts on the modulator valve. This force acts on the modulator valve so that it increases modulator pressure. Engine vacuum and the other spring acts in the opposite direction to decrease modulator, or low engine vacuum, high modulator pressure; high engine vacuum, and low modulator pressure. To reduce the effect of engine power loss at high altitudes on shift points, the effective area of the diaphragm is made somewhat larger than that of the bellows. Atmospheric

pressure then acts on the resulting differential area to reduce modulator pressure.

R, N, D, L1, L2, as selected by the vehicle operator through the manual selector lever.

**C. Governor Assembly (See Figure 75-16)**

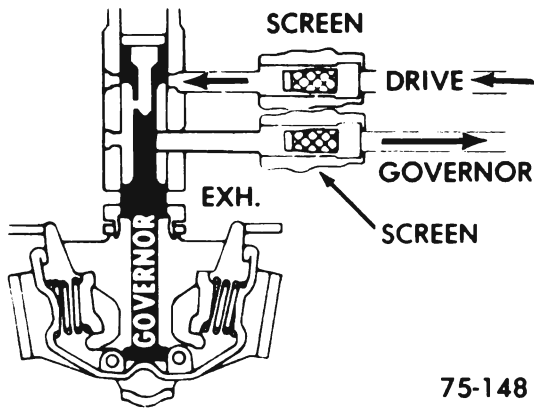

Figure 75-16 - Governor Assembly

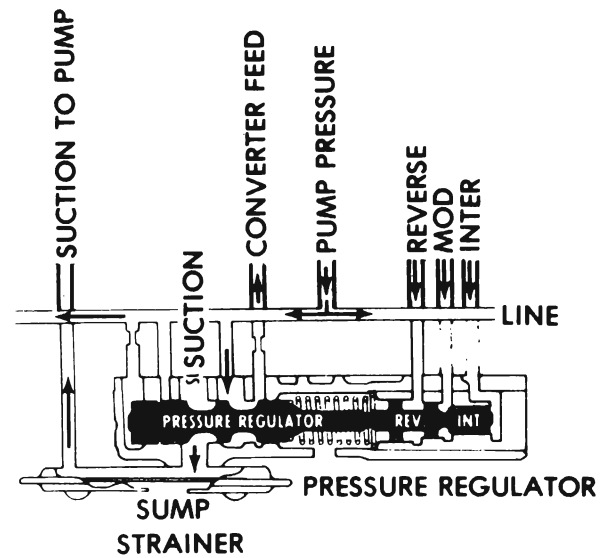

Figure 75-17 - Pressure Regulator Valve

The vehicle speed signal to the modulator valve is supplied by the transmission governor, which is driven by the output shaft. The governor consists of a pair of dual weights and a regulator valve.

As the car begins to move the weight assemblies move outward to provide a regulating force against the valve through the springs between the primary and secondary weights. As car speed is further increased, regulating force against the valve is provided by the secondary weights moving outward. At approximately 22 MPH the primary weights have reached the limit of their travel and the force against the valve is then entirely through the secondary weights.

Thus, governor valve pressure is determined at very low speeds by the primary and secondary weights and at higher speeds by the secondary weights plus the force of the springs between the weights. In this manner governor pressure is increased rapidly but smoother from very low speeds to approximately 22 MPH, where it increases at a slower rate.

**D. Pressure Regulator Valve (See Figure 75-17)**

1. Regulates line pressure according to a fixed spring force and forces controlled by modulator intermediate and reverse pressure.

2. Controls flow of oil that charges the torque converter, feeds the oil cooler and provides lubrication and oil for clutch applications.

**E. Manual Valve (See Figure 75-18)**

Establishes the range of transmission operation, i.e., P,

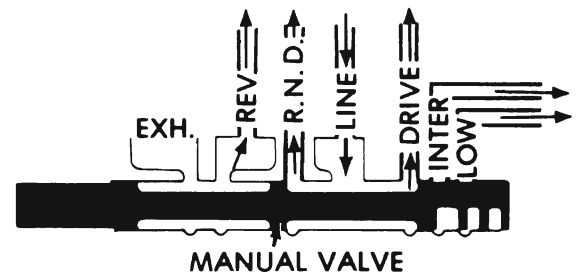

Figure 75-18 - Manual Valve

**F. Modulator Valve (See Figure 75-19)**

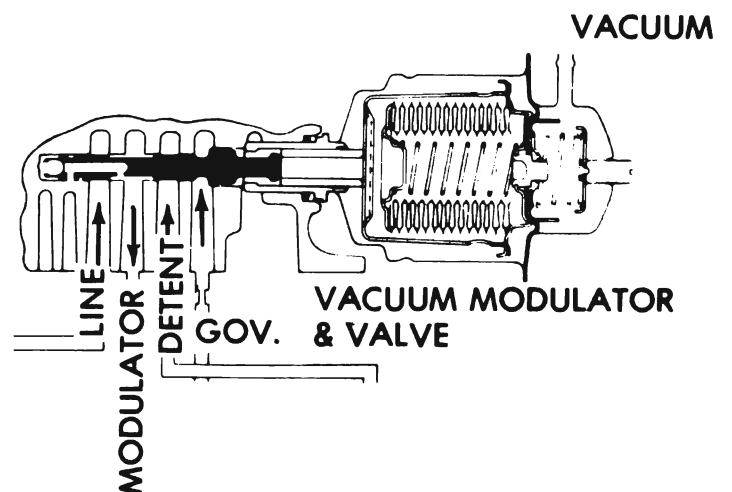

Figure 75-19 - Modulator Valve



Regulates line pressure to modulator pressure that varies with torque to the transmission. It senses forces created by:

1. The vacuum modulator bellows that increases modulator pressure.
2. Engine vacuum acting on a diaphragm to decrease modulator pressure.
3. Governor pressure which is generated by the governor assembly. Governor pressure tends to decrease modulator pressure.

**G. 1-2 Accumulator (See Figure 75-20)**

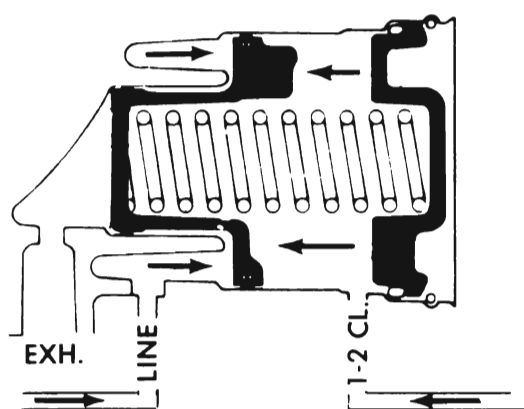

75-152

Figure 75-20 - 1-2 Accumulator

Line pressure routed to the 1-2 accumulator causes the piston to cushion application of the intermediate clutch. The spring within the accumulator acts against the piston. The force of the spring and the pressure of the 1-2 clutch oil push the 1-2 accumulator piston back towards the line oil to allow a gradual build up of the 1-2 clutch pressure.

**H. 2-3 Accumulator (See Figure 75-21)**

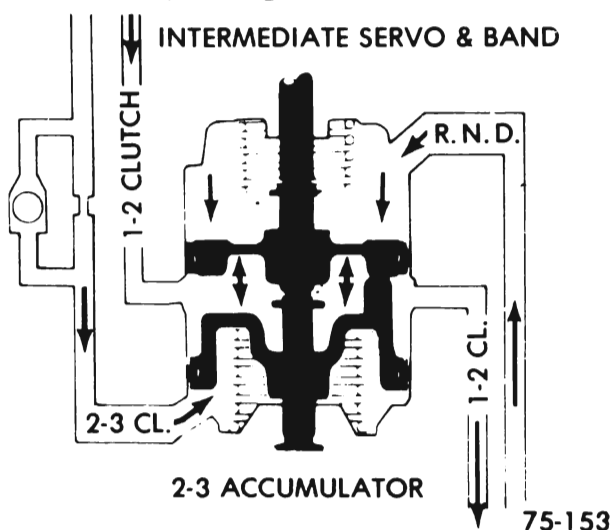

75-153

Figure 75-21 - 2-3 Accumulator

Oil routed to the 2-3 accumulator cushions the application of the direct clutch. The spring within the accumulator acts against the piston. The force of the spring and the pressure of the 2-3 clutch oil push the 2-3 accumulator piston back towards the R, D, N oil to allow a gradual build up of the 2-3 clutch pressure.

**I. 1-2 Shift Valve (See Figure 75-22)**

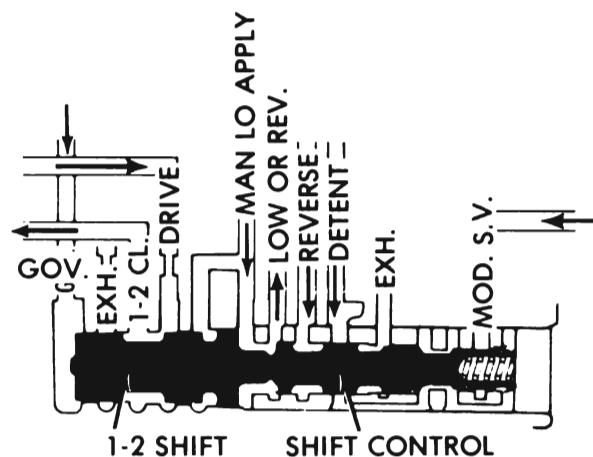

75-154

Figure 75-22 - 1-2 Shift Valve

Routes oil pressure that causes the transmission to shift from 1-2 or 2-1. Its operation is controlled by governor pressure, detent pressure, modulator pressure, and spring force. See Figure 75-22.

**J. 2-3 Shift Valve (See Figure 75-23)**

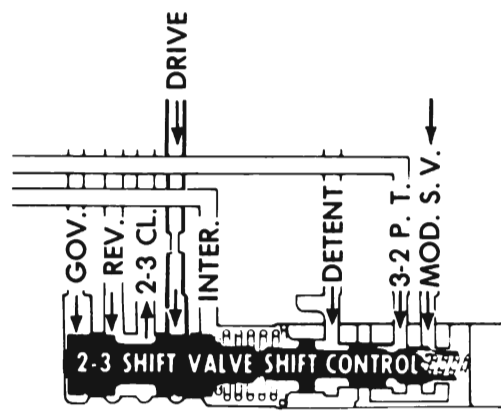

75-155

Figure 75-23 - 2-3 Shift Valve

Routes oil pressure that causes the transmission to shift from 2-3 or 3-2. Its operation is controlled by modulator, governor, detent and modulator, valves pressures as well as a spring force.

**K. Detent Valve (Actuated by Cable Linkage From Throttle Linkage) (See Figure 75-24)**

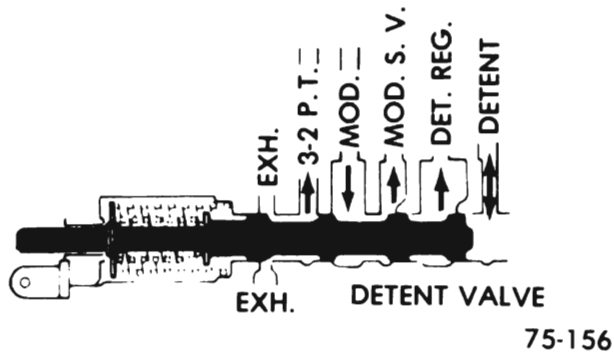

Figure 75-24 - Detent Valve

Directs regulated modulator pressure tending to hold the 1-2 shift and 2-3 shift valves in the downshift position and provides areas for modulator and detent regulated pressures for detent 2-1, 3-1, and 3-2 downshifts.

**L. Detent Regulator Valve (See Figure 75-25)**

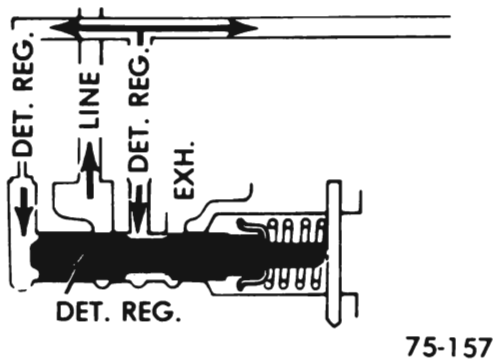

Figure 75-25 - Detent Regulator Valve

The detent regulator valve and spring regulate line pressure into detent regulator oil which is used to control the car speed at which the 1-2 and 2-3 upshifts occur.

**M. Cooler By-Pass Valve (See Figure 75-26)**

The cooler by-pass valve permits oil to be fed directly from the converter to the lubrication circuit when the oil is very cold or if the cooler or lines should become restricted.

**N. Manual Low Control Valve (See Figure 75-27)**

The manual low control valve is positioned to exhaust the manual low apply line when the manual valve is placed in the manual low (L1) position above approximately 50 MPH. At speeds below 50 MPH low

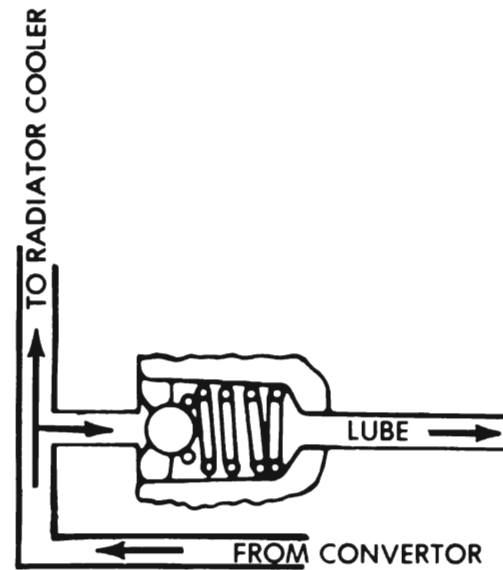

75-159

Figure 75-26 - Cooler By-Pass Valve

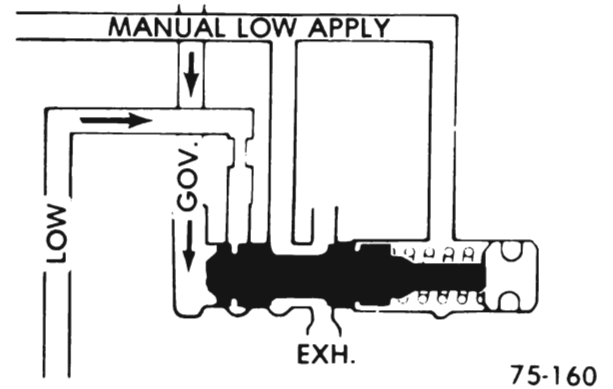

Figure 75-27 - Manual Low Control Valve

oil is fed into the manual low apply line which move the 1-2 shift valve to the downshifted position (exhausting the 1-2 clutch) and moves the 1-2 shift control valve to the upshifted position which sends low apply oil to the low and reverse clutch which engages this clutch. Once the manual low control valve is in the downshifted position, its spring plus low apply oil acting on it will keep it in this position; therefore, with the transmission in manual low (L1 range), the transmission cannot upshift to intermediate (second gear) regardless of vehicle or engine speed once low gear has been engaged.

The manual low control valve is used also to protect the engine by preventing low range engagement (indicated by high car speed which is sensed by high governor pressure) at car speeds over 50 MPH.

75-9 MECHANICAL OPERATION

1. OPERATION OF COMPONENTS IN PARK (P) OR NEUTRAL (N)

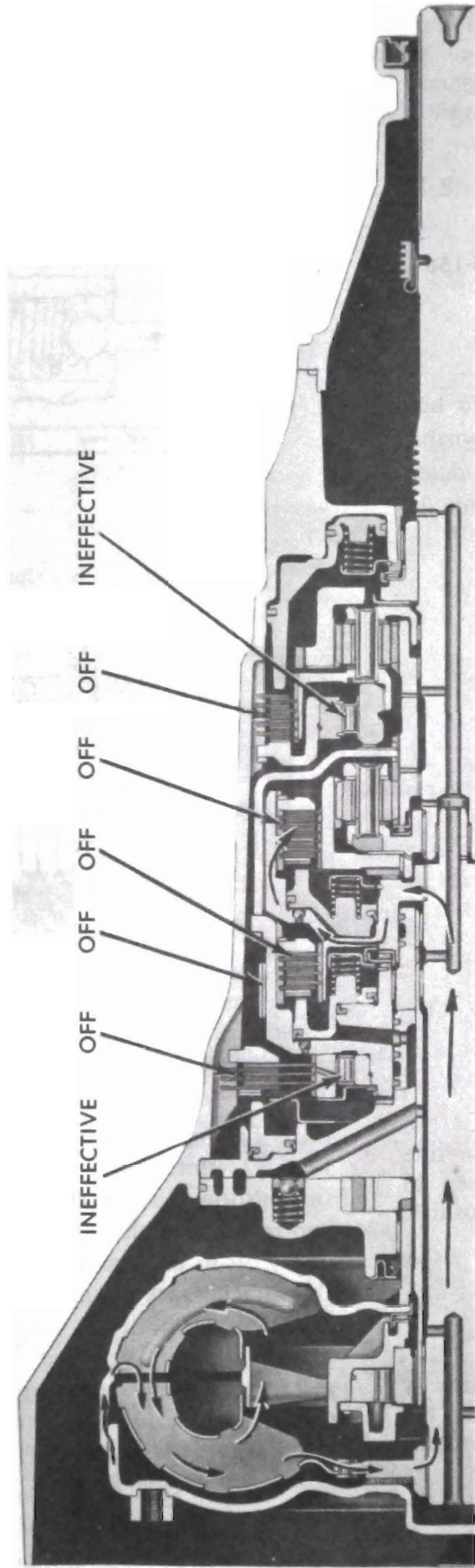

Intermediate Clutch - OFF

Direct Clutch - OFF

Forward Clutch - OFF

Low & Reverse Clutch - OFF

Intermediate Overrun Roller Clutch - INEFFECTIVE

Low and Reverse Roller Clutch - INEFFECTIVE

Intermediate Overrun Band - OFF

In park and neutral, all clutches and the intermediate overrun band are released; therefore no power is transmitted from the torque converter turbine to planetary gear sets or output shaft.

Figure 75-28 · Operation of Components in Park (P) or in Neutral (N)

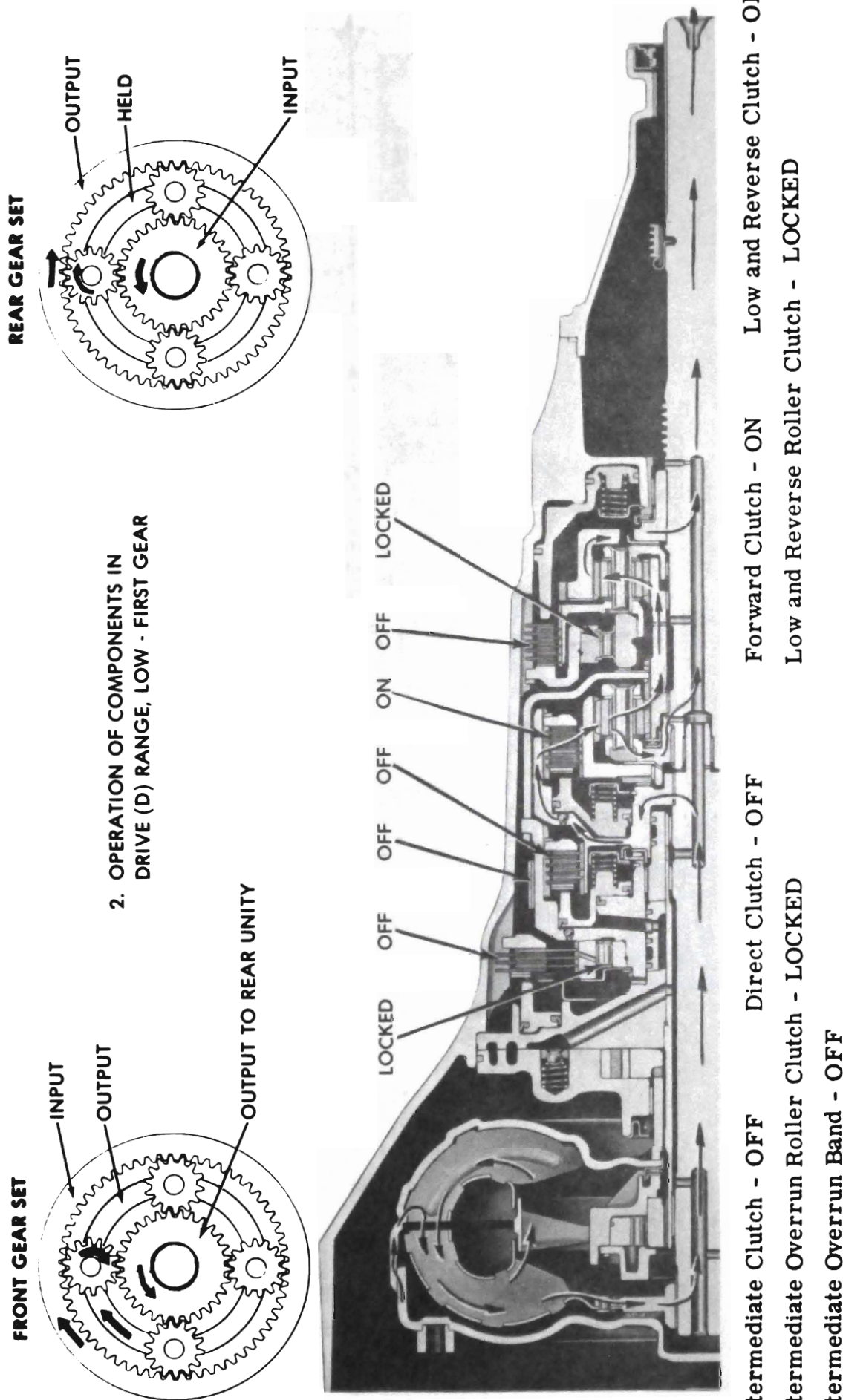

2. OPERATION OF COMPONENTS IN DRIVE (D) RANGE, LOW - FIRST GEAR

With the range selector lever in Drive "D" range, the forward clutch is applied. This delivers turbine torque from the input shaft through the forward clutch, to the input ring gear in a clockwise direction. (Converter torque ratio equals approximately 2:25 at stall)

Clockwise rotation of the input ring gear causes the output planet pinions to rotate in a clockwise direction, driving the sun gear counterclockwise. In turn, the sun gear turns the reaction carrier planet pinions to turn clockwise. Clockwise rotation of the reaction carrier planet pinions causes the output ring gear and output shaft to turn in a clockwise direction in a reduction ratio of approximately 2.52 to 1. The reaction of the reaction carrier planet pinions against the output ring gear is taken by the low and reverse roller clutch which is grounded to the case.

To prepare the transmission for the shift into intermediate (Second gear) the intermediate roller clutch is locked. Therefore, the sun gear, sun gear drive shell, direct clutch housing, intermediate roller clutch and the intermediate clutch faced plates are all turning in a counterclockwise direction.

Figure 75-29 · Operation of Components in Drive (D) Range, Low - First Gear



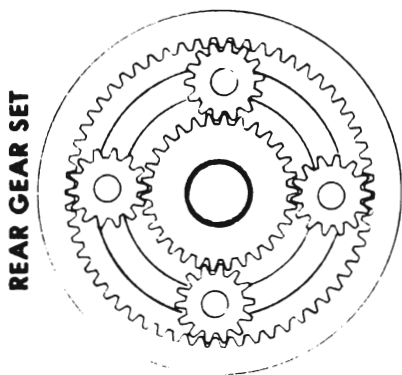

**3. OPERATION OF COMPONENTS IN DRIVE (D) RANGE, INTERMEDIATE SECOND GEAR**

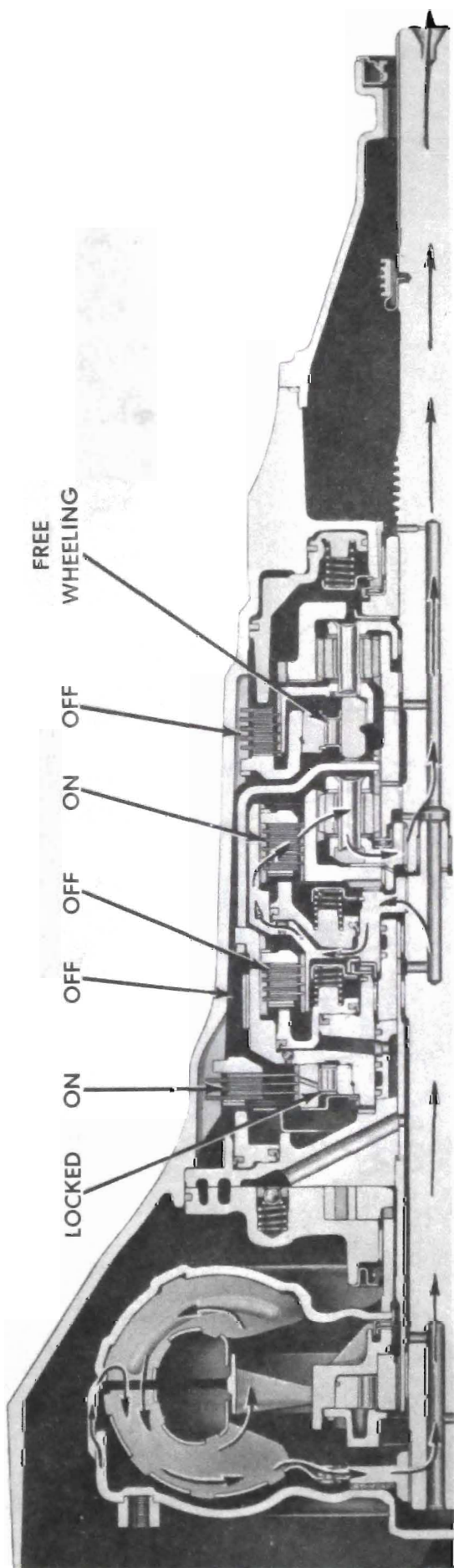
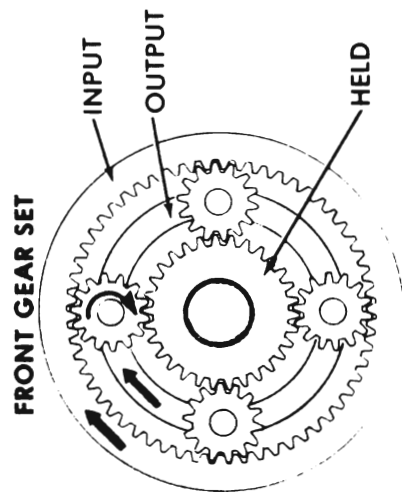

- Intermediate Clutch - ON    Direct Clutch - OFF    Forward Clutch - ON    Low and Reverse Clutch - OFF
- Intermediate Overrun Roller Clutch - LOCKED    Low and Reverse Roller Clutch - FREEWHEELING
- Intermediate Overrun Band - OFF

In Drive "D" range intermediate, (second gear) the intermediate clutch is applied to allow the intermediate overrun roller clutch to hold the shell and sun gear stationary (against counterclockwise rotation.) Turbine torque, through the applied forward clutch is delivered to the input ring gear in a clockwise direction. Clockwise rotation of the input ring gear causes the output planet pinions to walk around the stationary sun gear in a clockwise direction. This causes the output shaft to turn in a clockwise direction in a reduction ratio of approximately 1.52 to 1.

Figure 75-30 · Operation of Components in Drive (D) Range, Intermediate · Second Gear

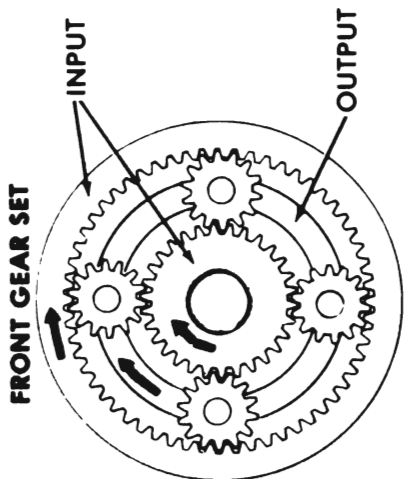
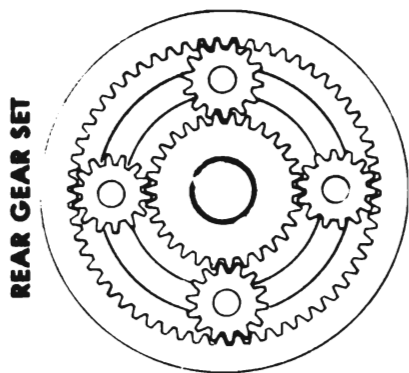

4. OPERATION OF COMPONENTS IN DRIVE (D) RANGE, DIRECT (THIRD GEAR)

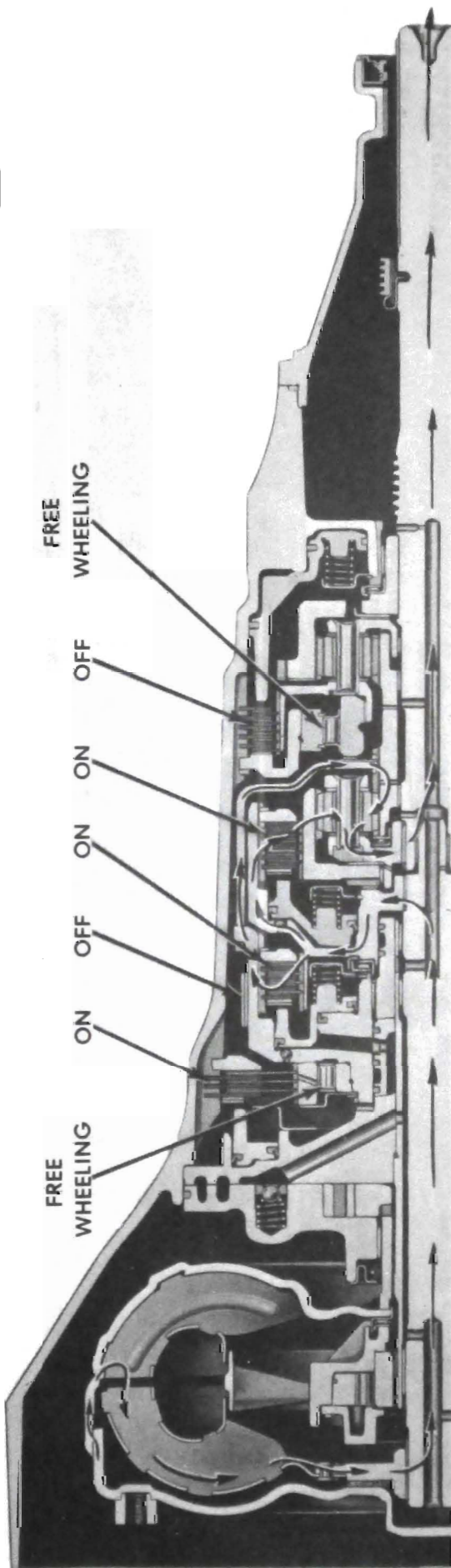

- Intermediate Clutch - ON      Direct Clutch - ON      Forward Clutch - ON      Low and Reverse Clutch - OFF
- Intermediate Overrun Roller Clutch - FREE WHEELING      Low and Reverse Roller Clutch - FREE WHEELING
- Intermediate Overrun Band - OFF

In direct drive, engine torque is transmitted to the converter then through the forward clutch, to the input ring gear in clockwise direction the direct clutch is applied transmitting torque through the sun gear drive shell to the sun gear in a clockwise direction. Since both the sun gear and the planet pinion gears are both turning in a clockwise direction at the same speed, the planetary gear sets are locked and turn as one unit in direct drive or at a ratio of 1:1.

Figure 75-31 - Operation of Components in Drive (D) Range, Direct - Third Gear



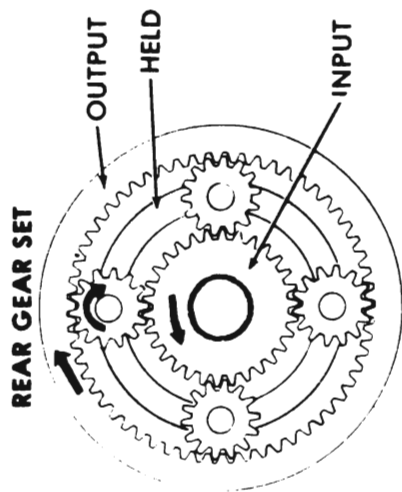

5 OPERATION OF COMPONENTS IN LOW (L<sub>1</sub>) RANGE, MANUAL FIRST GEAR

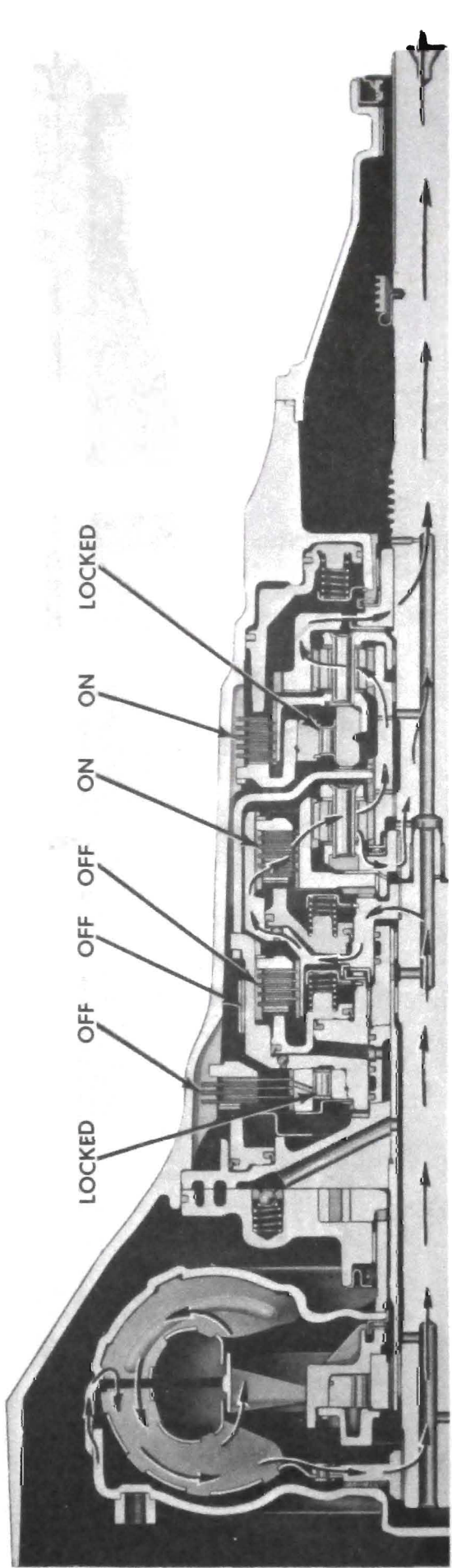
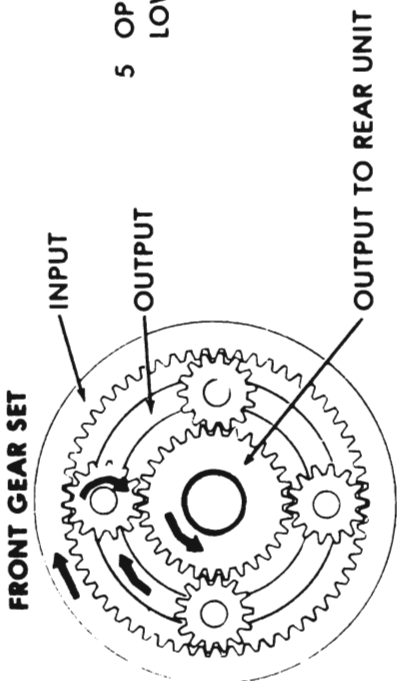

- Intermediate Clutch - OFF      Direct Clutch - OFF      Forward Clutch - ON      Low and Reverse Clutch - ON
- Intermediate Overrun Roller Clutch - Locked      Low and Reverse Roller Clutch - LOCKED
- Intermediate Overrun Band - OFF

With the range selector lever in L<sub>1</sub> range, the forward clutch is applied. This delivers turbine torque from the input shaft through the forward clutch, to the input ring gear in clockwise direction. (Converter torque ratio equals approximately 2:25 at stall.)

Clockwise rotation of the input ring gear causes the output planet pinions to rotate in a clockwise direction, driving the sun gear counterwise. In turn, the sun gear turns, causing the reaction carrier planet pinions to turn clockwise. Clockwise rotation of the reaction carrier planet pinions causes the output ring gear and output shaft to turn in a clockwise direction in a reduction ratio of approximately 2:52 to 1. The reaction of the reaction carrier planet pinions against the output ring gear is taken by either the low and reverse roller clutch or the low & reverse clutch which are grounded to the case.

When the transmission is shifted into L<sub>1</sub> (first gear), the low and reverse clutch is applied below a preset controlled car speed in addition to the forward clutch which is on for all forward ranges. The low and reverse clutch provides overrun braking as it holds the reaction carrier fixed.

Figure 75-32 - Operation of Components in Low (L<sub>1</sub>) Range - Manual First Gear

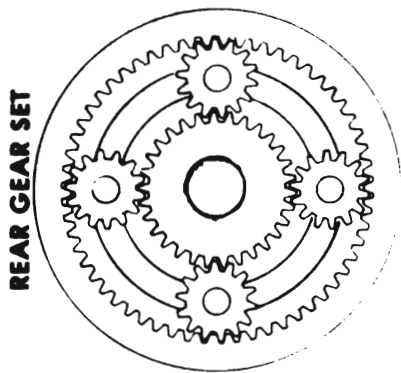

OPERATION OF COMPONENTS IN LOW (L<sub>2</sub>) RANGE, MANUAL SECOND GEAR

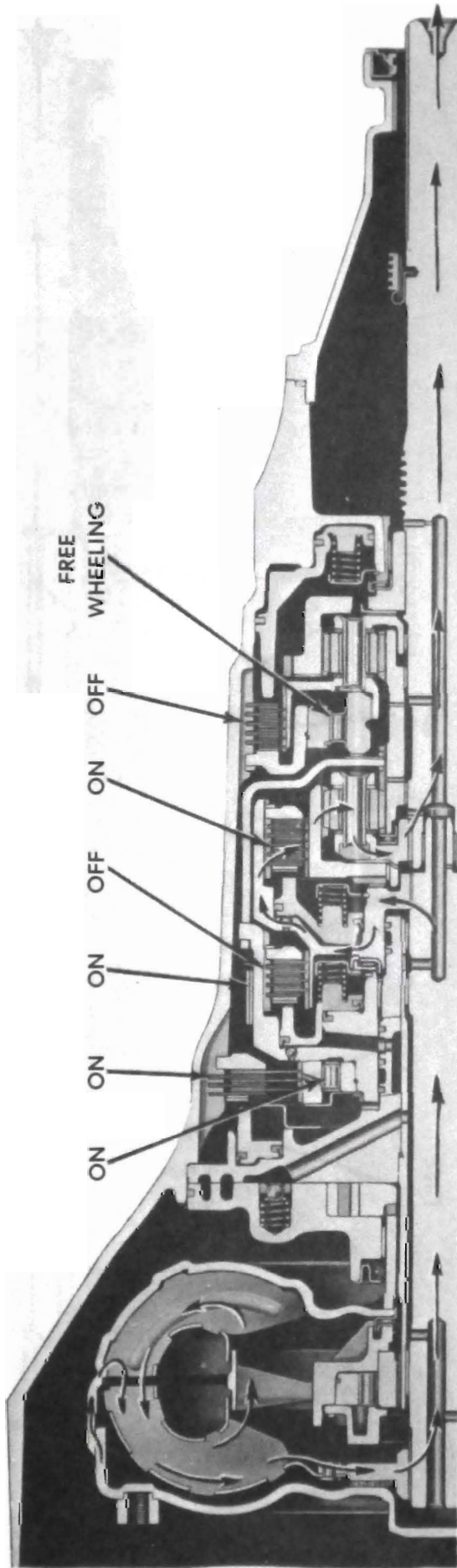
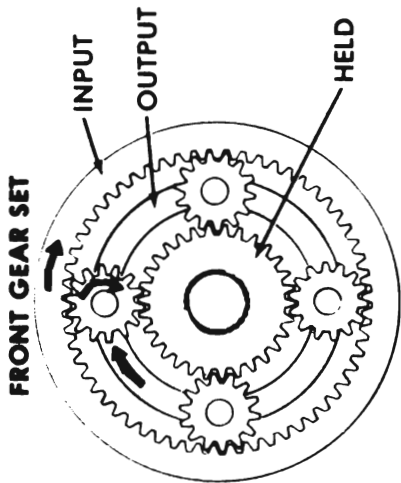

- Intermediate Clutch - ON
- Intermediate Overrun Roller Clutch - ON
- Intermediate Overrun Band - ON
- Direct Clutch - OFF
- Forward Clutch - ON
- Low and Reverse Clutch - OFF
- Low and Reverse Roller Clutch - FREE WHEELING

In L<sub>2</sub> range intermediate, the intermediate clutch is applied to allow the intermediate overrun roller clutch to hold the shell and sun gear stationary (against counterclockwise rotation). Turbine torque, through the applied forward clutch is delivered to the input ring gear in a clockwise direction. Clockwise rotation of the input ring gear causes the output planet pinions to walk around the stationary sun gear in a clockwise direction. This causes the output ring gear and output shaft to turn in a clockwise direction in a reduction ratio of approximately 1:52 to 1. The reaction of the output planet pinions against the sun gear is taken by either the intermediate overrun roller clutch or the intermediate overrun band. When the transmission is shifted into L<sub>2</sub> (second gear), the intermediate overrun band is applied in addition to the forward and intermediate clutches. The intermediate overrun band provides overrun braking as it holds the sun gear fixed.

Figure 75-33 - Operation of Components in Low (L<sub>2</sub>) Range - Manual Second Gear



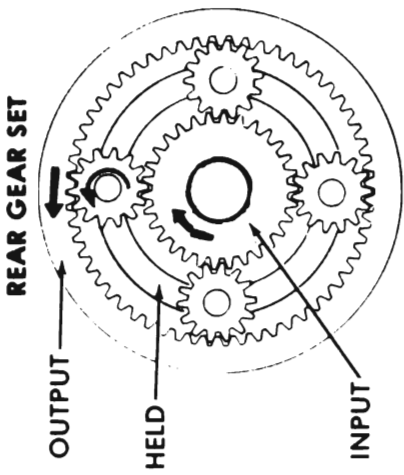

7. OPERATION OF COMPONENTS IN REVERSE (R) RANGE

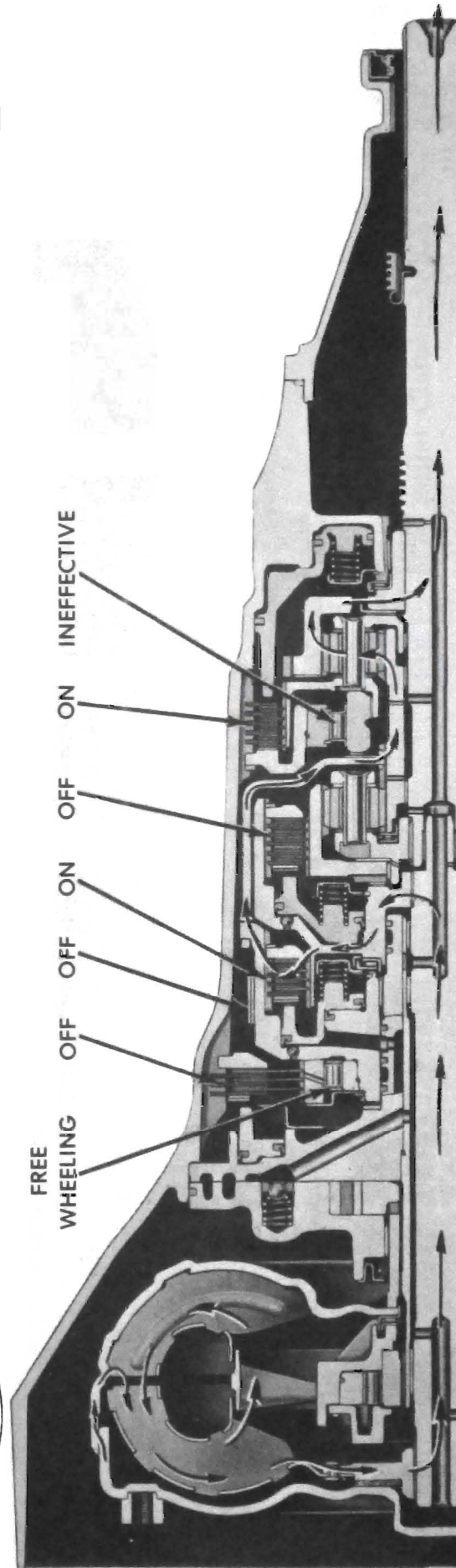
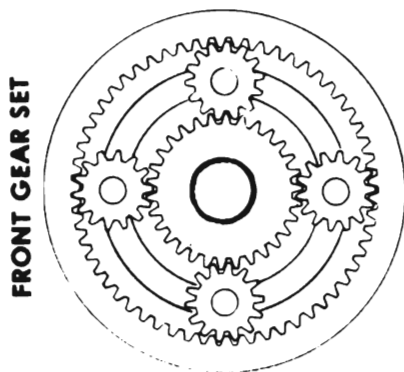

- Intermediate Clutch - OFF      Direct Clutch - ON      Forward Clutch - OFF      Low & Reverse Clutch - ON
- Intermediate Overrun Roller Clutch - FREE WHEELING      Low and Reverse Roller Clutch - INEFFECTIVE
- Intermediate Overrun Band - OFF

In Reverse "R", the direct clutch is applied to transmit torque from the forward clutch housing to the sun gear drive shell and the sun gear. The low and reverse clutch is applied preventing the output carrier from turning. Clockwise rotation of the sun gear causes the reaction carrier pinions to turn counterclockwise, thus turning the output ring gear and output shaft counterclockwise in a reduction ratio of approximately 1.93 to 1.

Figure 75-34 - Operation of Components in Reverse (R) Range



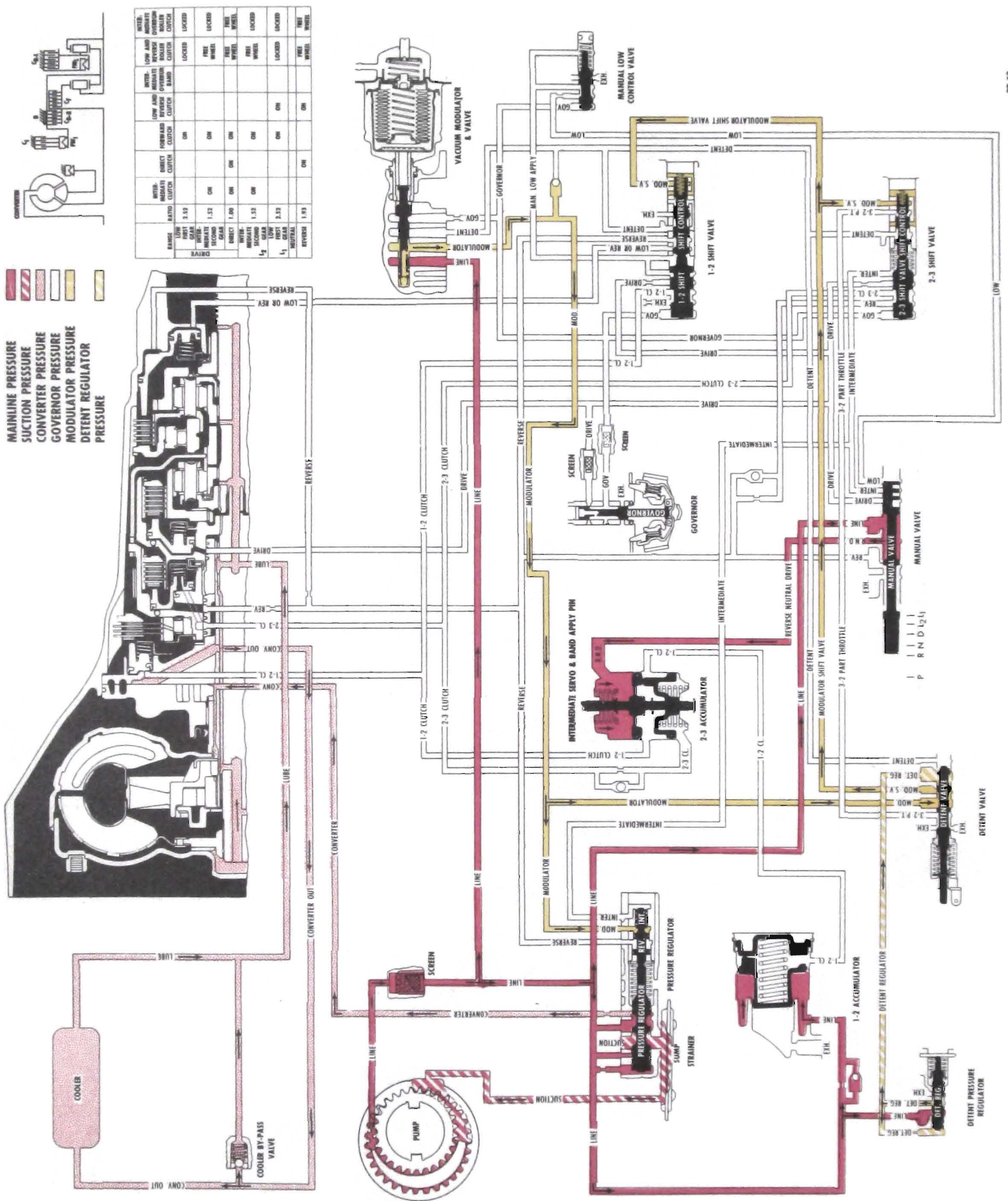

Figure 75-35 - Neutral - Engine Running

## 75-10

**NEUTRAL — ENGINE RUNNING**

Intermediate Clutch — Off  
 Direct Clutch — Off  
 Forward Clutch — Off  
 Low and Reverse Clutch — Off

Intermediate Overrun Roller Clutch — Free Wheeling  
 Low and Reverse Roller Clutch — Free Wheeling  
 Intermediate Overrun Band — Off

Whenever the engine is running at idle with the selector lever in neutral, oil from the pump is directed to —

1. Pressure Regulator Valve
2. Converter (With Pressure Regulator Valve Regulating)
  - a. Cooler By-pass Valve
  - b. Oil Cooler
  - c. Lubrication System
3. Manual Valve
4. Modulator Valve
5. 2-3 Accumulator (Neutral — Not in Park)
6. Detent Pressure Regulator
7. 1-2 Accumulator

fed directly from the converter to the lubrication circuit if the cooler should become restricted.

From the pressure regulator valve line oil is then routed as follows —

1. Manual Valve
2. 2-3 Accumulator
3. Detent Pressure Regulator
4. 1-2 Accumulator
5. Vacuum Modulator Valve

**Cooling and Lubrication**

Oil flows from the pump to the pressure regulator valve which regulates the pump pressure. When pump output exceeds the demand of line pressure, oil from the pressure regulator valve is directed to the converter feed passage to fill the converter. Converter return oil is directed to the cooler by pass valve and transmission cooler. Oil from the cooler is directed to the transmission lubrication system. The cooler by-pass valve permits oil to be

Line pressure at the modulator valve is regulated to modulator oil which acts on the modulator and reverse boost valve, detent valve, 2-3 shift control valve, and the 1-2 shift control valve.

**Summary**

The converter is filled, all clutches and bands are released. The transmission is in neutral.

75-13

Figure 75-36 - Neutral - Engine Running





**DRIVE RANGE — LOW — (FIRST GEAR)**

Intermediate Clutch — Off  
 Direct Clutch — Off  
 Forward Clutch — On  
 Low and Reverse Clutch — Off

Intermediate Overrun Roller Clutch — Locked  
 Low and Reverse Roller Clutch — Locked  
 Intermediate Overrun Band — Off

Line pressure is fed to the:

1. Modulator Valve
2. 1-2 Accumulator Piston
3. Detent Pressure Regulator Valve
4. Manual Valve

From the manual control valve line pressure forms drive oil and is fed to the:

1. Forward Clutch
2. Governor
3. 1-2 Shift Valve
4. 2-3 Shift Valve
5. Intermediate Servo (as R.N.D. oil)

**Basic Control**

When the selector lever is moved to the drive position, the manual valve directs line pressure to the R.N.D. and drive ports. R.N.D. pressure strokes the 2-3 accumulator so that it is prepared to cushion the 2-3 clutch for an upshift. The 1-2 accumulator has already been stroked with line oil to prepare it to cushion the 1-2 clutch.

Drive oil applies the forward clutch, feeds the governor and also the 1-2 and 2-3 shift valves.

**Summary**

Drive oil is directed to the forward clutch and is regulated to a variable pressure called governor pressure at the governor assembly.

Governor pressure increases with car speed and acts against the ends of the 1-2 and 2-3 shift valves, and the modulator valve.

75-15

Figure 75-38 - Drive Range - Low (First Gear)

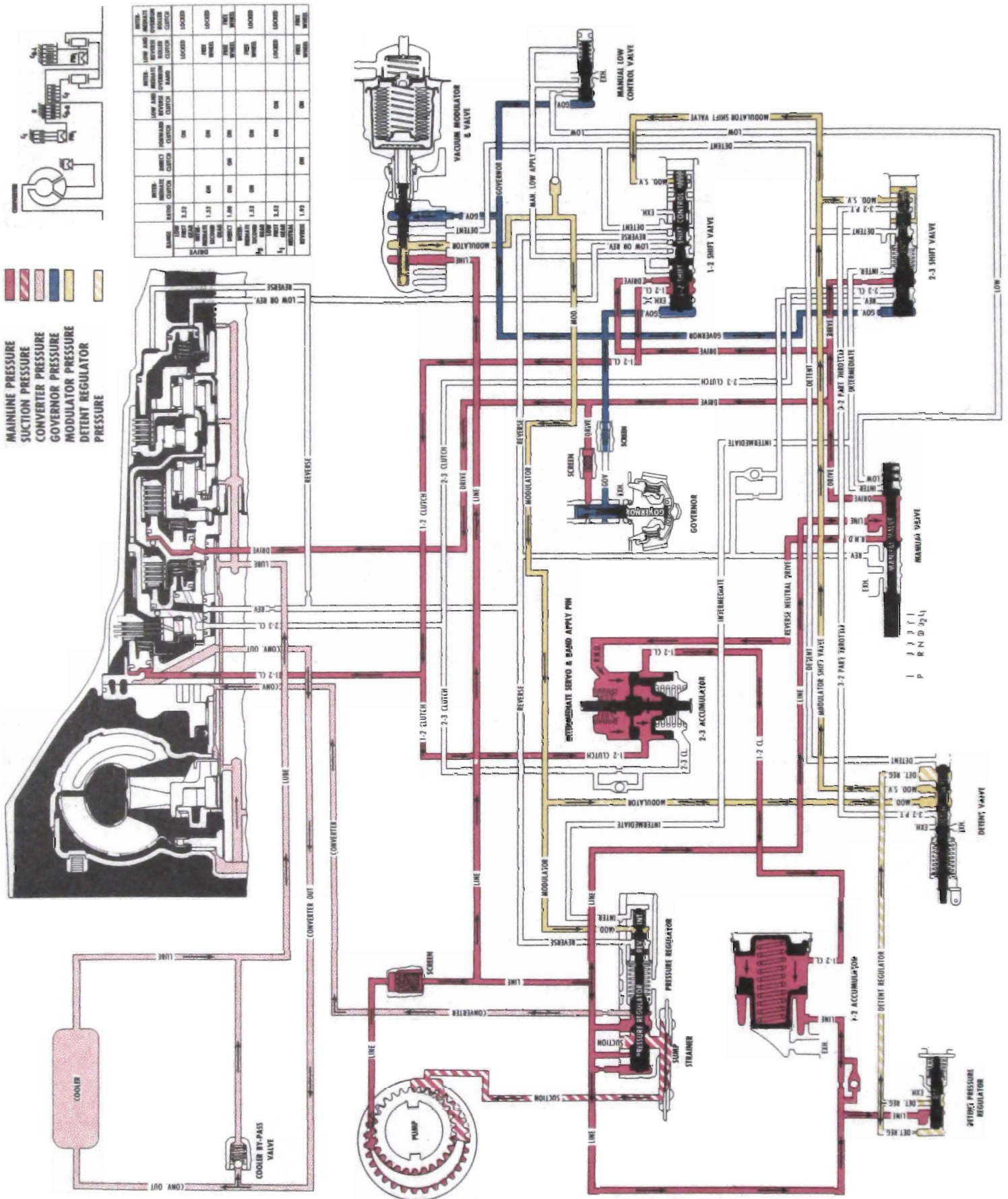

Figure 75-39 - Drive Range - Intermediate (Second Gear)



**DRIVE RANGE — INTERMEDIATE (SECOND GEAR)**

Intermediate Clutch — On  
 Direct Clutch — Off  
 Forward Clutch — On  
 Low and Reverse Clutch — Off

Intermediate Overrun Roller Clutch — Locked  
 Low and Reverse Roller Clutch — Free Wheeling  
 Intermediate Overrun Band — Off

F

As both vehicle speed and governor pressure increase, the force of governor pressure (46 PSI @ W.O.T.) acting on the 1-2 shift valve overcome the force of the 1-2 shift valve spring and modulator oil regulated by the modulator valve. This allows the 1-2 shift valve to move to the upshifted position which directs drive oil to apply the intermediate clutch. Oil in this passage is called (1-2) clutch oil.

**Basic Control**

Intermediate clutch oil flows from the 1-2 shift valve through the 2-3 accumulator. And then to the 1-2 accumulator which cushions intermediate clutch application. The 1-2 accumulator has clutch apply pressure and a calibration spring acting on one side with line pressure on the other side.

Intermediate (1-2) clutch oil from the 1-2 shift valve is directed to:

1. Intermediate Clutch
2. 2-3 Accumulator
3. 1-2 Accumulator

**Summary**

The forward and intermediate clutch are applied. The transmission is in drive range 2nd gear. When in drive range the full throttle 1-2 upshift will occur at approximately 42-49 MPH and minimum throttle 1-2 upshift will occur at approximately 9-12 MPH.

Figure 75-40 · Drive Range · Intermediate (Second Gear)





**DRIVE RANGE — DIRECT (THIRD GEAR)**

Intermediate Clutch — On  
 Direct Clutch — On  
 Forward Clutch — On  
 Low and Reverse Clutch — Off

Intermediate Overrun Roller Clutch — Free Wheeling  
 Low and Reverse Roller Clutch — Free Wheeling  
 Intermediate Overrun Band — Off

As vehicle speed and governor pressure increase, the force of the governor pressure (77 PSI @ W.O.T.) acting on the 2-3 shift valve overcomes the force of the 2-3 shift valve spring and modulator oil. This allows the 2-3 shift valve to move to the upshifted position feeding drive oil to the direct clutch. This oil is called 2-3 (direct) clutch oil.

**Basic Control**

Direct (2-3) clutch oil from the 2-3 shift valve flows to the direct clutch and also to the 2-3 accumulator piston. The shift is cushioned by the R.N.D. oil force on the other side of the accumulator piston.

**Summary**

The forward, intermediate and direct clutches are applied. The transmission is in drive range — third gear (direct drive).  
 When in drive range the full throttle 2-3 upshift will occur at approximately 70-79 MPH and minimum throttle 2-3 upshifts will occur at approximately 20 MPH.

Direct (2-3) clutch oil is directed from the 2-3 shift valve to:

1. Direct Clutch
2. 2-3 Accumulator

Figure 75-42 · Drive Range · Direct (Third Gear)

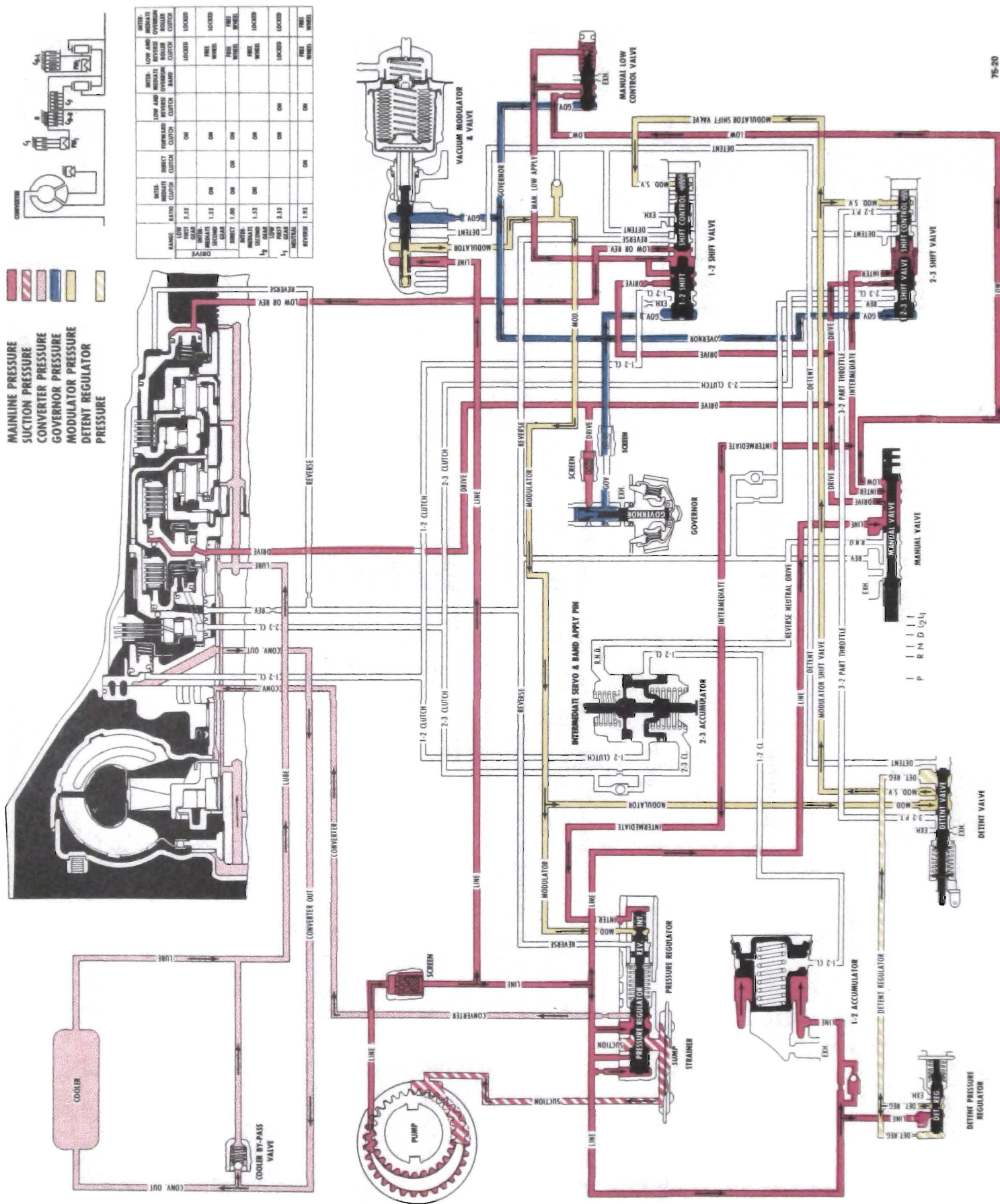

Figure 75-43 · L1 Range (Manual Low - 1st Gear)



**L<sub>1</sub> — RANGE (MANUAL LOW — FIRST GEAR)**

Intermediate Clutch — Off  
 Direct Clutch — Off  
 Forward Clutch — On  
 Low and Reverse Clutch — On

Intermediate Overrun Roller Clutch — Locked  
 Low and Reverse Roller Clutch — Locked  
 Intermediate Overrun Band — Off

Maximum downhill braking can be attained at speeds below approximately 42 MPH with the selector lever in L<sub>1</sub> range position, low range oil from the manual valve is then directed to the manual low control valve which in turn directs it through the 1-2 shift valve train to the low and reverse clutch piston (inner area only).

which engages this clutch. Once the manual low control valve is in the downshifted position, its spring plus low apply oil acting on it will keep it in this position; therefore, with the transmission in manual low (L<sub>1</sub> range), the transmission cannot upshift to intermediate (second gear) regardless of vehicle or engine speed once low gear has been engaged.

**Basic Control**

The manual low control valve is positioned to exhaust the manual low apply line when the manual valve is placed in the manual low (L<sub>1</sub>) position above approximately 42 MPH. At speeds below 42 MPH low oil is fed into the manual low apply line which moves the 1-2 shift valve to the downshift position (exhausting the 1-2 clutch) and moves the 1-2 shift control valve to the upshifted position which sends low apply oil to the low and reverse clutch

**Summary**

The forward clutch and the low and reverse clutch are applied. The transmission is in low (first gear) L<sub>1</sub> range. The manual low control valve is used also to protect the engine by preventing low range engagement (indicated by high car speed which is sensed by high governor pressure) at car speeds over 42 MPH, or approximately 3600 engine rpm.



**L<sub>2</sub> — INTERMEDIATE RANGE (MANUAL SECOND GEAR)**

Intermediate Clutch — On  
 Direct Clutch — Off  
 Forward Clutch — On  
 Low and Reverse Clutch — Off

Intermediate Overrun Roller Clutch — Locked  
 Low and Reverse Roller Clutch — Free Wheeling  
 Intermediate Overrun Band — On

A manual 3-2 downshift can be accomplished by moving the selector lever from drive to intermediate range (L<sub>2</sub>). Intermediate oil from the manual valve is then directed to:

1. Intermediate Boost Valve
2. 2-3 Shift Valve

Intermediate oil at the pressure regulator intermediate boost valve will increase minimum line pressure to 80 PSI. Intermediate oil will move the 2-3 shift valve to the downshifted position regardless of car speed. This in turn releases the direct clutch.

When the manual valve is moved to the intermediate position R.N.D. oil is

exhausted. 1-2 clutch oil acting on the intermediate servo piston then applies the intermediate overrun band which places the transmission in second gear. This provides engine braking in the intermediate range by preventing counterclockwise rotation of the direct clutch drum, sun gear drive shell, and sun gear once the transmission is in second gear, it cannot upshift to third gear regardless of car speed.

**Summary**

When the forward, intermediate clutches and intermediate overrun band are applied, the transmission is in intermediate range — second gear and allows engine braking. When the car slows down to approximately 9 MPH a 2-1 shift will occur when decreased governor pressure allows the 1-2 shift valve to move and exhaust the 1-2 clutch.

Figure 75-46 - L<sub>2</sub> Intermediate Range (Manual Second Gear)





**DRIVE RANGE DETENT DOWNSHIFT (1-2 AND 2-3 SHIFT VALVES IN SECOND GEAR POSITION)**

Intermediate Clutch — On  
 Direct Clutch — Off  
 Forward Clutch — On  
 Low and Reverse Clutch — Off

Intermediate Overrun Roller Clutch — Locked  
 Low and Reverse Roller Clutch — Free Wheeling  
 Intermediate Overrun Band — Off

While operating at speeds below approximately 65-75 MPH, a forced or detent 3-2 downshift is possible by depressing the accelerator fully. This moves the detent valve by cable linkage, to its extreme inner position allowing modulator oil to be routed into the 3-2 part throttle passage and detent regulator oil to be routed into the modulator shift valve and detent passages. Detent regulated oil therefore acts on both the 1-2 & 2-3 shift control valves and modulator pressure also acts on the 2-3 shift control valve through the 3-2 part throttle passage. Detent regulator oil is also routed to the modulator valve via the detent passage.

Modulator oil, detent regulator oil plus the force of the 2-3 shift control valve spring will move the 2-3 shift valve to the downshift position below approximately 65-75 MPH shifting the transmission to second gear.

A detent 2-1 or 3-1 downshift can also be accomplished below approximately 40 MPH because detent regulator oil is directed to 1-2 shift control valve.

This allows detent regulator oil plus the force of the 1-2 shift control valve spring to move the 1-2 shift valve to the downshifted position placing the transmission in first gear.

Detent regulator oil is directed to the modulator valve to prevent modulator pressure from falling below that of detent regulator at high speeds or at high altitudes.

**NOTE:** The 3-2 part throttle downshift can be made below 45 MPH (see insert of detent valve in part throttle position). At light throttle opening the 3-2 part throttle passage is exhausted; however, at moderate throttle opening the detent valve connects modulator pressure to the 3-2 part throttle passage. If modulator pressure acting on the 3-2 part throttle area of the 2-3 shift control valve plus the 2-3 shift valve spring is sufficient to move the valve to the downshifted position, the transmission will be in second gear.





**REVERSE**

Intermediate Clutch — Off  
 Direct Clutch — On  
 Forward Clutch — Off  
 Low and Reverse Clutch — On

Intermediate Roller Clutch — Free Wheeling  
 Low and Reverse Roller Clutch — Free Wheeling  
 Intermediate Overrun Band — Off

When the selector lever is moved to the reverse position, the manual valve is repositioned to allow line pressure to enter the reverse circuit. Reverse oil then flows as shown below.

1. Direct (2-3) Clutch.
2. Low and Reverse Clutch
3. 1-2 Shift Valve
4. 2-3 Shift Valve
5. Reverse Boost Valve

**Basic Control**

Reverse oil from the manual valve flows to the outer area of the direct clutch piston, to the outer area of the low and reverse clutch piston, to the 1-2 shift valve and to the 2-3 shift valve. From the 1-2 shift valve, it is directed to the inner area of the low and reverse clutch piston. From the 2-3 shift valve it is directed to the inner area of the direct clutch piston.

Reverse oil also acts on the reverse boost valve to increase line pressure to a maximum of **250 PSI** at stall.

**Summary**

The direct clutch and the low and reverse clutch are applied. Line pressure is boosted and the transmission is in reverse.

Figure 75-50 · Reverse

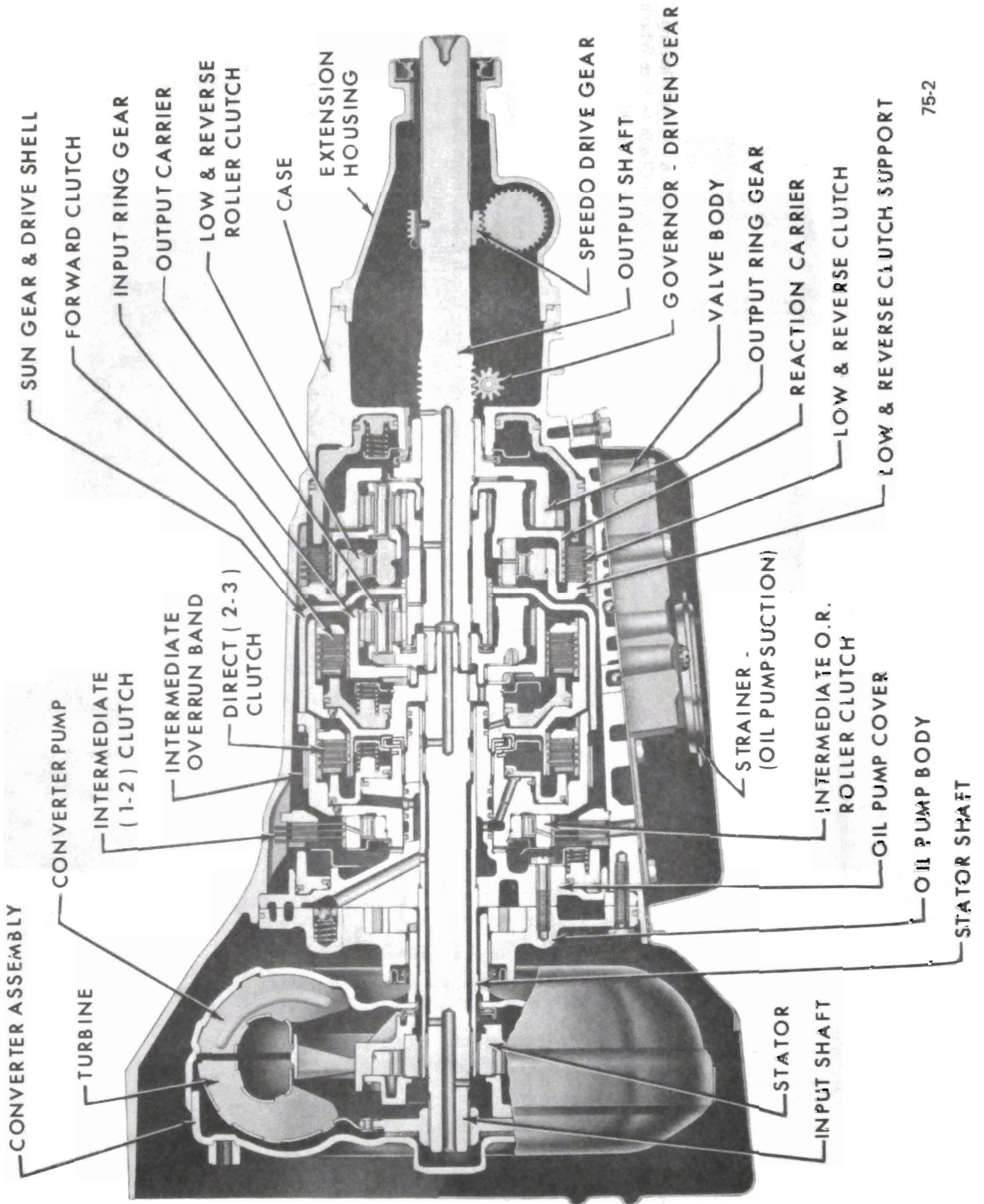

Figure 75-51



## DIVISION III

### ADJUSTMENTS AND MINOR SERVICE

#### 75-11 DETENT CABLE ADJUSTMENT

1. Position retainer on upper end of cable. See Figure 75-53, view B.

2. Attach cable to throttle bracket "C", being sure guide is fully seated.

3. With throttle cable connected to carburetor and throttle lever, depress accelerator pedal fully to adjust retainer.

- 1 SCREW
- 2 SEAL
- 3 CLIP
- 4 CABLE ASM (FITTING CODE - BLACK)
- 5 RETAINER
- 6 RETAINER
- 7 RETAINER

A APPLY OIL BEFORE ASSEMBLY

- ▲ 72-108 LB-IN
- ▲
- ▲
- ▲
- ▲

#### ADJUSTMENT OF TRANSMISSION DETENT

- 1 — INSTALL CABLE THRU THROTTLE LEVER HOLE. INSTALL RETAINER BEING SURE IT IS SEATED.
- 2 — POSITION RETAINER ON UPPER END OF CABLE PER VIEW "B".
- 3 — WITH THROTTLE CABLE CONNECTED TO CARBURETOR AND THROTTLE LEVER, FULLY DEPRESS ACCELERATOR PEDAL TO ADJUST RETAINER.

B CARE MUST BE TAKEN NOT TO BEND CABLES DURING INSTALLATION OF RETAINERS.

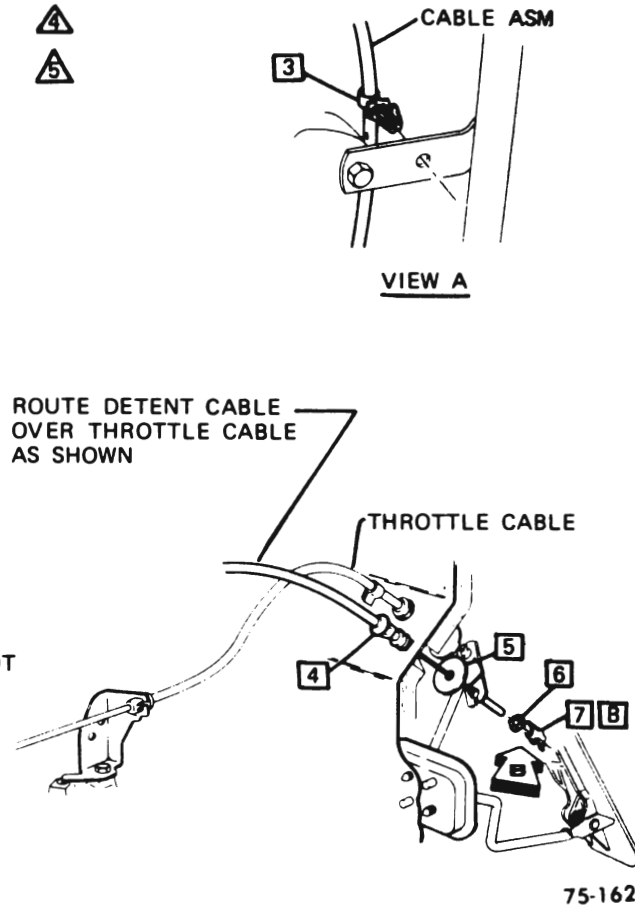
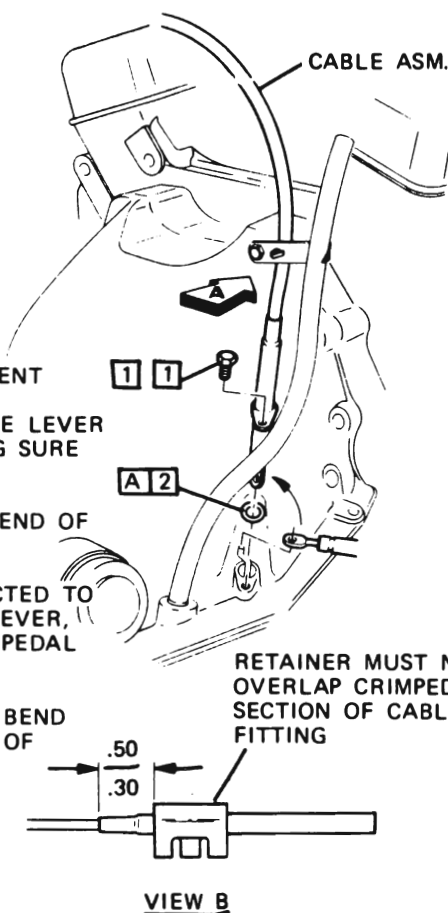

75-162F

Figure 75-53 - Transmission Detent Cable Adjustment

#### 75-12 REMOVAL OF PROPELLER SHAFT YOKE SEAL (375B ONLY), SPEEDOMETER DRIVE GEAR AND GOVERNOR

##### A. Removal of Propeller Shaft Yoke Seal (375B Only)

Remove propeller shaft yoke seal, using Tool J- 23103 and screwdriver. See Figure 75-54.

##### B. Removal of Speedometer Drive Gear

1. Depress speedometer drive gear retaining clip, then slide speedometer drive gear off output shaft. See Figure 75-55.

##### C. Removal of Governor

Note that when replacing governor of KL-375B Model transmission, part number for that particular model must be used.



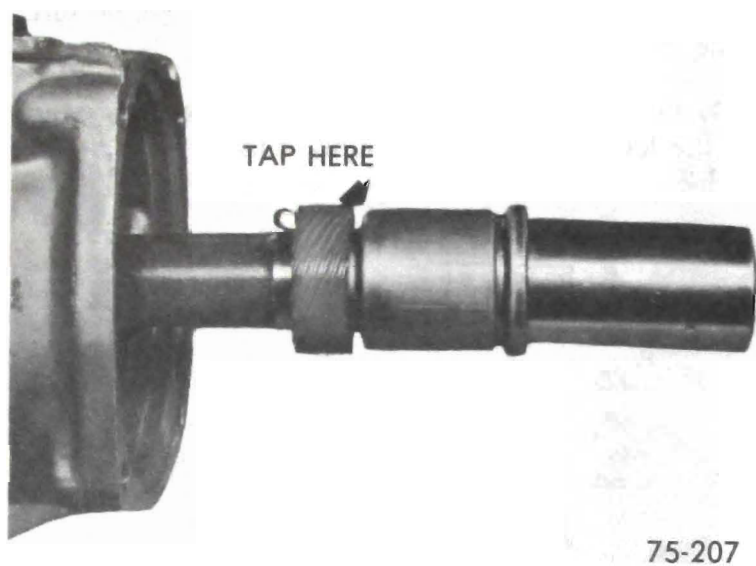

75-207

Figure 75-54 - 375B Transmission

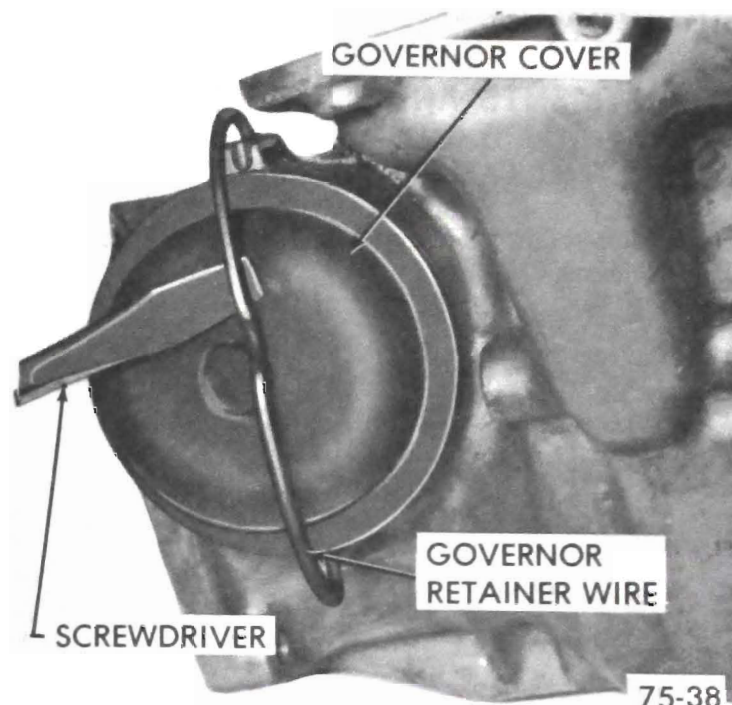

75-38

Figure 75-56

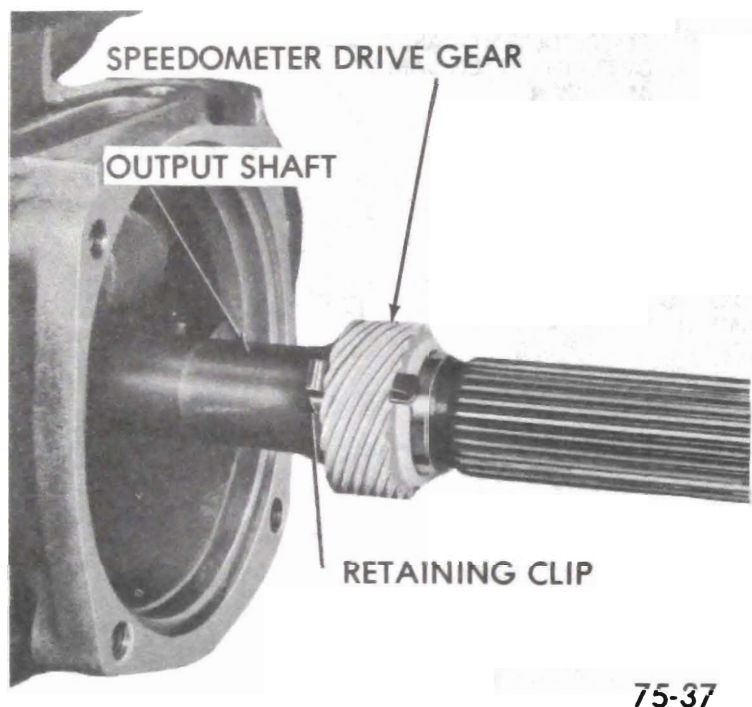

75-37

Figure 75-55

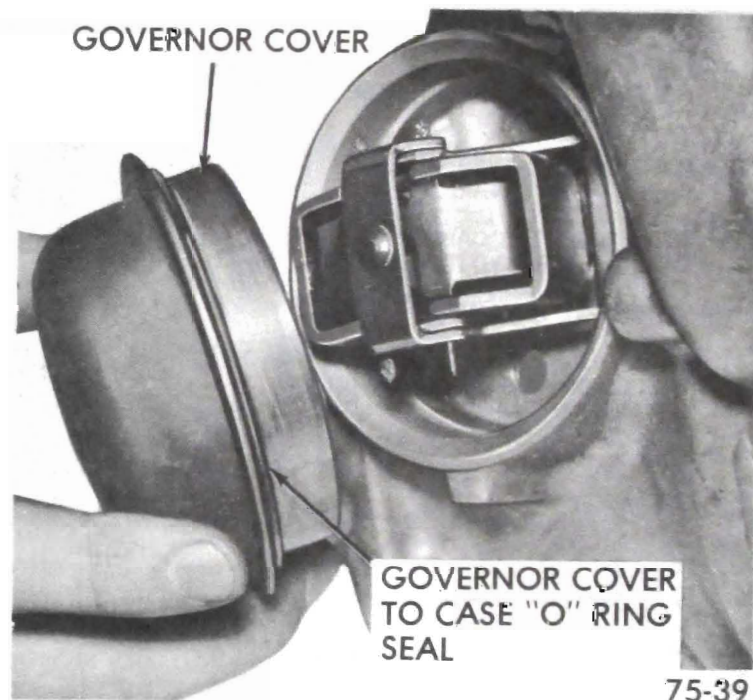

75-39

Figure 75-57

1. Remove governor cover retainer wire with a screwdriver. See Figure 75-56.

2. Remove governor cover and "O" ring seal from case. Aid removal of cover with screwdriver. Use extreme care not to damage cover. If cover is damaged it must be replaced.

Remove "O" ring seal from governor cover, and replace. See Figure 75-57.

3. Withdraw governor assembly from case. See Figure 75-58.

Check governor bore and governor sleeve for scoring.

When servicing the 1972 valve body spacer plate or gaskets, it should be noted that only 1971-72 service parts should be used as replacement parts. The spacer plate has a code letter "J" stamp on it for identification, and the gaskets have a yellow paint mark on one edge.

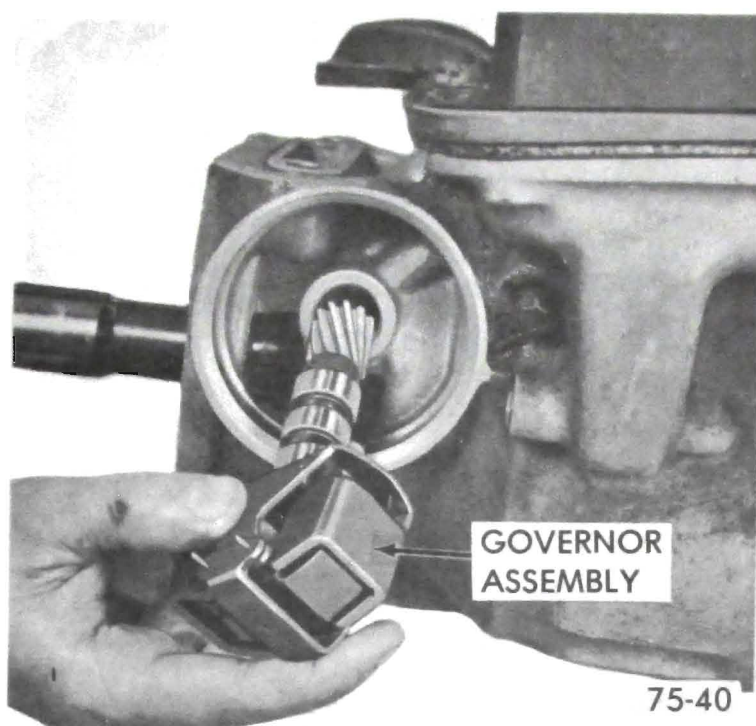

Figure 75-58

### 75-13 REMOVAL OF OIL PAN, OIL STRAINER, AND VALVE BODY

Removal of oil pan, oil strainer, and valve body can be done without removal of transmission from car, if valve body is removed while transmission is still in the car, be careful not to lose the four (4) plastic check balls when the space plate and gasket are lowered.

#### A. Removal of Oil Pan

1. Remove (13) oil pan attaching screw and washer assemblies, oil pan, and gasket. See Figure 75-59.

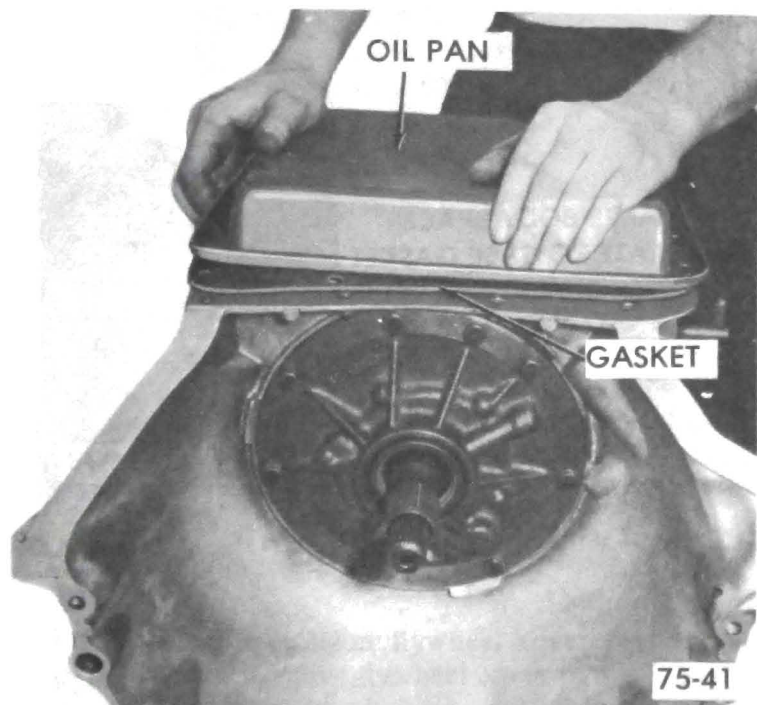

Figure 75-59

#### B. Removal of Oil Screen

1. Remove two (2) strainer assembly to valve body attaching screws. See Figure 75-60.

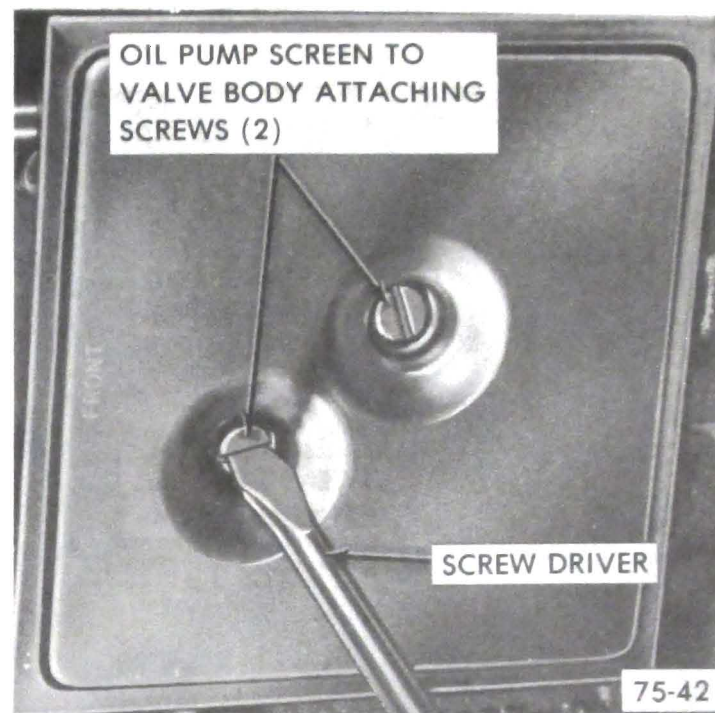

Figure 75-60

2. Remove strainer assembly and gasket from valve body. See Figure 75-61.

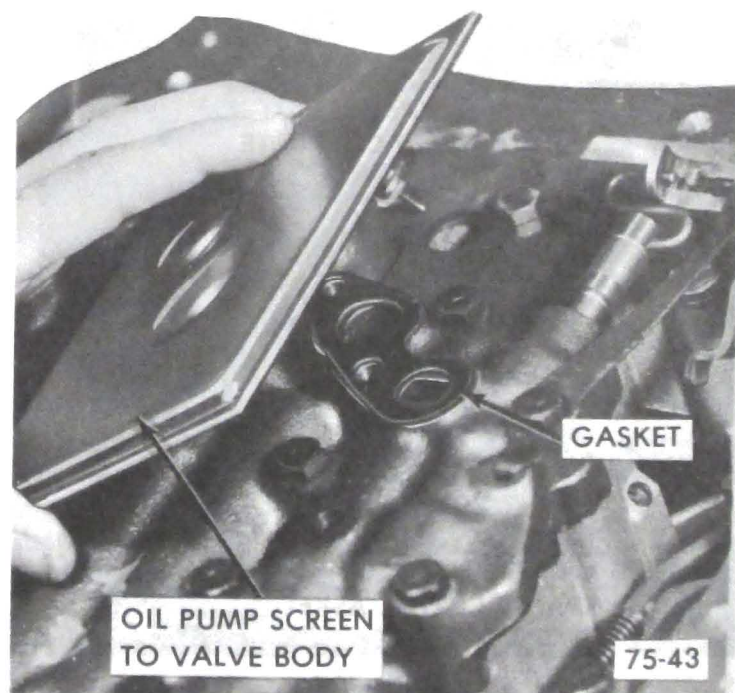

Figure 75-61

#### C. Removal of Valve Body

1. Remove detent roller and spring assembly from valve body. Remove valve body to case attaching bolts.



See Figure 75-62.

2. Remove valve body from case while carefully guiding manual valve link from range selector inner lever. Remove detent control valve link from detent actuating lever.

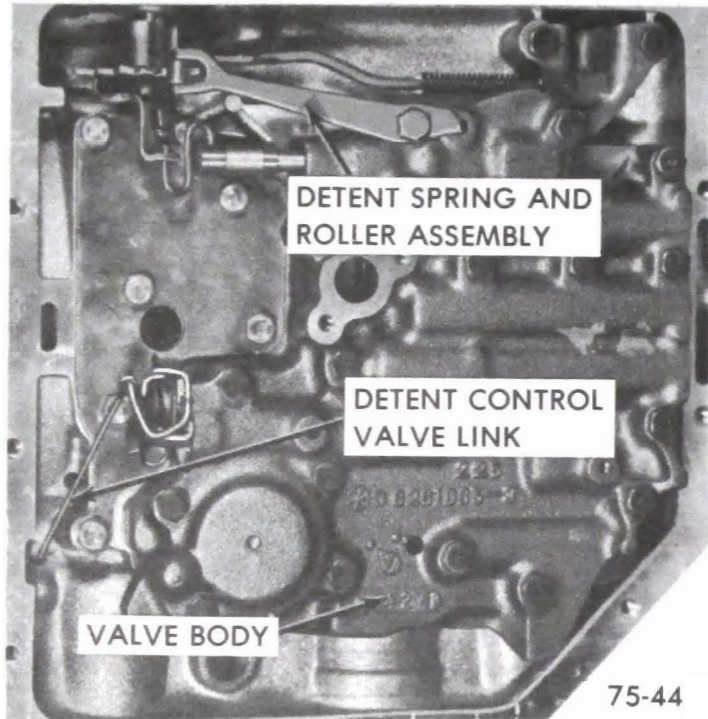

Figure 75-62

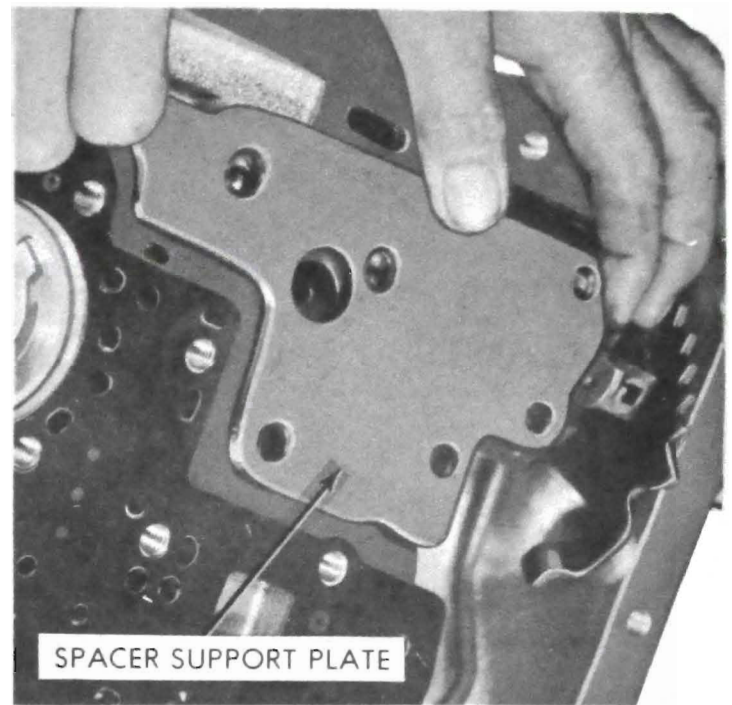

Figure 75-64

5. Remove valve body spacer plate and valve body spacer plate to case gasket. See Figure 75-65. Be sure to note position of the four (4) plastic check balls so they are assembled correctly.

3. Remove valve body to spacer plate gasket. See Figure 75-63.

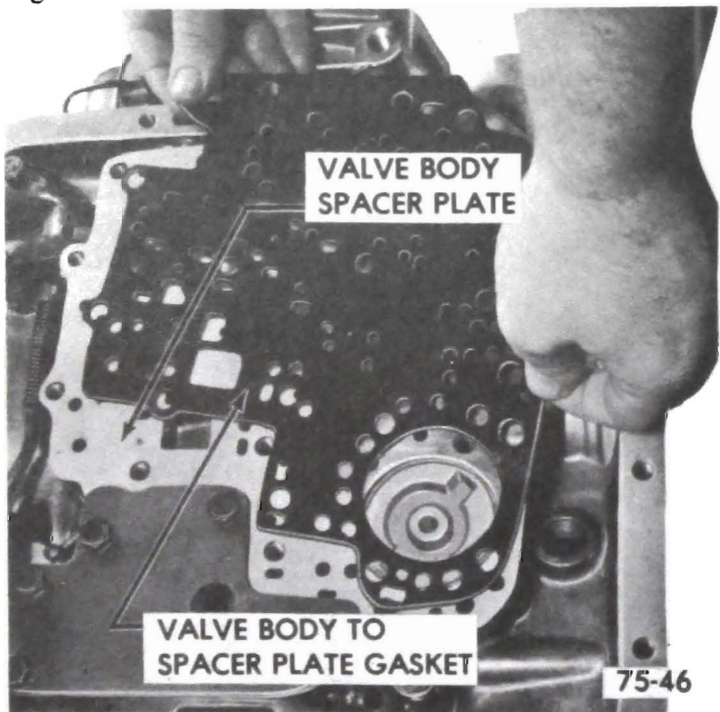

Figure 75-63

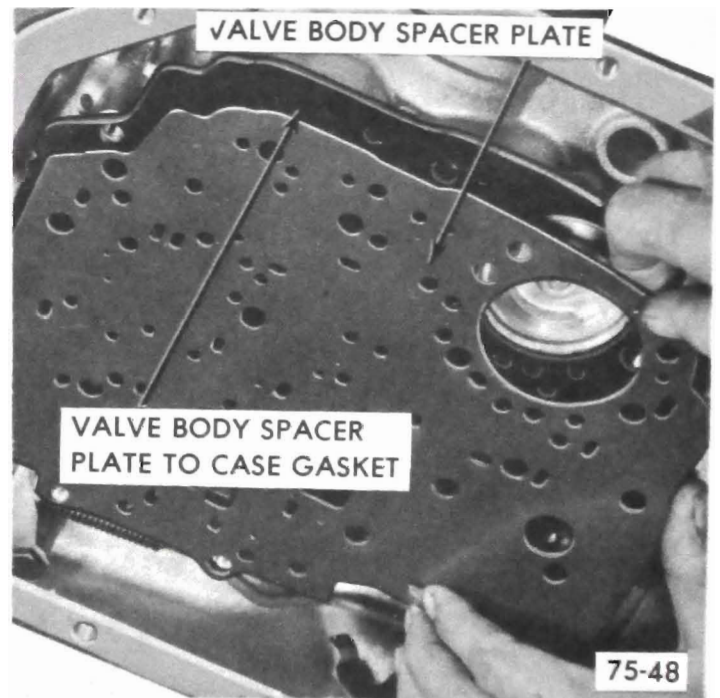

Figure 75-65

4. Remove spacer support plate bolts. Remove spacer support plate. See Figure 75-64.

## DIVISION IV

### REMOVAL AND INSTALLATION

#### 75-14 TRANSMISSION ASSEMBLY - REMOVAL AND INSTALLATION

##### A. Removal

1. Raise car and provide support for front and rear of car.
2. Disconnect front exhaust crossover pipe if necessary.
3. Remove propeller shaft.
4. Place suitable jack under transmission and fasten transmission securely to jack.
5. Remove vacuum line from vacuum modulator. See Figure 75-66.
6. Loosen cooler line nuts and separate cooler lines from transmission.

See Figure 75-67.

7. Remove detent cable from accelerator lever assembly.

*Do Not Bend Cable.* Remove plastic guide from bracket and slide cable out through slot. See Figure 75-53.

8. Remove detent cable from detent valve link. *Do Not Bend Cable.*

9. Remove transmission mounting pad to cross member bolts.

10. Remove transmission cross member support to frame rail bolts. Remove cross member.

11. Disconnect speedometer cable.

12. Disconnect shift linkage from transmission.

13. Disconnect transmission filler pipe at engine. Remove filler pipe from transmission. See Figure 75-66.

14. Support engine at oil pan.

15. Remove transmission flywheel cover pan to case tapping screws. Remove flywheel cover pan.

16. Mark flywheel and converter for reassembly in same position, and remove three converter to flywheel

bolts.

17. Assemble transmission to suitable transmission jack and remove transmission case to engine block bolts.

18. Move transmission rearward to provide clearance between converter pump and crankshaft. Install converter holding Tool J-21366 to retain converter. Lower transmission and move to bench.

##### B. Installation

1. Assemble transmission to suitable transmission jack and raise transmission into position. Remove converter holding Tool J-21366. Rotate converter to permit coupling of flywheel and converter with original relationship.

2. Install transmission case to engine block bolts. Torque to 30-40 lb.ft. Do not overtorque.

3. Install flywheel to converter bolts. Torque to 25-35 lb.ft.

4. Install transmission cross member support. Install mounting pad.

5. Remove transmission jack and engine support.

6. Install transmission flywheel cover pan with tapping screws.

7. Install transmission filler pipe using a new "O" ring. See Figure 75-66.

8. Reconnect speedometer cable.

9. Install propeller shaft.

10. Reinstall front exhaust crossover pipe, if removed.

11. Install detent cable on detent valve link. *Do Not Bend Cable.*

12. Install detent cable on accelerator lever assembly. *Do Not Bend Cable.*

Install cable by sliding through slot on bracket and snapping plastic guide back on the bracket. For adjustment refer to paragraph 75-11.

13. Install oil cooler lines to transmission. See Figure 75-67.

14. Install vacuum line to vacuum modulator. See Figure 75-66.

15. Fill transmission with fluid as described in Paragraph 75-36, Subparagraph d.





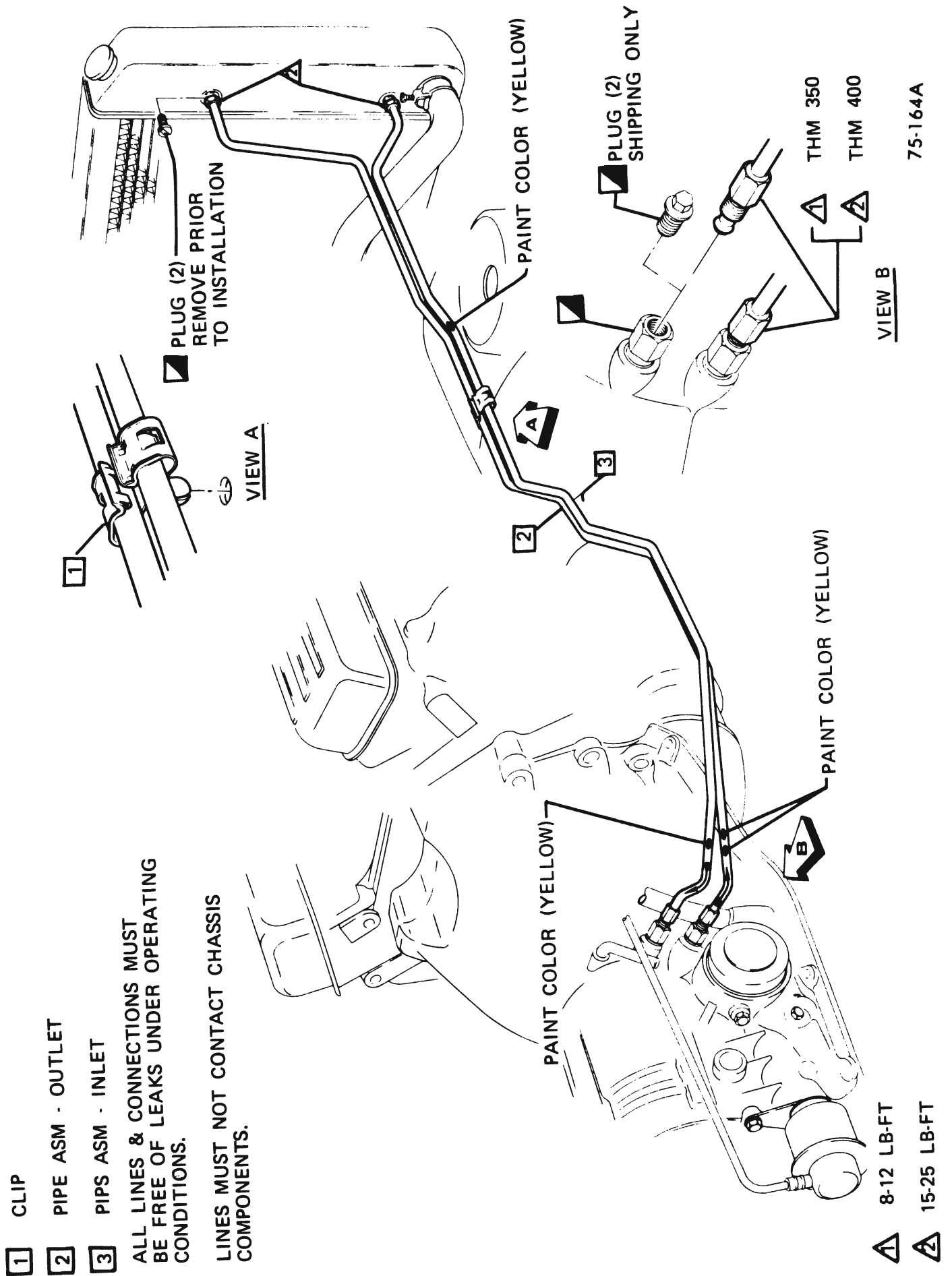

Figure 75-67 - Oil Cooler Lines (4D-4F-4G-4H Series)

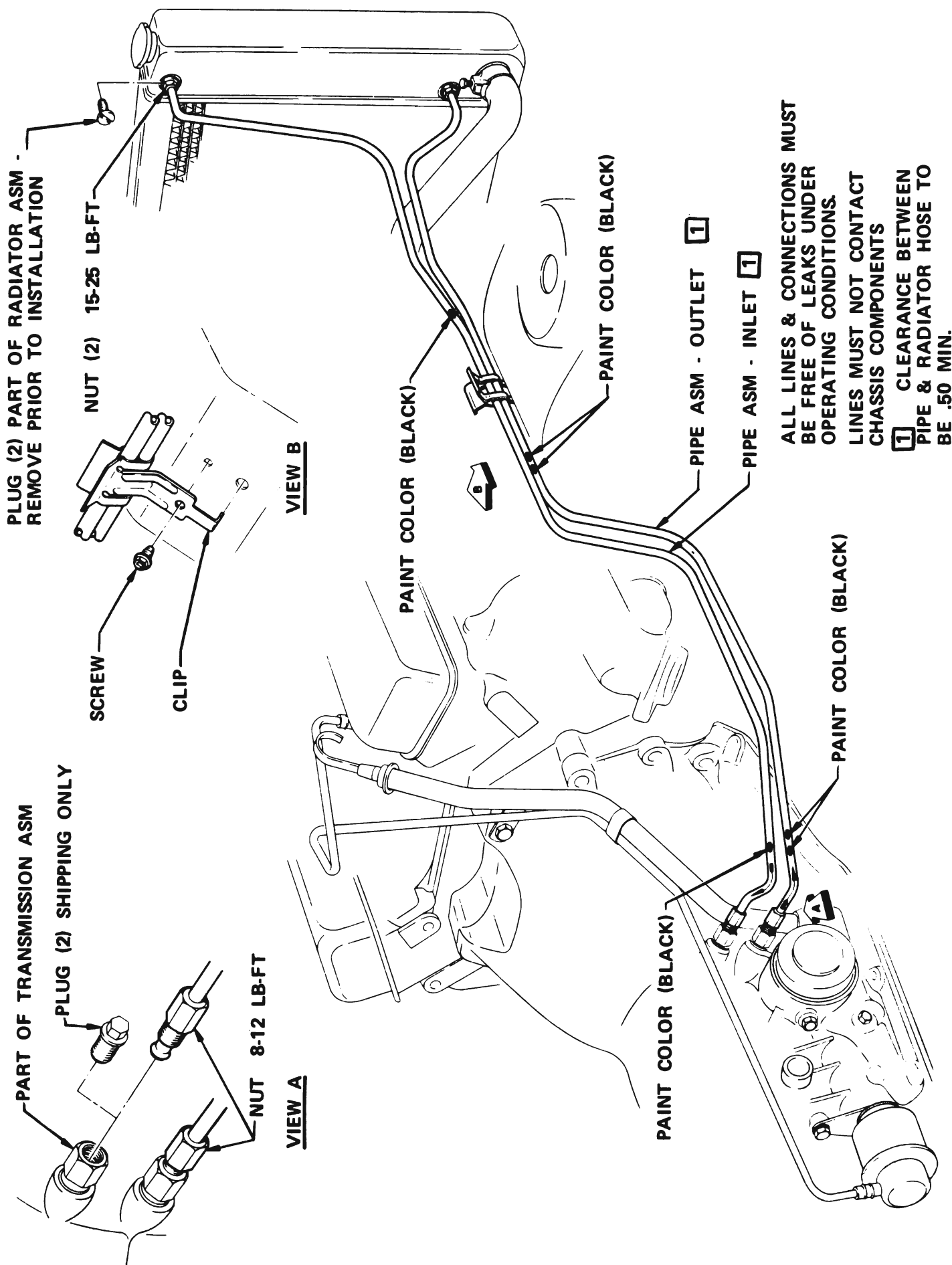

Figure 75-67A - Oil Cooler Lines (4L-4N Series)

## DIVISION V

### OVERHAUL AND MAJOR SERVICE

#### 75-15 PRELIMINARY INSTRUCTIONS

1. Before starting disassembly of the transmission it should be thoroughly cleaned externally to avoid getting dirt inside.
2. Place transmission on a CLEAN work bench and use CLEAN tools during disassembly. Provide clean storage space for parts and units removed from transmission. An excellent working arrangement is provided by assembling the transmission to Holding Fixture J-8763. See Figure 75-68.

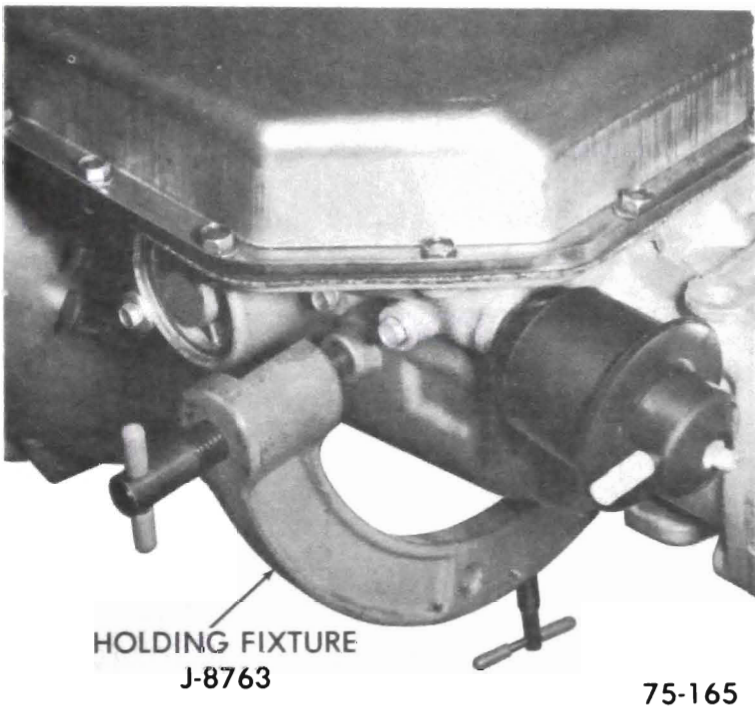

Figure 75-68

3. The transmission contains parts which are ground and highly polished, therefore, parts should be kept separated to avoid nicking and burring surfaces.

4. When disassembling transmission carefully inspect all gaskets at times of removal. The imprint of parts on both sides of an old gasket will show whether a good seal was obtained. A poor imprint indicates a possible source of oil leakage due to gasket condition, looseness of bolts, or uneven surfaces of parts.

5. None of the parts require forcing when disassembling or assembling transmission. Use a rawhide or plastic mallet to separate tight fitting cases - do not use a hard hammer.

#### 75-16 REMOVAL OF CONVERTER HOLDING TOOL J-21366, CONVERTER, VACUUM MODULATOR

##### A. Removal of Converter

Before assembling transmission in Holding Fixture J-8763 it must be modified so 1-2 accumulator will clear fixture. Remove 3/8" from Fixture as shown in Figure 75-68.

1. Assemble transmission in Fixture J-8763. Do not overtighten. See Figure 75-68.
2. Remove converter Holding Tool J-21366. See Figure 75-69.

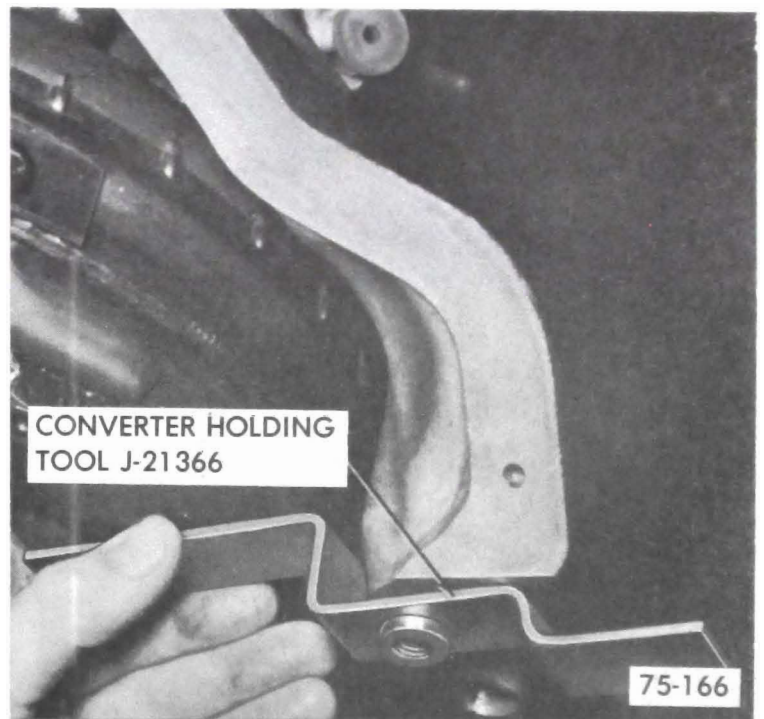

Figure 75-69

3. With transmission in Holding Fixture J-8763, remove torque converter assembly. See Figure 75-70.

##### B. Removal of Vacuum Modulator

Note that the vacuum modulator for KL Model 375B carries a different part number than for the 350.

1. Remove modulator assembly attaching bolt and retainer. See Figure 75-71.
2. Remove vacuum modulator assembly "O" ring seal and modulator valve from case. See Figure 75-72.

#### 75-17 REMOVAL OF EXTENSION HOUSING, LIP SEAL AND BUSHING



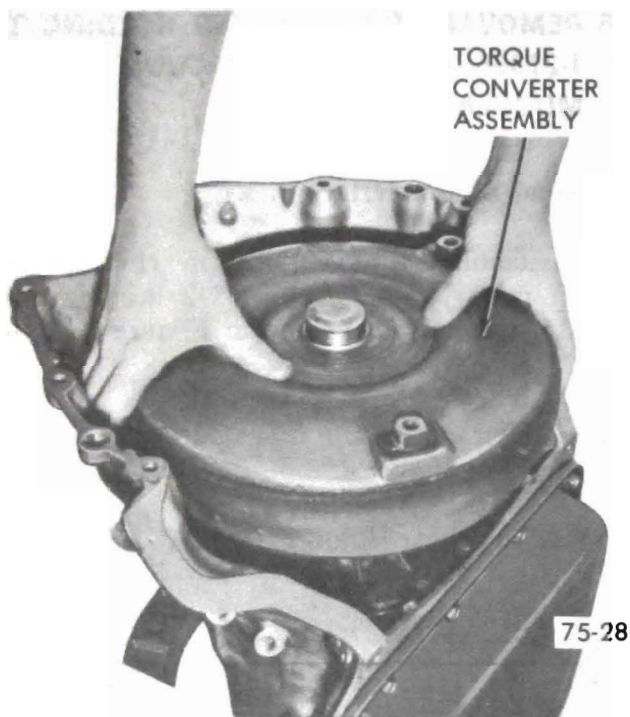

Figure 75-70

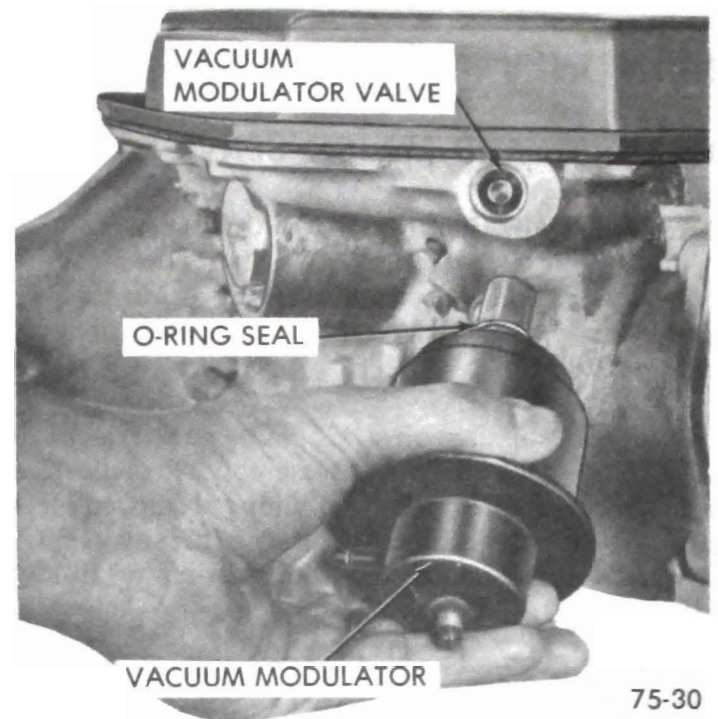

Figure 75-72

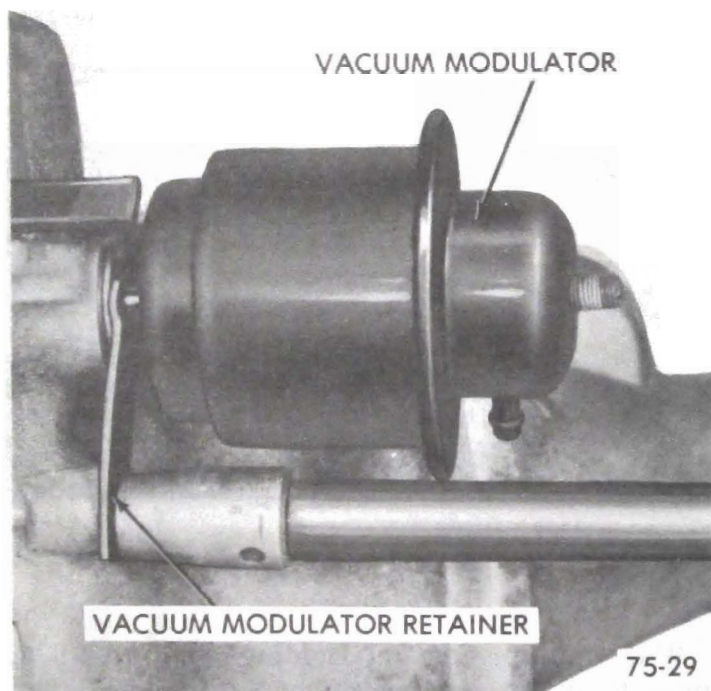

Figure 75-71

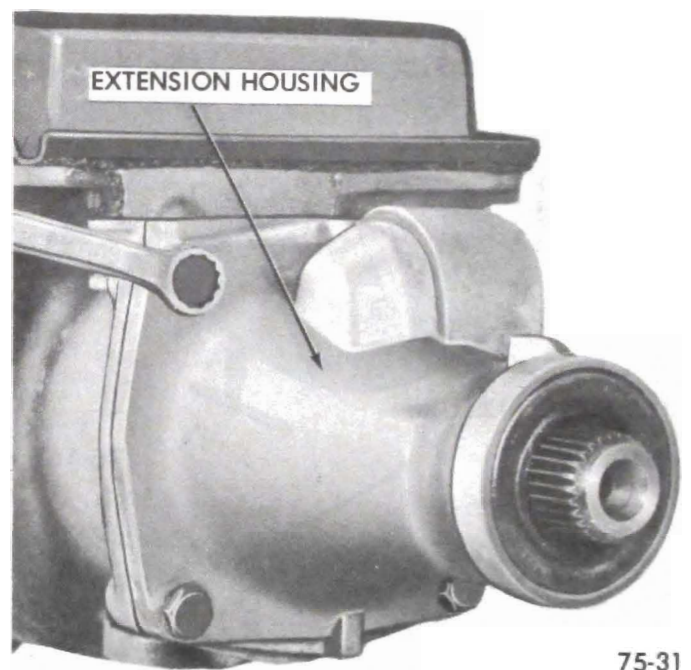

Figure 75-73

### A. Removal of Extension Housing

1. Remove bolt retainer and speedometer driven gear from side of extension housing and remove four (4) extension housing to case attaching bolts. See Figure 75-73.

### B. Removal of Extension Housing Seal

1. Remove extension housing to case oil seal. See Figure 75-74.

### C. Removal of Extension Housing Lip Seal

1. Remove extension housing lip seal using screwdriver. See Figure 75-75.

### D. Removal of Extension Housing Bushing

1. Remove extension housing bushing using screwdriver to collapse bushing. See Figure 75-76.

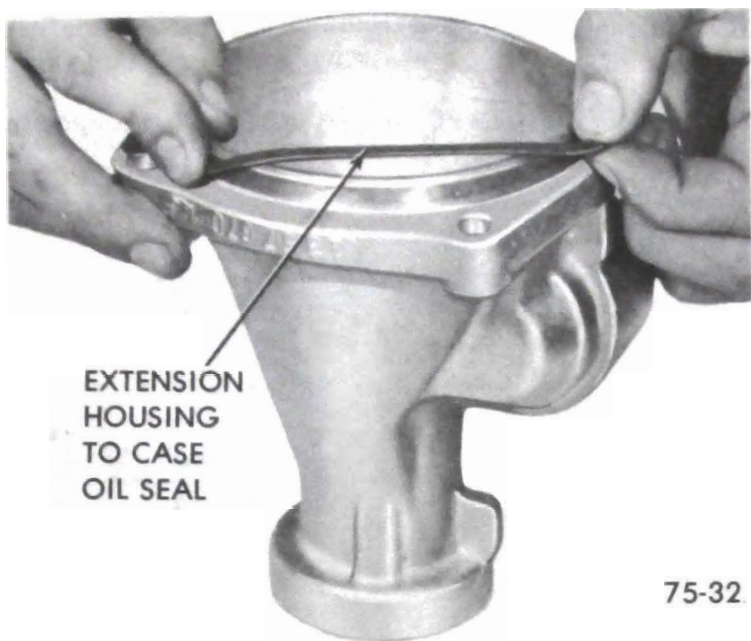

Figure 75-74

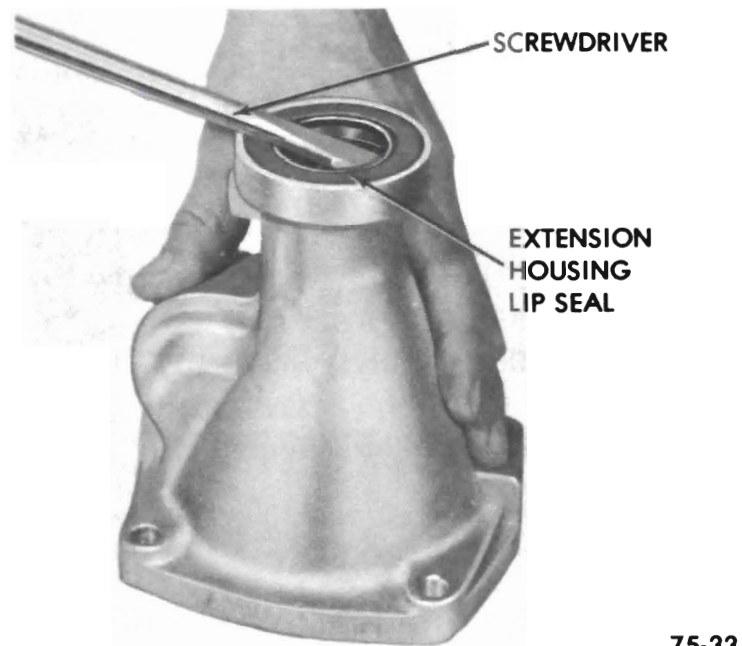

Figure 75-75

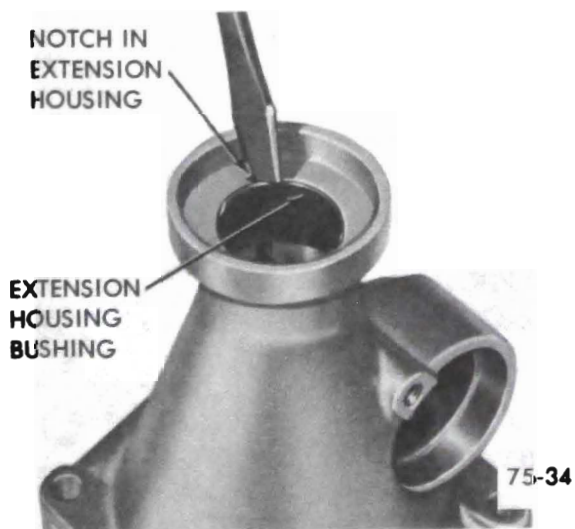

Figure 75-76

### 75-18 INSTALL EXTENSION HOUSING BUSHING AND LIP SEAL

#### A. Installation of Extension Housing Bushing

1. Install extension housing bushing using Drive Handle J-8092 and Bushing Tool J-21424-1. See Figure 75-77.

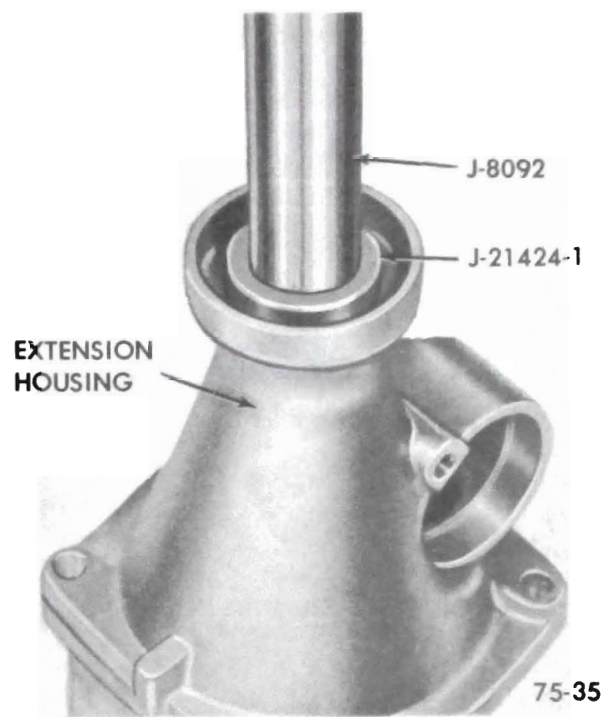

Figure 75-77

#### B. Installation of Extension Housing Lip Seal

1. Install extension housing lip seal using Installer J-21426. See Figure 75-78.

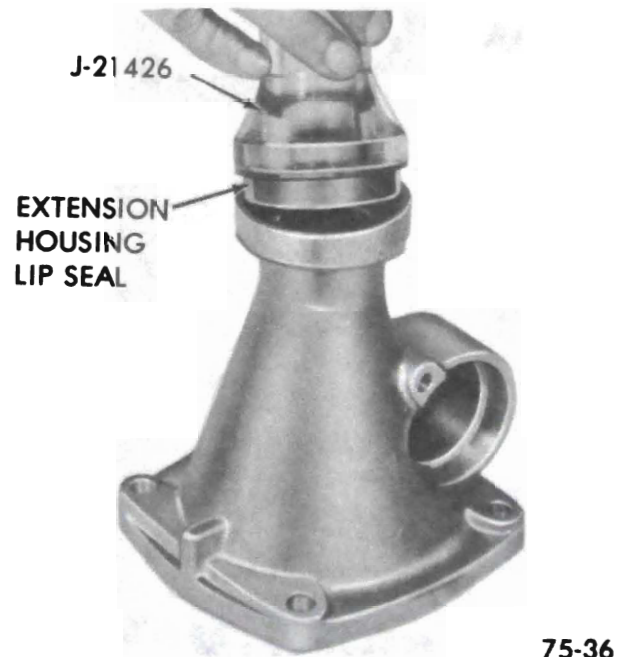

Figure 75-78



### 75-19 REMOVAL OF OIL PUMP SCREEN, GOVERNOR SCREENS, AND CHECK BALLS

Refer to sub-paragraph 75-13 for valve body removal prior to removal of oil pump screen, governor screens, and check balls.

#### A. Removal of Pressure Screen

1. Remove oil pump pressure screen from oil pump pressure hole in case, and clean. See Figure 75-79.

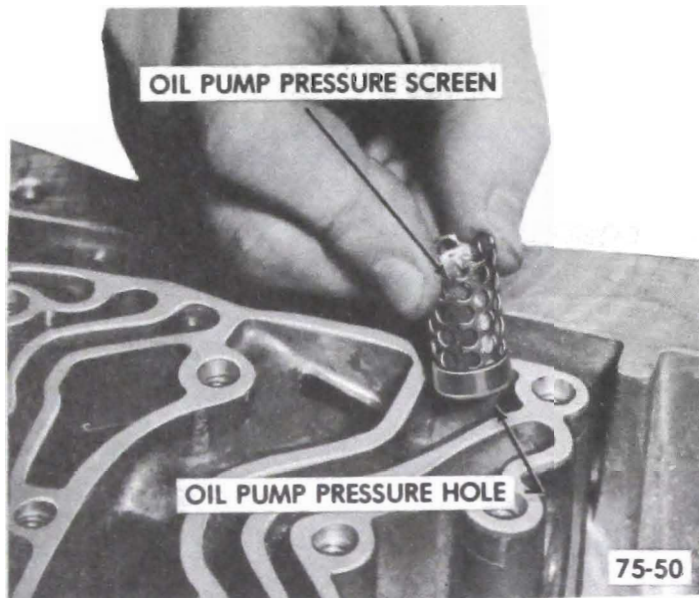

Figure 75-79

2. Remove governor screens from case and clean. See Figure 75-80.



Figure 75-80

#### B. Removal of Check Balls

1. Remove four check balls from correct passages in case face. See Figure 75-81.

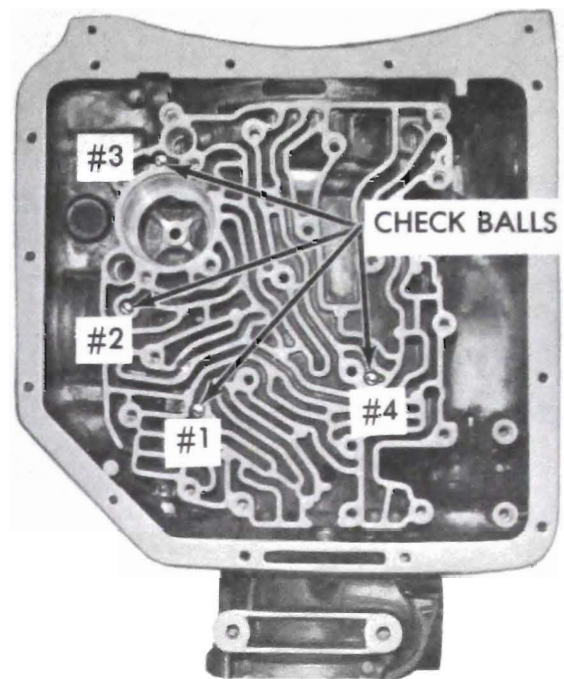

Figure 75-81

### 75-20 REMOVAL OF MANUAL SHAFT, INNER, LEVER, PARKING PAWL, AND INTERMEDIATE SERVO PISTON

#### A. Removal of Range Selector Inner Lever

1. Remove manual control valve link retainer from range selector inner lever.
2. Remove manual shaft to case retainer with screwdriver. See Figure 75-82.

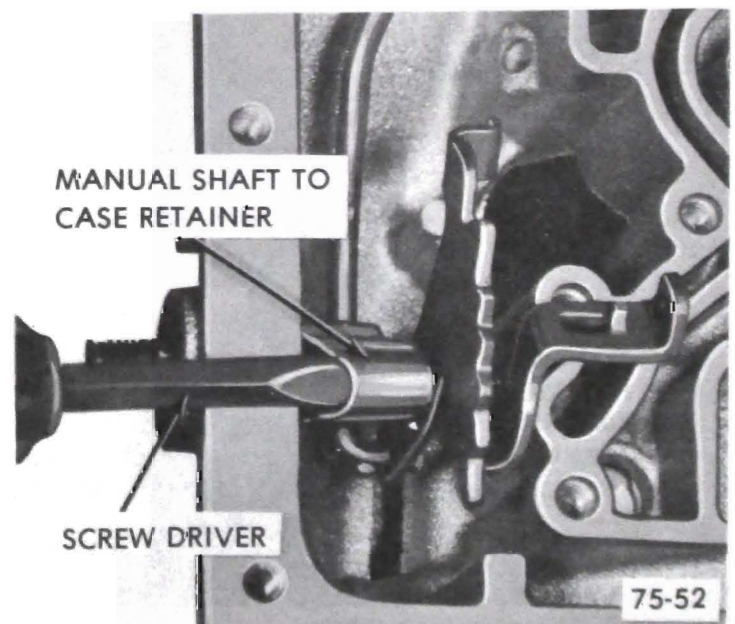

Figure 75-82



3. Remove jam nut holding range selector inner lever to manual shaft. See Figure 75-83.

**RANGE SELECTOR INNER LEVER TO MANUAL SHAFT NUT**

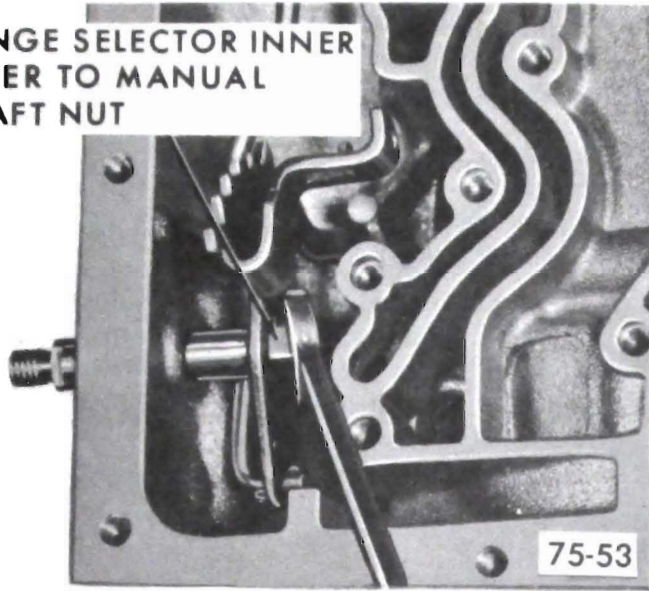

Figure 75-83

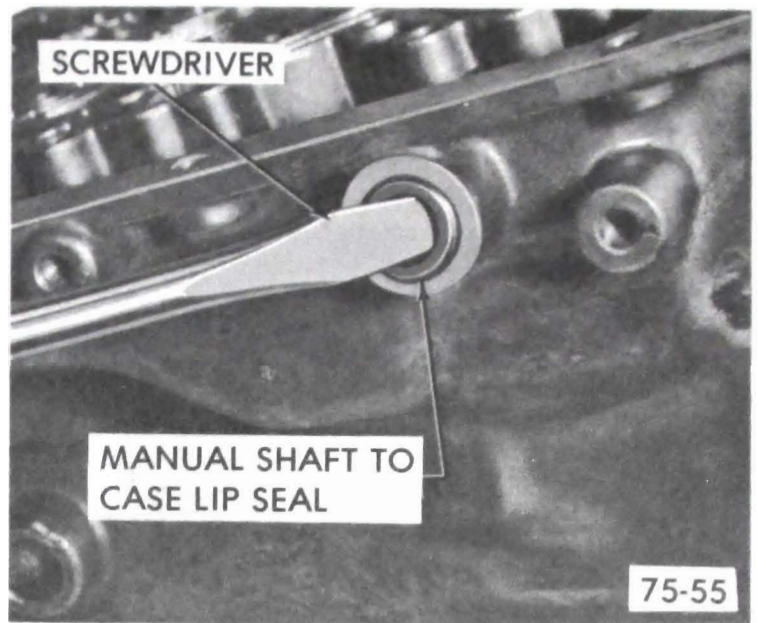

Figure 75-85

4. Remove manual shaft from case. Remove range selector inner lever and parking pawl actuating rod. See Figure 75-84.

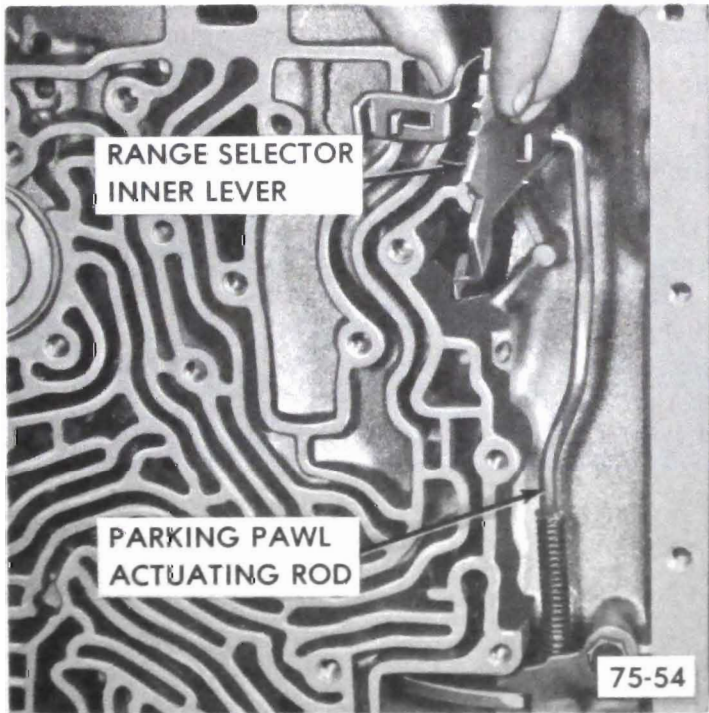

Figure 75-84

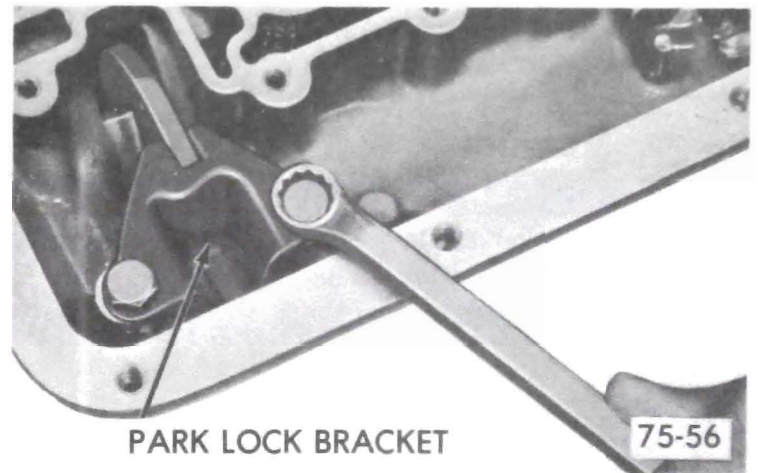

Figure 75-86

7. Remove parking pawl shaft retaining plug stake marks. Remove retaining plug, parking pawl shaft, parking pawl, and disengaging spring. See Figure 75-87.

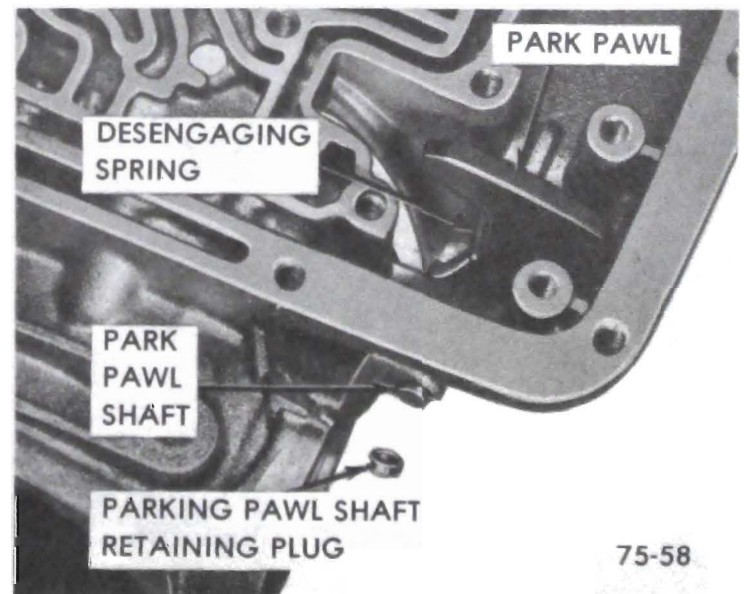

Figure 75-87

5. Remove manual shaft to case lip seal, if necessary. See Figure 75-85.

6. Removing parking lock bracket. See Figure 75-86.



**B. Removal of Intermediate Servo Piston**

1. Remove intermediate servo piston and metal oil seal ring. Remove washer, spring seat and apply pin. See Figure 75-88.

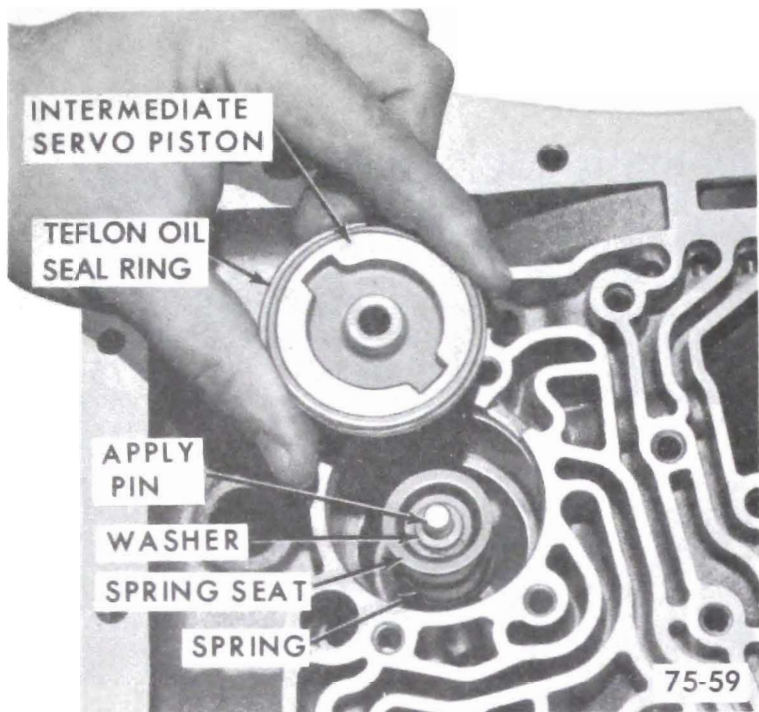

Figure 75-88

2. Check Band Apply Pin.

a. Using band apply selection pin tool J-23071, and straight edge, apply firm downward pressure on selection pin. See Figure 75-89.

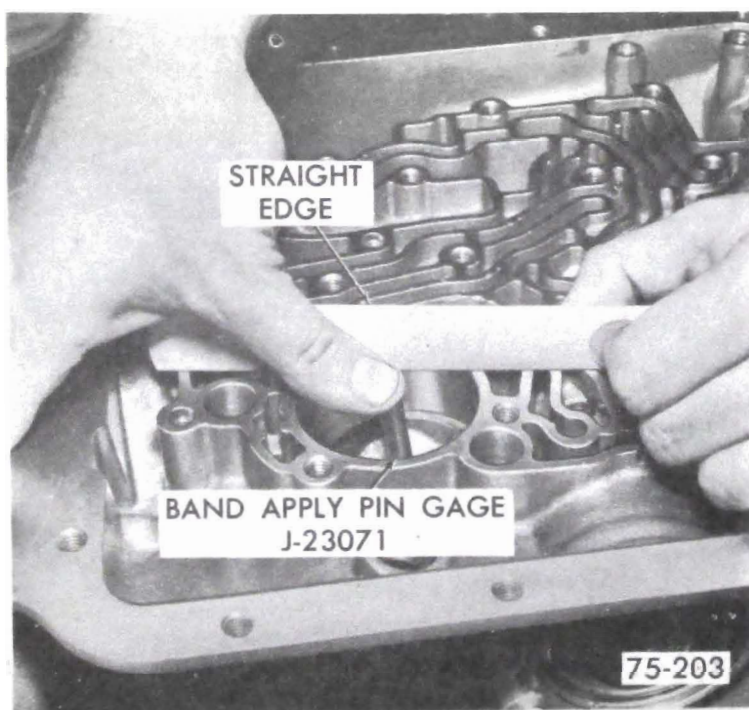

Figure 75-89

There are two selective pins available and are identified as follows:

Pin Identification . . . . . Pin Size

With Groove . . . . . Long

Without Groove . . . . . Short

If Tool J-23071 is below the straight edge surface, the long pin should be used. If the tool is above the straight edge surface, the short pin should be used. The identification groove on the selective pins is located on the band lug end of the pin. Selecting the proper pin is the equivalent of adjusting the band.

If a new pin is required, make note of pin size required, and remove Tool J-23071 from transmission case.

**75-21 REMOVAL OF PUMP ASSEMBLY, CUSHION SPRING AND INTERMEDIATE CLUTCH PLATES, AND OVERRUN BRAKE BAND**

**A. Removal of Oil Pump Assembly**

Oil pump assembly of the KL-375B Model is selected for higher pressure and carries a different part number.

1. Remove eight (8) pump attaching bolts with washer type seals. Discard washer type seals. See Figure 75-90.

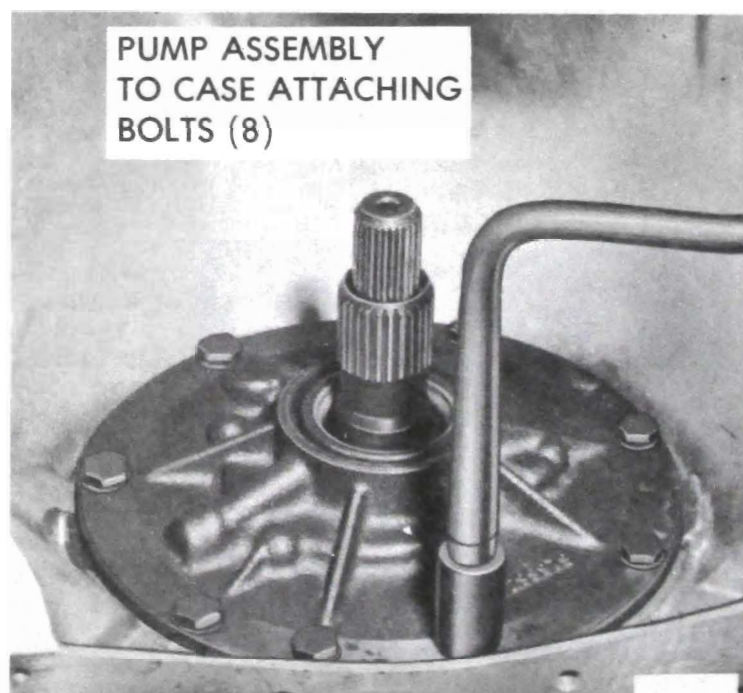

Figure 75-90



2. Install two (2) threaded slide hammers J- 7004 into threaded holes in pump body. Tighten jam nuts and remove pump assembly from case. See Figure 75-91.

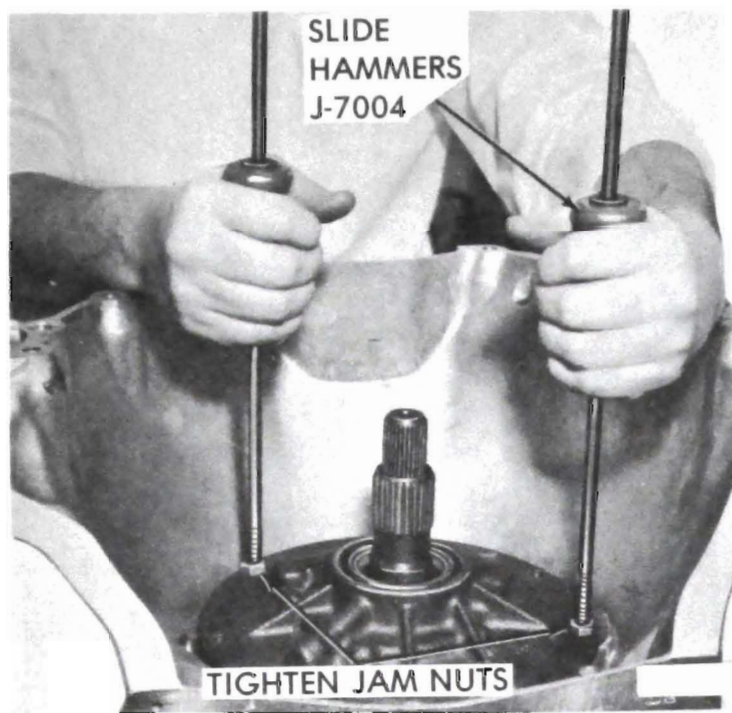

Figure 75-91

3. Remove pump assembly to case gasket and discard. See Figure 75-92.

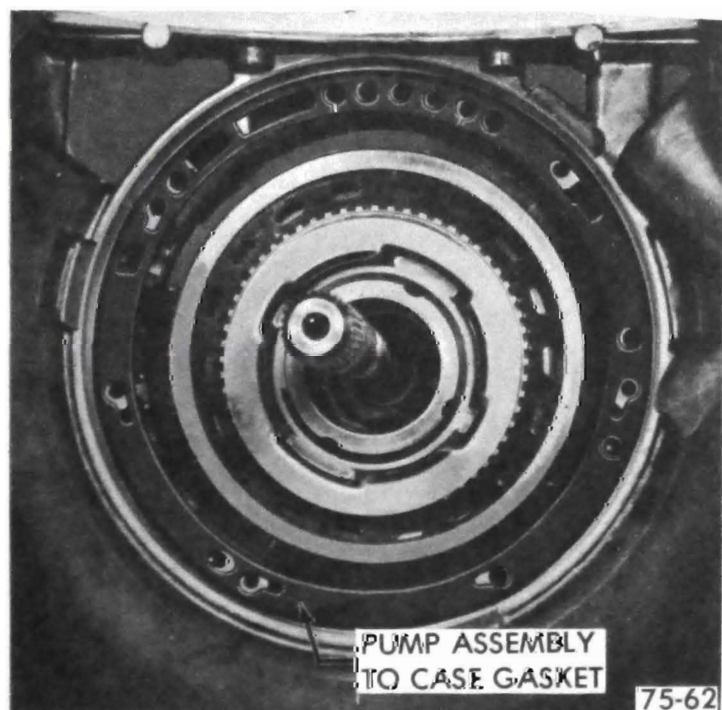

Figure 75-92

#### B. Removal of Intermediate Clutch Cushion Spring, Intermediate Clutch Plates and Intermediate Overrun Brake Band

1. Remove intermediate clutch cushion spring. See Figure 75-93.

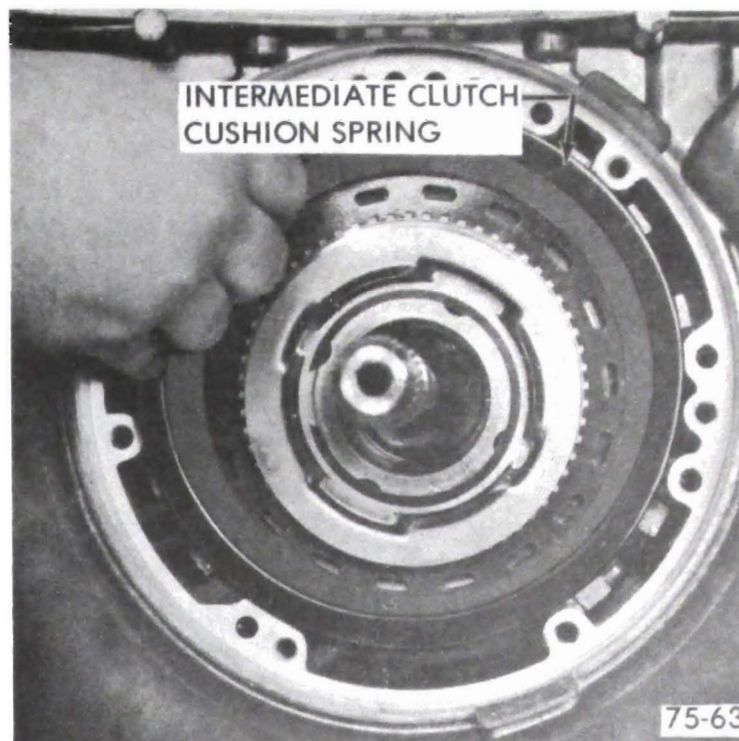

Figure 75-93

2. Remove three (3) intermediate clutch faced plates and three (3) steel separator plates. See Figure 75-94.

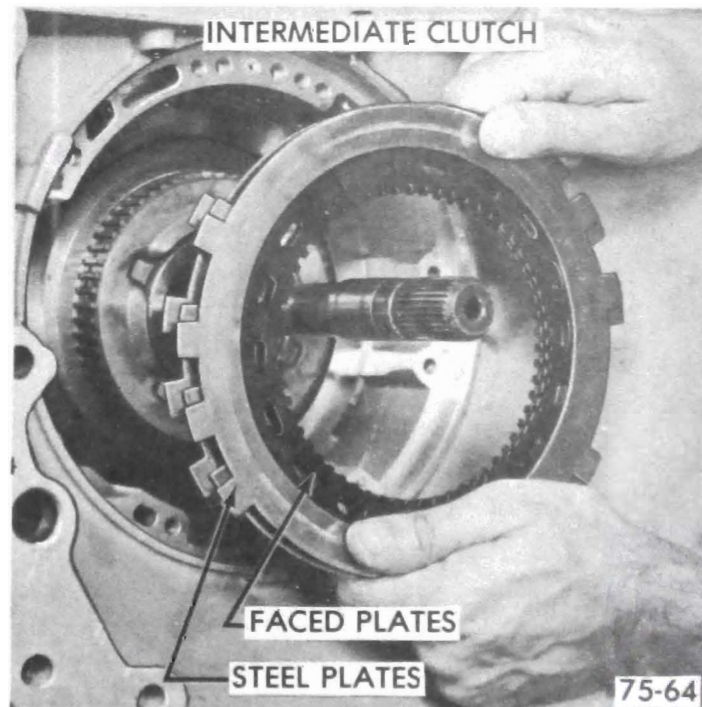

Figure 75-94

3. Inspect condition of the lined and steel plates. *Do not diagnose a lined drive plate by color.*

A. Dry lined plates with compressed air and inspect the lined surfaces for:

1. Pitting and flaking



2. Wear.
3. Glazing
4. Cracking
5. Charring
6. Chips or metal particles imbedded in lining

If a lined drive plate exhibits any of the above conditions, replacement is required.

B. Wipe steel plates dry and check for heat discoloration. If the surface is smooth and an even color smear is indicated, the plates should be reused. If severe heat spot discoloration or surface scuffing is indicated, the plates must be replaced.

4. Remove intermediate clutch pressure plate. See Figure 75-95.

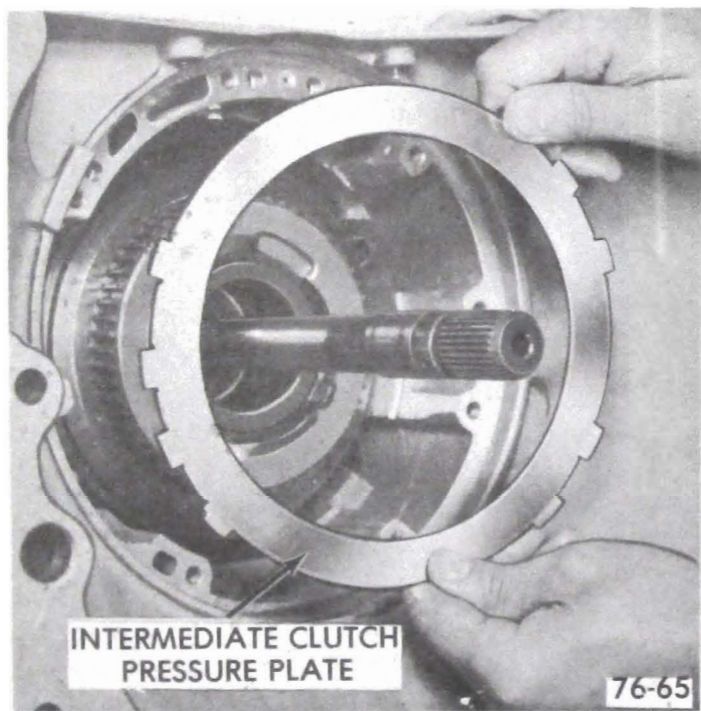

Figure 75-95

5. Remove intermediate overrun brake band. See Figure 75-96.

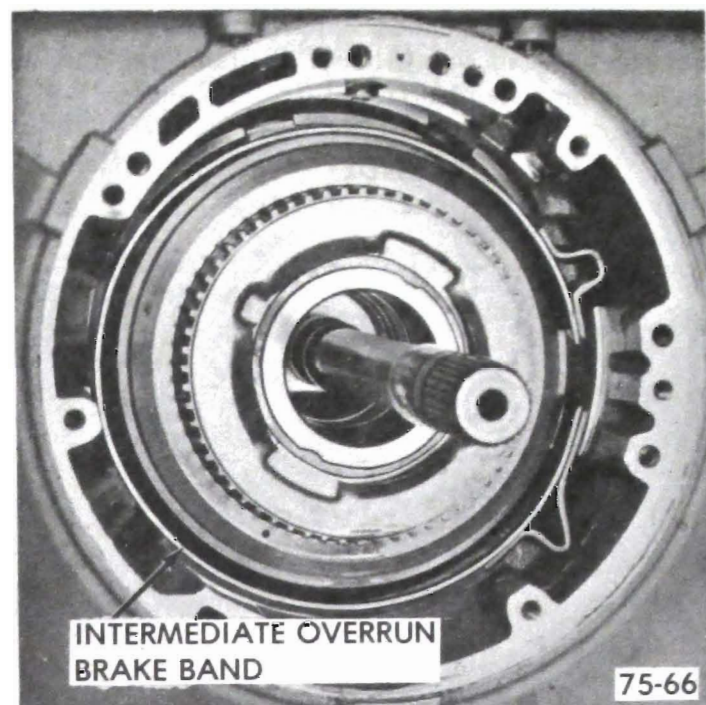

Figure 75-96

#### 75-22 REMOVAL OF DIRECT AND FORWARD CLUTCH ASSEMBLIES, INPUT RING GEAR, AND OUTPUT CARRIER

##### A. Removal of Direct and Forward Clutch Assemblies

1. Remove direct and forward clutch assemblies from case. See Figure 75-97.

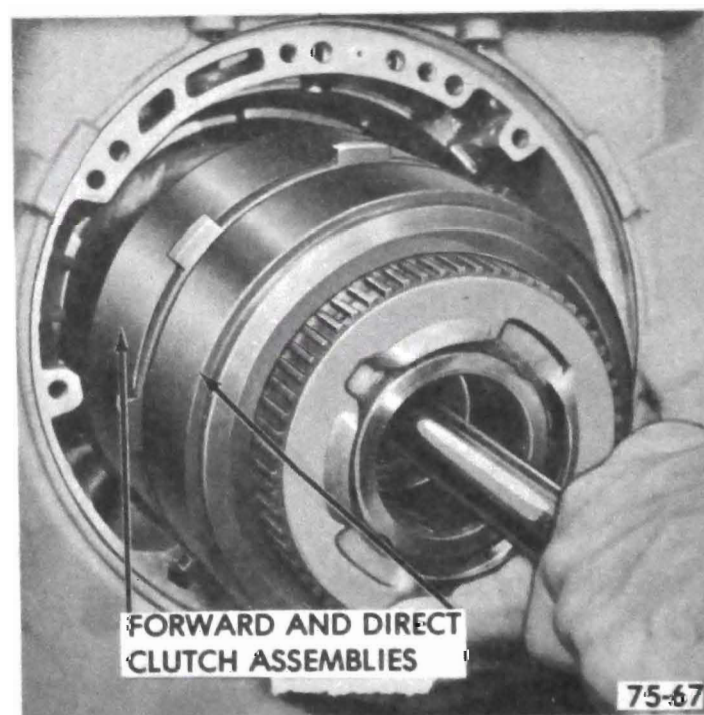

Figure 75-97



**B. Removal of Input Ring Gear**

1. Remove forward clutch housing to input ring gear - front thrust washer. See Figure 75-98.

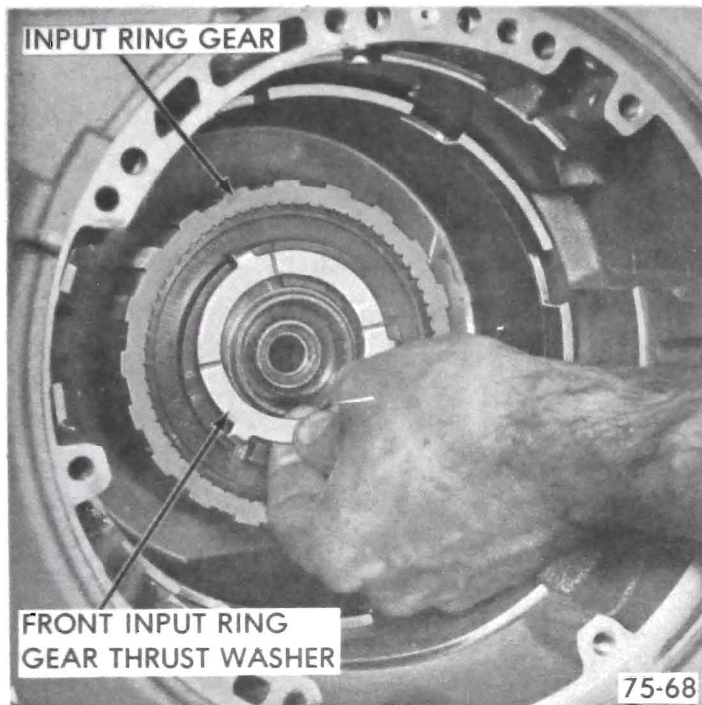

Figure 75-98

2. Remove input ring gear. See Figure 75-99.

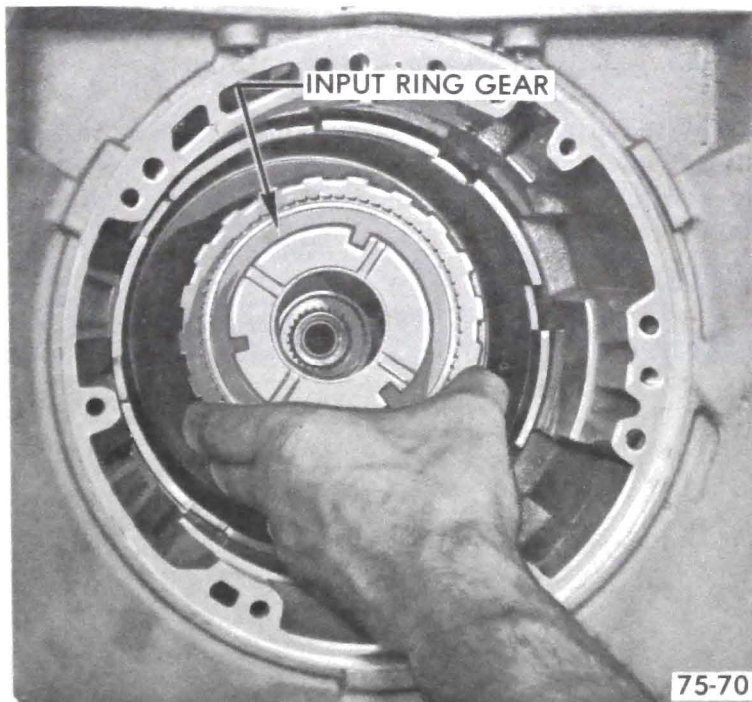

Figure 75-99

3. Inspect bushing for wear or galling. If replacement is necessary proceed as follows:

a. Thread Tool J-23062-5 on Drive Handle J-8092,

and remove bushing from ring gear. See Figure 75-100.

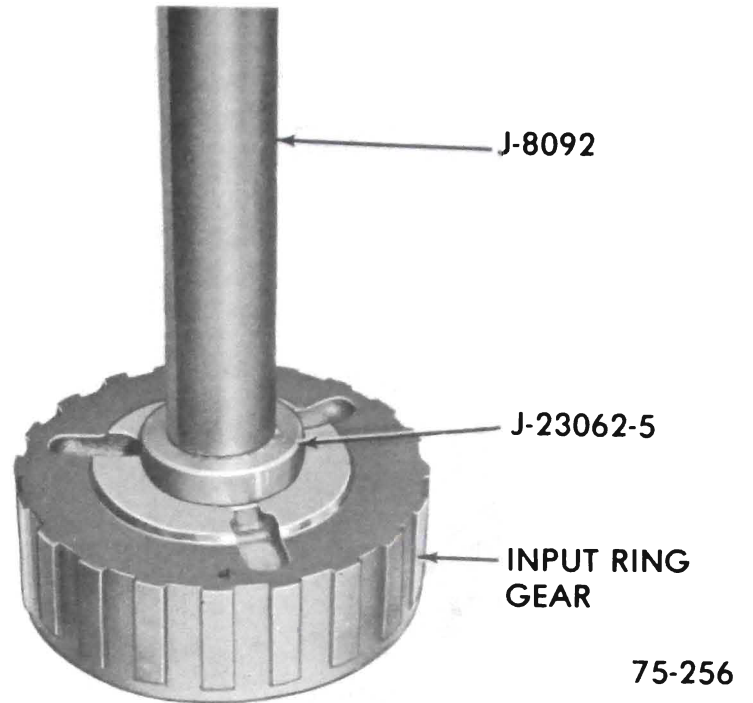

Figure 75-100

b. Using Tool J-23062-5, press in new bushing .050" to .060" from inner surface of hub. See Figure 75-100.

**C. Removal of Output Carrier Assembly**

1. Remove input ring gear to output carrier thrust washer. See Figure 75-101.

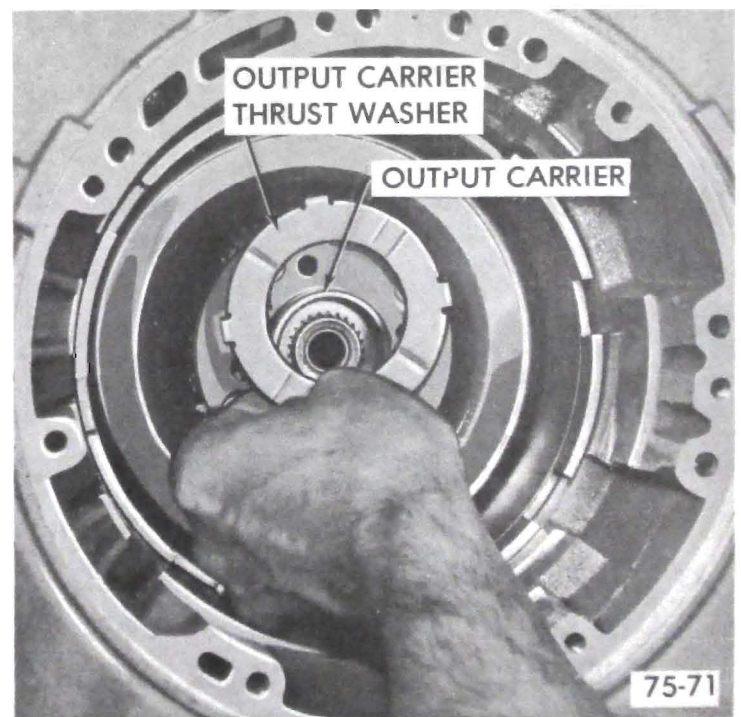

Figure 75-101



2. Remove output carrier to output shaft snap ring and discard. See Figure 75-102.

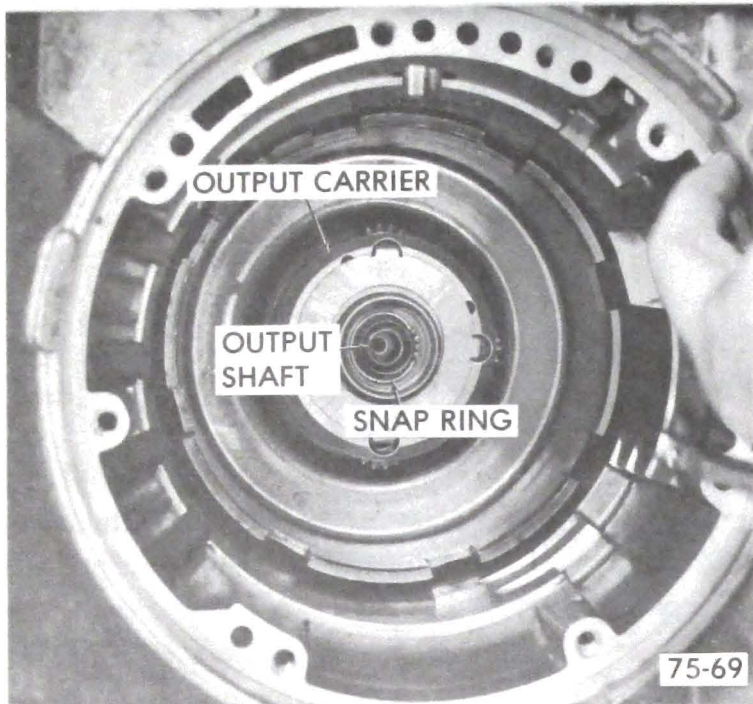

Figure 75-102

3. Remove output carrier assembly. See Figure 75-103.

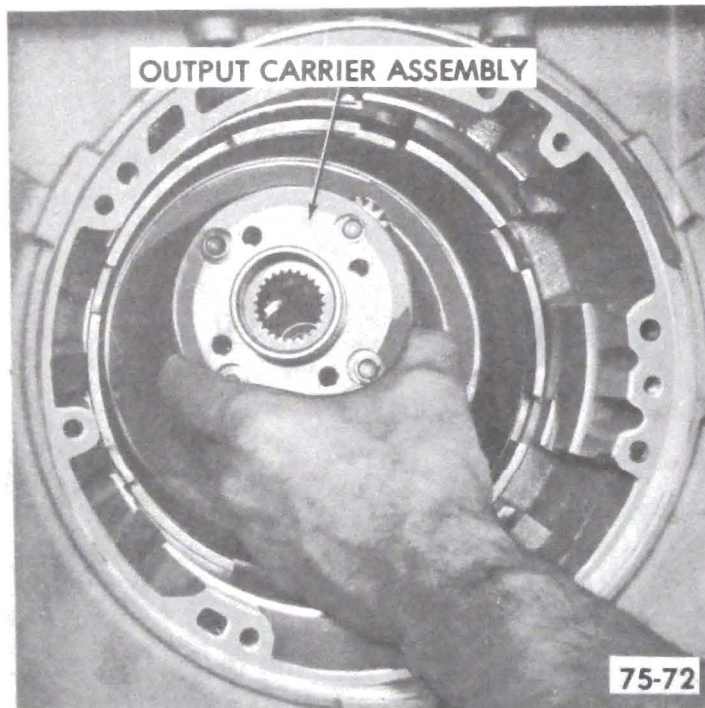

Figure 75-103

### A. Removal of Sun Gear Drive Shell Assembly

1. Remove sun gear drive shell assembly. See Figure 75-104.

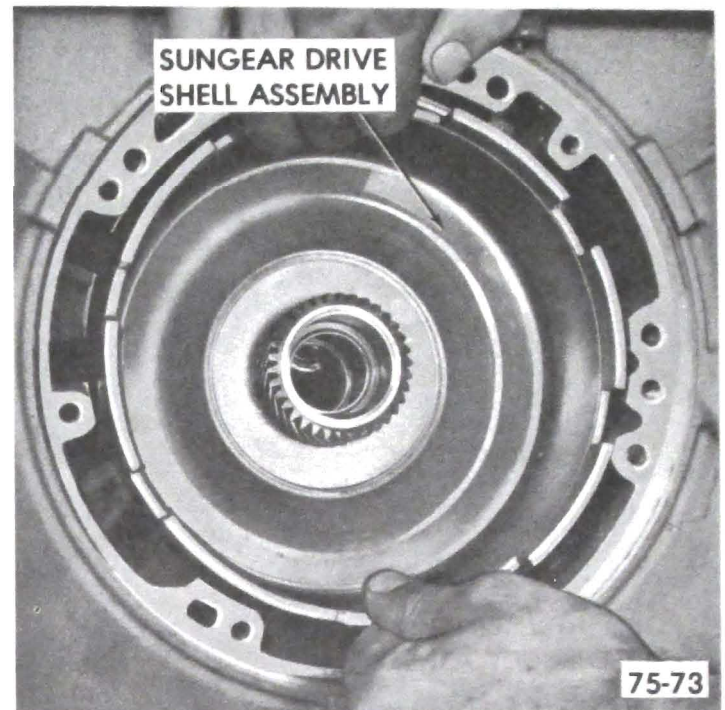

Figure 75-104

### B. Removal of Low and Reverse Clutch Support Assembly

1. Remove low and reverse roller clutch support to case retaining ring. See Figure 75-107.
2. Grasp output shaft and pull up until low and reverse roller clutch and support assembly clear low and reverse clutch support retainer spring and remove support assembly. See Figure 75-106.

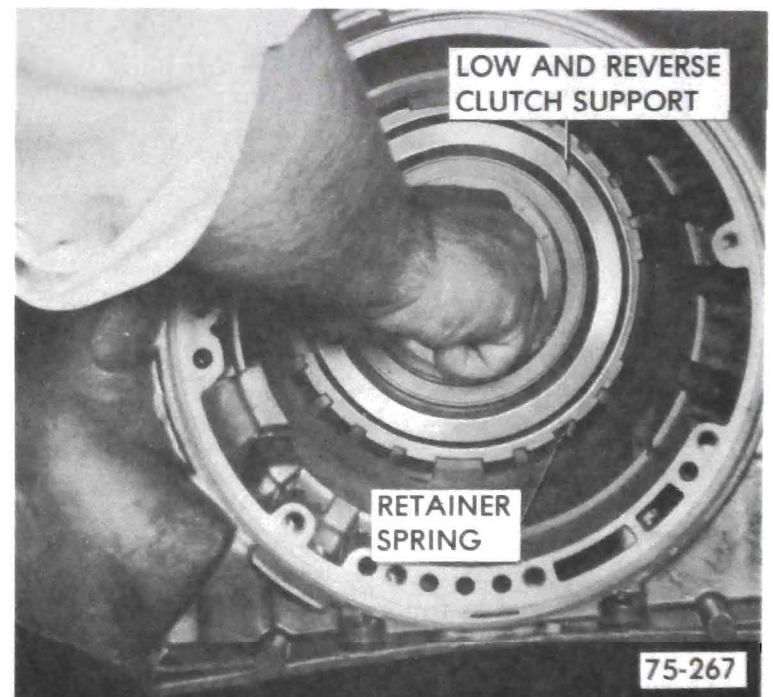

Figure 75-106

**75-23 REMOVAL OF SUN GEAR DRIVE SHELL, LOW AND REVERSE CLUTCH SUPPORT ASSEMBLY, LOW AND REVERSE CLUTCH PLATES, AND REACTION CARRIER**



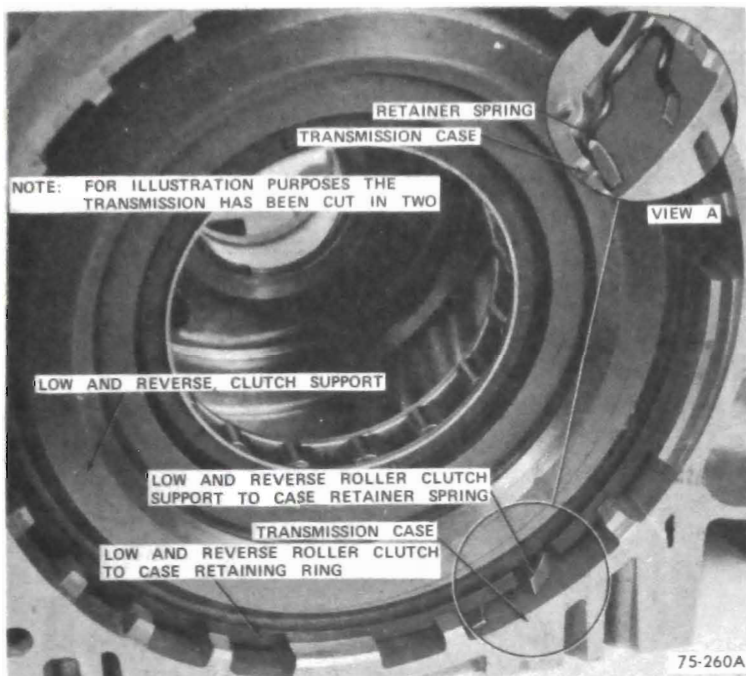

Figure 75-107

3. Remove low and reverse clutch support retainer spring. See Figure 75-107.

**C. Removal of Low and Reverse Clutch Plates**

1. Remove five (5) low and reverse clutch faced plates and five (5) steel separator plates. See Figure 75-108.

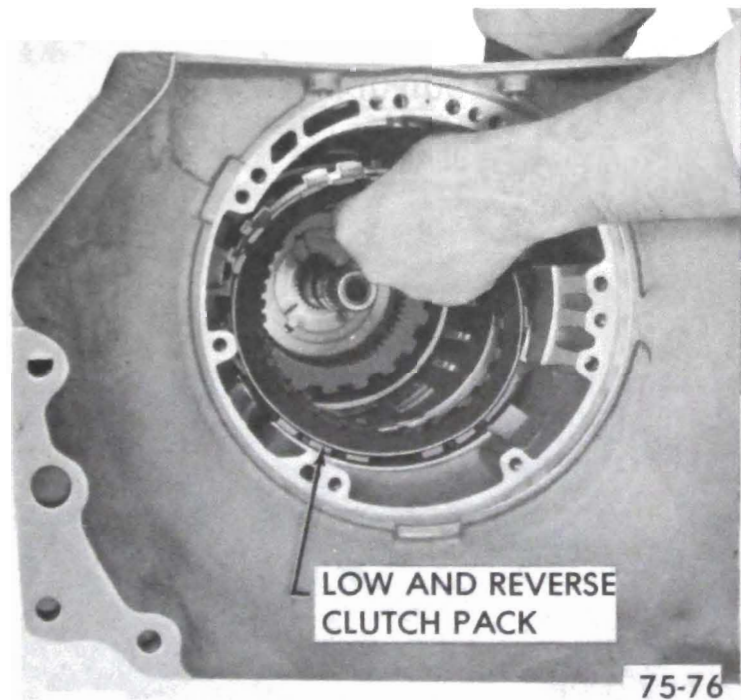

Figure 75-108

1. Remove reaction carrier assembly from output ring gear and shaft assembly. See Figure 75-109.

2. Inspect reaction carrier bushing for wear or galling. If replacement is necessary proceed as follows:

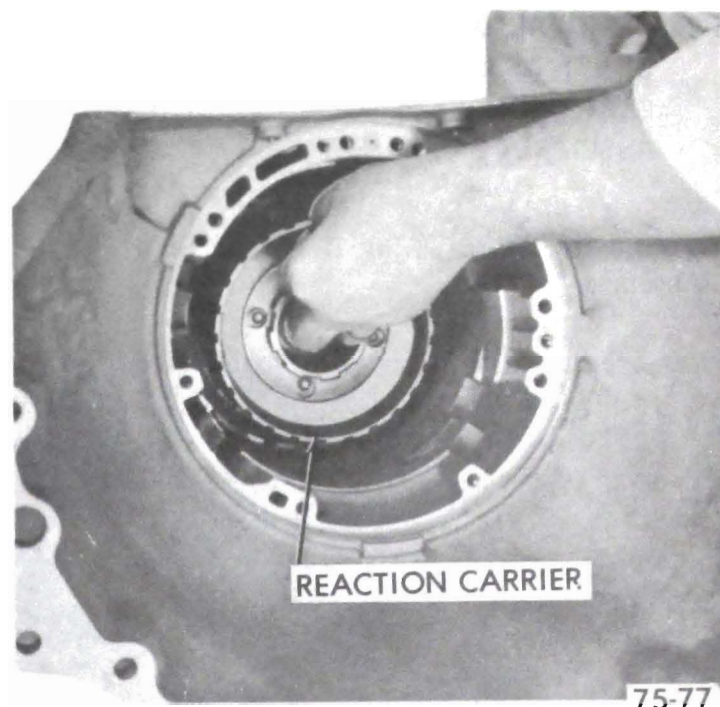

Figure 75-109

**D. Removal of Reaction Carrier Assembly**

a. Thread tool J-23062-3 on Drive Handle J-8092 and remove bushing. See Figure 75-110.

b. Using Tool J-23062-3 press in new bushing flush to .010" from inner surface of hub. See Figure 75-110.

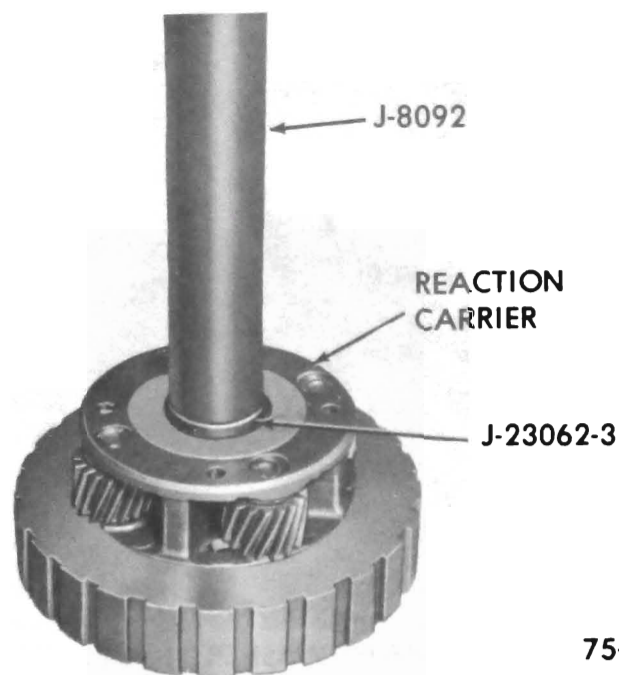

Figure 75-110



**75-24 REMOVAL OF OUTPUT RING GEAR AND SHAFT ASSEMBLY, AND OUTPUT RING GEAR TO CASE NEEDLE BEARING ASSEMBLY**

**A. Removal of Output Ring Gear and Shaft Assembly**

1. Remove output ring gear and shaft assembly from case. See Figure 75-111.

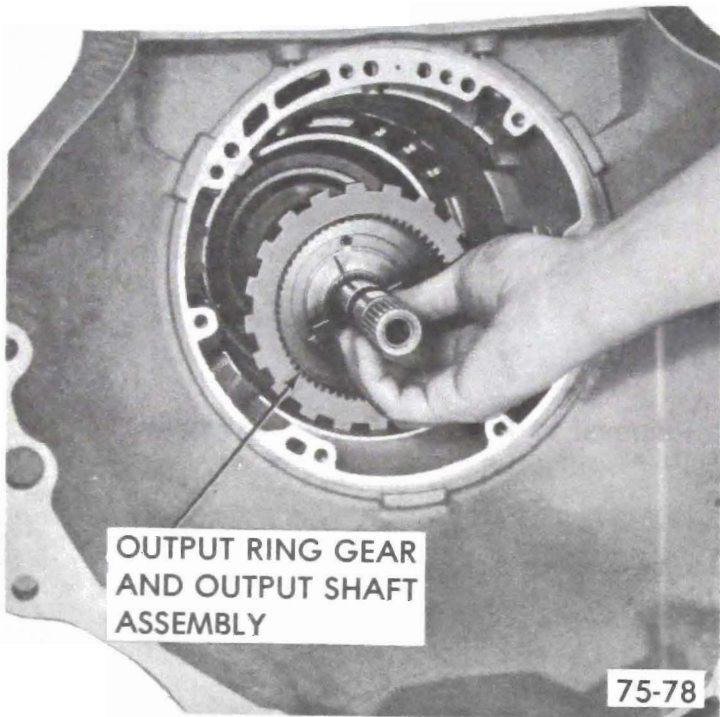
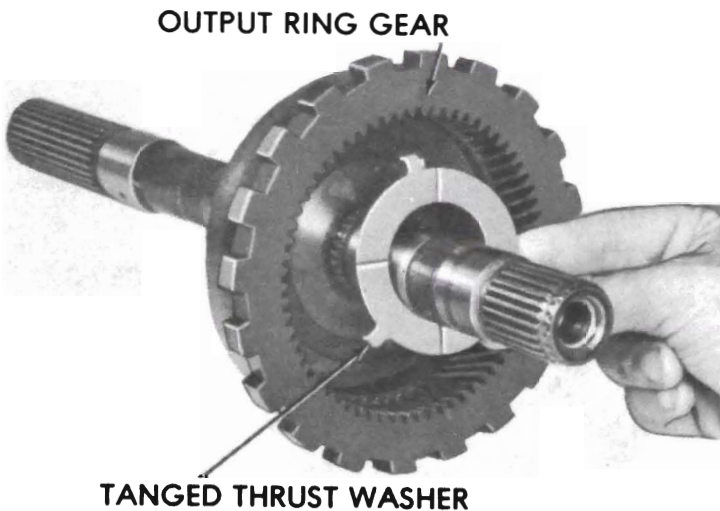

Figure 75-111

2. Remove reaction carrier to output ring gear tanged thrust washer. See Figure 75-112.



75-79

Figure 75-112

3. Remove output ring gear to output shaft snap ring and *discard* . Remove output ring gear from output shaft. See Figure 75-113.

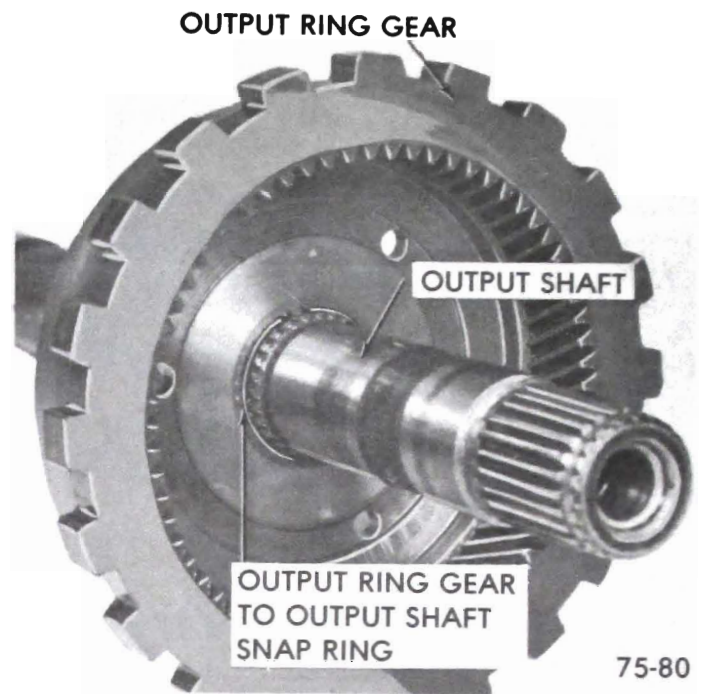

Figure 75-113

4. Remove output ring gear to case needle bearing assembly. See Figure 75-114.



Figure 75-114

5. Inspect output shaft bushing for wear or galling. If replacement is necessary proceed as follows:

a. Assemble J-9534-01 into Adapter J-2619-4 and assemble to Slide Hammer J-2619. Thread assembly into bushing. Clamp slide hammer into vise, grasp output shaft and remove bushing. See Figure 75-115.

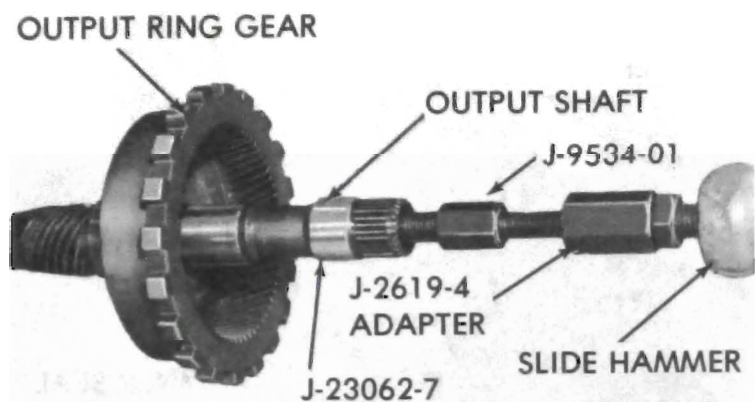

75-257

Figure 75-115

clutch piston spring retainer and remove piston retaining ring and spring retainer. See Figure 75-117.

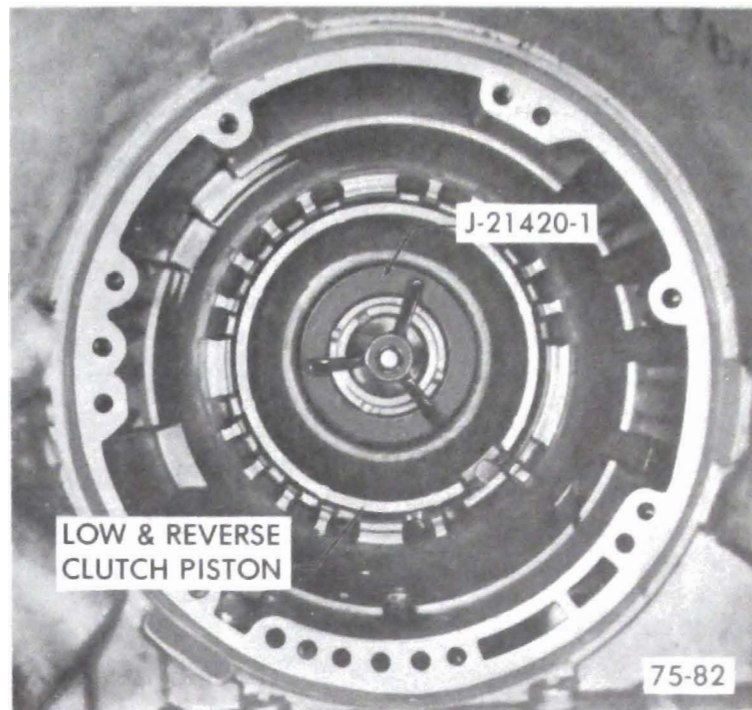

Figure 75-117

b. Using Tool J-23062-7, assembled into Drive Handle J-8092, press in new bushing .140" below end surface of shaft. See Figure 75-116.

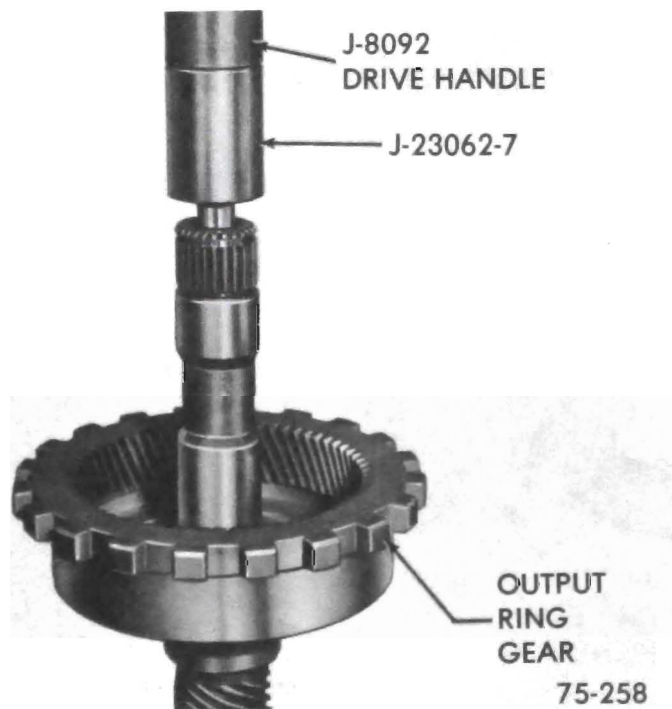

Figure 75-116

2. Remove seventeen (17) piston return coil springs from piston. See Figure 75-118.

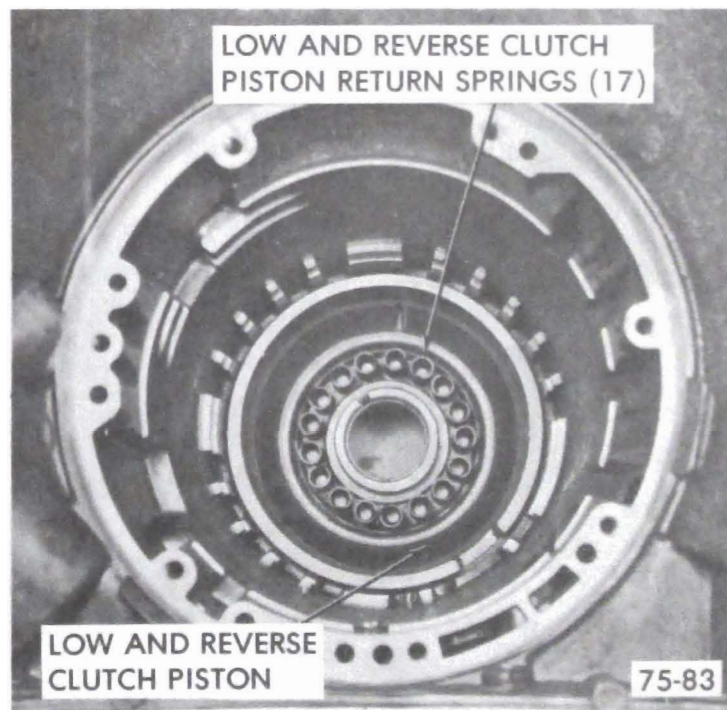

Figure 75-118

3. Remove low and reverse clutch piston assembly. Aid removal with the use of compressed air in passage shown. See Figure 75-119.

**B. Removal of Low and Reverse Clutch Piston Seals**

1. Remove low and reverse clutch piston outer seal. See Figure 75-120.

**75-25 REMOVAL OF LOW AND REVERSE CLUTCH PISTON, AND CASE BUSHING**

**A. Removal of Low and Reverse Clutch Piston**

1. Using Tool J-21420-1 compress low and reverse



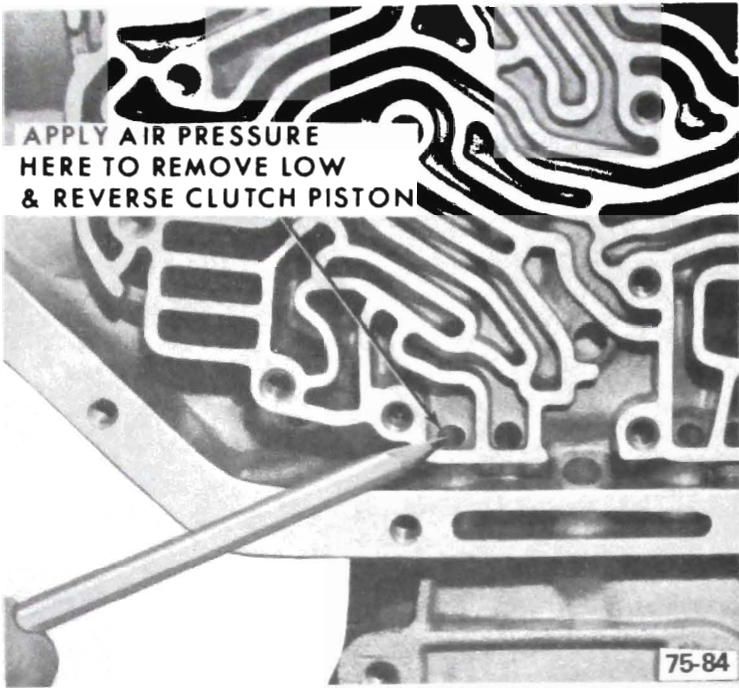

Figure 75-119

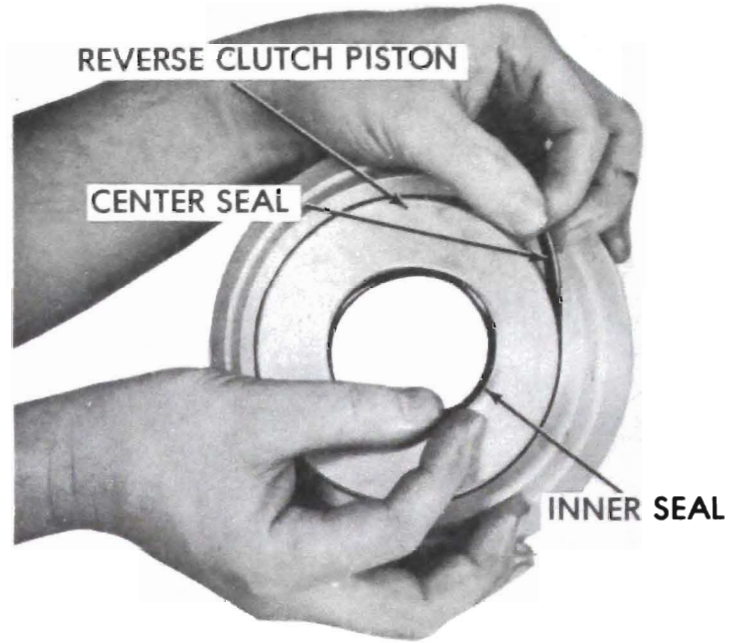

Figure 75-121

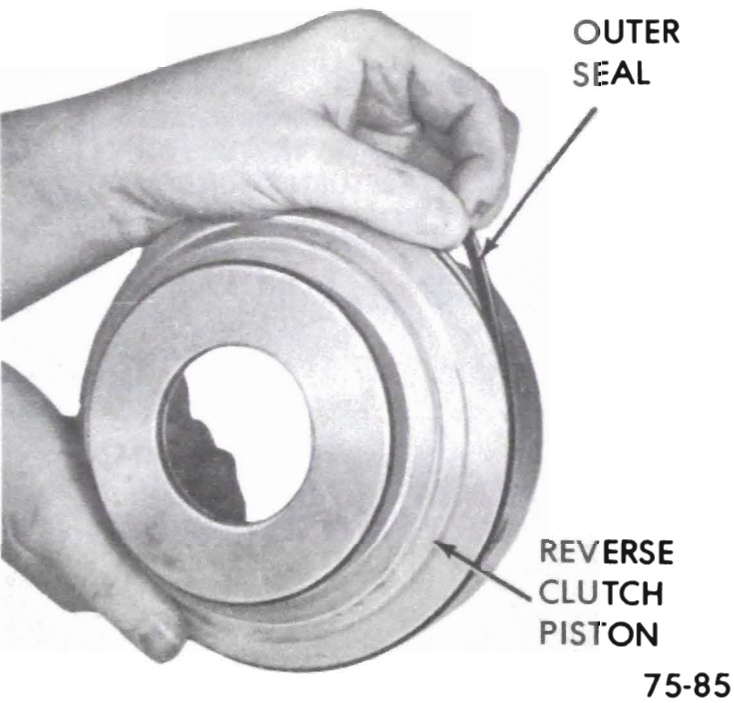

Figure 75-120

**C. Removal and Installation of Case Bushing**

1. Inspect case bushing for nicks, scoring or excessive wear. If damaged, remove as follows: Assemble Tool J-23062-1 on Drive Handle J-8092 and remove bushing. See Figure 75-122.
2. Using Tool J-23062-1 and Drive Handle J 8092,

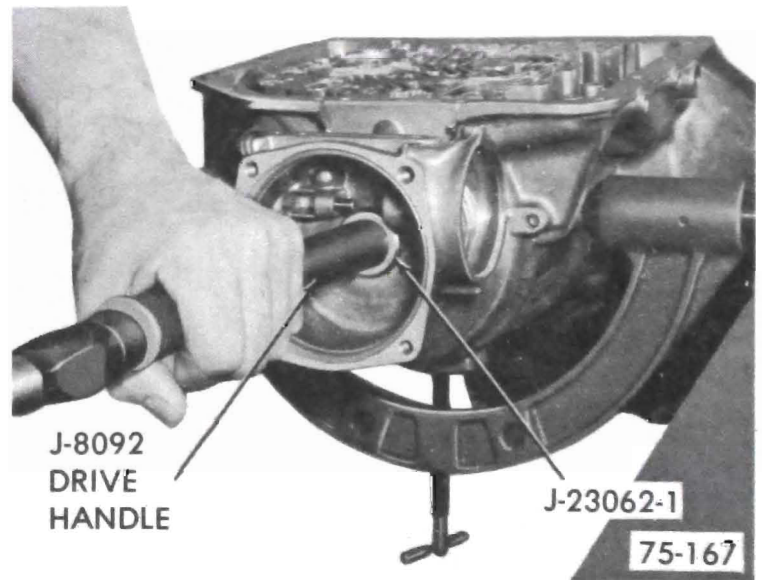

Figure 75-122

2. Remove low and reverse clutch piston center and inner seal. See Figure 75-121.

press bushing to .195" below chamfered edge of case. Make certain split on bushing is opposite notch in case. See Figure 75-123.



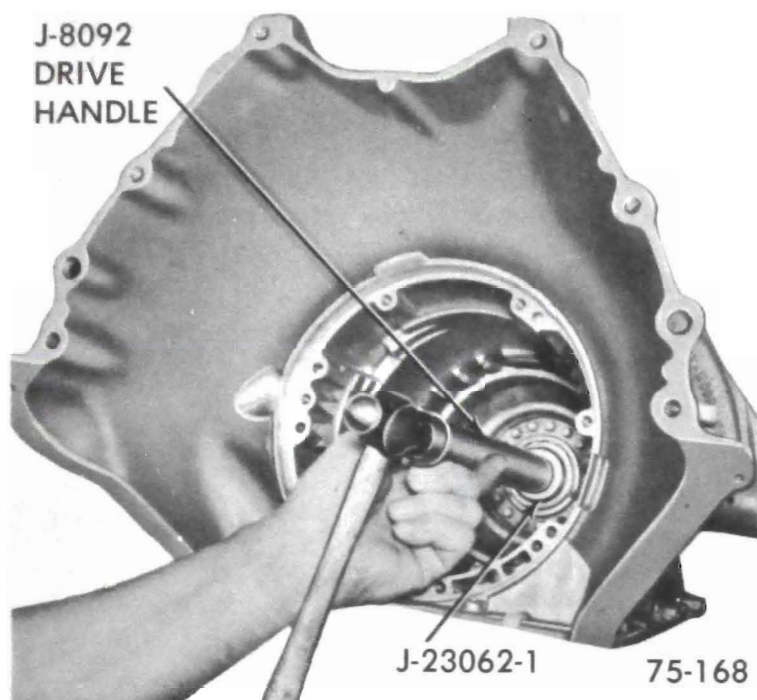

Figure 75-123

## 75-26 REMOVAL AND INSTALLATION OF INTERMEDIATE CLUTCH ACCUMULATOR

Removal and installation of intermediate clutch accumulator can be done without removal of transmission from car.

### A. Removal of Intermediate Clutch Accumulator Piston

1. Install Tool J-23069 to compress intermediate clutch accumulator cover and remove retaining ring. See Figure 75-124.

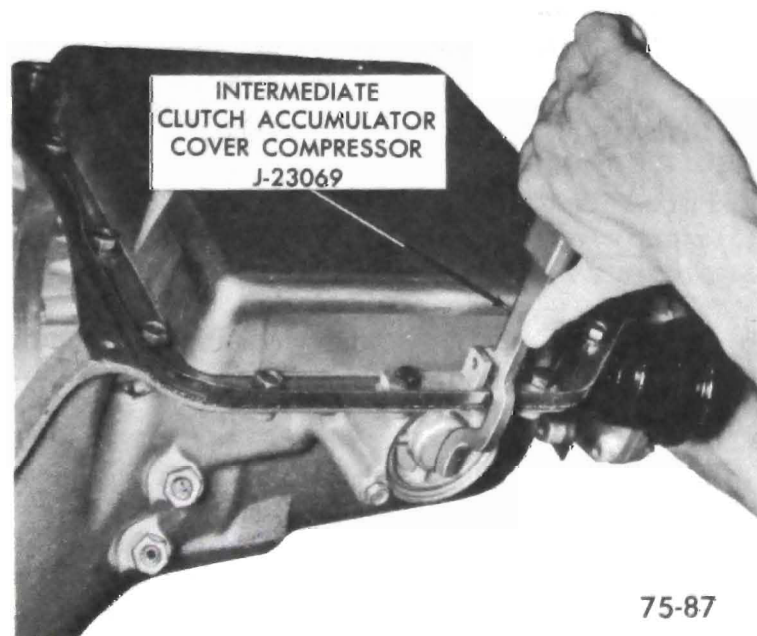

Figure 75-124

2. Remove intermediate clutch accumulator piston cover and "O" ring seal from case. See Figure 75-125.



Figure 75-125

A production day and shift built number, transmission model and model year are stamped on the intermediate clutch accumulator piston cover. If cover is replaced, this information must be stamped on new cover.

3. Remove intermediate clutch accumulator piston spring. See Figure 75-126.

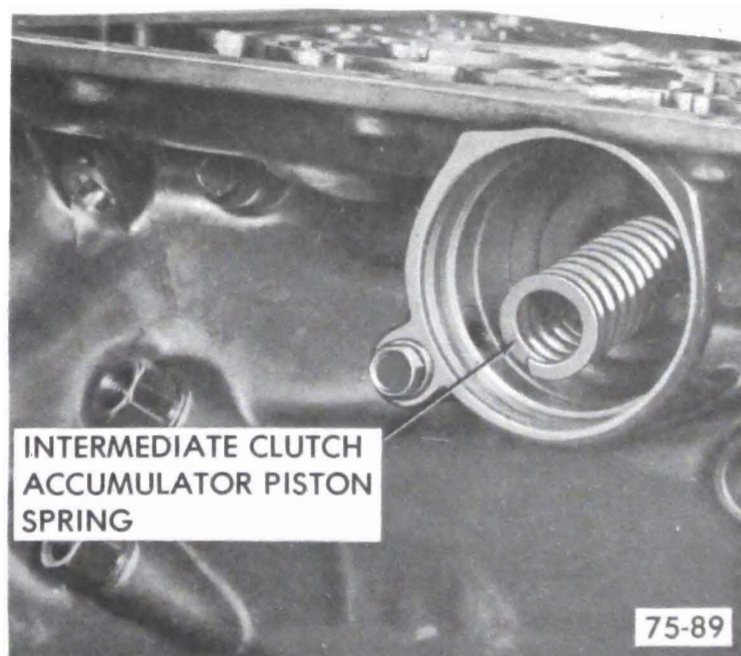

Figure 75-126

4. Remove intermediate clutch accumulator piston assembly. *Inspect the inner and outer teflon oil seal rings for wearing or scoring. DO NOT REMOVE THESE*

**TWO RINGS UNLESS THEY ARE DAMAGED.** If replacement of one or the other of the two rings is necessary, use the Service replacement rings which are hook-type rings. See Figure 75-127.

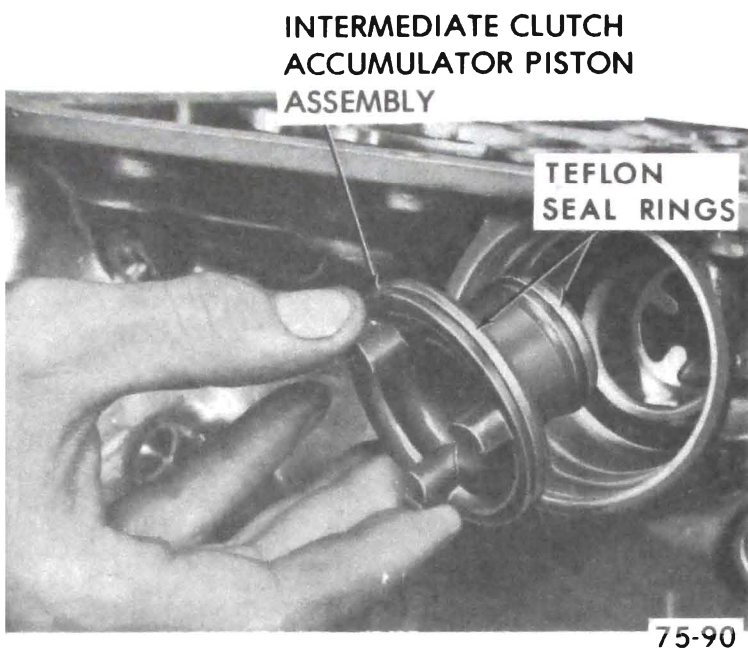

Figure 75-127

#### B. Installation of Intermediate Clutch Accumulator Piston

1. Install inner and outer hook type oil seal rings, if required. Install intermediate clutch accumulator piston assembly. See Figure 75-127.
2. Install intermediate clutch accumulator piston spring. See Figure 75-126.
3. Place "O" ring seal on intermediate clutch accumulator piston cover, and install cover into case. See Figure 75-129.

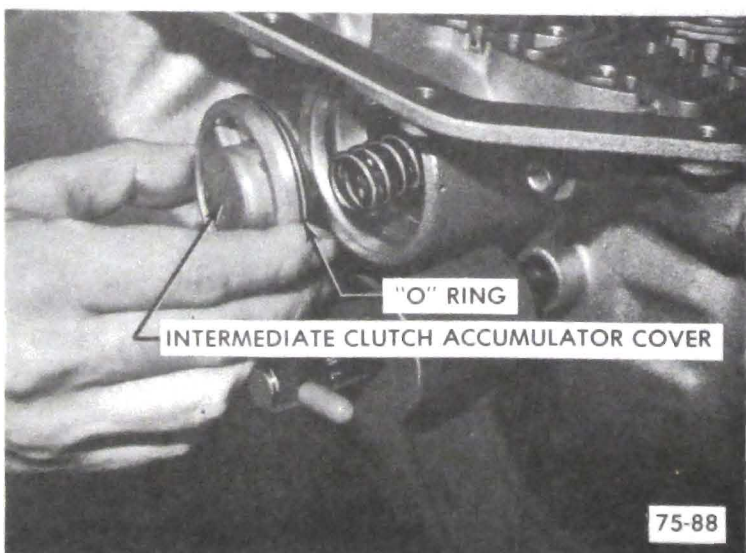

Figure 75-129

"O" ring seal must be installed on intermediate clutch accumulator piston cover before cover is installed into case.

4. Install J-23069 tool and compress intermediate clutch accumulator cover and install retaining ring. See Figure 75-130.

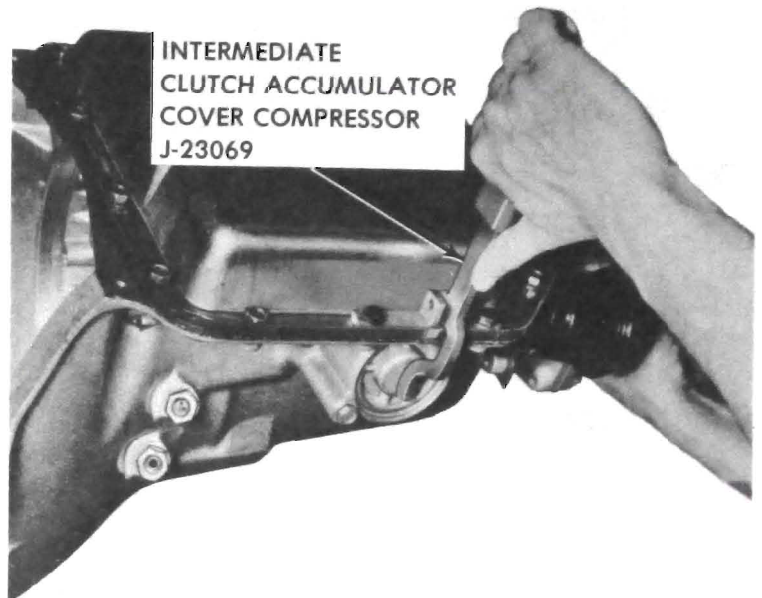

Figure 75-130

The retaining ring should be checked for correct free diameter before installation. Minimum diameter should be 2-13/16" and is required to properly seat ring in groove to properly retain cover. If required, carefully reshape retaining ring to obtain minimum diameter.

#### 75-27 DISASSEMBLY AND REASSEMBLY OF OIL PUMP ASSEMBLY

##### A. Disassembly of Oil Pump Assembly

1. Place assembly through hole in bench. Remove five (5) pump cover to body attaching bolts. Remove spring seat retainer. See Figure 75-132.
2. Remove twenty (20) intermediate clutch return springs and the intermediate clutch piston assembly. See Figure 75-133.
3. Remove intermediate clutch piston inner and outer seals. See Figure 75-134.
4. Remove three (3) direct clutch to pump hub hook type oil rings. Remove pump cover to direct clutch drum selective thrust washer. Inspect the two (2) forward clutch to pump hub teflon oil seal rings, but do not remove them unless they are damaged. If



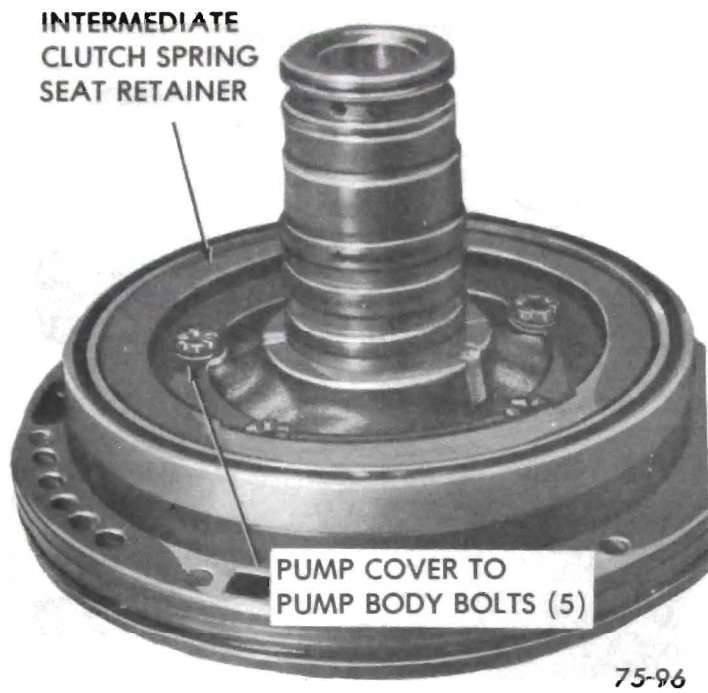

Figure 75-132

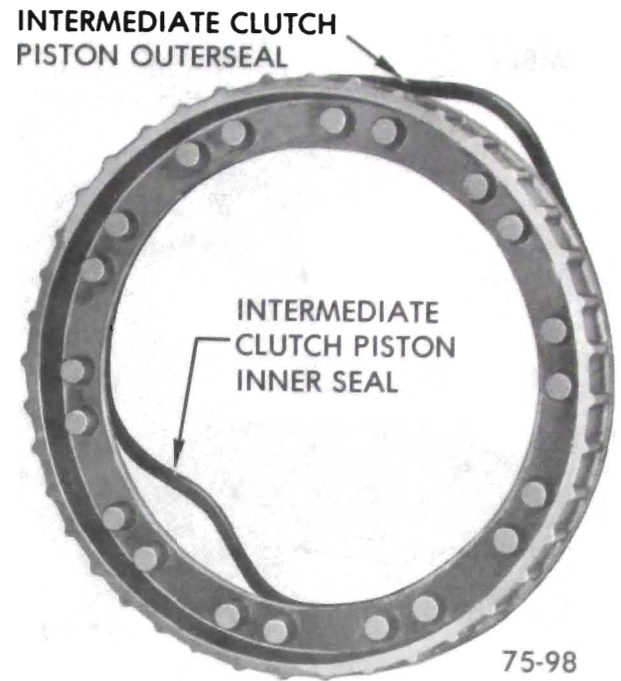

Figure 75-134

replacement is necessary, use two metal hook type service replacement rings. See Figure 75-135.

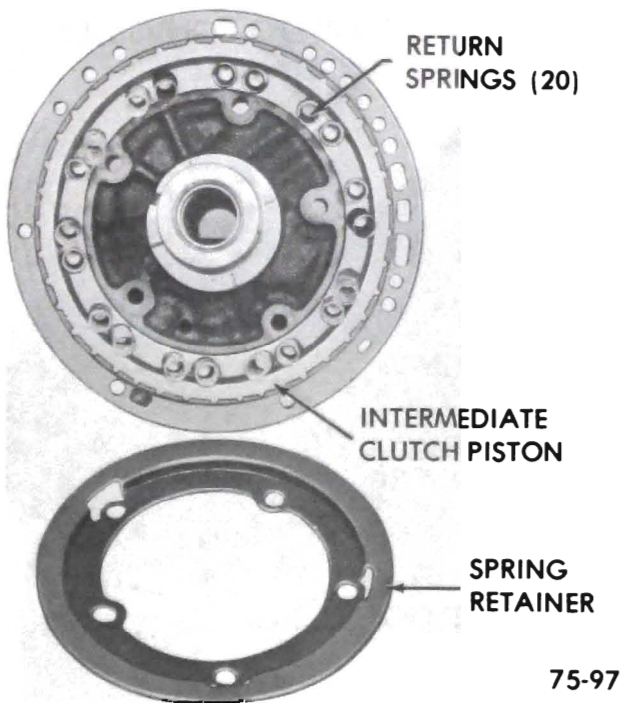

Figure 75-133

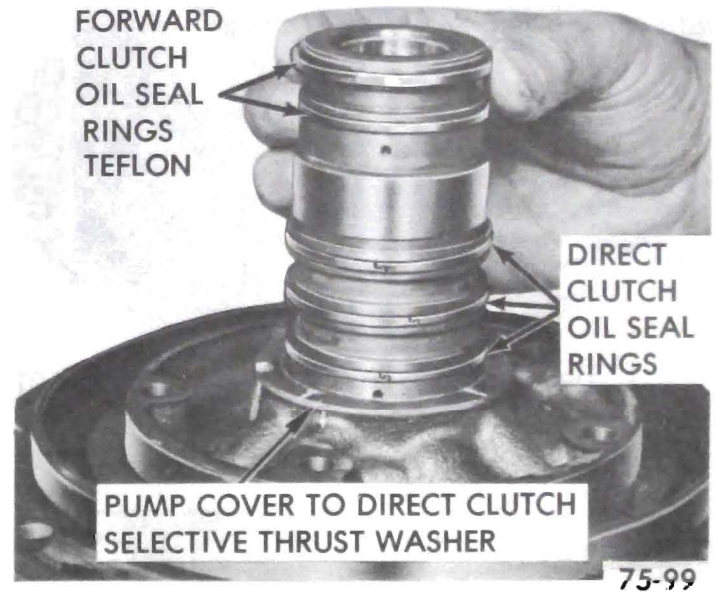

Figure 75-135

5. Remove pump cover and stator shaft assembly from pump body. See Figure 75-136.

6. Remove pump drive gear and driven gear from pump body. See Figure 75-137.

7. Fill cooler by-pass passage with grease and insert Tool J-23134 and force by-pass valve seat, check ball, and spring from pump body. See Figure 75-139.



PUMP COVER AND STATOR SHAFT ASSEMBLY

PUMP BODY



75-100

Figure 75-136

DRIVEN GEAR

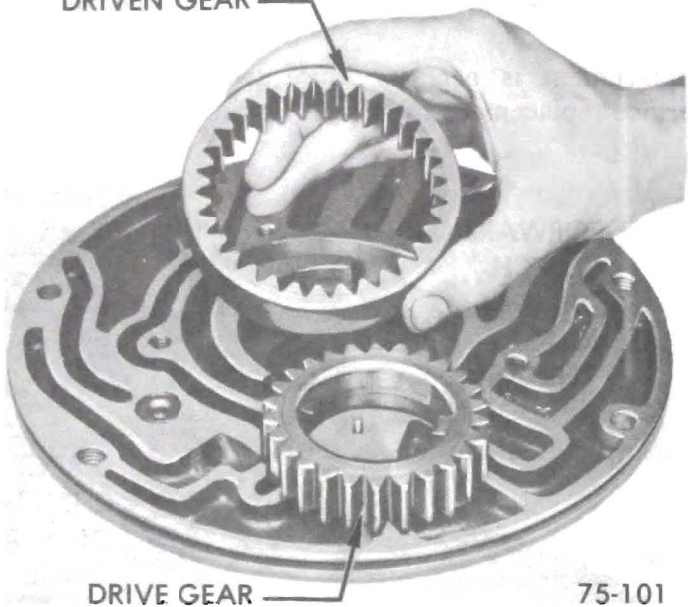

DRIVE GEAR

75-101

Figure 75-137

PUMP BODY

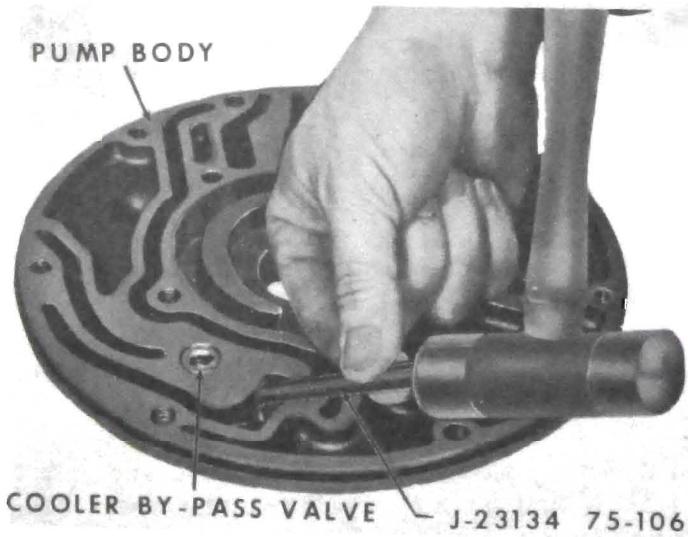

COOLER BY-PASS VALVE

J-23134 75-106

Figure 75-139

8. Remove pump outside diameter to case square cut "O" ring seal and discard. See Figure 75-140.

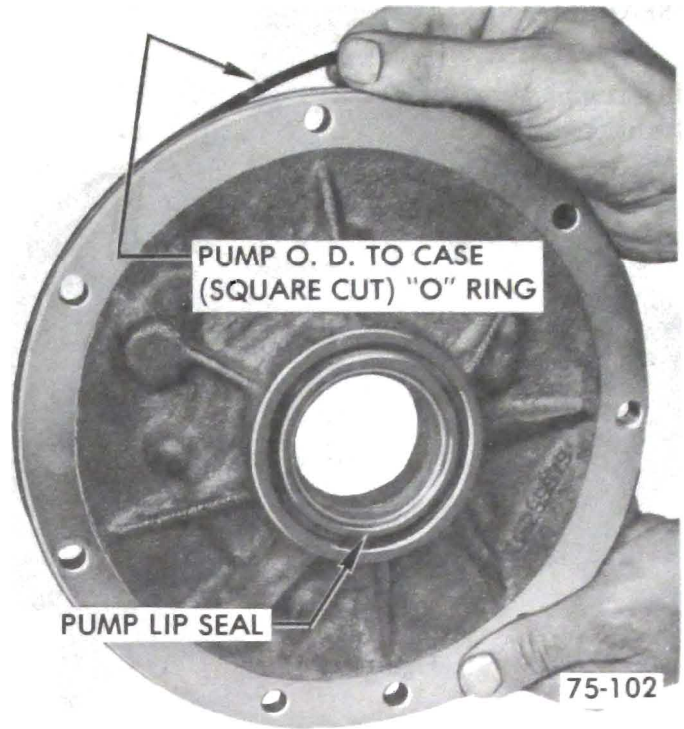

PUMP O. D. TO CASE (SQUARE CUT) "O" RING

PUMP LIP SEAL

75-102

Figure 75-140

9. Remove pump body to converter hub lip seal, if necessary and discard. See Figure 75-141.

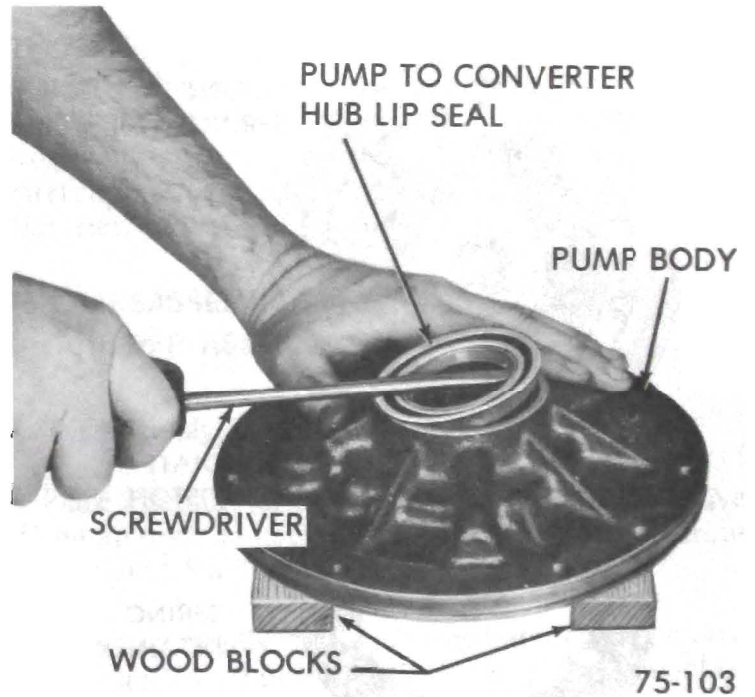

PUMP TO CONVERTER HUB LIP SEAL

PUMP BODY

SCREWDRIVER

WOOD BLOCKS

75-103

Figure 75-141

10. Place pump on wood blocks so surface finish is not damaged and install pump to converter hub lip seal using Seal Driver J-21359. See Figure 75-142. Make certain lip seal is not turn or nicked.

11. Check oil pump bushing for nicks severe scoring or

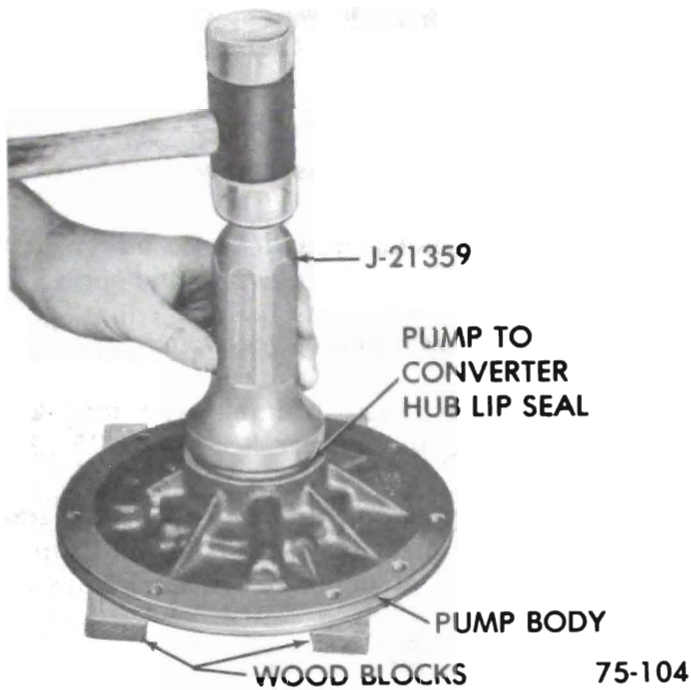

Figure 75-142

wear. If bushing replacement is necessary remove as follows: support pump on wood blocks. Use Tool J-21465-17 and Drive Handle J-8092 press bushing out of pump body. To install new oil pump bushing use Tool J-21465-17 and Drive Handle J-8092 and press bushing into pump body from gear pocket face until it is flush to .010" below opposite face. (Front Pump Seal Side). See Figure 75-143.

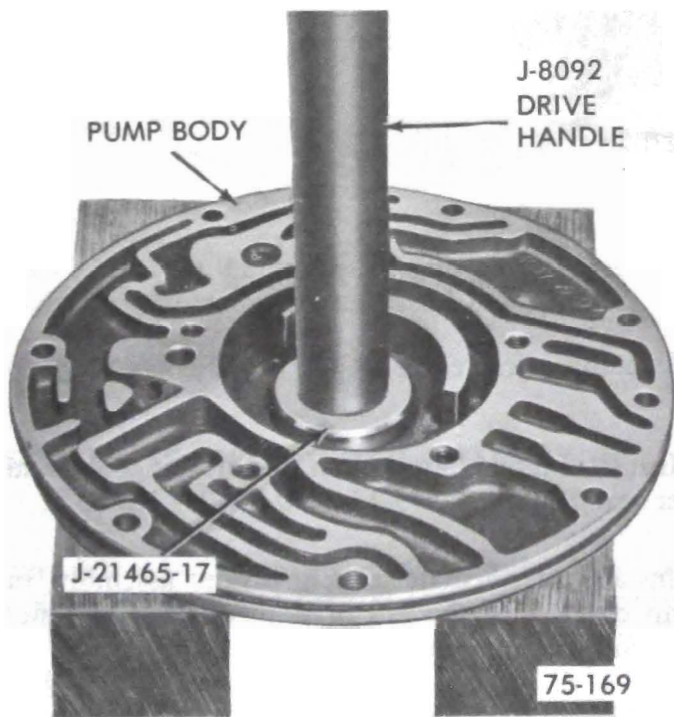
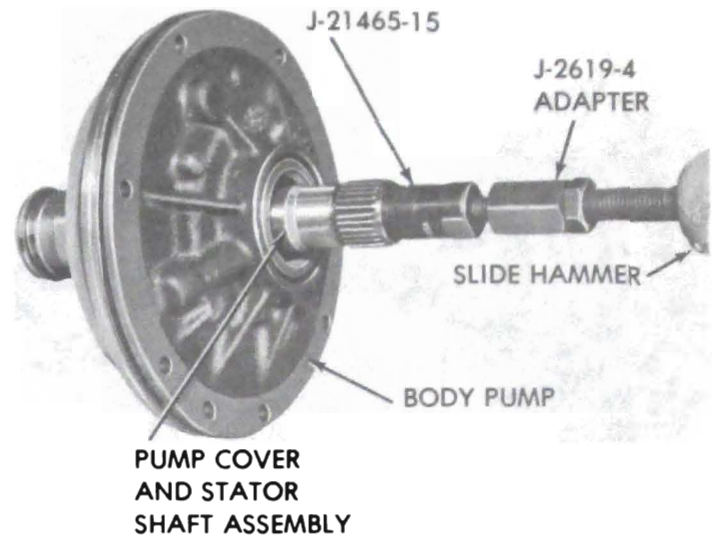

Figure 75-143

12. Check front stator shaft bushing for nicks, severe scoring or wear. If bushing replacement is necessary remove as follows: Assemble bushing remover

J-21465-15 to adapter J-2619-4. Assemble this assembly to Slide Hammer J-2619. Clamp Slide Hammer into vise. Grasp stator shaft and remove bushing. See Figure 75-144.



75-170

Figure 75-144

13. Install front stator shaft bushing as follows: Support pump assembly on J-21424-7 before installing bushing. Install bushing into the front end of stator shaft. Using Installer J-21424-7 and Drive Handle J-8092 tap bushing into shaft to 1/4 inch below top of stator shaft. See Figure 75-145. Extreme care must be taken so bushing is not driven past shoulder.

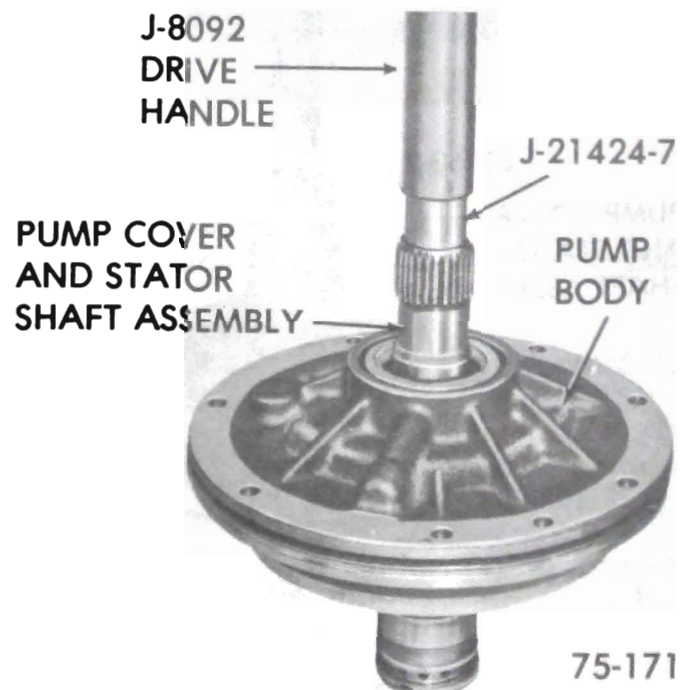

75-171

Figure 75-145



14. If replacement of lower rear stator shaft bushing is required, proceed as follows: Thread Tool J-21465-15 into stator shaft lower rear bushing. Thread Slide Hammer J-2619 into remover. Clamp slide hammer into vise. Grasp stator shaft and remove bushing. See Figure 75-146. If upper rear stator shaft bushing is required, repeat above procedure.

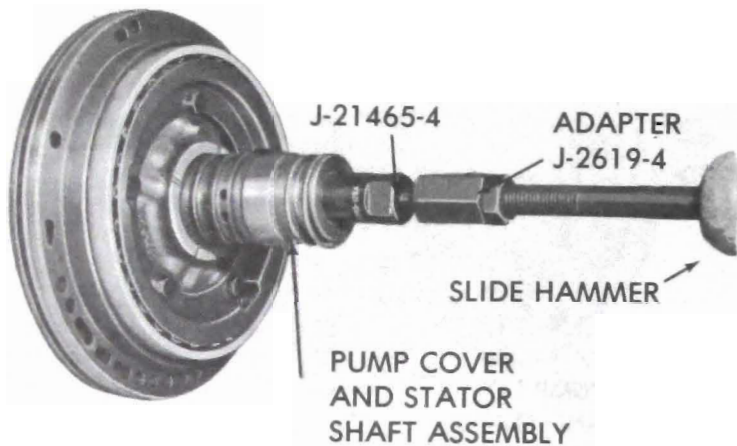

75-172

Figure 75-146

Using Tool J-23062-2 press upper rear stator shaft bushing 1-1/32 inch below top surface of oil pump delivery sleeve. See Figure 75-147.

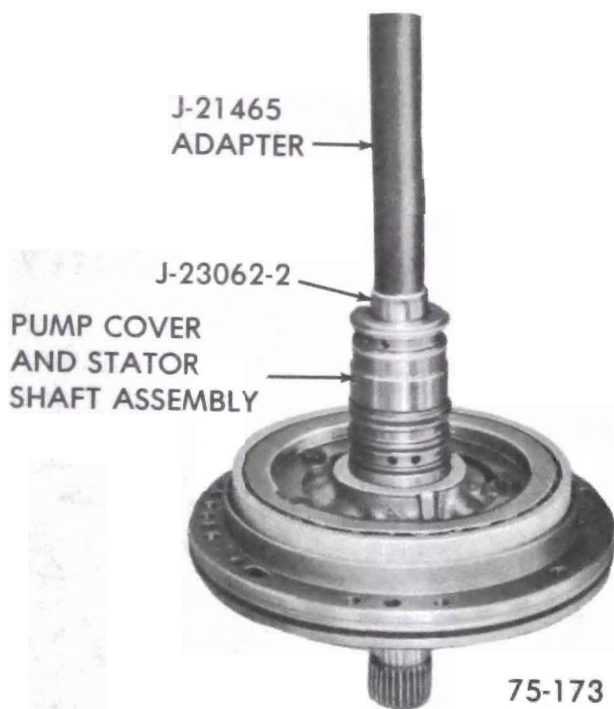

75-173

Figure 75-147

Using Tool J-23062-2 press lower rear stator shaft bushing flush to .010" below chamfer on oil pump delivery sleeve.

### B. Reassembly of Oil Pump Assembly

If the pump body is damaged and has to be replaced, the service part requires a priming valve and spring.

1. Install pump drive gear and driven gear.

Drive gear has off-set tangs, assemble with tang face up to prevent damage to converter. See Figure 75-137.

2. Install cooler by-pass spring, check ball and seat. Using Tool J-23112, press seat into bore until top of seat is flush with face of pump body. See Figure 75-151.

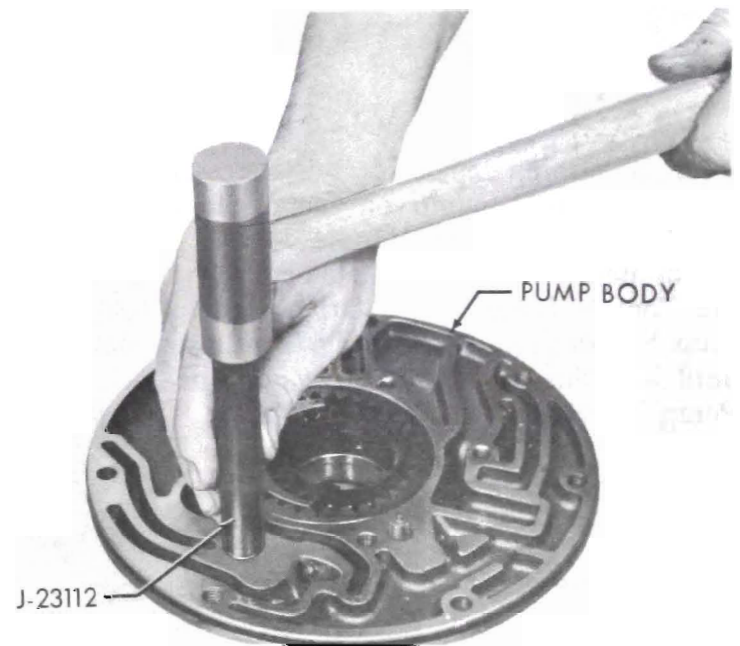

75-175

Figure 75-151

3. Assemble pump cover to pump body. See Figure 75-136.

4. Install intermediate clutch piston inner seal and outer seal. See Figure 75-134.

5. Install intermediate clutch piston assembly into pump cover with the aid of a piece of .020" music wire crimped into copper tubing.

6. Install twenty (20) release springs. See Figure 75-133.

7. Install spring retainer and install five (5) attaching bolts, finger tight. See Figure 75-132.

8. Place pump aligning strap, J-21368 over pump body and cover and tighten.



9. Tighten attaching bolts. Torque to 18 lb.ft.

10. Install pump outside diameter to case (square cut) "O" ring seal. See Figure 75-140. Use new square cut "O" ring seal.

11. Install three (3) direct clutch to pump hub hook type oil seal rings. Inspect two (2) forward clutch to pump hub teflon oil seal rings, for service if rings require replacement use hook type cast iron rings. See Figure 75-135.

12. Install direct clutch drum housing to pump cover selective thrust washer over pump cover delivery sleeve. See Figure 75-158.



Figure 75-158

Check three (3) pump cover hub lube holes. Make certain they are not restricted. See Figure 75-159.



Figure 75-159

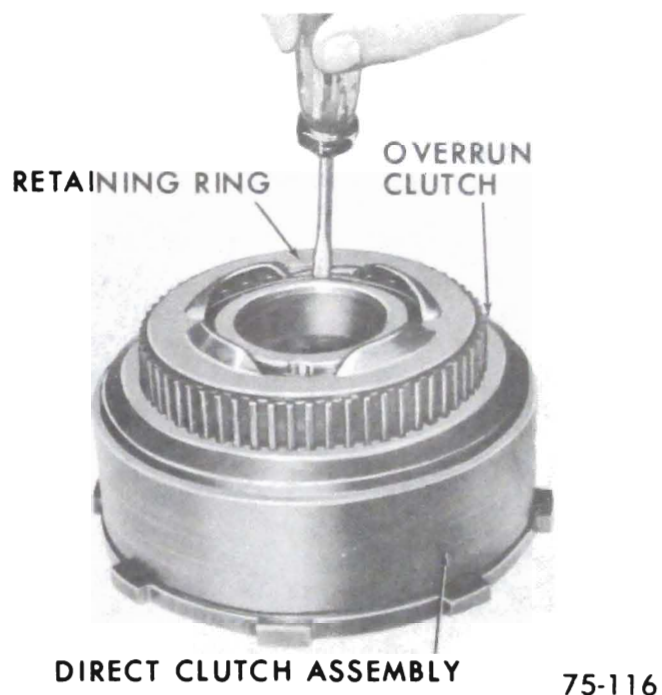

Figure 75-160

## 75-28 DISASSEMBLY AND REASSEMBLY OF DIRECT CLUTCH

There is one additional clutch plate in the direct clutch of KL-375B Models. Take note that when replacing clutch pack or piston, specific part numbers for 375B transmission must be used.

### A. Disassembly of Direct Clutch

1. Remove intermediate overrun clutch front retainer ring and retainer. See Figure 75-160.
2. Remove intermediate clutch overrun outer race. See Figure 75-161.

3. Remove intermediate overrun roller clutch assembly. See Figure 75-162.

4. Remove direct clutch drum to forward clutch housing needle roller bearing. See Figure 75-163.

5. Remove direct clutch pressure plate to clutch drum retaining ring and pressure plate. See Figure 75-164.

6. Remove four (4) lined and four (4) steel plates from direct clutch housing (five (5) each in KL-375B Models). See Figure 75-165.

7. Inspect condition of lined and steel plates. *Do not diagnose a lined drive plate by color.*

INTERMEDIATE OVERRUN  
ROLLER OUTER RACE



Figure 75-161

75-117

DIRECT CLUTCH DRUM TO  
FORWARD CLUTCH HOUSING  
NEEDLE ROLLER BEARING

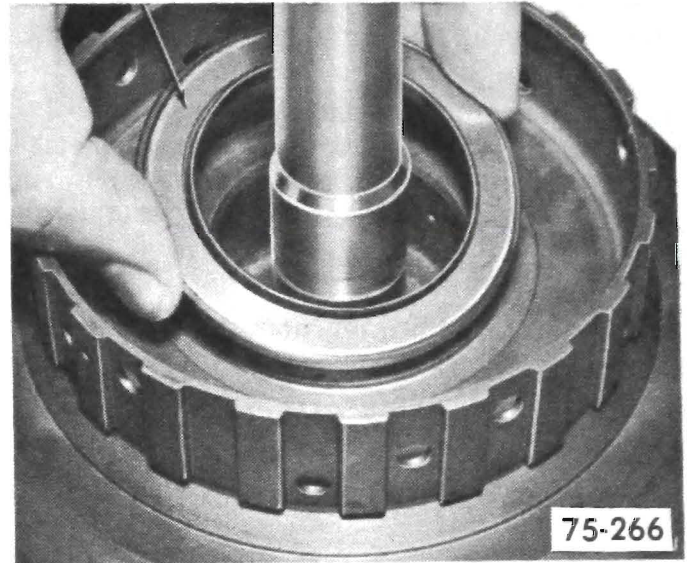

Figure 75-163

75-266

INTERMEDIATE OVERRUN  
ROLLER CLUTCH ASSEMBLY

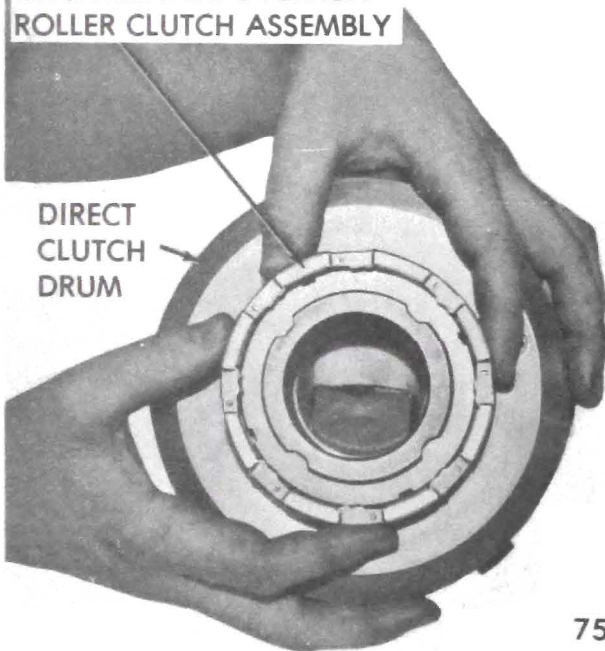

Figure 75-162

75-118

RETAINING RING  
PRESSURE PLATE  
DIRECT CLUTCH DRUM

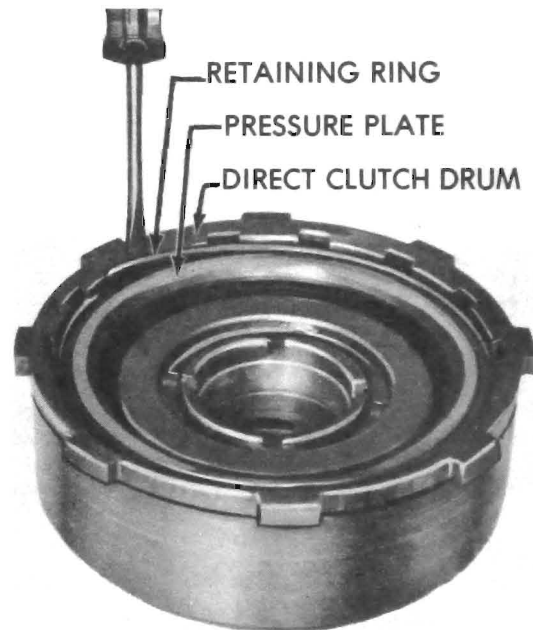

Figure 75-164

75-121

A. Dry lined plates with compressed air and inspect the lined surfaces for:

1. Pitting and flaking
2. Wear
3. Glazing
4. Cracking
5. Charring
6. Chips or metal particles imbedded in lining

If a lined drive plate exhibits any of the above conditions, replacement is required.

CUSHION SPRING  
STEEL PLATES

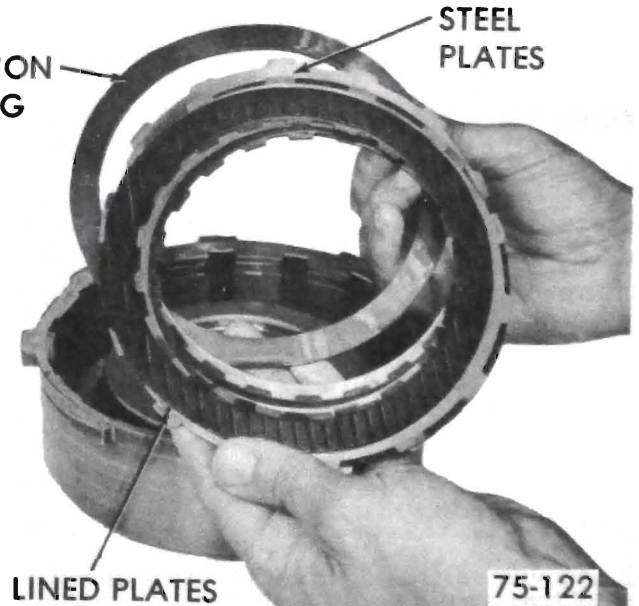

Figure 75-165

LINED PLATES

75-122



B. Wipe steel plates dry and check for heat discoloration. If the surface is smooth and an even color smear is indicated, the plates should be reused. If severe heat spot discoloration or surface scuffing is indicated, the plates must be replaced.

8. Remove direct clutch piston return spring seat retaining ring and spring seat by using Tools J-2590-3, J-2590-5, and snap ring pliers. See Figure 75-166.

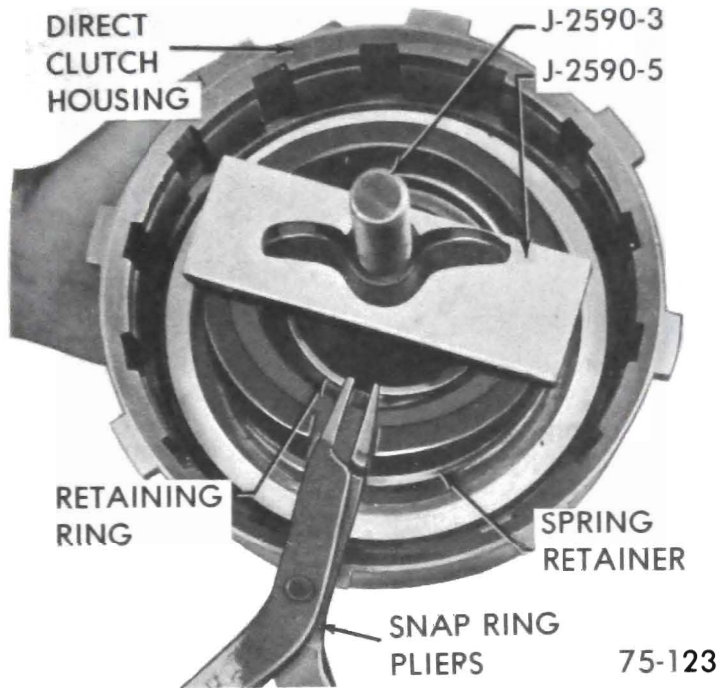

Figure 75-166

9. Remove seventeen (17) clutch return coil springs and piston. See Figure 75-167.

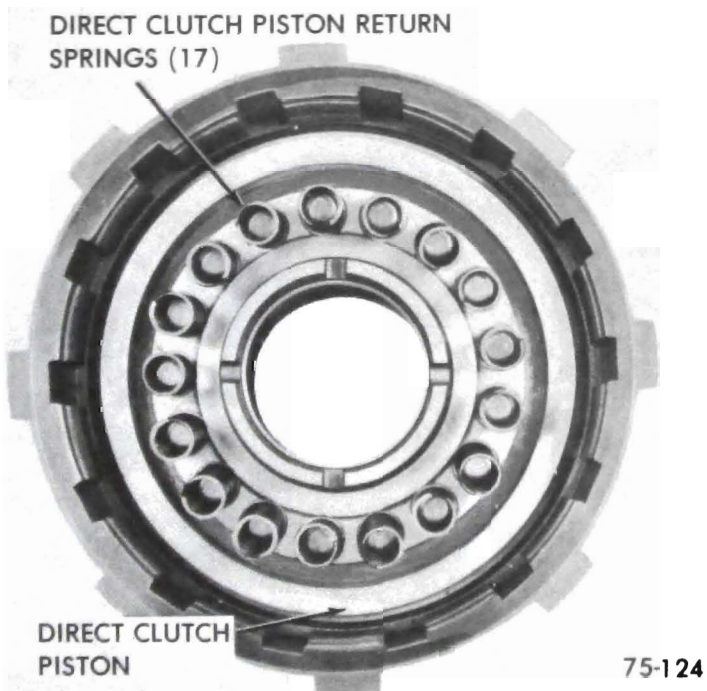

Figure 75-167

10. Inspect the return springs. Evidence of extreme heat or burning in the area of the clutch may have caused the springs to take a heat set and would justify replacement of the springs.

11. Remove direct clutch piston inner and outer seals. See Figure 75-168.

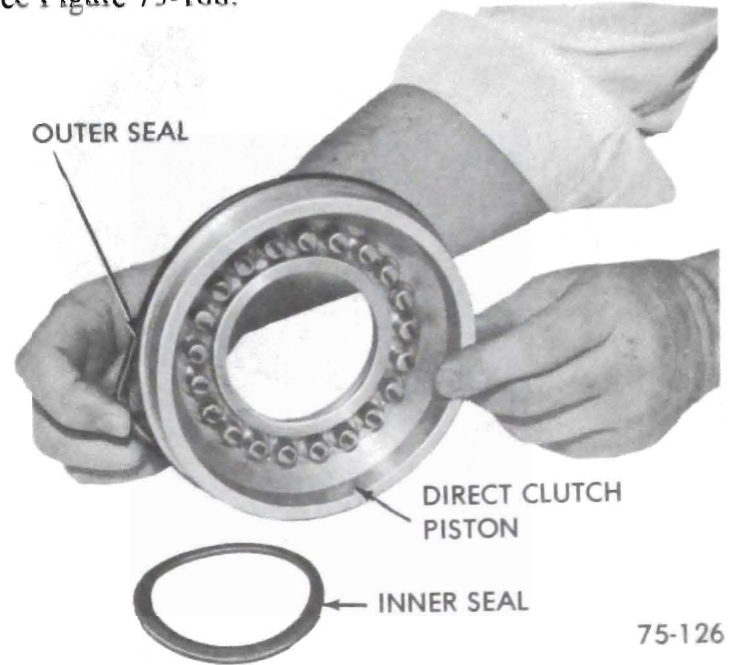

Figure 75-168

12. Remove direct clutch piston center seal. See Figure 75-169.

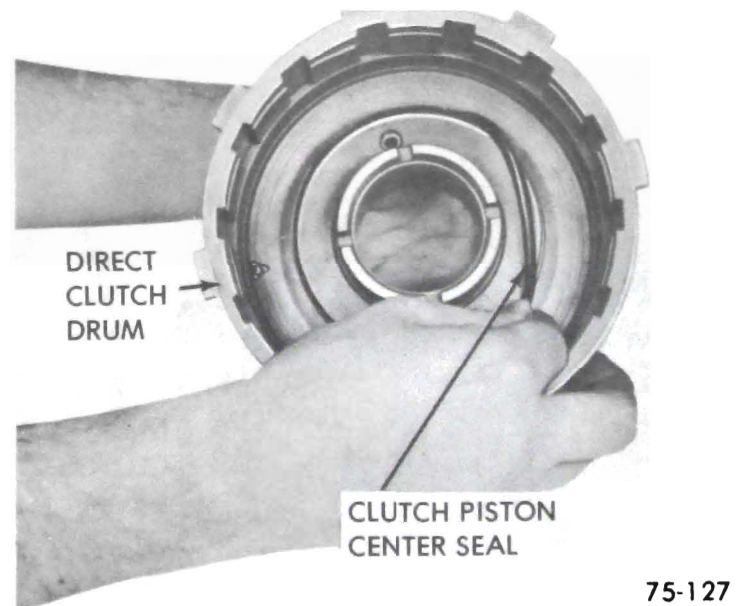

Figure 75-169

13. If bushing replacement is necessary, use a Cape



Chisel and remove bushing using care not to score inner surface of direct clutch drum. See Figure 75-170.

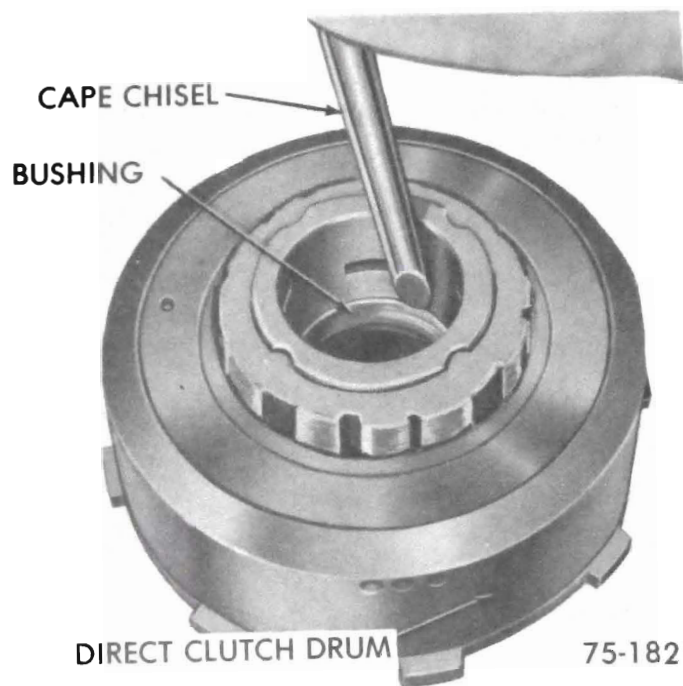

Figure 75-170

14. Install direct clutch bushing using Tool J-23062-4, Drive Handle J-8092, and install .010" below slot in retainer hub. See Figure 75-171.

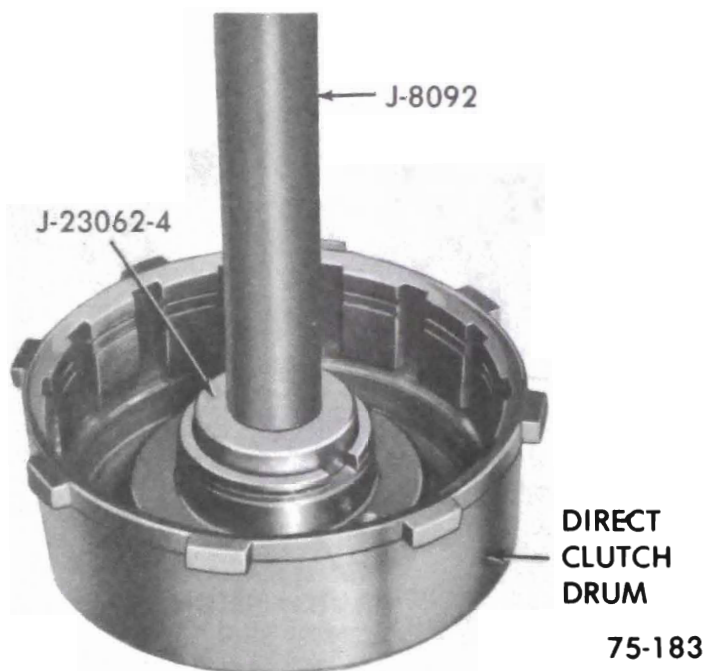

Figure 75-171

**B. Reassembly of Direct Clutch**

1. Install the direct clutch piston outer seal and inner seal. See Figure 75-168.

2. Install direct clutch piston center seal. See Figure 75-169.

3. Install the direct clutch piston into housing with the aid of a piece of .020" music wire crimped into copper tubing. See Figure 75-174.

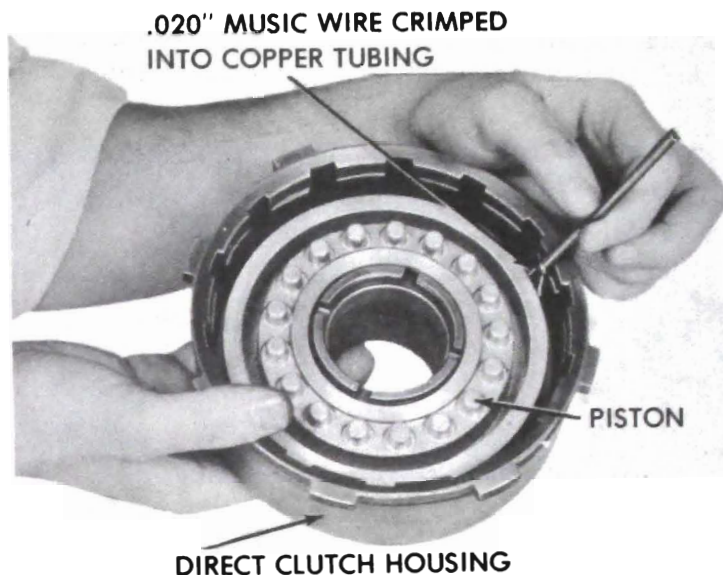

75-125

Figure 75-174

4. Install seventeen (17) clutch return coil springs. See Figure 75-167. Return springs are violet in color.

5. Install spring retainer. Compress spring retainer and install retaining ring, using Tools J-2590-3 and J-2590-5. See Figure 75-166.

6. Lubricate with transmission fluid and install four (4) faced plates and four (4) steel separator plates starting with a steel plate and alternating steel and faced (five (5) each in KL-375B Models). See Figure 75-177.

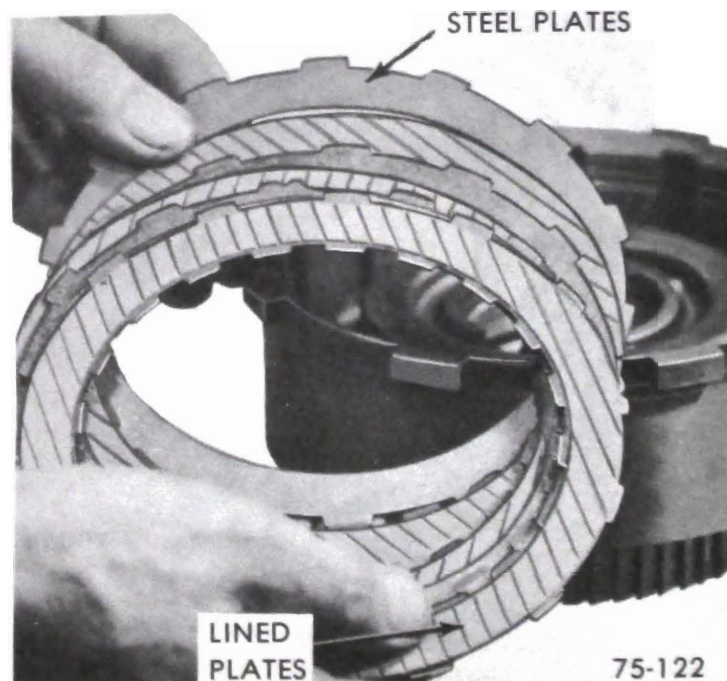

75-122

Figure 75-177

7. Install direct clutch pressure plate and retaining ring. See Figure 75-164.

8. Install intermediate overrun roller clutch assembly. See Figure 75-162.

Roller clutch assembly must be assembled with two (2) holes down (toward rear of transmission).

9. Install intermediate clutch overrun outer race. See Figure 75-161.

When the intermediate overrun clutch outer race is installed, it should free wheel in the counterclockwise direction only.

10. Install intermediate overrun clutch retainer, and retaining ring. See Figure 75-160.

## 75-29 DISASSEMBLY AND REASSEMBLY OF FORWARD CLUTCH ASSEMBLY

### A. Disassembly of Forward Clutch

1. Remove forward clutch drum to pressure plate retaining ring.

Remove forward clutch pressure plate. See Figure 75-184.

2. Remove five (5) forward clutch housing faced plates, five (5) steel plates and cushion spring. See Figure 75-185.

3. Inspect condition of lined and steel plates. *Do not diagnose a lined drive plate by color.*

A. Dry lined plates with compressed air and inspect the lined surfaces for:

1. Pitting and flaking
2. Wear
3. Glazing
4. Cracking
5. Charring
6. Chips or metal particles imbedded in lining

If a lined drive plate exhibits any of the above conditions, replacement is required.

B. Wipe steel plates dry and check for heat discoloration. If the surface is smooth and an even color smear is indicated, the plates should be reused. If severe heat spot discoloration or surface scuffing is indicated, the plates must be replaced.

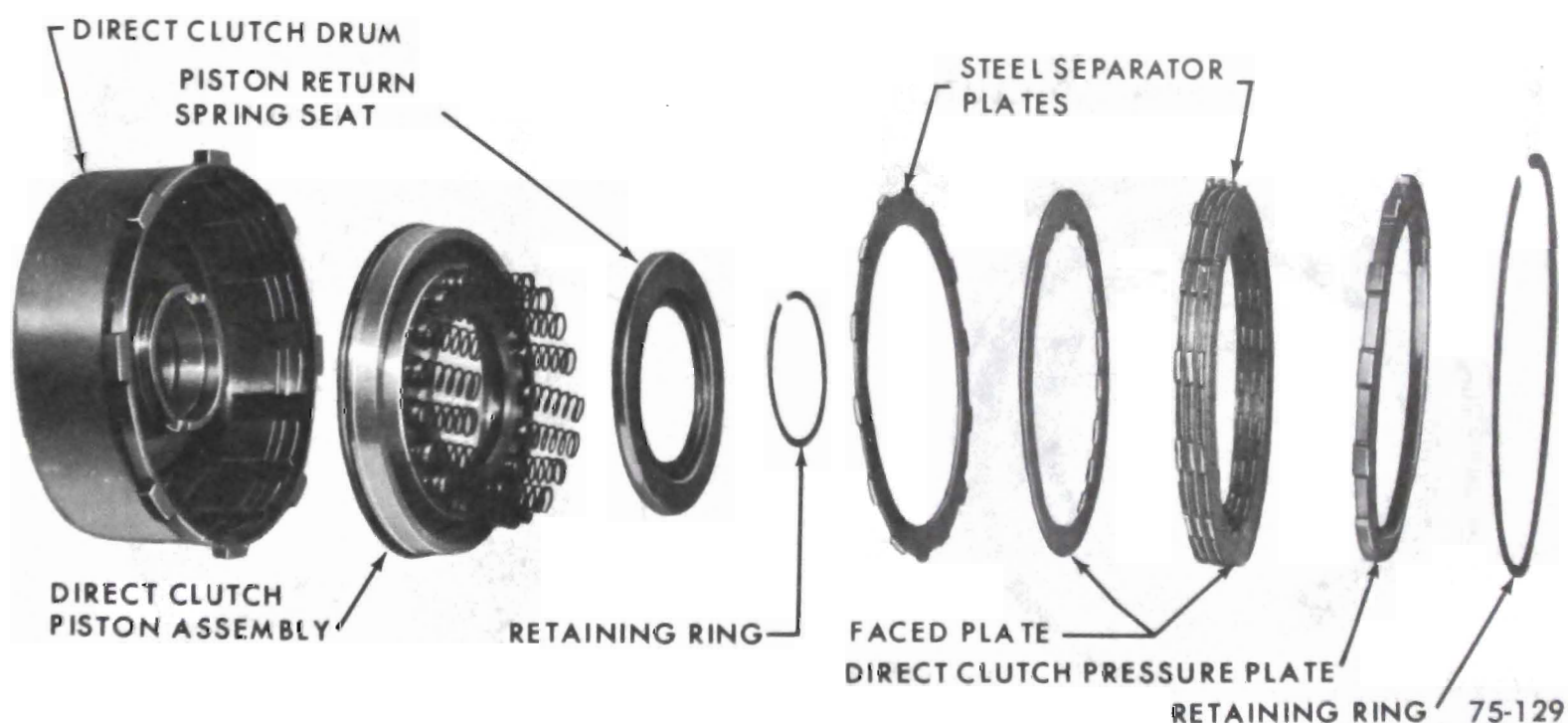

Figure 75-182 - Direct Clutch Assembly - Exploded View



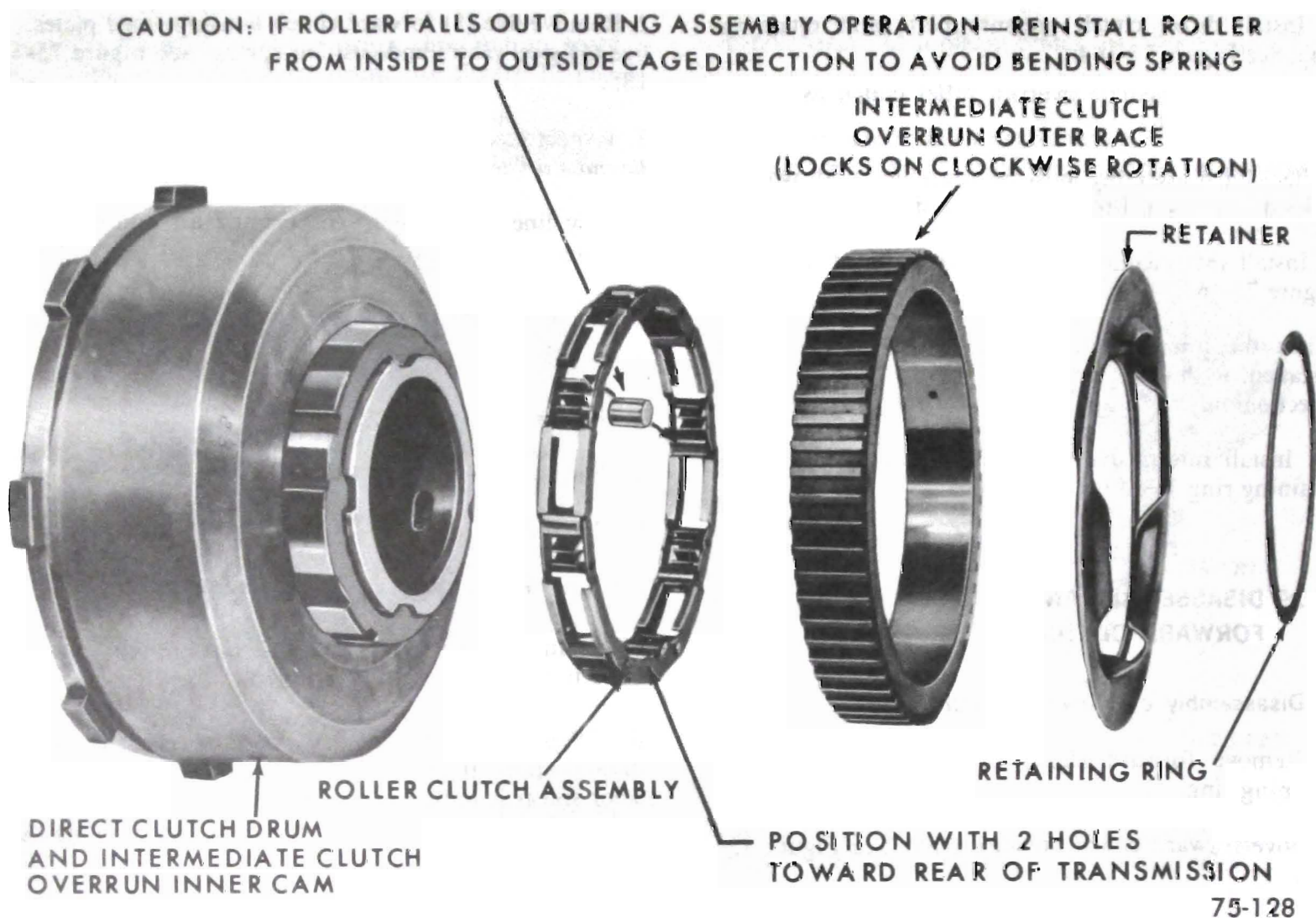

Figure 75-183 - Intermediate Overrun Roller Clutch Assembly

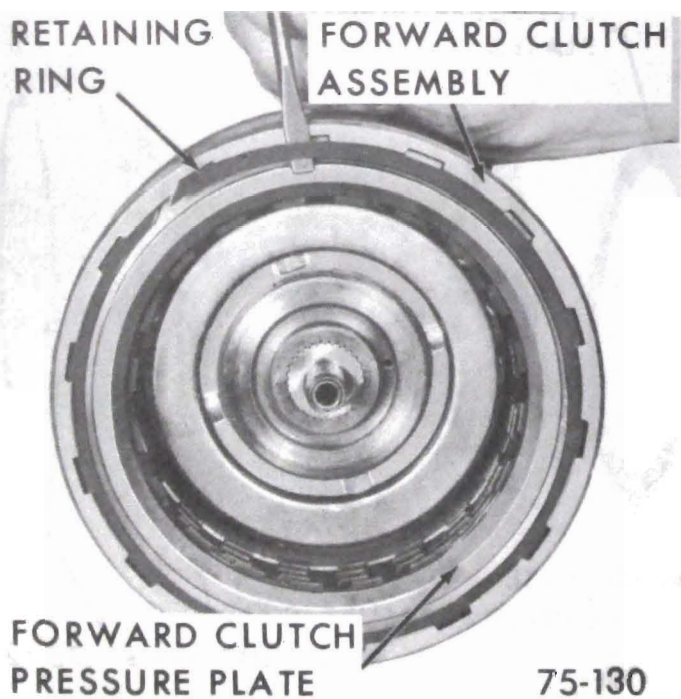

Figure 75-184

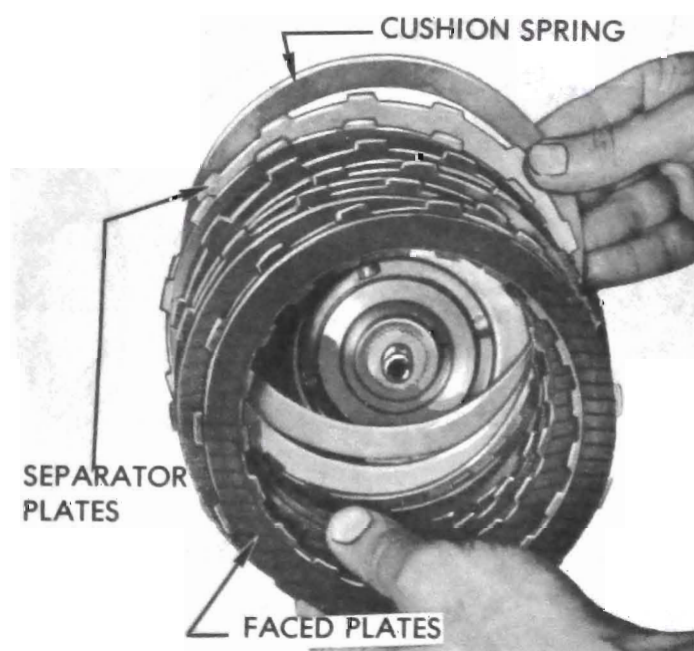

Figure 75-185



4. Remove spring retainer by compressing with a ram press. See Figure 75-186.

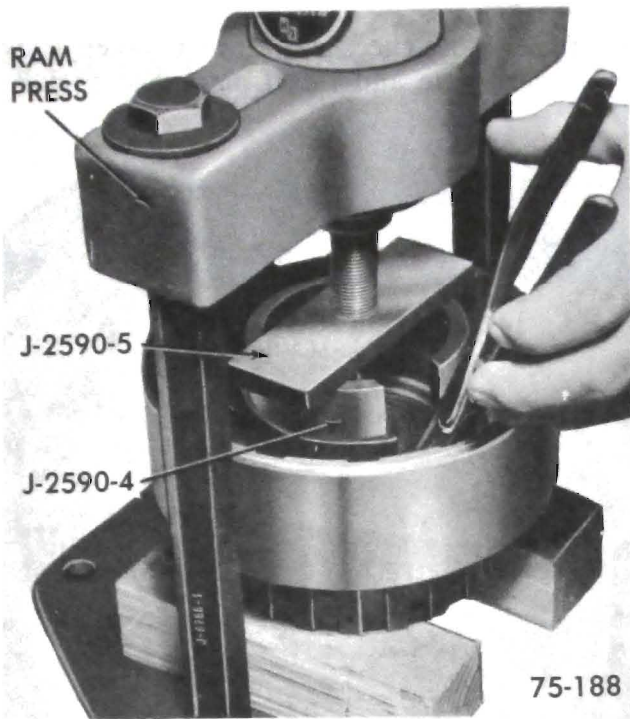

Figure 75-186

5. Remove twenty-one (21) clutch return coil springs. See Figure 75-187.

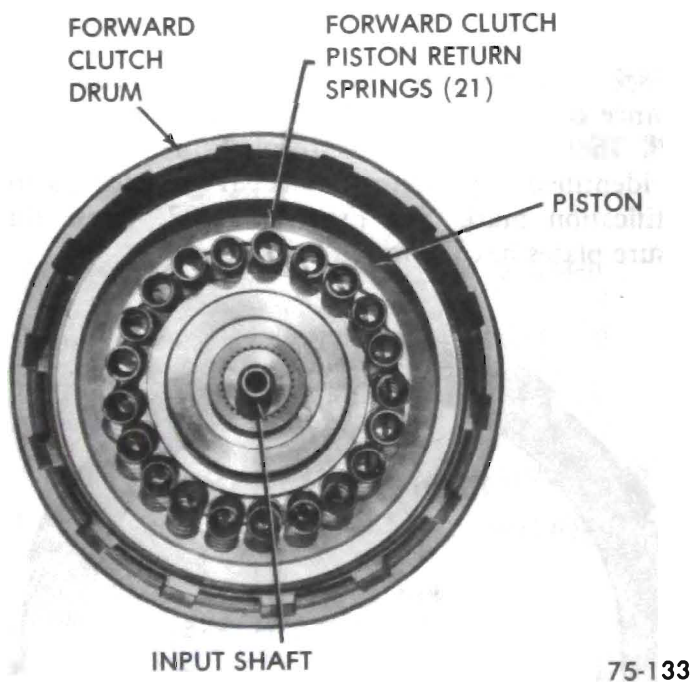

Figure 75-187

6. Inspect the return springs. Evidence of extreme heat or burning in the area of the clutch may have caused the springs to take a heat set and would justify replacement of the springs.

7. Remove forward clutch piston assembly. See Figure 75-188.

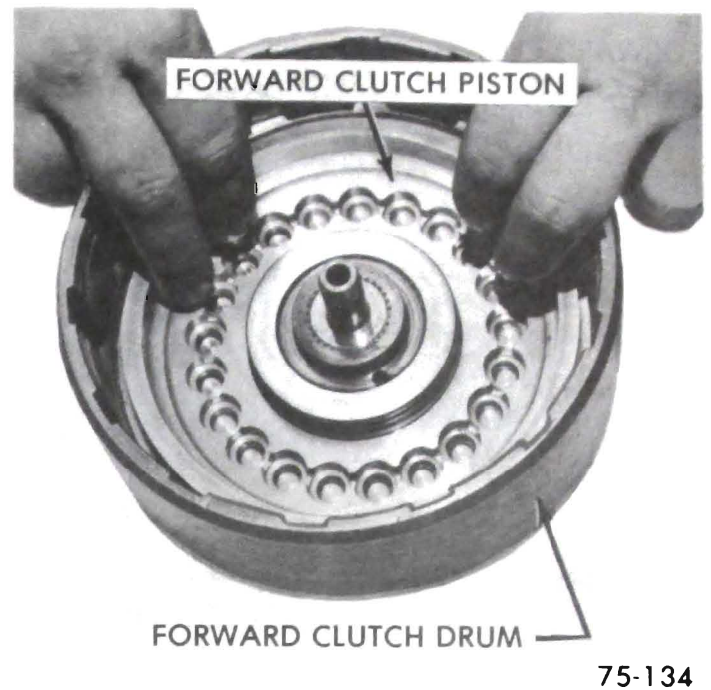

Figure 75-188

8. Remove forward clutch piston inner and outer seals. See Figure 75-189.

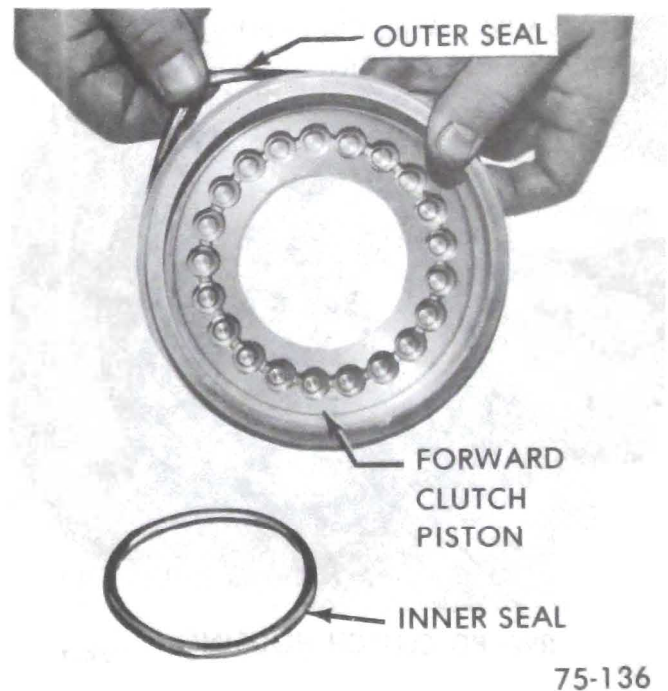

Figure 75-189

9. Make certain forward clutch ball check exhaust is free of dirt, etc. See Figure 75-190.

### B. Reassembly of Forward Clutch Assembly

1. Install the forward clutch inner piston seal and outer piston seal. See Figure 75-189.

2. Install the forward clutch piston assembly with aid

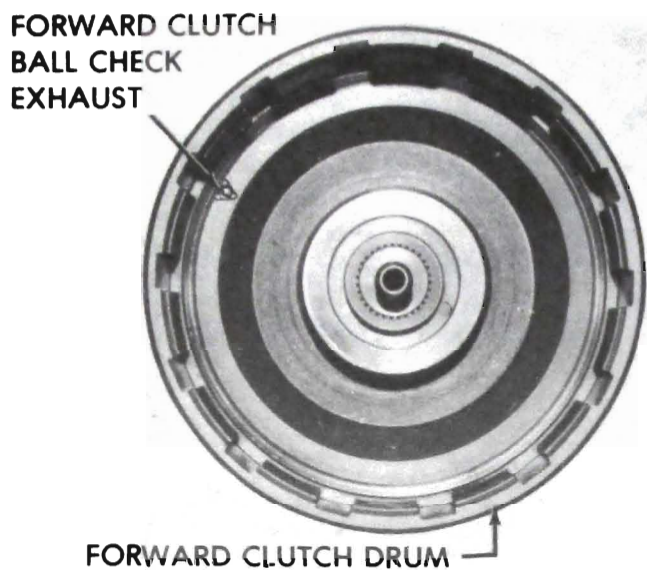

75-137

Figure 75-190

of a piece of .020" music wire crimped into copper tubing. See Figure 75-192.

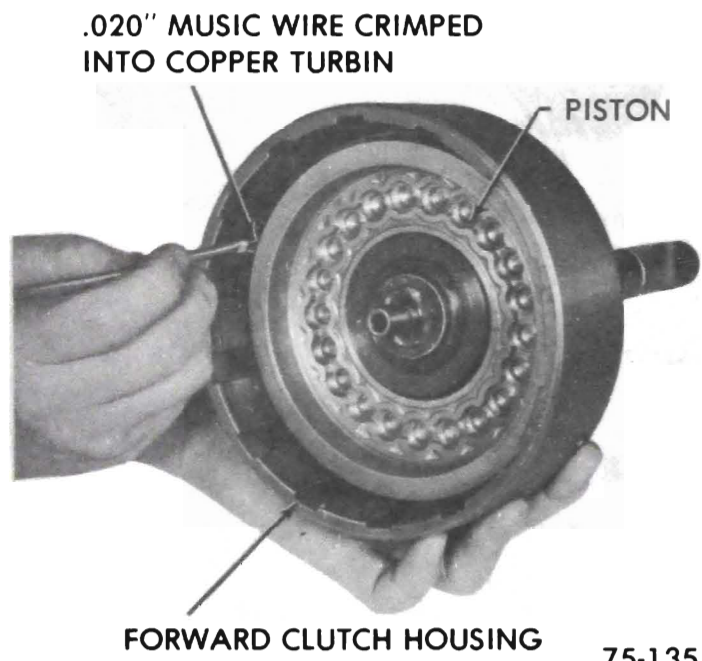

75-135

Figure 75-192

3. Install twenty-one (21) clutch return coil springs. See Figure 75-187. Return springs are violet in color.

4. Install spring retainer. Compress spring retainer with an arbor press or ram press. See Figure 75-186.

5. Lubricate with transmission fluid and install cushion spring, five (5) faced plates and five (5) steel separator plates, starting with the cushion spring and alternating steel and faced. See Figure 75-185. Forward clutch cushion spring is plain (not color coded).

6. Install forward clutch pressure plate and retaining ring. See Figure 75-184.

Using a feeler gage check clearance between forward clutch pressure plate and faced plate. See Figure 75-196.

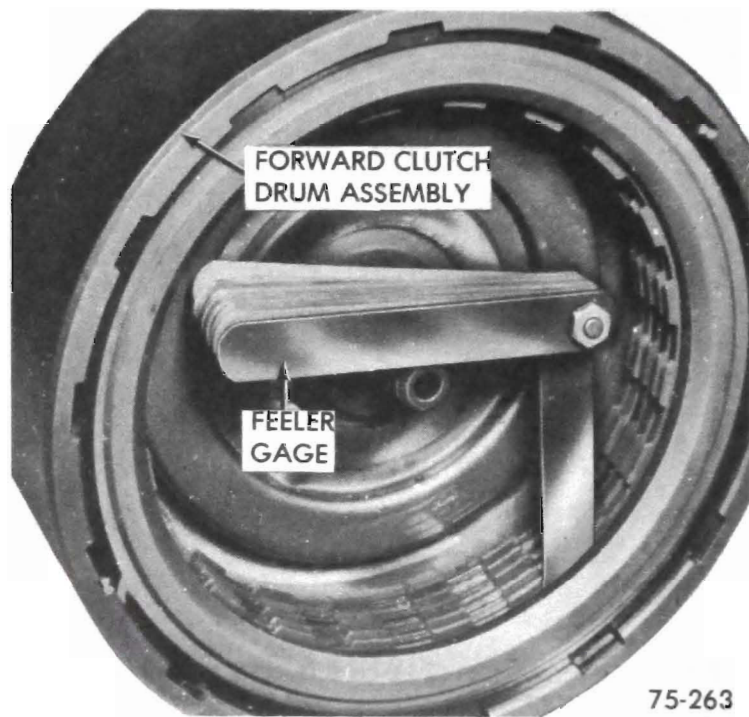

75-263

Figure 75-196

The specifications for this transmission call for a clearance of no less than .0105" and no greater than .082". There are three pressure plates available which are identified by tangs adjacent to the source identification mark. See Figure 75-197. These three pressure plates have different thicknesses.

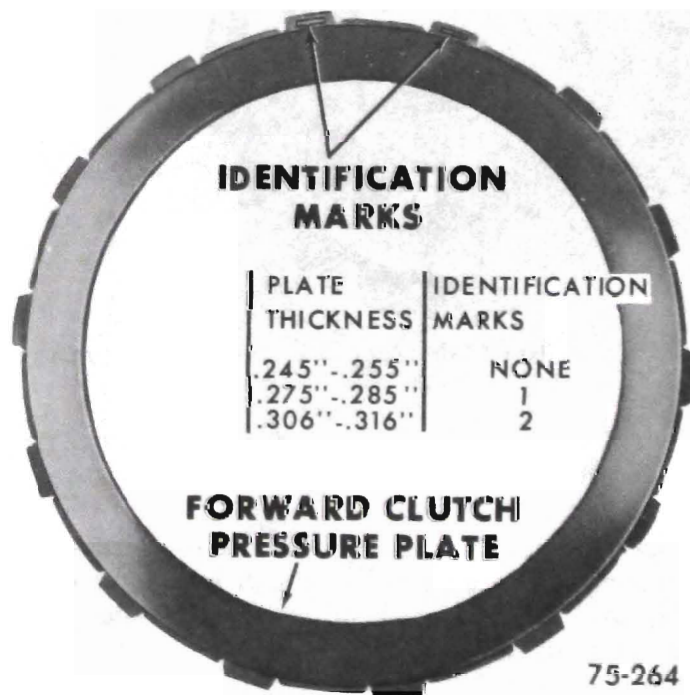

75-264

Figure 75-197



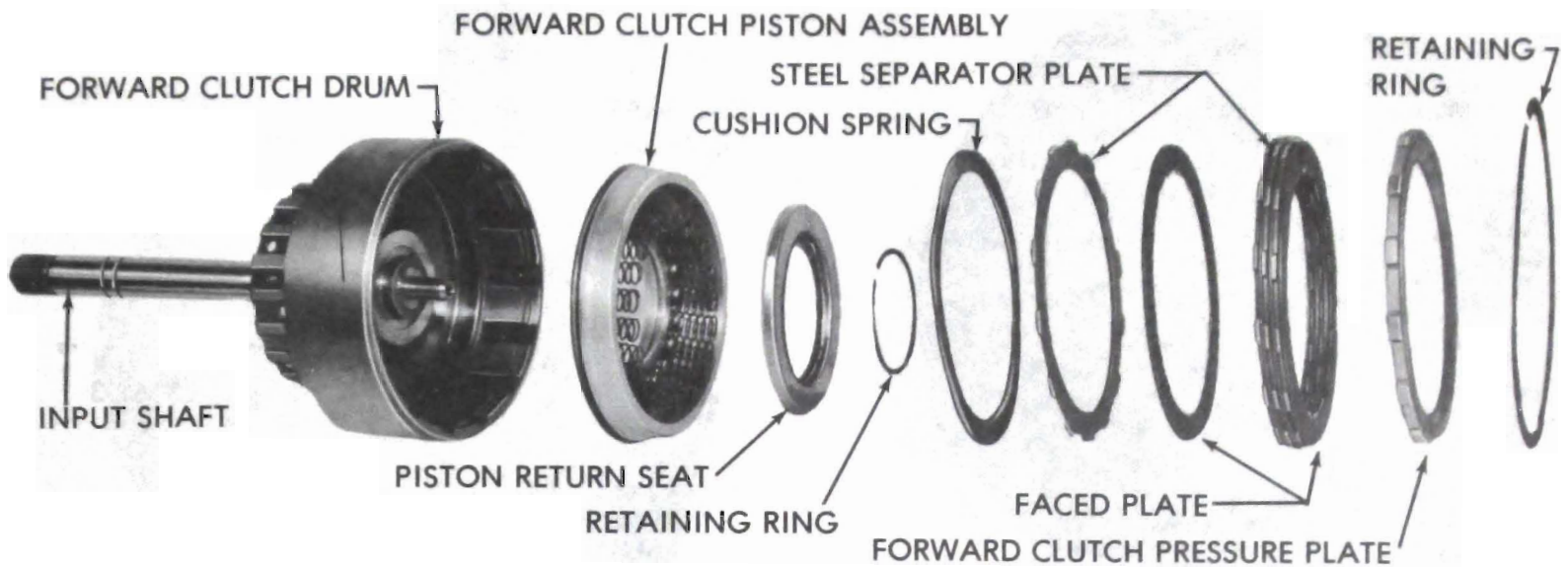

Figure 75-199 - Forward Clutch Assembly Exploded View

plate should be used to have a clearance between .0105" and .082". If the clearance checks out to be between .0105" and .082", no change of pressure plate is necessary.

If the clearance between the forward clutch pressure plate and the faced plate checks out to be less than .0105", a thinner pressure plate should be used to have a clearance between .0105" and .082". If the clearance checks out to be greater than .082", a thicker pressure

### 75-30 DISASSEMBLY AND REASSEMBLY OF SUN GEAR TO DRIVE SHELL

#### A. Disassembly of Sun Gear to Drive Shell

1. Remove sun gear to sun gear drive shell rear retaining ring. See Figure 75-200.



Figure 75-200

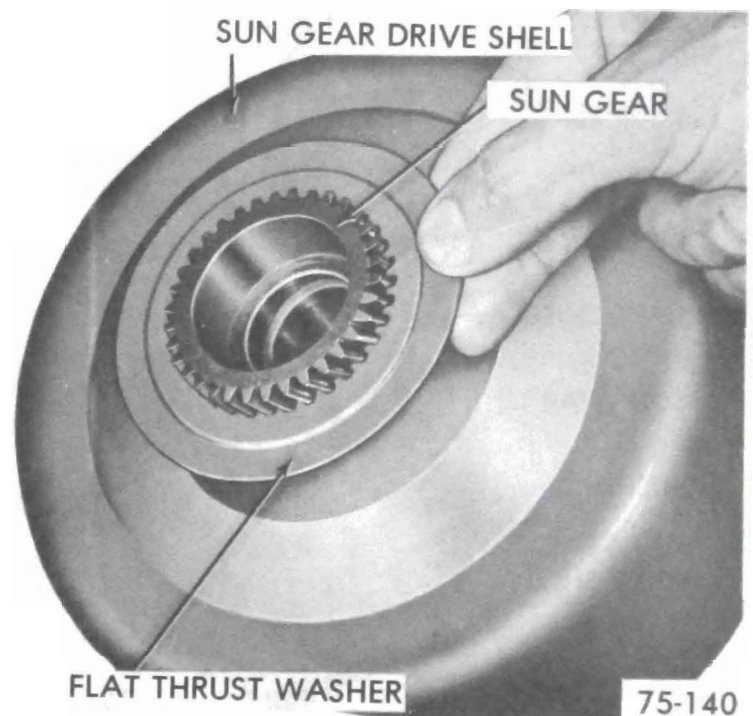

Figure 75-201

2. Remove sun gear to drive shell flat rear thrust washer. See Figure 75-201.

3. Remove front retaining ring from sun gear. See Figure 75-202.

If sun gear bushings replacement are necessary, remove with a cape chisel. See Figure 75-203.

Install sun gear bushings using Tool J-23062-3, J-8092 and install flush to .010" below counterbores. See Figure 75-204.



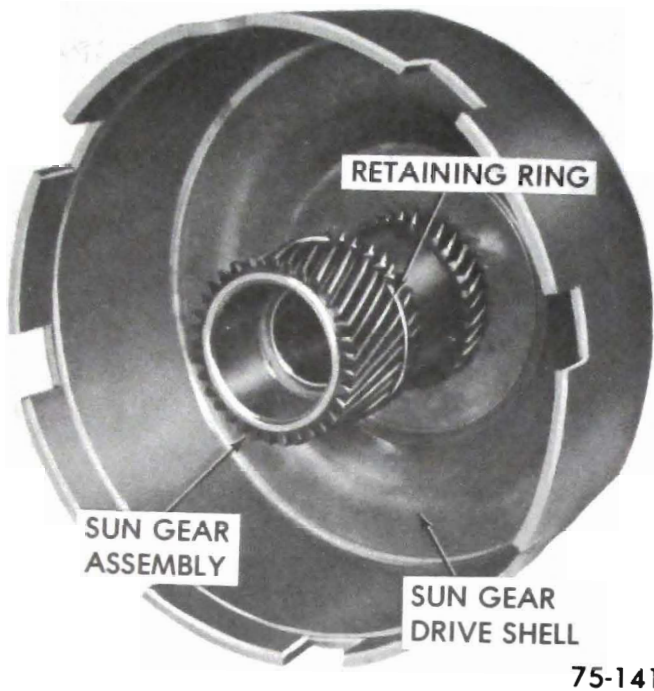

Figure 75-202

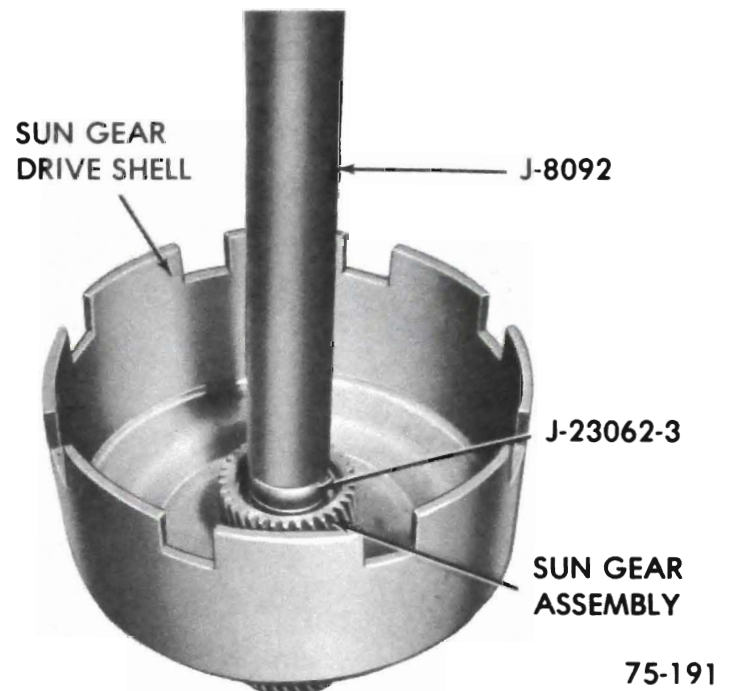

Figure 75-204 - Bushing Installation

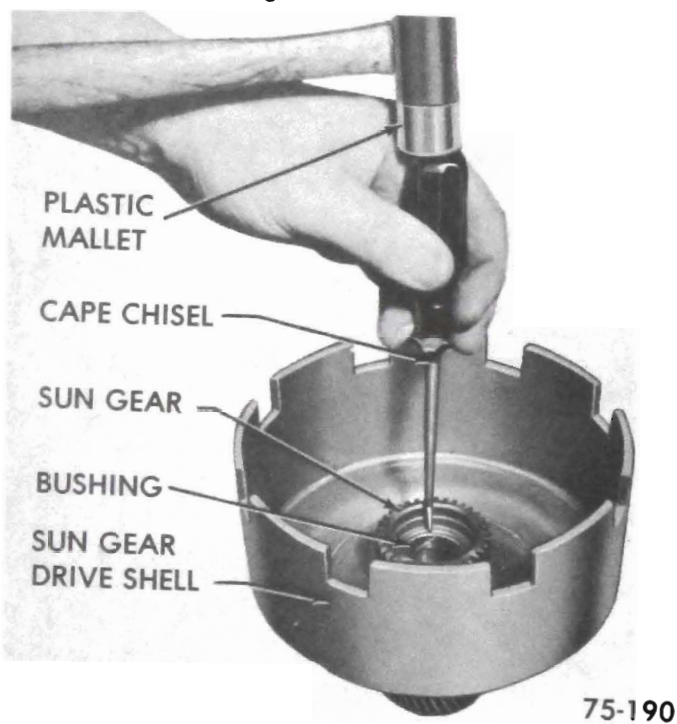

Figure 75-203

**75-31 DISASSEMBLY AND REASSEMBLY OF LOW AND REVERSE ROLLER CLUTCH ASSEMBLY**

**A. Disassembly of Low and Reverse Roller Clutch Assembly**

1. Remove low and reverse clutch to sun gear shell thrust washer. See Figure 75-208.



Figure 75-208

**B. Reassembly of Sun Gear to Drive Shell**

1. Install sun gear to drive shell front retaining ring, and install into drive shell. See Figure 75-202. Use a new ring and do not overstress when installing.

2. Install sun gear to drive shell flat thrust washer. See Figure 75-201.

3. Install sun gear to sun gear drive shell rear retaining ring. See Figure 75-200. Use a new ring and do not overstress when installing.

2. Remove low and reverse overrun clutch inner race. See Figure 75-209.

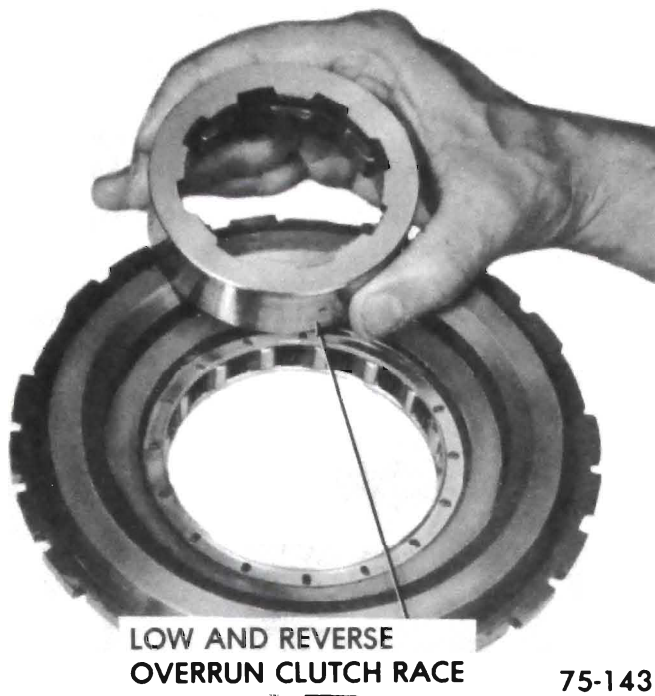

Figure 75-209

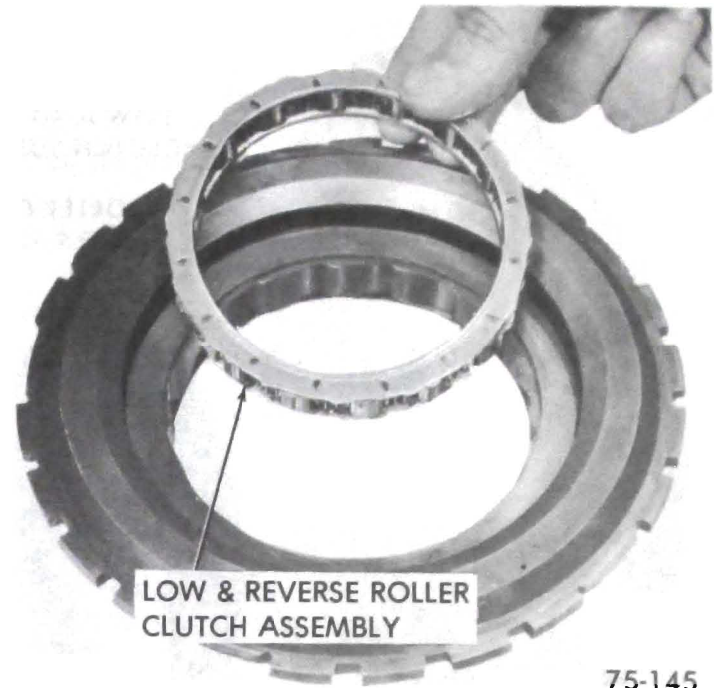

Figure 75-211

3. Remove low and reverse roller clutch retaining ring. See Figure 75-210.

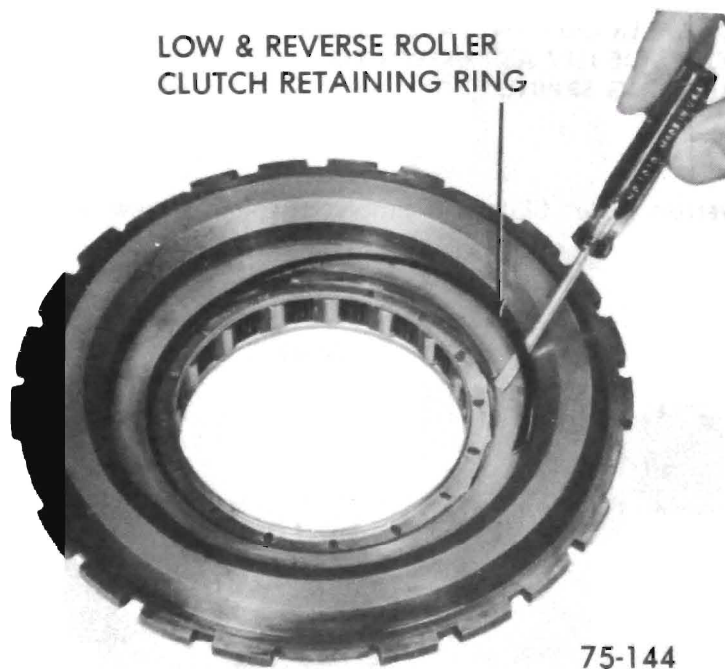

Figure 75-210

4. Remove low and reverse roller clutch assembly and visually inspect the rollers for wearing and scoring and check for any springs that may be collapsed. See Figure 75-211.

#### B. Reassembly of Low and Reverse Roller Clutch Assembly

1. Install low and reverse roller clutch assembly to inner race. See Figure 75-215. The inner race should free wheel in the clockwise direction only.

2. Install low and reverse overrun roller clutch assembly and inner race into the low and reverse clutch support. See Figure 75-216. Assemble with four (4) holes down or to rear of transmission.

3. Install low and reverse clutch to cam retaining ring. See Figure 75-210.

4. Install low and reverse clutch to sun gear drive shell thrust washer. See Figure 75-208.



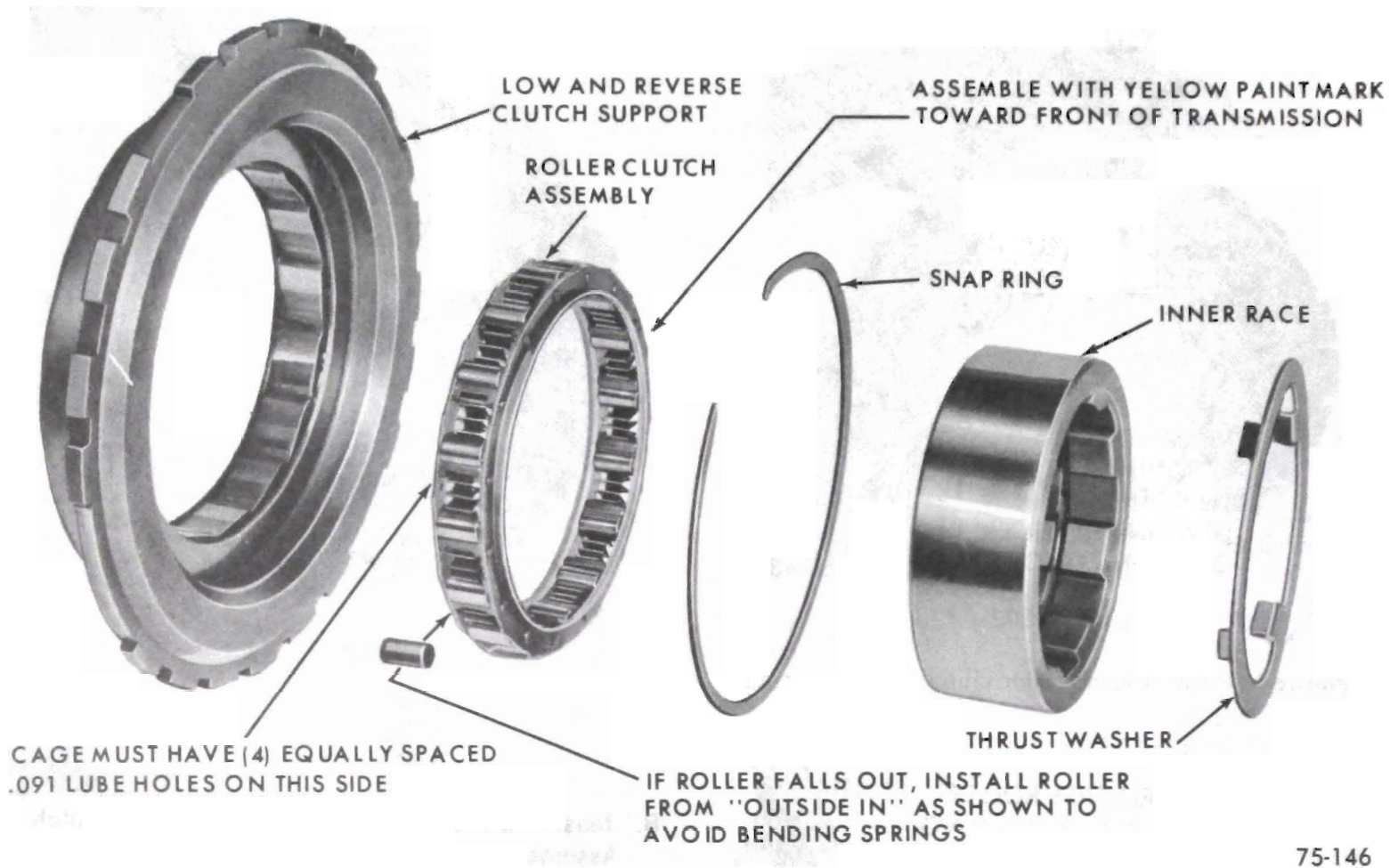

Figure 75-214 - Low and Reverse Clutch Support and Overrun Roller Clutch Assembly - Exploded View

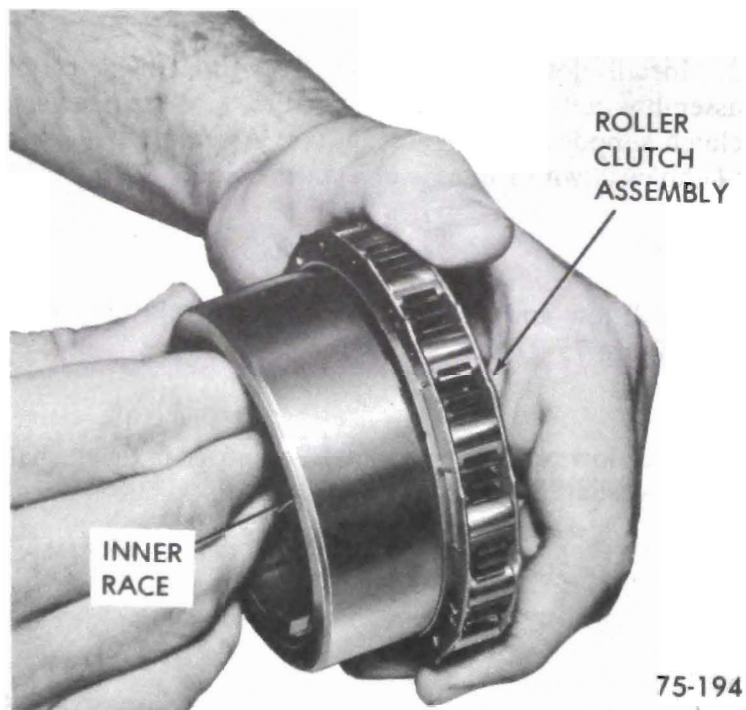

Figure 75-215

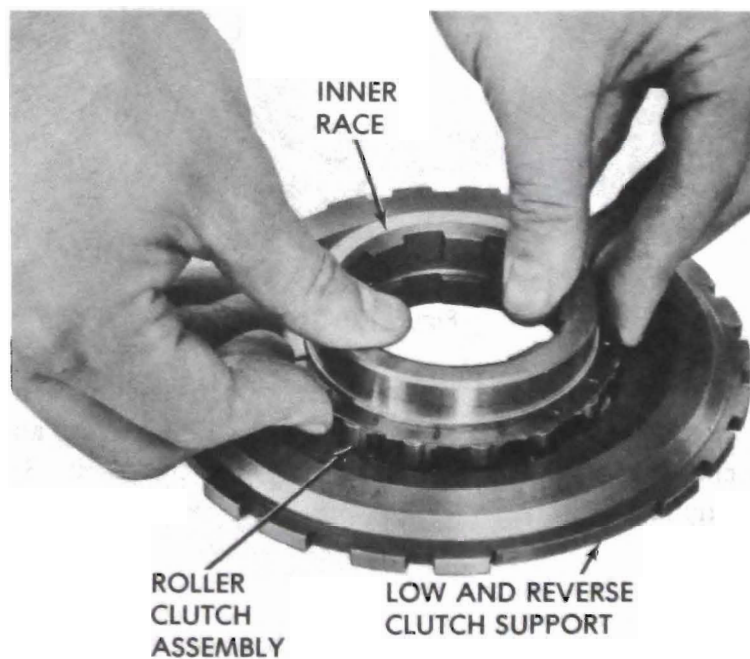

Figure 75-216



## 75-32 VALVE BODY DISASSEMBLY, INSPECTION AND REASSEMBLY

### A. Disassembly of Valve Body (Refer to Figure 75-220)

Transmission need not be removed from car to perform the following operations.

1. Position valve body assembly with cored face up and direct clutch accumulator piston pocket positioned as shown in Figure 75-299.

2. Remove manual valve from lower left hand bore (J).

3. From lower right hand bore (A) remove the pressure regulator valve train retaining pin, boost valve sleeve, intermediate boost valve, reverse and modulator boost valve, pressure regulator valve spring, and the pressure regulator valve.

4. From the next bore (B), remove the 2-3 shift valve train retaining pin, sleeve, control valve spring, 2-3 shift control valve, shift valve spring, and the 2-3 shift valve.

5. From the next bore (C), remove the 1-2 shift valve train retaining pin, sleeve, shift control valve spring, 1-2 shift control valve, and the 1-2 shift valve.

6. From the next bore (E), remove retaining pin, plug, manual low control valve spring, and the manual low control valve.

7. From the next bore (F), remove the retaining pin, spring, seat, and the detent regulator valve.

8. Install Tool J-22269, on direct clutch accumulator piston and remove retaining "E" ring. (G) See Figure 75-220.

9. Remove direct clutch accumulator piston, and metal oil seal ring, and spring. (G)

10. From the next bore down (D) from the direct clutch accumulator, remove the detent actuating lever bracket bolt, bracket, actuating lever and retaining pin, stop, spring retainer, seat, outer spring, inner spring, washer and the detent valve. Use care when handling valve body assembly as valve body sleeve retaining pins may fall out.

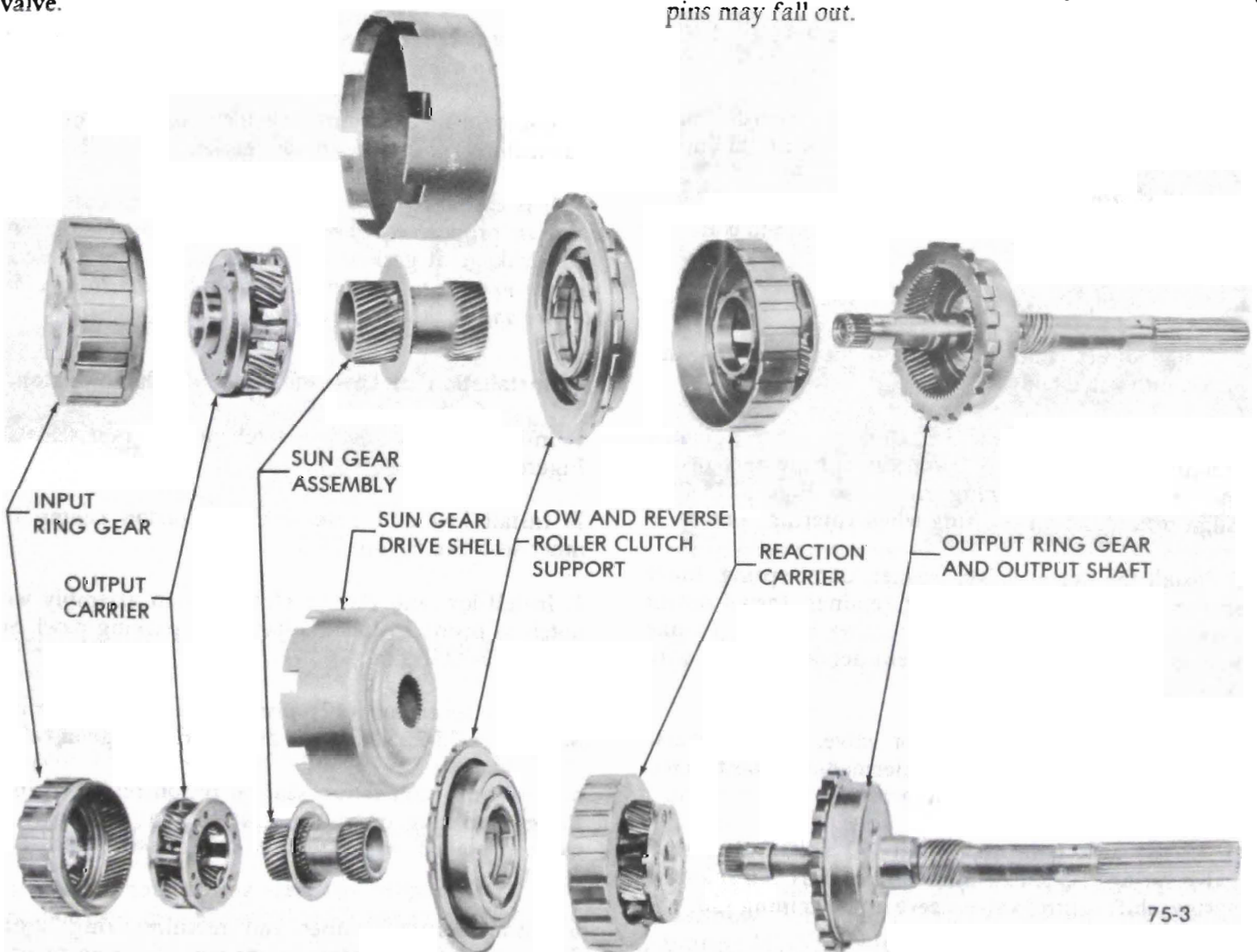
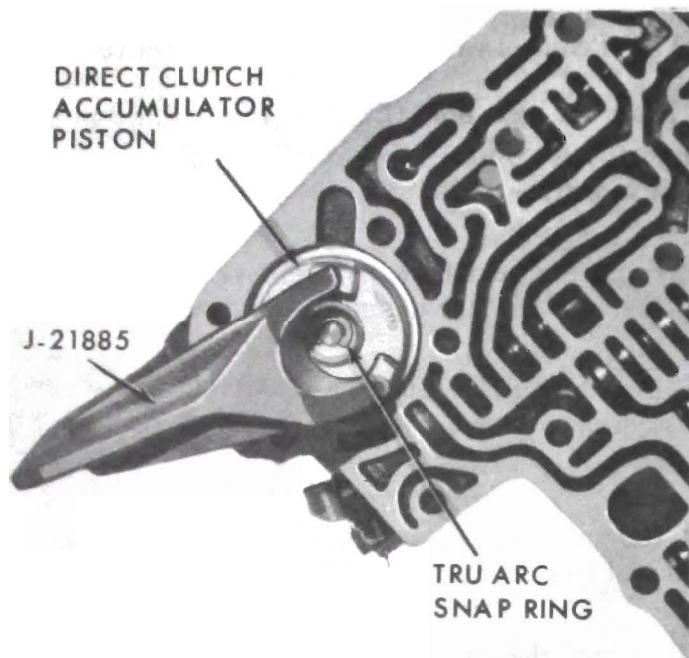

Figure 75-219 - Planetary Gear Train - Exploded View



75-196

Figure 75-220

### B. Valve Body Inspection

1. Inspect all valves for scoring, cracks and free movement in their respective bores.
2. Inspect valve body for cracks, scored bores, interconnected oil passages and flatness of mounting face.
3. Check all springs for distortion or collapsed coils.

### C. Reassembly of Valve Body

1. Install direct clutch accumulator piston spring and piston into valve body.
2. Install special tool J-22269 on direct clutch accumulator piston and compress spring and piston and secure with retaining ring. See Figure 75-220. Align piston and oil seal ring when entering bore.
3. Install the detent valve, washer, outer spring, inner spring, spring seat, and spring retainer. Install detent valve stop and detent valve actuating bracket. Torque bolt to 52 lb. in. Assemble detent actuating lever with retaining pin.
4. Install the pressure regulator valve, spring, reverse and modulator boost valve, intermediate boost valve, boost valve sleeve and retaining pin.
5. In the next bore up, install 2-3 shift valve, shift valve spring, 2-3 shift control valve, shift control valve spring, shift control valve sleeve and retaining pin.
6. In the next bore up, install the 1-2 shift valve, 1-2

shift control valve, control valve spring, control valve sleeve and retaining pin.

7. In the next bore up, install the manual low control valve, spring, plug and retaining pin.

8. In the top right hand bore, install the detent regulator valve, spring seat, spring and retaining pin.

## 75-33 ASSEMBLY OF TRANSMISSION FROM MAJOR PARTS AND UNITS

### A. General Instructions

1. Before starting to assemble the transmission make certain that all parts are *absolutely clean*. Keep hands and tools clean to avoid getting dirt into assembly. If work is stopped before assembly is completed cover all openings with clean cloths.
2. When reassembling it is important that all thrust washer surfaces be given an initial lubrication. Bushings should be lubricated with transmission fluid. Thrust washers should be lubricated on both surfaces with petroleum jelly, (unmedicated) before installation.
3. *Do not take a chance on used gaskets and seals - use new ones to avoid oil leaks.*
4. Use care to avoid making nicks or burrs on parts, particularly on surfaces where gaskets are used.
5. It is extremely important to tighten all parts evenly and in proper sequence, to avoid distortion of parts and leakage at gaskets and other joints. *Use a reliable torque wrench to tighten all bolts and nuts to specified torque and in the specified sequence.*

### B. Installation of Low and Reverse Clutch Piston

1. Install low and reverse clutch piston outer seal. See Figure 75-222.
2. Install low and reverse clutch piston center and inner seal. See Figure 75-223.
3. Install low and reverse clutch piston assembly with notch in piston installed adjacent to parking pawl. See Figure 75-224.
4. Install seventeen (17) piston return (coil) springs. See Figure 75-225. Return springs are orange in color.
5. Position piston return seat on piston return springs. Place snap ring on return seat so that ring may be easily installed when seat is compressed with Tool J-21420.
6. Install spring retainer and retaining ring. Using Tool J-21420-1 compress return seat so spring retainer



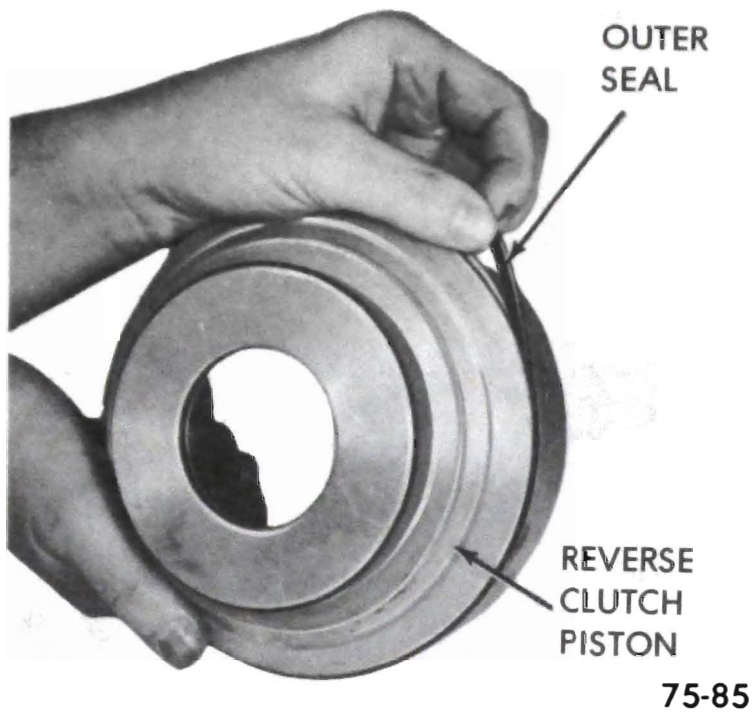

Figure 75-222

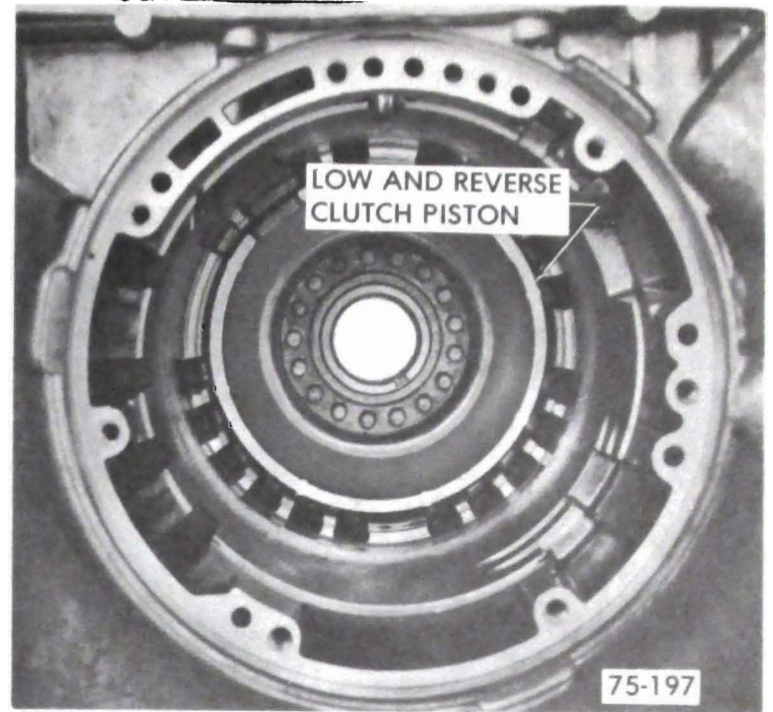

Figure 75-224

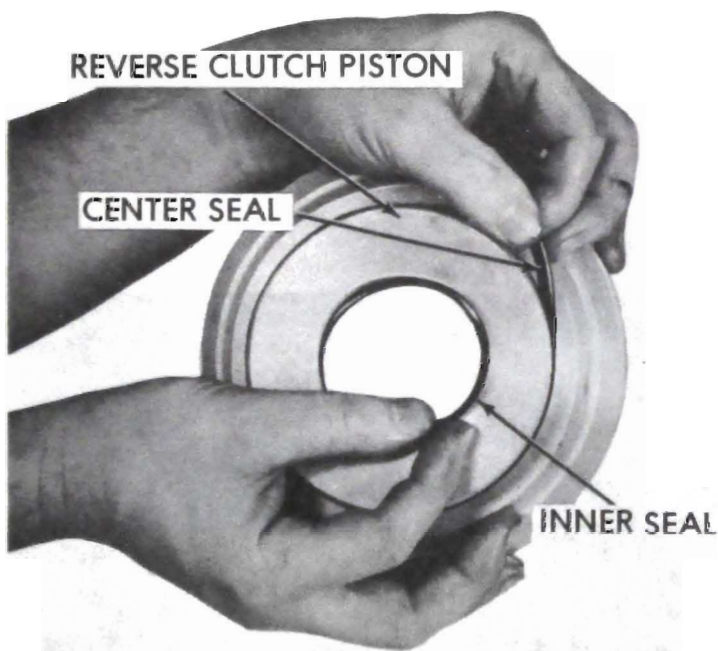

Figure 75-223

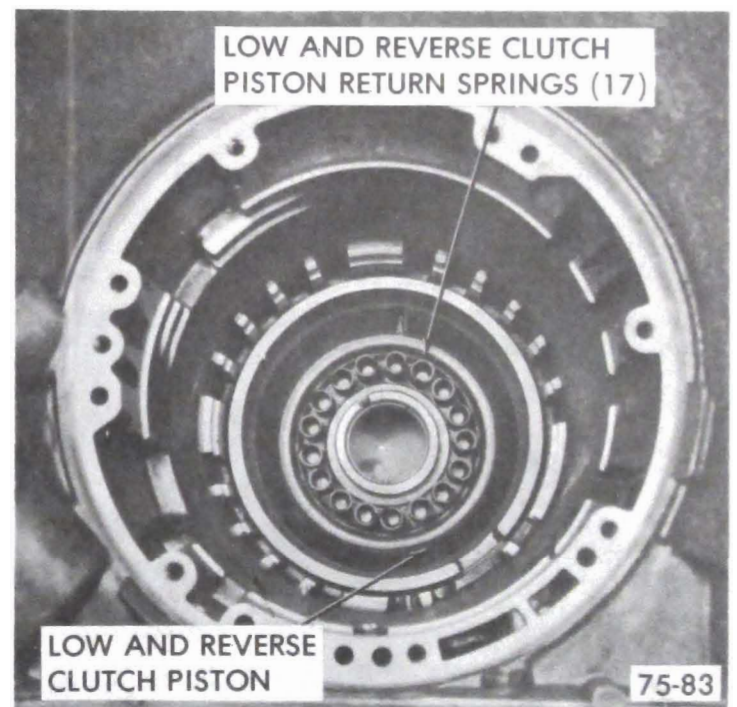

Figure 75-225

retaining ring may be installed with snap ring pliers. See Figure 75-226.

As spring retainer is compressed make certain inner edge of retainer does not hang up on snap ring groove.

### C. Installing Output Shaft and Reaction Carrier

1. Install output ring gear to output shaft. Install output ring gear to output shaft snap ring. See Figure 75-227.

**DO NOT OVER STRESS SNAP RING ON ASSEMBLY. ALWAYS USE NEW RING ON REASSEMBLY.**

2. Install reaction carrier to output ring gear tanged thrust washer. Washer has three (3) tangs see Figure 75-228.

3. Install output ring gear to case needle bearing assembly. See Figure 75-229. Lip on inner race of bearing **MUST** point toward rear of transmission.



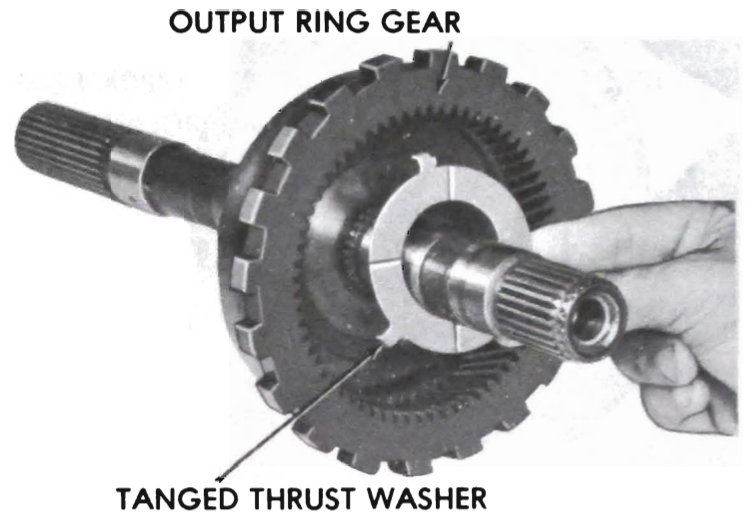
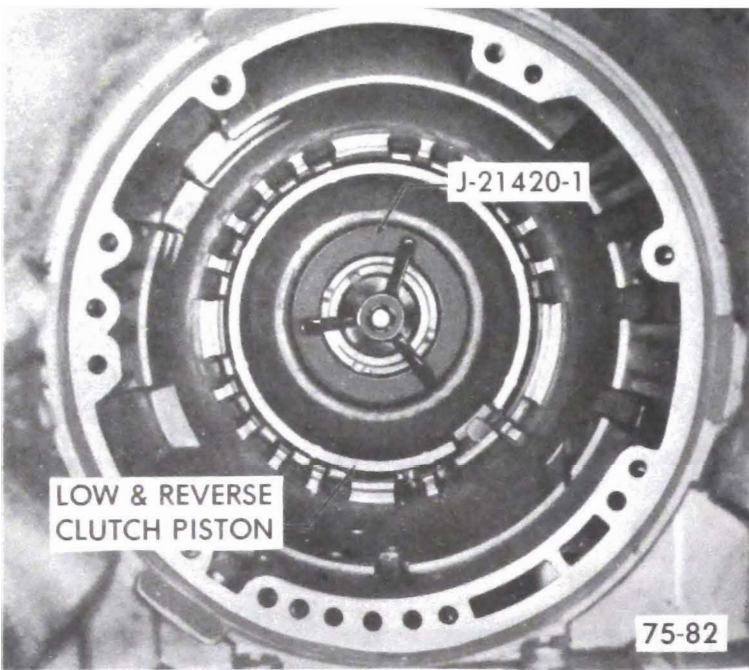

Figure 75-226

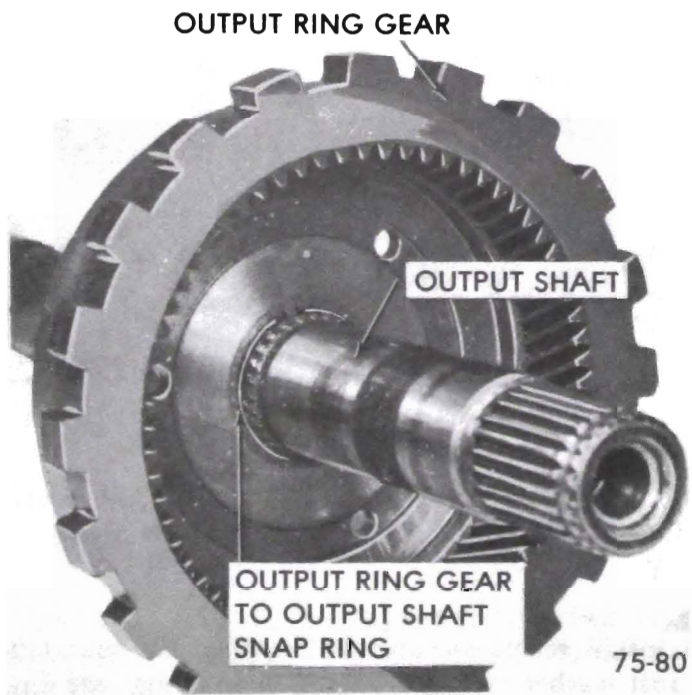

Figure 75-227

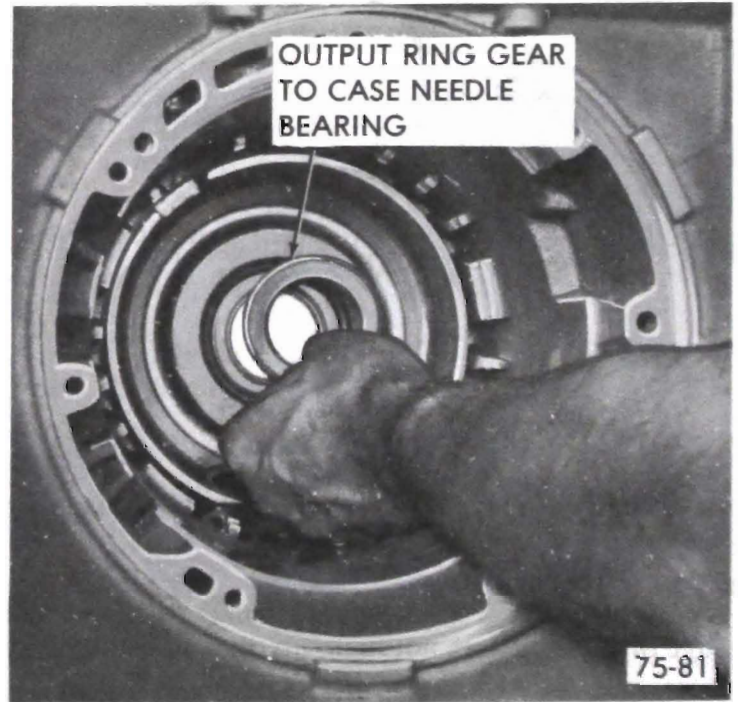

Figure 75-229

4. Install reaction carrier assembly into output ring gear and shaft assembly. See Figure 75- 230.

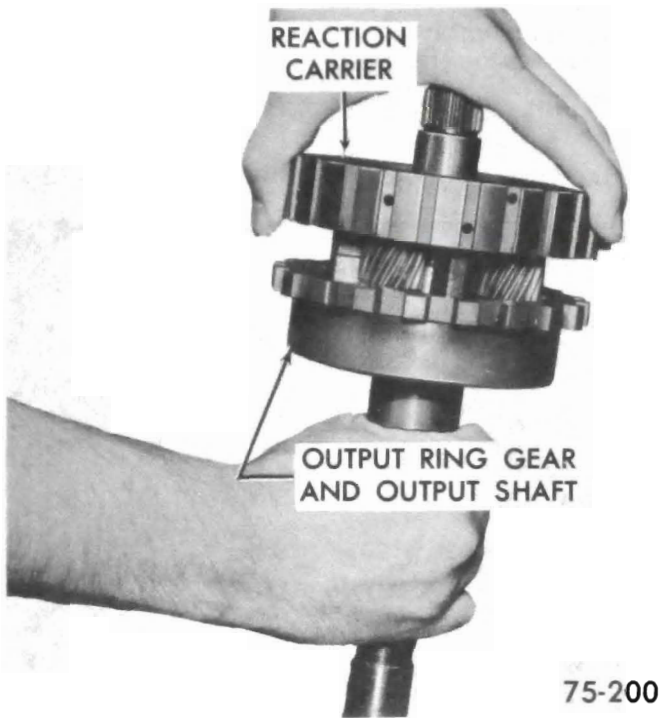

Figure 75-230

#### D. Installing Low and Reverse Clutch Plates

1. Oil and install five (5) low reverse clutch steel separator plates and five (5) faced plates, starting with a steel plate and alternating with faced plates. See Figure 75-232.

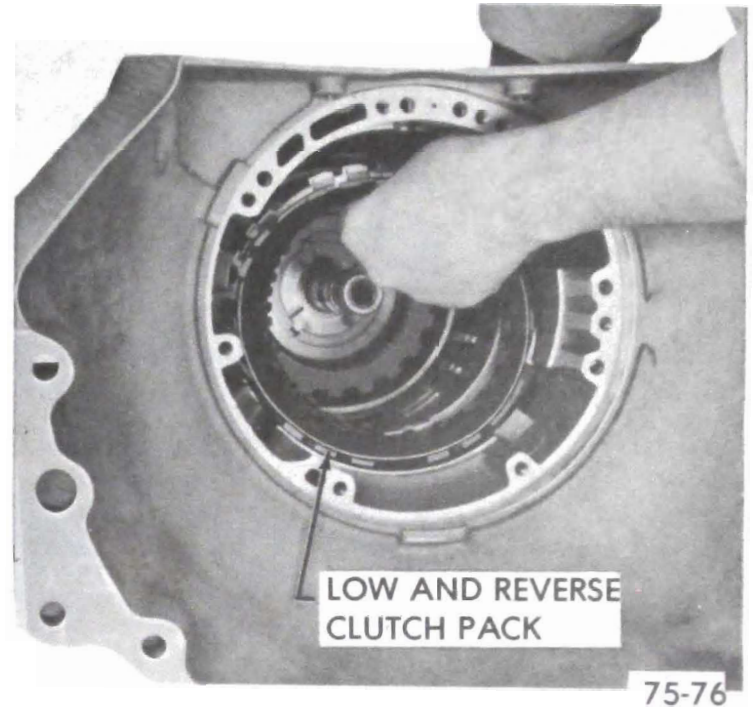

Figure 75-232

5. Install output shaft and reaction carrier assembly into case. See Figure 75-231.

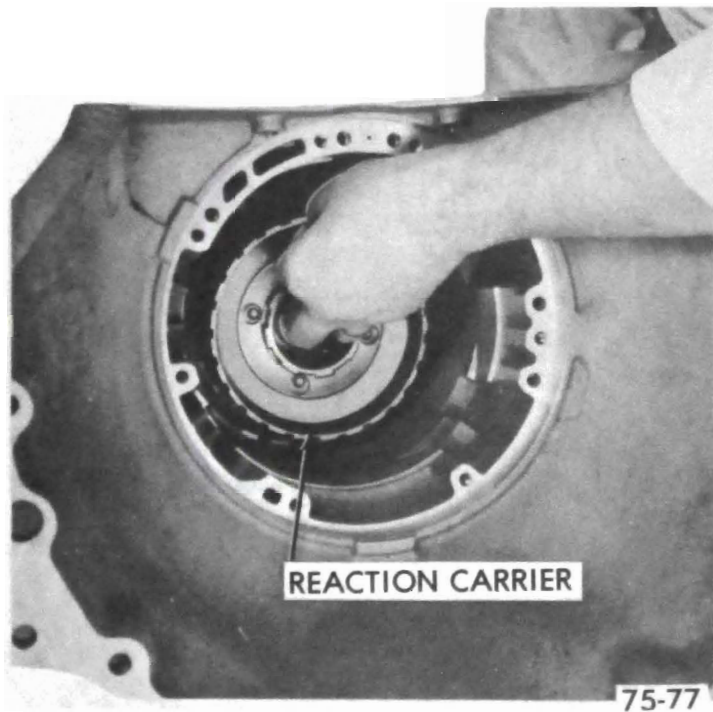

Figure 75-231

2. Install low and reverse clutch support retainer spring. See Figure 75-233.

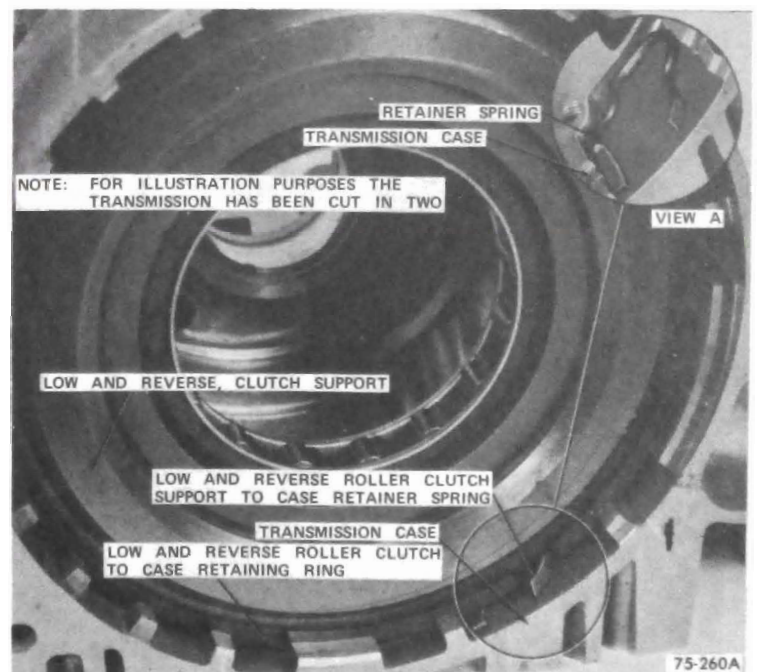

Figure 75-233



3. Install low and reverse clutch support assembly pushing firmly until support assembly is seated past top of low and reverse clutch support retainer spring and retaining ring can be installed. See Figure 75-234.

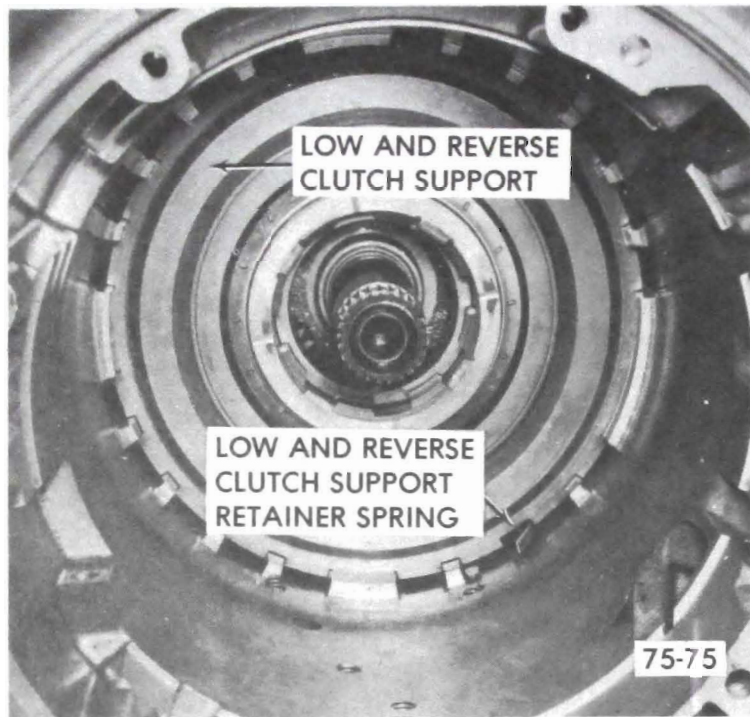

Figure 75-234

Make certain the splines on inner race of the roller clutch align with splines on reaction carrier.

4. Install low and reverse clutch support to case retaining ring. See Figure 75-233.

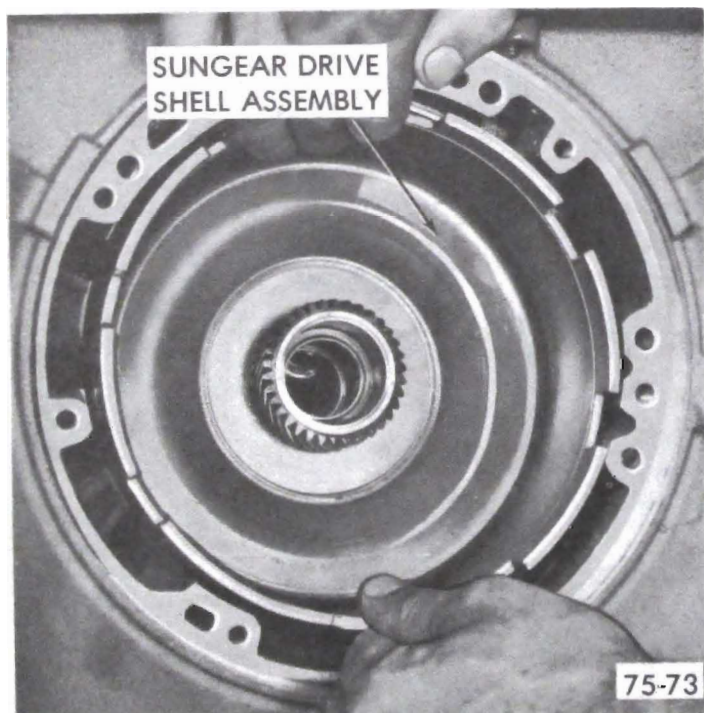

Figure 75-236

### E. Installing Sun Gear Drive Shell Assembly

1. Install low and reverse clutch support inner race to sun gear drive shell thrust washer and install sun gear drive shell assembly.

### F. Installing Output Carrier Assembly

1. Install output carrier assembly. See Figure 75-237.

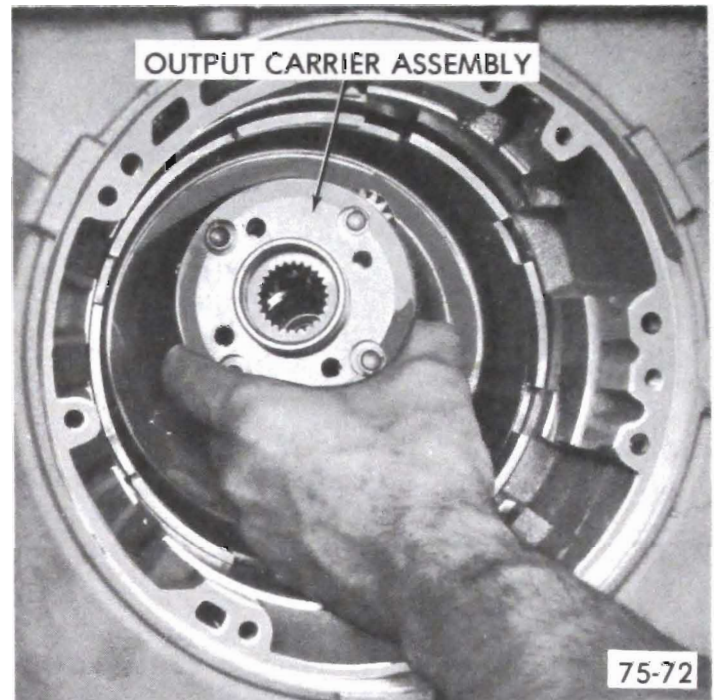

Figure 75-237

2. Install input ring gear to output carrier thrust washer. See Figure 75-238.

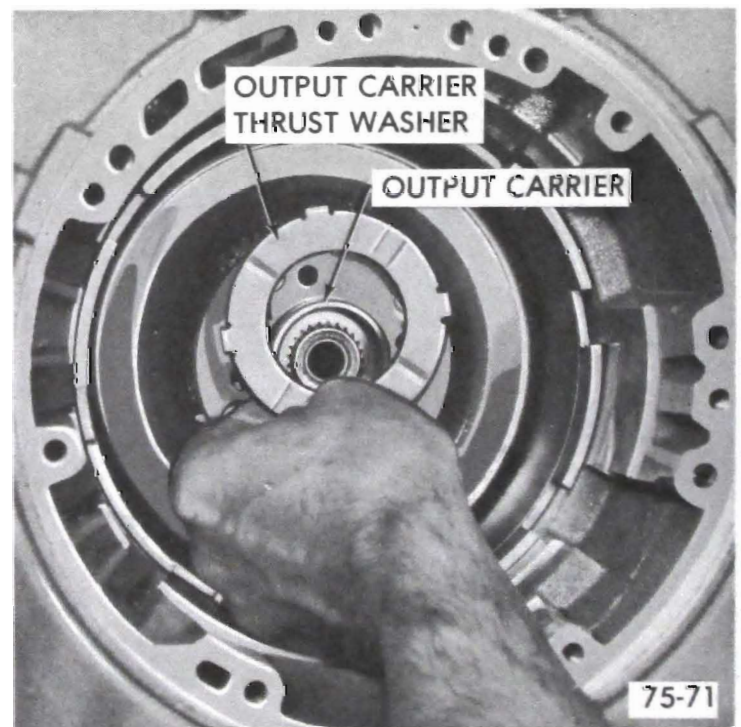

Figure 75-238



### 3. Install output carrier to output shaft snap ring.

Use new snap ring and do not over stress on installing. USE PROPER SNAP RING PLIERS. See Figure 75-239.

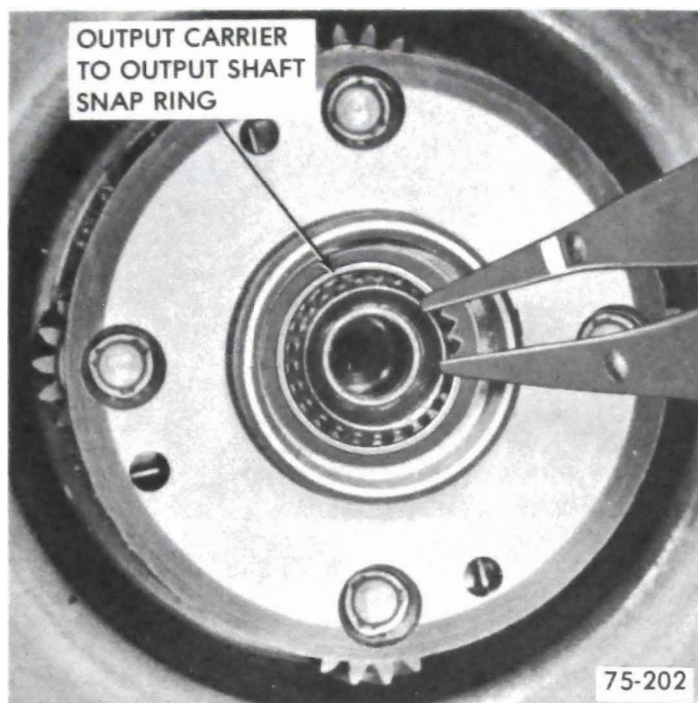

Figure 75-239

### G. Installing Input Ring Gear

1. Install input ring gear. See Figure 75 240.

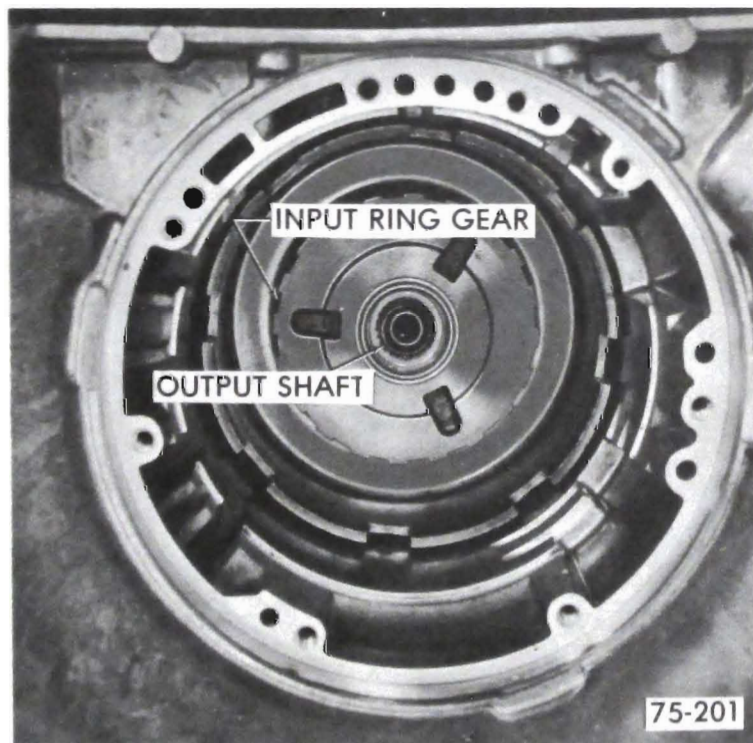

Figure 75-240

2. Install forward clutch housing to input ring gear front thrust washer. See Figure 75-241. Washer has three (3) tangs.

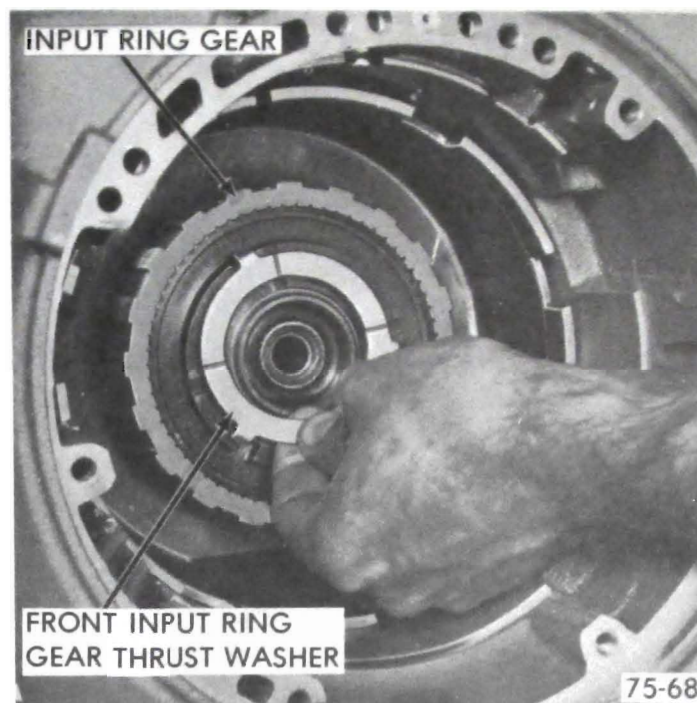

Figure 75-241

### H. Installing Direct and Forward Clutch Assemblies

1. Install direct clutch drum to forward clutch housing needle roller bearing. See Figure 75-242.

#### DIRECT CLUTCH DRUM TO FORWARD CLUTCH HOUSING NEEDLE ROLLER BEARING

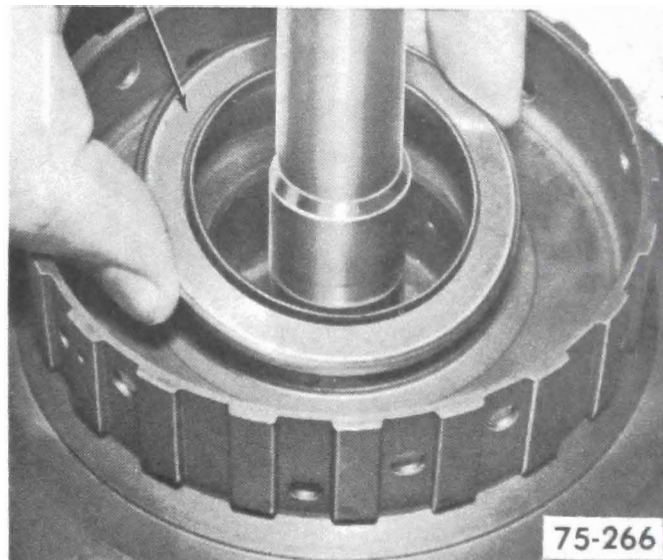

Figure 75-242

2. Install direct clutch assembly to forward clutch assembly. Install assemblies into case making certain forward clutch faced plates are positioned over input ring gear and the tangs on direct clutch housing are installed into slots on the sun gear drive shell. See Figure 75-243.



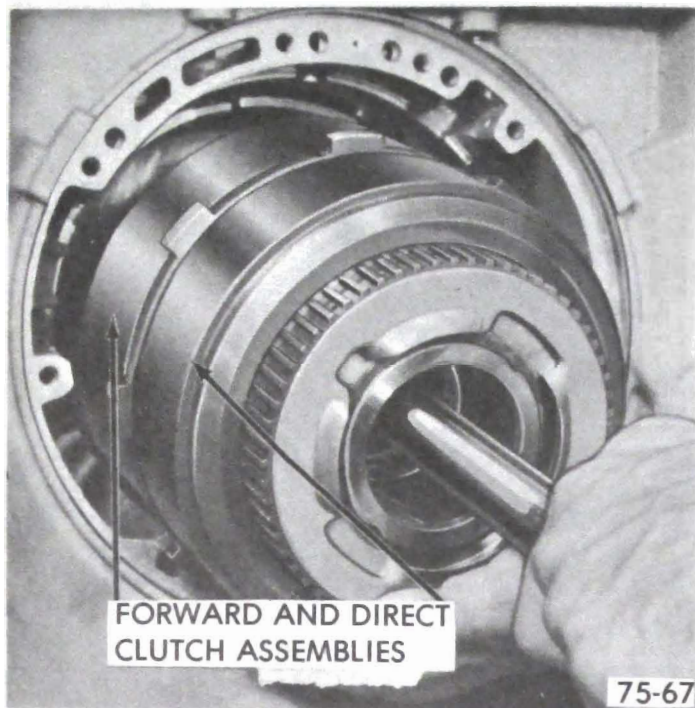

Figure 75-243

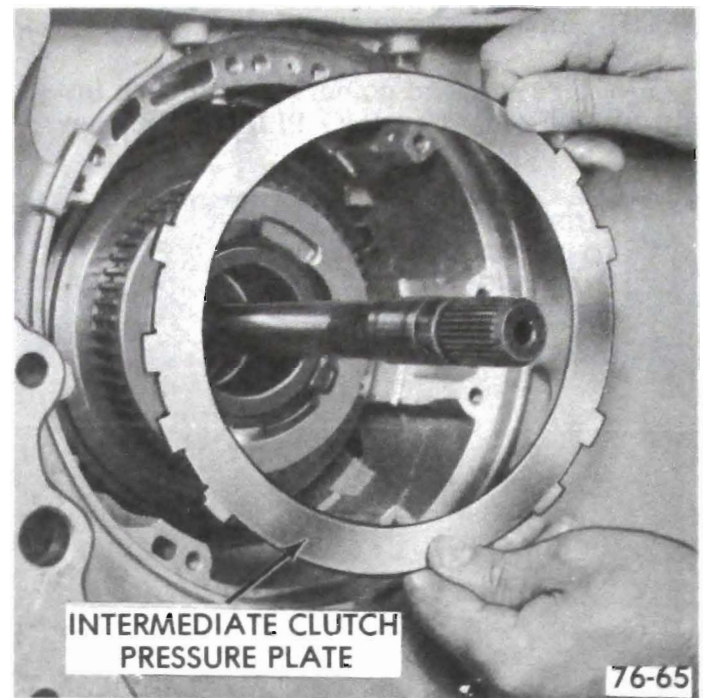

Figure 75-245

### I. Installing Intermediate Clutch Overrun Brake Band

1. Install intermediate clutch overrun brake band. See Figure 75-244.

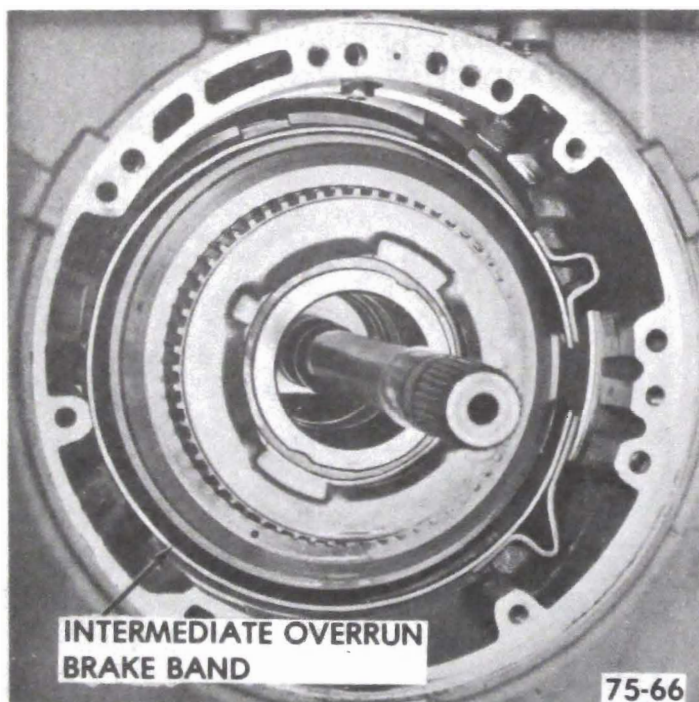

Figure 75-244

2. Oil and install three (3) faced and three (3) steel intermediate clutch plates, starting with a faced plate and alternating steel and faced. See Figure 75-246.

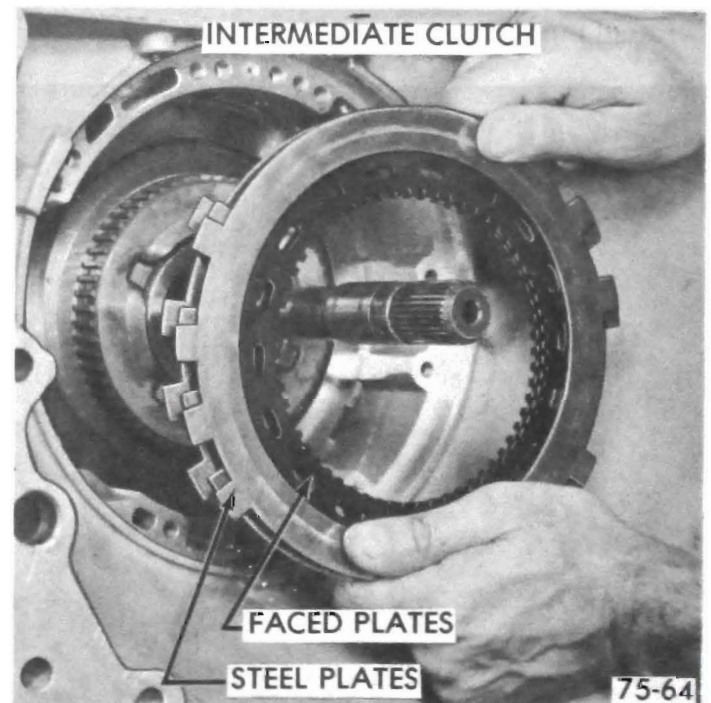

Figure 75-246

### J. Installing Intermediate Clutch Pressure Plate, Clutch Plates, and Cushion Spring

1. Install intermediate clutch pressure plate. See Figure 75-245.

3. Install intermediate clutch cushion spring. See Figure 75-247.



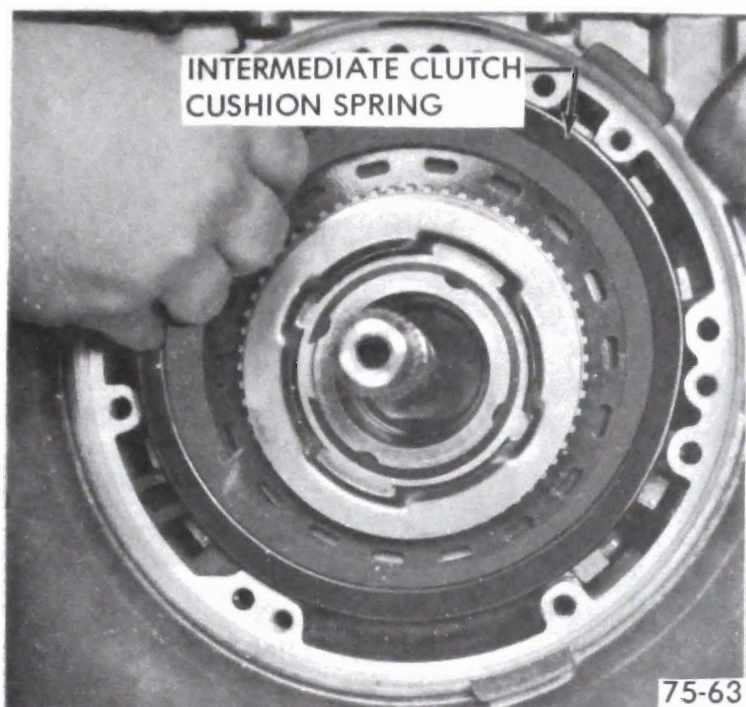

Figure 75-247

#### K. Check Direct Clutch to Oil Pump Clearance

1. Install guide pins into case. See Figure 75-251.
2. Install pump into case. Remove guide pins and install pump to case bolts.
3. Attach slide hammer bolt to threaded hole in oil pump. See Figure 75-248. With flat of hand on end of input shaft move shaft rearward. Install Dial Indicator Set J-8001 on rod and "O" dial indicator on end of input shaft. Push on end of output shaft to move shaft forward, the reading obtained will be the clearance. There are three selective thrust washers available, .065"-.067", .082"-.084", and .099"-.101" thick.

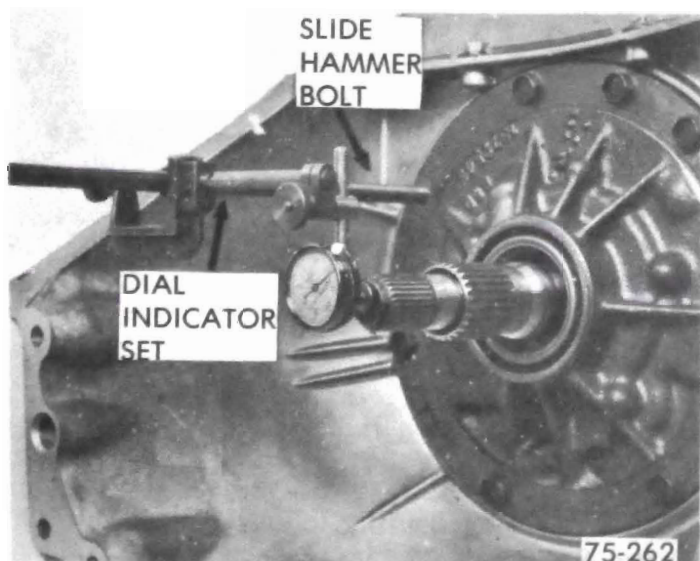

Figure 75-248

Select washer so the clearance will be between .033" and .064".

4. Remove pump assembly. Install selective fit washer to pump cover hub. Before installation apply petroleum jelly to both sides of washer.

#### L. Installing Oil Pump Assembly

1. Install new pump assembly to case gasket. See Figure 75-249.

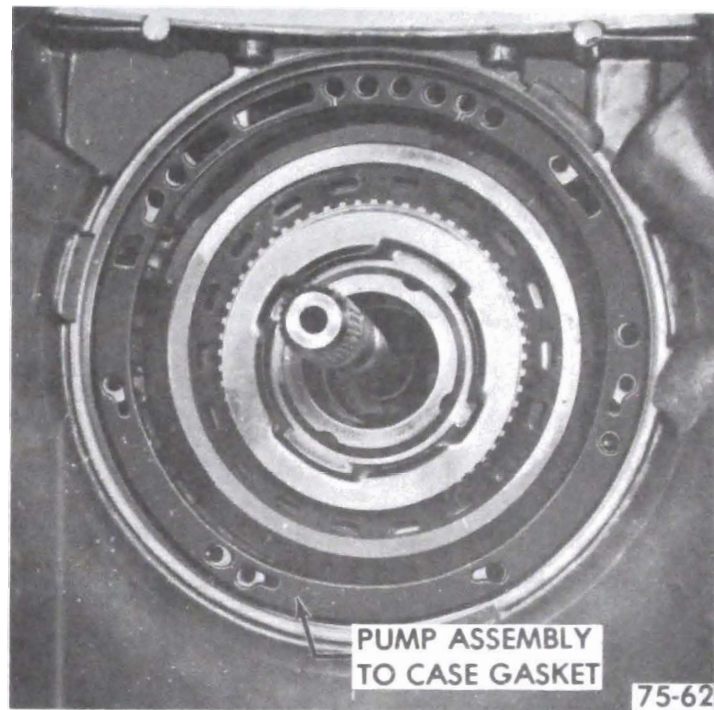

Figure 75-249

2. Install guide pins into case. See Figure 75-250. Before installing, pump lubricate case bore.

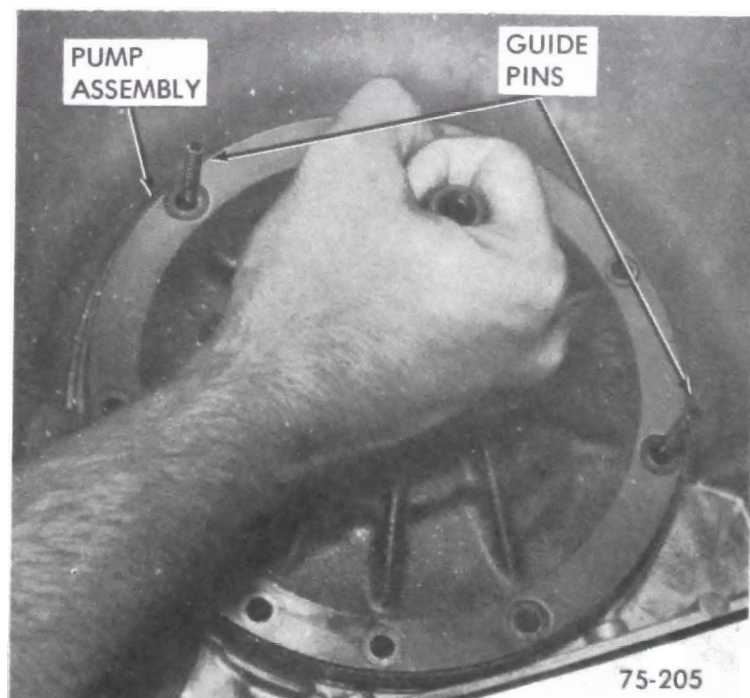

Figure 75-250



3. Install pump assembly into case. Install attaching bolts with new washer type seals. Torque to 20 lb.ft. See Figure 75-251.

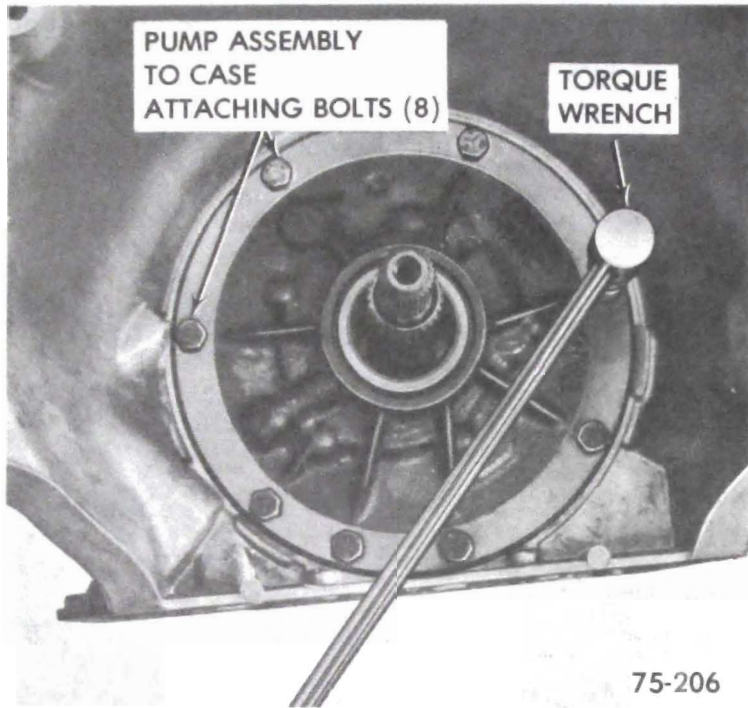

Figure 75-251

If input shaft cannot be rotated as the pump is being pulled into place, the direct and forward clutch housings have not been properly installed to index the faced plates with their respective parts. This condition must be corrected before the pump is pulled into place.

#### M. Installing Speedometer Drive Gear, and Propeller Shaft Yoke Seal

1. Place speedometer drive gear retaining clip into hole in output shaft. See Figure 75-252.

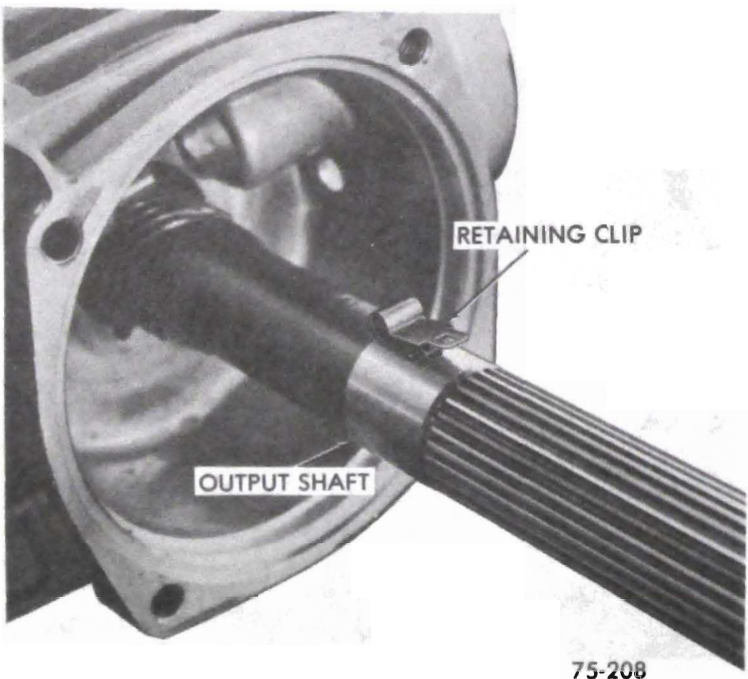

Figure 75-252

2. Align slot in speedometer drive gear with retaining clip and install. See Figure 75-253.

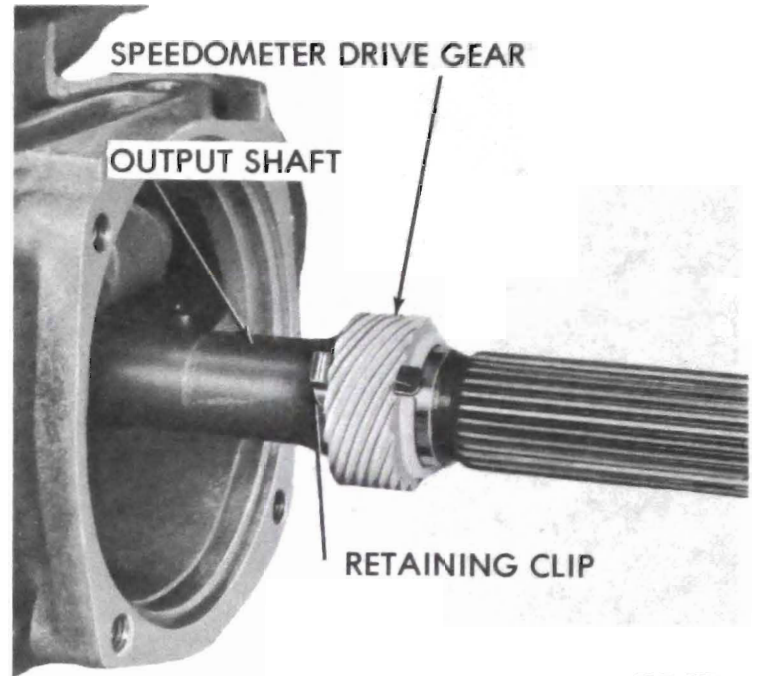

Figure 75-253

3. Install propeller shaft yoke seal (375B only), using Tool J-23103. See Figure 75-254.

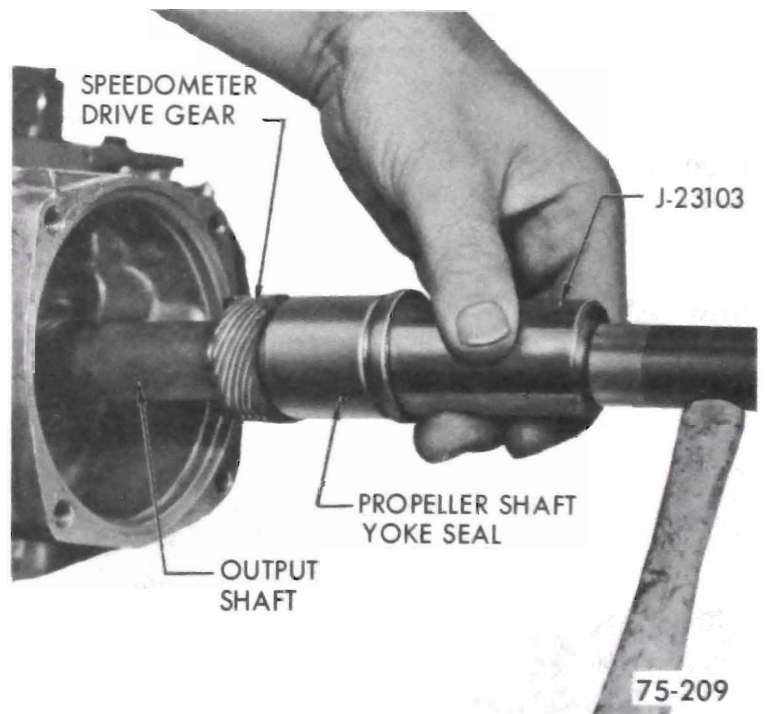
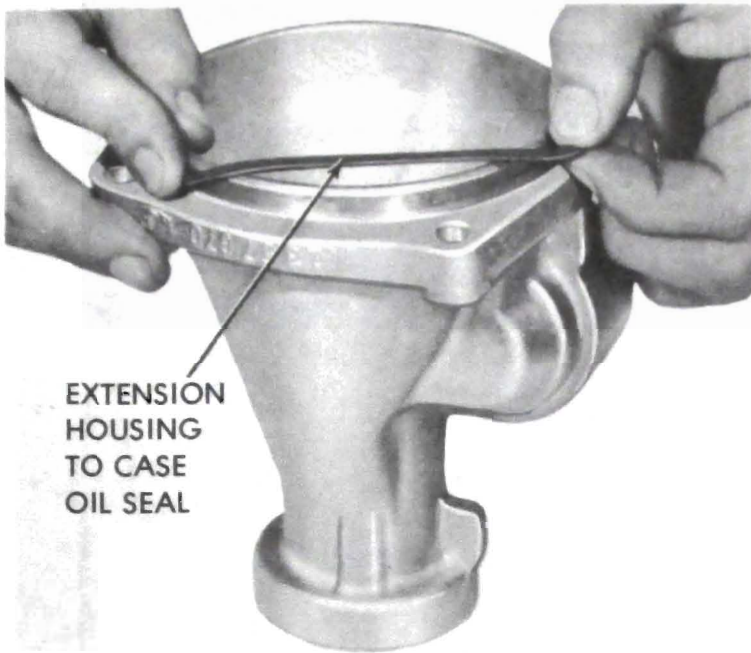

Figure 75-254

#### N. Installing Extension Housing

1. Install extension housing to case square cut "O" - ring seal. See Figure 75-255.



75-32

Figure 75-255

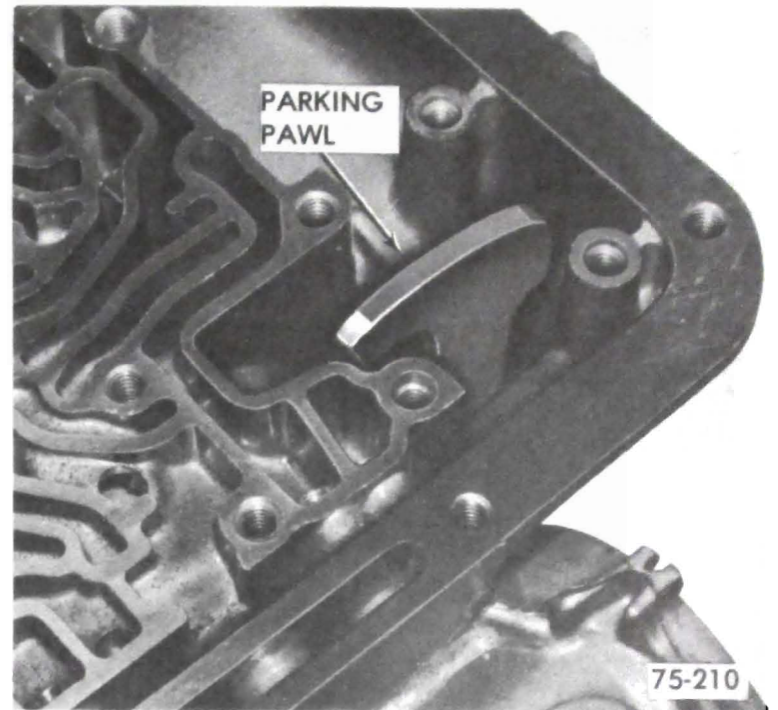

75-210

Figure 75-257

2. Attach extension housing to case using attaching bolts. Torque to 35 lb.ft. See Figure 75-256.

3. Install speedometer driven gear, retainer and bolt. Torque bolt to 12 lb.ft.

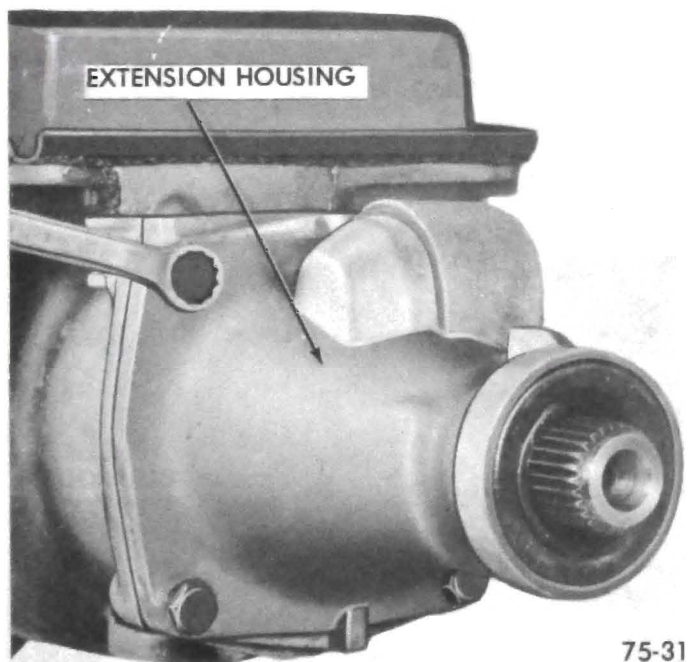

75-31

Figure 75-256

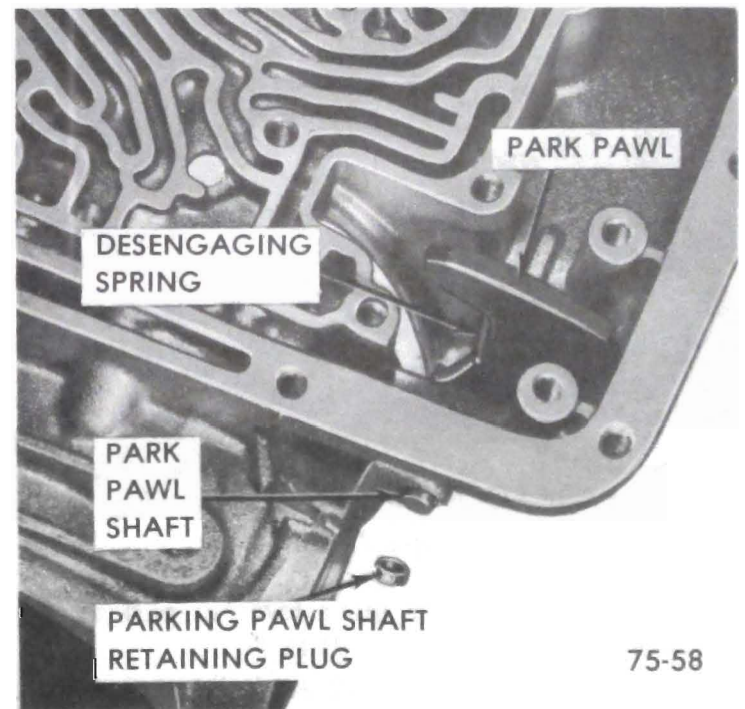

75-58

Figure 75-258

## O. Installing Parking Pawl and Actuating Rod

1. Install parking pawl, tooth toward the inside of case, into case. See Figure 75-257.

2. Install parking pawl shaft into case through disengaging spring. Install disengaging spring on parking pawl and slide shaft through parking pawl.

3. Install parking pawl shaft retainer plug. Drive into case using a 3/8" dia. rod, until retainer plug is flush to .010" below face of case. Stake plug in three (3) places to retain plug in case. See Figure 75-259.

4. Install park lock bracket, torque bolts to 29 lb.ft. See Figure 75-260.



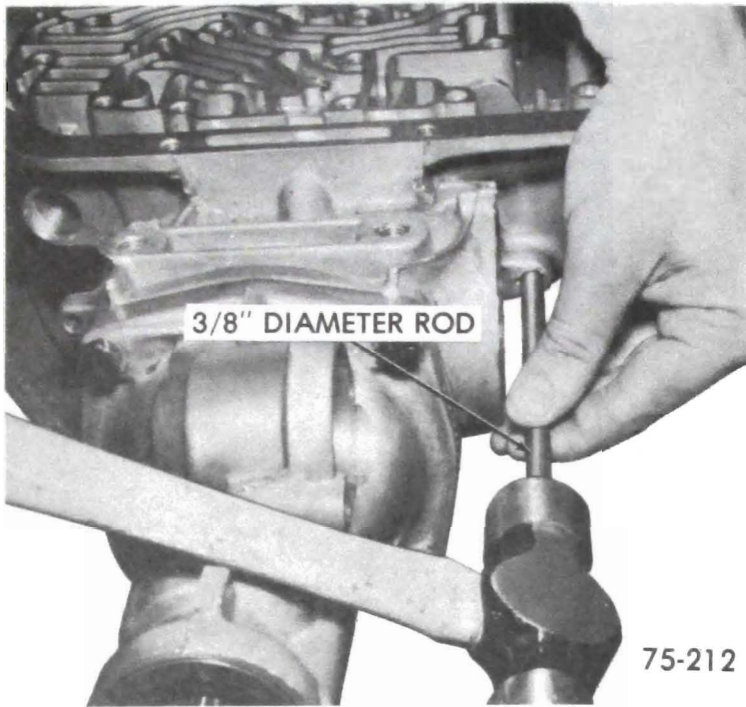

Figure 75-259

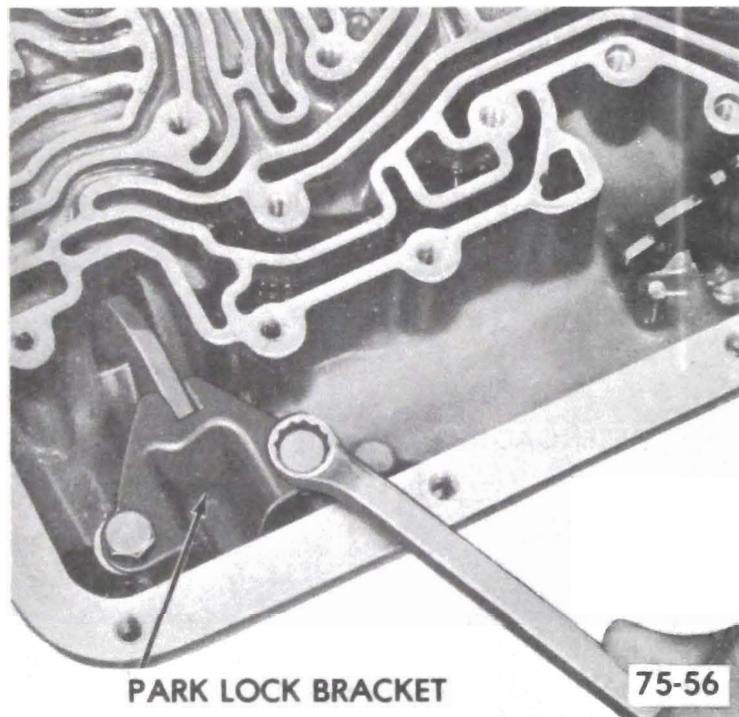

Figure 75-260

5. Install range selector inner lever to parking pawl actuating rod. See Figure 75-261.

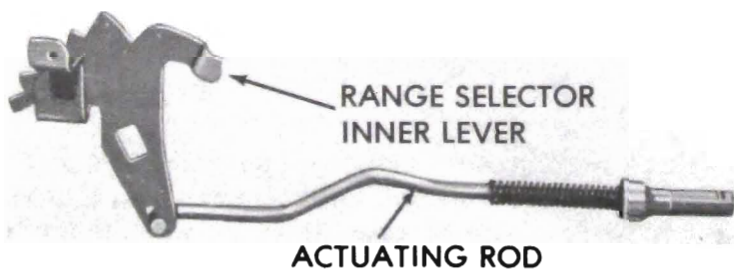

Figure 75-261

6. Install actuating rod under the park lock bracket and parking pawl. See Figure 75-262.

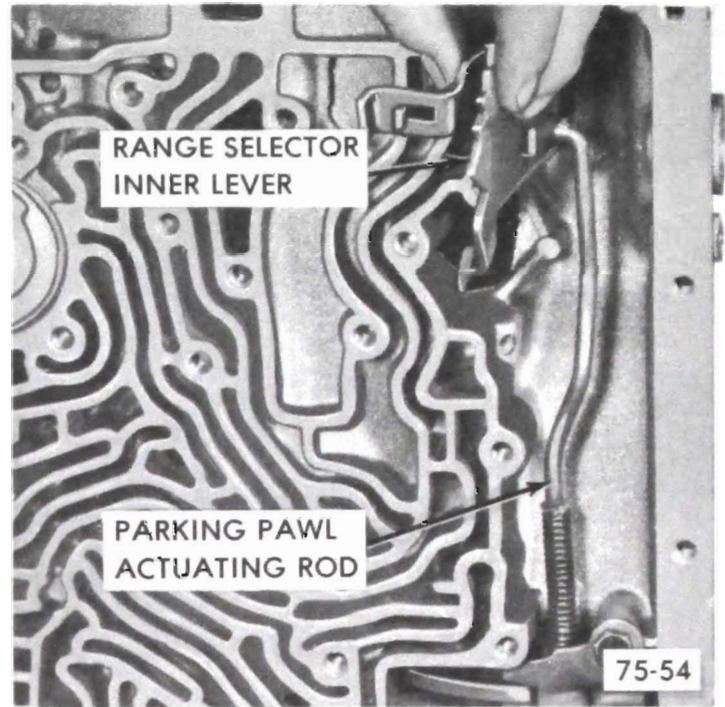

Figure 75-262

**P. Installing Manual Shaft and Range Selector Inner Lever**

1. If a new manual shaft to case lip seal is necessary, use a 7/8 inch diameter rod and seat flush with case. See Figure 75-263.

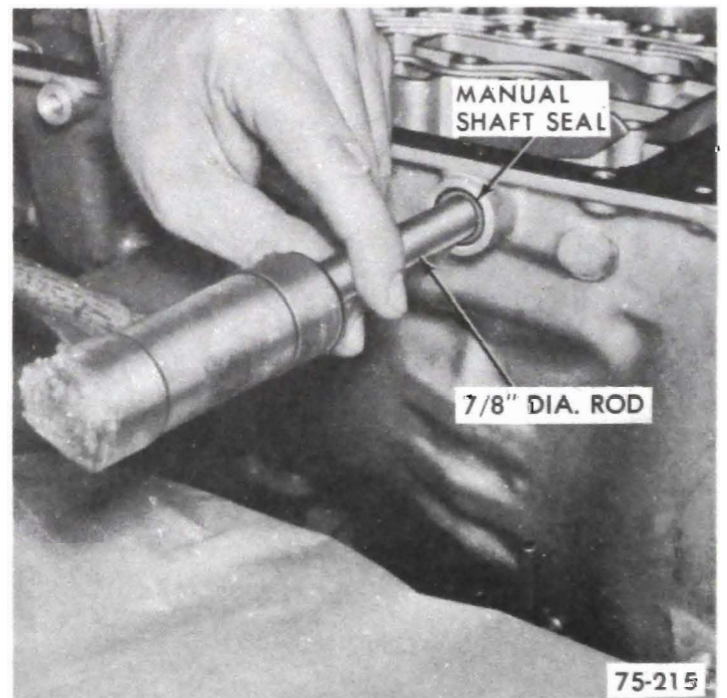

Figure 75-263

2. Install manual shaft through case and range selector inner lever. See Figure 75-264.



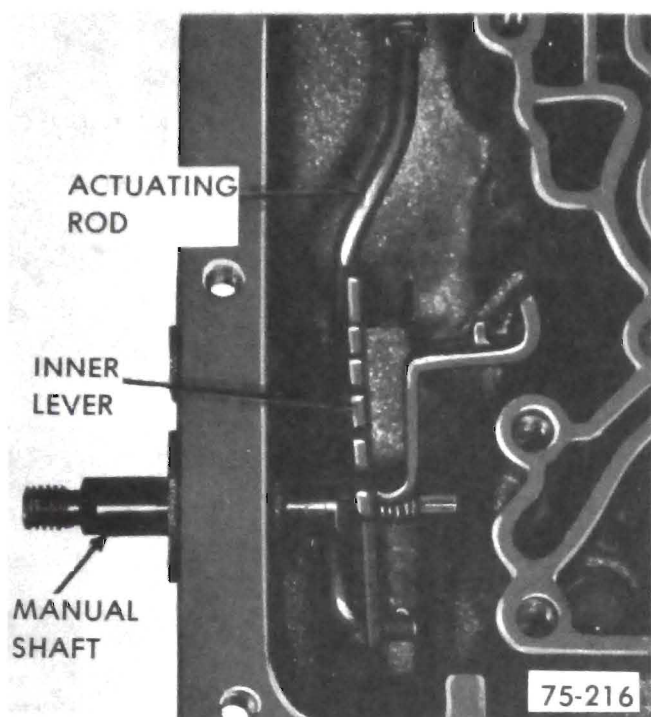

Figure 75-264

3. Install retaining jam nut on manual shaft. Torque jam nut to 30 lb.ft. See Figure 75-265.

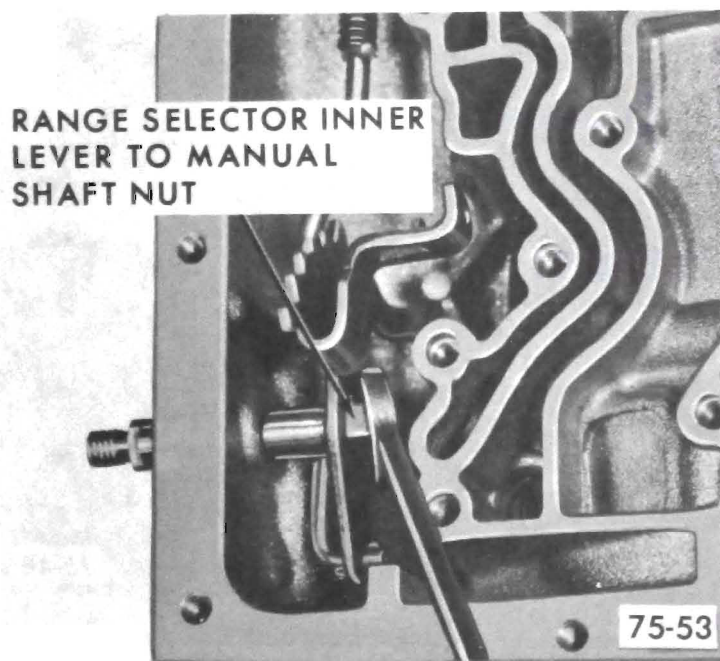

Figure 75-265

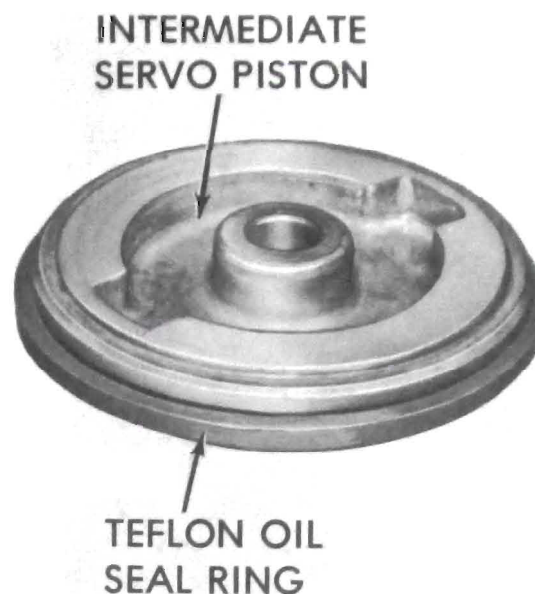

Figure 75-266

75-219

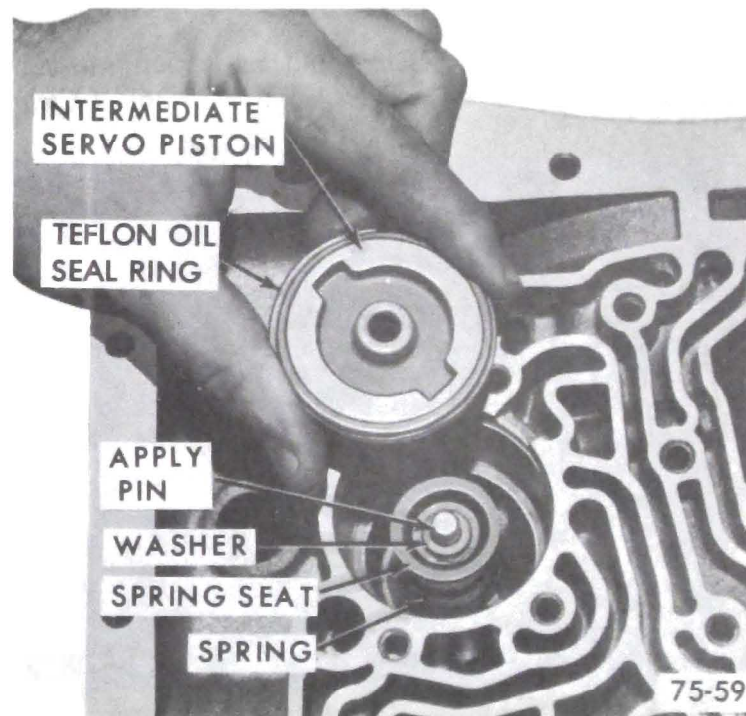

Figure 75-267

#### Q. Installing Intermediate Servo Piston, Check Balls, Oil Pump Pressure Screen and Governor Feed Screens

1. Install oil seal ring on the intermediate servo piston. See Figure 75-266. Oil seal ring must not be cast iron (dark colored).

2. Install intermediate servo piston, apply pin, spring seat. See Figure 75-267.

3. Install four (4) check balls into correct transmission case pockets. See Figure 75-268.

If number one (1) check ball is omitted or incorrectly placed, transmission failure will result due to minimum line pressure.

If transmission is still in car, place check balls in proper position in spacer plate and gasket and carefully raise into position.

4. Install oil pump pressure screen in the oil pump



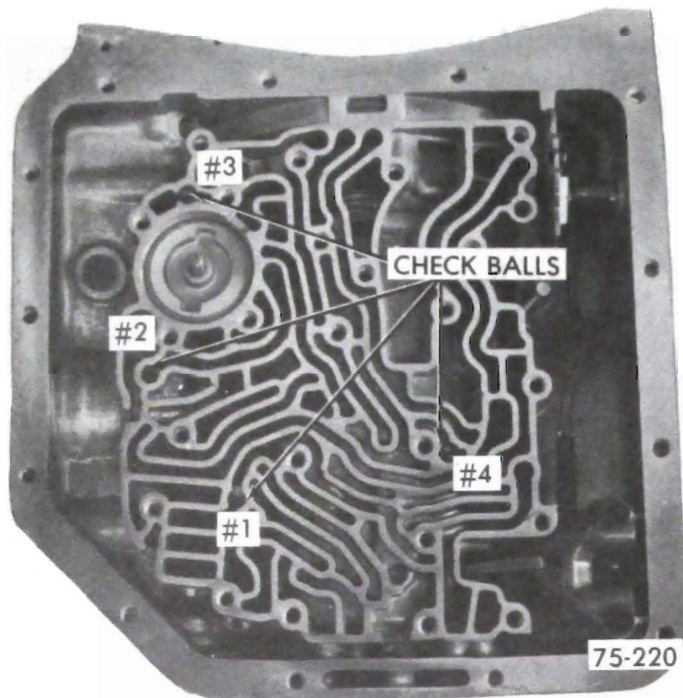

Figure 75-268

pressure hole in case. Ring end of screen must be installed toward case face. See Figure 75-269. (*Clean before installing.*)

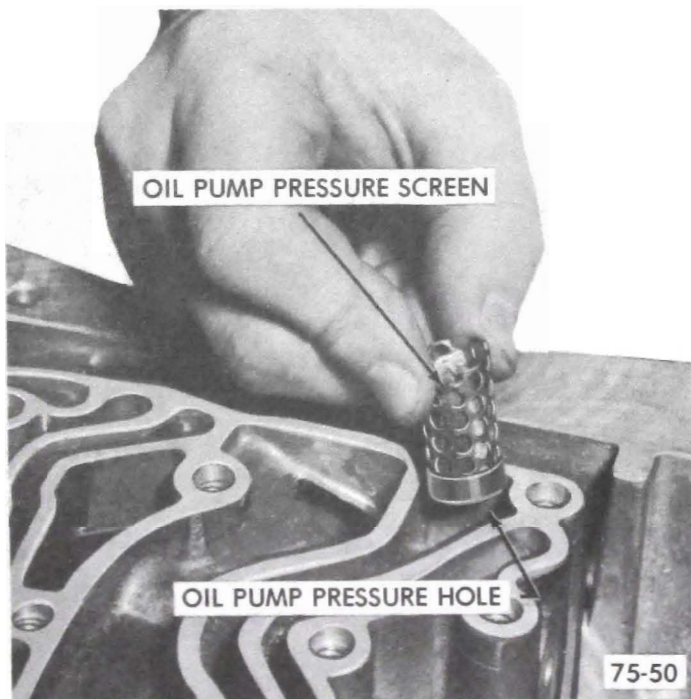

Figure 75-269

5. Install governor screens in the case. See Figure 75-270. (*Clean before installing.*)

#### R. Installing Valve Body, Detent Roller and Spring Assembly, and Strainer

1. Install valve body spacer plate to case gasket and valve body spacer plate. See Figure 75-271.



Figure 75-270

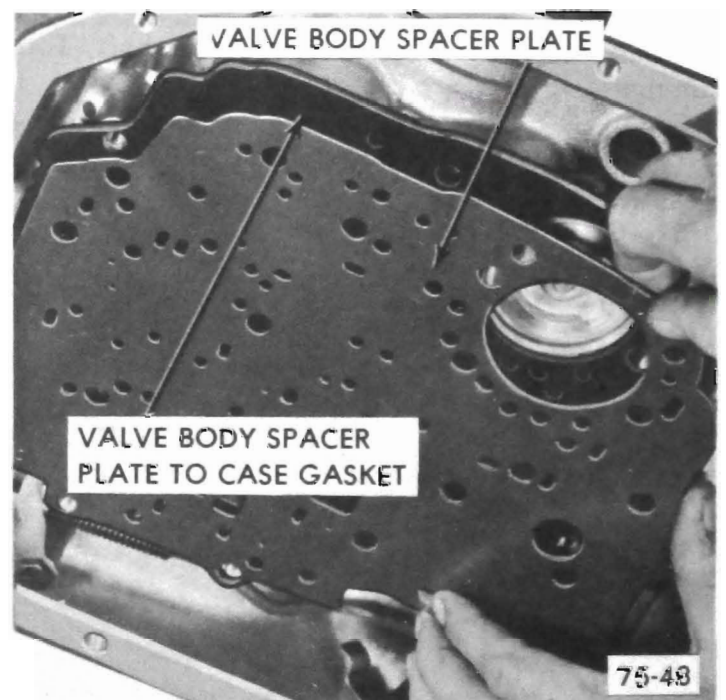

Figure 75-271

2. Install valve body to spacer plate gasket. See Figure 75-272.

Be sure that plate and gasket are 1971 service parts, if replacement is required. Do not use any past model service parts on 1971 transmissions.

3. Install spacer support plate. Torque bolts to 13 lb.ft. See Figure 75-273.



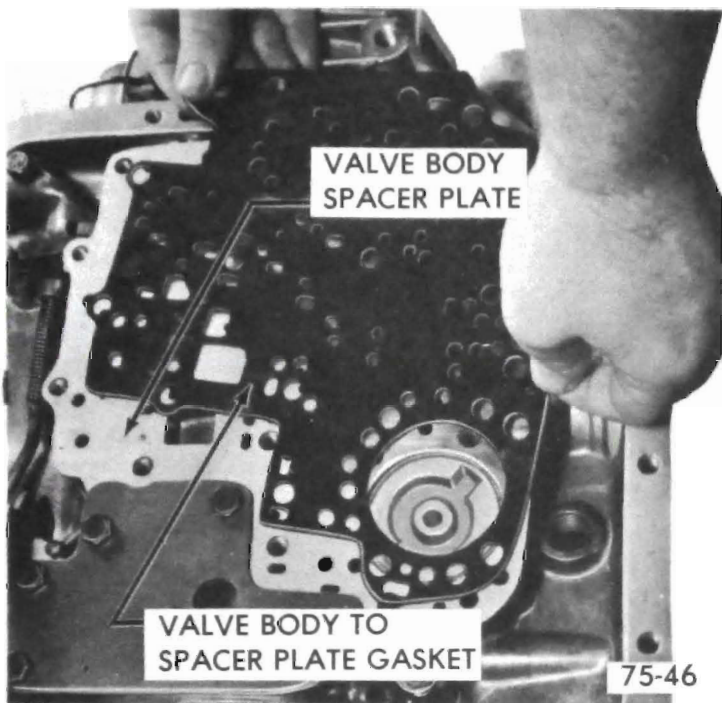

Figure 75-272

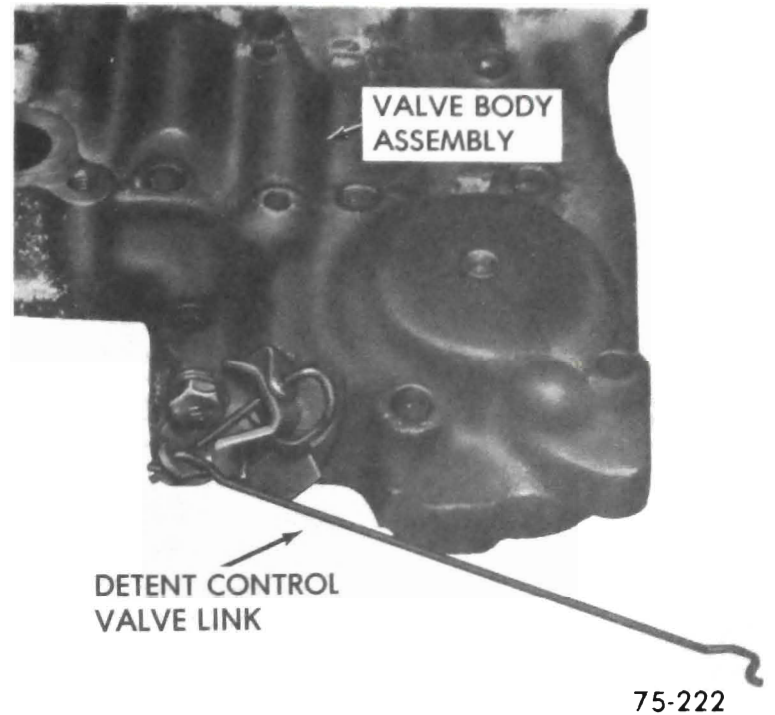

Figure 75-274

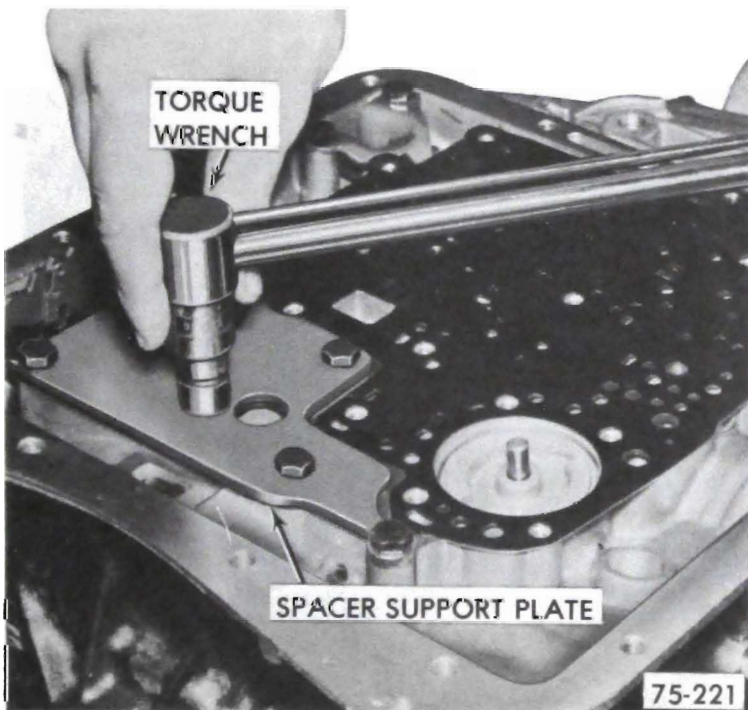

Figure 75-273

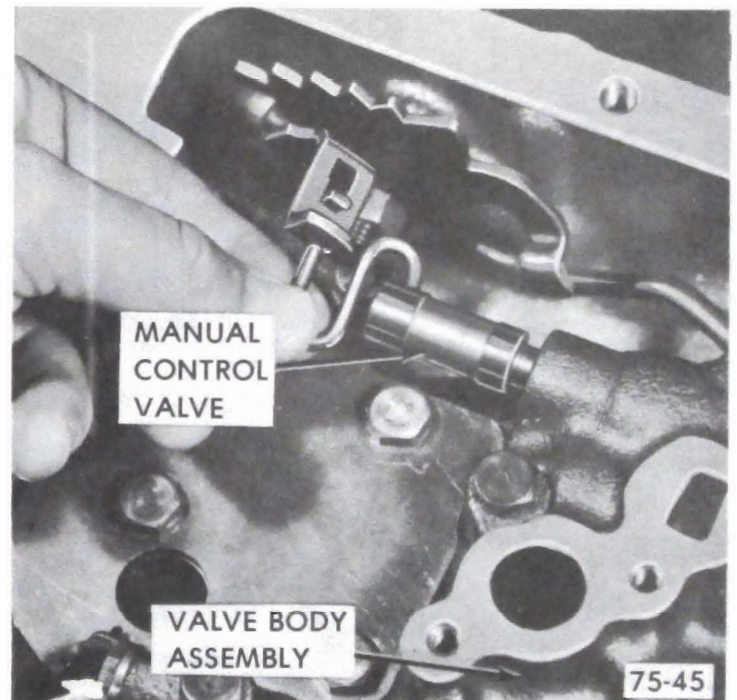

Figure 75-275

4. Connect detent control valve wire to detent valve actuating lever. See Figure 75-274.

5. Install valve body. Connect manual control valve link to range selector inner level. Torque bolts in random sequence to 13 lb.ft. leaving bolt loose for detent roller and spring assembly. See Figure 75-275.

When handling valve body assembly do not touch sleeves as retainer pins will fall into transmission.

6. Install manual shaft to case retainer ring. See Figure 75-276.

7. Install detent roller and spring assembly to valve body. See Figure 75-277.

8. Install strainer assembly gasket and strainer. See Figure 75-278. Install strainer and gasket exactly as shown. Always flush out screens and check for foreign material.



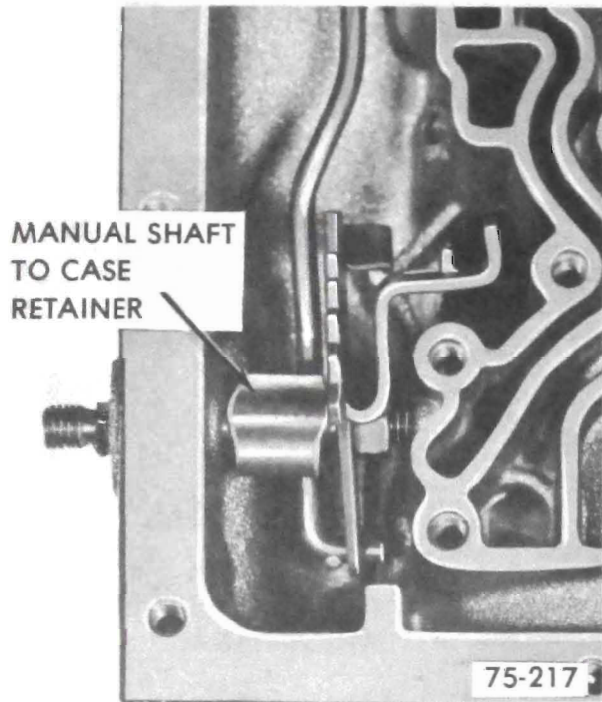

Figure 75-276

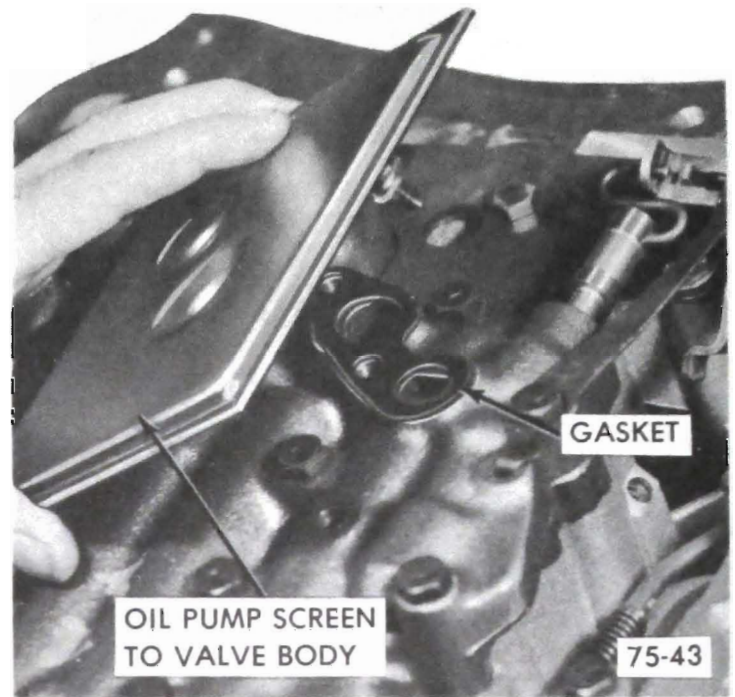

Figure 75-278

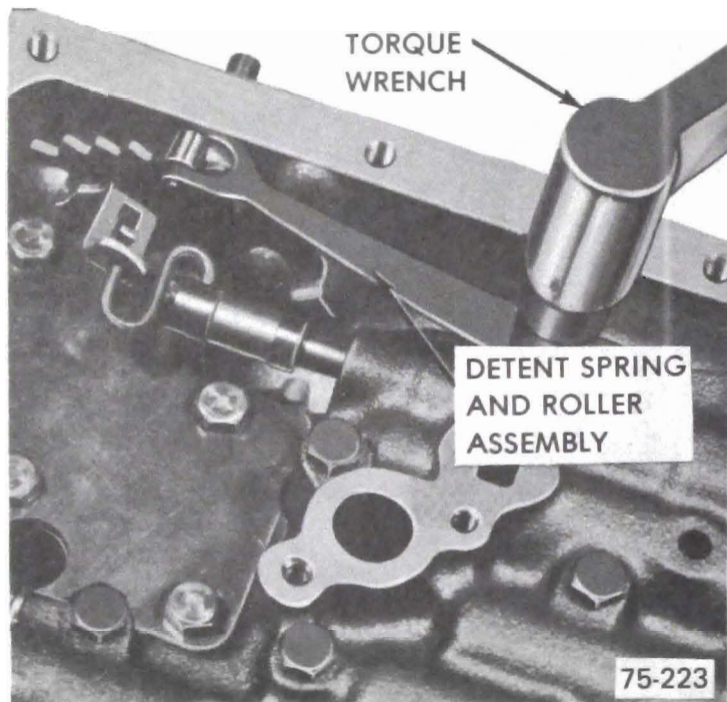

Figure 75-277

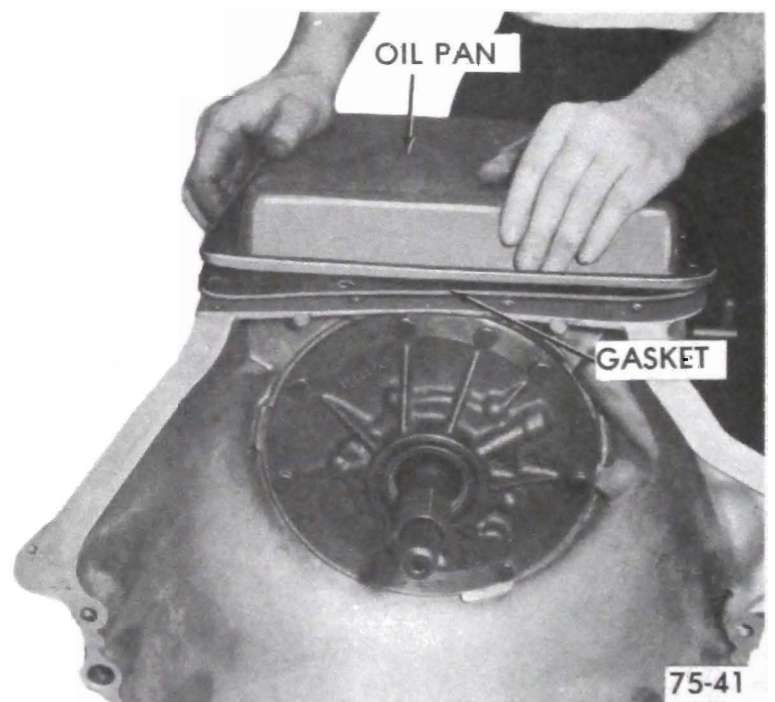

Figure 75-279

### S. Installing Oil Pan, Governor, and Modulator Valve

1. Install new bottom pan gasket and bottom pan. See Figure 75-279.

Intermediate clutch accumulator assembly should be installed before oil pan is installed. Refer to paragraph 75-26 for disassembly and reassembly.

2. Install governor assembly, cover and seal and retainer wire. See Figure 75-280. Use extreme care not

to damage cover. If cover is damaged it must be replaced.

3. Install vacuum modulator valve. See Figure 75-281. Lubricate "O" ring seal to prevent damage.

4. Install vacuum modulator and retainer clip. Torque bolt to 12 lb.ft. See Figure 75-282.

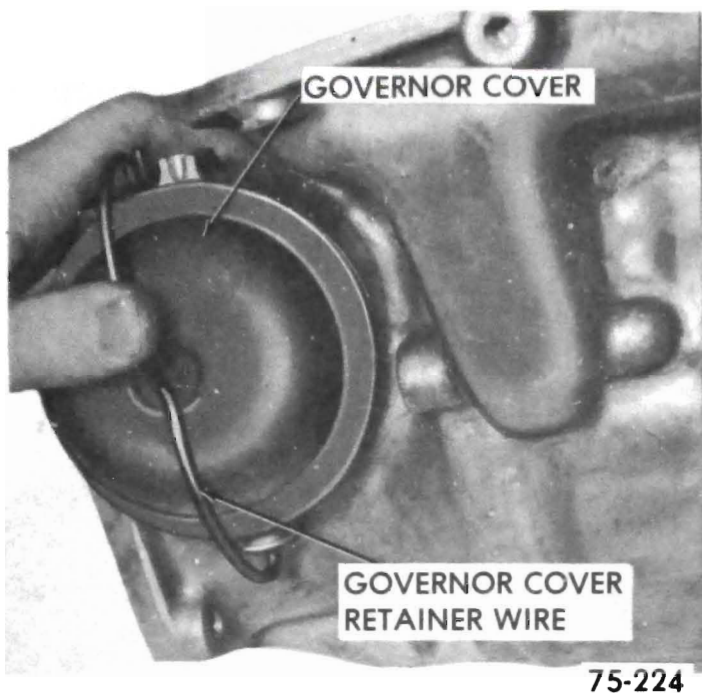

Figure 75-280

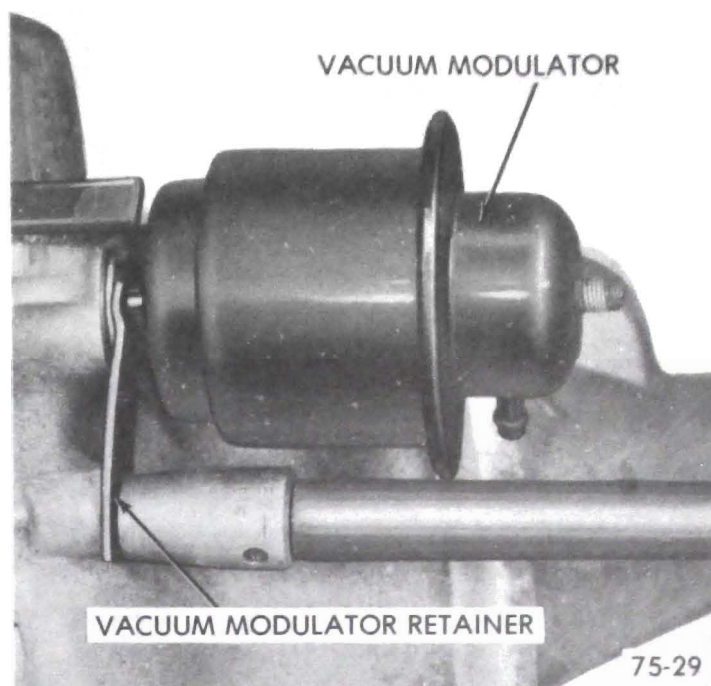

Figure 75-282

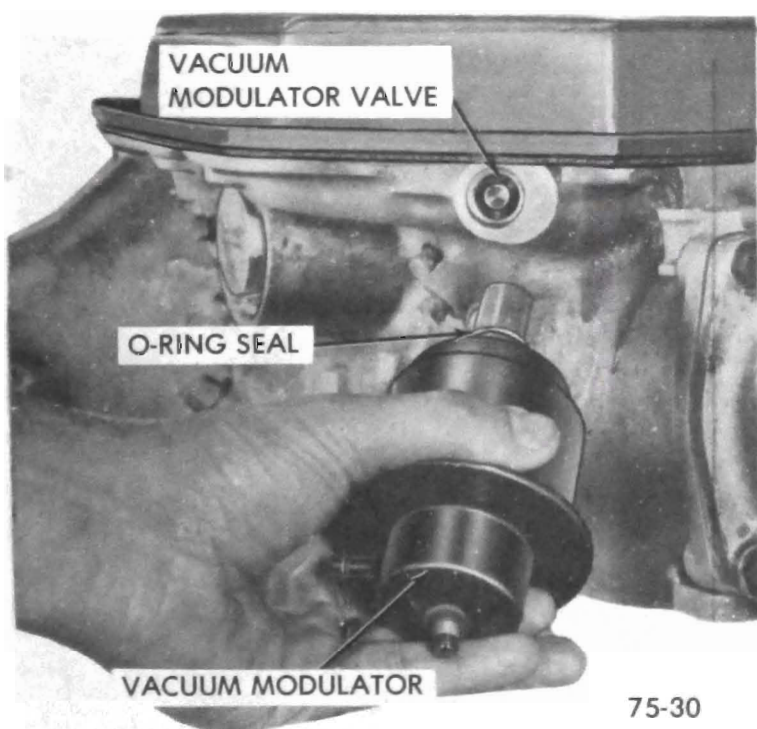

Figure 75-281

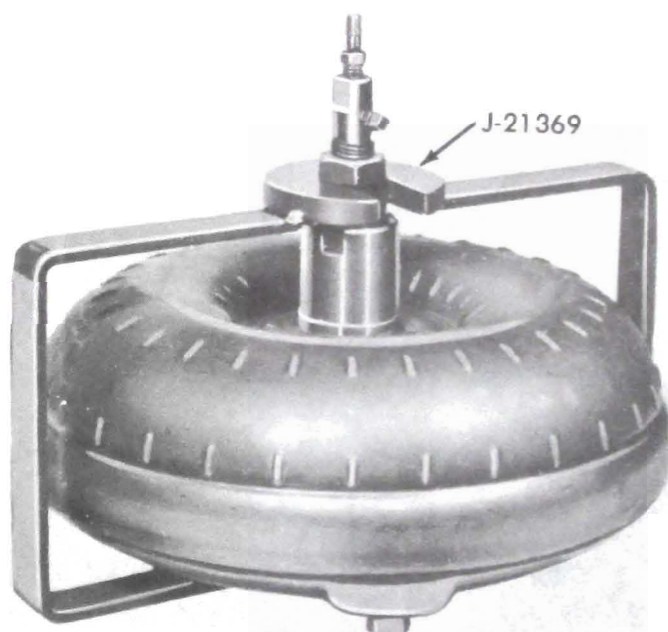

Figure 75-283

### 75-34 CONVERTER CHECKING PROCEDURE

#### A. Check Converter For Leaks as Follows:

1. Install tool J-21369 and tighten. See Figure 75-283.
2. Fill converter with air; 80 psi.
3. Submerge in water and check for leaks.

#### B. Check Converter End Clearance as Follows:

1. Install tool J-21371-2 and tighten brass nut. See Figure 75-284.
2. Install Tool J-21371-3 and tighten hex nut. See Figure 75-285.
3. Install dial indicator set at "0".
4. Loosen hex nut. See Figure 75-286. When nut is fully loosened the reading obtained on the dial indicator will be converter end clearance. If clearance is .050" or over and the oil has the appearance of



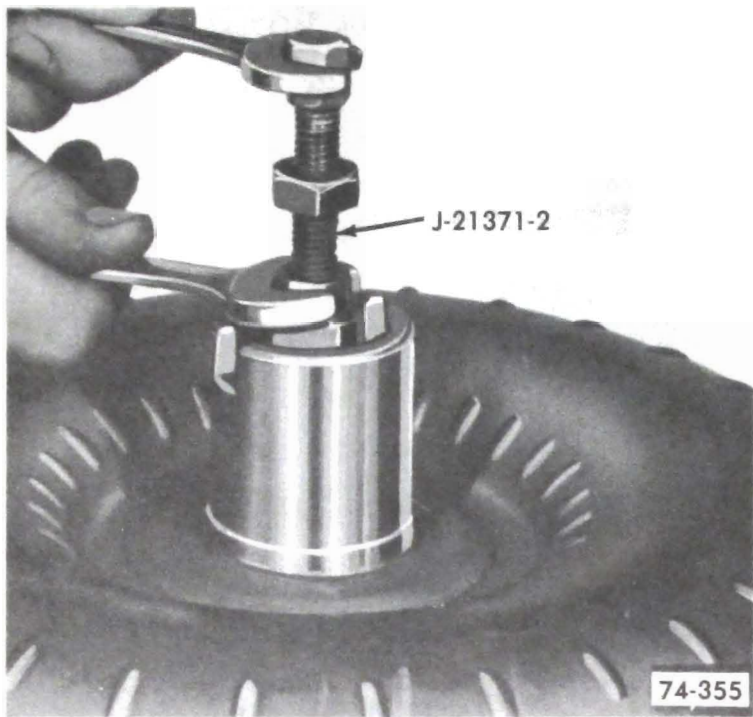

Figure 75-284

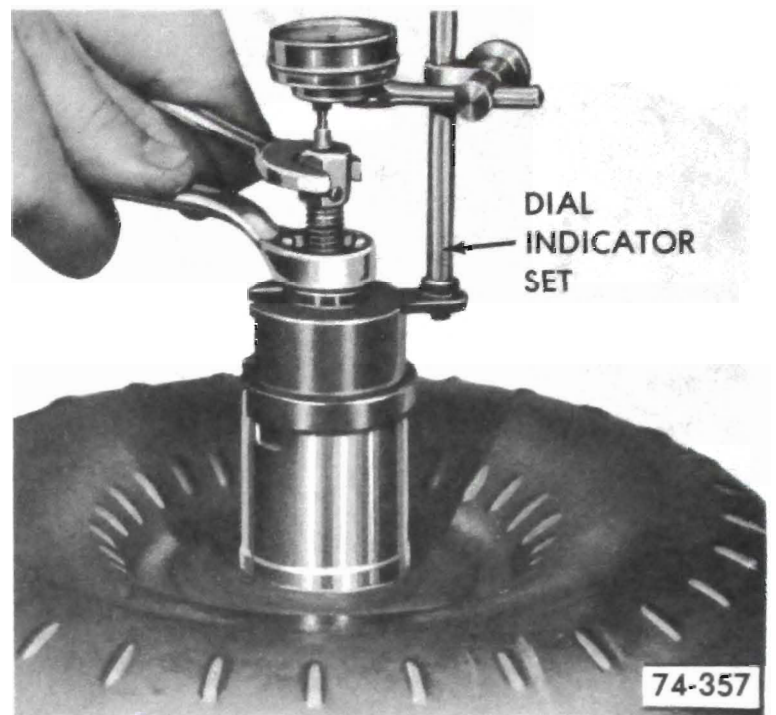

Figure 75-286

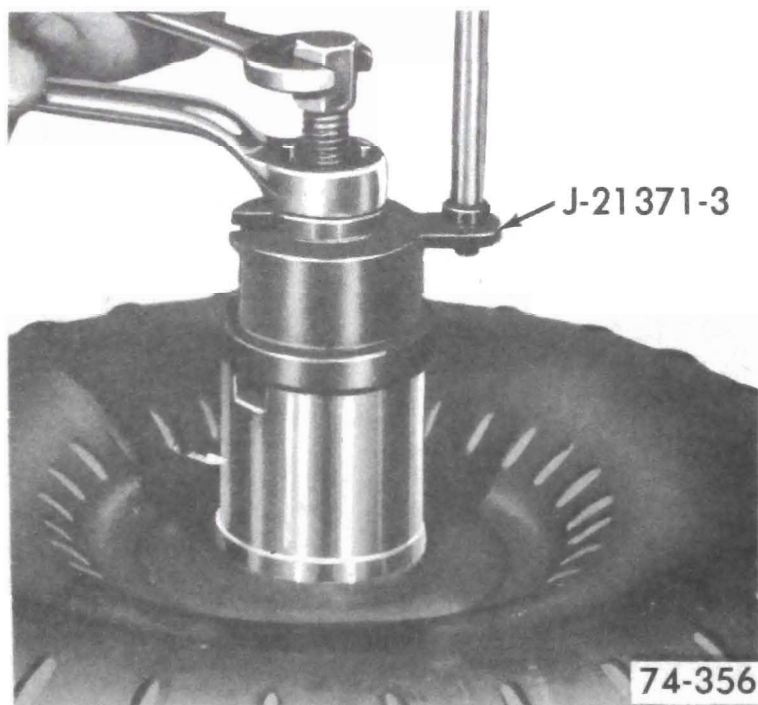

Figure 75-285

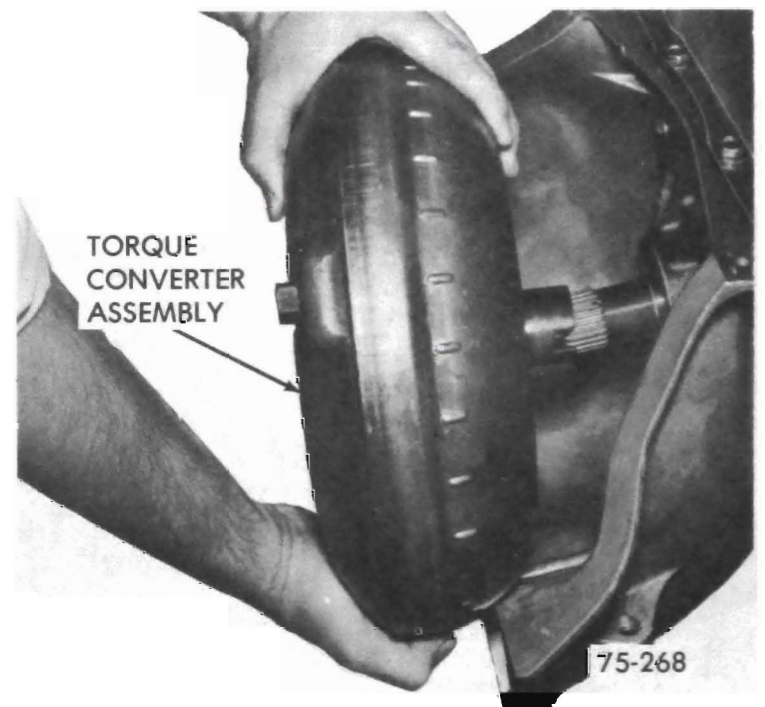

Figure 75-287

having been mixed with aluminum paint, replace the converter.

**C. Install Converter. See Figure 75-287.**

**D. Install Converter Holding Tool J-21366**

**E. Refer to Paragraph 75-36, Subparagraph D, for Refill Procedures**

### 75-35 INSTALLATION OF GOVERNOR BUSHING

1. Remove transmission from car.
2. Remove the output shaft, valve body, support plate, and governor from the case.
3. Assemble transmission case in fixture J-8763 and mount in a vise. See Figure 75-288.
4. Clean off excess stock from the governor o-ring seal to case mating surface. See Figure 75-289.

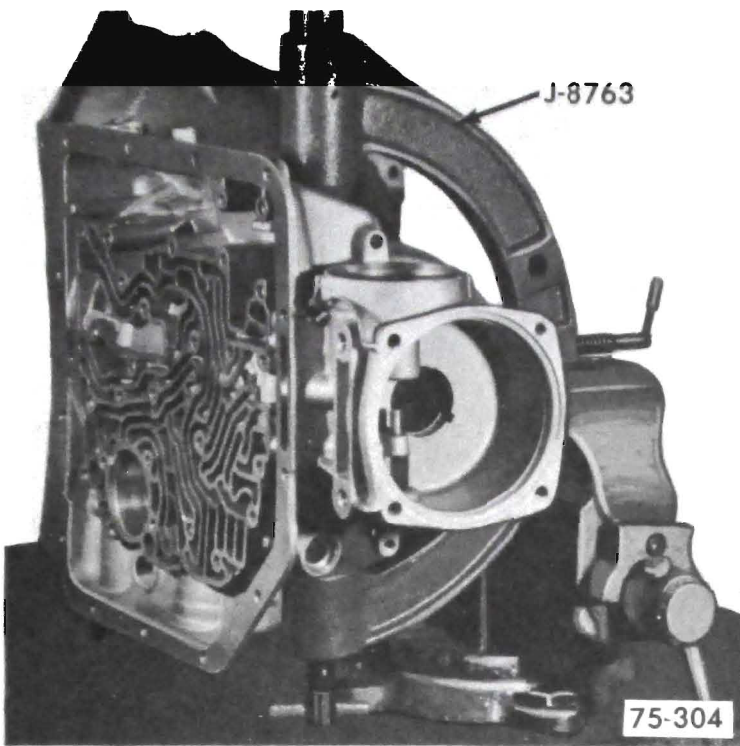

Figure 75-288

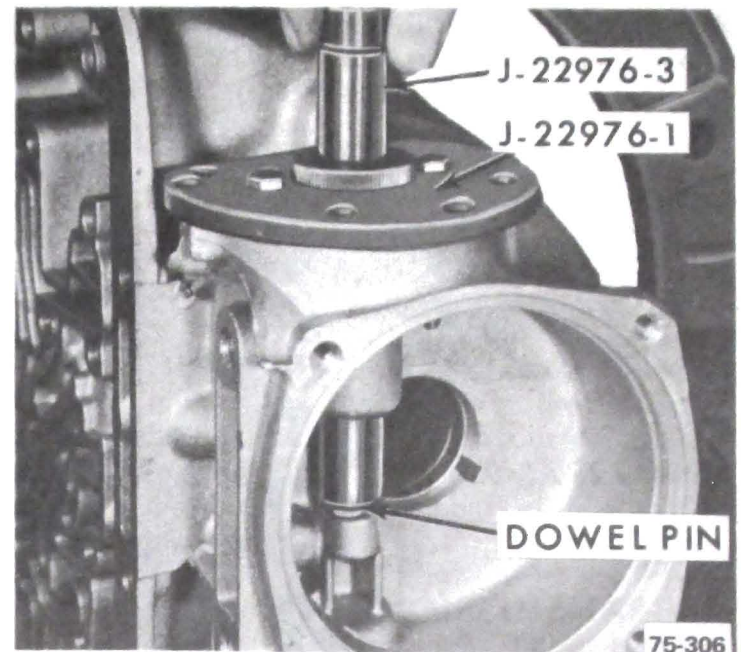

Figure 75-290

arbor cannot be rotated by hand, recheck the work performed in step 4.

8. Remove the alignment arbor.

9. Using reamer J-22976-9 and drive ratchet, *hand* ream the governor bore using the following procedure: (*Hand Ream Only* )

a. Oil the reamer, drill bushing, and governor bore.

b. Use 5-10 lbs. of feeding force on the reamer. See Figure 75-291.

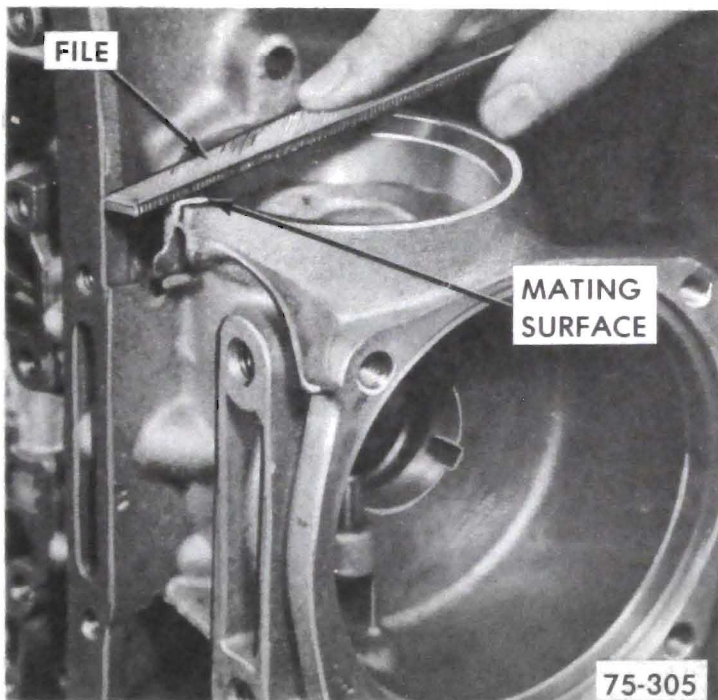

Figure 75-289

5. *Loosely* bolt the drill bushing fixture J-22976-1 to the case.

6. Place the alignment arbor J-22976-3 into the drill bushing fixture and down into the governor bore until it bottoms on the dowel pin. See Figure 75-290.

7. Torque the bolts on the drill bushing fixture 8-12 lb. ft. *Do not over torque and strip the threads.*

The alignment arbor should be able to rotate freely after the bolts are properly torqued. If the alignment

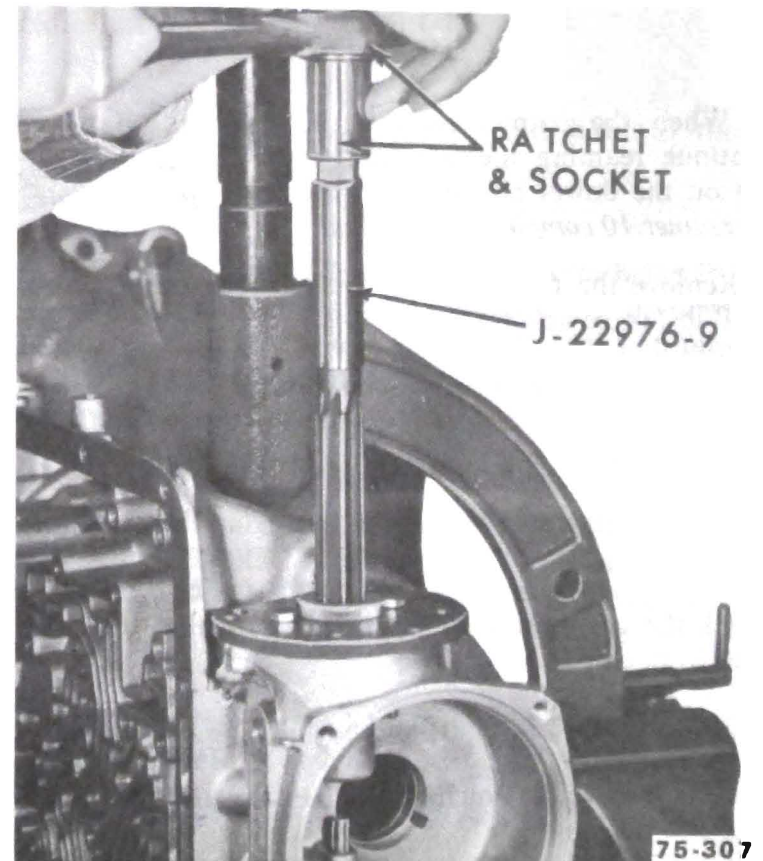

Figure 75-291



c. After each 10 revolutions remove the reamer and dip it into a cup full of transmission oil. This will clean the chips from the reamer and lubricate it. See Figure 75-292.

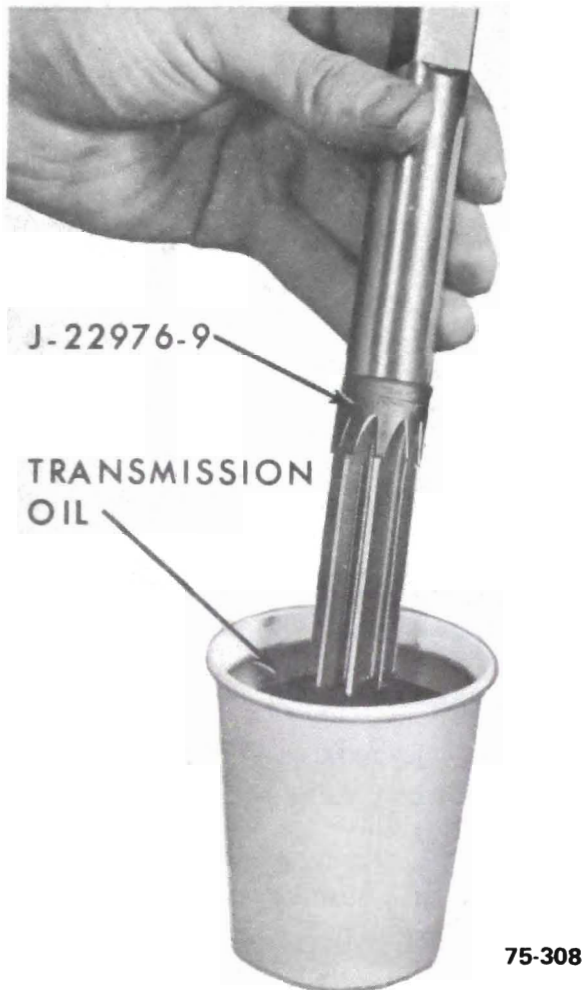

Figure 75-292

d. When the reamer reaches the end of the bore, continue reaming the bore until the reamer bottoms out on the dowel pin in the case. At this point, rotate the reamer 10 complete revolutions.

e. Remove the reamer using a clockwise rotation and 5-10 lbs. force upward.

Pulling the reamer out without rotating it may score the bore causing a leak between the case and the bushing.

10. Remove the drill bushing fixture from the case.

11. Thoroughly clean the chips from the case, visually check the governor feed holes to insure that they are free from chips.

12. Install the bushing using the following procedure:

- a. Note the two (2) notches at one end of the bushing.
- b. Position the notches so that one notch is toward the front of the case and the other is toward the bottom of the case. See Figure 75-293.

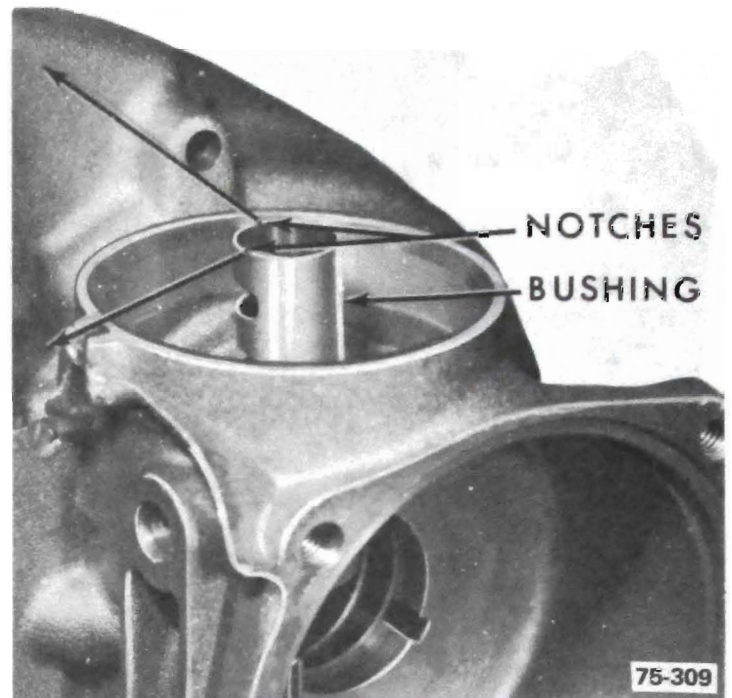

Figure 75-293

c. Use J-22976-3 alignment arbor and bushing installer to drive the bushing into the case. See Figure 75-294. A brass hammer should be used to strike the hardened steel bushing installer tool.



Figure 75-294

d. Drive the bushing until it is flush with the top of the bore. See Figure 75-295.

13. Oil a new governor and insert it into the installed bushing. The governor should spin freely. If slight honing on the bushing is necessary, use crocus or fine emery cloth and move in the annular direction only.

### C. Transmission Identification Number and Car Serial Number

A production day and shift built number, transmission model and model year are stamped on the intermediate

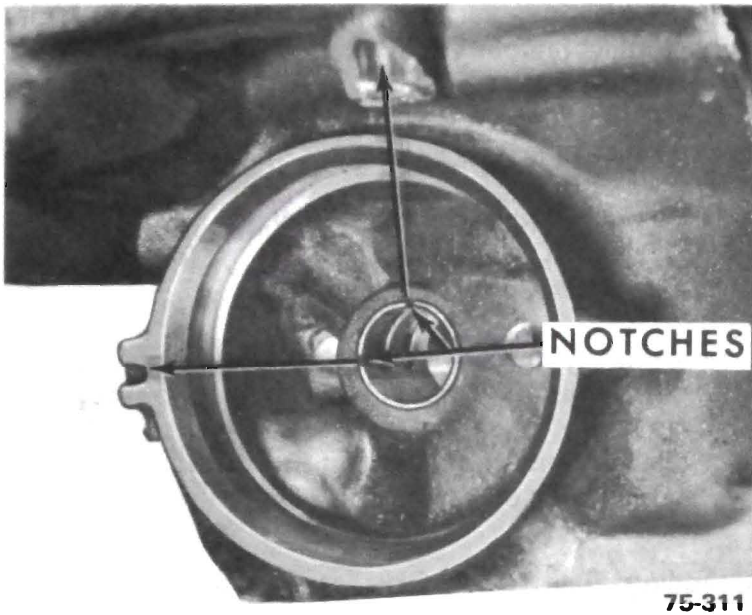

Figure 75-295

clutch accumulator cover located on the middle right side of the transmission case. See Figure 75-296. Since the production day built number and model number furnishes the key to construction and interchangeability of parts in each transmission, they should be used when selecting replacement parts as listed in the master parts list. The model number and day built number should always be furnished on *product reports, AFA forms, and all correspondence with factory concerning a particular transmission.*

On all 1971 Turbo Hydra-Matic 350-375B transmissions the car serial number is stamped on the lower left side of the transmission case, next to the manual shaft.

#### D. Turbo Hydra-Matic 350-375B Fluid Recommendations

Use DEXRON Automatic Transmission Fluid only in the Turbo Hydra-Matic 350-375B automatic transmission (GM Part No. 1050568-69-70 or any other fluid having DEXRON identifications).

The oil pan should be drained and the strainer cleaned every 24,000 miles and fresh fluid added to obtain the proper level on the dipstick. See sub-paragraph *F Draining Oil Pan and Replacing Strainer Assembly* for proper refill procedures. For cars subjected to heavy city traffic during hot weather, or in commercial use, when the engine is regularly idled for prolonged periods, the oil pan should be drained and the strainer cleaned every 12,000 miles.

#### E. Checking and Adding Fluid

Fluid level should be checked at every engine oil change. The "FULL" and "ADD" marks on the transmission dipstick indicate one (1) pint difference. To determine proper fluid level, proceed as follows:

The Turbo Hydra-Matic 350-375B transmission is designed to operate at the full mark on the dipstick at normal operating temperature (180 degrees F) and should be checked under these conditions. The normal operating temperature is obtained only after at least 15 miles of highway type driving or the equivalent of city driving.

To determine proper level, proceed as follows:

1. With manual control lever in Park position start engine. DO NOT RACE ENGINE. Move manual control lever through each range.

2. Immediately check fluid level with selector lever in PARK, engine running, and vehicle on LEVEL surface.

At this point, when a reading is made, fluid level on the dipstick should be at the "FULL" mark.

3. If additional fluid is required, add fluid to the "FULL" mark on the dipstick.

If the vehicle cannot be driven sufficiently to bring the transmission to operating temperature and it becomes necessary to check the fluid level, the transmission may be checked at room temperature (70 degrees F) as follows:

1. With manual control lever in Park position start engine. DO NOT RACE ENGINE. MOVE MANUAL CONTROL LEVER THROUGH EACH RANGE.

2. Immediately check fluid level with selector lever in Park, engine running and vehicle on LEVEL surface.



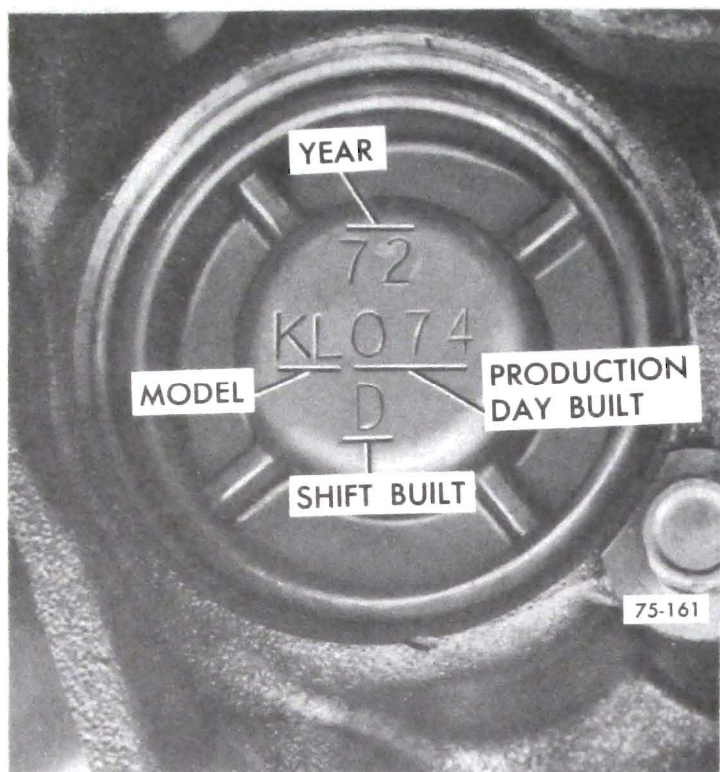

Figure 75-300 - Model Identification

At this point, when a reading is made, fluid level on the dipstick should be 1/4" below the "ADD" mark.

3. If additional fluid is required add fluid to bring level to 1/4" below the "ADD" mark on the dipstick.

If transmission fluid level is correctly established at 70 degrees F it will appear at the "FULL" mark on the dipstick when the transmission reaches normal operating temperature (180 degrees F). The fluid level is set 1/4" below the "ADD" mark on the dipstick to allow for expansion of the fluid which occurs as transmission temperatures rise to normal operating temperature of 180 degrees F.

Do not overfill, as foaming and loss of fluid through the vent pipe might occur as fluid heats up. If fluid is too low especially when cold, complete loss of drive may result which can cause transmission failure.

#### F. Draining Oil Pan and Replacing Strainer Assembly

1. Raise car on hoist or place on jack stands, and provide container to collect draining fluid.
2. Remove oil pan and gasket. Discard gasket.
3. Drain fluid from oil pan. Clean pan with solvent and dry thoroughly with clean compressed air.
4. Remove strainer assembly and clean, and discard oil strainer to valve body gasket.
5. Install new oil strainer to valve body gasket on strainer. Install strainer assembly.

6. Install new gasket on oil pan and install pan. Tighten attaching bolts to 13 lb.ft.

7. Lower car and add 3 pints of transmission fluid through filler tube.

8. With manual control lever in Park position, start engine. DO NOT RACE ENGINE. Move manual control lever through each range.

9. Immediately check fluid level with selector lever in Park, engine running, and vehicle on LEVEL surface.

10. Add additional fluid to bring level to 1/4" below the "ADD" mark on the dipstick. Do not overfill.

#### G. Adding Fluid to Fill Dry Transmission and Converter Assembly

The fluid capacity of the Turbo Hydra-Matic 350-375B transmission and converter assembly is approximately 20 pints, but correct level is determined by the mark on the dipstick rather than by amount added. In cases of transmission overhaul, when a complete fill is required, including a new converter proceed as follows:

1. Add eight pints of transmission fluid through filler tube.

The converter should be replaced only if the converter itself fails. On any major failure, such as a clutch or gearset, the strainer must be cleaned.

If installation of a new converter is not required add only five pints of transmission fluid.

2. With manual control lever in Park position start engine and place on cold idle cam. DO NOT RACE ENGINE. Move manual control lever through each range.

3. Immediately check fluid level with selector lever in Park, engine running, and vehicle on LEVEL surface.

4. Add additional fluid to bring level to 1/4" below the "ADD" mark on the dipstick. Do not overfill.

#### H. Turbo Hydra-Matic 350-375B-375B Towing Instructions

If a Buick equipped with Turbo Hydra-Matic 350-375B transmission must be towed, the following precautions must be observed:

The car may be towed safely on its rear wheels with the shift lever in neutral position at speeds of 35 miles per hour or less under most conditions.

However, the drive shaft must be disconnected or the car towed on its front wheels if

Tow speeds in excess of 35 mph are necessary,

Car must be towed for extended distances (over 50 miles) or,

Transmission is not operating properly.

If car is towed on its front wheels, the steering wheel should be secured to keep the front wheels in a straight-ahead position.

### **I. Rocking Car**

If it becomes necessary to rock the car to free it from sand, mud or snow, move the selector lever from "D" to "R" in a repeat pattern while simultaneously applying moderate pressure to the accelerator. Do not race engine. Avoid spinning wheels when trying to free the car.







IF REPLACEMENT IS REQUIRED USE  
ALUMINUM OIL SEAL RING



INTERMEDIATE SERVO PISTON AND SEAL

WASHER

APPLY PIN



SPRING SEAT



SPRING



MUST BE ASSEMBLED AS SHOWN

TEFLON OIL SEAL RING



Figure 75-296 Intermediate Servo Assembly · Exploded View



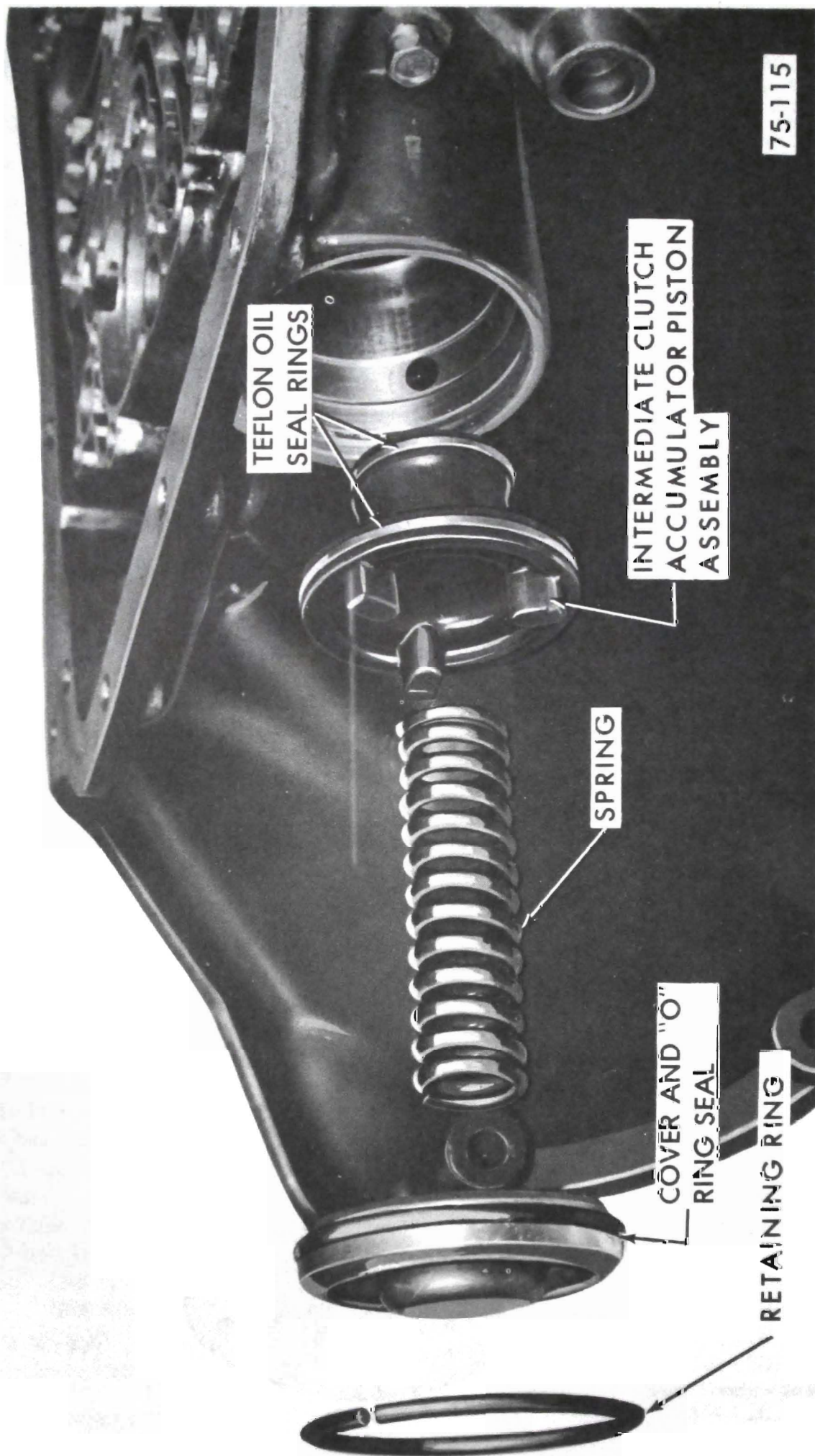

Figure 75-297 Intermediate Clutch Accumulator - Exploded View

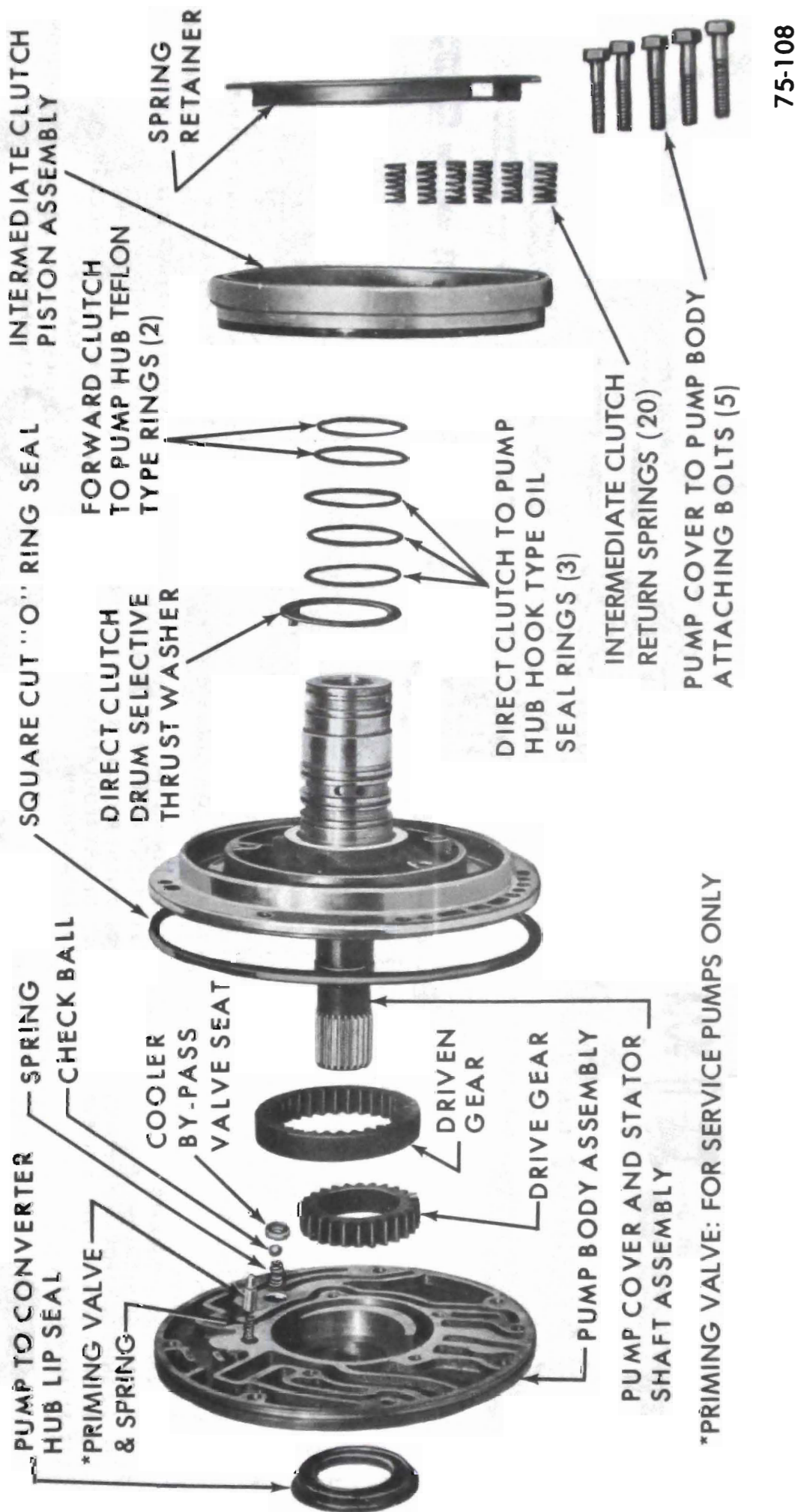

Figure 75-298 Exploded View of Oil Pump Assembly



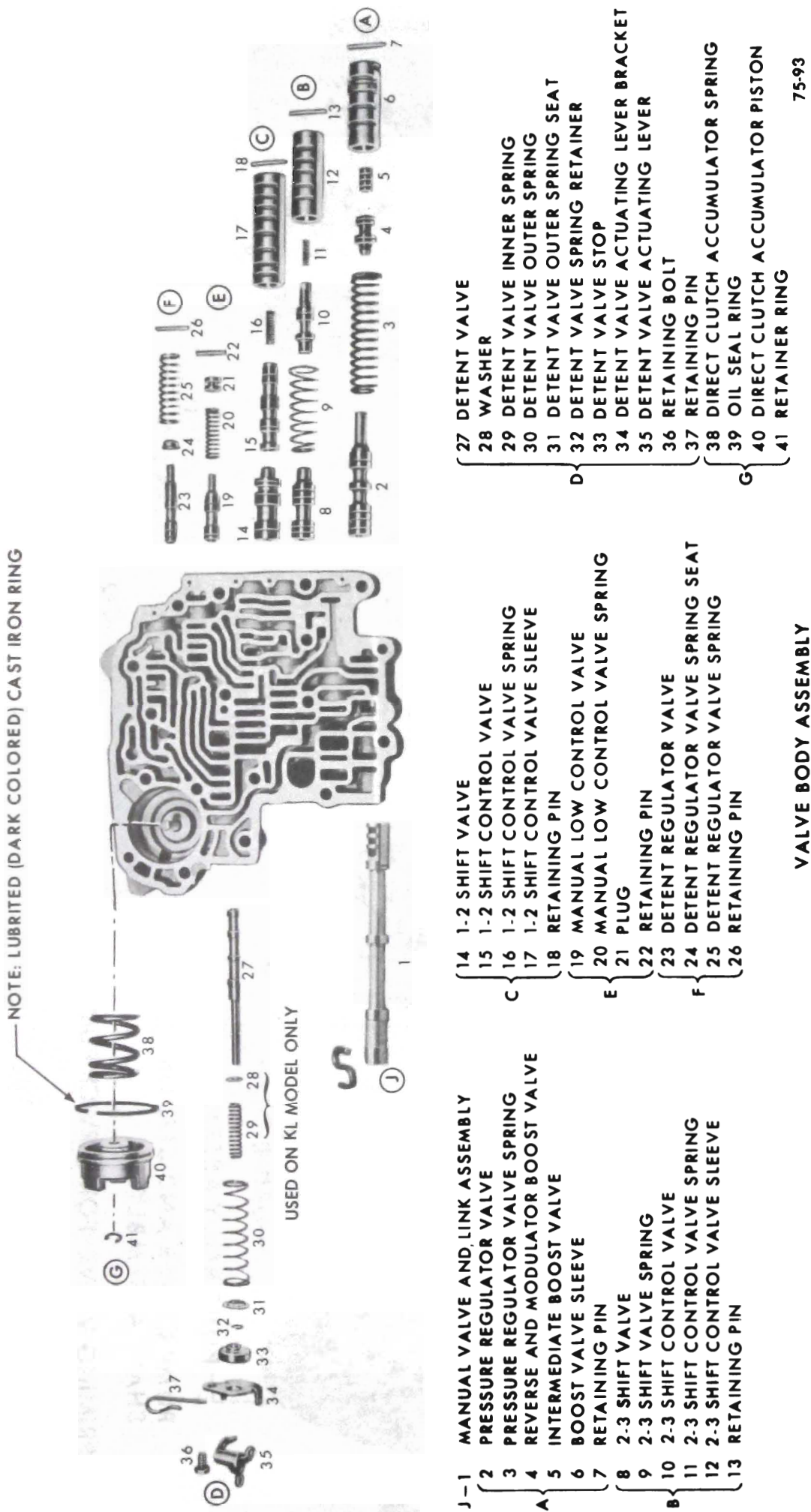

Figure 75-299 Valve Body Assembly

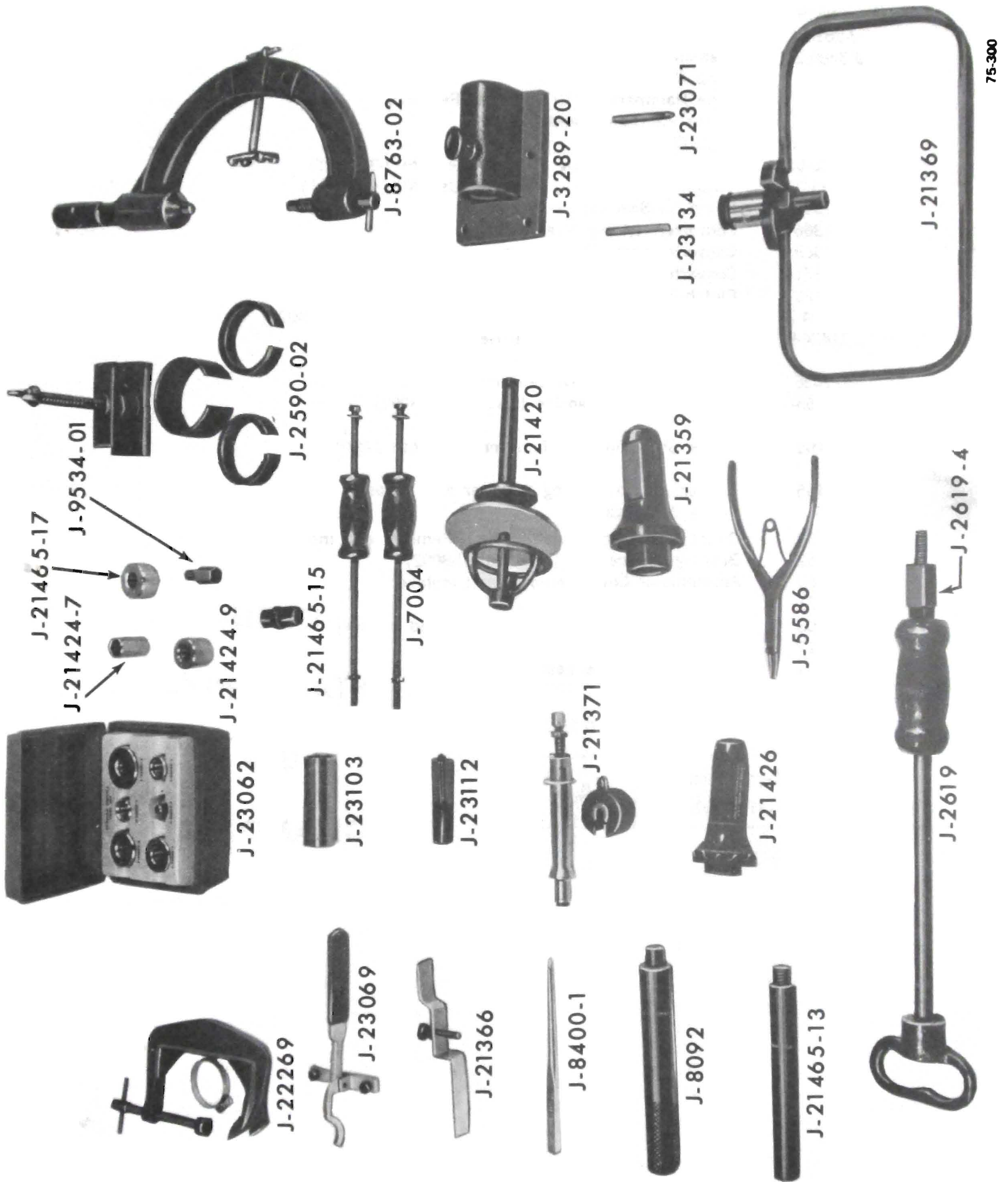

Figure 75-301 · Special Tools



J-2590-02	Clutch Spring Compressor
J-2619	Slide Hammer
J-2619-4	Slide Hammer Adapter (Included With J-2619)
J-3289-20	Transmission Holding Fixture Base
J-5586	Snap Ring Pliers
J-7004	Slide Hammers (Pr.) (For Pump Removal)
J-8092	Driver Handle (Threaded Type)
J-8400-1	Cape Chisel
J-8763-02	Transmission Holding Fixture (Use With J-3289-20)
J-9534-01	Output Shaft Bushing Remover (Use With J-7004-1)
J-21359	Pump Oil Seal Installer
J-21366	Converter Holding Strap
J-21369	Converter Leak Test Fixture
J-21371	Converter Stator and Turbine End-Play Checking Fixture
J-21420	Clutch Spring Compressor
J-21424-7	Stator Shaft Bushing Installer (Front) (Use With J-8092)
J-21424-9	Extension Housing Bushing Remover and Installer (Use With J-8092)
J-21426	Extension Housing Oil Seal Installer
J-21465-13	Driver Handle Extension (Use With J-8092)
J-21465-15	Stator Shaft Bushing Remover (Use With J-8092)
J-21465-17	Converter Hub Bushing Remover and Installer (Use With J-8092)
J-22269	Direct Clutch Accumulator Piston Remover and Installer
J-23062	Bushing Service Tool (Use With J-8092)
J-23069	Accumulator Cover Remover and Installer
J-23071	Band Apply Pin Gauge
J-23103	Propeller Shaft Yoke Seal Remover and Installer
J-23112	Pump Check Valve Seal Installer
J-23134	Pump Check Valve Seat Remover