

SECTION B**FOUR-SPEED MANUAL TRANSMISSION****4D-4F-4G-4H SERIES****CONTENTS**

Division	Subject	Page No.
I	TROUBLE DIAGNOSIS: Trouble Diagnosis	72-20
II	DESCRIPTION AND OPERATION: Description of the Four-Speed Manual Transmission	72-23
III	ADJUSTMENTS AND MINOR SERVICE: (Not Applicable)	
IV	REMOVAL AND INSTALLATION: Removal and Installation of Transmission	72-23
V	OVERHAUL AND MAJOR SERVICE: Disassembly of Transmission	72-23
	Mainshaft Assembly	72-24
	Reverse Shifter Shaft and Seal Replacement	72-27
	Transmission Case Extension Bushing and Oil Seal Removal and Replacement	72-27
	Cleaning and Inspection	72-28
	Countergear Assembly	72-28
	Side Cover - Removal and Installation	72-28
	Transmission Reassembly	72-30
VI	SPECIFICATIONS: General Specifications	72-33

DIVISION IV**TROUBLE DIAGNOSIS****72-12 FOUR-SPEED MANUAL TRANSMISSION
TROUBLE DIAGNOSIS**

Condition	Possible Cause	Correction
Shifts Hard	1. Clutch not releasing engine or slow to release.	1. Adjust or repair clutch.
	2. Shift linkage binding.	2. Free-up and adjust as required.
Shifts Hard on Downshift	1. Downshifting at too high an engine speed.	1. Shifting into low gear above 45 mph and second above 65 mph cause extra work for synchronizing assemblies and will require extra time. There is also danger of over-speeding the engine if low or second is used at high car speeds.
Disengages From Gear	1. Dirt between transmission case and clutch housing.	1. Clean mating surfaces.
	2. Does not fully engage.	2. Check linkage for interference. Adjust. See Section 73, or replace damaged shift linkage.
	3. Clutching teeth worn or defective and/or clutch hub spline worn.	3. Replace gear, clutch sleeve and clutch hub.
Noisy	1. Gears worn, scored or broken.	1. Replace gears.
	2. Bearing dirty, worn.	2. Flush transmission with kerosene. If noise is still present, TXT replace bearings and examine gears as above.
	3. Interference of clutch sleeve with countergear.	3. Replace worn shift forks, countergear and idler gear thrust washers to restore gears and clutch sleeve to proper location. Examine thrust faces on these gears for wear. Replace if worn excessively.
Leaks Lubricant	1. Excessive amount of lubricant in transmission.	1. Drain to correct level.
	2. Loose or broken main drive gear bearing retainer.	2. Tighten or replace retainer.
	3. Front main bearing retainer gasket damaged.	3. Replace gasket.
	4. Cover loose or gasket damaged.	4. Tighten cover or replace gasket.

	5. Operating shaft seal leaks.	5. Replace operating shaft seal.
	6. Countershaft loose in case.	6. Replace case.
	7. Lack of sealant on bolts.	7. Coat bolts with sealant.
	8. Worn extension oil seal.	8. Replace seal.
Excessive Backlash In All Reduction Gears	1. Worn countergear bearings.	1. Replace countergear bearings and shaft.
	2. Excessive end play in countergear.	2. Replace countergear thrust washers.
Noisy In All Reduction Gears	1. Insufficient lubricant.	1. Fill to correct level.
	2. Worn or damaged main drive gear or countergear.	2. Replace faulty or damaged gears.
Noisy In All Gears	1. Insufficient lubricant.	1. Fill to correct level.
	2. Worn countergear bearings.	2. Replace countergear bearings and shaft.
	3. Worn or damaged main drive gear and countershaft drive gear.	3. Replace worn or damaged gears.
	4. Damaged main drive gear or mainshaft ball bearings.	4. Replace damaged bearings.
	5. Damaged speedometer gears.	5. Replace damaged gears.
Noisy in High Gear	1. Damaged front main bearing.	1. Replace damaged bearing.
	2. Damaged rear bearing.	2. Replace damaged bearing.
	3. Damaged speedometer gears.	3. Replace speedometer gears.
Noisy In "Neutral" With Engine Running	1. Damaged front main bearing.	1. Replace damaged bearing.
	2. Damaged mainshaft pilot bearing.	2. Replace damaged bearing.

DIVISION II

DESCRIPTION AND OPERATION

72-14 DESCRIPTION AND OPERATION OF THE G.S. AND G.S. STAGE 1 4-SPEED MANUAL TRANSMISSION

The G.S. will have as optional equipment a four-speed manually-operated transmission. All four forward gears are provided with synchronizing assemblies, see Figure 72-59, which can be engaged while the car is in motion. Closely spaced gear ratios provide excellent ratio matching with minimum loss of engine speed at shift points.

Reverse gear is not synchronized; therefore, vehicle must be brought to a complete stop before engaging reverse gear.

Power flow in all gears is shown in Figure 72-60.

DIVISION IV

REMOVAL AND INSTALLATION

72-15 REMOVAL AND INSTALLATION OF TRANSMISSION

A. Removal

1. Disconnect speedometer cable and remove driven gear.
2. Disconnect shift controls from transmission.
3. Remove propeller shaft.
4. Support rear of engine and remove transmission support.
5. Remove the two (2) top transmission to flywheel housing bolts and insert guide pins.
6. Remove two (2) lower transmission to flywheel housing attaching bolts.
7. Slide transmission straight back on guide pins until main drive gear is free of splines in clutch driven plate. If guide pins are not used damage to the clutch driven plate can result.
8. Remove transmission.

B. Installation

1. Install guide pin in upper and lower right

transmission to flywheel housing bolt holes for alignment and place transmission on guide pins. Place transmission in third gear and rotate transmission mainshaft as necessary to start main drive gear into clutch driven plate. If guide pins are not used, damage to clutch driven plate can result.

2. Install two (2) lower transmission mounting bolts. Remove guide pin and install two (2) upper bolts. Torque bolts to 45 to 60 lb.ft.
3. Install transmission support.
4. Install propeller shaft.
5. Install speedometer driven gear, and connect speedometer cable.
6. Connect linkage and adjust as described in Group 73.

DIVISION V

OVERHAUL AND MAJOR SERVICE

72-16 DISASSEMBLY OF TRANSMISSION

1. Remove side cover attaching bolts. Remove side cover assembly and gasket. Drain lubricant.
2. Remove two (2) bolt lock strips from main bearing retainer. Remove front main bearing retainer and gasket.
3. Remove main drive gear retaining nut. See Figure 72-40 using Tool J-933.

Retaining nut has lefthand threads. Aid removal of retaining nut by locking up transmission. This can best be accomplished by placing transmission in two gears at once.

4. With transmission gears in neutral, drive lock pin from bottom side of reverse shifter lever boss and pull shaft out about 1/8". This disengages the reverse shift fork from reverse gear. See Figure 72- 41.
5. Remove six bolts attaching case extension to rear bearing retainer. Tap extension with soft hammer in a rearward direction to start. When the reverse idler shaft is out as far as it will go, move extension to left so reverse fork clears reverse gear and remove extension and gasket.
6. Remove rear section of reverse idler gear, shaft and tanged thrust washer.
7. Install speedometer gear, removing Tool J-21427 and J-9578 on output shaft and remove speedometer gear.

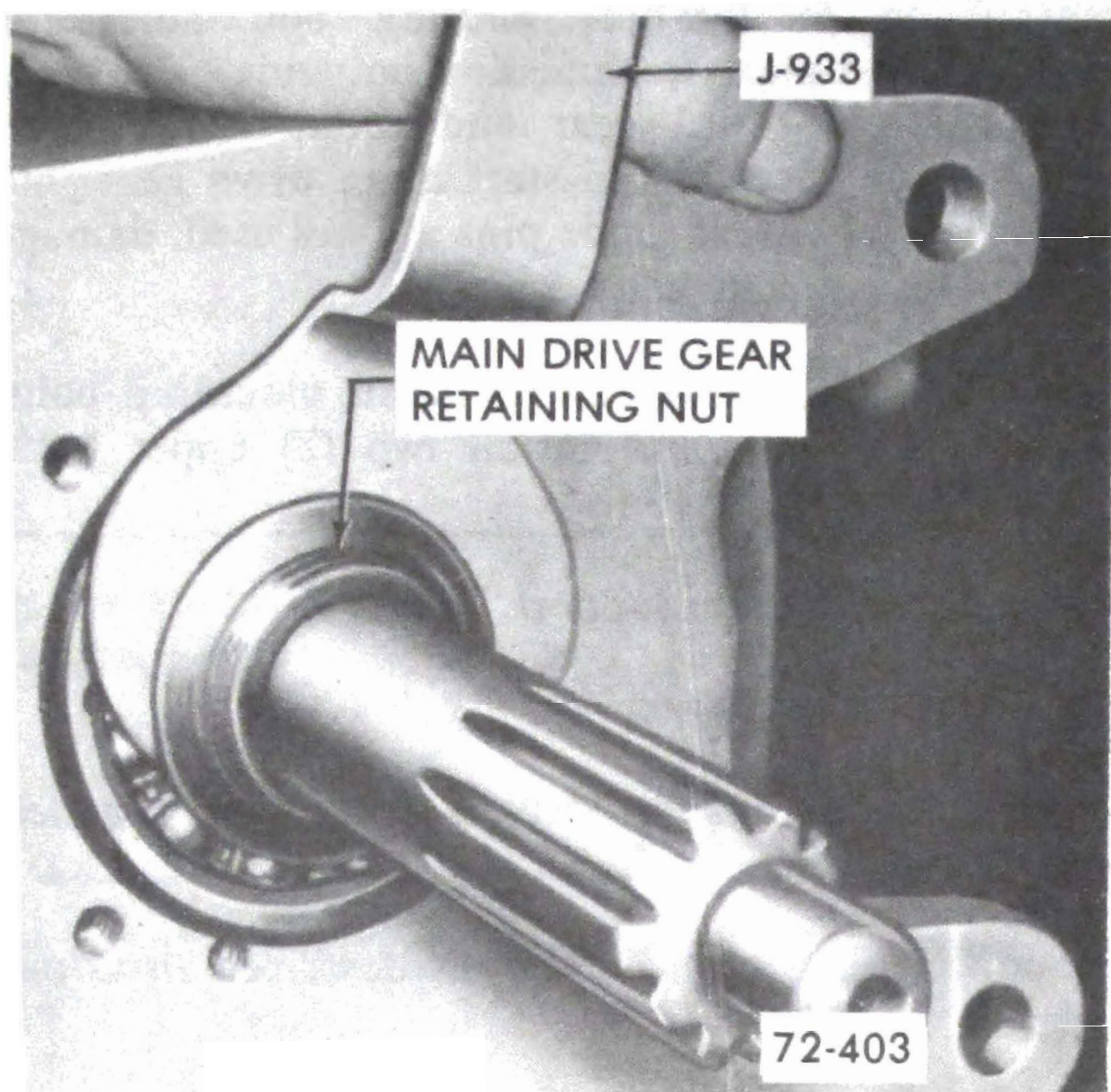

Figure 72-40 - Removing Main Drive Gear Retaining Nut



Figure 72-41 - Removing Shifter Shaft Lock Pin

8. Remove reverse gear.

9. Slide third-fourth synchronizer sleeve to fourth speed position (forward).

10. Carefully remove rear bearing retainer and entire mainshaft assembly from case by tapping bearing retainer with a soft hammer.

11. Unload 17 needle roller bearings and cage from

main drive gear and remove fourth speed blocking ring.

12. Lift the front reverse idler gear and thrust washer from case.

13. With soft hammer, tap main drive gear down from front bearing as shown in Figure 72-43.

14. From inside case, tap out front bearing and snap ring.

15. From front of case, tap out countershaft, using countershaft alignment tool J-22246 as shown in Figure 72-44. Remove the countergear and both tanged washers.

72-17 MAINSHAFT ASSEMBLY

A. Disassembly - Refer to Figure 72-45

1. Remove mainshaft front snap ring. See Figure 72-46 and remove third-fourth speed synchronizing assembly by holding synchronizing assembly and tapping front of mainshaft with a plastic hammer. Remove third speed gear and blocking ring from front of mainshaft.

2. Spread rear bearing retainer snap ring and press mainshaft out of retainer. See Figure 72-47.

3. Remove rear bearing snap ring. Support second speed gear and press on rear of mainshaft to remove shaft from rear bearing, first speed gear and sleeve, first speed blocking ring, first-second synchronizer

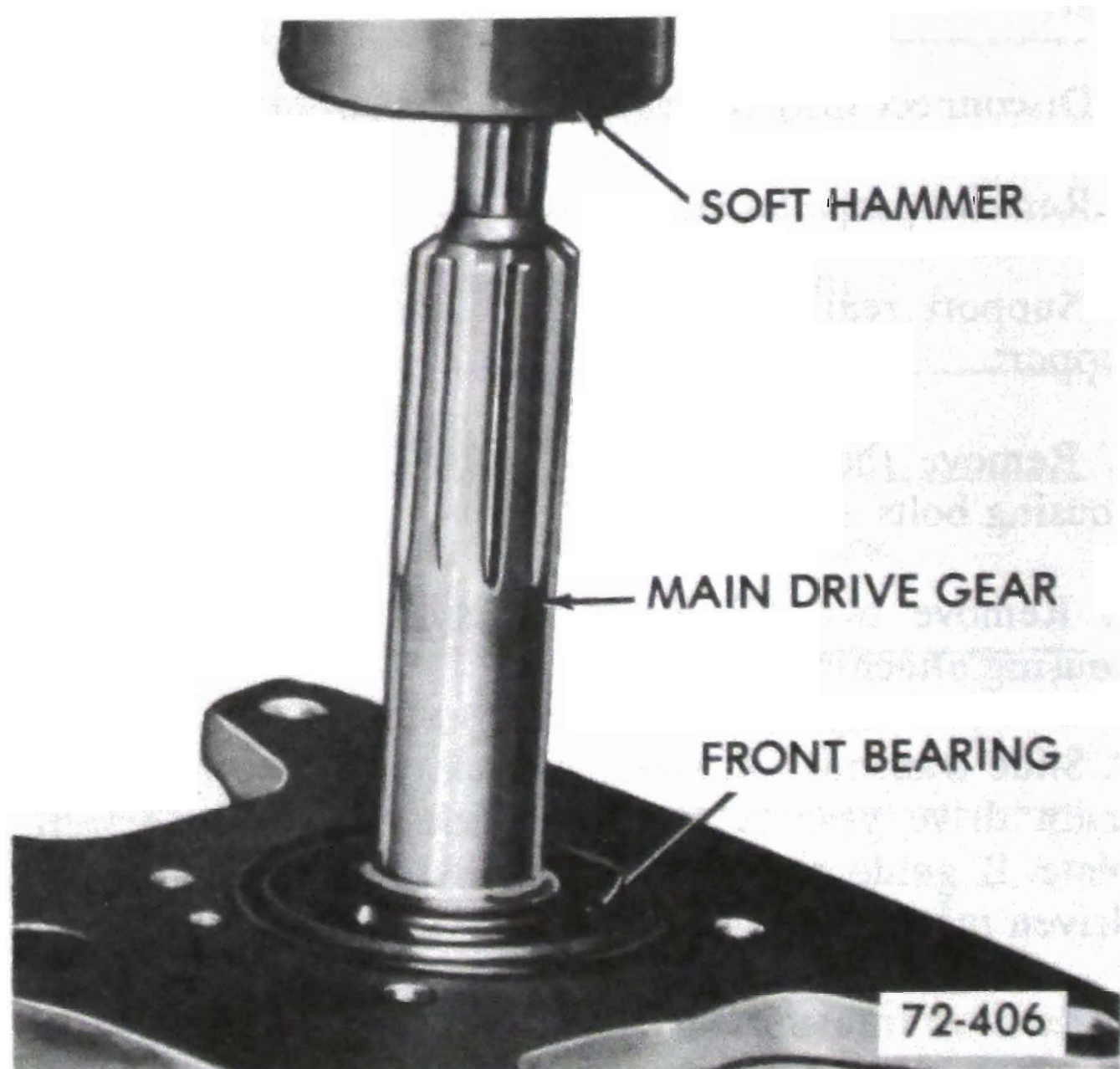

Figure 72-43 - Removing Main Drive Gear

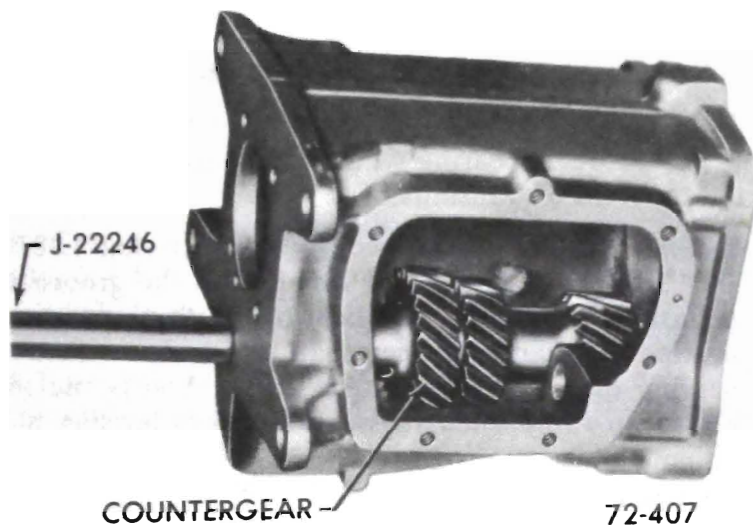

Figure 72-44 - Removing Countergear With Tool J-22246

assembly, second speed blocking ring, and second speed gear.

B. Inspection

1. Wash the front and rear bearings thoroughly in a suitable cleaning solvent.

2. Blow out bearings with compressed air. Do not allow the bearings to spin, but turn them slowly by hand. Make certain bearings are clean, then lubricate with light engine oil and check for roughness by slowly turning the race by hand.

3. Check synchronizer hubs, sliding sleeves, sliding keys and springs and, if necessary, replace as follows:

The synchronizer hubs and sliding sleeves are a selected assembly and should be kept together as originally assembled. The keys and springs may be replaced if worn or broken.

a. Mark hub and sleeve so they can be reassembled in the same position.

The sleeve with the chamfered edge opposite fork slot identifies the third-fourth synchronizer sleeve.

b. Remove sliding sleeve from synchronizer hub.

c. Place three (3) keys and two springs in position (one on each side of hub) so all three (3) keys are engaged by both springs. Synchronizer springs should be installed so tanged end of each spring falls into the same key in the hub. Slide the sleeve onto the hub aligning the marks made at disassembly.

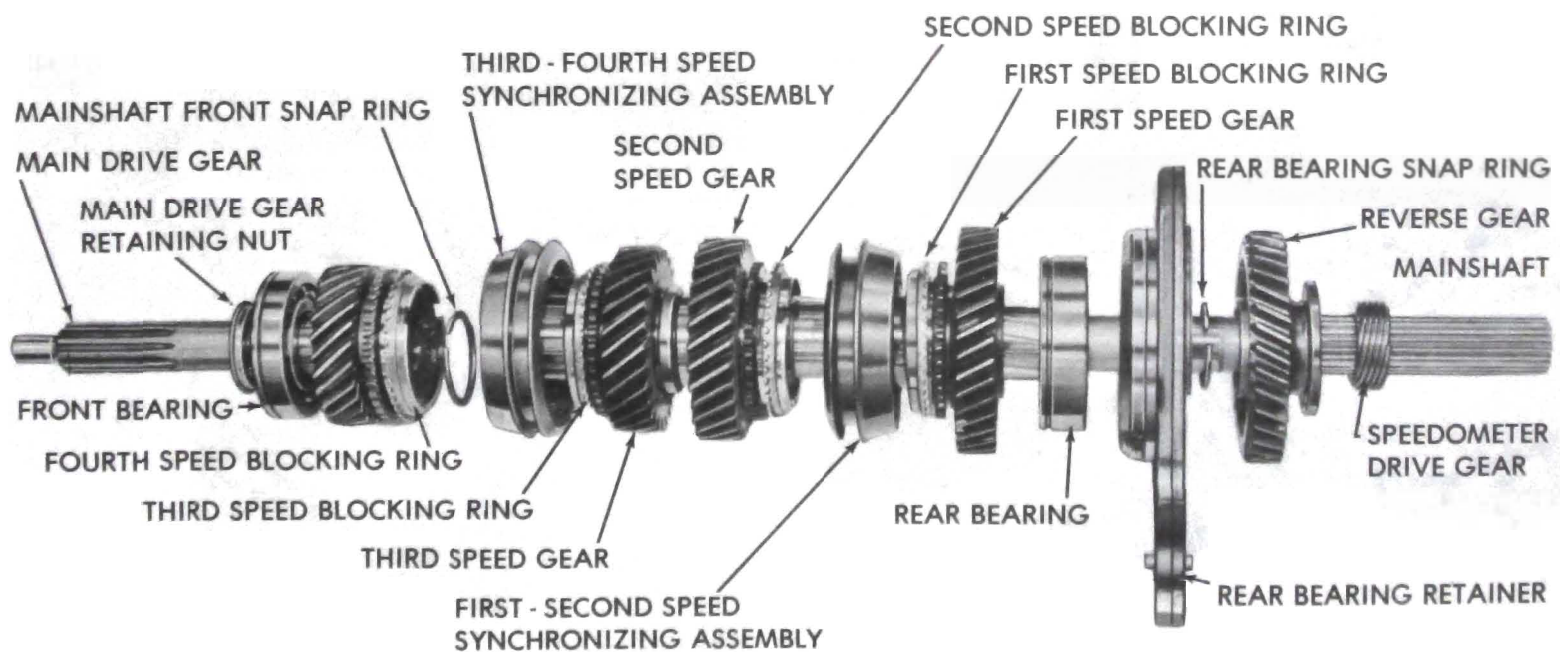

Figure 72-45 - Exploded View of Main Shaft Assembly

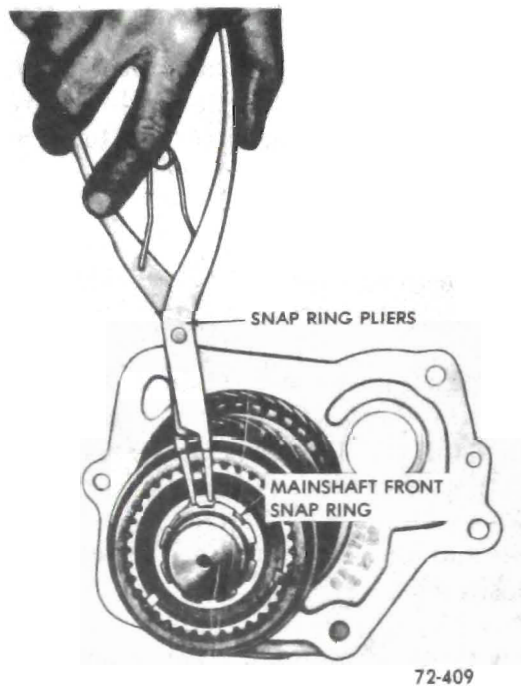

Figure 72-46 - Removing Main Shaft Front Snap Ring

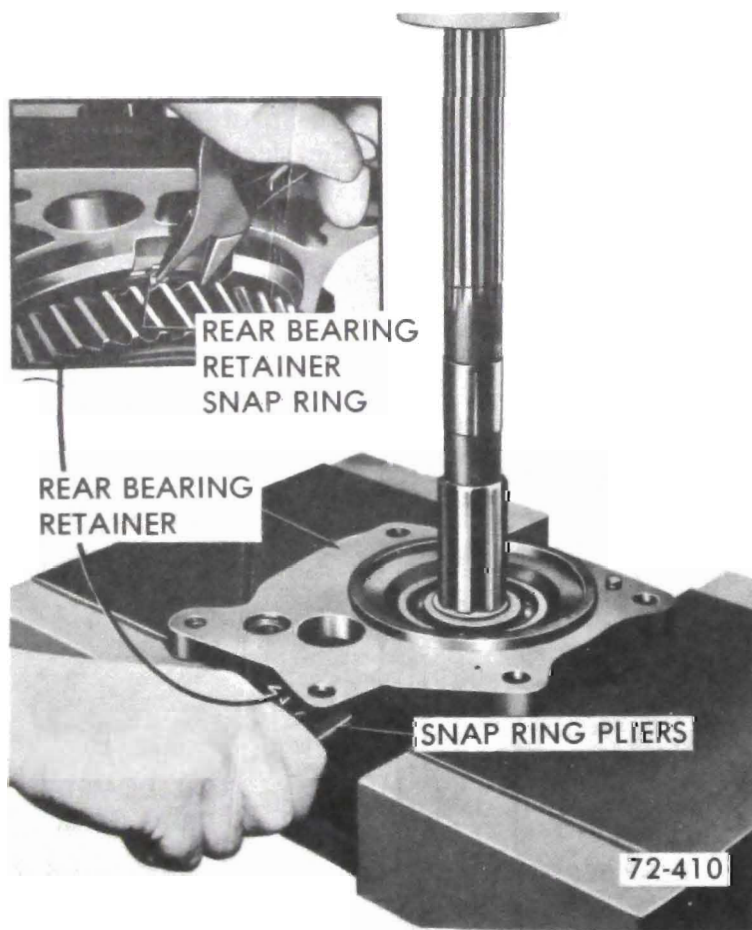

Figure 72-47 - Removing Rear Bearing From Retainer

C. Assembly - Refer to Figure 72-45

1. From rear of mainshaft, assemble second speed gear (with hub of gear toward rear of shaft).

2. Install first-second speed synchronizer assembly onto mainshaft (sliding sleeve taper toward the rear, fork slot toward front), together with a blocking ring on either side so their keyways line up with the clutch keys. See Figure 72-48.

3. Press first gear sleeve onto mainshaft.

4. Install first speed gear (with hub toward front). Press on rear bearing with the snap ring groove toward front of transmission.

5. Choose the correct selective fit snap ring (.087", .090", .093", or .096") and install it in the groove in mainshaft behind the rear bearing. With proper ring, maximum distance between snap ring and rear face of bearing must be from zero to .005". Always use the new snap rings when reassembling transmission and do not expand the snap ring further than is necessary for assembly.

6. Install third speed gear (hub to front of transmission) and third speed gear blocking ring (notches to front of transmission).

7. Install third-fourth speed gear synchronizing assembly with fork slot toward the rear of transmission making certain keys in hub correspond to notches in third speed gear blocking ring. Make certain sleeve with chamfered edge opposite fork groove is used for the third-fourth synchronizing assembly.

8. Install snap ring in groove in mainshaft in front of third-fourth speed synchronizing assembly, with ends of snap ring seated behind spline teeth.

9. Install rear bearing retainer. Spread snap ring in rear bearing retainer to allow snap ring to drop around rear bearing. Press on end of mainshaft until snap ring engages groove in rear bearing.

10. Install reverse gear, sleeve taper to rear.

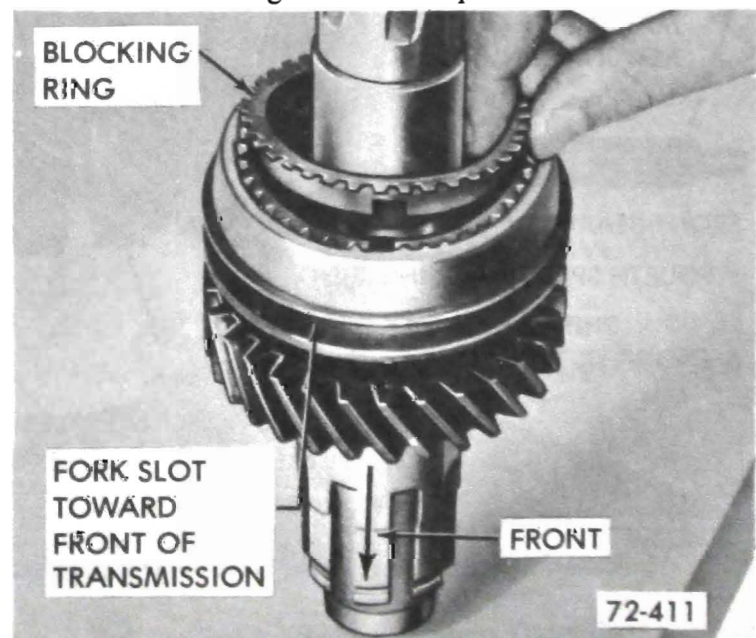

Figure 72-48 - Installing Blocking Ring

11. Install speedometer drive gear. Press to $6\text{-}53/64''$. See Figure 72-49.

72-18 REVERSE SHIFTER SHAFT AND SEAL - REMOVE AND REPLACE

1. With case extension removed from transmission the reverse shift shaft lock pin will already be removed.
2. Remove shift fork.
3. Carefully drive shift shaft into case extension allowing ball detent to drop into case. Remove shaft and ball detent spring.
4. Place ball detent spring into detent spring hole and from inside of extension, install shifter shaft fully into its opening until the detent plate is butted against inside of extension housing.
5. Place detent ball on spring, while holding ball down with a suitable tool, push the shift shaft into place and turn until the ball drops into place in detent on shaft detent plate. See Figure 72-50.
6. Install shift fork.

Do not drive shifter shaft lock pin into place until case extension has been installed on transmission case.

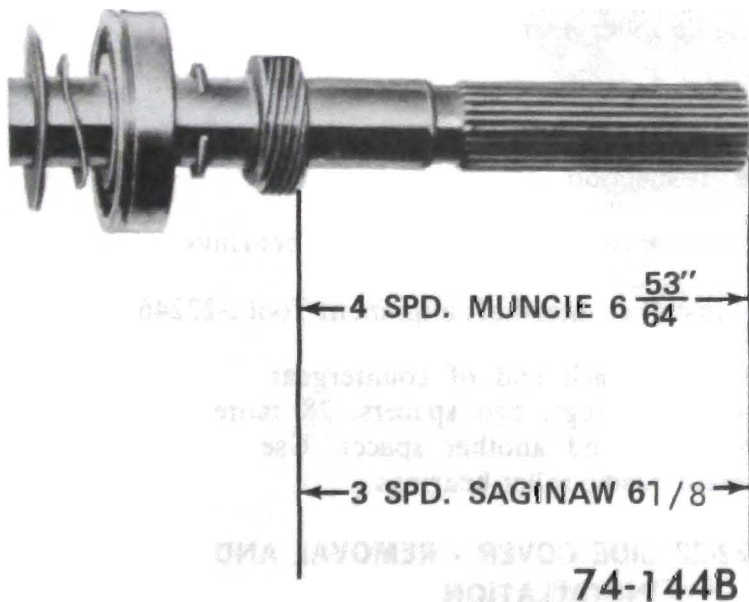

Figure 72-49 - Installing Speedometer Drive Gear

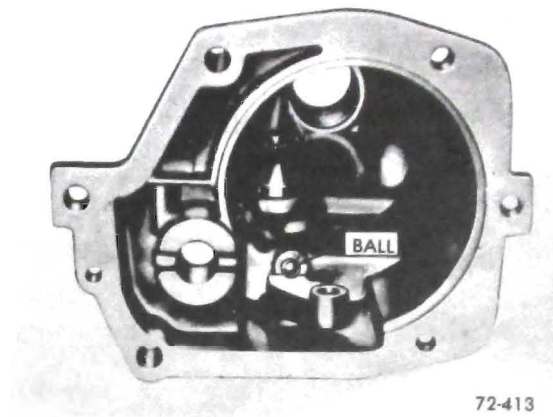

Figure 72-50 - Installing Reverse Shifter Shaft

72-19 TRANSMISSION CASE EXTENSION BUSHING AND OIL SEAL - REMOVAL AND REPLACEMENT

A. Removal

1. Using J-2619 slide hammer and J-4830-02 puller, remove case extension oil seal. See Figure 72-51.
2. Using J-2619 Slide Hammer and J-4830-02 Puller, remove case extension bushing. See Figure 72-52.

B. Replacement

1. Drive new bushing in from rear of case extension with J-6403-1.
2. Coat I.D. of bushing with transmission oil and new seal with sealing compound and start straight in bore of case extension. Using installer J-6403-1 and J-6403-2 tap seal into extension case. Flat side of J-6403-2 must be toward rear of J-6403-1. See Figure 72-53.

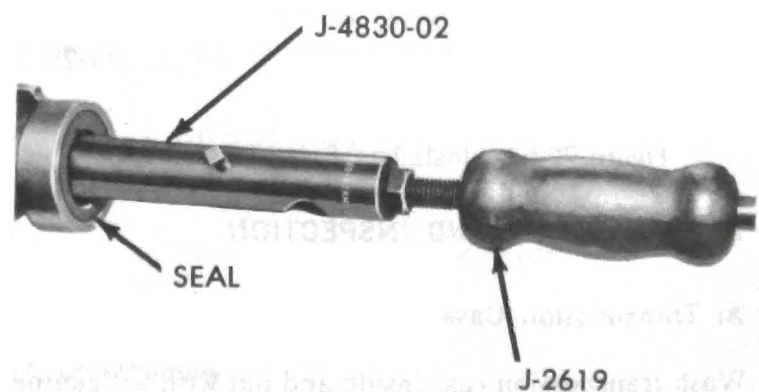

72-25

Figure 72-51 - Removing Case Extension Oil Seal

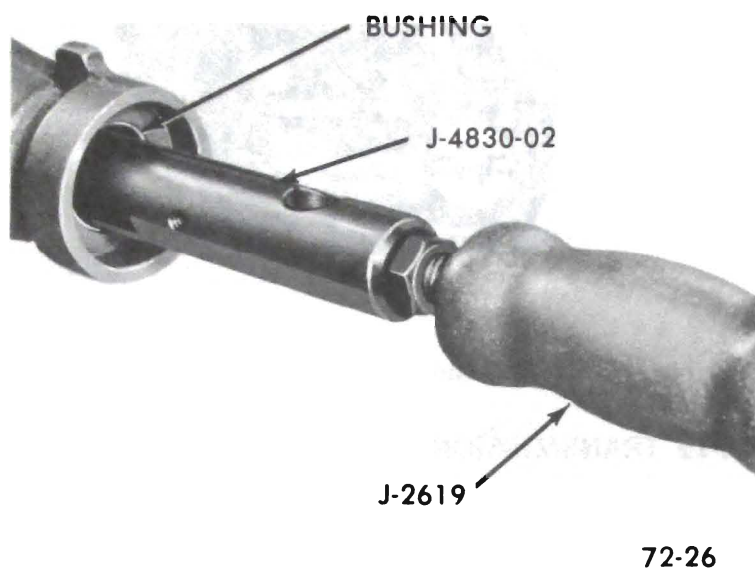

Figure 72-52 - Removing Case Extension Bushing

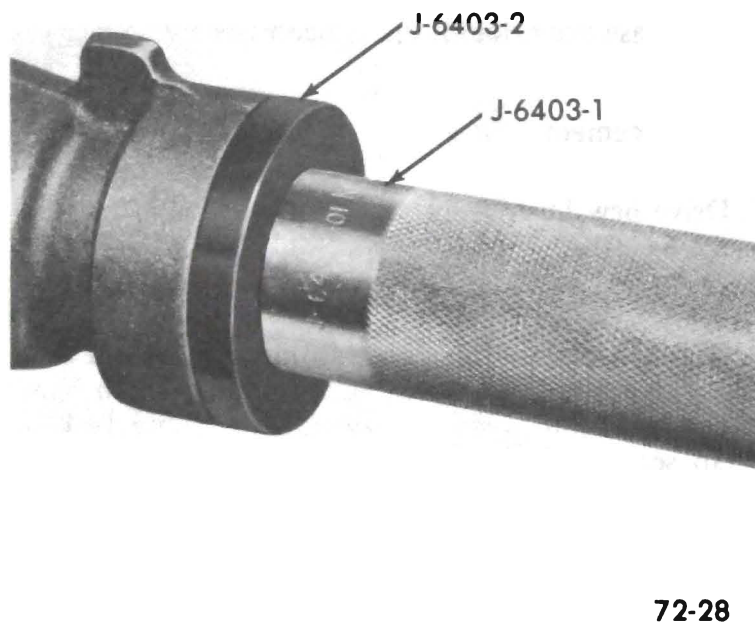

Figure 72-53 - Installing Extension Oil Seal

72-20 CLEANING AND INSPECTION

A. Transmission Case

Wash transmission case inside and out with a cleaning solvent and inspect for cracks. Make certain magnet in bottom of case is clean. Inspect front face which fits against clutch housing for burrs and if any are present, dress off with a fine cut mill file.

B. Needle Roller Bearing and Spacers

All main drive gear and countergear needle roller bearings should be inspected closely and replaced if they show wear. Inspect countershaft at the same time and replace if necessary. Replace all worn spacers.

C. Gears and Bushing

Inspect all gears and first speed gear bushing and, if necessary, replace all that are worn or damaged.

D. Reverse Idler

1. The bushings used in the idler gears are pressed into gear, then peened into holes in the bores, and then bored in place. This insures positive alignment of bushings and their shafts, as well as proper meshing of gears. Because of the high degree of accuracy to which these parts are machined, the bushings are not serviced separately.

2. Check bushings for excessive wear by using a narrow feeler gauge between the shaft and the bushing or use a micrometer. The proper clearance is from .003" to .005".

72-21 COUNTERGEAR ASSEMBLY (SEE FIGURE 72-54)

A. Disassembly

1. Remove countershaft alignment Tool J-22246.
2. From each end of countergear remove one spacer, 28 needle roller bearings, two spacers, and 28 more needle roller bearings.
3. Remove roller spacer.

B. Inspection

1. Check for broken needle roller bearings.
2. Install countershaft alignment Tool J-22246.
3. From each end of countergear install 28 needle roller bearings, two spacers, 28 more needle roller bearings, and another spacer. Use heavy grease to retain needle roller bearings.

72-22 SIDE COVER - REMOVAL AND INSTALLATION

A. Removal

It is not necessary to remove transmission from vehicle for inspection or replacement of parts in transmission side cover assembly, but the side cover assembly itself must be removed from transmission case. See Figure 72-55.

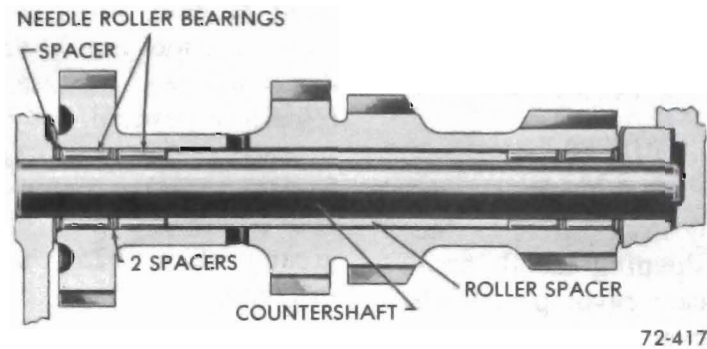
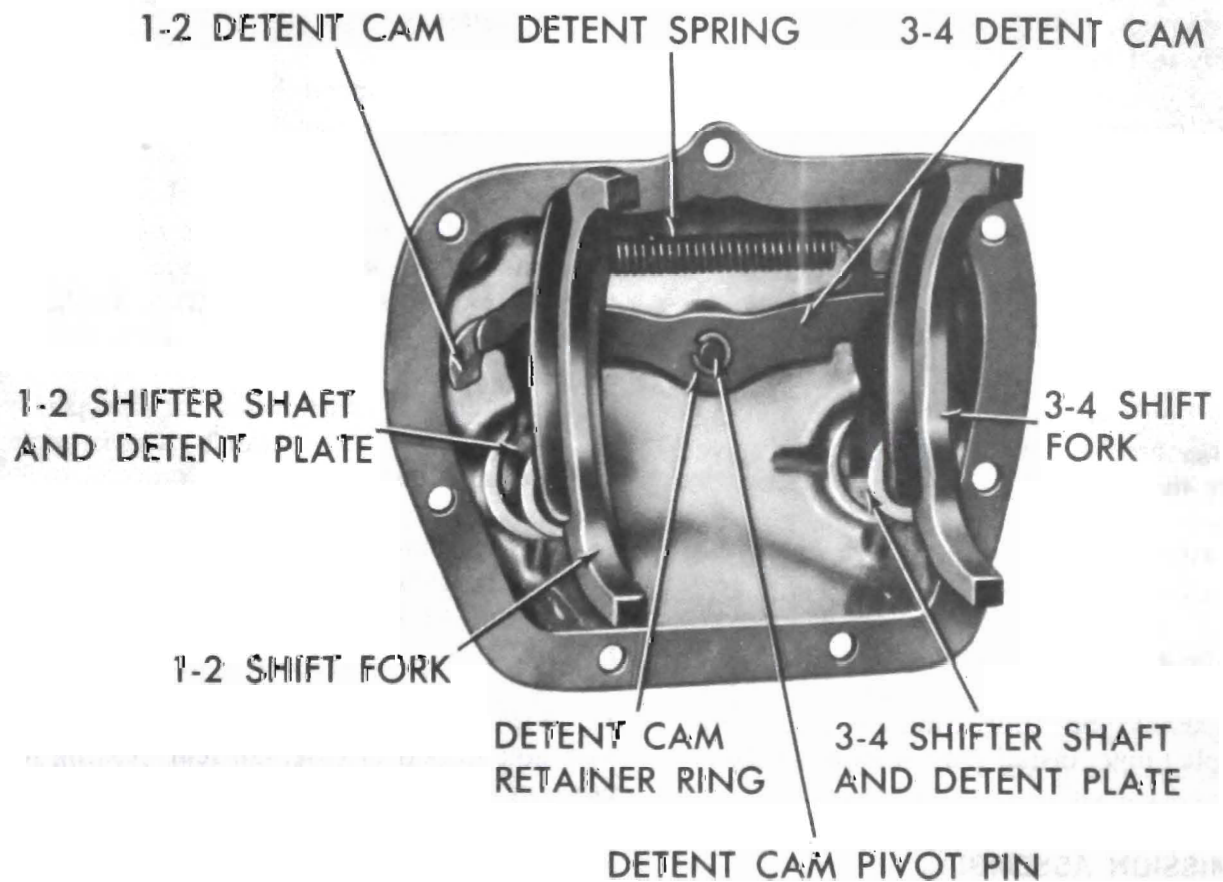

Figure 72-54 - Exploded View of Countergear



72-418

Figure 72-55 - Side Cover Assembly

1. Loosen side cover bolts to allow transmission to drain.
2. Disconnect shift controls from transmission.
3. Remove transmission side cover assembly from transmission case.

B. Disassembly

1. Remove the outer shift lever nuts and lock washers and pull levers from shafts.
2. Remove both shift forks from shifter shaft assemblies. Remove both shifter shaft assemblies from

cover. If replacement is required remove shifter shaft ring seals.

3. Remove detent cam spring and detent cam retainer ring. Remove both detent cams.

4. Inspect and replace damaged parts.

C. Reassembly

1. With detent spring tang projecting up over the second-third shifter shaft cover opening install first-reverse detent cam onto detent cam pivot pin. With detent spring tang projecting up over the first-reverse shifter shaft cover hole install second-third detent cam.

2. Install detent cam retaining ring to pivot shaft, and hook spring into detent cam notches.

3. Install both shifter shaft assemblies in cover being careful not to damage seals. Install both shift forks to shifter shaft assemblies, lifting up on detent cam to allow forks to fully seat into position.

4. Install outer shifter levers, flat washers, lock washers and bolts.

D. Installation

1. Shift shifter levers into neutral detent (center) position. Position cover gasket on case.

2. Carefully position side cover into place making certain shift forks are aligned with their respective mainshaft sliding sleeves.

3. Install cover attaching bolts and tighten evenly to 14-22 lb.ft.

4. Remove filler plug at side of transmission and add 3 pints of SAE 80 Multi-Purpose Gear Lubricant. Lubricant level should be approximately level with bottom of filler plug hole. Install plug. Torque to 25-35 lb.ft.

72-23 TRANSMISSION ASSEMBLY

1. Rest transmission case on its side with side cover opening toward assembler. Install countergear tanged thrust washers in place, retaining them with heavy grease, making certain tangs are resting in notches in case.

2. Place countergear in bottom of transmission case, making certain that tanged thrust washers are not moved out of position.

3. Lubricate and insert countershaft in rear of case. Turn countershaft so flat on end of shaft is horizontal and facing bottom of case. The flat on shaft must be

horizontal and toward bottom of transmission to mate with rear bearing retainer when installed.

4. Align countergear with shaft in rear and hole in front of case. Press countershaft into case (pushing alignment tool out front of case) until flat on shaft is flush with rear of case. Make certain thrust washers remain in position. See Figure 72-56.

5. Attach a dial indicator as shown in Figure 72-57 and check end play of countergear. If end play is greater than .025" new thrust washers must be installed.

6. Install case and seventeen needle roller bearings into main drive gear, using heavy grease to hold the bearings and cage in place.

7. Install main drive gear through side cover opening and into position in transmission front bore.

8. Place gasket in position on front face of rear bearing retainer.

9. Install fourth speed blocking ring on main drive gear with notches toward rear of transmission.

10. Position reverse idler gear thrust washer (tanged) on machined face of ear cast in case for reverse idler shaft and hold with heavy grease. Position front reverse idler gear next to thrust washer, with hub facing toward rear of case.

Before attempting installation of mainshaft assembly into case, slide third-fourth synchronizing sleeve forward into fourth speed position.

11. Lower mainshaft assembly into case making certain notches on fourth speed blocking ring correspond to keys in synchronizing assembly. See Figure 72-58.

12. With guide pin in rear bearing retainer aligned with hole in rear of case, tap rear bearing retainer into position with a soft hammer.

13. From rear of case, insert rear reverse idler gear, engaging splines with portion of front gear inside case.

14. Using heavy grease, place gasket in position on rear face of rear bearing retainer.

15. Install the remaining flat thrust washer on reverse idler shaft. If new idler shaft is being used, drive out the roll pin and press it into new shaft.

16. Install reverse idler shaft, roll pin, and thrust washer into gears and front boss of case. Make certain to pick up front tanged thrust washer. Roll pin should be in a vertical position.

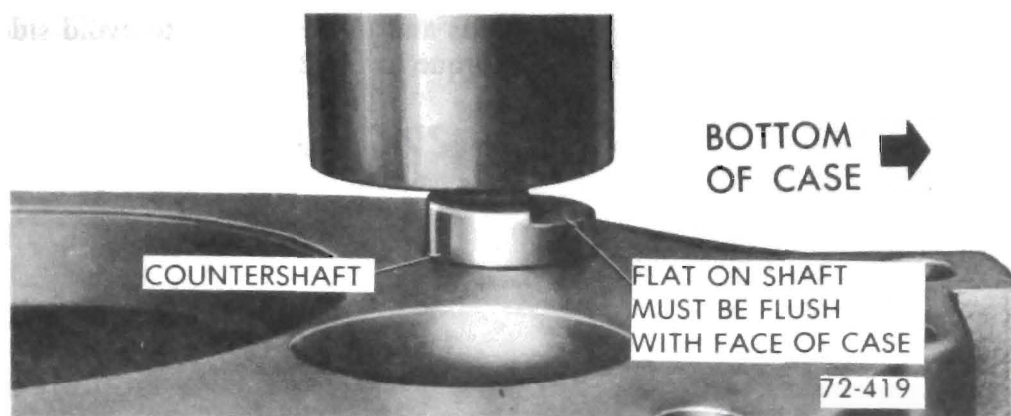

Figure 72-56 - Installing Countershaft

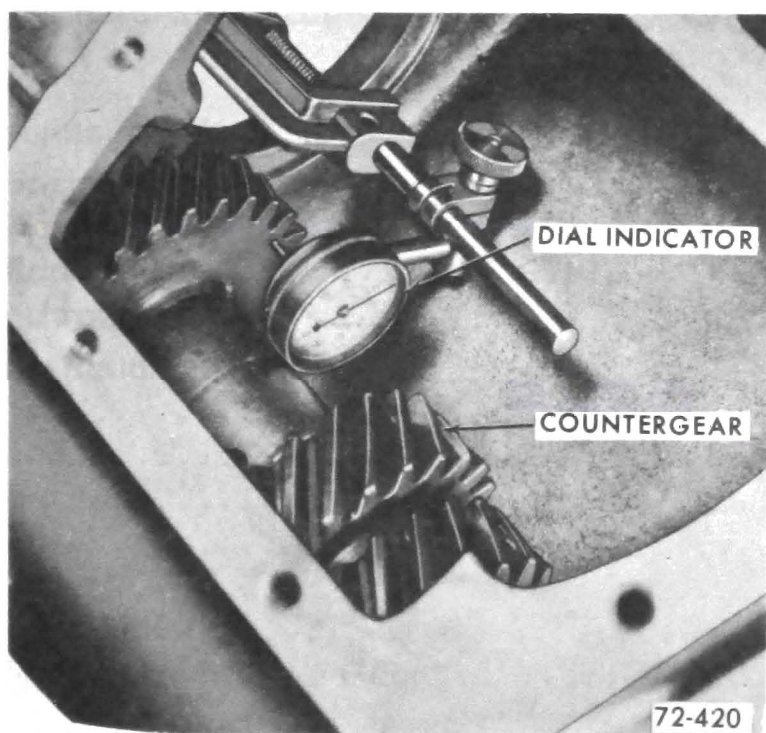

Figure 72-57 - Checking Countergear Alignment

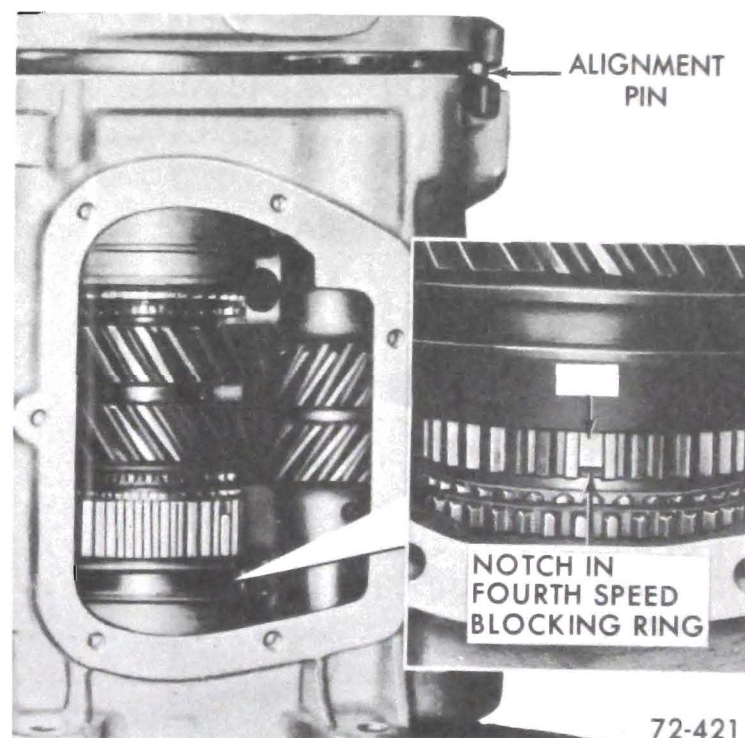

Figure 72-58 - Installing Mainshaft Assembly

17. Position reverse gear at rear of spline, pull reverse shifter shaft to left side of extension and rotate shaft to bring reverse shift fork forward in extension (reverse detent position). Start the extension onto transmission case, while slowly pushing in on shifter shaft to engage shift fork with reverse gear shift collar. Then pilot reverse idler gear shaft into extension housing permitting extension to slide onto transmission case.

18. Install six extension and retainer-to-case attaching bolts. Torque upper 3 bolts to 15-24 lb.ft.; lower 3 bolts to 25-35 lb.ft.

19. Push or pull reverse shifter shaft to line up groove in shaft with holes in the boss and drive in lock pin. Install shifter lever.

20. Press bearing onto main drive gear (snap ring groove to front) and into case until several main drive gear retaining nut threads are exposed.

21. Lock transmission up by shifting into two gears. Install main drive gear retaining nut on main drive gear shaft and draw up tight, using Tool J-933. Make certain bearing seats fully against shoulder on gear. Torque retaining nut to 40 lb.ft. and lock in place by staking securely into main drive gear shaft hole with a center punch. Care must be used to avoid damaging threads on shaft.

22. Install main drive gear bearing retainer, gasket and four attaching bolts with locking strips, using a suitable sealer on bolts. The retainer oil return hole must be positioned toward bottom of transmission case. Torque to 18-24 lb.ft.

23. Shift third-fourth sliding sleeve into neutral position and first-second sliding sleeve into second gear (forward) position. Shift side cover third fourth shifter lever into neutral detent and first-second shifter lever into second gear detent position.

24. Install side cover gasket and carefully position side

cover into place. There is a dowel pin in cover to assure proper alignment with case. Install attaching

bolts and tighten evenly to avoid side cover distortion. Torque to 14-22 lb.ft.

DIVISION VI SPECIFICATIONS

72-24 GENERAL SPECIFICATIONS

a. Transmission Identification

A production code number and Car Serial Number are stamped on all G.S. and G.S. Stage 1 four-speed manual transmissions. These numbers should always be furnished on all AFA Forms, and all correspondence with the factory concerning a particular transmission.

b. General Specifications

Type	All Forward Gears Synchronized
Mounting	Unit with Engine
Lubricant	
Type	SAE 80 or 90 Multi-Purpose
Capacity	3 Pints
Synchronization	1st, 2nd, 3rd and 4th
Gear Ratios	
1st	2.20 to 1
2nd	1.64 to 1
3rd	1.28 to 1
4th	1.00 to 1
Reverse	2.27 to 1
Gear Shifting	On Floor
Speedometer Drive Gear	Nylon

c. Bolt Tightening Specifications

Location	Thread Size	Torque Lbs. Ft.
Front Main Bearing Retainer	3/8 - 16 x 7/8	18 - 24
Side Cover to Case	3/8 - 16 x 7/8	14 - 22
Case Extension Top Three	3/8 - 16 x 1 3/4	15 - 24
Case Extension Bottom Three	7/16 - 14 x 2 1/2	25 - 35
Lubrication Filler Plug		25 - 35
Transmission Case to Flywheel Housing		45 - 60

Use a reliable wrench to tighten the parts listed to insure proper tightness without straining or distorting parts. These specifications are for **clean and lightly lubricated threads only**; dry or dirty threads produce increased friction which prevents accurate measurement of tightness.

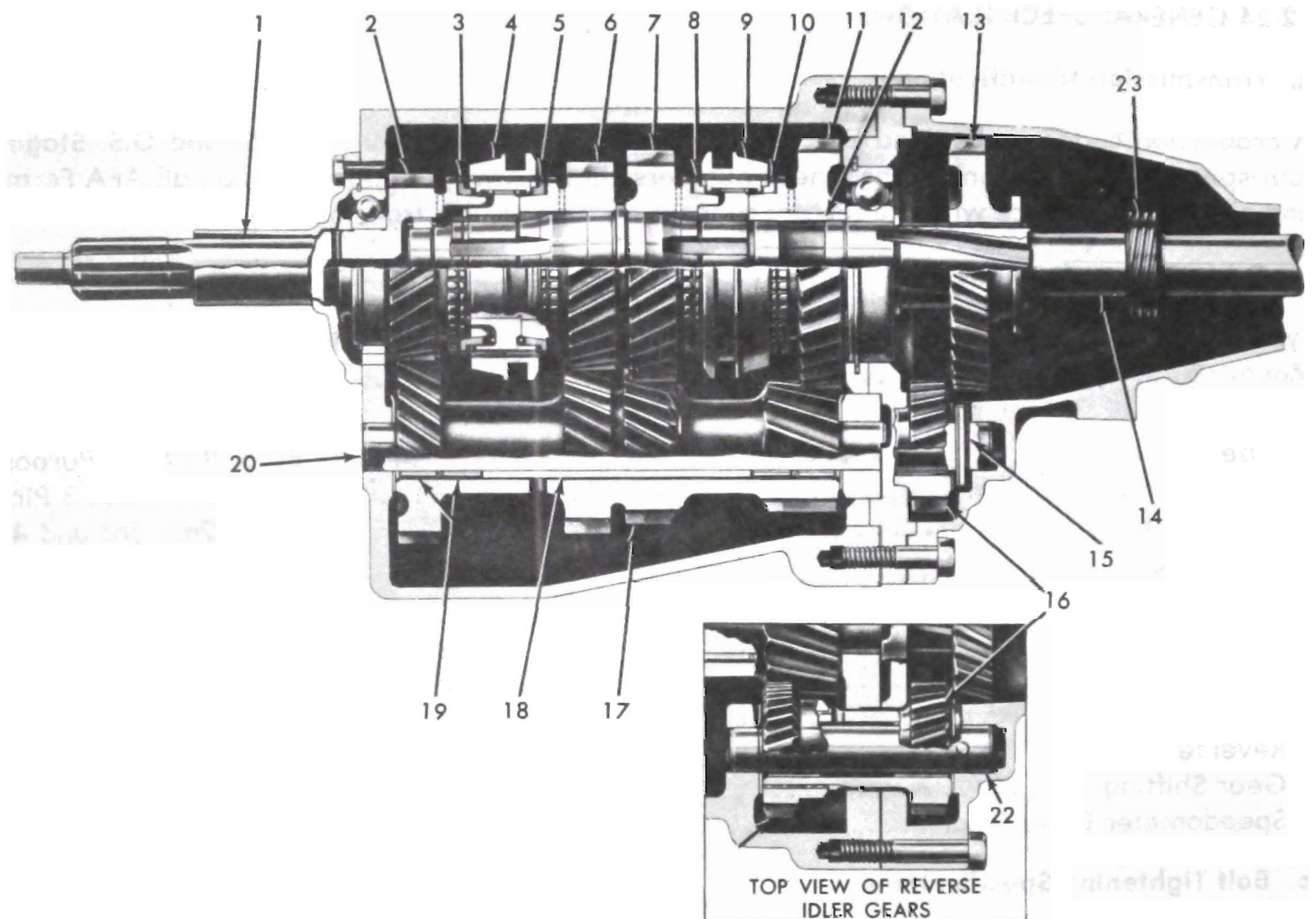

FOUR—SPEED TRANSMISSION CROSS SECTION

- | | | |
|--|--|--|
| 1. BEARING RETAINER | 9. FIRST AND SECOND SPEED SYNCHRONIZING ASSEMBLY | 17. COUNTERGEAR |
| 2. MAIN DRIVE GEAR | 10. FIRST SPEED BLOCKING RING | 18. COUNTERSHAFT BEARING ROLLER SPACE |
| 3. FOURTH SPEED BLOCKING RING | 11. FIRST SPEED GEAR | 19. COUNTERSHAFT NEEDLE ROLLER BEARING |
| 4. THIRD AND FOURTH SPEED SYNCHRONIZING ASSEMBLY | 12. FIRST SPEED GEAR SLEEVE | 20. COUNTERSHAFT |
| 5. THIRD SPEED BLOCKING RING | 13. REVERSE GEAR | 21. REVERSE IDLER GEAR (FRONT) |
| 6. THIRD SPEED GEAR | 14. MAIN SHAFT | 22. REVERSE IDLER SHAFT |
| 7. SECOND SPEED GEAR | 15. REVERSE IDLER SHAFT ROLL PIN | 23. SPEEDO DRIVE GEAR |
| 8. SECOND SPEED BLOCKING RING | 16. REVERSE IDLER GEAR (REAR) | |

Figure 72-59 Cross Section of 4-Speed Manual Transmission

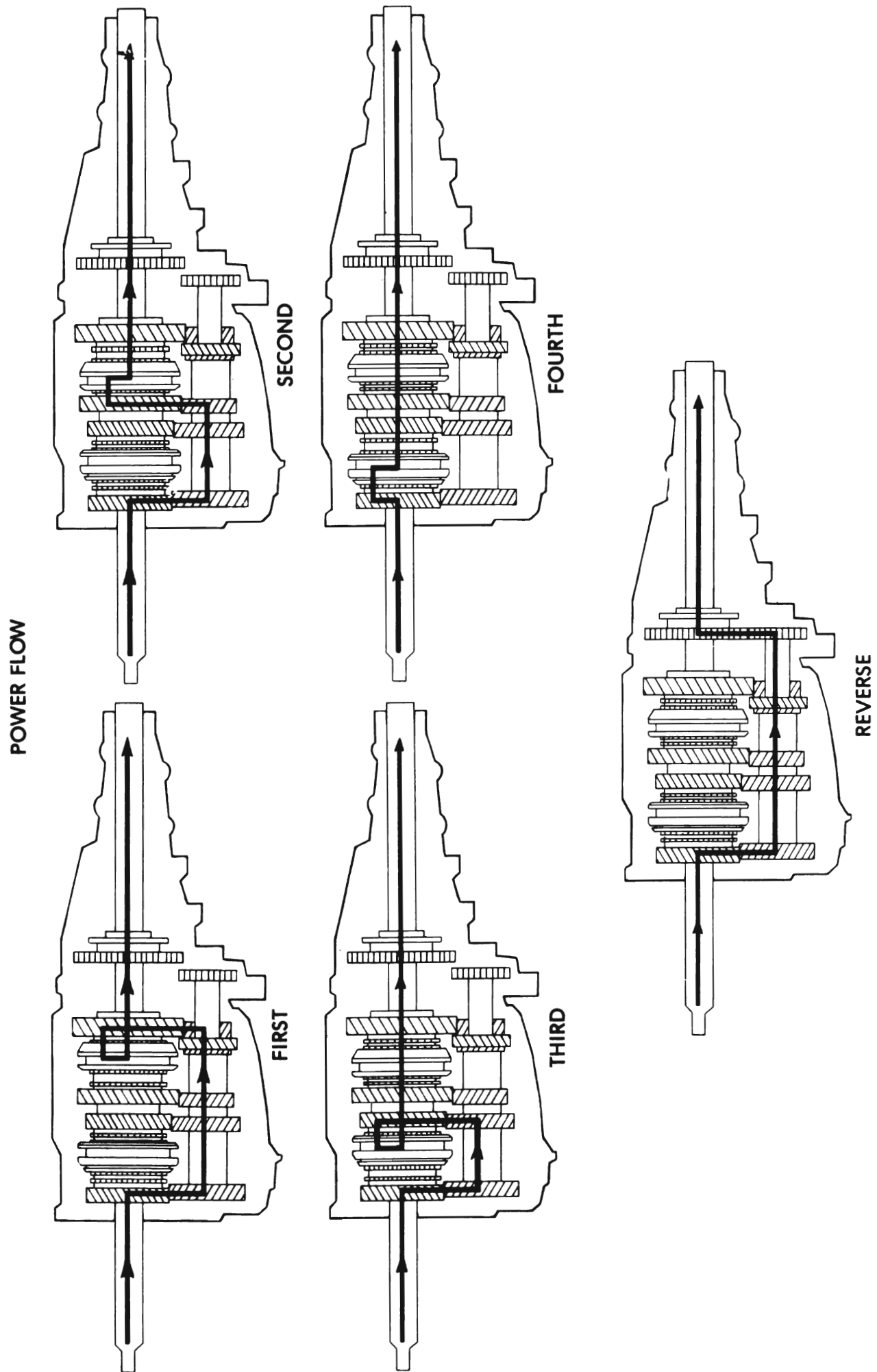
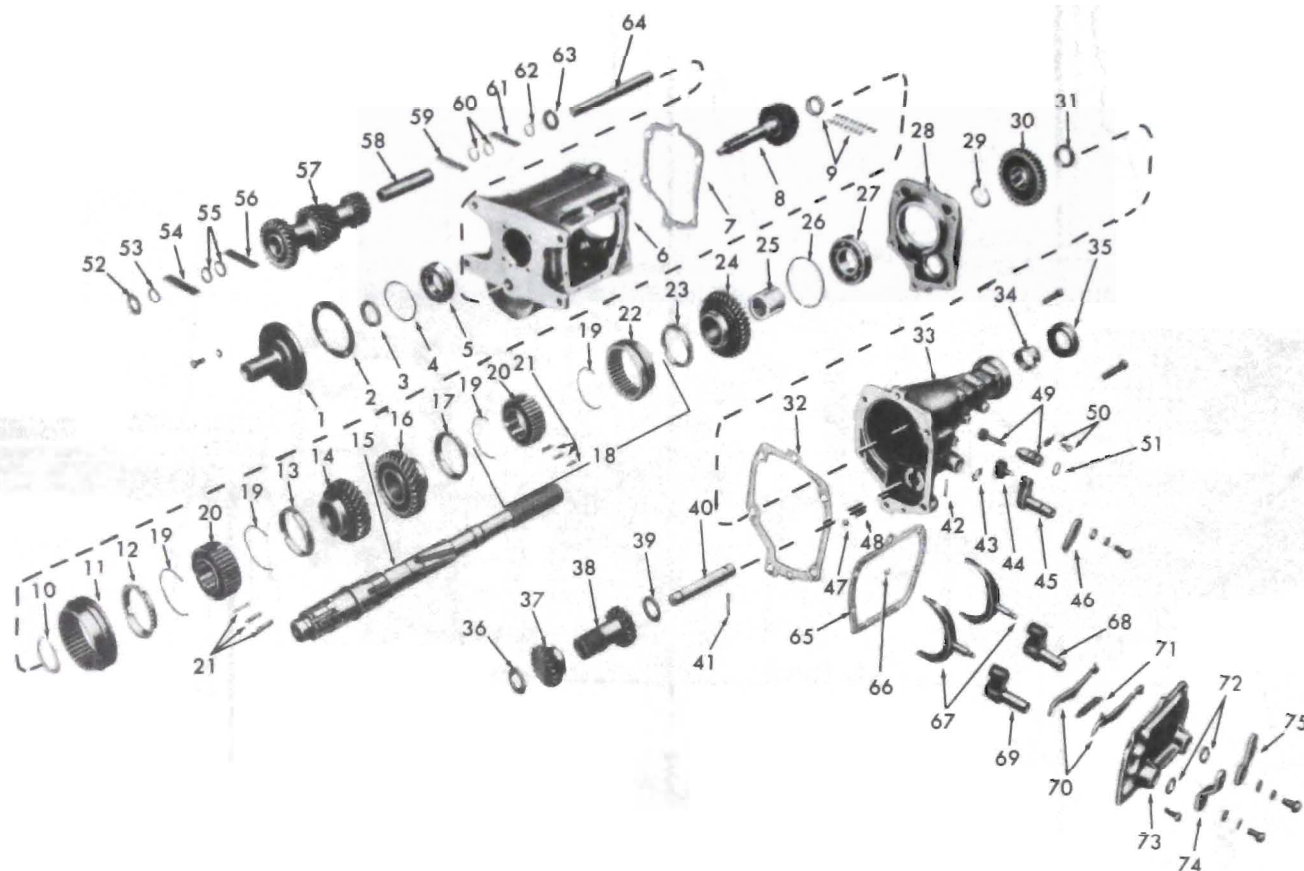

Figure 72-60 Power Flow



Four-Speed Transmission-Exploded View

- | | | | |
|--|---|---|---|
| 1. Bearing Retainer | 19. Clutch Key Spring | 40. Reverse Idler Shaft | 58. Countergear Roller Spacer |
| 2. Gasket | 20. Clutch Hub | 41. Reverse Idler Shaft
Roll Pin | 59. Bearing Rollers (28) |
| 3. Bearing Retaining Nut | 21. Clutch Keys | 42. Reverse Shifter Shaft
Lock Pin | 60. Spacer |
| 4. Bearing Snap Ring | 22. First and Second Speed
Sliding Sleeve | 43. Reverse Shifter Shaft
Lip Seal | 61. Bearing Rollers (28) |
| 5. Front Main Bearing | 23. First Speed Gear
Blocking Ring | 44. Reverse Shift Fork | 62. Spacer |
| 6. Transmission Case | 24. First Speed Gear | 45. Reverse Shifter Shaft
and Detent Plate | 63. Tanged Washer |
| 7. Rear Bearing
Retainer Gasket | 25. First Gear Sleeve | 46. Reverse Shifter Lever | 64. Countershaft |
| 8. Main Drive Gear | 26. Rear Bearing Snap Ring | 47. Reverse Shifter Shaft
Detent Ball | 65. Gasket |
| 9. Bearing Rollers (17)
and Cage | 27. Rear Bearing | 48. Reverse Shifter Shaft
Ball Detent Spring | 66. Detent Cams Retainer Ring |
| 10. Snap Ring | 28. Rear Bearing Retainer | 49. Speedometer Driven
Gear and Fitting | 67. Forward Speed Shift Forks |
| 11. Third and Fourth Speed
Sliding Sleeve | 29. Selective Fit Snap Ring | 50. Retainer and Bolt | 68. First - Second Speed Gear
Shifter Shaft and Detent Plate |
| 12. Fourth Speed Gear
Blocking Ring | 30. Reverse Gear | 51. "O" Ring Seal | 69. Third - Fourth Speed Gear
Shifter Shaft and Detent Plate |
| 13. Third Speed Blocking
Ring | 31. Speedometer Drive Gear | 52. Tanged Washer | 70. Detent Cams |
| 14. Third Speed Gear | 32. Rear Bearing Retainer to
Case Extension - Gasket | 53. Spacer | 71. Detent Cam Spring |
| 15. Main Shaft | 33. Case Extension | 54. Bearing Rollers (28) | 72. "O" Ring Seals |
| 16. Second Speed Gear | 34. Extension Bushing | 55. Spacer | 73. Transmission Side Cover |
| 17. Second Speed Gear
Blocking Ring | 35. Rear Oil Seal | 56. Bearing Rollers (28) | 74. Third - Fourth Speed
Shifter Lever |
| 18. First and Second Speed
Synchronizing Assembly | 36. Reverse Idler Front Thrust
Washer (Tanged) | 57. Countergear | 75. First - Second Speed
Shifter Lever |
| | 37. Reverse Idler Gear (Front) | | |
| | 38. Reverse Idler Gear (Rear) | | |
| | 39. Flat Thrust Washer | | |

Figure 72-61 Exploded View of Transmission

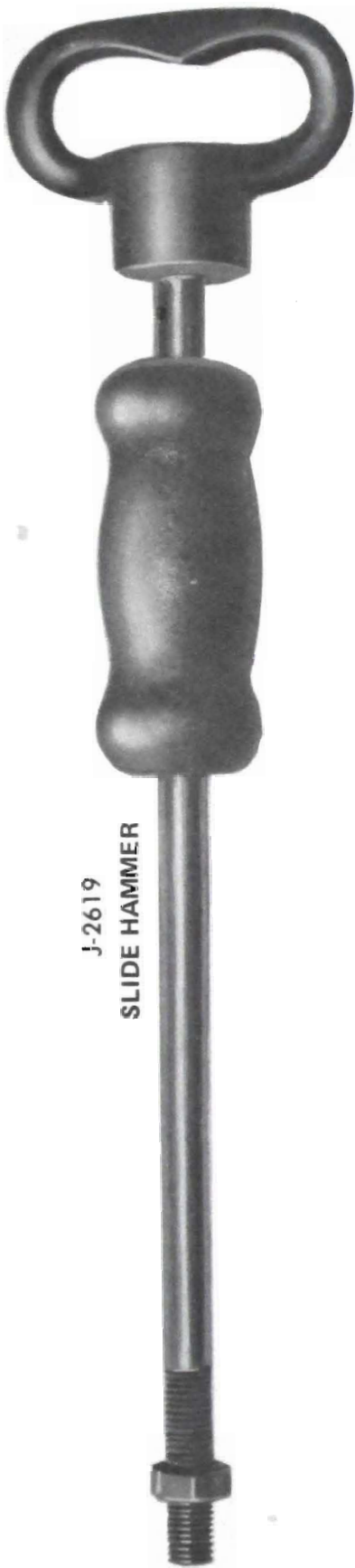

J-2619
SLIDE HAMMER



SNAP RING PLIERS

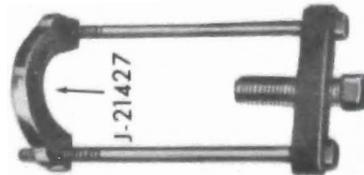

J-21427

J-9578

SPEEDO-GEAR
REMOVER

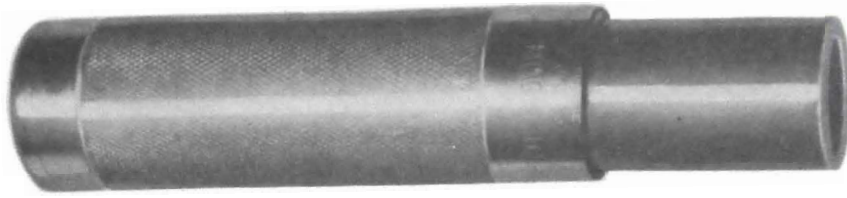

OIL SEAL
INSTALLER

J-6403-2



J-6403-1

BUSHING INSTALLER

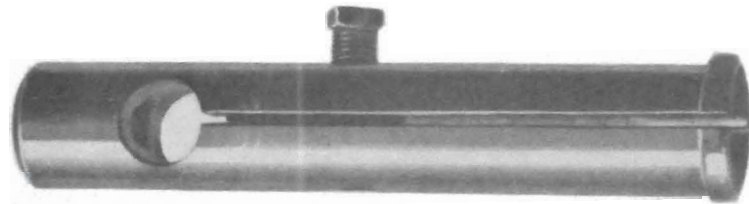

J-4830-02

BUSHING AND OIL
SEAL REMOVER

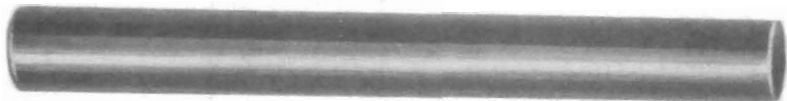

J-22246

COUNTERSHAFT GEAR
ALIGNMENT TOOL

Figure 72-62 Tool Picture