

SECTION A**CLUTCH****4D-4F-4G-4H SERIES****CONTENTS**

| Division | Subject | Page No. |
|-----------------|---|---|
| I | TROUBLE DIAGNOSIS: Clutch Trouble Diagnosis | 71-2 |
| II | DESCRIPTION AND OPERATION: Description and Operation | 71-4 |
| III | ADJUSTMENTS AND MINOR SERVICE: Clutch Lash Adjustment | 71-4 |
| IV | REMOVAL AND INSTALLATION: Removal of Clutch Lubrication and Inspection of Clutch Installation of Clutch | 71-5 71-5 71-6 |
| V | OVERHAUL AND MAJOR SERVICE: (Not Applicable) | |
| VI | SPECIFICATIONS: Specifications | 71-7 |

DIVISION I**TROUBLE DIAGNOSIS****71-1 CLUTCH TROUBLE DIAGNOSIS**

| Condition | Possible Cause | Correction |
|--|---------------------------------|---|
| Fails to Release (pedal pressed to floor - shift lever does not move freely in and out of "Reverse" gear). | 1. Improper linkage adjustment. | 1. Adjust linkage. |
| | 2. Improper pedal travel. | 2. Trim bumper stop and adjust linkage. |

| | | |
|-------------------------------|---|---|
| | 3. Loose linkage. | 3. Replace bushings. |
| | 4. Faulty pilot bearing. | 4. Replace bearing. |
| | 5. Faulty driven plate. | 5. Replace driven plate. |
| | 6. Fork off ball stud. | 6. Install properly. |
| | 7. Clutch driven plate hub binding on main drive gear spline. | 7. Repair or replace main drive. |
| Slipping | 1. Improper adjustment (no lash). | 1. Adjust linkage. |
| | 2. Oil soaked driven plate. | 2. Install new driven plate and correct oil leak at its source. |
| | 3. Worn facing or facing torn from driven plate. | 3. Replace driven plate. |
| | 4. Warped pressure plate or flywheel. | 4. Replace same. |
| | 5. Weak diaphragm spring. | 5. Replace cover assembly. |
| | 6. Driven plate not seated in. | 6. Make 20-50 normal starts. |
| | 7. Driven plate overheated. | 7. Allow to cool - check lash. |
| Grabbing | 1. Oil on facing or burned or glazed facings. | 1. Install new driven plate. |
| | 2. Worn splines on main drive gear. | 2. Replace transmission main drive gear. |
| | 3. Loose engine mountings. | 3. Tighten or replace mountings. |
| | 4. Warped pressure plate or flywheel. | 4. Replace pressure plate or flywheel. |
| | 5. Burned or smeared resin on flywheel or pressure plate. | 5. Sand off if superficial. Replace burned or heat checked parts. |
| Rattling - Transmission Click | 1. Clutch fork loose on ball stud or in bearing groove. | 1. Check ball stud and retaining spring and replace if necessary. |
| | 2. Oil in driven plate damper. | 2. Replace driven plate. |
| | 3. Driven plate damper spring failure. | 3. Replace driven plate. |

71-4 1972 BUICK SERVICE MANUAL

Throw-Out Bearing Noise
With Clutch Fully
Engaged

1. Improper adjustment.

1. Adjust linkage.

2. Throw-out bearing binding
on transmission bearing
retainer.

2. Clean, relubricate, check for
burrs, nicks, etc.

3. Insufficient tension
between clutch fork
spring and ball stud.

3. Replace fork.

4. Fork improperly
installed.

4. Install properly.

5. Weak linkage return spring.

5. Replace spring.

Noisy

1. Worn throw-out bearing.

1. Replace bearing.

2. Fork off ball stud
(heavy clicking).

2. Install properly.

Pedal Stays on Floor When
Disengaged

1. Bind in linkage.

1. Lubricate and free-up linkage.

2. Spring weak in pressure
plate.

2. Replace

3. Weak linkage return
spring.

3. Replace

High Pedal Effort

1. Bind in linkage.

1. Lubricate and free-up linkage.

2. Driven plate worn.

2. Replace driven plate.

DIVISION II**DESCRIPTION AND OPERATION****71-2 DESCRIPTION AND OPERATION**

A single plate, dry disc clutch is used on all manual transmission equipped Skylark, Skylark Custom, G.S. and Sportwagon models.

The pressure plate for the 350 cu. in. engine continues to use a straight finger type belleville spring for clutch release while the pressure plate for the 455 cubic inch engine, as used in the G.S., utilizes a bent finger-type belleville spring. See Figure 71- 3.

DIVISION III**ADJUSTMENTS AND MINOR SERVICE****71-3 CLUTCH LASH ADJUSTMENT**

Pedal lash, free pedal, must be adjusted occasionally to compensate for normal wear of the clutch facing. As the driven plate wears thinner, pedal lash decreases.

To adjust pedal lash:

1. Make certain clutch fork is on ball stud. See Figure 71-4.

2. Unhook return spring from clutch fork.

3. Push and hold equalizer and release rod toward front of car while at the same time holding the clutch fork toward the rear of the car.

4. If clutch is properly adjusted, there will be 1/16" to 1/8" clearance between the end of the rod and the clutch fork. Lash at the pedal should be 5/8" to 7/8".

DIVISION IV

REMOVAL AND INSTALLATION

71-4 REMOVAL OF CLUTCH

A. Removal from Vehicle

1. Remove transmission.
2. Remove pedal return spring from clutch fork. See Figure 72-4.
 - a. On G. S. models, disconnect rod assembly from clutch fork. See Figure 71-5.
3. Remove flywheel housing.
4. Remove clutch throw-out bearing from clutch fork.
5. Disconnect clutch fork from ball stud by moving it toward the center of flywheel housing.
6. Mark clutch cover and flywheel so that cover can be reinstalled in the same position on flywheel to preserve engine balance.
7. Loosen clutch cover to flywheel attaching bolts one turn at a time each to avoid bending of clutch cover flange until spring pressure is released.
8. Support the pressure plate and cover assembly while removing last bolts, then remove pressure plate and clutch driven plate assemblies. Use extreme care in keeping clutch driven plate clean.
9. Should it be necessary to disassemble the pressure plate, proceed as follows:

- a. Remove three drive-strap to pressure plate bolts and retracting spring. Then lift off clutch cover.

Alignment marks should be made on clutch cover and pressure plate for assembly purposes to maintain balance.

- b. The clutch Belleville spring and two pivot rings are riveted to the clutch cover. The spring, rings and cover should be inspected for wear or damage. If necessary, replace the complete cover assembly.

71-5 LUBRICATION AND INSPECTION OF CLUTCH

A. Inspection of Clutch

Wash all metal parts of clutch, except release bearing and driven plate in suitable cleaning solution to remove dirt and grease. Soaking release bearing in cleaning solution would permit solution to seep into

bearing and destroy the lubricant. Soaking driven plate in cleaning solution would damage the facings.

1. *Flywheel and Pressure Plate.* Examine friction surfaces of flywheel and pressure plate for scoring or roughness. Slight roughness may be smoothed with fine emery cloth, but if surface is deeply scored or grooved the part should be replaced.

2. *Clutch Driven Plate.* Inspect driven plate for condition of facings, loose rivets, broken or very loose torsional springs, and flattened cushion springs.

If facings are worn down near rivets or are oily, the plate assembly should be replaced. A very slight amount of oil on clutch facings will cause clutch grab and chatter. A large amount of oil on facings will cause slippage. Removal of oil by solvents or by buffing is not practical since oil will continue to bleed from facing material when hot.

When oil is found on driven plate facings, examine transmission drainback hole, pilot bushing, engine rear main bearing and other points of oil leakage.

Test the fit of driven plate hub on transmission main drive gear for any easy sliding fit.

Regardless of whether the old plate or a new one is to be installed, the plate should be checked for run-out. This check can be made by following steps outlined in Figures 71-1 and 71-2.

3. *Bearings* Inspect clutch throw-out bearing for scoring or excessive wear on front contact face. Test for roughness of balls and races by pressing and turning front race slowly. Inspect main drive gear pilot

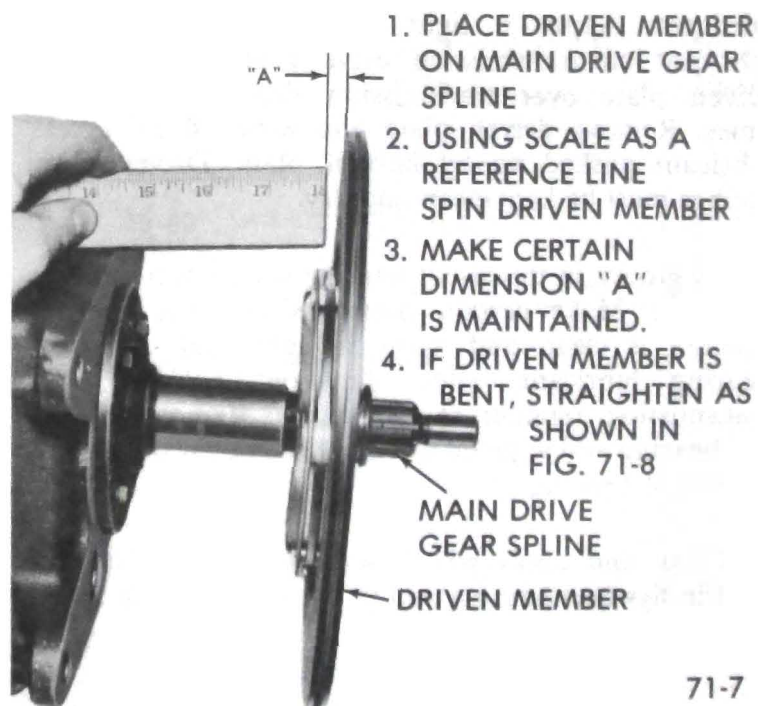

Figure 71-1 - Checking Driven Plate Run-Out

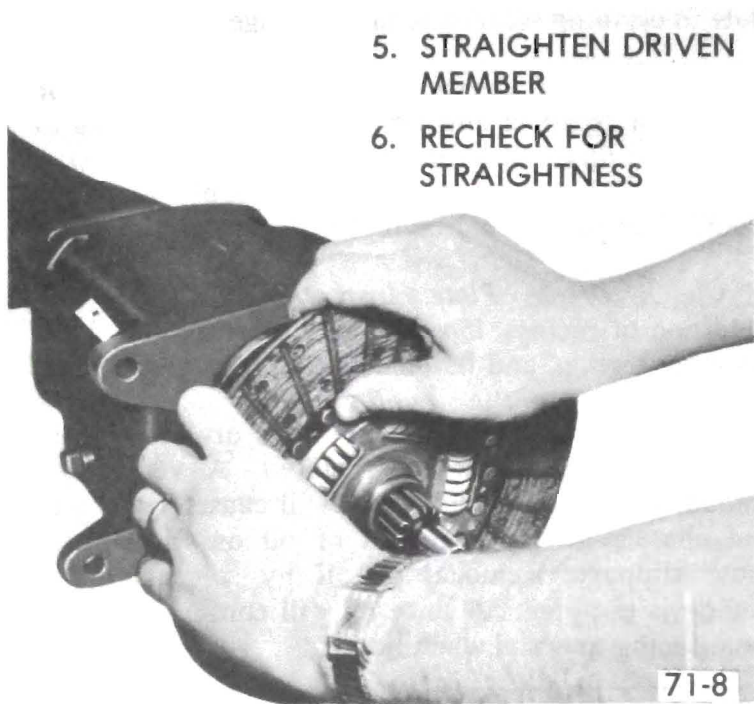

Figure 71-2 - Checking Driven Plate Run-Out

bushing in crankshaft. If bushing is rough or worn it should be replaced.

B. Lubrication of Clutch

1. Very sparingly apply wheel bearing lubricant in pilot bushing in crankshaft. If too much lubricant is used, it will run out on face of flywheel when hot and ruin the driven plate facings.

2. Make sure that splines in the driven plate hub are clean and apply a light coat of wheel bearing lubricant. Apply a light coat of wheel bearing lubricant on transmission drive gear splines. Slide driven plate over transmission drive gear several times. Remove driven plate and wipe off all excess lubricant pushed up by hub of plate. Driven plate facings must be kept clean and dry.

3. Fill groove in throw-out bearing with wheel bearing lubricant. Make certain transmission front bearing retainer is clean and apply a light coat of wheel bearing lubricant. Slide throw-out bearing over transmission retainer several times. Remove throw-out bearing and wipe off all excess lubricant pushed up by hub of bearing.

4. Clean and apply wheel bearing lubricant to ball stud in flywheel housing and to the seat in clutch fork.

5. Check clutch pilot bearing for excessive wear or damage. If replacement is necessary, remove bearing with Puller J-1448. For installation use Driver J-1522.

Very sparingly apply wheel bearing lubricant in pilot bushing. If too much lubricant is used, it will run out on face of flywheel when hot and ruin the driven plate facings.

71-6 INSTALLATION OF CLUTCH

A. Installation of Clutch (Refer to Figures 71-3, 71-4, 71-5, 71-6, and 71-7)

1. If the pressure plate was disassembled, follow steps a and b.

a. Install the pressure plate in the cover assembly, lining up the groove on the edge of the pressure plate with the groove on the edge of the cover.

b. Install pressure plate retracting springs and drive-strap to pressure plate bolts and lock washers and tighten to 16 lb.ft. torque. The clutch is now ready to be installed.

2. Install the pressure plate and driven plate. Support both assemblies with a spare main drive gear. Be sure to align marks on clutch cover with the mark made on the flywheel at disassembly.

3. Install all bolts so that clutch is drawn in place square with flywheel. Each bolt must be drawn one turn at a time to avoid bending the clutch cover flange. Torque bolts to 30-40 lb.ft.

4. Lubricate the ball stud and clutch fork with wheel bearing lubricant and install clutch fork.

Check and insure that fork retaining spring is tight on pivot ball stud.

5. Lubricate the recess on the inside of the throw-out bearing collar. Be careful not to use too much lubricant.

6. Install throw-out bearing assembly.

7. Install flywheel housing. Insure that dowel pins are in place in crankcase. Make certain throw-out bearing is seated in clutch fork.

8. Install transmission.

9. Connect and adjust clutch linkage. See paragraph 71-3.

DIVISION VI**SPECIFICATIONS****71-7 GENERAL SPECIFICATIONS****A. Clutch Specifications**

| | 350 Cu.In. | | 455 Cu.In. |
|-------------------------|---------------------|-------------------------|---------------------|
| Type | | Single Plate - Dry Disc | |
| Pedal Pressure | | 28 to 35 Lbs. (New) | |
| Pedal Lash | 5/8"-7/8" | | 5/8"-7/8" |
| Driven Plate Diameter | 10.4" | | 11" |
| Driven Plate Facings | | Woven Asbestos | |
| Number of Facings | | 2 | |
| Facing Attachment | | Riveted | |
| Facing Area (Sq.In.) | 103.5 | | 123.7 |
| Vibration Dampening | 6 Torsional Springs | | 5 Torsional Springs |

B. Bolt Tightening Specifications

| Location | Skylark, Skylark Custom and and Sportwagon | | G.S. Series | |
|---|---|-------------------|----------------|-------------------|
| | Thread Size | Torque Lbs.Ft. | Thread Size | Torque Lbs.Ft. |
| Clutch Cover to Flywheel | 3/8-16 x 1 | 30-40 | 3/8-16 x 1 | 30-40 |
| Clutch Release Fork Ball | 13/16-16 | 35-45 | 13/16-16 | 35-45 |
| Flywheel Housing to Cylinder Block | 3/8-16 x 1-1/4 | 45-60 | 3/8-16 x 1-1/4 | 45-60 |
| Clutch Equalizer Ball Stud: | | | | |
| To Engine | 1/2-13 | 30-40 | 1/2-13 | 30-40 |
| To Frame Bracket | 3/8-16 | 20-30 | 3/8-16 | 20-30 |
| To Trans. Bracket | - | - | - | - |
| Clutch Equalizer Bracket | | | | |
| To Trans. | - | - | - | - |
| Trans. to Flywheel Housing | 7/16-14 | 45-60 | 7/16-14 | 45-60 |
| Clutch Equalizer Bracket | | | | |
| To Frame | - | - | - | - |
| Clutch Adjustment Lock Nut | 3/8-16 | 5-15 | 3/8-16 | 5-15 |

5. To increase caster and camber at the same time -
remove an amount of shims *at front bolt only*.

6. To decrease caster and camber at the same time -
add an amount of shims *at front bolt only*.

INSERT ALL BOLTS SO THAT CLUTCH IS DRAWN IN PLACE SQUARE WITH FLYWHEEL EACH BOLT SHOULD BE DRAWN ONE OR TWO TURNS AT A TIME TO AVOID BENDING THE FLANGE OF THE CLUTCH. IN REMOVING THE CLUTCH THE SAME METHOD SHOULD BE USED

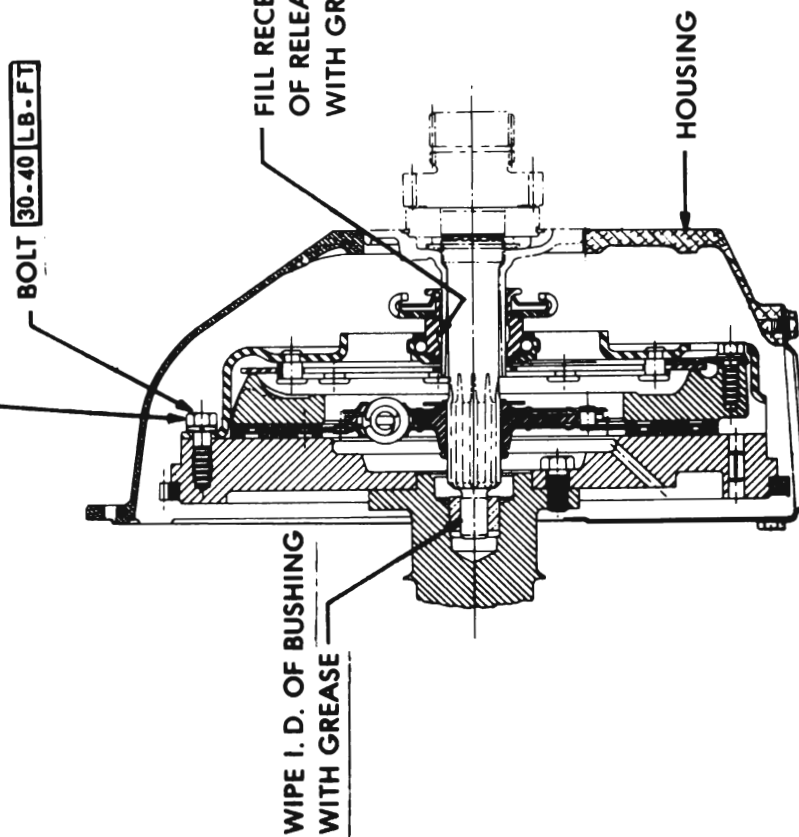

SKYLARK, SKYLARK CUSTOM AND SPORTWAGON (350 CU. IN. ENGINE)

INSERT ALL BOLTS SO THAT CLUTCH IS DRAWN IN PLACE SQUARE WITH FLYWHEEL EACH BOLT SHOULD BE DRAWN ONE OR TWO TURNS AT A TIME TO AVOID BENDING THE FLANGE OF THE CLUTCH. IN REMOVING THE CLUTCH THE SAME METHOD SHOULD BE USED.

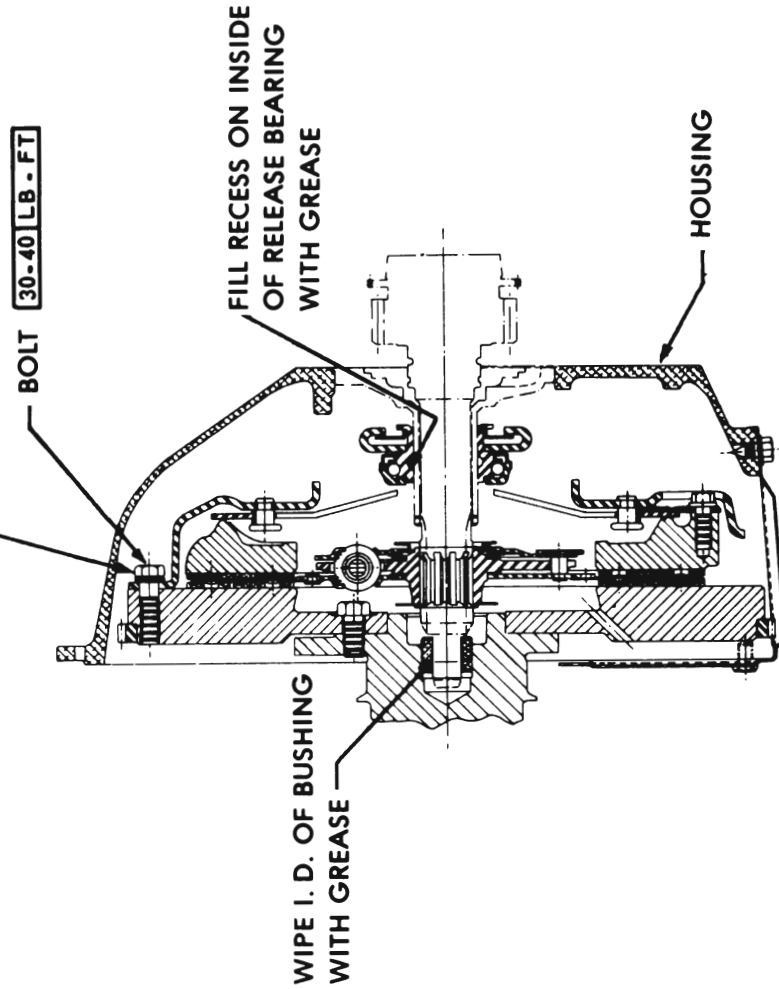

G.S. AND SPORTWAGON

Figure 71-3 Clutch Assemblies (350 and 455 Engines)

CLUTCH LASH ADJUSTMENT

350 CU IN
WITH CLUTCH PEDAL AT FULL RELEASE POSITION, CONTACTING THE RUBBER BUMPER STOP, ADJUST THE CLUTCH RELEASE ROD TO GIVE ZERO LASH AT CLUTCH PEDAL. (CLEVIS PIN WILL ASSEMBLE FREELY THROUGH CLUTCH FORK AND RELEASE ROD) REMOVE PIN AND BACK OFF THE RELEASE ROD APPROX 2 TURNS. WITH PIN AGAIN INSTALLED THE LASH AT THE PEDAL LOCKNUT ON CLUTCH RELEASE ROD. TIGHTEN LOCKNUT ON CLUTCH RELEASE ROD.

455 CU IN
WITH CLUTCH PEDAL AT FULL RELEASE POSITION, CONTACTING THE RUBBER BUMPER STOP, ADJUST THE CLUTCH RELEASE ROD TO GIVE ZERO LASH AT CLUTCH PEDAL.

BACK OFF CLUTCH RELEASE ROD APPROX 2 TURNS TO GIVE .61-.76 LASH AT PEDAL PAD. TIGHTEN LOCKNUT ON CLUTCH RELEASE ROD. TIGHTEN LOCKNUT ON CLUTCH RELEASE ROD. TIGHTEN LOCKNUT ON CLUTCH RELEASE ROD.

455 CU IN
WITH CLUTCH PEDAL AT FULL RELEASE POSITION, CONTACTING THE RUBBER BUMPER STOP, ADJUST THE CLUTCH RELEASE ROD TO GIVE ZERO LASH AT CLUTCH PEDAL.

BACK OFF CLUTCH RELEASE ROD APPROX 2 TURNS TO GIVE .61-.76 LASH AT PEDAL PAD. TIGHTEN LOCKNUT ON CLUTCH RELEASE ROD. TIGHTEN LOCKNUT ON CLUTCH RELEASE ROD. TIGHTEN LOCKNUT ON CLUTCH RELEASE ROD.

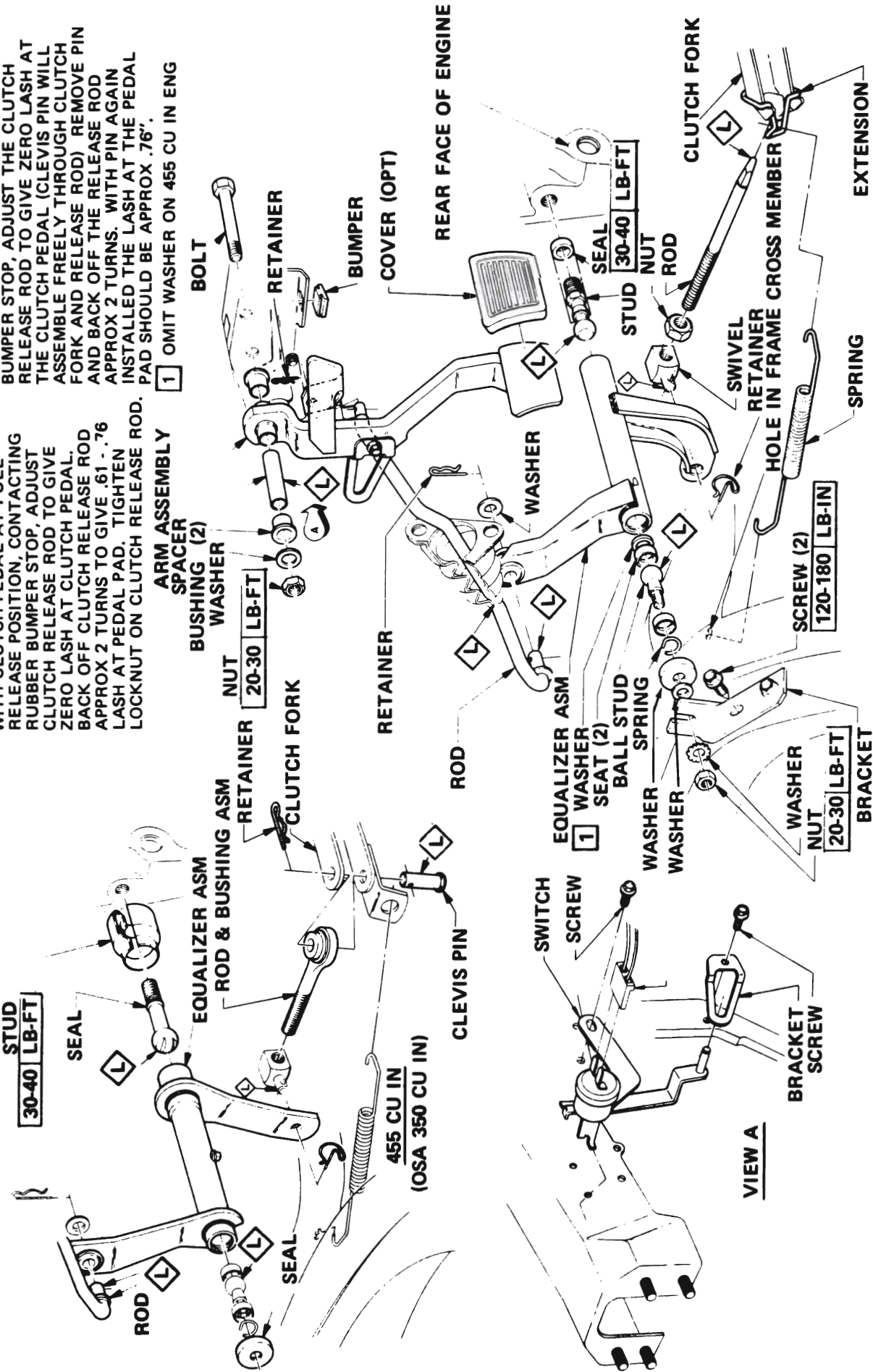

LUBRICATE AREAS INDICATED BEFORE ASSEMBLY. ◊ L

Figure 71-4 Clutch Controls - 4D-4F-4G-4H Series

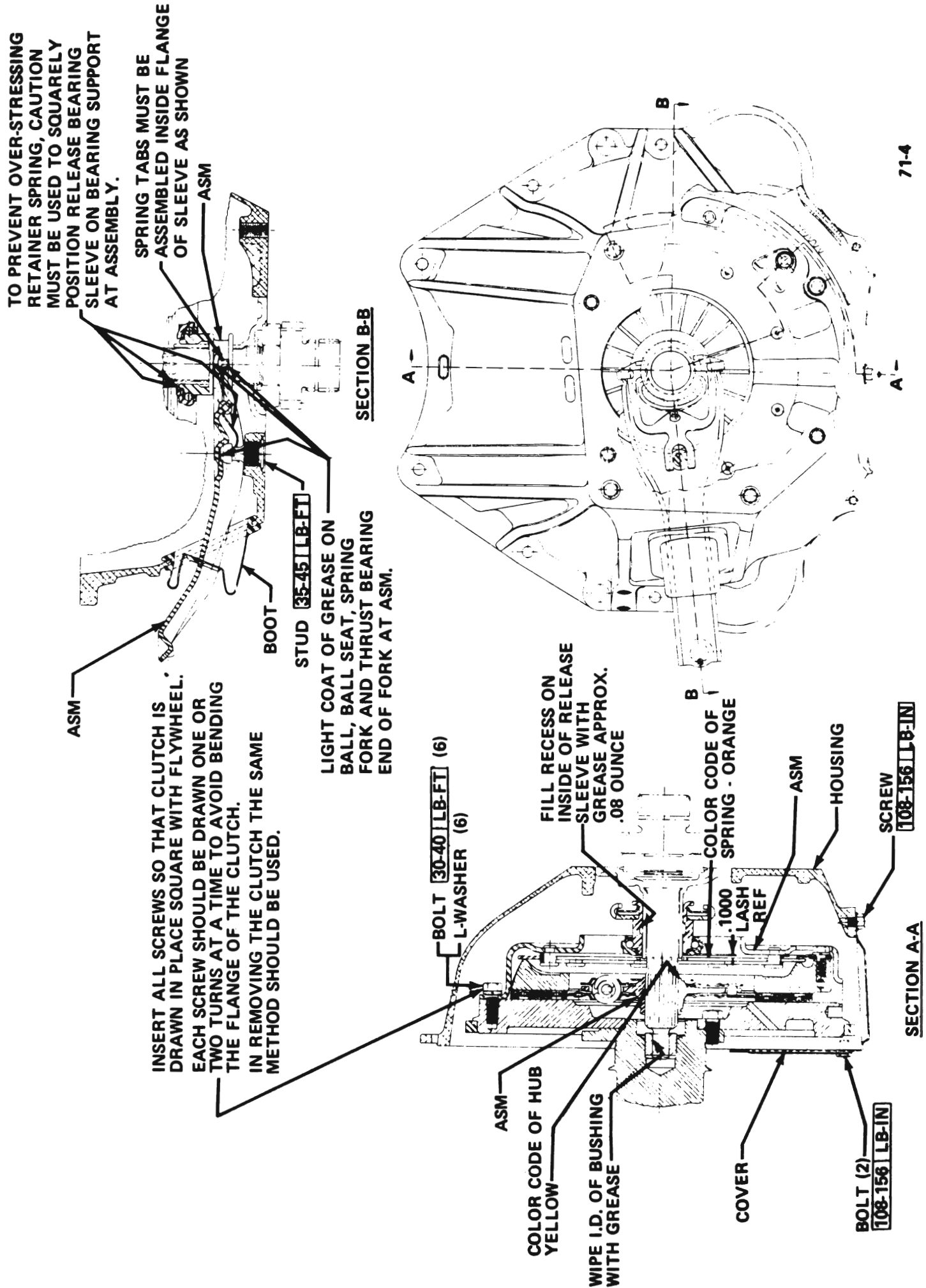

Figure 71-5 Clutch Inner Controls - 4D-4F-4G-4H Series (350 Cu.In. Engine) Less G.S. Series

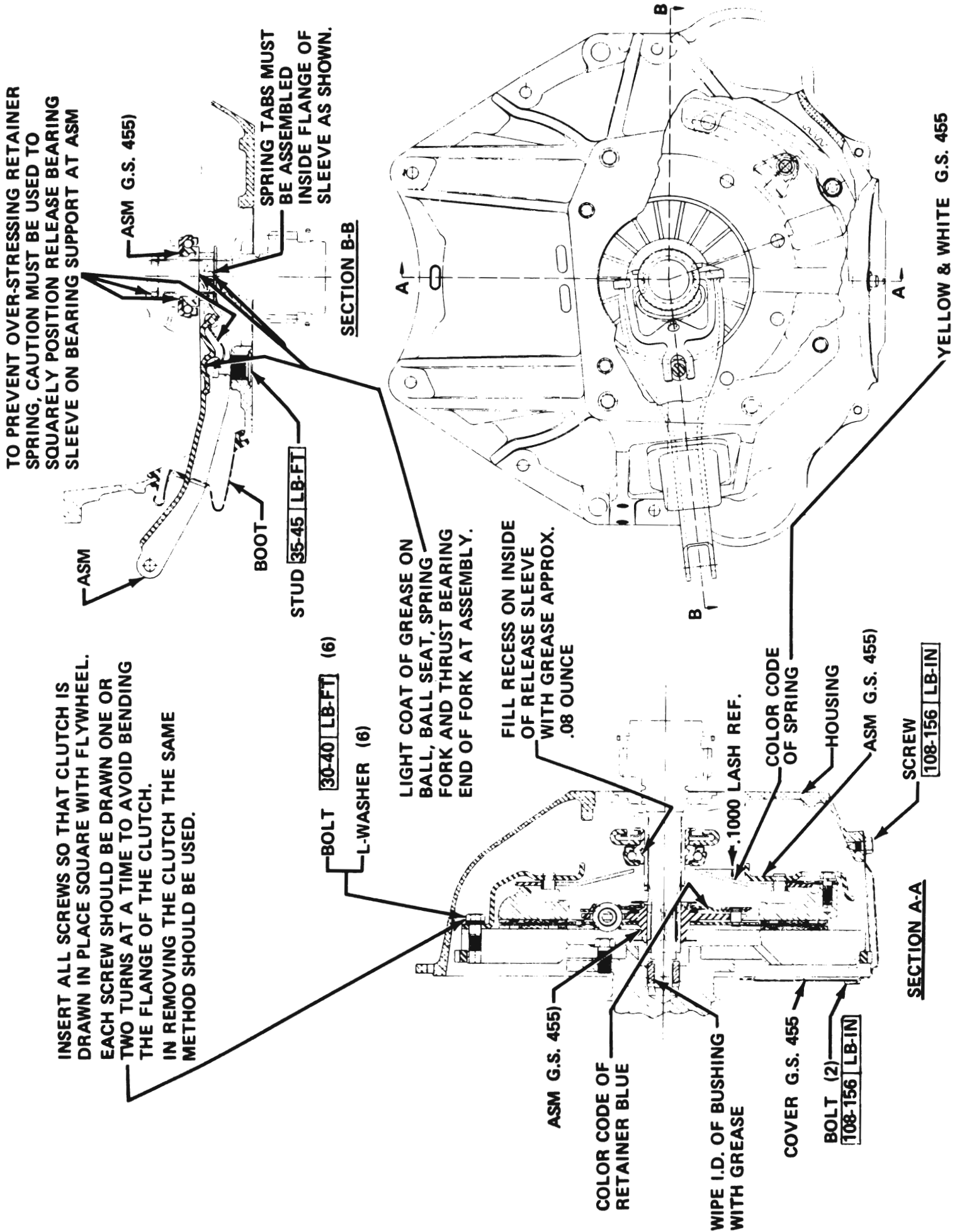

Figure 71-6 Clutch Inner Controls - G.S. (455 Engine)

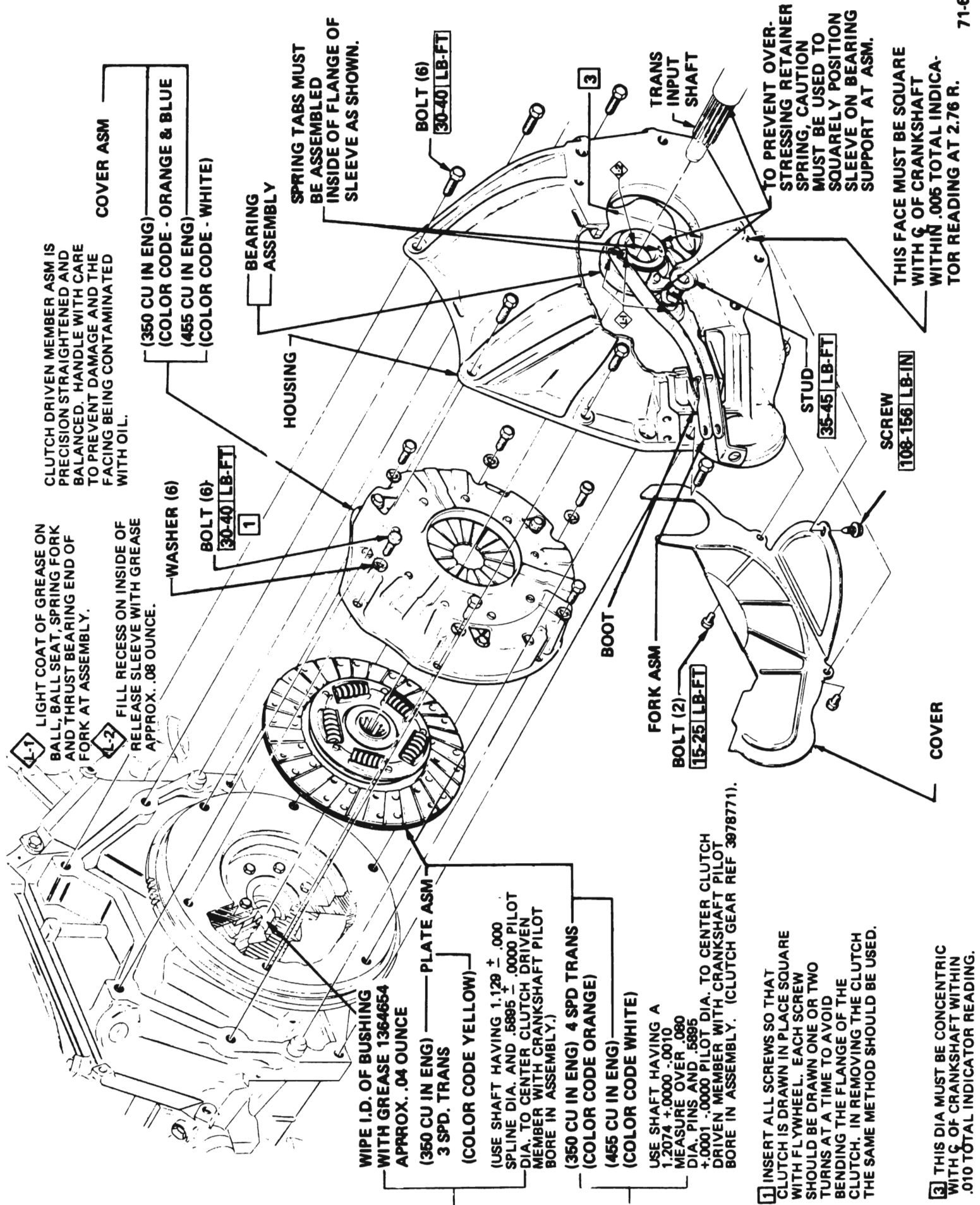

Figure 71-7 Clutch Build-Up