

SECTION B

IGNITION SYSTEM

ALL SERIES

CONTENTS

| Division | Subject | Page No. |
|----------|---|----------|
| I | TROUBLE DIAGNOSIS: | |
| | Ignition System Trouble Diagnosis | 68-15 |
| | Ignition Coil Tests | 68-16 |
| | Distributor Condenser Tests | 68-17 |
| | Ignition System Resistance Tests | 68-18 |
| II | DESCRIPTION AND OPERATION: | |
| | Ignition System Description and Operation | 68-18 |
| III | ADJUSTMENTS AND MINOR SERVICE: | |
| | Replacement of Distributor Points | 68-24 |
| | Ignition Timing | 68-26 |
| | Spark Plug and Wire Service | 68-27 |
| | Distributor Service Operations | 68-28 |
| | Ignition Switch and Lock Repairs | 68-31 |
| IV | REMOVAL AND INSTALLATION: (Not Applicable) | |
| V | OVERHAUL AND MAJOR SERVICE: (Not Applicable) | |
| VI | SPECIFICATIONS: | |
| | Ignition System Specifications | 68-31 |

DIVISION I

TROUBLE DIAGNOSIS

68-13 IGNITION SYSTEM--TROUBLE DIAGNOSIS

If engine trouble has arisen which seems to be due to improper operation of the ignition system, it may be desirable to make a quick preliminary check of the ignition system before making a complete analysis, in order to determine whether the ignition system is actually at fault. The quick checks described in this

paragraph may be used but it must be understood that they are no substitute for the complete ignition system inspection. The checks to be made depend on whether the engine will or will not run.

A. Engine Will Not Run

1. Make quick check of battery and cables if cranking motor does not turn engine at normal cranking speed.
2. Pull coil high tension cable from distributor cap and hold the lead terminal about 3/16" from a clean ground point on engine. If a good spark occurs while

engine is being cranked, the primary circuit and the secondary circuit to this point may be considered to be okay. Proceed with Steps 3 through 6.

3. Remove distributor cap and check interior for moisture, corroded terminal segments, and check terminal sockets for corrosion. Check rotor for corrosion. Clean off corrosion and wipe distributor cap dry. Check for a crack or carbon path in cap or rotor.

4. Inspect ignition cables for possible short circuits and corroded terminals. Remove and inspect spark plugs (paragraph 68-20).

5. If cause of trouble has not been found, check approximate ignition timing (paragraph 68-19).

6. If engine still fails to run, the trouble is probably due to causes other than ignition, such as lack of fuel, carburetion, or compression loss.

7. If spark did not occur at coil high tension lead (Step 2 above) then connect 12-volt test lamp between distributor terminal of coil and ground and crank engine. If test light flickers on and off as engine is cranked the primary circuit is probably okay. Check ignition coil (paragraph 68-14) and condenser (paragraph 68-15).

8. If test light remains on as engine is cranked, contact points are not closing properly; check point opening and ground connection in distributor (paragraph 68-18).

9. If test light remains off as engine is cranked, the primary circuit is open or the points are not opening properly. Check for loose connections, broken leads, defective switch, contact point opening, and primary circuit winding in coil. Visual inspection of points and the use of a test lamp or voltmeter will locate the source of this trouble.

B. Engine Runs, But Not Satisfactorily

1. When missing, loss of power, or hard starting is present a complete checkup of the ignition system is in order, since these conditions may result from anything from a low battery to defective spark plugs, or from other engine conditions not related to ignition. In this case, the complete inspection of ignition system should be used.

2. Detonation may be caused by improper timing (par. 68-18), improper operation of centrifugal or vacuum advance mechanism (paragraph 68-17), worn distributor bearings or a bent shaft, dirty or wrong heat range spark plugs (paragraph 68-20). It may also be caused by overheating, excessive carbon in cylinders, or by *low octane fuel*.

3. Overheating may be caused by one or more of the

conditions which contribute to detonation, as well as by faults in engine cooling system.

68-14 IGNITION COIL TESTS

A. Weak Coils

Most ignition coils that are replaced by service stations are classified by them as weak. Many coils rejected as weak actually test up to specifications and give normal performance.

A coil that actually is weak will first affect engine performance when the ignition reserve is at a minimum. This may be in starting, low speed acceleration or top speed. Eventually the engine will fail to start.

High resistance connections in either the primary or secondary circuit wiring will react the same as a weak coil. Wide spark plug gaps, which require higher voltage than the coil can produce, put the coil under suspicion. High compression and lean carburetion increase the voltage requirements and lead to many needless coil changes. Leakage of high tension current through moisture on an unprotected coil terminal may produce carbon tracks which weaken the coil output voltage. For this reason the nipple on coil high tension terminal must be properly installed and in good condition.

When an ignition coil is suspected of being defective it should be tested as described below before being replaced.

B. Testing Coil for Open and Grounded Circuits

Before using a coil test instrument, the coil should be tested for open and grounded circuits, using a 110-volt test lamp and test points.

1. Apply test points to both primary terminals of coil. If test lamp does not light, the primary circuit is open.

2. Apply one test point to the high tension terminal, and the other test point to one of the primary terminals. If secondary circuit is not open, the lamp will not light but tiny sparks will appear at test points when they are rubbed over terminals. If secondary circuit is open, no sparks will occur.

3. Apply one test point to a clean spot on the metal coil case and touch the other point to the primary and high tension terminals. If the lamp lights, or tiny sparks appear at the points of contact, the coil windings are grounded.

4. A coil with open or grounded windings must be replaced since internal repairs cannot be made. It is unnecessary to test such a coil with instruments. If

windings are not open or grounded, a test for short circuits and other internal defects should be made with a reliable coil test instrument.

C. Coil Test Instruments

Two general types of instruments are used in testing ignition coils. One type makes use of an open or protected spark gap, while the other reports the condition of the coil on a meter.

The spark gap type of tester should always be used comparatively, that is, the questionable coil should be compared with a coil of same model that is known to be good. Both coils must be at the same temperature and identical test leads must be used.

Certain variables caused by altitude, atmosphere or spark gap electrode conditions are usually present in the spark gap type of test.

The meter type testers are usually designed to permit testing the coil without making any connection to the secondary terminal. This eliminates the variables usually present in the spark type of test and avoids the necessity for comparison with a good coil.

Some different makes and models of coil testers differ in their methods of use, as well as in the markings on meters, *the instructions of the manufacturer must be carefully followed when using any coil tester. The instrument must be frequently checked to make certain that it is accurately calibrated.*

Regardless of instrument or method used, the coil must be tested at normal operating temperature because internal defects often fail to show up on a cold test.

68-15 DISTRIBUTOR CONDENSER TESTS

When a condenser is suspected of being faulty it should be tested with a reliable condenser tester to determine whether it is actually the cause of ignition trouble. The condenser should be tested for (a) high series resistance (b) insufficient or excessive capacity (c) low insulation resistance.

A special condenser tester is required to make these tests. When using a condenser tester the instructions of the manufacturer must be carefully followed.

The condenser must be at normal operating temperature when it is being tested.

A. High Series Resistance

High series resistance in the condenser causes the condenser to be slow in taking the charge and, consequently, a higher than normal voltage is developed across the contact points when they first start to open. The higher voltage causes more

disturbance at the contact points, which in turn causes more rapid wear and more tendency toward oxidized surfaces. The condition can become severe enough to cause complete failure of the ignition system. It would first show up during starting and low speed operation.

High series resistance may be caused by internal resistance in condenser or by resistance in the connections. Any defect caused by internal resistance should show up at low mileage since this does not change very much with time or use. *The damaging changes are in the connections, in which looseness, corrosion, or broken strands may develop.*

New condensers may have a series resistance as low as .05 ohm. Some condenser testers are set to reject condensers which have a resistance of .3 ohm; however, test show that the resistance can go to .5 ohm before ignition performance is affected.

B. Insufficient or Excessive Capacity

The condenser specified for use in the Buick ignition system has a capacity of .18 to .23 microfarads.

If a condenser is used which does not have the specified capacity of .18 to .23 microfarads, excessive pitting of one contact point and a corresponding buildup of metal on the other contact point will result. A condenser having insufficient capacity will cause build-up of metal on the breaker arm (positive) point. A condenser having excessive capacity will cause build-up of metal on the contact support (negative) point.

In exceptional cases, pitting and metal buildup on contact points may be experienced even when condenser capacity is within the specified limits. In such cases the life of contact points will be improved by installing a condenser of high-limit capacity if metal build-up is on breaker arm point, or a condenser of low-limit capacity if metal build-up is on contact support point. There is usually sufficient variation in the capacities of stock condensers to permit selection of a high or low limit condenser by testing the available stock.

C. Low Insulation Resistance

A weak or leaking condenser is usually one that has absorbed water so that the insulation resistance of the winding is lowered to the extent that the condenser will not hold a charge satisfactorily. A condenser with low insulation resistance will drain sufficient energy from the ignition system to lower the secondary voltage seriously. The condenser specified for use in the Buick ignition system is sealed to prevent absorption of water, and no other type should be used.

A leaky condenser usually does not affect engine

performance except when hot. It is unlikely that a condenser with low insulation resistance would cause missing at low or medium speeds under conditions where the condenser does not get hot. A condenser that has low enough resistance to affect engine performance when cold would probably be indicated as broken down on most condenser testers.

Condenser testers equipped to check condensers for low insulation resistance usually give a reading in megohms, a megohm being one million ohms. The scale is marked to indicate whether the condenser is good or bad.

When testing a condenser for low insulation resistance the lead should always be disconnected from the distributor. Since the distributor terminals and the connected circuit have much lower insulation resistance than the condenser, failure to disconnect the condenser lead will give a reading much too low.

68-16 IGNITION SYSTEM RESISTANCE TEST

Check for proper functioning of the resistance in the primary ignition circuit by turning on the ignition. With the engine not running, a voltmeter connected from the battery side of the coil to ground should read approximately 5 to 5.5 volts. If the reading is a full 12 volts, the ignition points may be open; "bump" the starter a few times until the engine comes to rest with the ignition points closed and again check for a 5.5 volt reading. A reading of 12 volts or over for all engine positions would indicate that the shorting switch is making contact all the time; this condition must be corrected immediately or ignition point life will be very short.

Check for proper closing of the shorting switch and also for proper functioning of the complete starting circuit by grounding the secondary coil wire so the engine won't start. With the engine cranking, a voltmeter connected from the battery side of the coil to ground should read at least 9 volts. A reading of under 5 volts would indicate that the shorting switch is not closing; this condition would result in hard cold starting.

Briefly, the advantages of our resistance with shorting switch system are: it sends full battery voltage to the coil for good cold weather starting, and it cuts down the voltage to the coil with the engine running for long ignition point life.

Discourage any attempts to measure voltage at the coil with the engine running; because of variations in current flow at high speeds and in regulated voltage, this check would be meaningless. Voltage readings on a perfectly-functioning ignition system may go over 11 volts.

DIVISION II

DESCRIPTION AND OPERATION

68-17 IGNITION SYSTEM DESCRIPTION AND OPERATION

A. Ignition System General Description

The ignition system (Figure 68-13) consists of the ignition coil, condenser, ignition distributor, ignition switch, low and high tension wiring, spark plugs, and a source of electrical energy (battery or generator).

The ignition system has the function of producing high voltage surges and directing them to the spark plugs in the engine cylinders. The sparks must be timed to appear at the plugs at the correct instant near the end of the compression stroke with relation to piston position. The spark ignites the fuel-air mixture under compression so that the power stroke follows in the engine.

There are two separate circuits through the ignition system. One of these is the primary circuit which includes the ignition switch, primary winding of the ignition coil, distributor contact points, and condenser. The other is the secondary, or high tension circuit, which includes the secondary winding of the ignition coil, the high tension lead, distributor cap, rotor, and spark plug.

B. Basic Operation of Ignition System

The basic operation is described as follows:

With the switch closed, current flows through the primary circuit, that is, from the battery through the primary winding of the ignition coil and closed distributor contacts to ground, and then back to the battery. A cam mounted on the rotating distributor shaft causes the distributor contacts to open and close. When the contacts open, the current decreases very rapidly in the ignition coil primary winding, and a high voltage is induced in the coil secondary winding.

This high voltage is impressed through the distributor cap and rotor across one of the spark plugs. As the voltage establishes an arc across the spark plug electrodes, the air-fuel mixture in the cylinder is ignited to provide the power stroke. The secondary electrons flow from the coil secondary winding, across the distributor rotor gap and spark plug gap, and then back to the secondary winding through ground, the battery, and switch. The distributor contacts then reclose, and the cycle repeats. The next-firing spark plug then will be the one connected to the distributor cap insert that is aligned with the rotor when the contacts separate. With the engine running, current

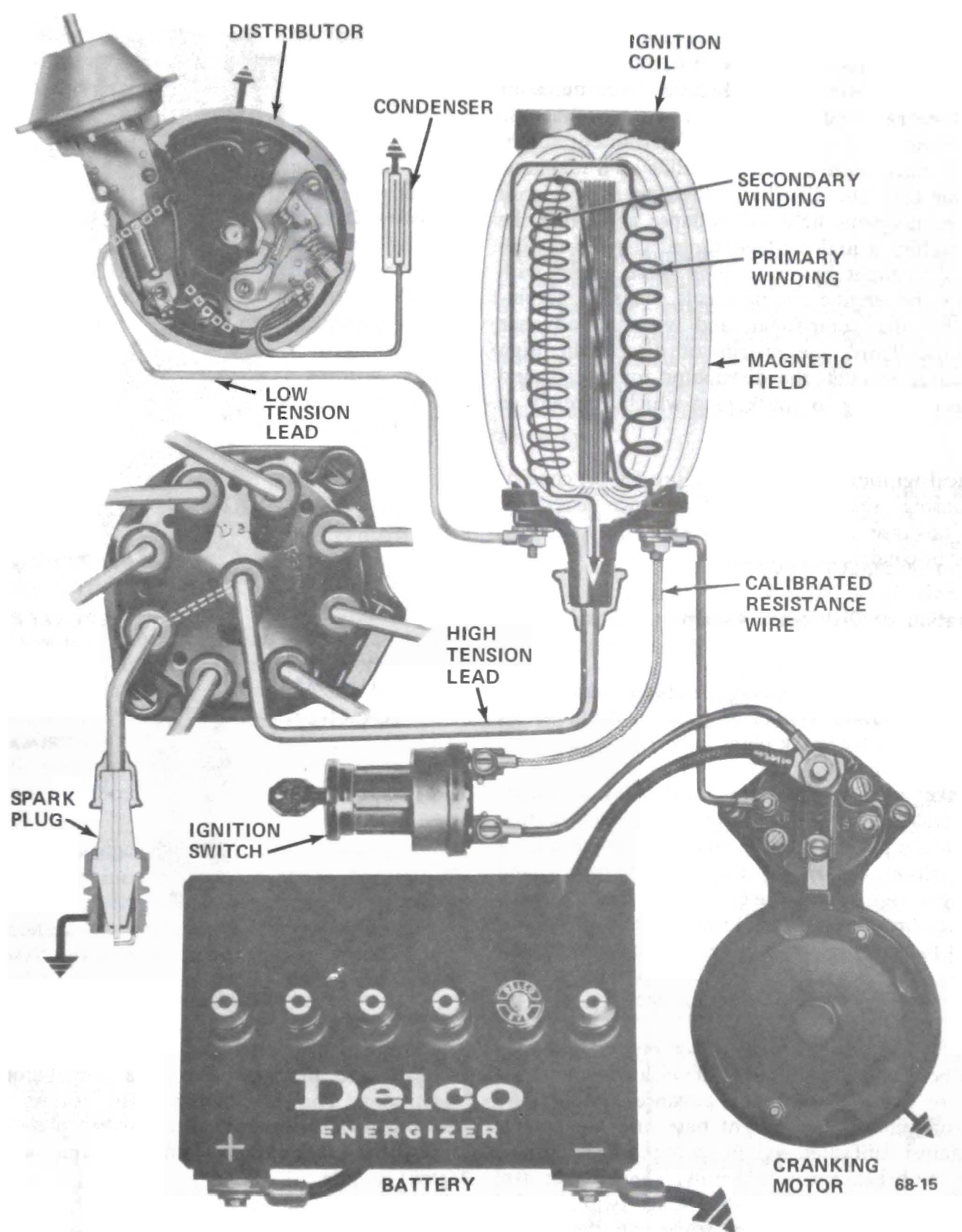

Figure 68-13 Ignition System

flows through the coil primary calibrated resistance wire; the other lead connected between the coil and solenoid terminal is a by-pass feature that will be covered in the section entitled "Ignition Coils".

When the contacts separate, a high voltage is induced in the coil primary winding. This voltage may be as

high as 250 volts, which causes an arc to form across the distributor contacts. To bring the primary current to a quick controlled stop, and in order to greatly reduce the size of the arc and thereby insure prolonged contact point life, a capacitor (condenser) is connected across the distributor contacts.

C. Description of Distributors

The distributor has three jobs. First, it opens and closes the low tension circuit between the source of electrical energy and the ignition coil so that the primary winding is supplied with intermittent surges of current. Each surge of current builds up a magnetic field in the coil. The distributor then opens its circuit so that the magnetic field will collapse and cause the coil to produce a high voltage surge. The second job that the distributor has is to time these surges with regard to the engine requirements. This is accomplished by the centrifugal and vacuum advance mechanisms. Third, the distributor directs the high voltage surge through the distributor rotor, cap, and high tension wiring to spark plug which is ready to fire.

The typical ignition distributor (Figure 68-14) consists of a housing, shaft, centrifugal advance assembly, vacuum advance assembly, breaker plate assembly, capacitor or condenser, and rotor.

D. Operation of Distributor Assembly - Basic Features

The cap, rotor, and high voltage leads in a distributor form a distribution system that conveys the high voltage surges to the spark plugs in correct sequence.

The breaker plate contains the breaker lever, contact support, and capacitor. When the breaker cam rotates, each cam lobe passes by and contacts the breaker lever rubbing block, separating the contact points and producing a high voltage surge in the ignition system. With every breaker cam revolution, one spark will be produced for each engine cylinder. Since each cylinder fires every other revolution in a four-cycle engine, the distributor rotates at one-half engine speed.

The shaft and weight base assembly is fitted in suitable bearings made of such materials as cast iron, bronze, or iron. Centrifugal advance weights are pivoted on studs in the weight base and are free to move against calibrated weight springs which connect them to the breaker cam assembly. The breaker cam assembly fits on the top of the shaft (slip fit) and rotates with the shaft, being driven by the weight springs actuated by the advance weights.

Outward movement of the weights advances the cam assembly in relation to the shaft as engine speed is increased, providing an earlier spark. Each engine model requires an individual spark advance cam design to insure delivery of the spark at the right instant for maximum power at all speeds. Because of this, very little standardization of complete distributors can be made.

It is possible to improve fuel economy on engines operating under part-throttle conditions by supplying

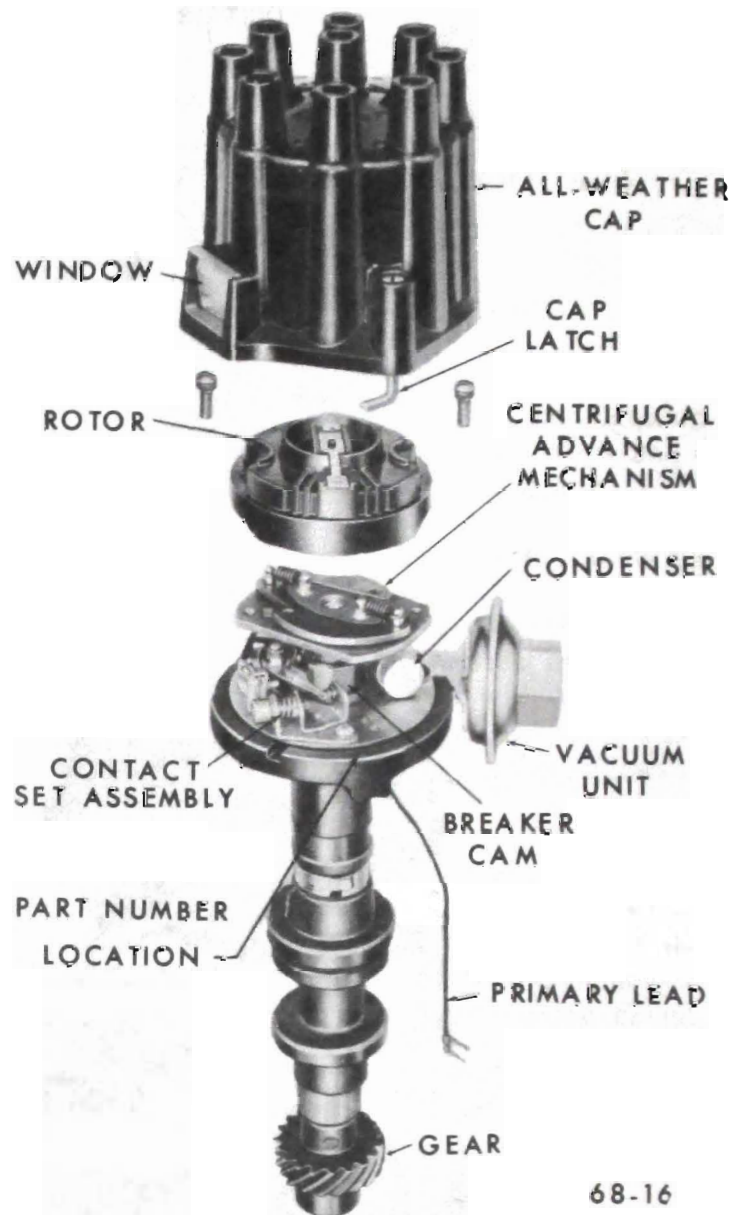

Figure 68-14 Distributor Assembly

additional spark advance. Vacuum advance mechanisms are provided on some distributors for this purpose. The mechanism used rotates either the complete distributor or the breaker plate in order to time the spark earlier when the engine is operating at part throttle.

E. Centrifugal Advance

The centrifugal advance mechanism times the high voltage surge produced by the ignition coil so that it is delivered to the engine at the correct instant, as determined by engine speed.

When the engine is idling, the spark is timed to occur in the cylinder just before the piston reaches top dead center. At higher engine speeds, however, there is a shorter interval of time available for the fuel-air mixture to ignite, burn, and give up its power to the piston. Consequently, in order to obtain the maximum

amount of power from the mixture, it is necessary at higher engine speeds for the ignition system to deliver the high voltage surge to the cylinder earlier in the cycle.

To illustrate this principle, assume that the burning time of a given gas mixture in an automotive engine is .003 of a second. To obtain full power from combustion, maximum pressure must be reached while the piston is between 10 degrees and 20 degrees past top dead center. At 1,000 engine RPM the crankshaft travels through 18 degrees in .003 of a second, at 2,000 RPM the crankshaft travels through 36 degrees. See Figure 68-15. Since maximum pressure point is fixed, it is easy to see why the spark must be delivered into the cylinder earlier in the cycle in order to deliver full power, as engine speed increases.

As previously mentioned, the timing of the spark-to-engine speed is accomplished by the centrifugal advance mechanism, which is assembled on the distributor shaft. The mechanism consists primarily of two weights and a cam assembly. The weights throw out against spring tension, as engine speed increases. This motion of the weights turns the cam assembly so that the breaker cam is rotated in the direction of shaft rotation to advanced position, with respect to the distributor drive shaft. The higher the engine speed, the more the weights throw out and the further the breaker cam is advanced. See Figure 68-16.

The centrifugal advance required varies considerably between various engine models. In order to determine the advance for a given engine, the engine is operated on a dynamometer at various speeds with a wide-open throttle. Spark advance is varied at each speed until the range of advance that gives maximum power is

found. The cam assembly weights and springs are then selected to give this advance. Timing, consequently, varies from no advance at idle to full advance at high engine speed where the weights reach the outer limits of their travel.

F. Vacuum Advance

Under part-throttle operation a high vacuum develops in the intake manifold and a smaller amount of air and gasoline enters the cylinder. Under these conditions, additional spark advance (over and above advance provided by the centrifugal advance mechanism) will increase fuel economy. In order to realize maximum power, ignition must take place still earlier in the cycle.

To provide a spark advance based on intake manifold vacuum conditions, many distributors are equipped with a vacuum advance mechanism. The mechanism has a spring-loaded diaphragm connected by linkage to the distributor. The spring-loaded side of the diaphragm is air-tight and is connected in many cases by a vacuum passage to an opening in the carburetor. See Figure 68-17. This opening is on the atmospheric side of the throttle when the throttle is in the idling position. In this position, there is no vacuum in the passage.

When the throttle is partly opened, it swings past the opening of the vacuum passage. Intake manifold vacuum then can draw air from the air-tight chamber in the vacuum advance mechanism and this causes the diaphragm to be moved against the spring. This motion is transmitted by linkage to the distributor breaker assembly, causing it to rotate. The amount of distributor breaker assembly rotation is governed by

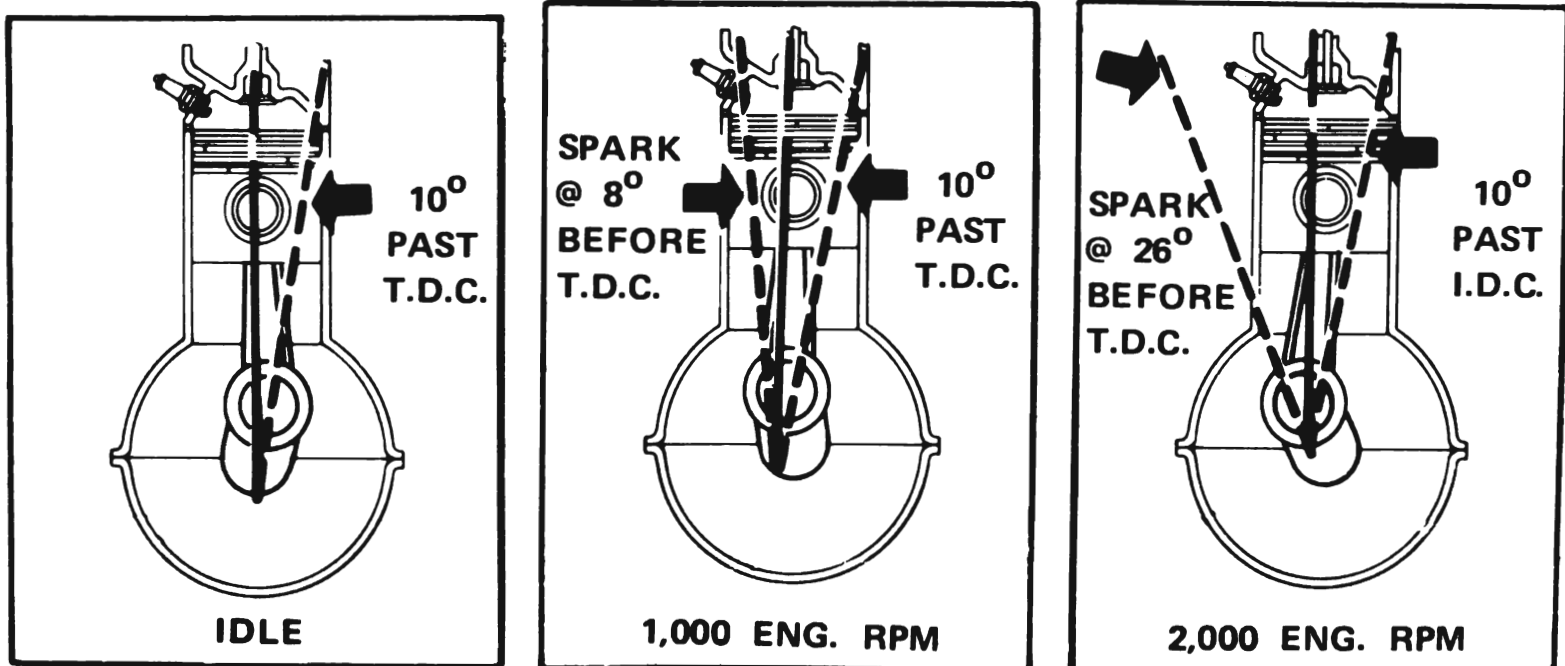
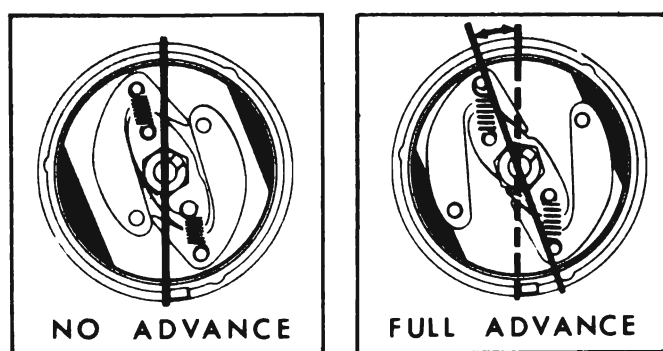
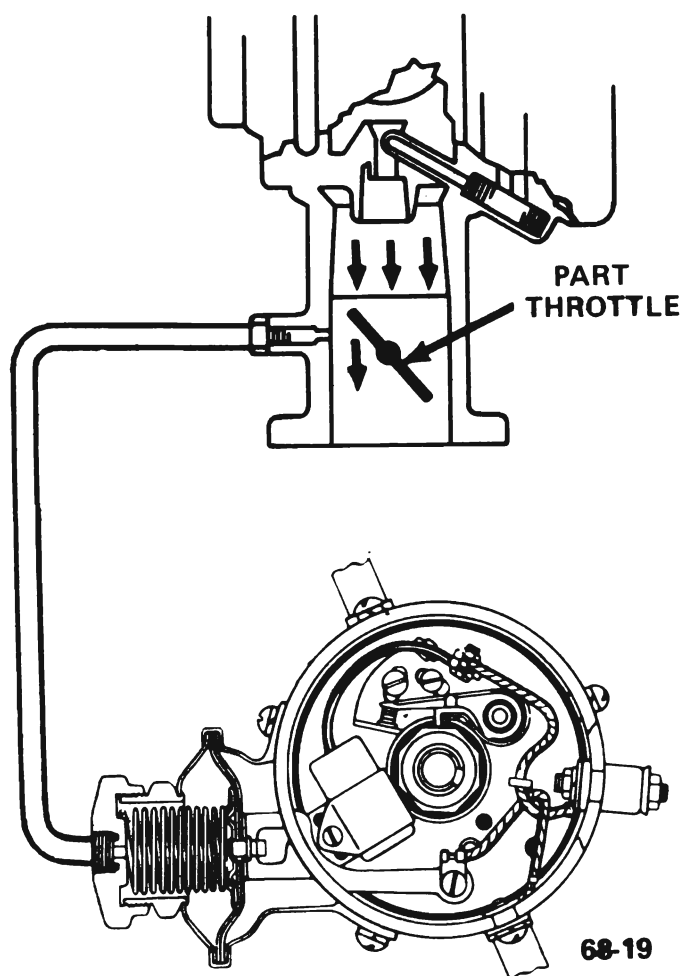

Figure 68-15 Spark Timing



68-18

Figure 68-16 Centrifugal Advance



68-19

Figure 68-17 Vacuum Advance Mechanism

the amount of vacuum in the intake manifold up to the limit imposed by the design of the vacuum advance mechanism.

When the distributor breaker plate assembly is rotated, the contact points are carried around the breaker cam to an advanced position so that the breaker cam contacts the rubbing block and closes and opens the points earlier in the cycle. This provides a spark advance based on the amount of vacuum in the intake manifold. Thus, for varying compressions in the cylinder, the spark advance will vary, permitting

greater economy of engine operation. It should be recognized that the additional advance provided by vacuum control is effective in providing additional economy only on *part-throttle* operation.

At any particular engine speed there will be a certain definite advance, resulting from operation of the centrifugal advance mechanism, plus a possible additional advance, resulting from operation of the vacuum advance mechanism. For example, an initial timing advance of 5 degrees, plus a centrifugal advance of 10 degrees, makes a total of 15 degrees advance at 40 miles an hour. If the throttle is only partly opened, an additional vacuum advance of up to 15 degrees more may be obtained, making a total of 30 degrees. When the throttle is wide open, there is no appreciable vacuum in the intake manifold, so this additional advance will not be obtained. All advance then is based on engine speed alone and is supplied by the centrifugal advance mechanism.

The vacuum advance mechanism is an economy device which will increase fuel economy when properly used. The driver who drives with wide-open throttle, whether in low or high gear, will not obtain this additional advance with its resulting increased fuel economy.

G. Cam Angle

The cam angle, often referred to as contact angle or dwell angle, is the number of degrees of cam rotation during which the distributor contact points remain closed. See Figure 68-18. It is during this period of cam rotation that the current in the primary winding increases. Although the cam angle may not change, the length of time the contacts remain closed becomes less and less, as the engine speed increases. At higher engine speeds, the ignition coil primary current does not reach its maximum value in the short length of time the contacts are closed. In order to store the maximum amount of energy obtainable in the coil and, consequently, obtain sufficient energy to fire the plug, it is necessary to design a breaker lever assembly that will operate properly at high speeds. Most Delco-Remy distributors are equipped with a special high rate-of-break cam and a special high-speed breaker lever which is capable of following the cam shape at high speeds without bouncing. The high rate-of-break cam separates the contact points faster for each degree of rotation and permits closing earlier, thus, increasing cam angle. With the special cam and breaker lever combination, it is possible to obtain the maximum cam angle and, consequently, optimum ignition performance at high speeds.

The point opening is the maximum distance that occurs between the separated contacts as the cam rotates. If the cam angle is properly set, the point opening most likely will also be according to

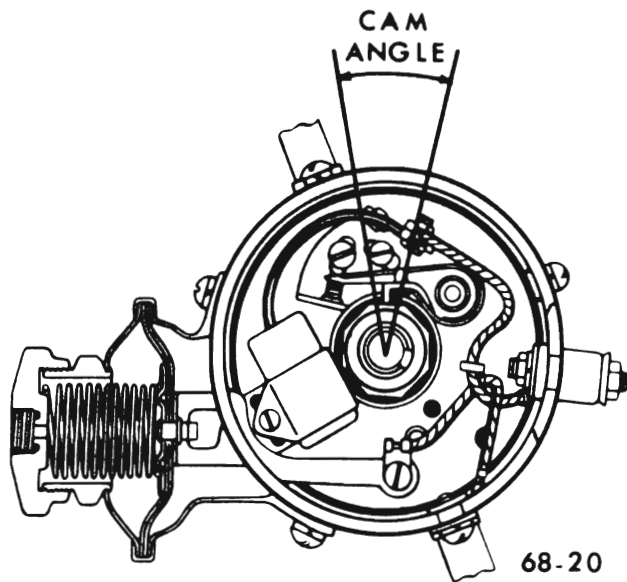

Figure 68-18 Cam Angle

specifications. In some cases, it may be necessary to measure point opening, in addition to cam angle, to insure that the contacts are properly set. A feeler gauge on new contacts, or a dial indicator on used contacts, may be used to measure point opening.

H. Ignition Condenser (Capacitor)

The capacitor consists of a roll of two layers of thin metal foil separated by a thin sheet or sheets of insulating material. See Figure 68-19. This assembly is sealed in a metal can with a flat spring washer providing a tight seal.

The high voltage induced in the coil primary causes the capacitor plates to charge when the contacts first separate; the capacitor acts initially like a short circuit

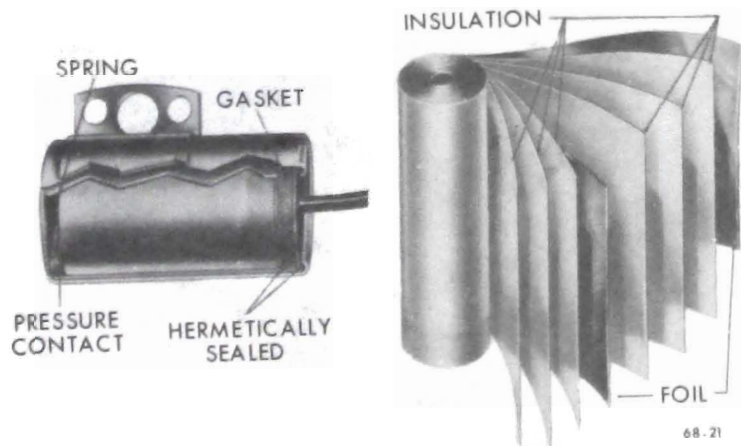

Figure 68-19 Ignition Condenser

and current flows into the capacitor to minimize arcing at the contacts.

i. Ignition Coils

An ignition coil is a pulse transformer that steps up the low voltage from the battery or generator to a voltage high enough to ionize the spark plug gap and ignite the air-fuel mixture in the cylinder. A typical coil is made up of a primary winding, consisting of a few hundred turns of relatively large wire, and a secondary winding, consisting of many thousand turns of very small wire. See Figure 68-20. These windings are assembled over a soft iron core and are enclosed by a soft iron shell. This assembly is inserted into a one-piece, steel or diecast aluminum coil case, which is filled with oil and hermetically sealed by a coil cap made of molded insulating material. The cap contains the primary and secondary high voltage terminals.

All Delco-Remy ignition coils are hermetically sealed to prevent the entrance of moisture which would cause coil failure. During manufacture, the coil case also is filled with oil at a high temperature. As the oil

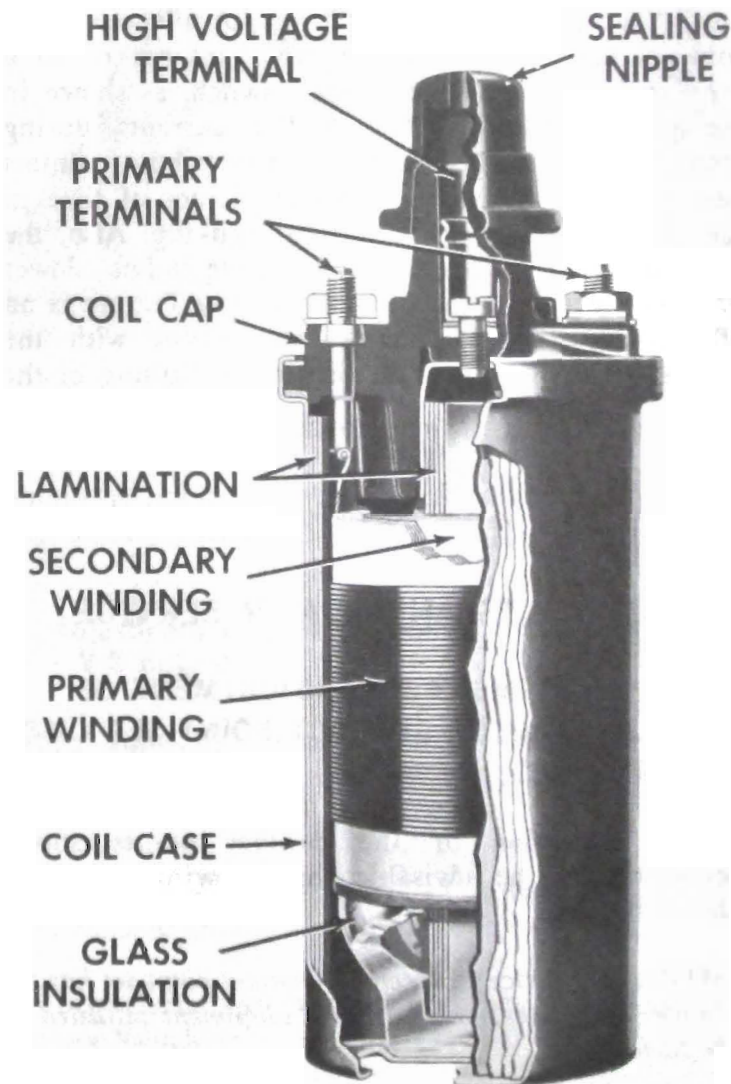

Figure 68-20 Ignition Coil

temperature decreases to more nearly match the temperature of the surrounding air, the oil contracts to occupy less volume, thus allowing room for expansion when the coil heats up during normal operation. The oil acts as an insulator to prevent high voltage arc-over within the coil.

In the design of an ignition system, sufficient primary circuit resistance must be present to protect the distributor contacts from excessive arcing and burning. In some ignition systems, part of this resistance may take the form of a separate resistor or a calibrated resistance wire connected between the ignition switch and the coil primary terminal. Since the value of this resistor, along with the resistances of the other components in the entire primary circuit, affects the coil performance at higher engine speeds, a 12-volt coil used on a 6-volt system without the external resistor, will not provide equal performance results. In other words, a 12-volt coil without the resistor is not necessarily a 6-volt coil.

During cranking, the external resistance on most applications is by-passed to provide full battery voltage to the coil for improved performance and easier starting. The by-pass wire may be connected to an "R" terminal on the cranking motor solenoid which contacts the contact disk during cranking, or to a separate terminal on the ignition switch, as shown in the previous section. The higher currents during cranking are not sufficient to cause distributor contact deterioration because of the short periods of time in the life of contacts spent during cranking. Also, the lowered battery voltage during cranking causes a lower primary current, so the resistor by-pass feature is an offsetting factor. By-passing the resistor with the engine operating will cause very rapid failure of the distributor contacts.

DIVISION III

ADJUSTMENTS AND MINOR SERVICE

68-18 REPLACEMENT AND ADJUSTMENT OF DISTRIBUTOR CONTACT POINT SET - V-8 ENGINES

When inspection of the contact points shows replacement to be advisable, the following procedure should be used.

NOTE: *The service replacement contact point set has the breaker spring tension and point alignment adjusted at the factory.*

A. Removal of Contact Point Set

In 1971, Buick distributors have installed an ignition

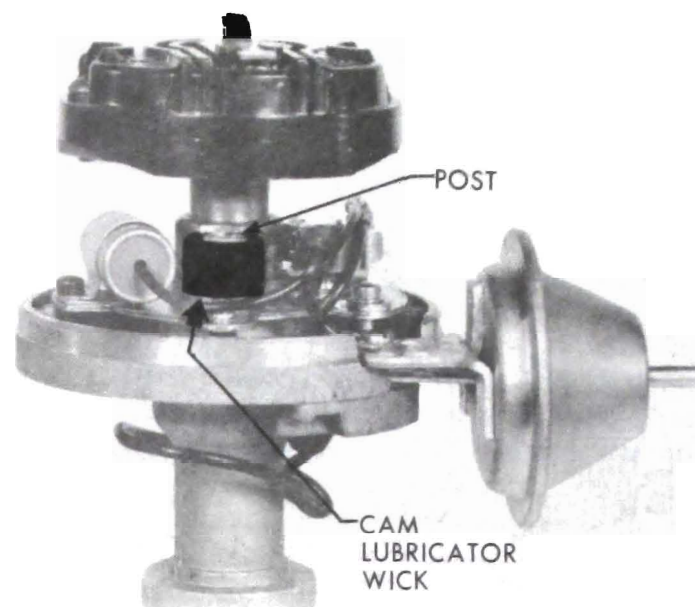

68-23

Figure 68-21 Cam Lubricator Wick

point shield. The purpose of this device is to shield the windshield antenna from picking up ignition point interference. See Figure 68-19.

When replacing ignition points, the snap lock type connector points must be used, as the screw fastened type will interfere with the ignition shield.

Should the points come in contact with the shield a short circuit will result.

1. Remove distributor cap by inserting a screwdriver in upper slotted end of cap retainers, press down and turn 90 degrees counterclockwise. Push distributor cap aside and remove rotor.

2. Loosen two screws and lock washers which hold the contact point set in place. Then remove point set.

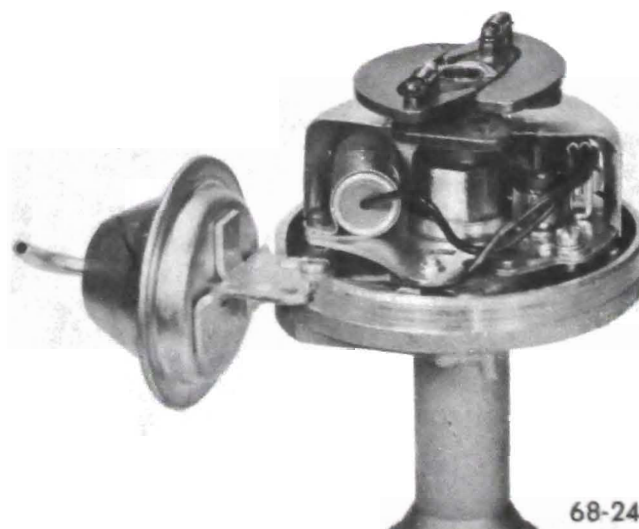

68-24

Figure 68-22 Distributor Ignition Point Shield

3. Disconnect the condenser and primary leads from their terminal by loosening the retaining screw. If there is no retaining screw, simply slip leads out.

B. Installation of Contact Point Set

1. Remove old cam lubricator wick and discard. Install a new lubricator, working it down over post by using a small nail in a circular direction around the post.

2. Remove two screws holding ignition point shield. See Figure 68-23.

3. Remove shield from distributor assembly. See Figure 68-24.

4. Install condenser and primary leads.

5. Slide contact point set over boss on breaker plate and under the two screw heads. Tighten two screws and lock washers.

Leads must be properly positioned so they will not come in contact with bottom of weight base or rotor.

6. Install ignition point shield, making sure of correct positioning to insure against leakage and a short circuit. See Figure 68-25.

7. If engine does not start readily, position contact arm rubbing block on peak of cam lobe, insert a 1/8" Allen wrench in adjusting screw and turn screw in (clockwise) until contact points just close. Then back screw out (counterclockwise) 1/2 turn (180 degrees) to

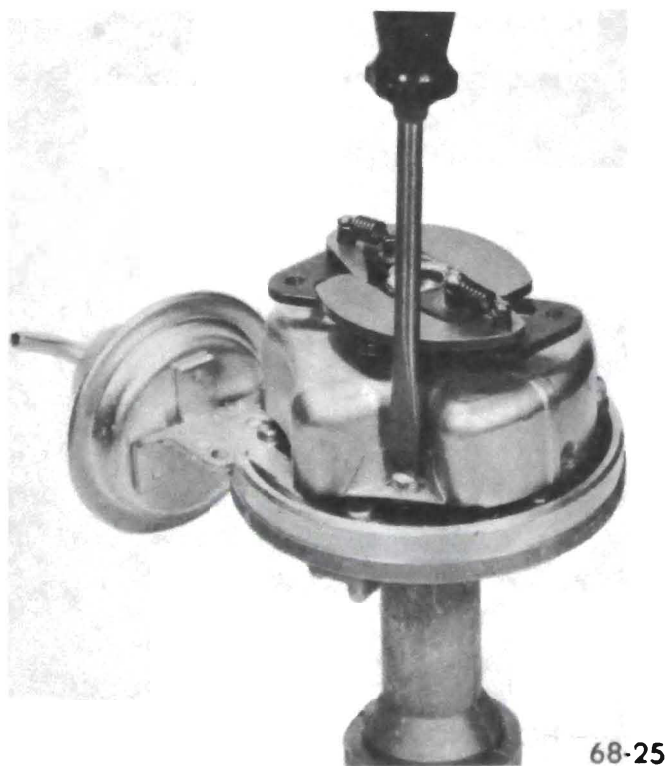

Figure 68-23 Removing Screws

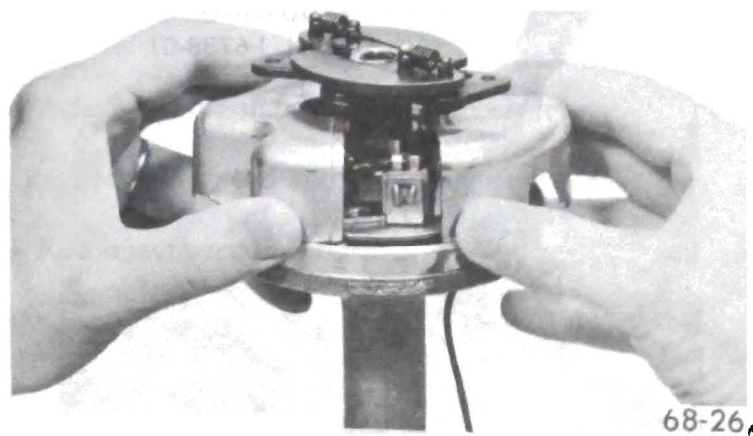

Figure 68-24 Removing Shield

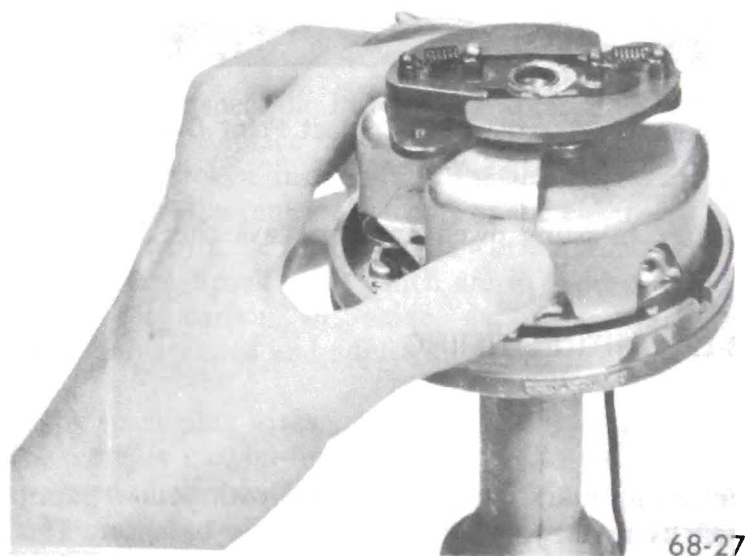

Figure 68-25 Installing Ignition Point Shield

obtain a point gap of approximately .016" for a preliminary setting.

C. Adjustment of Contact Points - Engine Running - V-8 Engines

When adjusting contact point dwell angle, always follow the instructions which come with the dwell meter.

1. Connect dwell tester leads: red to distributor side of coil, black to ground.

2. Turn selector switch to position for 8-lobe cam Turn ignition switch on.

3. Start engine. Lift adjustment window and insert 1/8" Allen wrench in adjusting screw. See Figure 68-26. Set dwell angle at 30 degrees.

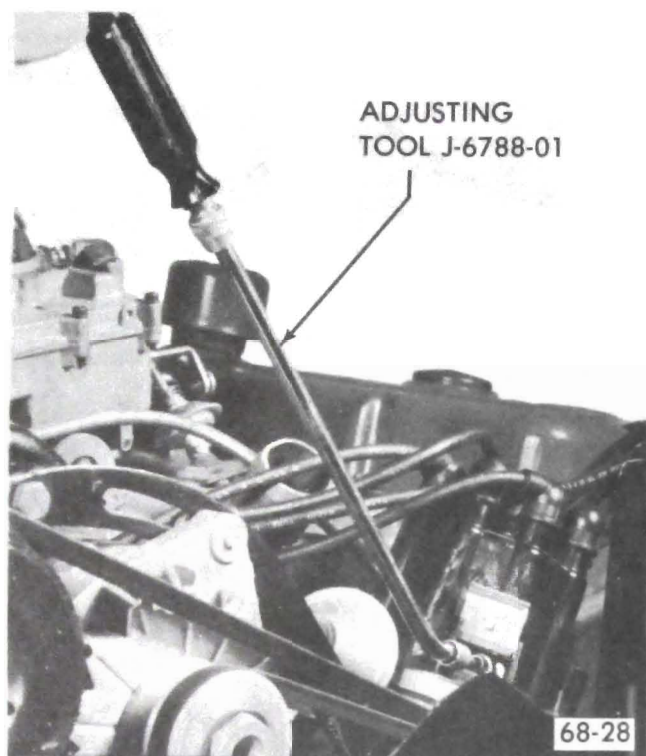

Figure 68-26 - Adjusting Contact Point Dwell Angle
- V-8 Engines

4. After adjusting dwell angle, always check ignition timing.

68-19 IGNITION TIMING

A. V-8 Engines

The timing mark is a groove filled with yellow paint, which is in the edge of the harmonic balancer. The timing indicator, a part of the timing chain cover, has ridges outlined with yellow paint. See Figure 68-27.

B. Preliminary Timing (Engine Won't Run)

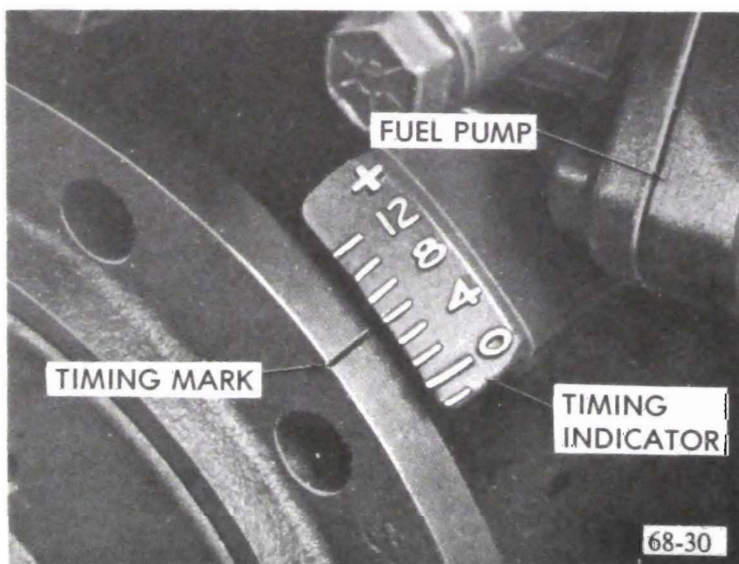

Figure 68-27 - Ignition Timing Mark and Indicator

To time the ignition on any engine which will run, use subparagraph b only. However, if the timing of an engine is completely off, the following procedure must first be used to get the engine to run.

1. With No. 1 spark plug removed and with hole plugged, rotate crankshaft in a forward direction using a suitable wrench on the harmonic balancer to crankshaft bolt. When plug blows from No. 1 cylinder, continue rotation until timing mark on balancer is aligned with proper mark on timing indicator. See Figure 68-27. No. 1 cylinder is now in position to fire.

2. Install distributor in engine with rotor in position to fire No. 1 cylinder and with vacuum control in position to connect vacuum hose. See Figure 68-28. Install distributor clamp and bolt with lock washer, leaving bolt just loose enough to allow movement of distributor with hand pressure.

If distributor does not seat in engine block, press down lightly on distributor housing while cranking engine with starter. After distributor tang snaps into slot in oil pump shaft, start timing again from Step 1, leaving distributor installed.

3. Connect primary wire to coil.

4. Rotate distributor counterclockwise slightly until contact points just start to open. This must be done very carefully or engine will not start.

5. Install distributor cap. Make sure that spark plug wires are correctly installed in distributor cap, through



Figure 68-28 - Installing Distributor in Engine

clips on rocker arm covers, and on spark plugs. See Figure 68-29.

C. Finish Timing (Engine Running)

Contact point dwell angle should always be checked before adjusting ignition timing.

1. Connect a 12-volt power timing light to No. 1 spark plug, following the instructions of the instrument manufacturer. Be careful not to puncture wire or boot as this would start a high voltage leak.

2. Connect a tach-dwell meter from distributor terminal of coil to ground.

3. Adjust contact point dwell angle. While engine is warming up, make certain that spark plug wires are pushed all the way down into the distributor cap terminal and onto the spark plugs. Nipples must be pushed firmly over the terminals and boots over the spark plugs. If any shock is received, secondary insulation is defective and must be replaced.

4. Leave engine running until upper radiator inlet is hot and choke valve is wide open. On automatic transmission cars, place a block in front of a front wheel and apply parking brake firmly, then shift transmission into drive.

5. Adjust idle speed. See paragraph 64-5.

6. Disconnect vacuum hose from vacuum advance unit and plug with a pencil.

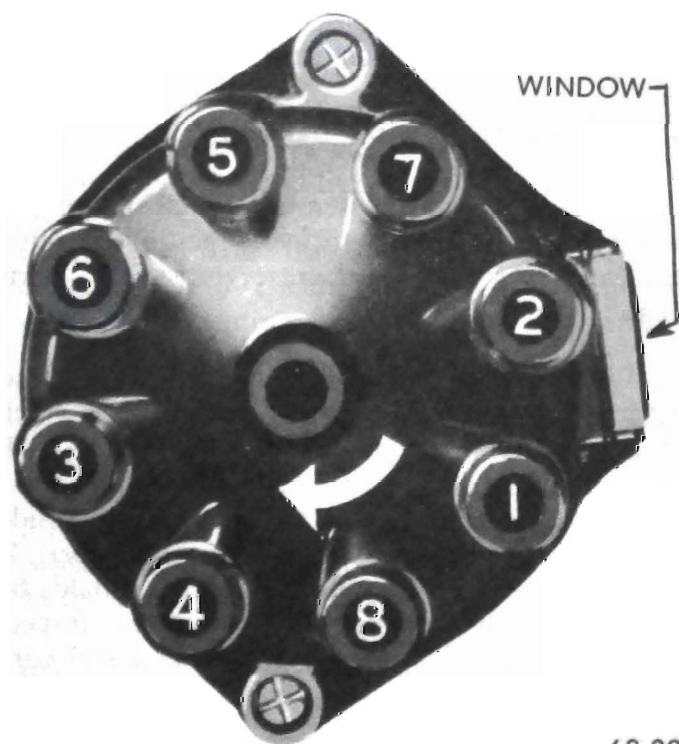

68-33

Figure 68-29 - Installing Spark Plug Wires in Cap - V-8 Engines

7. Direct beam of timing light on the timing indicator and edge of harmonic balancer. Turn distributor slowly until yellow mark on balancer is at specified degree mark on timing indicator on any V-8 engine car.

8. Recheck timing mark. Reset if necessary.

9. Recheck idle speed and mixture adjustments.

10. Reconnect vacuum hose.

68-20 SPARK PLUG AND WIRE SERVICE

A. Remove and Inspect Spark Plugs and Wires

1. To disconnect wires, pull only on boot because pulling on wire might cause separation of the core of the wire. Remove spark plugs and gaskets using a 5/8 deep socket on R45TS plugs. Use care in this operation to avoid cracking spark plug insulators.

2. Carefully inspect the insulators and electrodes of all spark plugs. Replace any spark plug which has a cracked or broken insulator. If the insulator is worn away around the center electrode, or the electrodes are burned or worn, the spark plug is worn out and should be discarded. Spark plugs which are in good condition except for carbon or oxide deposits should be thoroughly cleaned and adjusted.

3. The spark plug wires are of a special resistance type. The core is carbon-impregnated linen. This wire is designed to eliminate radio and television interference radiation, but is also superior in resistance to cross-fire. The resistance type wire, however, is more easily damaged than copper core wire. For this reason care must be taken that the spark plug wires are removed by pulling on the spark plug boots rather than on the wire insulation. Also, when it is necessary to replace a spark plug boot, the old boot should be carefully cut from the wire and a small amount of silicone lubricant used to aid in installing the new boot. If the wire is stretched, the core may be broken with no evidence of damage on the outer insulation. The terminal may also pull off the wire. If the core is broken, it will cause missing. In the case of wire damage, it is necessary to replace the complete wire assembly as a satisfactory repair cannot be made.

4. Wipe ignition wires with cloth moistened with kerosene, and wipe dry. Bend wires to check for brittle, cracked, or loose insulation. Defective insulation will permit missing or cross-firing of engine, therefore defective wires should be replaced.

5. If the wires are in good condition, clean any terminals that are corroded and replace any terminals that are broken or distorted. Replace any broken or deteriorated cable nipples or spark plug boots.

Spark plug wires have a built-in resistance of approximately 2000 ohms per foot. However, even the longer wires should never have a total resistance over 20,000 ohms; a wire having more than 20,000 ohms resistance should be replaced.

B. Spark Plug Cleaning

Spark plugs which have carbon or oxide deposits should be cleaned in a blast type spark plug cleaner. Scraping with a pointed tool will not properly remove the deposits and may damage the insulator. If spark plugs have a wet or oily deposit dip them in a degreasing solvent and then dry thoroughly with dry compressed air. Oily plugs will cause the cleaning compound to pack in the shell.

Carefully follow the instructions of the manufacturer of the cleaner being used, cleaning each plug until the interior of shell and the entire insulator is clean; however, *avoid excessive blasting*.

Examine interior of plug in good light. Remove any cleaning compound with compressed air. If traces of carbon oxide remain in plug, finish the cleaning with a light blasting operation. Clean firing surfaces of center and side electrodes with several strokes of a fine file.

When spark plugs have been thoroughly cleaned, carefully inspect for cracks or other defects which may not have been visible before cleaning.

C. Adjusting Spark Plug Gap

Use round wire feeler gages to check the gap between spark plug electrodes of used plugs. Flat feeler gages will not give a correct measurement if the electrodes are worn. Adjust gap by bending the *side* electrodes only; bending the center electrode will crack the insulator. Adjust gaps to .040". Setting spark plug gap to any other specification to improve idle or effect other changes in engine performance is not recommended.

D. Installation of Spark Plugs

When installing R45TS spark plugs, tighten to 15 lb.ft., using a 5/8" deep socket, an extension and a torque wrench. If tapered seat spark plugs are overtightened, they will be very difficult to remove at the next tune-up.

E. Installation of Spark Plug Wires

No. 1 spark plug wire is installed in the first distributor cap tower after the adjusting window, moving in the direction of rotation (V-8). The other wires are then installed in a clockwise direction according to the firing order. See Figure 68-29.

68-21 DISTRIBUTOR SERVICE OPERATIONS

A. Removal and Disassembly of Distributor for Inspection - V-8 Engines

1. Disconnect the distributor primary wire from coil and disconnect hose from vacuum unit. Remove distributor cap by inserting a screwdriver in upper slotted end of cap latches; then press down and turn 90 degrees counterclockwise.
2. Make a mark on distributor base in line with center of rotor. Then carefully note the direction the vacuum unit points in relation to the engine so that the distributor can be replaced in the exact same position after it is serviced. See Figure 68- 28.

If engine is turned over while distributor is out, complete ignition timing procedure must be followed (paragraph 68-19).

3. Remove distributor clamp and lift distributor out of crankcase.
4. Remove rotor from end of distributor shaft by removing two attaching screws and lock washers. Remove ignition point shield.
5. Remove contact point set and condenser as described in paragraph 68-18.
6. Remove cam lubricator wick.
7. Remove two screws holding vacuum advance unit to housing. Remove advance unit.
8. Remove "O" ring seal from shaft housing.

B. Inspection of Distributor Parts

1. Wash the distributor assembly in clean solvent, holding housing horizontal to avoid getting cleaning solvent into the lubricant reservoir. Dry parts thoroughly.
2. *Cap*. Wipe out distributor cap with a clean cloth and inspect it for chips, cracks and carbonized paths which would allow high tension leakage to ground. Such defects require replacement of cap. Clean loose corrosion from surfaces of terminal segments inside the cap. *Do not use emery cloth or sand paper*. If segments are deeply grooved, the cap should be replaced. Pull cables from terminal sockets and inspect sockets for corrosion. Clean sockets, using a stiff wire brush to loosen corrosion.
3. *Rotor*. If rotor is cracked, spring contact is badly worn, or rotor tip is badly burned, rotor must be replaced.
4. *Condenser*. Inspect condenser and primary leads for

loose or frayed terminal connections. Check condenser in a reliable condenser tester as described in paragraph 68-15.

5. *Vacuum Advance Unit.* Inspect rod end for excessive wear. Push rod into unit as far as possible, hold finger tightly over nipple and then release rod. After about 15 seconds, release finger from hole and notice if air is drawn in. If not, diaphragm is leaking and unit must be replaced.

6. *Contact Points.* Carefully examine the mating surfaces of the contact points, noting whether they are flat and making good contact, or whether they are blackened, pitted, burned, or worn excessively. Contact points which have been in service for some time will appear dull and gray. This condition is normal and such points should not be replaced.

Contact points which are blackened or only slightly burned or pitted may be cleaned with a thin contact stone or a clean fine-cut contact file. Remove high spots only; it is not necessary to remove all buildup or pit.

CAUTION: *Do not use emery cloth or sandpaper to clean contact points because particles of these materials usually embed in contact surfaces and cause points to burn.*

Excessively burned, pitted or worn contact points cannot be cleaned up and aligned satisfactorily; therefore, they must be replaced to insure satisfactory ignition.

If contact points are excessively burned, pitted, or blackened it is advisable to check for cause and make the necessary correction so that new points will give satisfactory service. Burned or pitted points may be caused by:

(a) Ignition coil resistance wire not properly connected into circuit. With ignition on and engine not running, voltage at the coil positive terminal should be 5 to 5.5 volts.

(b) Defective condenser. Test the condenser (paragraph 68-15).

(c) Insufficient contact point opening. Adjust contact point dwell as described in paragraph 68-18 (c).

(d) Vapors getting into the distributor and depositing on contact surfaces of points. This causes arcing and rapid burning of contact points. Oil vapor entering distributor usually produces a smudgy line under the points.

(e) High voltage, or any other condition in electrical system causing excessive current flow

through contact points. This results in a blue scale forming on point surfaces. Check condenser for high series resistance (paragraph 68-15). Check voltage regulator (paragraph 68-26).

(f) Radio capacitor connected to distributor terminal. This will cause excessive pitting of contact points. Capacitor should be connected to the positive (battery) terminal of coil.

7. If any remaining parts are defective, the distributor must be completely disassembled to replace them. Before disassembling distributor further, inspect parts as follows:

(a) *Centrifugal Advance.* Inspect for excessive wear between centrifugal weights and advance cam, or pivot pins. Turn weight base plate in a clockwise direction until weights are fully extended, then release and allow springs to return weights to retard position. Repeat several times. Springs should return weights to stop without sticking and there should be no excess free movement in the retard position.

(b) *Cam and Weight Base Plate.* Inspect cam lobes for scoring or excessive wear. Check weight base plate for bind or excessive looseness on distributor shaft.

(c) *Breaker Plate.* Attempt to rotate plate to check for excess free motion between plate and vacuum advance unit linkage. Check plate for excess looseness on O.D. of upper distributor shaft bushing. Check breaker plate ground lead for poor spot-weld at plate end or for loose or frayed terminal connections.

(d) *Distributor Shaft.* Check for excessive wear between shaft and bushings in housing.

(e) *DRIVEN Gear* Inspect gear for scoring of teeth or excessive wear.

8. To replace any part found to be defective in Step 7, the distributor must be completely disassembled as follows:

(a) Drive out driven gear pin using a hammer and a 1/8" straight punch. See Figure 68-30.

Be careful not to bend distributor shaft or damage gear when driving pin out.

(b) Slide gear off shaft and then pull the shaft, breaker cam, and centrifugal advance mechanism from the housing.

(c) Remove two advance weight springs and weights. Slide the integral weight base plate and breaker cam off the lower end of shaft.

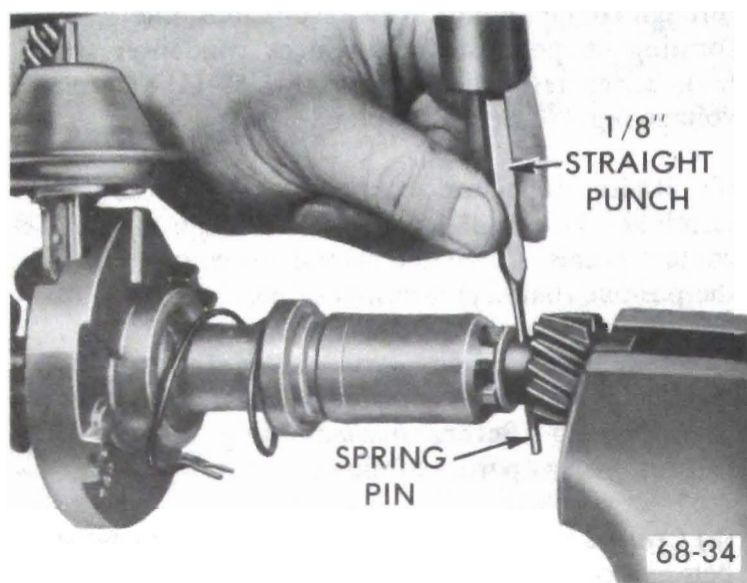

Figure 68-30 Removing Distributor Gear Pin

- (d) Remove retainer from upper bushing and lift breaker plate and felt washer from upper bushing.
- (e) Remove distributor primary lead and grommet from housing.

NOTE: No attempt should be made to replace the shaft bushings in the housing as the housing and bushings are only serviced as an assembly.

C. Assembly and Installation of Distributor

The first five steps apply only if the distributor has been completely disassembled.

1. Install distributor primary lead and rubber grommet. Install vacuum advance unit with ground lead terminal from breaker plate under outer mounting screw and lock washer.
2. Install felt washer over upper bushing and apply a few drops of light oil. Then place breaker plate over upper bushing and vacuum advance link. Install retainer on upper bushing. See Figure 68-31.
3. Slide distributor cam and weight base plate on distributor shaft.
4. Install distributor shaft and breaker cam assembly in housing. Install advance weights and springs.
5. Slide driven gear on shaft. Drive roll pin through gear and shaft. Be careful not to damage gear.
6. Place condenser and bracket over bosses on breaker plate and secure with screw.
7. Place contact point set over boss on breaker plate and secure with two screws and lock washers. Apply one drop of light oil to breaker arm pivot. Then install condenser and primary leads.

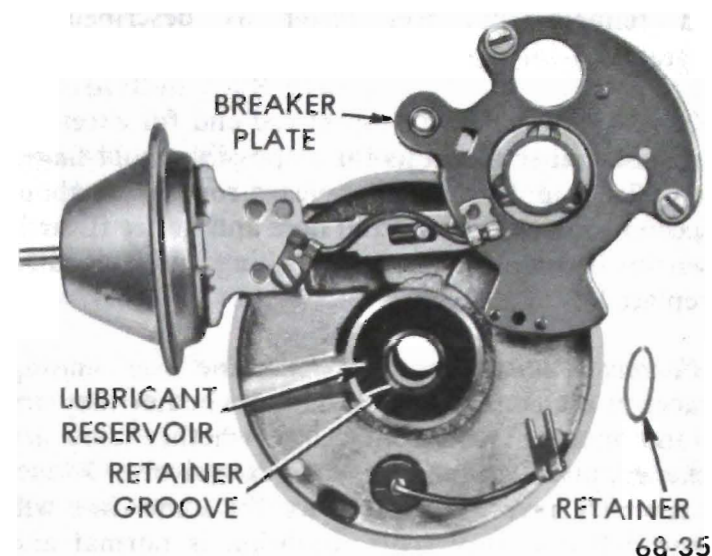

Figure 68-31 Installing Breaker Plate and Retainer

8. Work a small amount of high temperature cam and ball bearing lubricant (available through U.M.S.) into a clean cloth, then hold cloth against distributor cam while turning distributor shaft. Excessive grease may throw off into contact points when hot. Petroleum jelly is not suitable for temperature reached by the cam.
9. Install a new cam lubricator.
10. Make the preliminary contact point adjustment (paragraph 68-18, b).
11. Install ignition point shield. Install rotor and secure with two screws, lock washers, and plain washers. The square and round lugs on the bottom of the rotor must be positioned in the corresponding holes in the weight base plate
12. If a reliable distributor tester is available, check the distributor to make certain that the centrifugal and vacuum advance mechanisms are operating according to the specifications given in paragraph 68-23.
13. Install new "O" ring seal on distributor housing. Insert distributor in engine block so that rotor is pointing to mark made on distributor base, with vacuum advance unit pointing in exact original direction. Connect vacuum pipe to advance unit.
14. Install distributor clamp and bolt with lock washer, leaving bolt just loose enough to permit movement of the distributor with heavy hand pressure.
15. Connect primary wire to distributor side of coil. Install distributor cap.
16. If spark wires were removed, make certain that they are replaced as shown in Figure 68-29. Wires must be pushed all the way down into the distributor cap terminals and onto the spark plugs. Nipples must

be pushed firmly over the terminals and boots over the spark plugs.

17. Start engine and adjust contact point dwell angle (paragraph 68-18, c). Then adjust ignition timing (paragraph 68-19, b). If engine was accidentally turned over while distributor was out, complete ignition timing procedure must be followed (paragraph 68-19, a and b).

68-22 IGNITION SWITCH AND LOCK REPAIRS

A. Ignition Switch Key

If ignition key sticks or feels rough as it is inserted into the lock, examine it for burrs and smooth with a fine cut file. Blow finely powered graphite into lock cylinder, then work key in and out of cylinder a number of times to work graphite into tumblers. *Do not use oil in lock cylinder as this will cause tumblers to stick.*

The ignition switch key has a rectangular shaped head and also operates the door locks. The oval head key operates the glove box lock and trunk lock. The key code number for each key is stamped in the small knock-out insert.

B. Ignition Lock Cylinder Replacement

The ignition lock cylinder cannot be removed until the steering column is partially disassembled to gain access to an internal lock cylinder retainer. The steering wheel, lock plate and turn signal switch assembly must be removed. See Group 90, Section C for detailed instructions.

DIVISION VI

SPECIFICATIONS

68-23 IGNITION SYSTEM SPECIFICATIONS

A. Ignition Coil and Resistor

| | |
|---|------------------------|
| Make | Delco-Remy |
| Coil Number | 1115247 |
| Current Draw, Amperes at 12.6 Volts | |
| Engine Stopped | V-8 3.8 |
| Engine Idling | V-8 2.3 |
| Coil Resistance (Ohms) at 80° F. | |
| Primary | 1.28 to 1.42 |
| Secondary | 7200 to 9500 |
| Resistance Wire | Part of Wiring Harness |
| Resistance, Ohms at 80° F. | 1.80 ±.05 |
| Voltage at Coil (Ignition On and Points Closed) | 5 to 5.5 |

C. Lock Cylinder and Key Information

All 1972 Buicks have new lock cylinders and keys. The new lock cylinder outside dimensions are not changed and there are still six tumblers per lock cylinder. The code consists of a number, a letter and two numbers. The rectangular head key fits the ignition and door locks and the oval head key fits the glove box and trunk locks; however, these new keys have different grooves to that neither can be inserted in any lock cylinder previous to 1972 and so that neither can be inserted in the other type of 1972 lock cylinder.

D. Ignition Key Buzzer

The ignition key operated buzzer is designed to warn the driver that he has left his key in the ignition switch, and his car is therefore subject to theft. The buzzer operates whenever the driver's door is opened with the ignition key left in the switch in either the Off, the Lock, or the Accessory position. It may also operate in the Run or Crank positions with the door open.

The ignition key buzzer circuit is supplied, along with the speed warning buzzer and horns, by a No. 10 red wire from the battery. A combination buzzer and horn relay is used. See Figure 68-33. The circuit passes through the buzzer, then through the ignition switch and to ground through one contact of a double contact left front door jamb switch.

The optional speed warning buzzer uses part of the same circuit, then provides a second path to ground through adjustable contacts in the speedometer head.

B. Spark Plugs

| | 350 Engine | 455 Engine |
|---|-------------------|-------------------|
| Make and Model (Normal Operation) | ACR45TS | ACR45TS |
| Thread and Shell Hex. Sizes | 14 MM, 5/8" | 14MM, 5/8" |
| Terminal Nut Length | 3/8" | 3/8" |
| Gap at Points | .040" | .040" |
| Tightening Torque (Lb.Ft.) | 15 | 15 |

C. Distributor

| | |
|--|------------------------|
| Make | Delco-Remy |
| Drive | From Camshaft |
| Rotation, Top View | Clockwise |
| Firing Order (All V-8 Engines) | 1-8-4-3-6-5-7-2 |
| Contact Point Opening and Dwell Angle V-8 .016", 30° | ° |
| Dwell Variation | 3° Maximum |
| Breaker Arm Spring Tension, Ounces | 19 to 23 |
| Condenser Make and Capacity, Microfarads | Delco-Remy, .18 to .23 |

| | 350 Engine | 455 Engine | 455 Engine Stage I |
|---|-------------------|-------------------|----------------------------------|
| Distributor Number (Less Cap) | 1112109 | 1112110 | 1112016 |
| Vacuum Control Number | 1116210 | 1973440 | 1116210 |
| Timing, Crankshaft Degrees (With Vacuum Disconnected and Engine Idling) | 4° ± 1° | 4° ± 1° | 10° ± 2° (Auto) 8° ± 2° (Man) |
| Centrifugal Advance, Crankshaft Degrees RPM | | | |
| Start Advance, at RPM | 800-1000 | 1000-1200 | 700-1000 |
| Medium Advance, Degrees at RPM | 9-13 at 1800 | 12-16 at 2100 | 9-13 at 1800 |
| Max. Advance, Degrees at RPM | 12-16 at 3000 | 14-18 at 2900 | 20-24 at 4600 |
| Vacuum Advance, Crankshaft Degrees and Inches of Vac. | | | |
| Start Advance, at In. of Vacuum | 6-8 | 6-8 | 6-8 |
| Max. Advance, Degrees at In. of Vacuum | 14-18 at 16 | 14-18 at 13 | 14-18 at 16 |

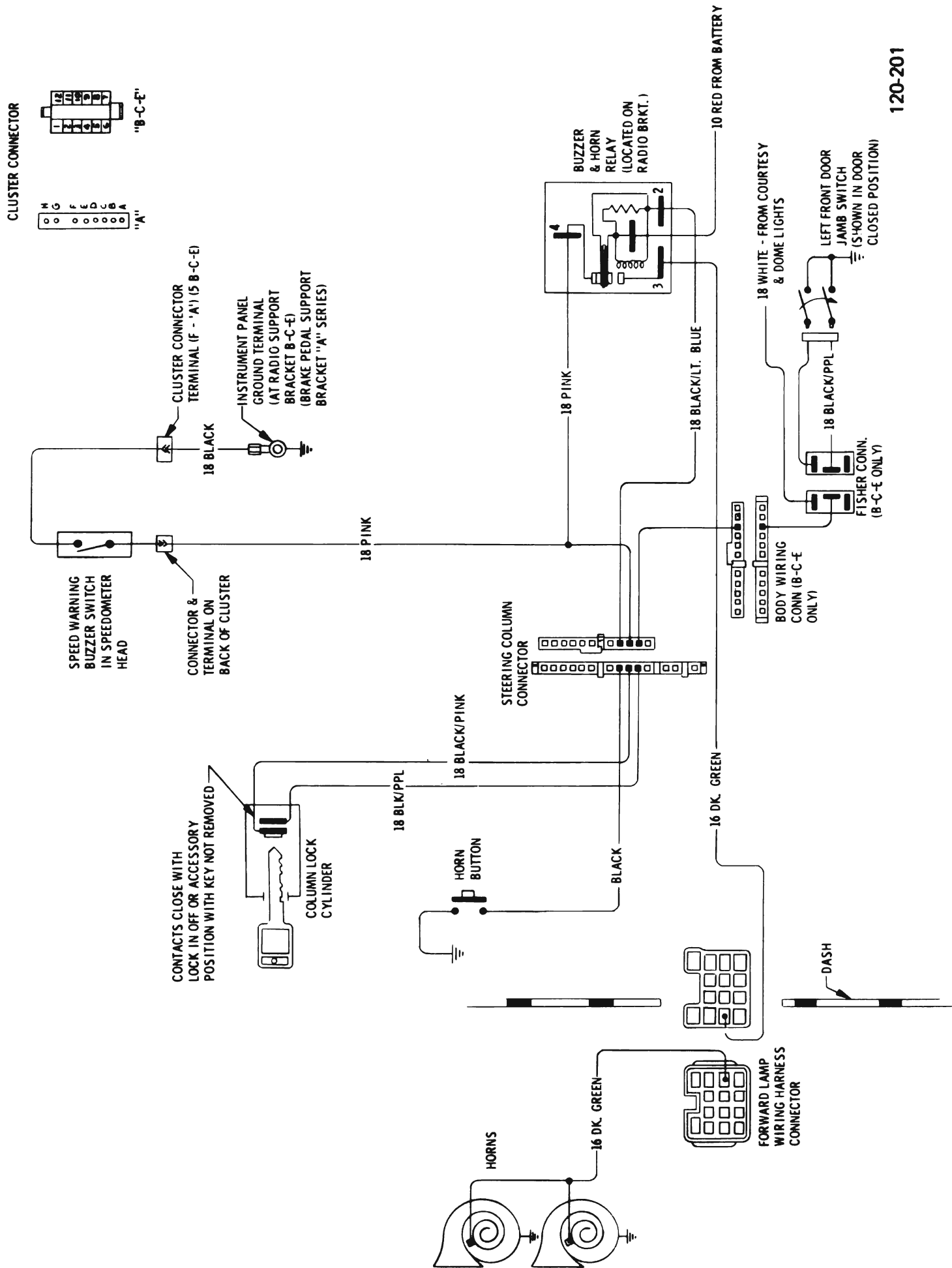

120-201

Figure 68-32 - Buzzer and Horn Relay Wiring

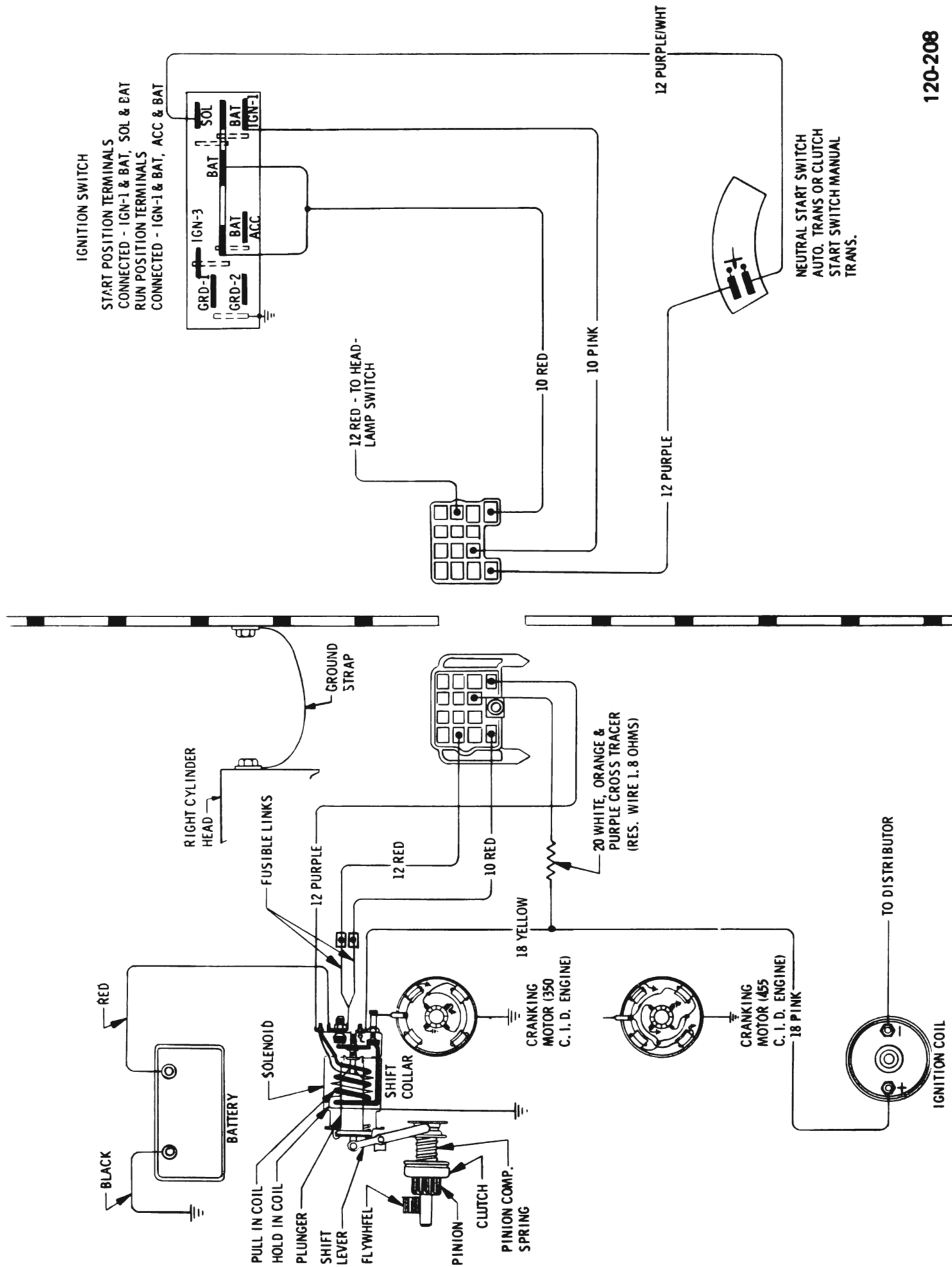

120-208

Figure 68-33 · Ignition and Starter Wiring