

## SECTION A

### MAX-TRAC SYSTEM

### 4L-4N-4R-4P-4U-4V-4Y SERIES

#### CONTENTS

Division	Subject	Page No.
I	<b>TROUBLE DIAGNOSIS:</b> Max-Trac Trouble Diagnosis Chart .....	66-2
II	<b>DESCRIPTION AND OPERATION:</b> General Description .....	66-4
	Operation of Max-Trac System .....	66-6
III	<b>ADJUSTMENTS AND MINOR SERVICE: (Not Applicable)</b>	
IV	<b>REMOVAL AND INSTALLATION:</b> Removal and Installation of Max-Trac Components .....	66-6
V	<b>OVERHAUL AND MAJOR SERVICE: (Not Applicable)</b>	
VI	<b>SPECIFICATIONS: (Not Applicable)</b>	

#### DIVISION I

#### TROUBLE DIAGNOSIS

##### 66-1 MAX-TRAC DIAGNOSIS

The following chart, showing "Conditions", "Possible Causes", and "Corrections" is offered as a diagnostic tool to aid in effecting rapid repairs in the event of a malfunctioning Max-Trac System. It is recommended that for each symptom, the possible causes be evaluated in the order shown on the attached chart.

Condition	Possible Cause	Correction
System inoperative at all speeds.	1. On-off switch set at "Off".	1. Set switch to "On".
	2. Brake lights dead.	2. Repair brake lights.

- |  |  |
|--|--|
| 3. No signal from transmission speed sensor (faulty harness or an open circuit in the sender). | 3. Unplug 6 terminal connectors at controller. Resistance between red and white wires at harness connector should be 1600 to 2400 ohms. If circuit is open, unplug connector at sensor and check resistance across sensor terminals. If open, replace sensor. If 1600 to 2400 ohms, replace the harness. |
|--|--|

- |  |  |
|--|--|
| 4. No signal from front wheel speed sensor (a faulty harness or open circuit in sensor). | 4. Unplug 6 terminal connectors at controller. Resistance between light green and white wires in harness connector should be 1250 to 1750 ohms. If circuit is open, unplug connector at sensor and check resistance at sensor terminals. If open, replace sensor. If 1250 to 1750 ohms, replace the harness. |
|--|--|

- |   |   |
|---|---|
| 5. Low signal from front wheel speed sensor (excessive gap between sensor and speed). | 5. Check and adjust gap between sensor and speed disc at the sensor mounting. Felt spacer should touch the speed disc. If felt spacer is missing, set gap between end of sensor and speed disc at .05 inches. |
|---|---|

- |                       |                            |
|-----------------------|----------------------------|
| 6. Controller faulty. | 6. Replace the controller. |
|-----------------------|----------------------------|

Engine will start but will not run until on-off switch is set at "Off".

- |   |   |
|---|---|
| 1. No battery (positive) electrical supply to controller. | 1. Unplug 3 terminal connectors at controller. With ignition switch "On", battery voltage should be available between the pink wire at the harness connection and ground. If not, repair or replace instrument panel harness. |
|---|---|

- |  |   |
|--|---|
| 2. No ground connection to the controller. | 2. Unplug 6 terminal connectors at controller. The black wire at the controller connector should be grounded. If not, connect controller ground wire to ground. |
|--|---|

- |   |  |
|---|--|
| 3. No connection between controller output and ignition ballast resistor. | 3. Unplug 3 terminal connectors at controller. Resistance between pink/black wire at harness connector and positive terminal of coil should be 1.8 ohms. If open, repair or replace harness. |
|---|--|

- |                       |                            |
|-----------------------|----------------------------|
| 4. Faulty controller. | 4. Replace the controller. |
|-----------------------|----------------------------|

System functions or engine stops during braking.

- |  |  |
|--|--|
| 1. No B (positive) from brake circuit. | 1. Unplug 3 terminal connectors at controller with brakes applied. Battery voltage should be available between white wire and ground. If not, repair or replace I.P. |
|--|--|

		harness.
	2. Brake lights dead.	2. Repair car harness.
	3. No connection from controller to brake switch.	3. Unplug 3 terminal connectors at controller. With the brakes applied, battery voltage should be available between white wire and ground. If not, repair or replace the harness.
	4. Faulty controller.	4. Replace the controller.
System functions properly at high speeds but is inoperative at some speeds greater than 2 mph.	1. Low signal from the undriven wheel speed sensor (excessive gap between sensor and speed).	1. Check and adjust gap between sensor and speed disc at the sensor mounting. Felt spacer should touch the speed disc. If felt spacer is missing, set gap between end of sensor and speed disc at .05 inches.
	2. Faulty controller.	2. Replace the controller.
System functions below 2 mph.	1. Faulty controller.	1. Replace the controller.
System inoperative below 2 mph.	1. This is a normal characteristic of the Max-Trac System.	
System operates when not necessary.	1. Wrong speedo gear.	1. Replace with correct gear.

## DIVISION II

### DESCRIPTION AND OPERATION

#### 66-2 DESCRIPTION

The purpose of the Max-Trac System is to aid the operator in maintaining vehicle directional stability and maneuverability during acceleration and/or cornering. The system accomplishes this purpose by automatically limiting engine power to a value required for maximum acceleration without excessive rear wheel slippage.

Basic system components include the transmission speed sensor, front wheel speed sensor and speed disc, electronic controller, "on-off" switch, and electrical harness. In addition, the system uses the existing ignition switch, brake switch, brake light, and ignition components.

#### 1. Transmission Speed Sensor

This sensor is a mechanically driven electro magnetic device which produces an AC voltage with frequency proportional to the input shaft speed. The sensor is mounted in the transmission at the speedometer cable connection. Its function is to convert the rear wheel speed into an electrical signal at a frequency of 25 Hz/mph. This rear wheel speed signal is transmitted via the electrical harness to the electronic controller.

#### 2. Front Wheel Speed Sensor and Speed Disc

This sensor is an electro-magnetic device which, in conjunction with the rotating speed disc, produces an AC voltage with frequency proportional to the speed of the disc. The speed disc is mounted on the hub of the left front wheel. The sensor is mounted at a predetermined distance from the disc and the gap is adjustable at the sensor mounting. The function of the sensor is to convert the front wheel speed into an electrical signal at a frequency of 6.25 Hz/mph.

This front wheel speed signal is transmitted via the electrical harness to the electronic controller.

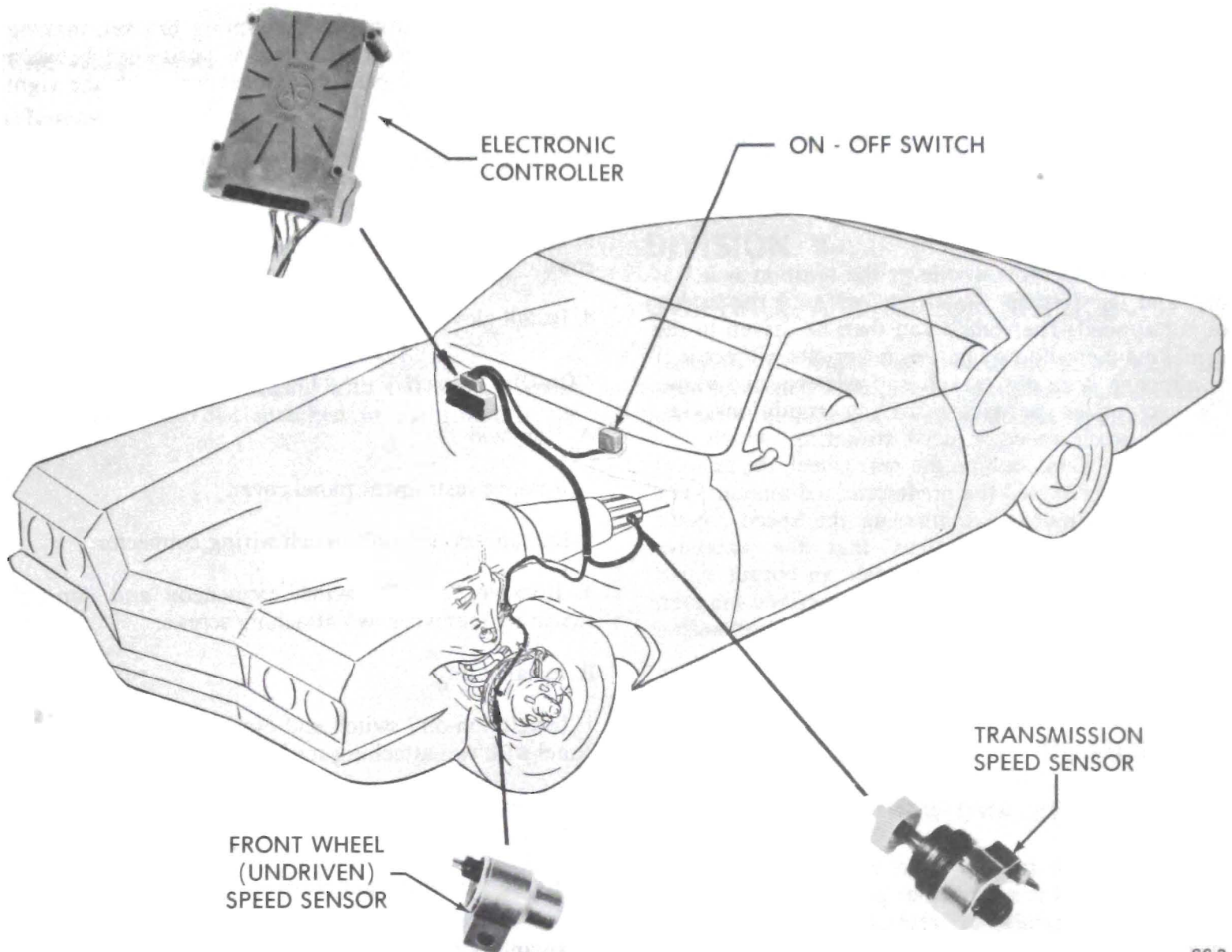

66-3

Figure 66-1 Max-Trac System

### 3. Electronic Controller

The controller is a solid state electronic computer and is mounted in the passenger compartment. It receives the driven and undriven wheel speed signals from the sensors. Its function is to compare the two-speed signals and, when the difference exceeds a predetermined amount, to generate a 30 Hz output signal with a duty cycle proportional to the speed difference. This output signal is transmitted via the electrical harness to the ignition system.

### 4. "On-Off" Switch

The "on-off" switch is located on the vehicle's instrument panel. It allows the operator to make the Max-Trac operation optional. It is recommended that the switch normally be in the "on" position. However, it is desirable to have the system inoperative under certain driving conditions, i.e., rocking the car in

snow. Also, should a malfunction in the system occur, the vehicle may be driven with the switch "off" until repairs are made. In the "off" position, this switch shorts the controller output signal and prevents it from being transmitted to the ignition system.

### 5. Electrical Harness

The harness provides the electrical connection between the sensors, controller, power source, ignition switch, brake switch, and ignition coil.

**NOTE:** Refer to Figure 66-6 for replacing an upper control arm on cars with the Max-Trac option. Two new holes in the control arm for the wiring harness clips must be drilled as shown.

**66-3 OPERATION**

The components of the Max-Trac System are interconnected, as shown in Figure 66-7. The system is not operable whenever the ignition switch is "off" and/or the "on-off" switch is "off" and/or the brakes are applied. When the ignition switch is "on", the vehicle can be driven in the normal manner without Max-Trac operation, regardless of the amount of slippage.

The system is operable whenever the ignition switch is "on" and the "on-off" switch is "on" and the brakes are not applied. The vehicle can then be driven in the normal manner and no ignition interrupts will occur if the slippage does not exceed a predetermined value. However, under particular driving conditions, i.e., excessive acceleration or hard cornering, which reduces the normal load on the rear wheel, the amount of slippage can exceed the predetermined amount. The controller, continuously comparing the speed signals from the sensors, determines that the excessive slippage has occurred and generates an output signal which interrupts the ignition in the prescribed manner, resulting in a power reduction and a corresponding reduction in slippage.

**DIVISION III****ADJUSTMENTS AND MINOR SERVICE**

When the system fails to function properly and the trouble is isolated to a particular portion of the system, the bad part should be replaced by a new and functioning part.

**DIVISION IV****REMOVAL AND INSTALLATION****66-4 REMOVAL AND INSTALLATION OF MAX-TRAC COMPONENTS****Electronic Controller****A. Removal**

1. Remove glove box.
2. Remove controller and mounting bracket attaching screws from cowl.
3. Disconnect wiring harness connectors from controller pigtails and remove controller.
4. Remove controller to mounting bracket attaching screws.

**B. Installation**

1. Assemble controller and mounting bracket, making sure the controller ground wire is positioned between the controller and bracket and secured with the right attaching screw.
2. Attach the controller wire connectors to the harness connectors.
3. Attach controller and mounting bracket assembly to cowl.
4. Install glove box.

**"On-Off" Switch****A. Removal**

1. Remove instrument panel cover.
2. Disconnect "on-off" switch wiring connector.
3. Remove "on-off" switch escutcheon and "on-off" switch by removing two attaching screws.

**B. Installation**

1. Install "on-off" switch and escutcheon in instrument panel with two attaching screws.
2. Connect switch wiring connector to harness connector.
3. Install instrument panel cover.

**Transmission Speed Sensor****A. Removal**

1. Disconnect wire connector from speed sensor terminal.
2. Disconnect speedo cable from speed sensor.
3. Remove speed sensor retainer bolt, retainer, and shim sleeve.
4. Pull speed sensor and driven gear out of transmission and have a container ready to receive transmission oil that will drain out.

**B. Installation**

1. Assemble speedo driven gear onto speed sensor and install with new "O" ring seal into transmission.
2. Install speed sensor retainer, shim sleeve, and bolt.
3. Connect speedo cable to speed sensor.
4. Attach harness connector to speed sensor terminal.

5. Using transmission filling procedures, check transmission fluid level and add as necessary.

### **Front Wheel Sensor**

#### **A. Removal**

1. Remove cable attaching screw from rotor shield.
2. Disconnect wire connector from front wheel sensor.
3. Remove wheel sensor retaining bolt and sensor.

#### **B. Installation**

1. Install wheel speed sensor with felt tip of sensor against the speed disc attached to the rotor. If the

original wheel speed sensor is reinstalled, an air gap of .050" must exist between the tip of the sensor and the speed disc.

2. Connect wire connector to wheel speed sensor terminal.
3. Attach cable retaining clamp to rotor shield.

## **DIVISION V**

### **OVERHAUL AND MAJOR SERVICE**

If any of the major components of this system are found to be defective through diagnosis and checking, they are to be replaced, as they are not repairable.

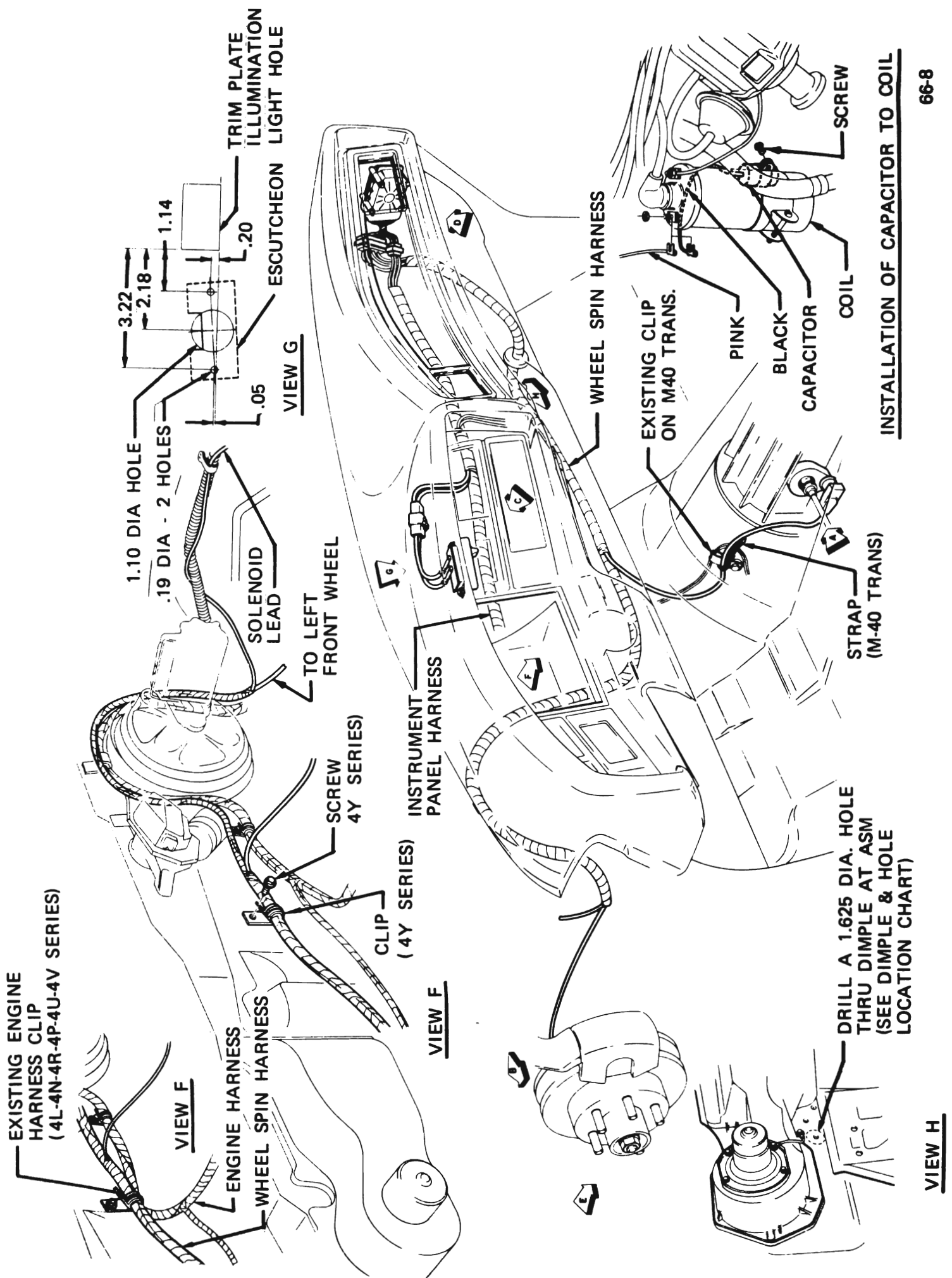

Figure 66-2 Max-Trac Wiring Harness Routing

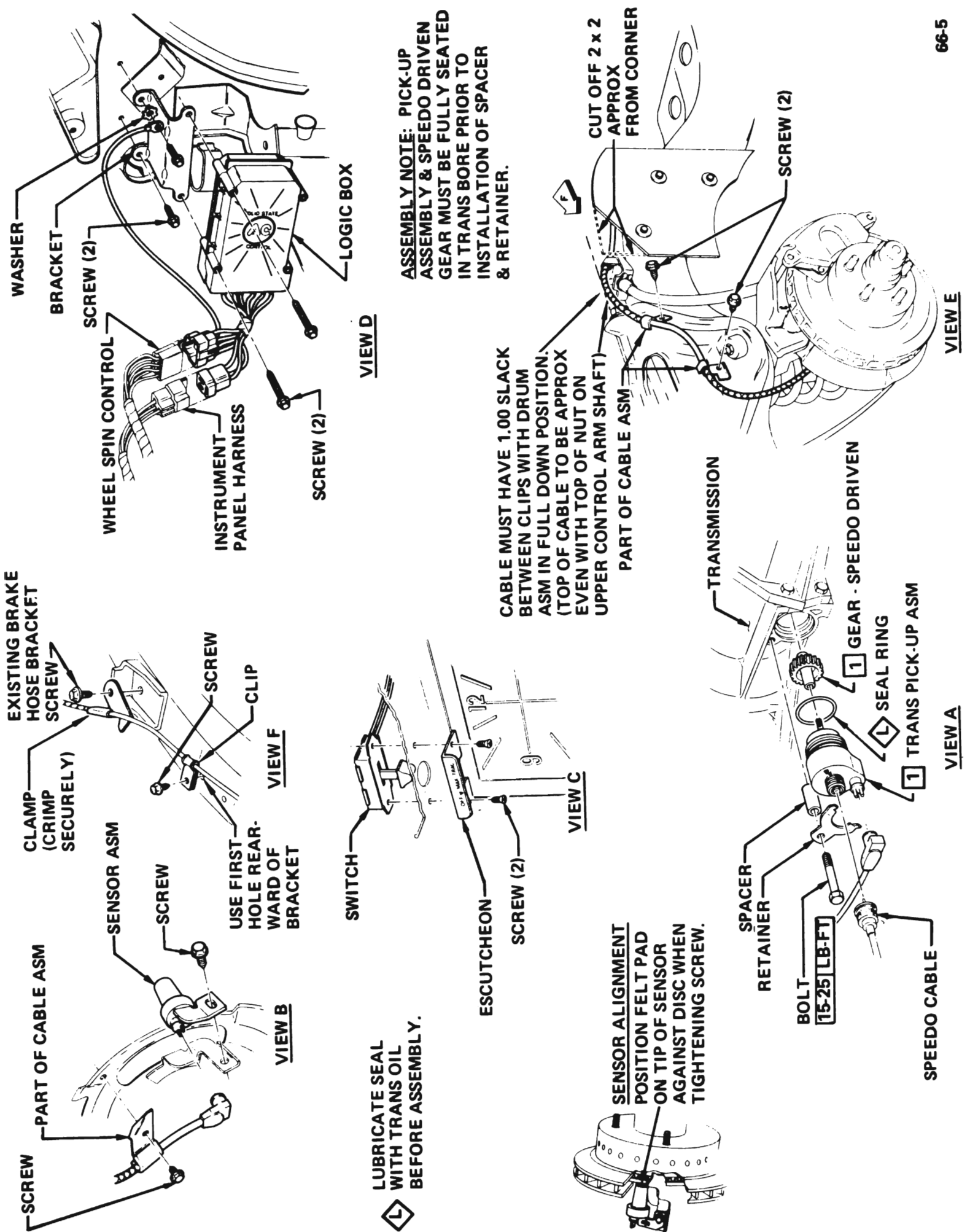

Figure 66-3 Max-Trac Component Installation



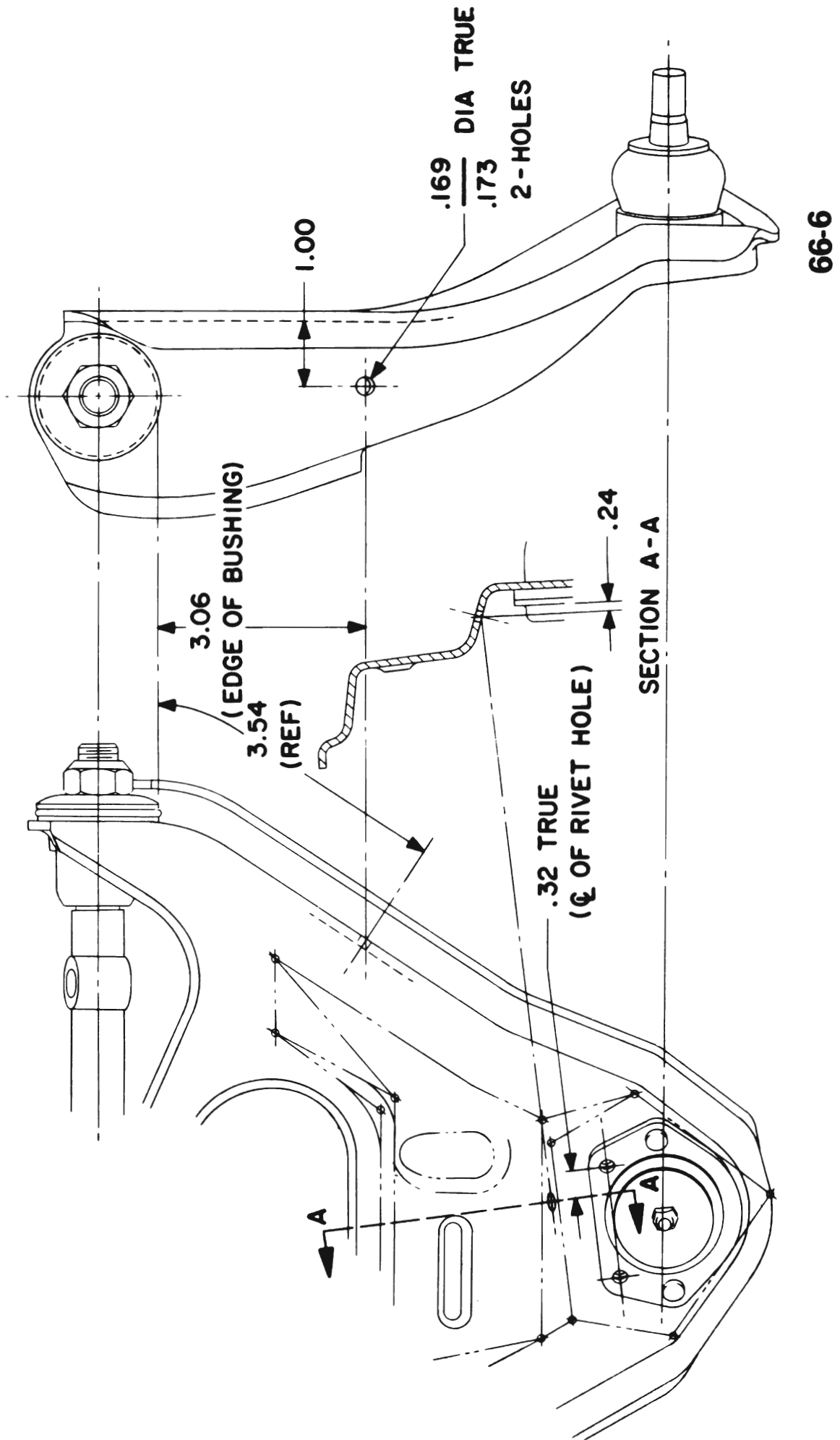

Figure 66-4 Upper Control Arm Drilling Information

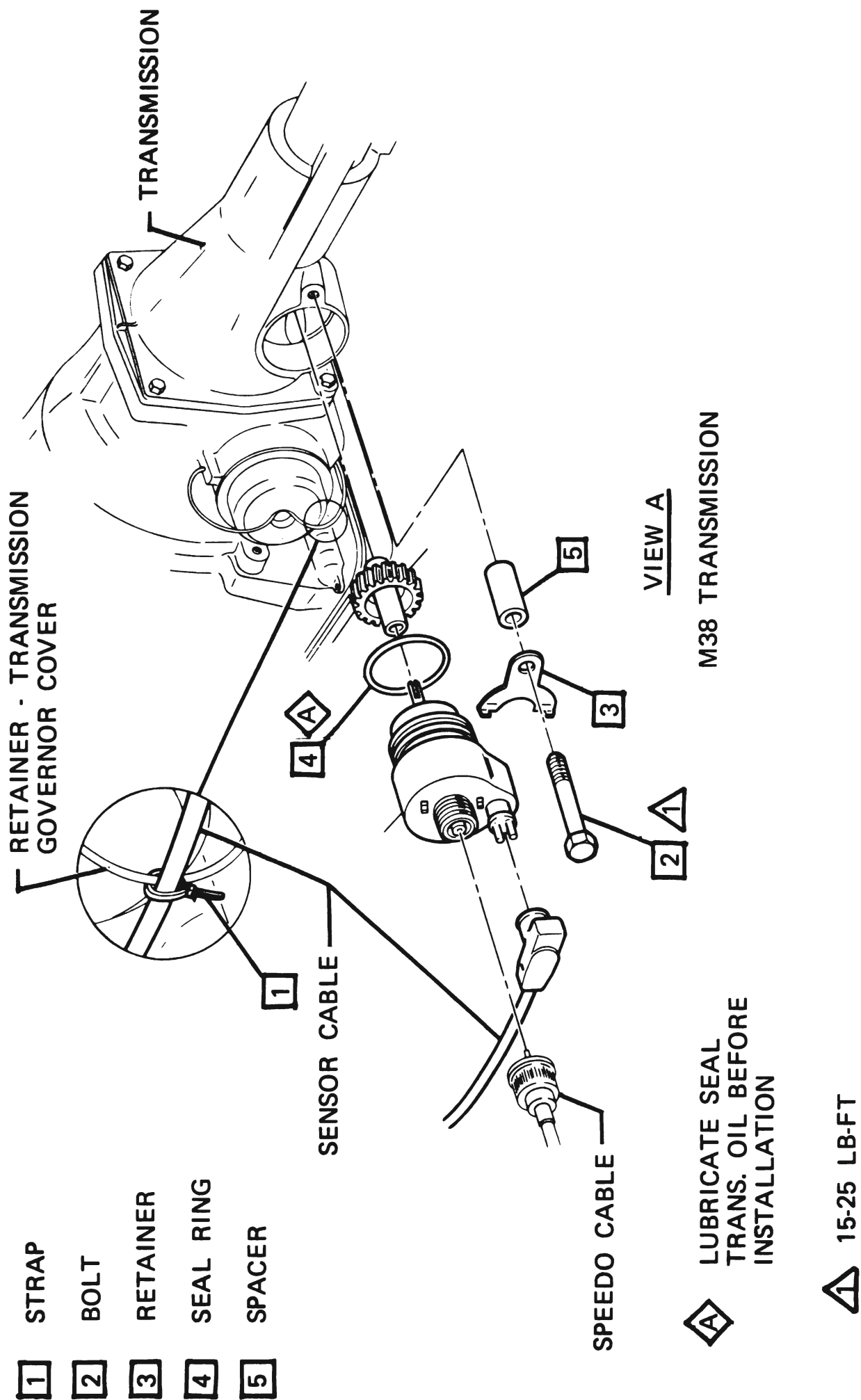

Figure 66-5 Transmission Sensor - 4L-4N-4R-4P Series

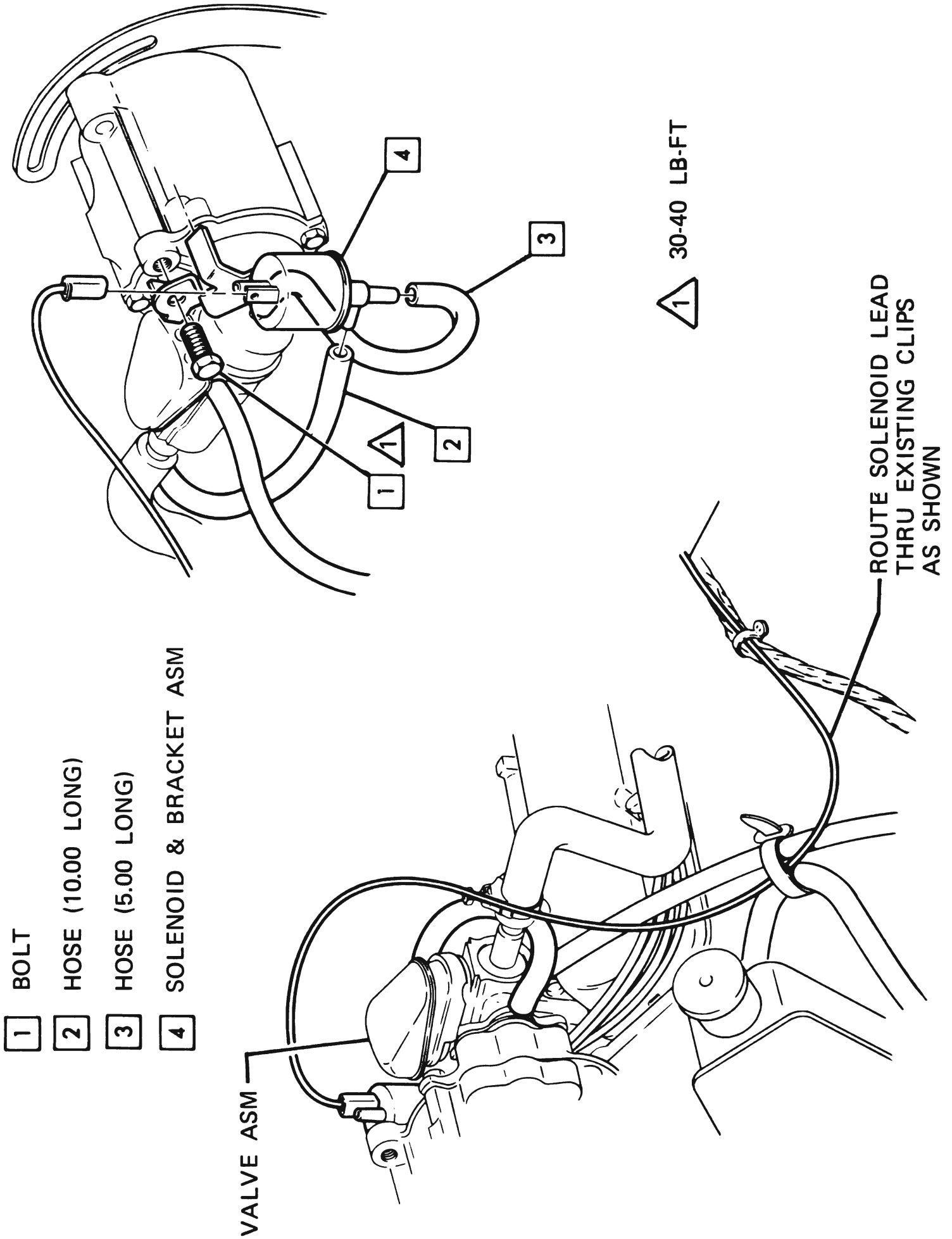
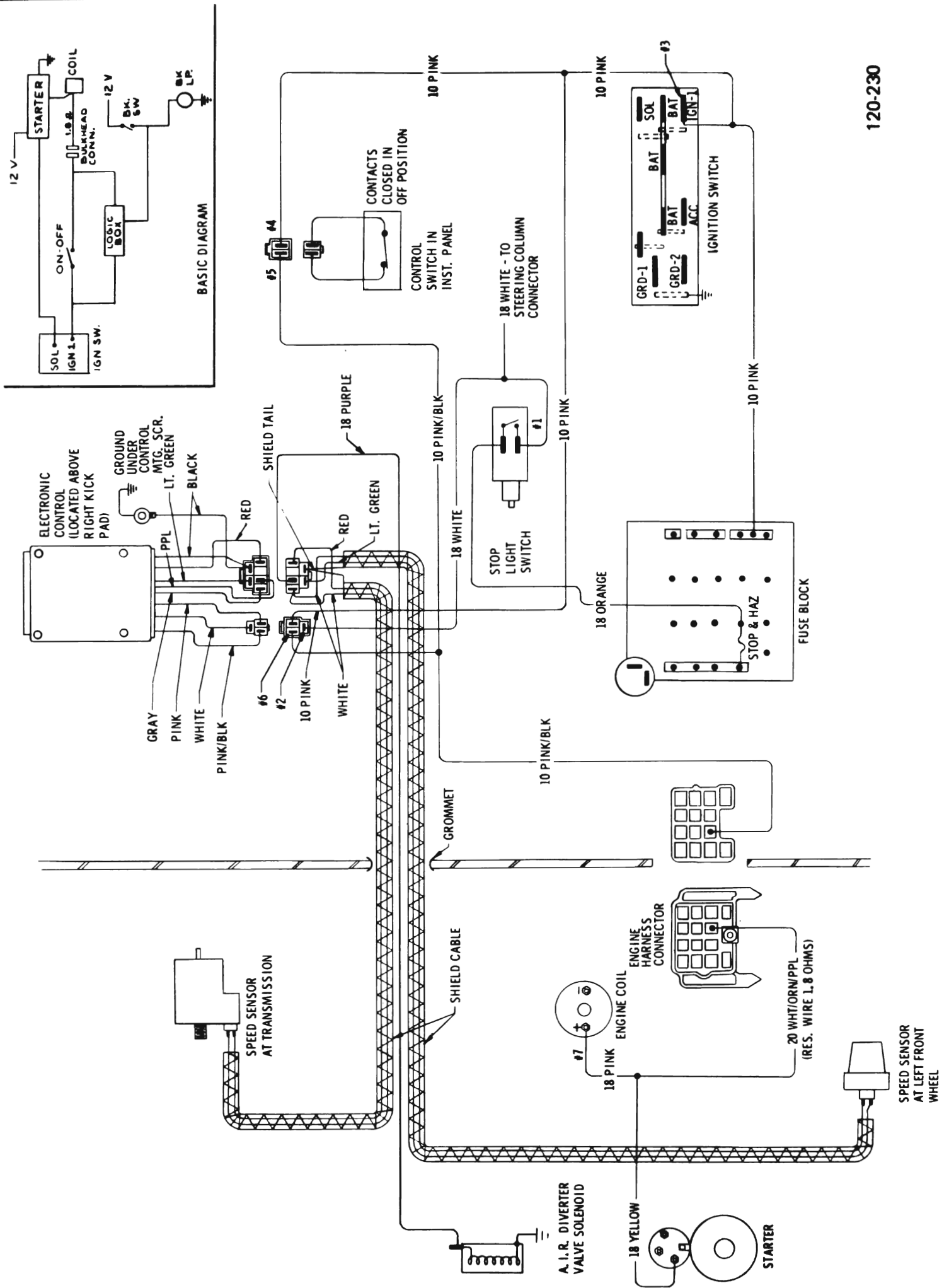

Figure 66-6 Max-Trac Diverter Valve Solenoid



120-230

Figure 66-7 Max-Trac Wiring Diagram