

SECTION A

FUEL SYSTEM GENERAL

ALL SERIES

CONTENTS

Division	Subject	Page No.
I	TROUBLE DIAGNOSIS:	
	Hard Starting	64-2
	Improper Engine Performance	64-3
	Excessive Fuel Consumption	64-4
II	DESCRIPTION AND OPERATION:	
	Description of Engine Fuel System	64-5
III	ADJUSTMENTS AND MINOR SERVICE:	
	Carburetor Idle Speed and Mixture Adjustments	64-5
	Throttle Linkage Adjustments	64-7
	Air Cleaner, Fuel Filter and Vent Valve Service	64-7
IV	REMOVAL AND INSTALLATION: (Not Applicable)	
V	OVERHAUL AND MAJOR SERVICE: (Not Applicable)	
VI	SPECIFICATIONS:	
	Specifications and Adjustments	64-8

DIVISION I

TROUBLE DIAGNOSIS

64-1 HARD STARTING

A. Improper Starting Technique

Hard starting may be due to improper starting technique. If possible, observe the owner's method of starting; if not correct, suggest that he use the following procedure.

1. *Automatic Transmission.* Place control lever in "P"

or "N" position. Starter cannot be operated in any other position.

Manual Transmission. Place control lever in neutral and depress clutch pedal to floor. Starter cannot be operated unless clutch pedal is depressed.

2. *Engine Cold.* Depress accelerator pedal to floor once, release and remove foot completely from accelerator pedal. This presets the automatic choke and throttle.

Engine Warm Hold accelerator pedal about 1/3 down.

3. Turn ignition switch to "START" and release when engine starts. As soon as the engine is running

smoothly, depress the accelerator pedal to slow the engine down to warm up speed.

If the engine is warm, but fails to restart promptly, there may be an excess of fuel or "flooding" (this is more likely to occur at low temperatures).

Flooding. Hold the accelerator pedal to the floor (fully depressed) while cranking the engine; this opens the choke to "unload" any excess fuel. When the engine fires, do not immediately release the accelerator pedal, but hold it down until the engine speed increases.

If the engine has not been started for several days, most of the fuel will have evaporated from the carburetor. Pumping the accelerator pedal, while cranking, will pump fuel directly into the engine which will hasten the start.

B. Improper Ignition

Before attempting any correction in fuel system make certain that the battery and ignition system are in proper condition. See paragraph 120-2 and 68-22.

C. Improper Adjustment of Fast Idle Cam or Choke Unloader

An incorrectly-adjusted fast idle cam may not provide sufficient throttle opening and stalling will result.

If the choke unloader goes into action too soon it may cause hard starting when engine is cold. If choke unloader goes into action too late or not at all, it may cause hard starting when engine is flooded.

D. No Fuel at Carburetor

Fuel may not be delivered to carburetor due to empty gasoline tank or stoppages in filters, strainers or feed hoses, or inoperative fuel pump. Test fuel supply as described in paragraph 64-9.

E. Improper Carburetor Adjustment

A high fuel level in float bowl will cause flooding and consequent hard starting. Adjust carburetor (par. 64-5).

F. Low Grade Gasoline

Low grade gasoline is usually insufficiently volatile to provide easy starting in cold weather even though it may perform reasonably well after the engine is started and warmed up. A change to high grade gasoline is the only remedy.

G. Volatile Gasoline

In some parts of the country, gasolines are marketed which are very volatile and generally advertised as "easy starting gasolines." Some of these fuels are so volatile they boil (commonly referred to as "percolation") in a carburetor bowl which is only normally warm, especially when the engine is shut off following a run. This overloads the manifold, resulting in an over rich mixture which may cause "delayed" starting.

64-2 IMPROPER ENGINE PERFORMANCE

A. Engine Idles Too Fast

A cold engine should operate on fast idle for two to five minutes depending on air temperature. At 32 degrees F. the fast idle cam should move to slow idle position in approximately 1/2 to 1 1/4 mile of driving. At high temperatures it should move to slow idle position in a correspondingly shorter distance.

If the engine operates too long on the fast idle cam, check the choke coil ro setting and the fast idle d cam adjustment.

If the engine idles faster than the specified idle speed when off the fast idle cam, check throttle linkage for binding or weak return spring and adjust throttle stop screw (par. 64-6). This trouble can also be caused by a sticking choke.

B. Improper Idle and Low Speed Performance

Rough idling and tendency to stall may be caused by idling speed set below the specified idle speed.

Rough idling, poor performance, and back firing at low speeds frequently originates in improper ignition. Check ignition system.

High fuel pump pressure will cause rough idling and poor low speed performance (par. 64-10).

An intake manifold air leak will cause rough idling and poor low speed performance. A manifold air leak produces a low, erratic reading on a vacuum gage connected to the intake manifold.

Check for leaks at all pipe connections and check manifold joints with gasoline.

When rough idling and poor low speed performance cannot be corrected by checks of carburetion and ignition mentioned above, check cylinder compression.

Improper performance which is most noticeable at low speeds may be caused by sticking valves.

Sticking valves may be caused by the use of low grade fuel or fuel that has been in storage too long. *When a car is stored for any length of time, fuel should be*

drained from the tank, feed hoses, fuel pump, and carburetor in order to avoid gum formation.

C. Improper High-Speed Operation

Roughness or poor performance above 22 MPH indicates faulty ignition (par. 68-13) or improper settings in the high speed circuit of carburetor. Surging at high speed may be caused by low fuel pump pressure (par. 64-10).

Surging at 75 to 80 MPH constant speed indicates that the power jet is stopped up or the vacuum piston is sticking.

If there is lack of power at top speed, check throttle linkage to insure full throttle valve opening (par. 64-6).

D. Excessive Detonation or Spark Knock

Light detonation may occur when operating a synchromesh car in high gear with full throttle between 14 and 22 MPH, or when operating an automatic transmission car in Drive with full throttle at low speed even when ignition timing is correct and proper fuel is used. This light detonation is normal and no attempt should be made to eliminate it by retarding the ignition timing, which would reduce economy and over-all performance.

Heavy detonation may be caused by improper ignition timing (par. 68-19), improper grade of fuel, or by an accumulation of carbon in combustion chambers.

Heavy detonation is injurious to any automotive engine. A car driven continuously under conditions and fuels which produce heavy detonation will overheat and lose power, with the possibility of damage to pistons and bearings.

64-3 EXCESSIVE FUEL CONSUMPTION

Complaints of excessive fuel consumption require a careful investigation of owner driving habits and operating conditions as well as the mechanical conditions of the engine and fuel system; otherwise, much useless work may be done in an attempt to increase fuel economy.

Driving habits which seriously affect fuel economy are: high speed driving, frequent and rapid acceleration, driving too long in a low speed range when getting under way, excessive idling while standing.

Operating conditions which adversely affect fuel economy are: excessive acceleration, frequent starts and stops, congested traffic, poor roads, hills and mountains, high winds, low tire pressures.

High speed is the greatest contributor to low gas

mileage. Air resistance increases as the square of the speed. For instance, a car going sixty miles an hour must overcome air resistance four times as great as when going thirty miles an hour. At eighty miles an hour the resistance is over seven times as great as when going thirty miles an hour.

Over seventy-five per cent of the power required to drive a car eighty miles an hour is used in overcoming air resistance, while at thirty miles an hour only thirty per cent of the power required is used to overcome air resistance.

Gas mileage records made by car owners never give a true picture of the efficiency of the engine fuel system since they include the effects of driving habits and operating conditions. Because of the wide variation in these conditions, it is impossible to give average mileage figures for cars in general use; therefore, any investigation of a mileage complaint must be based on an accurate measurement of gasoline consumption per mile under proper test conditions.

A. Gasoline Mileage Test

A gas mileage test should be made with an accurate measuring device on a reasonably level road, at fixed speeds, without acceleration or deceleration. Test runs should be made in both directions over the same stretch of road to average the effect of grades and wind resistance. Test runs made at 30-50 and 70 MPH will indicate the approximate efficiency of the low speed, high speed, and power systems of the carburetor and show whether fuel consumption is actually abnormal. If a mileage test indicates that the fuel consumption is above normal, check the following items.

1. *Fuel Leaks.* Check all gasoline hose connections, fuel pump, gasoline filter, and carburetor bowl gasket.
2. *Tires.* Check for low tire pressures.
3. *Brakes.* Check for dragging brakes.
4. *Ignition Timing--Spark Plugs.* Late ignition timing causes loss of power and increases fuel consumption. Dirty or worn out spark plugs are wasteful of fuel.
5. *Low Grade Gasoline.* Use of gasoline of such low grade that ignition timing must be retarded to avoid excessive detonation will give very poor fuel economy.
6. *Air Cleaner.* Check for dirty or clogged cleaner element (par. 64-7).
7. *Automatic Choke.* Check for sticking choke valve and improper setting of choke coil rod.
8. *Valves.* Check for sticking valves.

9. **Fuel Pump.** Check for excessive fuel pump pressure (par. 64-9).

10. **Carburetor Adjustment.** Check idle speed adjustment (par. 64-5).

For all other adjustments to high speed and power systems, the carburetors must be removed and disassembled.

B. Changing Carburetor Calibrations

Under no circumstances should the jet sizes, metering rods, and other calibrations of a carburetor be changed from factory specifications. The calibrations given in the calibrations paragraph must be adhered to unless these are later changed by a bulletin issued from the Buick Service Department.

DIVISION II

DESCRIPTION AND OPERATION

64-4 DESCRIPTION OF ENGINE FUEL SYSTEM

A. Fuel Filter

All engines have a pleated paper fuel filter located in the carburetor inlet.

All cars have a woven plastic fuel filter in the fuel tank on the lower end of the pick-up pipe.

B. Fuel Pump

The fuel pump is mounted at the lower left side of the timing chain cover. It is actuated by an eccentric mounted on the front end of the camshaft. The pump is inverted, thereby placing it in a lower, cooler location. It has a built-in air pocket to dampen out pulsations in fuel pressure. The construction and operation of the fuel pump are described in Section 64-B.

All V-8 air conditioner equipped cars have a special fuel pump which has a metering outlet for a vapor return system. Any vapor which forms is returned to the fuel tank along with hot fuel through a separate line alongside the supply line. This greatly reduces any possibility of vapor lock by keeping cool fuel from the tank constantly circulating through the fuel pump. All 455 engines have the vapor return system regardless of whether or not the car is equipped with an air conditioner.

C. Air Cleaner and Intake Silencer

All engines are equipped with oiled paper element air

cleaners as standard equipment; the optional heavy duty air cleaner is identical except that it contains a two layer element of oiled polyurethane and oiled paper. The air cleaner removes abrasive dust and dirt from the air before it enters the engine through the carburetor. The intake silencer reduces to a very low level the roaring noise made by the air as it is drawn through the intake system. The cleaner and silencer also functions as a flame arrester in event of "backfire" through the intake system.

There are four standard air cleaner and silencer assemblies: one for 350 two-barrel carburetor engines, one for standard four-barrel carburetor engines, one for G.S. 350-455 engines and one for G.S. Riviera engines.

Before installing an air cleaner, always make sure the air cleaner gasket is in good condition and is properly located on the carburetor flange. It is important to securely tighten the wing nut *by hand* to make sure the air cleaner remains stationary and to make sure the gasket seals properly.

For normal operating conditions, the element should be replaced every 24,000 miles (more often under dusty operating conditions).

D. Throttle Linkage

All 1972 Buicks have a flexible cable-type throttle linkage that is not adjustable.

On all automatic transmission cars, a transmission downshift mechanism is mounted inside the car just above the accelerator pedal. When the accelerator pedal is moved to wide open throttle position (fully depressed), the mechanism operates, causing the transmission to "downshift". See Figures 64-7 thru 10.

DIVISION III

ADJUSTMENTS AND MINOR SERVICE

64-5 CARBURETOR IDLE SPEED AND MIXTURE ADJUSTMENTS

Idle Mixture: Correct mixtures for emission compliance and idle quality are pre-set by the manufacturer. All 1972 Buick carburetors are equipped with mixture limiters to maintain this adjustment (plastic caps installed over mixture screw heads). These mixtures should not be altered under normal circumstances. In the few exceptional cases, overhaul or rework (new throttle bodies, bowls, jets, etc.), where idle mixture requires readjusting, the following procedures must be carefully adhered to. Whenever idle mixtures are altered, a *Red Service Cap* must be installed to denote

a change has been made and the proper procedures have been followed for emission compliance.

Carburetor adjustments should not be attempted until it is known that engine ignition and compression are in good order. Any attempt to adjust or alter the carburetor to compensate for faulty conditions elsewhere will result in high exhaust emissions and poor overall performance.

Idle speed and mixture adjustments cannot be made satisfactorily with an abnormally hot engine. On any engine having a thermo vacuum switch, it is particularly important that idle adjustments be made at normal temperature so that these valves will be in normal position.

The air cleaner must be left in place during engine warm-up and while making idle speed and mixture adjustments. The positive crankcase ventilator system should also be in good operating condition when making carburetor adjustments. Either of these items noticeably affects the air-fuel ratio at idle.

Any car which is equipped with an Automatic Level Control has a vacuum regulator valve which shuts off all vacuum to the air compressor during engine idle, thereby preventing compressor from operating and upsetting engine idle. Feel compressor with hand; if it is operating, this malfunction must be fixed before adjusting engine idle. See Group 40, Section B.

A. Idle Speed and Mixture Adjustment

Carburetor speed screws are pre-adjusted to obtain specified engine RPM after the engine is broken in (approximately 500 miles). New engines are expected to idle as much as 100 RPM slower. If the idle speed is adjusted to specifications at new car delivery, care should be taken to reset it after a few hundred miles to prevent dieseling and improve idle quality.

1. Connect an accurate tachometer to engine.
2. Start engine and run it at fast idle until upper radiator inlet is hot and choke valve is wide open.
3. Disconnect and plug distributor vacuum line, start engine, and set ignition timing.
4. Set transmission in "Drive" for automatic transmissions and "Neutral" for manual transmissions.
5. Open throttle sufficiently to allow solenoid to extend and contact the throttle lever pad in the idle position.
6. Adjust solenoid set screw to obtain specified RPM. Reposition solenoid bracket if additional movement is required.

7. Disconnect solenoid wire to disengage solenoid.
8. Adjust carburetor idle screw to obtain specified RPM.
9. Reconnect solenoid wire.
10. Adjust idle mixture needles, one at a time, to obtain highest tachometer reading. After highest reading is reached using mixture needles, readjust throttle stop screw and mixture screws, as required, to obtain 50 RPM faster than specified idle. Next, turn each mixture needle in (lean as required to reduce engine speed 25 RPM). This reduces idle speed to the recommended RPM.
11. Adjust fast idle speed on all four-barrel carburetors. Fast idle must be adjusted after slow (curb) idle speed and mixture have been adjusted. Automatic transmission cars are adjusted on the low step of the fast idle cam in "Drive" to 700 RPM. Manual transmission cars are adjusted on the low cam step to 820 RPM for 350 engines and 920 RPM for 455 engines.
12. Connect distributor vacuum hose.
13. Install "red" service idle needle limiter caps on mixture screws.

B. Idle Control Solenoid Adjustment

All 1972 Buick engines are equipped with an idle control solenoid. The solenoid is energized with the ignition switch in the "On" or "Run" positions and deenergized in the "Off" position.

Adjust solenoid with transmission in "Drive" for automatic transmissions and "Neutral" for manual transmissions.

All adjustments are to be made with engine at normal operating temperature, choke open, air cleaner on and air conditioning off and plug disconnected vacuum fittings.

1. Disconnect hose from air cleaner to vapor canister.
2. Disconnect distributor vacuum hose. Plug hose to carburetor.
3. Set dwell and timing.
4. Open throttle sufficiently to allow solenoid to extend and contact the throttle lever pad in idle position.
5. Adjust solenoid set screw to obtain specified RPM. Reposition the solenoid mounting bracket if additional movement is required.
6. Disconnect solenoid wire to disengage solenoid.

7. Adjust carburetor idle screw to obtain specified RPM.
8. Reconnect solenoid wire.
9. On all four-barrel carburetors, set fast idle to specified RPM.
10. Reconnect distributor and canister hoses.

64-6 THROTTLE LINKAGE ADJUSTMENTS

Throttle Linkage Check

All 1972 Buicks have a flexible cable-type throttle linkage that is not adjustable. The following check is for proper operation of the throttle cable.

1. Remove air cleaner.
2. Check throttle linkage for proper lubrication.
3. Make sure that linkage is free in all positions and that nothing touches or interferes with the linkage (inside and outside of car). Throttle cable must be routed correctly and free of any kinks or damage.
4. Hold choke open and make sure that return spring fully closes throttle, even though throttle is released very slowly.

64-7 AIR CLEANER AND FUEL FILTER SERVICE

A. Air Cleaner Service

An air cleaner with a dirty element will not properly remove dirt from the air and the dirt entering the engine will cause abnormal formation of carbon, sticking valves, and wear of piston rings and cylinder bores.

Regular replacement of the element at 24,000 mile intervals (or more frequently in dusty territory) is necessary to prevent excessive engine wear.

B. Fuel Filter - All Engines

All engine fuel filters are located in the carburetor fuel inlet. See Figure 64-1. These fuel filter elements are of pleated paper. Elements are placed in the inlet hole with the cupped end outward. A spring holds the

element outward, sealing it by compressing a gasket surface against the inlet fitting. If the element should ever become plugged, pump pressure is sufficient to depress the spring slightly so that some fuel by-passes the element. Thus, a plugged element, instead of causing a car stoppage on the road, allows the engine to continue running on unfiltered fuel. However, the spring pressure is designed to allow only enough fuel to by-pass to let the car run 50 to 60 MPH at a constant speed, or to cut-out at a much lower speed with heavy acceleration. If surging is encountered in the 50 to 60 MPH range, try several hard accelerations; if the engine also runs out of fuel during acceleration, the problem is insufficient fuel, and the most likely reason is a plugged filter. If the owner has "put-up" with this trouble for some time, there is probably dirt in the carburetor due to usage of unfiltered fuel and also due to "dumping" of dirt from the plugged filter element.

The carburetor inlet fuel filter should be replaced every 12,000 miles.

After assembling any filter element in the carburetor, always start the engine and check for leaks in the fuel line and fittings before installing the air cleaner.

C. Other Filters or Strainers

A woven plastic filter is located on the lower end of the fuel pickup pipe in the gas tank. This filter prevents dirt from entering the fuel line and also stops water unless the filter becomes completely submerged in water. This filter is self cleaning and normally requires no maintenance. Fuel stoppage at this point indicates that the gas tank contains an abnormal amount of sediment or water; the tank should therefore be removed and thoroughly cleaned.

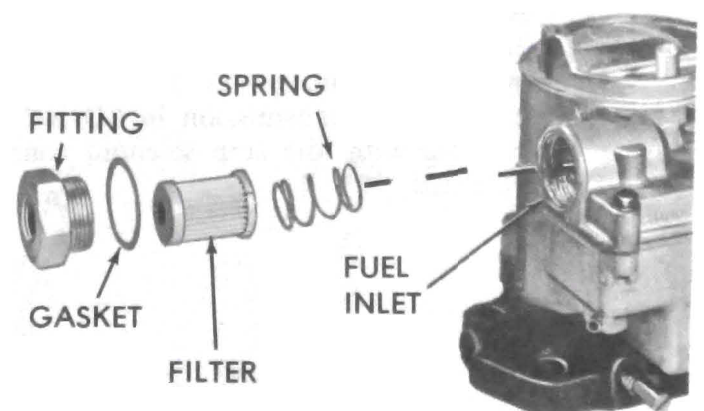

Figure 64-1 - Fuel Filter Parts

DIVISION VI

SPECIFICATIONS

64-8 SPECIFICATIONS

Gasoline Tank Capacity (Approximately)	
Series 4D-4F-4G-4H	20 Gal.
Series 4L-4N-4R-4P-4U-4V	25 Gal.
Series 4Y	25 Gal.
Gasoline Gauge, Make and Type	A.C. Electric
Fuel Pump, Make	A.C.
Fuel Pump, Type and Location	Mechanical, Left Front Engine
Fuel Pump Pressure - At Carb. Level	
350 Engine	3 Lbs.Min.
455 Engine	4-1/2 Lbs.Min.
Fuel Pump Volume	1 Pt. in 30 Seconds or Less
Fuel Filter in Carb. Inlet, Make and Type	
2-Barrel Carb.	A.C., 1 In. Paper, GF-427
4-Barrel Carb.	A.C., 2 In. Paper, GF-441
Fuel Filter, In Gas Tank	Woven Plastic
Carburetor, Make and Type	Rochester, Remote Choke Coil
Air Cleaner, Make and Material	A.C., Oiled Paper Element
Air Cleaner Element, Type - Standard	
G.S. Engines	A212CW
All Other Engines	A329C
Air Cleaner Element, Type - Heavy Duty	
G.S. Engines	A279C
All Other Engines	A368C
Intake Manifold Heat, Type	Exhaust Crossover

Engine and Transmission	(Idle Speed)**		Fast Idle Speed*
	Idle Stop		
	Solenoid Connected	Solenoid Disconnected	
350 Cu.In. Manual	800	600	820
350 Cu.In. Automatic	650	500	700
455 Cu.In. Manual	900	600	920
455 Cu.In. Automatic	650	500	700
455 Stage I Manual	900	600	920
455 Stage I Automatic	650	500	700

*On low step of cam.

**With automatic transmission in "Drive" (manual transmission in "Neutral"), first set solenoid with idle stop solenoid connected, then check idle speed with solenoid disconnected.

- A** (1) THROTTLE CABLE MUST BE INSTALLED IN THE BODY PRIOR TO ASSEMBLY TO THE ENGINE
- (2) THROTTLE CABLE MUST NOT BE SUBJECTED TO SHARP BENDS DURING INSTALLATION
- (3) THROTTLE CABLE MUST BE ROUTED SMOOTHLY AND FREE OF WIRES, HOSES OR OTHER OBSTRUCTIONS BETWEEN CONDUIT FITTINGS

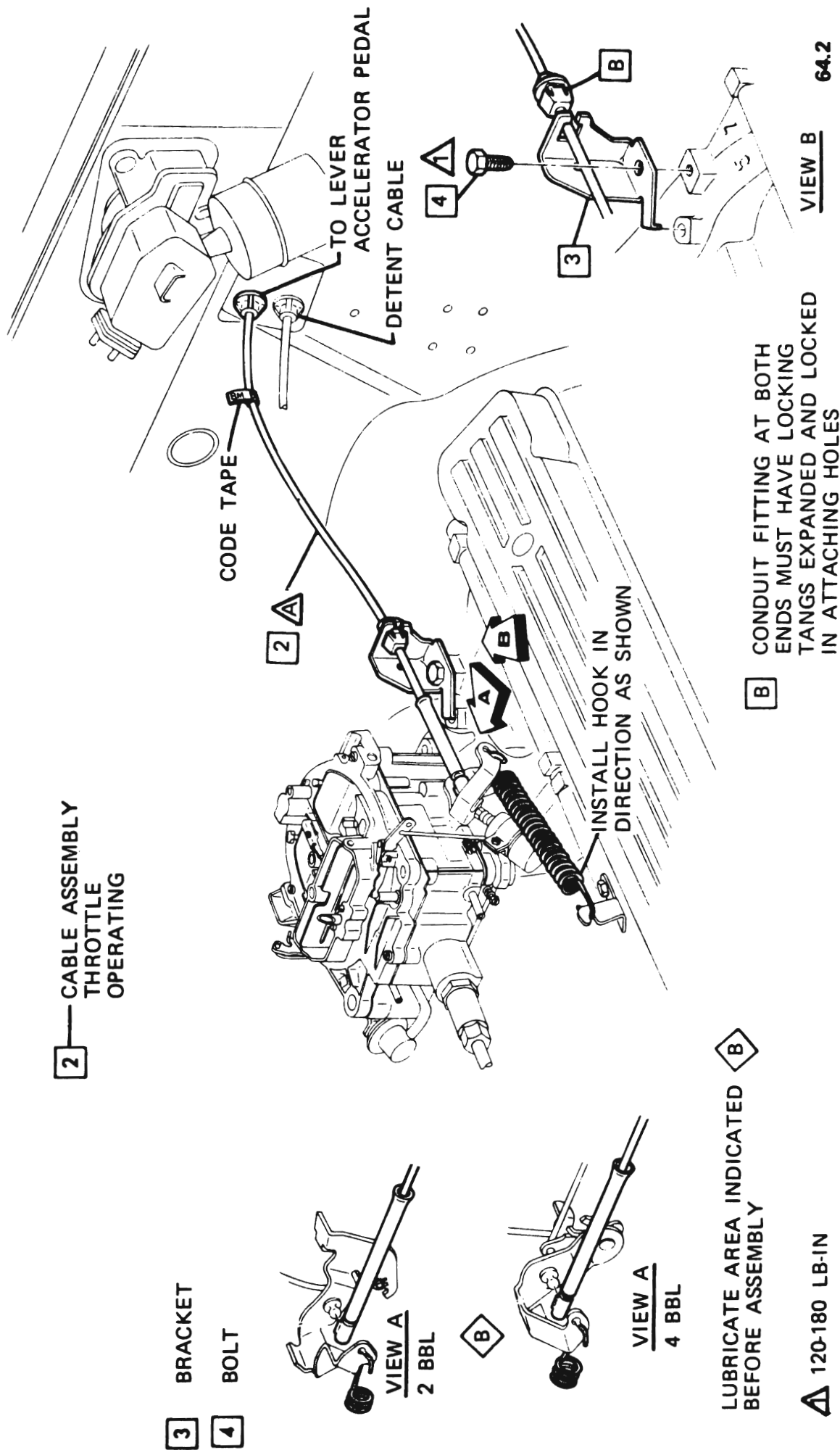
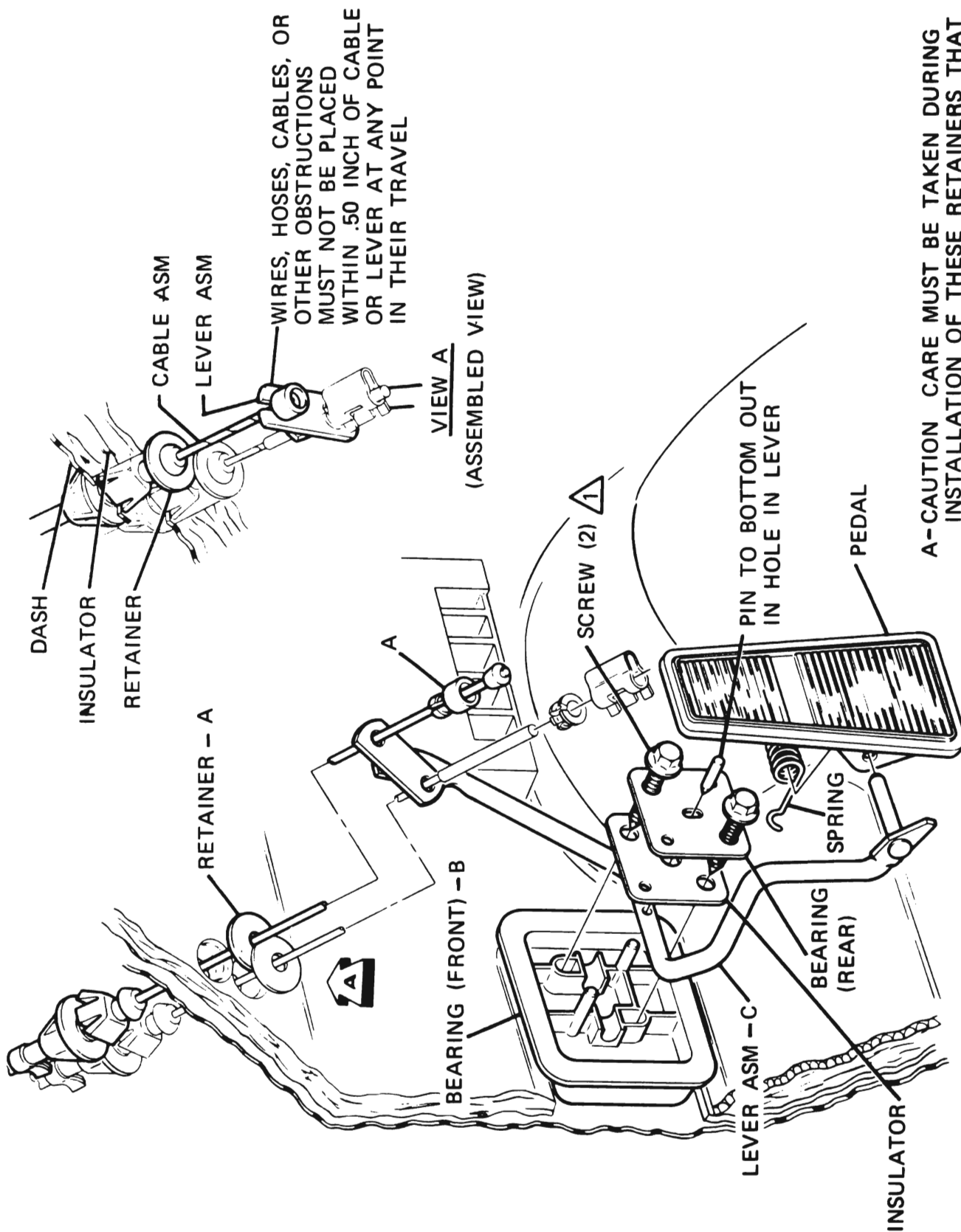

Figure 64.2 Throttle Controls - Engine Compartment - 350 Engine - 4D-4F-4G-4H-4L-4N Series



A-CAUTION CARE MUST BE TAKEN DURING INSTALLATION OF THESE RETAINERS THAT THE CABLE IS NOT KINKED OR DAMAGED.

B - MOUNTING SURFACE BETWEEN SUPPORT AND DASH PANEL MUST BE FREE OF INSULATION

C - LEVER MUST ROTATE FREELY AFTER ASSEMBLY

1 20-35 LB-IN

Figure 64-3 Throttle Controls - Passenger Compartment - 350 Engine - 4D-4F-4G-4H Series

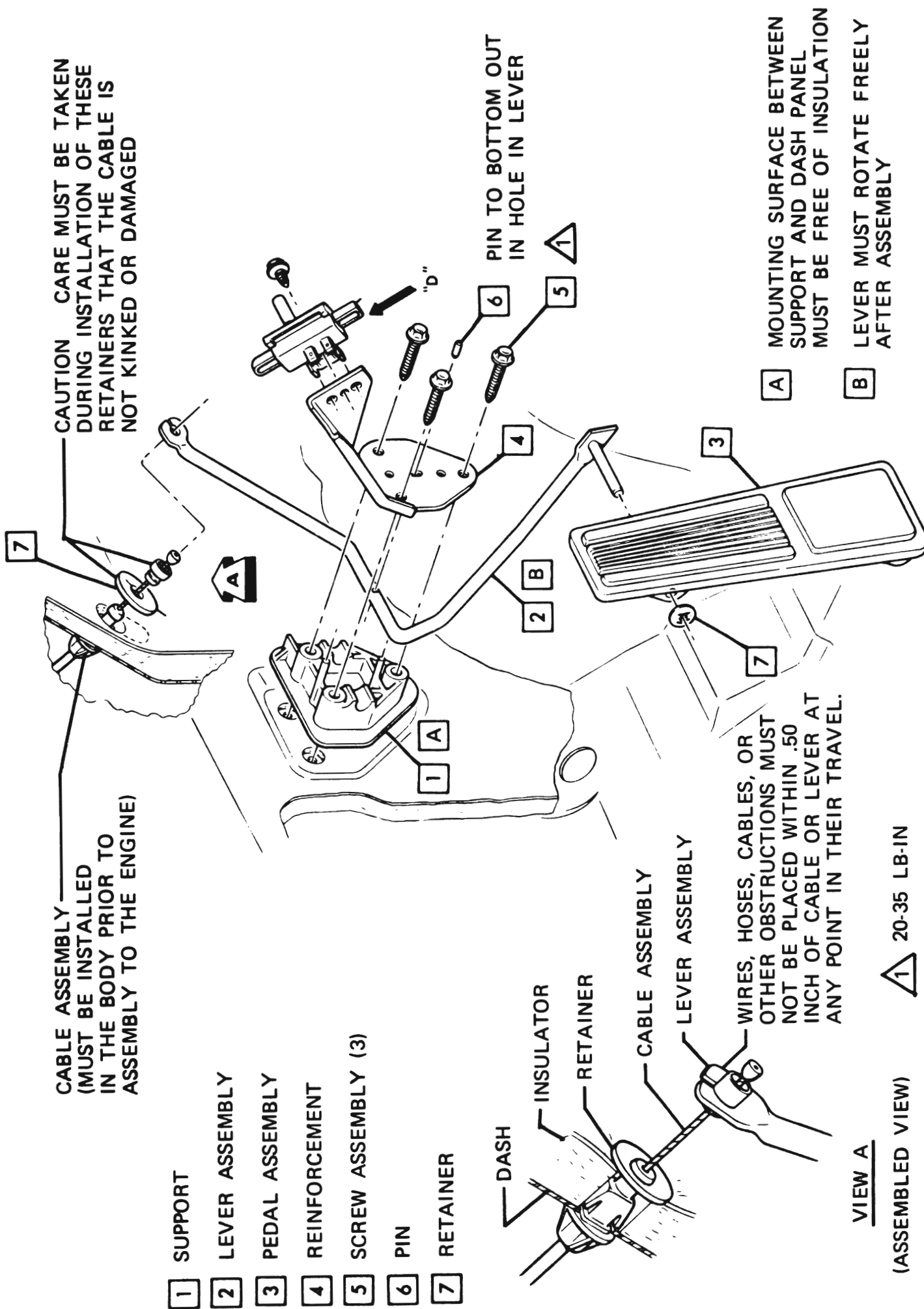

Figure 64-4 Throttle Controls - Passenger Compartment - 350 Engine - 4L-4N Series

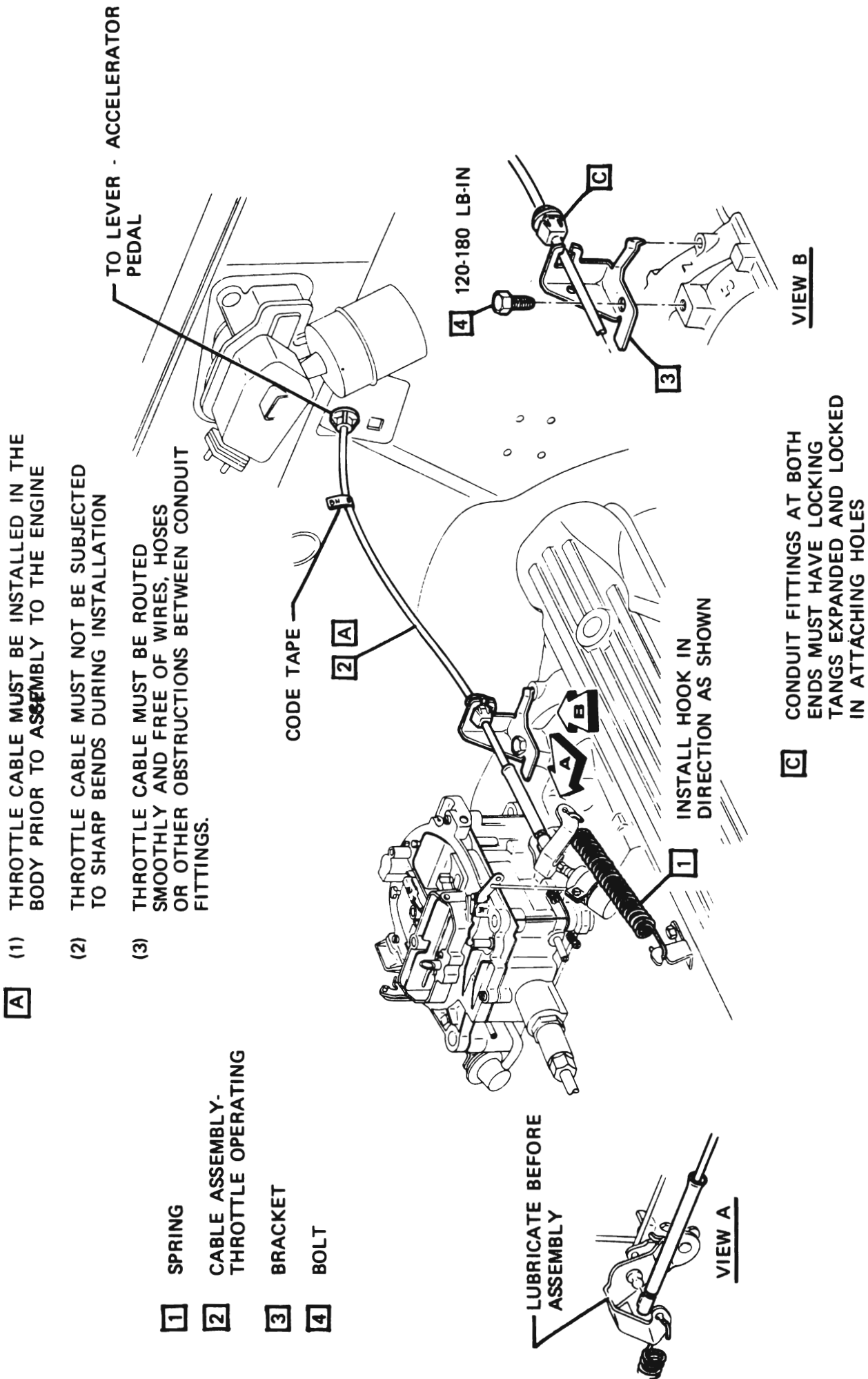

Figure 64-5 Throttle Controls - Engine Compartment - 455 Engine - All Except 4D-4F-4H Series

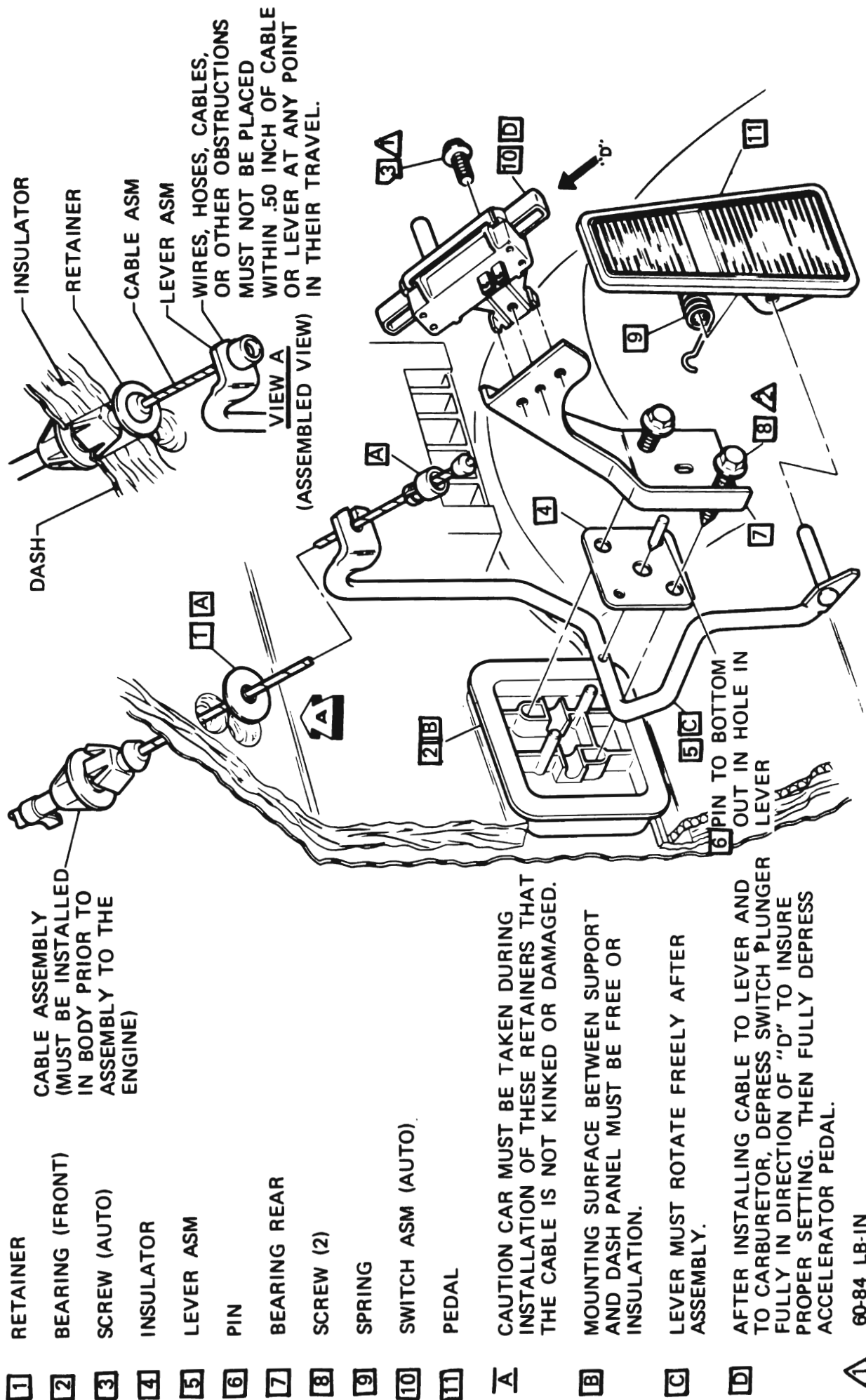

Figure 64-6 Throttle Controls - Passenger Compartment - 455 Engine - 4G Series

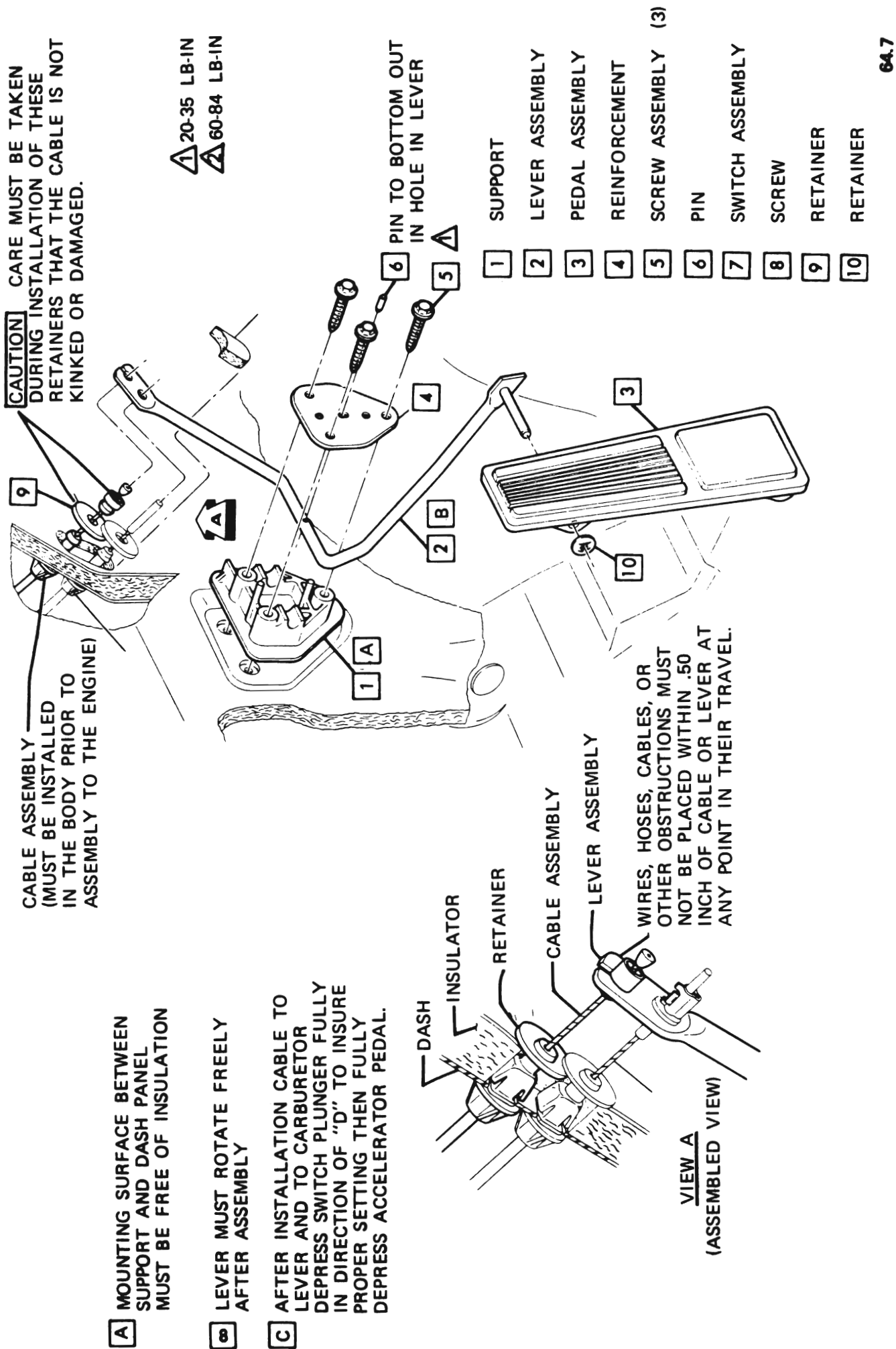
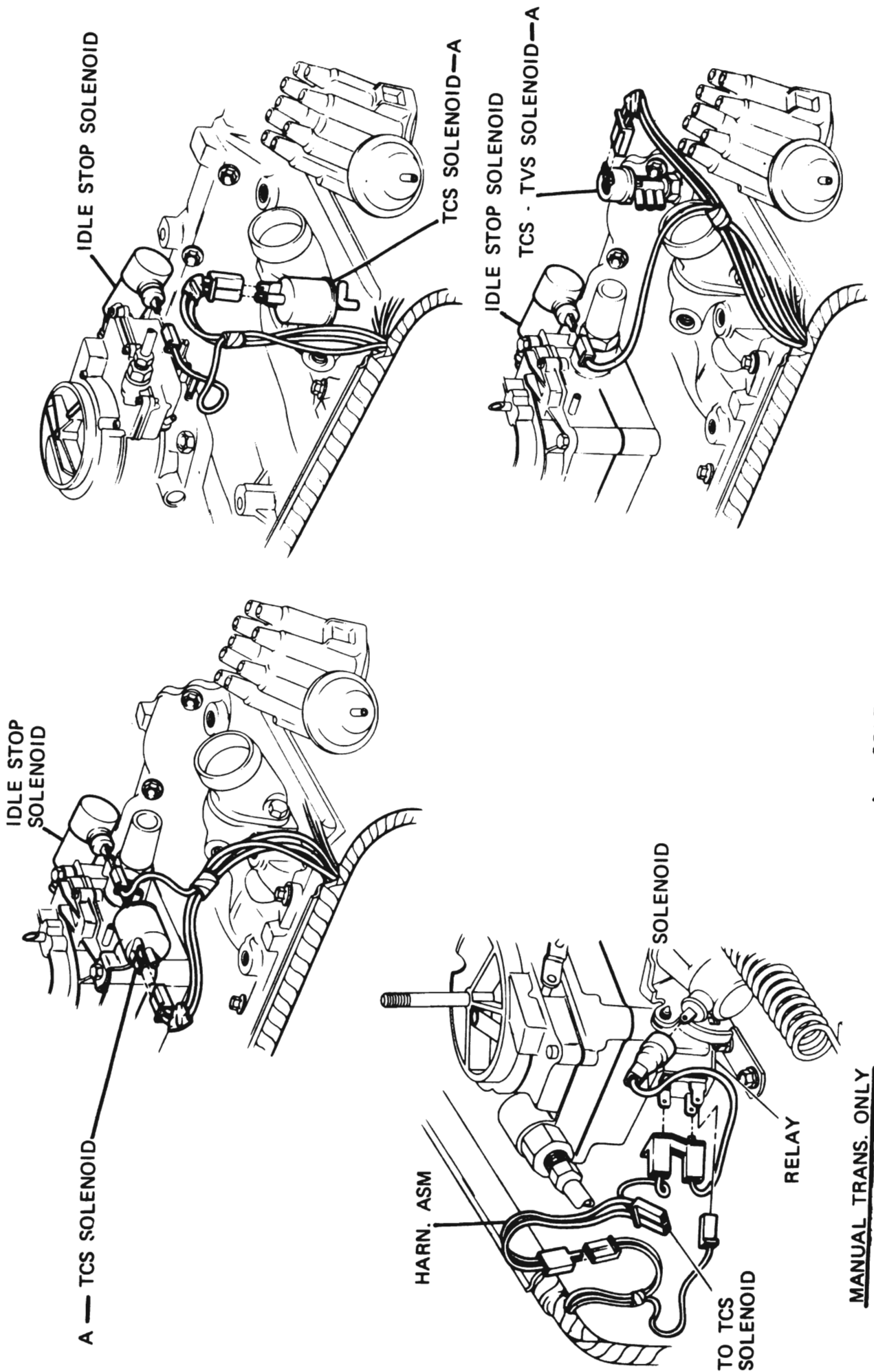

Figure 64-7 Throttle Controls - Passenger Compartment - 455 Engine - 4L-4N-4R-4P-4U-4V-4Y Series



A — SOLENOID WILL APPEAR IN ANYONE OF THESE POSITIONS

MANUAL TRANS. ONLY

Figure 64-9 Engine Idle Stop and TCS Solenoids - 4D-4F-4G-4H Series

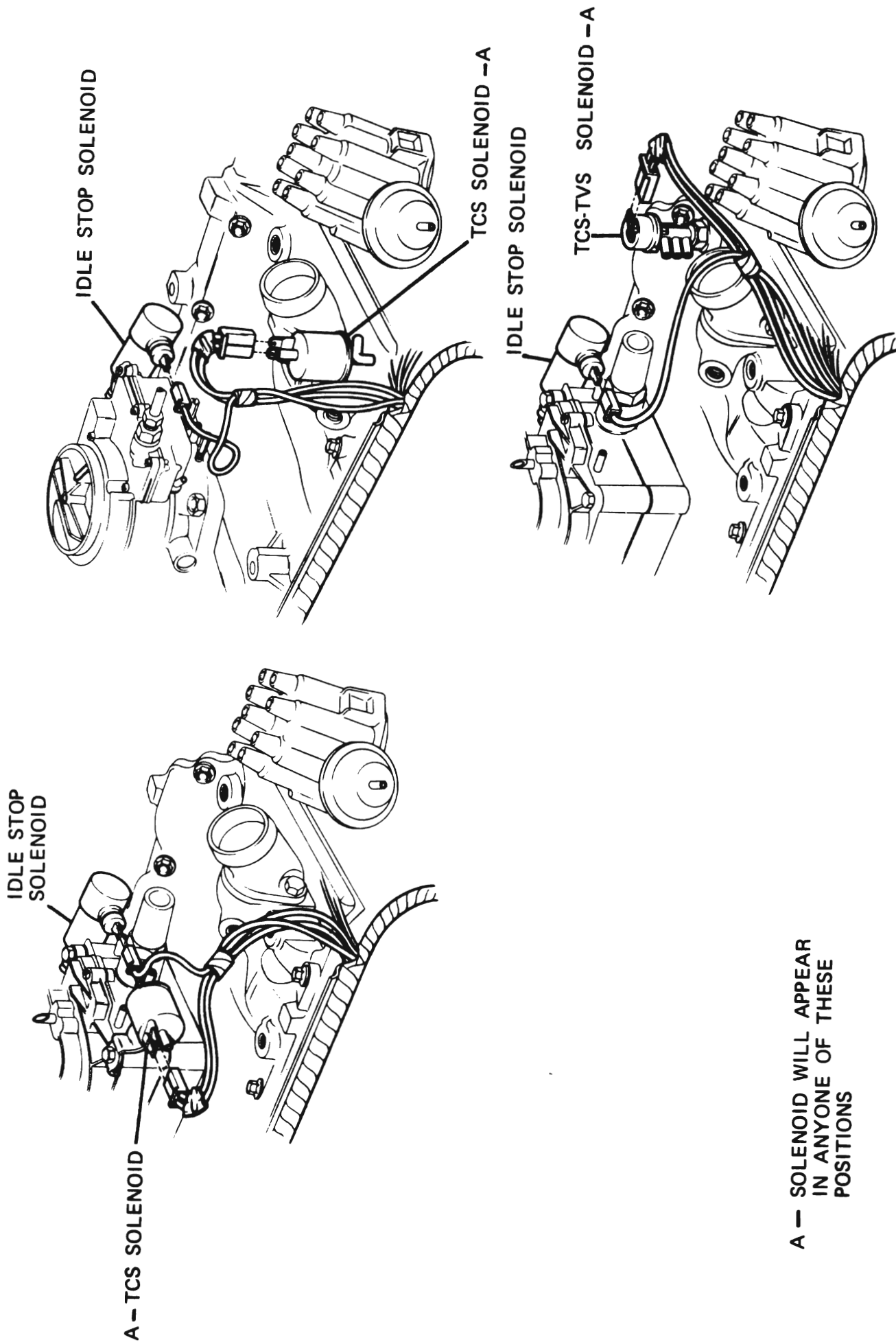

Figure 64-10 Engine Idle Stop and TCS Solenoids - 4L-4N-4R-4P-4U-4V-4Y Series