

SECTION B**FRONT SUSPENSION****4L-4N-4R-4P-4U-4V-4Y SERIES****CONTENTS**

Division	Subject	Page No.
I	TROUBLE DIAGNOSIS: Faulty Springs, Shock Absorbers and Ball Joints	30-27
II	DESCRIPTION AND OPERATION: Suspension Description	30-30
III	ADJUSTMENTS AND MINOR SERVICE: Front Wheel Alignment	30-31
	Wheel Bearing Adjustment	30-34
IV	REMOVAL AND INSTALLATION: Removal and Installation of Ball Joints and Steering Knuckle	30-34
	Removal and Installation of Upper Control Arm Assembly	30-37
	Removal and Installation of Lower Control Arm Assembly	30-38
	Removal and Installation of Front Springs	30-38
	Removal and Installation of Shock Absorbers	30-39
	Removal and Installation of Stabilizer Bar	30-39
V	OVERHAUL AND MAJOR SERVICE: (Not Applicable)	
VI	SPECIFICATIONS: Bolt Torque Specifications	30-40
	Dimensional Specifications	30-40

DIVISION I**TROUBLE DIAGNOSIS****30-14 FAULTY SPRINGS, SHOCK ABSORBERS,
AND BALL JOINTS****A. Trim Height Checking Considerations**

Optional equipment, undercoating, accumulated dirt, etc., change the car weight and must be considered

when checking spring trim dimensions. Because of the many possible variations in loading due to optional equipment, it is not possible to give dimensions for all conditions; therefore, the spring trim dimensions following are for the standard car only, without optional equipment or undercoating and with car at curb weight. Curb weight includes a full tank of gas, oil, water, and spare tire but no passengers.

Before measuring spring trim dimensions, bounce both ends of the car up and down several times to make sure there is no bind in suspension members, and to let springs take a natural position.

B. Measuring Trim Height

1. On a new car, the *front* spring trim dimension "K" should be as shown in Figure 30-43. On a car having service miles the trim height may be less due to normal settling of bushings, dirt accumulation, etc.

2. On a new car, the *rear* spring trim dimension "L" should be as shown in Figure 30-43. On a car having service miles the trim height may be less due to normal settling of bushings, dirt accumulation, etc.

3. When checking *side to side* differences in trim height at the *front* take measurements at the front rocker panel as shown in Figure 40-3.

A maximum of two (2) front shims may be installed on top of the front spring with a change in trim height double the thickness of the shims. This will provide for a maximum correction at the fender of .50 inch. A maximum of two (2) rear shims may be installed between the rear spring and the spring seat on the axle with a change in trim height the same as the thickness of the shims. This will provide for a maximum correction at the fender of .24 inch. Cars with 1 inch tilt right to left cannot be corrected by shims. If side to side variation is in excess of one inch, check suspension components for damage, excessive wear, or incorrect spring installation. See subparagraph c following for front shim installation.

4. When checking side to side differences in trim height at the *rear* take measurements at the rear rocker panel as shown in Figure 40-4. If shimming is required, see subparagraph c following.

Shimming of only one rear spring is not effective in correcting tilt. Side to side variation should be corrected by changing or shimming front springs.

C. Installation of Front Spring Shim

To correct variations in trim height, front spring shims may be ordered from the Parts Department under Group 7.425.

1. Remove front spring from car as described in paragraph 30-21.

2. Place shim at top of spring as shown in Figure 30-26. Taping shim to spring will aid installation.

3. Install shimmed spring in car per paragraph 30-21.

D. Weak and Non-Operative Shock Absorbers

Many shock absorbers have been replaced and returned to the factory with the report that they were weak or leaking oil. When tested with special factory equipment very few of these replaced units have been found weak, leaking oil, or otherwise below standard in operation. This indicates that these shock absorbers were needlessly replaced in an attempt to improve riding conditions which were actually standard, or that erroneous methods were used in judging the operating condition of the units.

Leaking shocks should not be diagnosed by observing a light oil film on or around the shock.

The shock absorber seal is designed to allow for lubrication of the piston rod, which under normal conditions, causes a light oil film to accumulate on the shock. This does not affect shock operation nor is replacement necessary as *all Delco shocks contain an added fluid reserve for this purpose.*

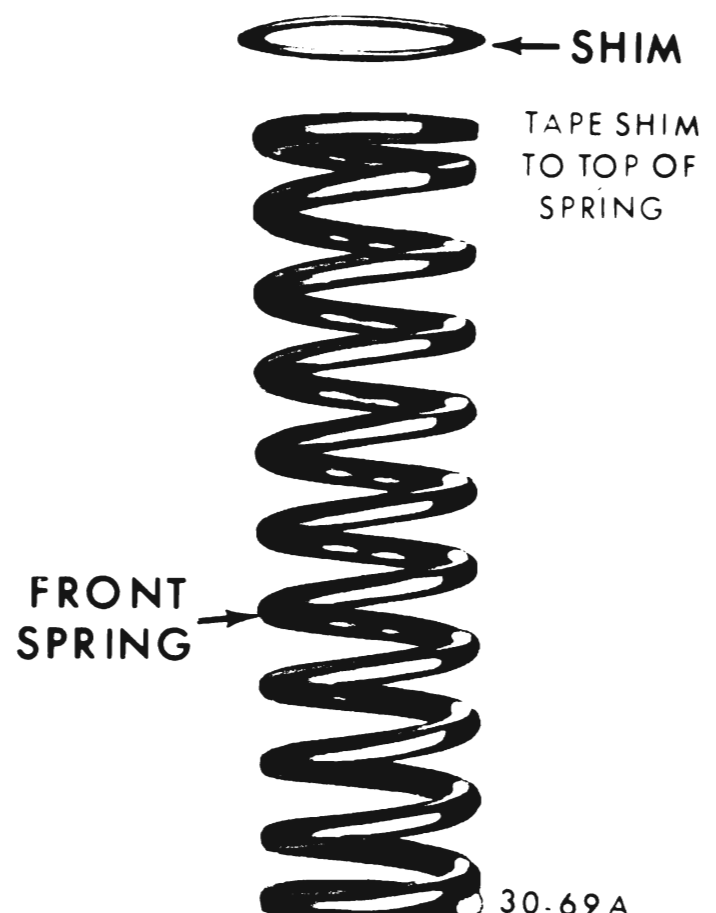

Figure 30-26 - Installing Shim on Spring

A leaking shock absorber is easily spotted as there will be evidence of fluid droplets on or around the shock. Before replacing any shock absorber, verify that the oil present on the shocks is not from some other chassis component.

Before attempting to test shock absorbers make sure that all attaching bolts and nuts are tight. Tires should be uniformly inflated to specified pressure (Group 100). The chassis should be well lubricated to make sure that suspension parts are free moving.

Test each front and rear shock absorber in turn by quickly pushing down and then lifting up on the end of the car bumper closest to the unit being checked. Use the same amount of force on each test, and note the amount of resistance provided by the shock absorber on compression and rebound. A little practice on another car of the same model which has satisfactory ride control will aid in judging the amount of resistance that should exist. Both front shock absorbers should provide the same feeling of resistance as should both rear shock absorbers. Any noticeable variation between right and left shock absorbers indicates that one unit is not operating normally. Little or no resistance on compression or rebound indicates air in the shock absorbers, internal leakage due to wear, or that the valve is held open by dirt. Excessive resistance indicates that the bleeder holes in the valve are plugged with dirt.

If there is any doubt about the action of a shock absorber after testing as described above, remove the unit from car. Mount it vertically in a vise with the jaws gripping the lower mounting firmly, then move the piston rod up and down by hand. There should be no free movement in this test. Lack of resistance or jerky resistance to movement indicates air in the shock absorber, internal leakage due to wear, or that the valve is held open by dirt. A faulty shock absorber must be replaced as it cannot be disassembled for repairs. In the test given above, the amount of force that can be applied is not sufficient to open a valve against its spring pressure; therefore, this test only checks the flow of fluid through the valve bleeder hole as well as any leakage due to a valve being held open, or due to internal wear of piston and cylinder. Since it is unlikely that the valve springs will weaken in service, it may be assumed that the shock absorber action is normal, if it operates satisfactorily in the test given above.

E. Loose Ball Joints

The upper ball stud is rubber spring equipped and thus preloaded in its socket at all times. This minimizes looseness at this point and compensates for normal wear. If the upper stud has any perceptible lateral shake, or if it can be twisted in its socket with the fingers, the upper ball joint should be replaced.

The lower ball joint is also rubber spring loaded and is held seated by the weight of the car. With the chassis spring load removed from the ball joint, this ball joint should not show any looseness. If looseness is noted, ball joint should be replaced.

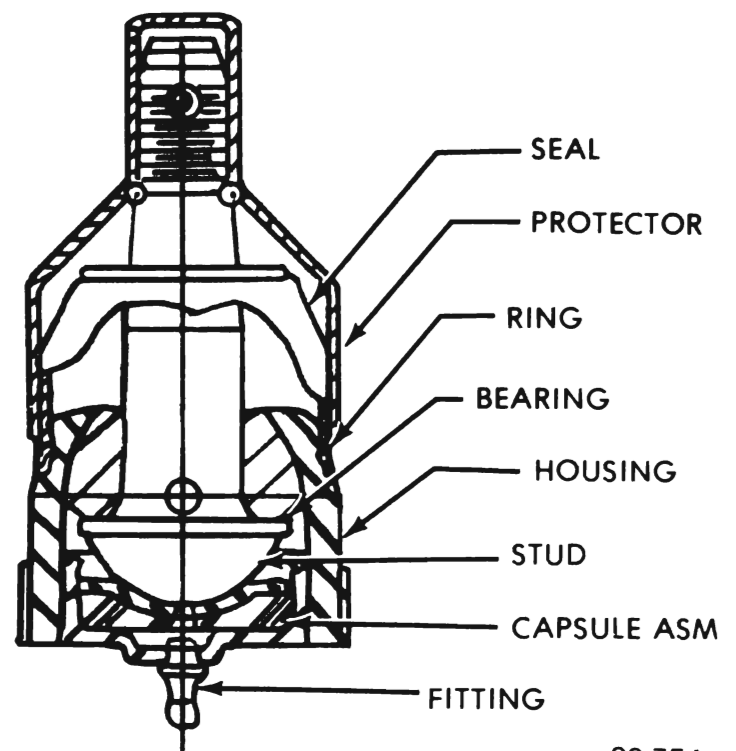

30-75A

Figure 30-27 - Lower Ball Joint Construction

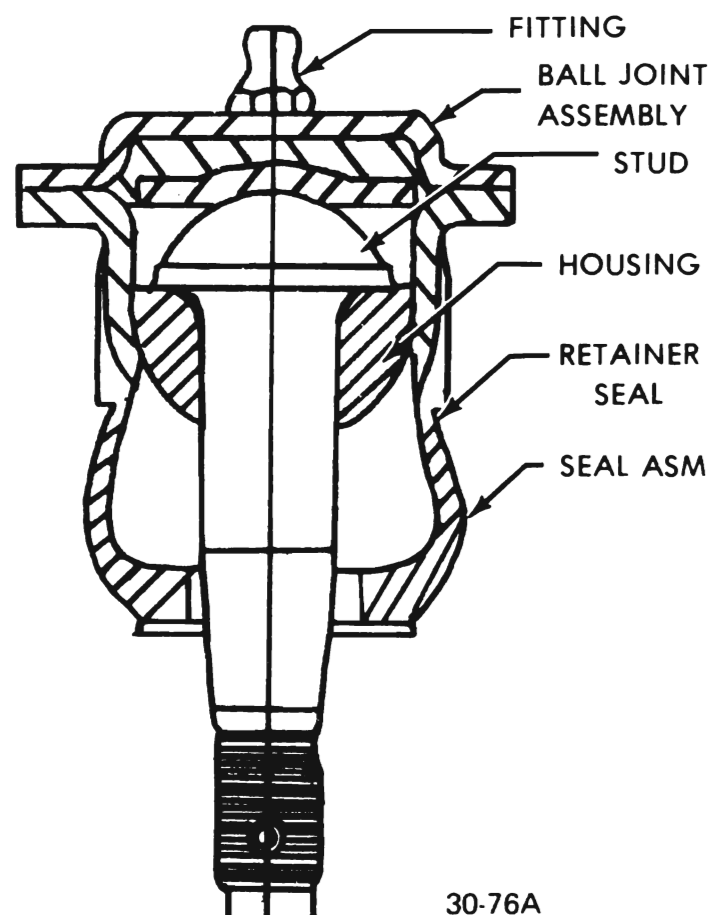

30-76A

Figure 30-28 - Upper Ball Joint Construction

The upper and lower ball joints are checked for wear by checking the torque required to rotate the ball joint in the assembly. After dislodging the ball joint from the steering knuckle, proceed as follows:

1. Install the stud nut to the ball stud.
2. Check the torque required to rotate the ball stud in the seat. Specified rotating torque for a new joint is 2 to 10 lb.ft.
3. If torque readings are excessively high or low and the joint is properly lubricated, replace the ball joint.

F. Loose Upper Control Arm Bushing Retaining Bolts

If loose upper control arm bushing retaining nuts are encountered, it is necessary to torque nuts to 55 lb.ft. On some cars equipped with air conditioning, power brakes, etc. it might be necessary to remove the upper control arm per paragraph 30-19 to torque the bolts. Bolts should be tightened with the car at curb height.

DIVISION II

DESCRIPTION AND OPERATION

30-15 SUSPENSION DESCRIPTION

The front suspension is designed to allow each wheel to compensate for changes in the road surface level without appreciably affecting the opposite wheel. Each wheel is independently connected to the frame by a steering knuckle, ball joint assemblies, and upper and lower control arms. The control arms are specifically designed and positioned to allow the steering knuckles to move in a prescribed three dimensional arc. The front wheels are held in proper relationship to each other by two tie rods which are connected to steering arms on the knuckles and to an intermediate rod.

Coil chassis springs are mounted between the spring housings on the frame and the lower control arms. Ride control is provided by double, direct acting shock absorbers mounted inside the coil springs and attached to the lower control arm by bolts. The upper portion of each shock absorber extends through the frame bracket and is secured with two grommets, two grommet retainers, and a nut.

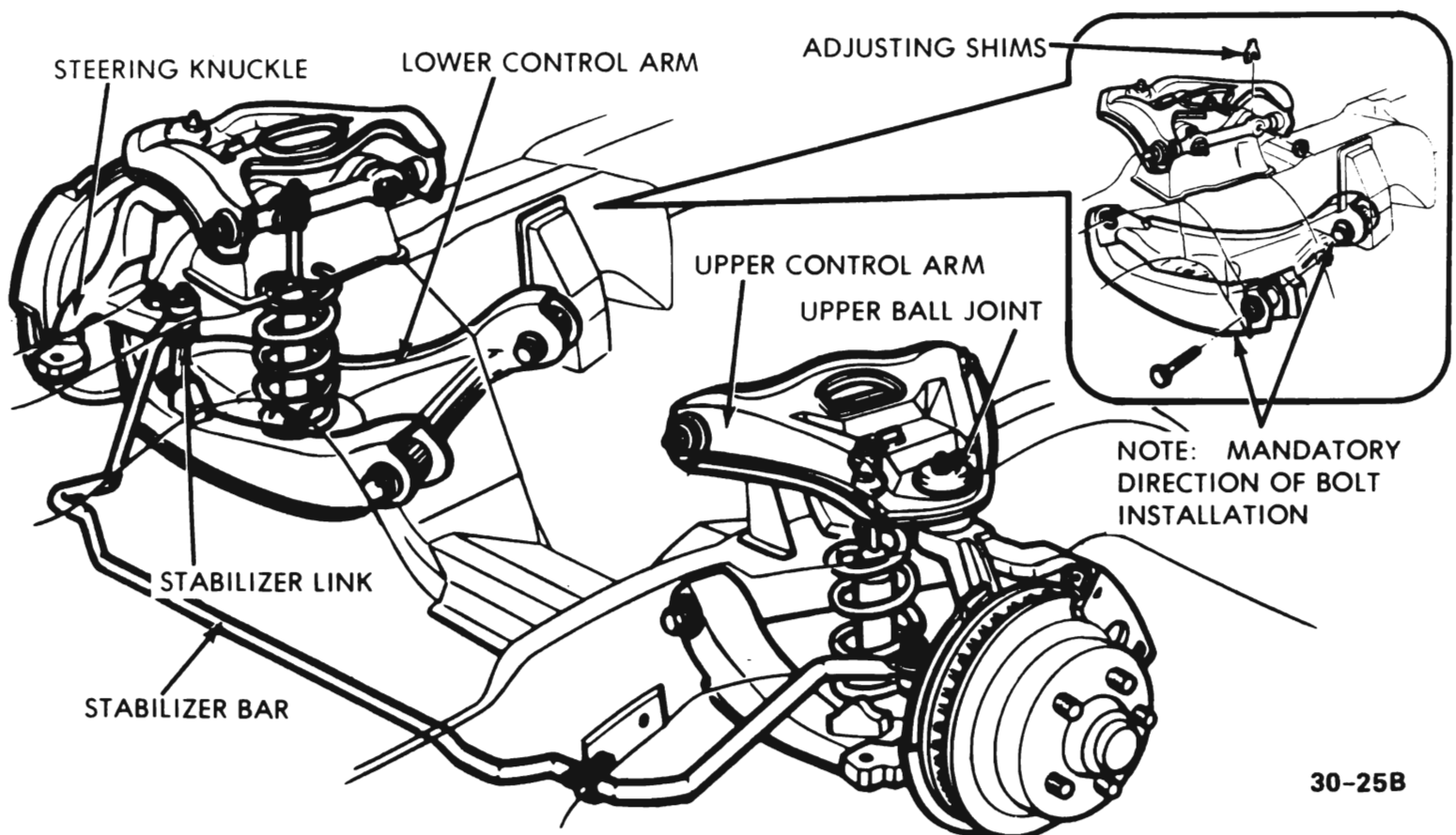

30-25B

Figure 30-31 - Front Suspension

Side roll of the front suspension is controlled by a spring steel stabilizer shaft. It is mounted in rubber bushings which are held to the frame side rails by brackets. The ends of the stabilizer are connected to the lower control arms by means of links which are isolated by rubber grommets which provide flexibility and ride features.

A ball joint is riveted to the outer end of the upper arm. The upper control arm is attached to a cross shaft through rubber bushings. The cross shaft, in turn, is bolted to frame brackets. It is pre-loaded by a rubber spring to insure proper seating of the ball in the socket.

The inner ends of the lower control arms are bolted to the frame through rubber bushings. The outer end of each arm is connected to the steering knuckle with a ball joint assembly pressed in the lower control arm and bolted to the steering knuckle. Fore-aft alignment is maintained by the wide span lower control arm.

Rubber seals are part of the ball joint assemblies to keep dirt and moisture from entering the joint and damaging bearing surfaces.

Shock absorbers are Delco direct double-acting type. Details on the operation of this type of shock absorber can be found under paragraph 30-3, Section A.

DIVISION III

ADJUSTMENTS AND MINOR SERVICE

30-16 FRONT WHEEL ALIGNMENT

Wheel alignment is the process of adjusting the position of the front wheels in order to attain proper vehicle handling characteristics and the least steering effort with a minimal amount of tire wear.

Wheel and tire balance has an important effect on steering and tire wear. If wheels and tires are out of balance, "shimmy" or "tramp" may develop causing tires to wear unevenly and give the erroneous impression that the wheels are not in proper alignment. For this reason, the wheel and tire assemblies should be known to be in proper balance before assuming that the front suspension is out of alignment.

Close limits on front wheel caster, camber, and theoretical king pin inclination are necessary for proper car handling, but require only reasonable accuracy to provide normal tire life. With the type of front suspension used, the toe-in adjustment is usually more important than caster and camber as far as tire wear is concerned.

In the majority of cases, services consisting of inflating tires to specified pressure and interchanging tires at recommended intervals, balancing all wheels and tires, adjusting steering gear and setting toe-in correctly will provide more improvement in car handling and tire wear than will front end alignment adjustments.

The correct use of accurate front end alignment equipment is essential to determine whether front suspension parts have been damaged, and to obtain correct alignment settings after new parts have been installed.

A. Inspection Before Checking Front Wheel Alignment

Before making any adjustment affecting caster, camber, toe-in, theoretical king pin inclination, or steering geometry, the following checks and inspections should be made to insure correctness of alignment equipment readings and alignment adjustments.

1. Front tires should have approximately the same wear and all tires must be inflated to specified pressures (Refer to Group 100).
 2. Check front wheel bearings for looseness and adjust if necessary (par. 30-17).
 3. Check for run-out of wheels and tires.
 4. Check wheels and tires for balance and correct if out-of-balance (Refer to Group 100).
 5. Check for looseness at ball joints, tie rod ends, and steering relay rods; if found excessive, it must be corrected before alignment readings will have any value.
 6. Check trim height; if out of limits, correct with shims or replace spring. Consideration must be given the optional equipment on the car, undercoating, dirt, etc. Vehicle should be at curb or free height when an alignment operation is performed. (All excess equipment, such as tool boxes, fishing or golfing equipment should be removed from the vehicle.) The vehicle should have a full tank of fuel.
- Good judgment should be exercised before replacing a spring when car trim height is only slightly out of limits. Spring replacement under conditions of excessive weight as mentioned above will accomplish little and must be accompanied by shimming to obtain satisfactory results. Front and rear shims are available through the Parts Department. Refer to paragraph 30-21 for front springs and Group 40 for rear springs.
7. It is advisable to check the condition and accuracy of any equipment being used to check front end

alignment and to make certain that instructions of the manufacturer are thoroughly understood and followed.

B. Checking Caster and Camber Settings

Caster is the forward or rearward tilt of the steering knuckle pivot centerline from true vertical as viewed from the side of the vehicle. If the top of the steering knuckle pivot centerline is tilted forward of true vertical, it is called "negative caster." If the top of the steering knuckle pivot centerline is tilted rearward of true vertical, it is called "positive caster."

Camber is the inward or outward tilt of the top of a wheel from true vertical as viewed from the front of the vehicle. If the top of a wheel is tilted outward from true vertical, it has "positive camber." If the top of a wheel is tilted inward from true vertical, it has "negative camber."

Since caster and camber settings are both adjusted by shimming in the same locations, both of these settings must be checked before changing shims.

Regardless of equipment used to check caster and camber, the car must be on level surface both transversely and fore and aft.

When alignment equipment is used which bears against the tire or wheel rim to obtain readings, it is very essential that the tires or wheels be checked for lateral run-out.

Caster and camber readings must be taken at points on the wheels which have no run-out or which lie in the same plane. Caster and camber should be within the service limits shown in Figure 30-42. Note that the caster angles at both front wheels need not be exactly the same but must be within 1 degree of each other. Likewise, the camber angles on both sides must be within 1 degree of each other. If caster and camber are not within the specified limits, adjust in the following manner.

C. Caster and Camber Adjustment

For caster and camber adjustment purposes, use the following guide:

1. To increase camber only - (More positive) Remove and equal amount of shims from front and rear bolts.
2. To decrease camber only - (Less positive) add an equal amount of shims to front and rear bolts.
3. To increase caster only - (More positive) Remove an amount of shims from front bolt and add an equal amount of shims at rear bolt.
4. To decrease caster only - (Less positive) Add an

amount of shims at the front bolt and remove an equal amount of shims from the rear bolt.

5. To increase caster and camber at the same time - remove an amount of shims *at front bolt only*.

6. To decrease caster and camber at the same time - add an amount of shims *at front bolt only*.

The following guide lines will help you select and correctly shim with minimum effort. Shim thickness limit for any one stack is .600 of an inch.

Shims are available in .030', .060', and .120' thickness.

By adding a pack of shims .090' thick at both sides, camber will be decreased by approximately 1/2 degree.

By adding a .030' shim on one bolt and removing a .030' shim from the other, caster will change approximately 3/8 degree.

To help you determine the shim thickness change required to return caster and camber to design dimension, two dimension change charts have been developed to enable you to do quicker and more accurate work. See Figure 30-41. This chart indicates in thousandths of an inch, the change required at (F) front and (R) rear shim position in order to return the initial reading to factory specifications. For example: Assume the initial readings for one B Series wheel were, camber minus 1/4 degrees and caster minus 1/4 degrees. Figure 30-41 indicates that an addition of plus 0.15 shim thickness to the (F) front shim position and addition of plus 0.06 shim thickness to the (R) shim position would be required to adjust this wheel to factory specifications.

Torque control arm shaft nuts to 75 lb. ft.

It is imperative that this torque specification be closely adhered to.

D. Checking Theoretical Kingpin (Steering Axis) Inclination

When checking theoretical king pin inclination, car must be on a level surface both transversely and fore and aft, must have trim heights within limits, and must be at curb load.

Set camber and caster to the desired specifications as shown in Figure 30-42. Measure king pin or steering axis inclination relative to a vertical plane. Add to the measured king pin axis angle the value of the positive camber angle (subtract if the camber is negative) and compare the resulting angle to the value given in Figure 30-43.

There is no adjustment for theoretical king pin inclination as this factor depends on the accuracy of

the front suspension parts. Distorted steering knuckles should be replaced with new parts.

Any heating, welding, or bending of front suspension parts to correct errors or repair damage must be avoided as this may produce soft spots in the metal in which fatigue and breakage may develop in service.

E. Checking and Adjusting Toe-In

Toe-in is the distance in fractions of an inch that the front of the wheels are turned inward from a straight-ahead position.

Car must be at curb weight and front and rear suspension trim should be within specified limits. Bounce front end and allow it to settle to operating height. Steering gear and front wheel bearings must be properly adjusted with no looseness at tie rod ends. The car should be moved forward one complete revolution of the wheels before the toe-in check and adjustment are started and the car should never be moved backward while making the check and adjustment. This presets the front suspension and removes lash from the joints.

1. Turn steering wheel to straight-ahead position, with front wheels in same position. See Figure 30- 9 for checking steering gear straight-ahead position.

2. Using a suitable toe-in gauge, measure the distance between outside walls of tires at the front at a height approximately horizontal to floor and through the centerline of the wheel assembly. An accurate check also can be made by raising and rotating front wheels to scribe a fine line near the center of each tire, then, with tires on the floor and front end at running height, measure between scribed lines with a suitable trammel.

3. Roll the car forward until measuring points on tires are approximately 180 degrees from point used in Step 2 above.

The measurement at the front should be $1/16''$ to $5/16''$ less than the measurement at the rear ($5/64''$ to $21/64''$ for Riviera).

4. If toe-in is not within specified limits, loosen clamp bolts and turn adjusting sleeves at tie rod ends as required. Decrease toe-in by turning left sleeve in same direction as wheel rotates moving forward and turn right sleeve in opposite direction. Increase toe-in by turning both sleeves in opposite direction.

Left and right adjusting sleeves must be turned exactly the same amount but in opposite directions when changing toe-in, in order to maintain front wheels in straight-ahead position when steering wheel is in straight-ahead position.

CASTER AND CAMBER ADJUSTMENT

FOR CASTER AND CAMBER DIMENSIONS, SEE WHEEL ALIGNMENT AND SPEC CHART.

FOR INCREASED OR POSITIVE CASTER, DECREASE SHIMS AT BOLT "A" AND INCREASE SHIMS AT BOLT "B" BY TWICE THIS AMOUNT

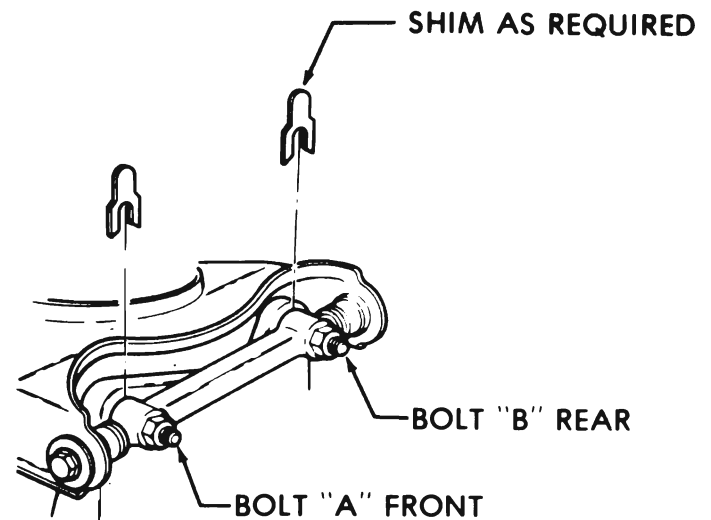

FOR DECREASED OR NEGATIVE CASTER, INCREASE SHIMS AT BOLT "A" AND DECREASE SHIMS AT BOLT "B" BY TWICE THIS AMOUNT

FOR INCREASED CAMBER, DECREASE SHIMS AT BOTH "A" AND "B" BOLTS. SHIMMING GREATER THAN .750 NOT PERMISSIBLE

SHIM THICKNESS AT "A" AND "B" LOCATION TO BE WITHIN .40 OF EACH OTHER

30-58 B

Figure 30-32 - Upper Control Arm Shimming Locations

Approximately the same amount of thread engagement in the adjuster sleeve should be noted for the inner and outer tie rod ends. The distance between the inner and outer tie rod ends in the adjuster sleeve should be approximately equal for both right and left wheels. The tie rods should never be lengthened to the point where the inner and outer threaded tie rod ends are outboard of the inner edge of the adjuster sleeve "U" clamps. If proper toe-in cannot be obtained within this amount of adjustment, inspect the suspension and steering linkage for bent parts.

5. After correct toe-in is secured, tighten clamp bolts securely.

The steering knuckle and steering arm "rock" or tilt as front wheel rises and falls. Therefore, it is of vital importance to center the travel of the inner tie rod joint by centering the tie rod stud in the socket (socket front face should be approximately vertical) and then position the bottom face of tie rod end parallel with machined surface at outer end of steering arm when tie rod length is adjusted. Severe damage and possible failure can result unless this precaution is observed. Tie rod sleeve clamps must be positioned straight down plus or minus 15 degrees to provide clearance between the frame and the steering linkage for all combinations of wheel motions.

F. Checking Steering Geometry (Turning Angles)

Be sure that caster, camber, and toe-in have all been properly corrected before checking steering geometry. Steering geometry must be checked with the weight of the car on the wheels.

1. With the front wheels resting on full floating turntables, turn wheels to the right until the outside (left) wheel is set at 20 degrees. The inside (right) wheel should then be at the angle specified in Figure 30-43.

2. Repeat this test by turning front wheels to the left until the outside (right) wheel is at 20 degrees; the inside (left) wheel should then be at the angle specified in Figure 30-43.

3. Errors in steering geometry generally indicate bent steering arms, but may also be caused by other incorrect front end factors. If the error is caused by a bent steering arm, the complete knuckle must be replaced. Replacement of such parts must be followed by a complete front end alignment check as described above. Never heat or bend a steering arm or knuckle to correct steering geometry, since doing so may cause the part to break in service.

30-17 REPLACEMENT AND ADJUSTMENT OF FRONT WHEEL BEARINGS

A. Replacement of Bearings

1. Raise front of car and remove wheel with hub and drum assembly.

2. Remove outer race and outer bearing assembly from hub. Remove oil seal from hub so that inner race and bearing assembly can be removed from hub.

3. Clean and inspect all bearing parts. When inspecting or replacing race and bearing assemblies, make certain the assemblies are free to creep on spindle of steering knuckle. Wiping the spindle clean and applying bearing lubricant will permit creeping and prevent rust forming between races and spindle.

4. If bearings require replacement, drive the old outer races from the hub. Install new outer races with a soft (brass) drift, being certain to start each squarely into hub to avoid distortion and possible cracking.

5. Thoroughly pack both roller bearing assemblies with new wheel bearing lubricant. Remove surplus lubricant. Apply light coating of lubricant to spindle and inside surface of wheel hub.

6. Place inner race and bearing assembly in cup and install new oil seal.

7. Install wheel on spindle; then install outer race and bearing assembly, washer, and spindle nut.

8. Adjust bearings, as described in subparagraph b following.

B. Adjustment of Front Wheel Bearings - All Series

1. Hand spin wheel in forward direction.

2. "Snug-up" spindle nut to fully seat bearings, while wheel is spinning. This will overcome any burrs on threads.

3. Back off spindle nut until just loose (1/4 to 1/2 turn).

4. Hand "snug-up" spindle nut. Do not install cotter pin if hole in spindle lines up with a slot in spindle nut.

5. Loosen spindle nut a minimum of 1/12 turn or a maximum of 1/6 turn. Then insert new cotter pin. Under no circumstances is the spindle nut to be even finger tight.

6. When the bearing is properly adjusted, there will be from .002 to .006 inches end play (looseness).

7. Remove support at front lower control arm and lower car.

DIVISION IV

REMOVAL AND INSTALLATION

30-18 REMOVAL AND INSTALLATION OF BALL JOINTS AND STEERING KNUCKLE

A. Removal of Upper Control Arm Ball Joint Assembly

1. Support car on car stand at the frame so front suspension is in full rebound position.

2. Remove front wheel.

3. Remove upper ball stud cotter key.
4. Loosen but do not remove ball stud nut. Nut should be loosened not more than 1/8". If ball stud nut is removed, injury could result, since heavily compressed chassis spring will be completely released.
5. Install Tool J-23742-1 between ball stud and turn threaded end of tool until the ball stud is free of steering knuckle. Remove tool.
6. Place jack under lower control arm at spring seat. Raise jack until compression is relieved on upper control arm rubber rebound bumper.
7. Remove the stud nut and lift upper control arm from knuckle.
8. Place a wood block between the upper control arm and the frame to act as a support during the following operations.
9. Center punch the four rivets, as close to the center as possible.
10. Drill a 1/8" hole through the center of the rivets about 1/2 to 3/4 the length of the rivet.
11. Using a 7/32" drill, enlarge the hole, drilling again about 1/2 the length of the rivet.
12. With a chisel, remove the rivet heads.
13. Using a 3/4" punch and hammer, remove the rivets. Remove ball joint. Care must be used not to hit and damage the ball joint seat and rivet holes in the control arm.

B. Installation of Upper Control Arm Ball Joint

An inspection of the tapered holes in the knuckle should be made. If any out-of-roundness, deformation, or damage is noted, the knuckle should be replaced. Refer to paragraph e.

1. Install the new ball joint in the upper control arm and attach with the bolt and nut assemblies provided. Insert the bolts from the bottom with the nut on top. Torque to 8 lb ft.
2. Turn tapered stud so cotter pin hole is fore and aft. Remove the wood block from between the arm and the frame, move the knuckle up by jacking under outer edge of spring seat. Knuckle and brake drum assembly should be in a straight-ahead position.
3. Wipe tapered hole in knuckle and tapered stud free of dirt and grease, and assemble stud to knuckle with castellated nut. Torque to 50 lb.ft.
4. Never back off nut to align cotter pin holes. *Always*

tighten nut to next slot that lines up with hole in ball joint stud.

5. Install new cotter pin.

CAUTION: *This front upper control arm ball joint to steering knuckle fastener is an important attaching part in that it could affect the performance of vital components and systems and/or could result in major repair expense. It must be replaced with one of the same part number, or with an equivalent part if replacement becomes necessary. Do not use a replacement part of lesser quality or substitute design. Torque values must be used as specified during reassembly to assure proper retention of this part.*

4. Install wheel and tire.

C. Lower Ball Joint Removal

1. Raise front of car and place jack stands under frame side rails. Remove tire and wheel assembly.
2. For safety, place a floor jack under the lower control arm as far outboard on the arm as possible to gain maximum leverage advantage. Do not place the jack against the arm but about 1/2" below. Now remove cotter pin and loosen (do not remove) nut on lower ball joint tapered stud. Nut should be loosened not more than 1/8". If jack is not used and nut is removed, injury could result since heavily compressed chassis spring will be completely released.
3. Install Tool J-23742-1 between ball studs.
4. Turn the threaded end of J-23742-1 until the ball stud is free of steering knuckle. Remove tool.
5. Place the jack under the lower control arm at the spring seat. Raise the jack until compression is relieved on the upper control arm rubber rebound bumper. Remove the lower ball joint stud nut. Move the steering knuckle out of the way.
6. Install lower ball joint remover and installer as shown in Figure 30-33.
7. Tighten Detail J-9519-8 with a socket and handle until ball joint is forced out of the lower control arm. Ball joint may pop out suddenly.

D. Lower Ball Joint Installation

An inspection of the tapered holes in the knuckle should be made every time a ball joint is replaced. If any out-of-roundness, deformation or damage is noted, the knuckle should be replaced. Refer to paragraph e.

1. Position ball joint in lower control arm and install

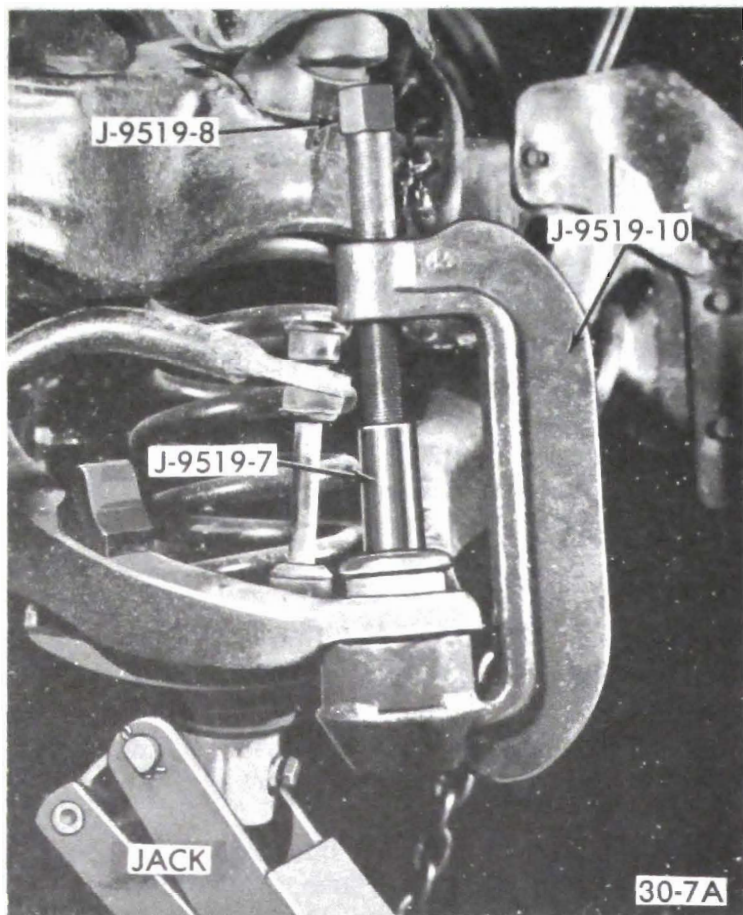

Figure 30-33 - Lower Ball Joint Remover in Place

Tool J-9519 as shown in Figure 30-34. Position bleed vent in rubber boot of the new ball joint facing inward.

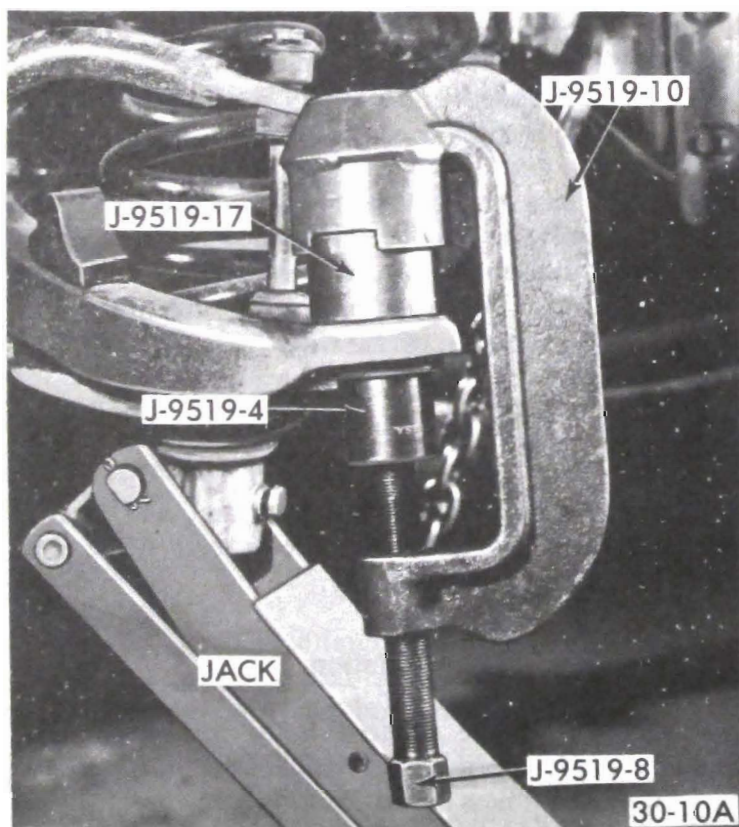

Figure 30-34 - Lower Ball Joint Installer in Place

2. With a suitable socket and handle force the ball joint into the lower control arm until it is fully seated.

3. Turn the stud so the cotter pin hole is fore and aft. Knuckle should be in a straight-ahead wheel position. Stud and knuckle hole must be free of dirt and grease before assembly.

4. Position the tapered stud in the knuckle and install castellated nut. Tighten the nut to 85 lb.ft. Never loosen nut to align cotter pin holes. Always tighten nut to next slot that lines up with hole. Install new cotter pin.

CAUTION: *This front lower control arm ball joint to steering knuckle fastener is an important attaching part in that it could affect the performance of vital components and systems, and/or could result in major repair expense. It must be replaced with one of the same part number or with an equivalent part, if replacement becomes necessary. Do not use a replacement part of lesser quality or substitute design. Torque values must be used as specified during reassembly to assure proper retention of this part.*

5. Install tire and wheel assembly. Adjust wheel bearing (paragraph 30-17). Remove car stand and lower car.

E. Removal and Installation of Steering Knuckle

It is recommended that the vehicle be raised and supported on a twin-post hoist so that the front coil spring remains compressed, yet the wheel and steering knuckle assembly remain accessible. If a frame hoist is used, support the lower control arm with an adjustable jack stand to retain spring in the curb height position.

1. Raise vehicle on a hoist and support the lower control arm.

2. Remove the wheel and tire assembly.

3. Remove the brake caliper and brake disc. Hang the brake caliper assembly from some part of the suspension assembly. Do not allow the unit to hang by the hydraulic line.

4. Remove the splash shield.

5. Remove upper and lower ball stud cotter pins.

6. Remove ball studs from steering knuckle, using Tool J-23742-1. See paragraph 30-18, sub-paragraphs a and c.

7. To install, place steering knuckle into position and insert upper and lower ball studs into knuckle bosses.

8. Install ball stud nuts and torque to specifications. If necessary, tighten one more notch to align cotter pin.

CAUTION: *The upper and lower control arm ball joint to steering knuckle fasteners are important attaching parts in that they could affect the performance of vital components and systems, and/or could result in major repair expense. They must be replaced with one of the same part number or with an equivalent part, if replacement becomes necessary. Do not use a replacement part of lesser quality or substitute design. Torque values must be used as specified during reassembly to assure proper retention of these parts.*

9. Install the splash shield and install hub and disc.

10. Install outer bearing and spindle washer and nut and adjust bearing.

11. Install brake caliper and tire and wheel.

12. Lower vehicle to floor.

30-19 REMOVAL AND INSTALLATION OF UPPER CONTROL ARM ASSEMBLY

A. Removal

1. Raise car with jack under frame. Remove wheel and tire.

2. Remove cotter pin from castellated nut on upper ball joint tapered stud.

3. Loosen, but do not remove nut. Force of chassis spring will be tending to disengage ball joint tapered stud from steering knuckle using Tool J-23742-1. See Figure 30-35. If ball stud nut is removed, injury could result since heavily compressed chassis spring will be completely released.

4. With another jack, support car weight under outer edge of lower control arm. Raise jack until compression is relieved on upper control arm bumper and remove castellated nut from ball joint tapered stud.

5. Wire brake and knuckle assembly in place to prevent damage to the brake hose, and rotate upper control arm upward and away from knuckle.

6. Remove the upper control arm shaft to frame bracket nuts, carefully noting the number, location, and thickness of adjusting shims between the shaft and frame bracket. Remove the control arm assembly. Remove rebound rubber bumper from arm.

7. Inspect stud hole in knuckle. If elongated or damaged, replace knuckle.

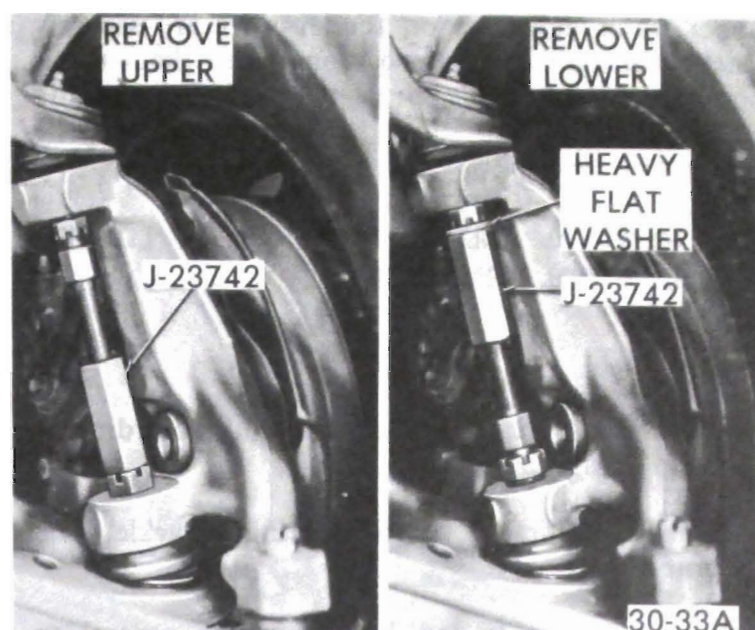

Figure 30-35 - Separating Steering Knuckle from Ball Joint

B. Installation

CAUTION: *Fasteners in steps 1, 2, and 3 are important attaching parts in that they could affect the performance of vital components and systems, and/or could result in major repair expense. They must be replaced with one of the same part number or with an equivalent part if replacement becomes necessary. Do not use a replacement part or lesser quality or substitute design. Torque values must be used as specified during reassembly to assure proper retention of these parts.*

1. Assemble upper control arm and shaft assembly to bracket, making certain the number, thickness and location of adjusting shims between shaft and bracket are correct. Assemble rubber rebound bumper to arm. Torque shaft to bracket nuts to 75 lb.ft. Those bolts may be torqued from within the engine compartment through the use of a standard 11/16"-1/2" drive socket and J-1313 Torque Wrench or its equivalent.

2. Make sure stud and tapered hole in knuckle are free of dirt and grease. Spindle should be in a straight-ahead wheel position when the stud is inserted. Assemble tapered stud to knuckle with cotter pin holes fore and aft. Install castellated nut. Torque to 35 lb.ft. *Never loosen nut to align cotter pin holes. Always tighten nut to next slot that lines up with hole.* Install new cotter pin.

3. With car at curb load, loosen upper control arm bushing to shaft bolts and bounce front end of car. Retorque bolts to 35 ft.lbs.

4. Install wheel. Check and adjust front end alignment. Adjust wheel bearings. When working in the area of the front upper control arm, make certain that the

rubber water deflectors on fender skirt are securely attached in their original positions when the work is completed. If reasonable care is exercised in removing the fasteners for these rubber deflectors, they may be satisfactorily reused.

30-20 REMOVAL AND INSTALLATION OF LOWER CONTROL ARM ASSEMBLY

A. Removal

1. Remove coil spring and stabilizer link according to outline in paragraph 30-21.
2. Remove ball stud from steering knuckle. See paragraph 30-18.
3. Remove two nuts and bolts securing control to frame.
4. Remove the control arm from vehicle.
5. If lower control arm is to be replaced, remove the rubber bumper and attaching nut.

B. Installation

1. Install new arm assembly with the arm to frame bolt head to the front of car. Install rubber side bumper to arm. Torque to 17 lb.ft. Make sure bolts point to rear of car.
2. Reinstall coil spring and stabilizer link as outlined in paragraph 30-21.
3. With the car at curb load, tighten control arm attaching bolt nut to 100 lb.ft.

CAUTION: *This front lower control arm to frame fastener is an important attaching part in that it could affect the performance of vital components and systems, and/or could result in major repair expense. It must be replaced with one of the same part number or with an equivalent part, if replacement becomes necessary. Do not use a replacement part of lesser quality or substitute design. Torque values must be used as specified during reassembly to assure proper retention of this part.*

4. Check and adjust front end alignment.

30-21 REMOVAL AND INSTALLATION OF FRONT SPRING

A. Removal

1. Raise front of car and support solidly with a car stand under the frame side rail on the side where the spring removal is to be performed.

2. Remove wheel and hub assembly.
3. Remove shock absorber according to outline in paragraph 30-22.
4. Remove the front stabilizer rod link from the lower control arm.
5. Remove tie rod.
6. Remove control arm bumper.
7. As a safety precaution place a floor jack under the lower control arm as far outboard as possible to gain maximum leverage advantage.

Do not place the jack against the arm, but about 1/2 inch below. Now remove the cotter pin and **LOOSEN, DO NOT REMOVE** the nut on the lower ball joint tapered stud. The nut should be loosened not more than 1/8".

8. Install Tool J-23742-1 between ball studs and turn threaded end of Tool J-23742-1 until ball stud is free of steering knuckle.
9. Raise the jack against the control arm to relieve pressure on the nut, remove the nut and separate the steering knuckle from the tapered stud.
10. Carefully lower the jack supporting the lower control arm to release the spring. With the jack all the way down to the floor it still may be necessary to pry the spring off its seat on the lower control arm with long pry bar. Caution should be exercised in handling this preloaded spring while it is still installed in the car. Care should be taken so the spring, when removed, does not damage the ball joint stud or seal.
11. Inspect stud and hole in knuckle. If stud is damaged or hole in knuckle is elongated, replace the necessary parts.

B. Installation

1. Position spring in upper seat with lower spring resting on lower control arm.
2. Raise lower control arm with jack and connect lower ball joint to steering knuckle. Do not tighten.
3. Lower jack so that control arm hangs free and install shock (lower mountings). Tighten screws to 20 lb.ft.

Fasteners in Steps 4, 5, 6, 7, 8, and 9 are important attaching parts in that they could affect the performance of vital components and systems, and/or could result in major repair expense. They must be replaced with one of the same part number, or with an equivalent part if replacement becomes necessary. Do

not use a replacement part of lesser quality or substitute design. Torque values must be used as specified during reassembly to assure proper retention of these parts.

4. Raise lower control arm with jack and torque lower ball joint nut to 95 lb.ft.
5. Install stabilizer link to control arm and torque nut to 12 lb.ft. See Figure 30-38.
6. Install tie rod end to knuckle and torque to 35 lb.ft.
7. Install lower control arm rubber bumper and torque nut to 17 lb.ft.
8. Install shock absorber upper nut and torque to 8 lb.ft.
9. Install wheel. Torque to 75 lb.ft.
10. Lower jack and remove. Recheck and adjust toe-in.

30-22 REMOVAL AND INSTALLATION OF SHOCK ABSORBERS

A. Removal

1. Remove upper shock absorber attaching nut, grommet retainer and grommet.
2. Remove the lower retaining screws. Lower shock through hole in lower control arm.

B. Installation

1. Select the correct shock absorber for the particular car model. Refer to Master Chassis Parts Catalog for correct absorber. Substitution of an incorrectly

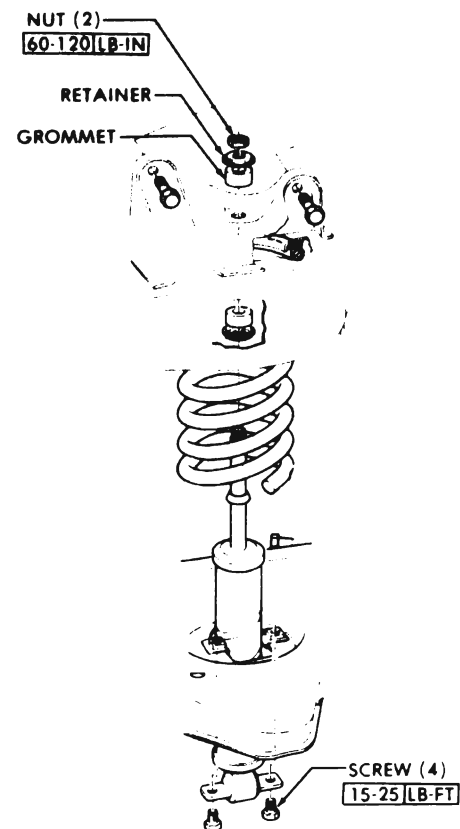

30-40A

Figure 30-39 - Shock Absorber Mounting Details

calibrated shock absorber will adversely affect car performance.

2. Assemble lower grommet retainer and grommet on shock stem. Extend shock and install through lower control arm. With shock upright in vise, push and pull shock rod through its full travel several times to pump out any air which might be trapped in the inner cylinder. Keep shocks upright until installed. It is a good idea to replace the shock absorber rubber grommets whenever a shock is removed or replaced.

3. Install shock, lower attaching screws. Torque to 20 lb.ft.

4. Assemble top grommet, grommet retainer, and nut on stem. Torque to 8 lb.ft.

30-23 REMOVAL AND INSTALLATION OF STABILIZER BAR

CAUTION: Fasteners in subparagraph A, B, and C are important attaching parts in that they could affect the performance of vital components and systems, and/or could result in major repair expense. They must be replaced with one of the same part number or with an equivalent part if replacement becomes necessary. Do not use a replacement part or lesser quality or substitute design. Torque values must be used as specified

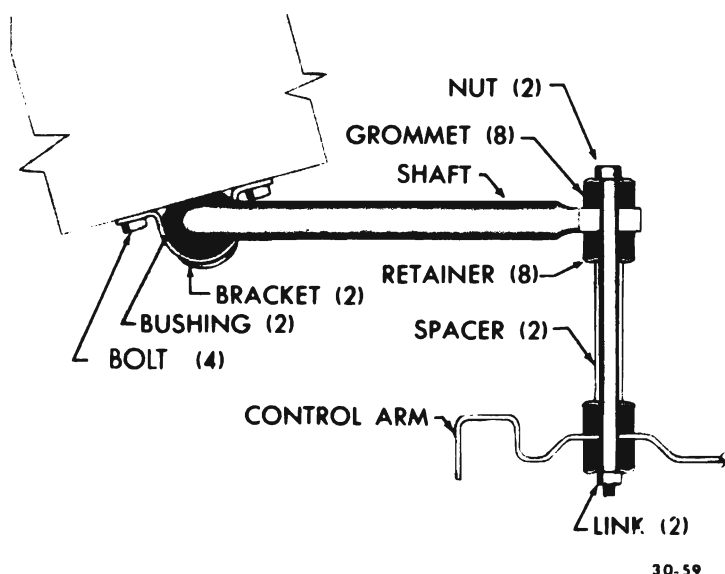

30-59

Figure 30-38 - Stabilizer Link Installation

during reassembly to assure proper retention of these parts.

A. Stabilizer Shaft, Removal and Replacement

Disconnect stabilizer links (subpar. c following) and disconnect the two frame-to-shaft insulator mounts and brackets.

To install, position insulator mounts and brackets over shaft and connect bracket to frame.

Torque bracket bolts to 24 lb.ft. Connect stabilizer links subparagraph c below. Do *not* lubricate insulator mounts.

B. Stabilizer Bracket and Insulator, Removal and Replacement

DIVISION VI

SPECIFICATIONS

30-24 BOLT TORQUE SPECIFICATIONS

Use a reliable torque wrench to tighten the parts listed to insure tightness without straining or distorting parts. These specifications are for clean and lightly-lubricated threads only; dry or dirty threads produce increased friction which prevents accurate measurement of tightness.

Parts	Location	Torque Lb.Ft.
Screws	Front Shock to Lower Control Arm	20
Nut	Front Shock to Frame	8
Screw	Stabilizer Bushing to Frame	24
Nut and Bolt	Upper Control Arm Shaft to Frame	Nut 75
Nut	Upper Ball Joint to Knuckle	50
Nut and Bolt	Front Lower Control Arm to Frame	Nut 100
Nut	Lower Ball Joint to Knuckle	95
Nut and Bolt	Stabilizer Link to Lower Control Arm	Nut 12
Nut, Bolt and Washer	Idler Arm to Frame	Bolt 65, Nut 35
Nut	Tie Rod End to Steering Knuckle	35
Nut	Lower Rubber Bumper to Lower Control Arm	17

30-25 DIMENSIONAL SPECIFICATIONS

Stabilizer Bar Diameter 4L-4N-4U-4V	13/16"
Stabilizer Bar Diameter 4R-4P-4Y	27/32"
Steering Knuckle Spindle Bearing Diameter	
Large End	1.3743-1.3748
Small End8730-.8435

Stabilizer brackets should be replaced if damaged, and rubber insulator mounts replaced if deteriorated.

Replace by supporting stabilizer shaft in position and replacing brackets and mounts one at a time. Torque bracket bolts to 24 lb.ft.

C. Stabilizer Link Removal and Replacement

1. Remove nut from lower end of link. Remove link, spacer, retainers and grommets. See Figure 30- 40.

2. Inspect link and grommets.

3. Install grommets dry and use care to center the grommets in the seats on stabilizer shaft and hole in control arm. Also, center the retainers on grommets before tightening link nut.

4. Tighten link nut to 12 lb.ft.

CASTER AND CAMBER ADJUSTMENT

FOR CASTER AND CAMBER DIMENSIONS, SEE WHEEL ALIGNMENT AND SPEC CHART.

FOR INCREASED OR POSITIVE CASTER, DECREASE SHIMS AT BOLT "A" AND INCREASE SHIMS AT BOLT "B" BY TWICE THIS AMOUNT

FOR DECREASED OR NEGATIVE CASTER, INCREASE SHIMS AT BOLT "A" AND DECREASE SHIMS AT BOLT "B" BY TWICE THIS AMOUNT.

FOR INCREASED CAMBER, DECREASE SHIMS AT BOTH "A" AND "B" BOLTS. SHIMMING GREATER THAN .760 NOT PERMISSIBLE.

SHIM THICKNESS AT "A" AND "B" LOCATION TO BE WITHIN .40 OF EACH OTHER

SHIM AS REQUIRED - AT LEAST ONE OF THESE SHIMS MUST BE USED AT EACH BOLT.

.030 THICK
.060 THICK
.120 THICK

SCREW (4)
[20-28 LB-FT]

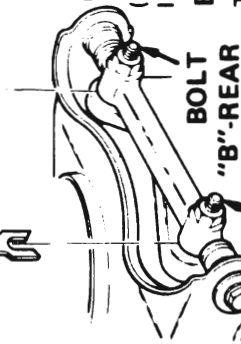

BOLT "A"-FRONT

VIEW A

INSTALL PIN HEAD TIGHT IN NUT SLOT & BEND APPROX AS SHOWN, AT BOTH UPPER & LOWER BALL STUDS.

AXIS OF COTTER PIN HOLES IN JOINT STUDS SHOULD BE LOCATED APPROX PARALLEL TO CAR WITH FRONT WHEELS STRAIGHT AHEAD.

VIEW B

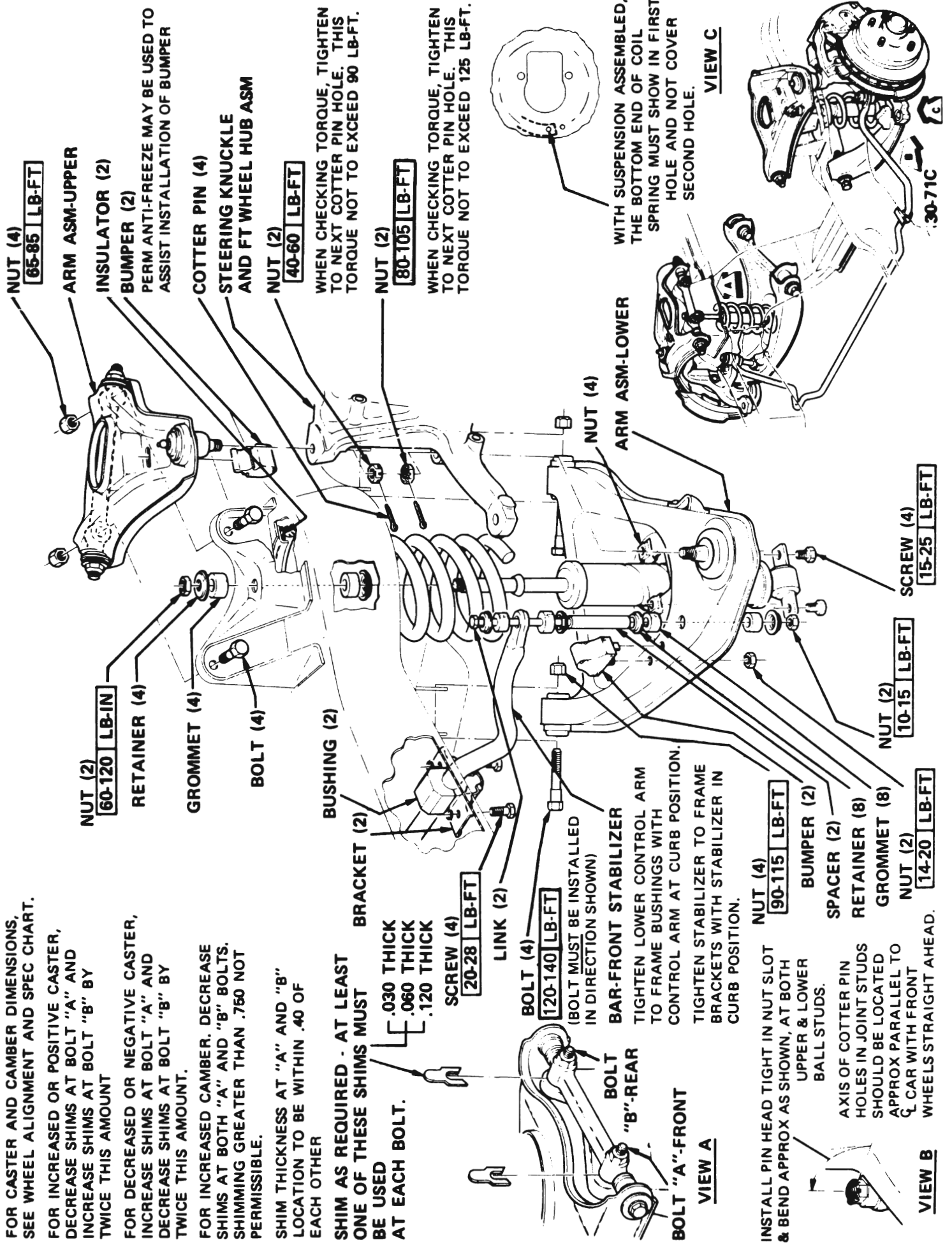

NUT (4)
[65-85 LB-FT]

ARM ASM-UPPER

INSULATOR (2)

BUMPER (2)

PERM ANTI-FREEZE MAY BE USED TO ASSIST INSTALLATION OF BUMPER

COTTER PIN (4)

STEERING KNUCKLE AND FT WHEEL HUB ASM

NUT (2)
[40-60 LB-FT]

WHEN CHECKING TORQUE, TIGHTEN TO NEXT COTTER PIN HOLE. THIS TORQUE NOT TO EXCEED 90 LB-FT.

NUT (2)
[80-105 LB-FT]

WHEN CHECKING TORQUE, TIGHTEN TO NEXT COTTER PIN HOLE. THIS TORQUE NOT TO EXCEED 125 LB-FT.

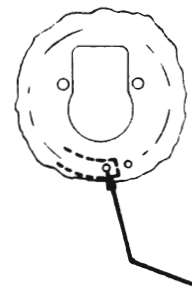

WITH SUSPENSION ASSEMBLED, THE BOTTOM END OF COIL SPRING MUST SHOW IN FIRST HOLE AND NOT COVER SECOND HOLE.

VIEW C

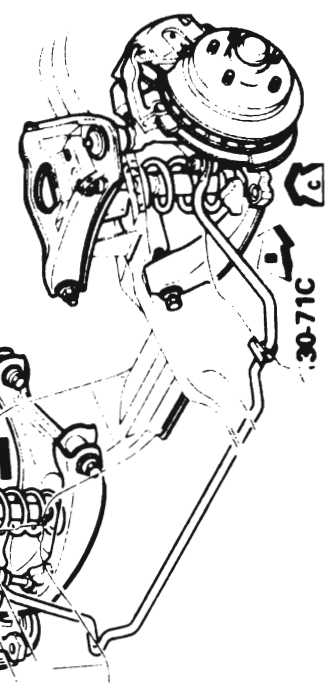

NUT (2)
[60-120 LB-IN]

RETAINER (4)

GROMMET (4)

BOLT (4)

BUSHING (2)

BRACKET (2)

LINK (2)

BOLT (4)
[120-140 LB-FT]

(BOLT MUST BE INSTALLED IN DIRECTION SHOWN)

BAR-FRONT STABILIZER

TIGHTEN LOWER CONTROL ARM TO FRAME BUSHINGS WITH CONTROL ARM AT CURB POSITION.

TIGHTEN STABILIZER TO FRAME BRACKETS WITH STABILIZER IN CURB POSITION.

NUT (4)
[90-115 LB-FT]

BUMPER (2)

SPACER (2)

RETAINER (8)

GROMMET (8)

NUT (2)
[14-20 LB-FT]

SCREW (4)
[15-25 LB-FT]

NUT (2)
[10-15 LB-FT]

ARM ASM-LOWER

Figure 30-40 Front Suspension Details

Front Suspension Alignment Chart 1972 4L-4N-4R-4P-4U-4V-4Y Series Curb Load

Measured Caster (Degrees)

		+2½°	+2¼°	+2°	+1¾°	+1½°	+1¼°	+1°	+¾°	+½°	+¼°	0°	-¼°	-½°
Measured Camber (Degrees)	+1¾°	F +0.36	+0.36	+0.33	+0.33	+0.30	+0.30	+0.27	+0.27	+0.27	+0.24	+0.24	+0.21	+0.21
	R	+0.12	+0.15	+0.18	+0.21	+0.24	+0.27	+0.30	+0.33	+0.33	+0.36	+0.39	+0.42	+0.45
	+1½°	F +0.33	+0.30	+0.30	+0.27	+0.27	+0.24	+0.24	+0.21	+0.21	+0.21	+0.18	+0.18	+0.15
	R	+0.09	+0.09	+0.12	+0.15	+0.18	+0.21	+0.24	+0.27	+0.30	+0.33	+0.36	+0.39	+0.42
	+1¼°	F +0.27	+0.24	+0.24	+0.24	+0.21	+0.21	+0.18	+0.18	+0.15	+0.15	+0.15	+0.12	+0.12
	R	+0.03	+0.06	+0.09	+0.12	+0.15	+0.15	+0.18	+0.21	+0.24	+0.27	+0.30	+0.33	+0.36
	+1°	F +0.21	+0.21	+0.18	+0.18	+0.18	+0.15	+0.15	+0.12	+0.12	+0.09	+0.09	+0.09	+0.06
	R	-0.03	0	+0.03	+0.06	+0.09	+0.12	+0.15	+0.18	+0.21	+0.24	+0.27	+0.30	+0.33
	+¾°	F +0.18	+0.15	+0.15	+0.12	+0.12	+0.12	+0.09	+0.09	+0.06	+0.06	+0.06	+0.03	+0.03
	R	-0.06	-0.03	0	0	+0.03	+0.06	+0.09	+0.12	+0.15	+0.18	+0.18	+0.24	+0.30
	+½°	F +0.12	+0.12	+0.09	+0.09	+0.06	+0.06	+0.06	+0.03	+0.03	0	0	0	-0.03
	R	-0.12	-0.06	-0.06	-0.03	0	+0.03	+0.06	+0.09	+0.09	+0.12	+0.15	+0.18	+0.21
	+¼°	F +0.09	+0.06	+0.06	+0.03	+0.03	0	0	0	-0.03	-0.03	-0.06	-0.06	-0.06
	R	-0.15	-0.12	-0.12	-0.09	-0.06	-0.03	0	+0.03	+0.06	+0.09	+0.12	+0.15	+0.18
	0°	F +0.03	0	0	-0.03	-0.03	-0.03	-0.06	-0.06	-0.06	-0.09	-0.09	-0.12	-0.12
	R	-0.21	-0.18	-0.15	-0.12	-0.09	-0.06	-0.06	-0.03	0	+0.03	+0.06	+0.09	+0.12
	-¼°	F 0	-0.03	-0.03	-0.06	-0.06	-0.09	-0.09	-0.12	-0.12	-0.12	-0.15	-0.15	-0.15
	R	-0.24	-0.24	-0.21	-0.18	-0.15	-0.12	-0.09	-0.06	-0.03	0	+0.03	+0.06	+0.09
	-½°	F -0.06	-0.06	-0.09	-0.09	-0.12	-0.12	-0.15	-0.15	-0.15	-0.18	-0.18	-0.21	-0.21
	R	-0.30	-0.27	-0.24	-0.21	-0.21	-0.18	-0.15	-0.12	-0.09	-0.06	-0.03	0	+0.03
	-¾°	F -0.12	-0.12	-0.12	-0.15	-0.15	-0.18	-0.18	-0.21	-0.21	-0.21	-0.24	-0.24	-0.27
	R	-0.36	-0.33	-0.30	-0.27	-0.27	-0.24	-0.21	-0.18	-0.15	-0.12	-0.09	-0.06	-0.03
	-1°	F -0.15	-0.18	-0.18	-0.18	-0.21	-0.21	-0.24	-0.24	-0.27	-0.27	-0.27	-0.30	-0.03
	R	-0.39	-0.36	-0.33	-0.33	-0.30	-0.27	-0.24	-0.21	-0.18	-0.15	-0.12	-0.09	-0.06
	-1¼°	F -0.21	-0.21	-0.24	-0.24	-0.24	-0.27	-0.27	-0.30	-0.30	-0.33	-0.33	-0.33	-0.36
	R	-0.45	-0.42	-0.39	-0.36	-0.33	-0.30	-0.27	-0.27	-0.24	-0.21	-0.18	-0.15	-0.12

F - Shim pack thickness change required at front Bolt (inches)

+ Means shim addition

R - Shim pack thickness change required at rear bolt (inches)

- Means shim removal

FRONT END ALIGNMENT

Satisfactory vehicle operation may occur over a wide range of front end (wheel) alignment settings. Nevertheless, should settings vary beyond certain tolerances, readjustment of alignment is advisable. The specifications stated in Chart "A" of this manual should be used by owners, dealers, and repairmen as guidelines in vehicle diagnosis, either for repairs under the new vehicle warranty or for maintenance service at customers' requests. These specifications provide an acceptable all-around operating range in that they prevent abnormal tire wear caused by wheel alignment.

WHEEL ALIGNMENT SPECIFICATIONS

	CHART A		CHART B	
	Specifications for Diagnosis for Warranty Repairs Or Customer Paid Service		Specifications for Resetting Alignment	
	4D-4F-4G-4H SERIES	4L-4N-4R-4P-4U- 4V-4Y SERIES	4D-4F-4G-4H SERIES	4L-4N-4R-4P-4U- 4V-4Y SERIES
Caster	-1 1/2° to +1/2°	+2° to 0°	-1/2° (±1/2°)	+1° (±1/2°)
Camber	+1 1/4° to -1/4°	+1° to -1/2°	+1/2° (±1/2°)	+1/2° (±1/2°)
Toe-In	1/16" toe-in to 5/16" toe-in		3/16" toe-in (±1/16")	
Cross Caster	No More Than 1° Side to Side Variation		No More Than 1/2° Side to Side Variation	
Cross Camber	No More Than 1° Side to Side Variation		No More Than 1/2° Side to Side Variation	

Governmental Periodic Motor Vehicle Inspection programs usually include wheel alignment among items that are inspected. To provide useful information for such inspections, the tolerances shown in Chart "C" are applicable and well within the range of safe vehicle operation.

MOTOR VEHICLE INSPECTION STATION TOLERANCES

	CHART C	
	4D-4F-4G-4H SERIES	4L-4N-4R-4P-4U- 4V-4Y SERIES
Caster	+ 1 1/2° to -2 1/2°	+3° to -1°
Camber	+2° to -1°	+1 3/4° to -1 1/4°
Toe-In	3/16" toe-out to 9/16" toe-in	

In the event the actual settings are beyond the specifications set forth in Chart "A" or "C" (whichever is applicable), or whenever for other reasons the alignment is being reset, Buick recommends that the specifications given in Chart "B" of the aforesaid applicable chart be used.

30-63B

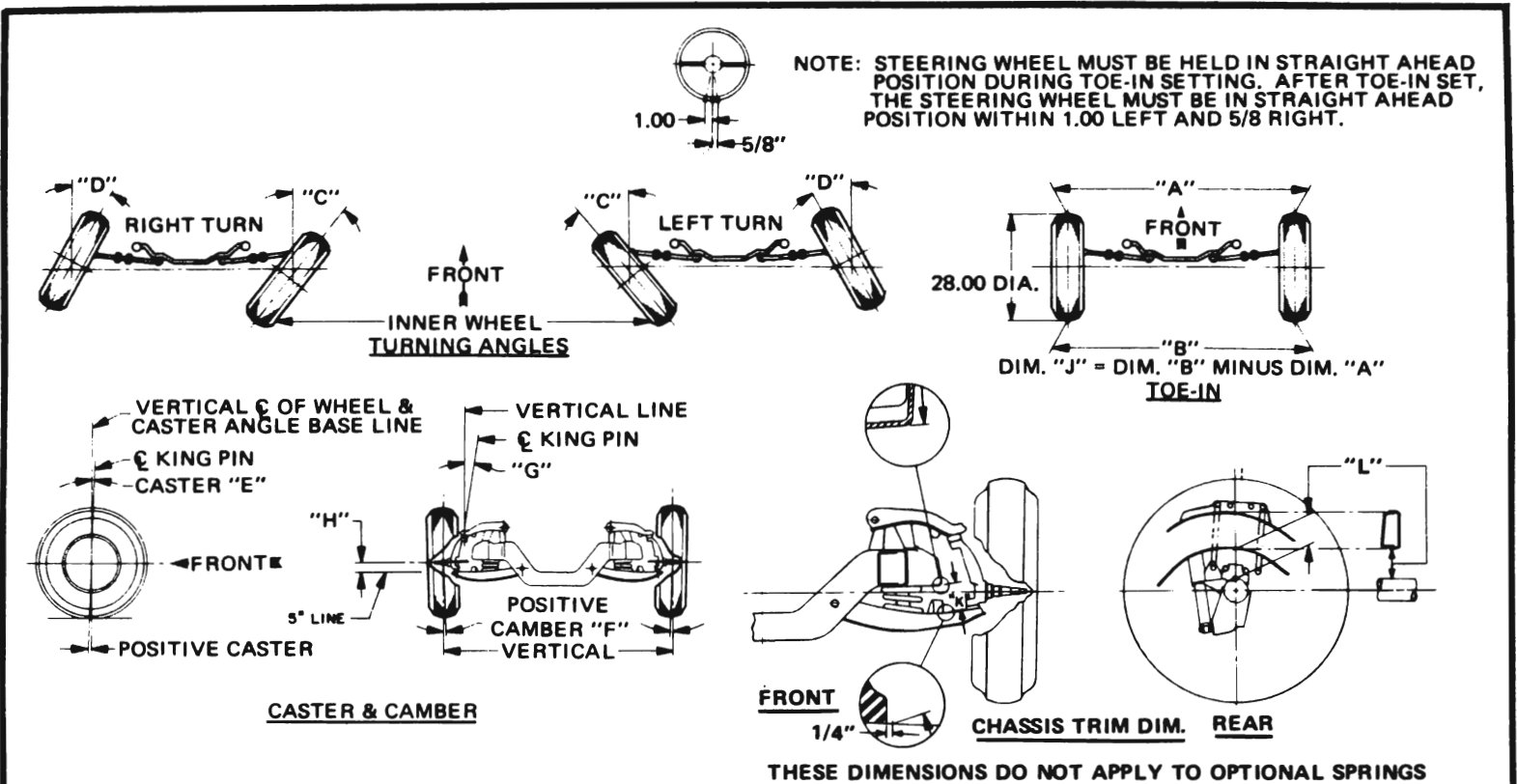

MODEL	FULL TURN INNER WHEEL "C" CURB	FULL TURN OUTER WHEEL "D" CURB	OUTER WHEEL ANGLE WITH INNER WHEEL AT 20°	STEERING AXIS ANGLE "G" AT 0° CAMBER	CHASSIS TRIM DIM. CURB WEIGHT	
					FRONT "K" \pm 3/16"	REAR "L" \pm 1/4"
4L39 4L57 4L69 4N39 4N57 4N67 4N69	35 1/4°	32 1/4°	18 1/2°	10 1/2°	4 1/6"	5 9/16"
4R35 4R45	34 3/4°	31 1/2°	18 1/2°	10 1/2°	4 3/4"	6"
4P39 4P47 4P67	35 1/4°	32 1/4°	18 1/2°	10 1/2°	4 1/16"	5 9/16"
4U37 4U39 4V37 4V39	35 1/4°	32 1/4°	18 1/2°	10 1/2°	4 1/8"	5 9/16"
4Y87	35 1/4°	32 1/4°	18 1/2°	10 1/2°	4 1/6"	4 7/8"

Figure 30-43 Wheel Alignment and Chassis Trim Chart 4L-4N-4R-4P-4U-4V-4Y Series



J-9552



J-9519-01

- J 9519-01 LOWER CONTROL BALL JOINT REMOVER AND REPLACER SET
- J 9552 FRONT COIL SPRING COMPRESSOR

Figure 30-44 Special Tools