

SECTION B**HEATER SYSTEM****4L-4N-4R-4P-4U-4V-4Y SERIES****CONTENTS**

Division	Subject	Page No.
I	TROUBLE DIAGNOSIS: Heater-Defroster Trouble Diagnosis	12-14
II	DESCRIPTION AND OPERATION: Description of System	12-14
	Operation of Controls	12-15
III	ADJUSTMENTS AND MINOR SERVICE: Adjustment of the Temperature Selector Lever and Temperature Door	12-16
IV	REMOVAL AND INSTALLATION: Removal and Installation of Heater Control Assembly	12-16
	Removal and Installation of Blower Motor or Blower Motor and Air Inlet Assembly	12-16
	Removal and Installation of Heater Assembly or Heater Core	12-17
V	OVERHAUL AND MAJOR SERVICE: (Not Applicable)	
VI	SPECIFICATIONS: General Specifications	12-17

DIVISION I**TROUBLE DIAGNOSIS****12-10 HEATER-DEFROSTER TROUBLE DIAGNOSIS**

Condition	Possible Cause and Correction
Blower Motor Inoperative	<ol style="list-style-type: none"> 1. Check fuse. 2. Check for defective heater- blower switch. 3. Check for defective blower resistor assembly. 4. Check for loose connectors or broken wires. 5. Check thermal delay switch or relay.
Insufficient Heating	<ol style="list-style-type: none"> 1. Check operation of purge door and temperature door. 2. Check for air leaks around sealing edges of components. 3. Check for dirt in engine thermostat. 4. Check for sufficient coolant. 5. Check for dislodged diaphragm in flow control valve (4R-4P-4U-4V Series). 6. Check for air leaks through dash, around doors, windows, around purge opening, etc. 7. Check for proper operation of water pump.
Inadequate Defrosting	<ol style="list-style-type: none"> 1. Check for proper connection and adjustment of bowden cable to defroster and heater. 2. Check for air leaks and for sufficient coolant. 3. Check for loose or disconnected defroster air duct hoses and for position of defroster duct and instrument panel openings. Twist tabs provide positive position if properly installed.

DIVISION II**DESCRIPTION AND OPERATION****12-11 DESCRIPTION OF SYSTEM**

The heater system is an air mix type system in which outside air is heated and then mixed in varying amounts with cooler outside air to attain the desired air temperature. The system consists basically of three parts: (1) the blower and air inlet assembly, (2) the heater assembly and (3) the heater control assembly (see Figure 12-9). The operation of the system is as follows:

1. **Blower and Air Inlet Assembly**-The blower and air inlet assembly draws outside air through the outside air inlet grille located forward of the windshield reveal molding and channels the air into the heater assembly.

The operation of the blower motor is controlled by a FAN switch on the heater control. The motor is connected in series with the three position FAN switch and also the blower resistor assembly. See Figure 12-9. A 25 amp fuse, located in the fuse block, is in series between the blower motor and the battery.

To insure adequate ventilation of the passenger compartment, the heater blower fan is on continuously, after engine coolant temperature reaches approximately 120 degrees F, and when the FAN switch is in the LO position. The fan will blow air from the purge opening under the passenger side of dash at whatever fan speed is selected, as long as the selector lever is in the OFF position. When the selector lever is in the HEAT position and the blower switch is in the LO position, the blower fan will not come on before the engine coolant temperature reaches approximately 120 degrees F. However, if the blower switch is in the MEDIUM or HI position, the blower

fan will run immediately, regardless of engine coolant temperature.

Engine coolant temperature is sensed by a thermal switch, which is installed in the right (passenger side) cylinder head. When the coolant temperature reaches approximately 120 degrees F, the switch opens and stops current flow through the coil of the delay relay, allowing the points to snap closed. When the delay relay is closed, current can then flow to the blower motor.

2. Heater Assembly - The heater assembly (see Figure 12-11) houses the heater core and the doors necessary to control mixing and channeling of the air. Air entering the heater assembly divides into two channels: (1) through the heater core and (2) through a by-pass around the heater core. The ratio of the mixture of heated to unheated air is controlled by the temperature door. A purge inlet door initiates the air flow through the heater assembly. A defroster door controls the amount of air directed through the defroster outlets. The defroster door may be positioned to direct nearly all air to the defroster outlet or nearly all air to the floor outlet and may be varied to provide intermediate proportions as desired.

The heater core, located in the heater assembly, has

water flowing through it at all times. The water flow begins at the front of the intake manifold and flows to the lower (inlet) port of the heater core, thru the heater core, out the upper (outlet) port of the heater core and to the suction port of the water pump. See Figure 12-15.

The heater assembly has fixed vane outlets to distribute air evenly throughout the passenger compartment.

3. Heater Control Assembly - The heater control assembly (see Figure 12-14) consists of three controls, namely the TEMPERATURE lever, SELECTOR lever and FAN switch.

12-12 OPERATION OF CONTROLS

The TEMPERATURE lever is connected by a control wire to the temperature door on the heater assembly, and regulates the ratio of mixture between heated and unheated air, hence the temperature of the air. When the TEMPERATURE lever is positioned fully to the left, the temperature door is fully closed and prevents air flow through the heater core. When the TEMPERATURE lever is positioned midway in its range of travel, the temperature door is moved in proportion to allow more outside air to flow through

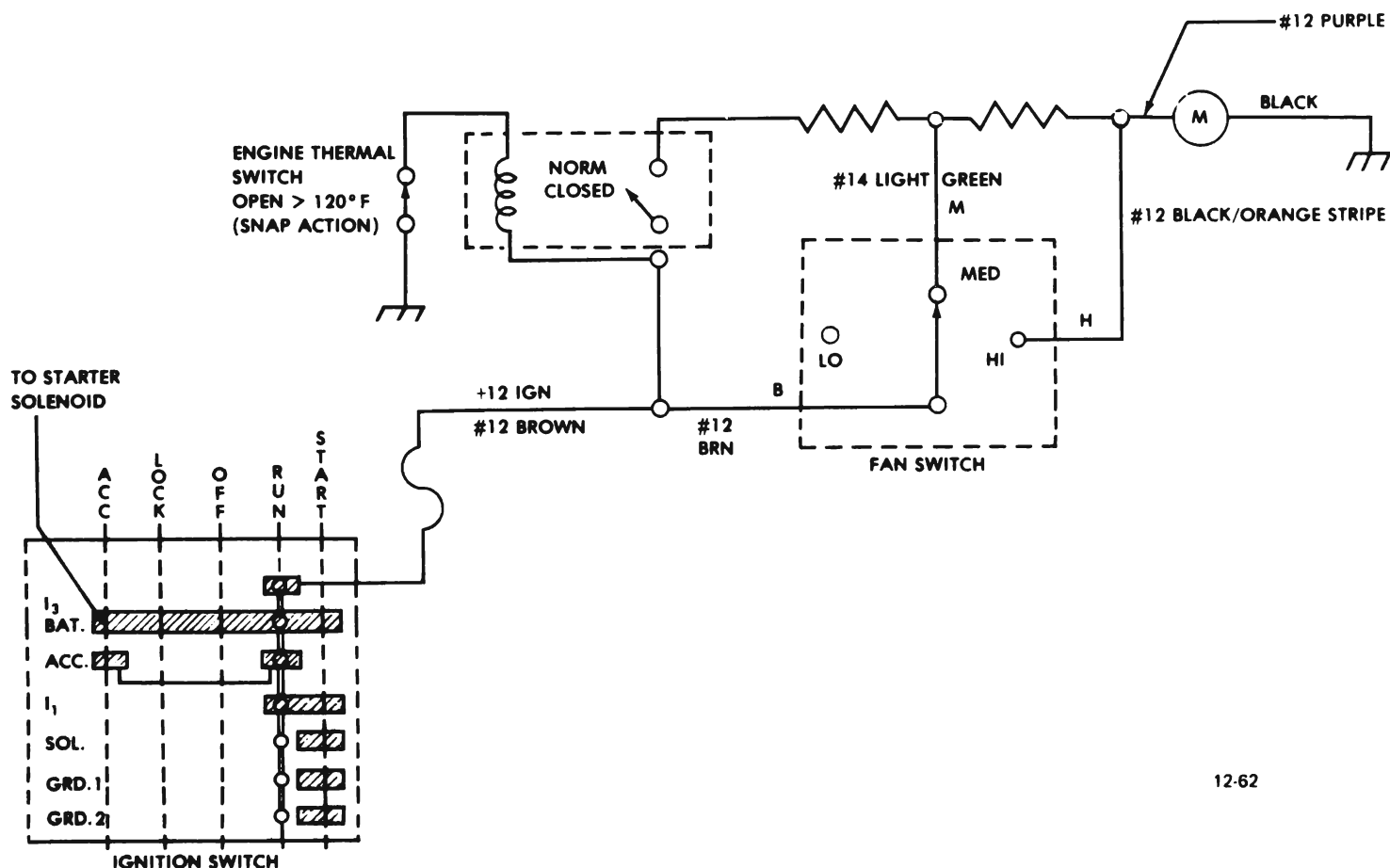

Figure 12-9 Heater System Wiring Diagram

the heater core and hence be warmed. When the TEMPERATURE lever is positioned fully to the right, the temperature door is fully open and directs all outside air through the heater core.

The SELECTOR lever of the heater control assembly regulates the positioning of two doors: the diverter air door and the defroster door. The SELECTOR lever has three positions: OFF, HTR and DEFROST. Positioning of the SELECTOR lever to the "OFF" position closes the diverter door and the defroster door. When the door is closed, all air is blocked from passing through the heater assembly and is emitted from the diverter opening under dash on the right side of car. When the SELECTOR lever is moved to the HTR position, the air door is fully opened. Air is permitted to pass through the heater assembly and is directed to the floor of the car. Moving of the SELECTOR lever to DEFROST position, opens the defroster door and directs the air to the defroster outlets.

The FAN switch operates a three position switch. A two resistor blower resistor assembly is connected in series between the blower motor and the switch, and serves to reduce the speed of the motor. When the FAN switch is positioned fully downward, the blower motor is LO. Movement of the switch upward provides LO, MEDIUM and HI blower speeds.

DIVISION III

ADJUSTMENTS AND MINOR SERVICE

12-13 ADJUSTMENT OF TEMPERATURE SELECTOR LEVER AND TEMPERATURE DOOR

The control cable should be adjusted when equal springback is not obtained at both ends of lever travel. This adjustment should also be made when the heater assembly has been removed or when the temperature door does not open sufficiently to permit maximum air flow.

To adjust, position the TEMPERATURE lever to the "COOL" position and rotate the control cable adjuster nut until equal springback is obtained at both ends of lever travel. See Figure 12-13.

DIVISION IV

REMOVAL AND INSTALLATION

12-14 REMOVAL AND INSTALLATION OF HEATER CONTROL ASSEMBLY

A. Removal

1. Disconnect battery.
2. Remove head light switch.
3. Remove lower dash trim.
4. Remove two (2) see-lights from trim plate.
5. Remove four (4) screws from control face.
6. Remove one (1) screw from under dash which connects heater control to instrument panel forward support.
7. Disconnect vacuum, electrical connectors, and Bowden wires.
8. Remove control assembly.

B. Installation

1. Install control assembly.
2. Connect bowden wires, electrical connectors, and vacuum connectors.
3. Install heater control to instrument panel forward support, securing with one (1) screw.
4. Install four (4) screws into control face.
5. Install two (2) see-lights into trim plate.
6. Install lower dash trim.
7. Install headlight switch.
8. Adjust temperature control lever as necessary (refer to paragraph 12-13).
9. Connect battery.

12-15 REMOVAL AND INSTALLATION OF BLOWER MOTOR OR BLOWER MOTOR AND AIR INLET ASSEMBLY

A. Removal

1. Support hood and loosen hood hinge from extension and plate assembly.
2. Remove extension and plate assembly.
3. (Blower Motor Only) Disconnect blower motor wire.

Remove screws securing blower motor to air inlet assembly.

(Blower Motor and Air Inlet Assembly) Disconnect blower motor wire. Remove four (4) nuts and two (2) screws securing blower and air inlet assembly to dash. See Figure 12-14.

4. Disconnect electrical connector from blower motor resistor.

B. Installation

1. Connect electrical connector to blower motor resistor.

2. (Blower Motor and Air Inlet Assembly) Install four (4) nuts and two (2) screws, securing blower and air inlet assembly to dash. Connect blower motor wire. See Figure 12-14.

(Blower Motor Only) Install screws, securing blower motor to air inlet assembly.

3. Install extension and plate assembly.

4. Install extension and plate assembly and tighten hood hinge.

5. Seal along mating surfaces between dash and air inlet assembly.

12-16 REMOVAL AND INSTALLATION OF HEATER ASSEMBLY OR HEATER CORE

A. Removal

1. Drain radiator and disconnect heater inlet and outlet hoses at dash. See Figure 12-15.

2. Disconnect control wires from defroster door and

vacuum hose diverter door actuator diaphragm and control cable from temperature door lever.

3. Remove four (4) nuts securing heater assembly to dash. See Figure 12-14.

4. Remove screw securing defroster outlet tab to heater assembly.

5. Work heater assembly rearward until studs clear dash and remove heater assembly.

B. Installation

1. Install heater assembly into dash.

2. Install defroster outlet tab to heater assembly, securing with a screw.

3. Install heater assembly to dash, securing with four (4) nuts. See Figure 12-14.

4. Install control cable to temperature door lever.

5. Install control wires from defroster door and vacuum hose diverter door actuator diaphragm.

6. Connect inlet and outlet hoses at dash and refill radiator. See Figure 12-15.

7. Seal along mating surfaces between dash and heater assembly.

8. Adjust temperature control cable as necessary (refer to paragraph 12-13).

DIVISION VI

SPECIFICATIONS

12-17 GENERAL SPECIFICATIONS

Recommended Coolant	Ethylene-Glycol Base
Thermostat Opening Temperature	190
Cooling System Capacity With Heater (Quarts)	
350-4L Series	13.2
455-4L-4N-4R-4P-4U-4V-4Y Series	18.7
Blower Motor Type	12 VDC
Blower Motor Fan	Squirrel Cage

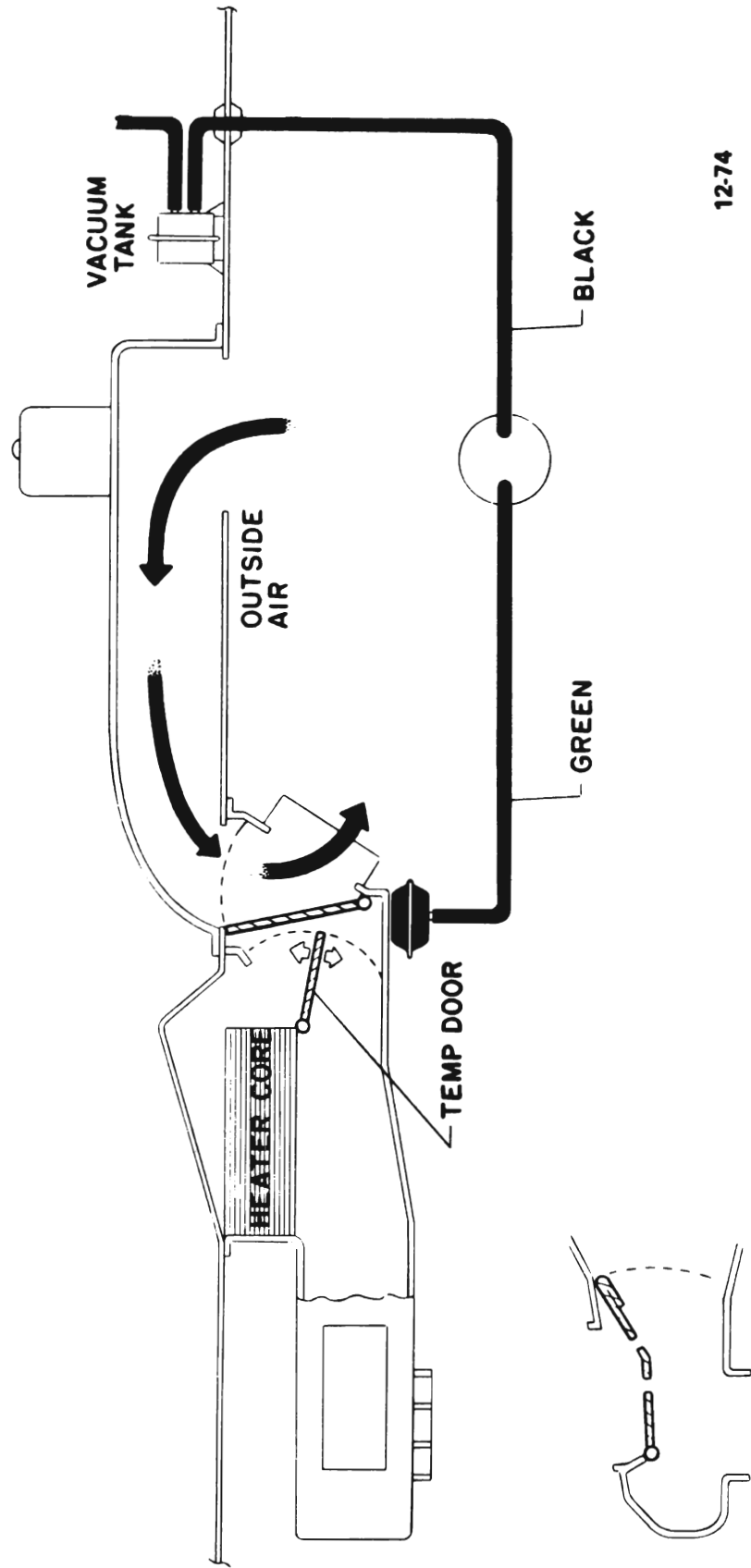
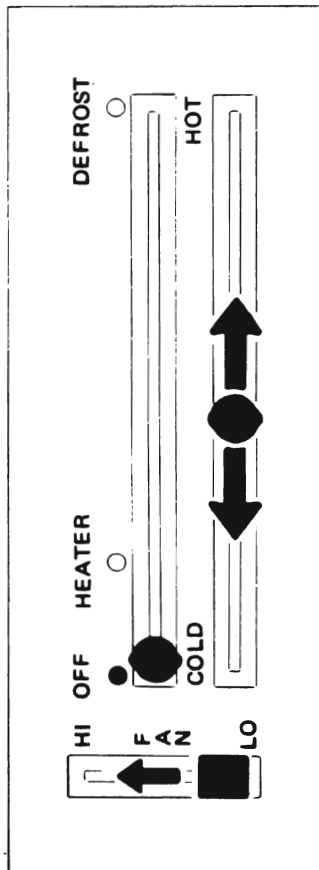

Figure 12-10 Heater System Air Flow - Off

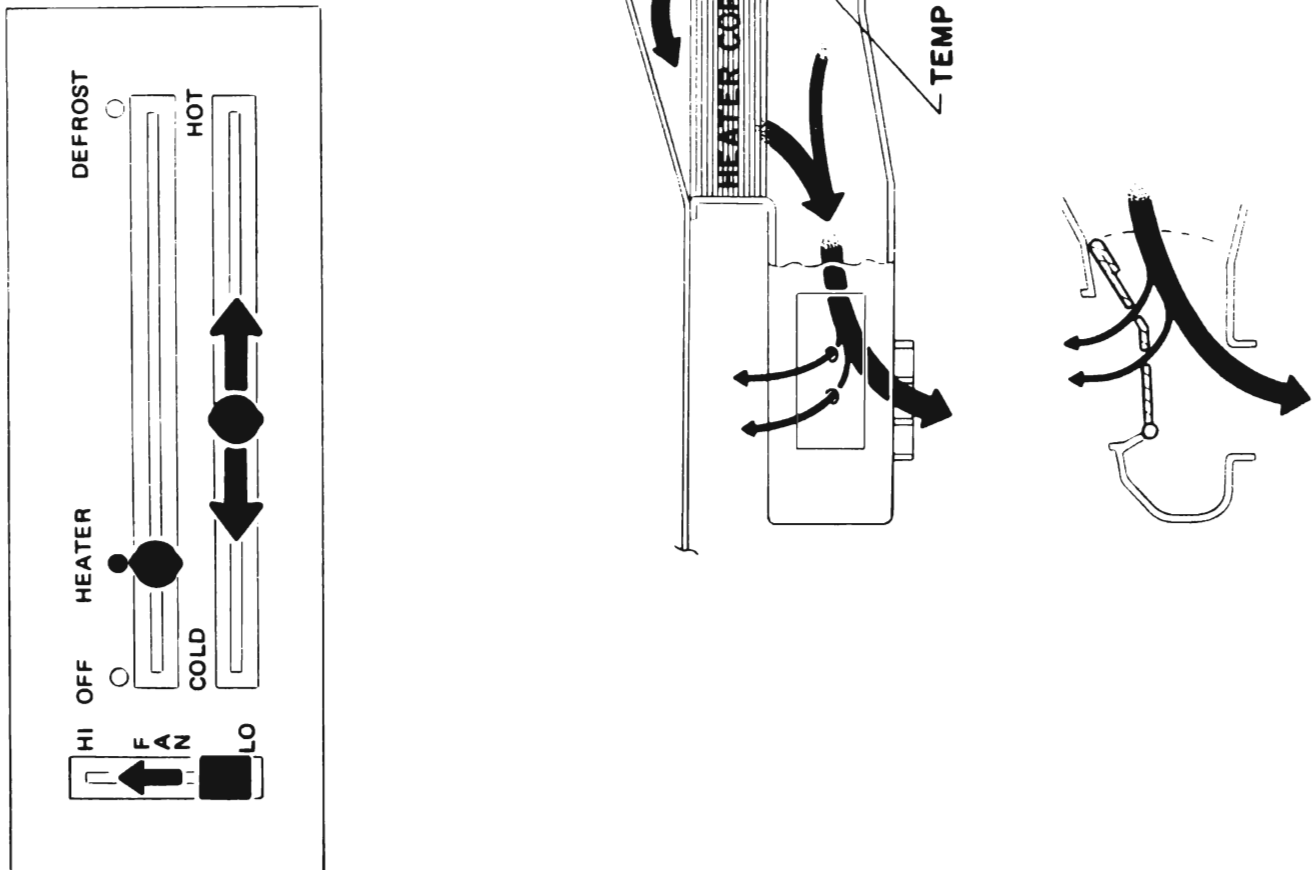

Figure 12-11 Heater System Air Flow - Heat

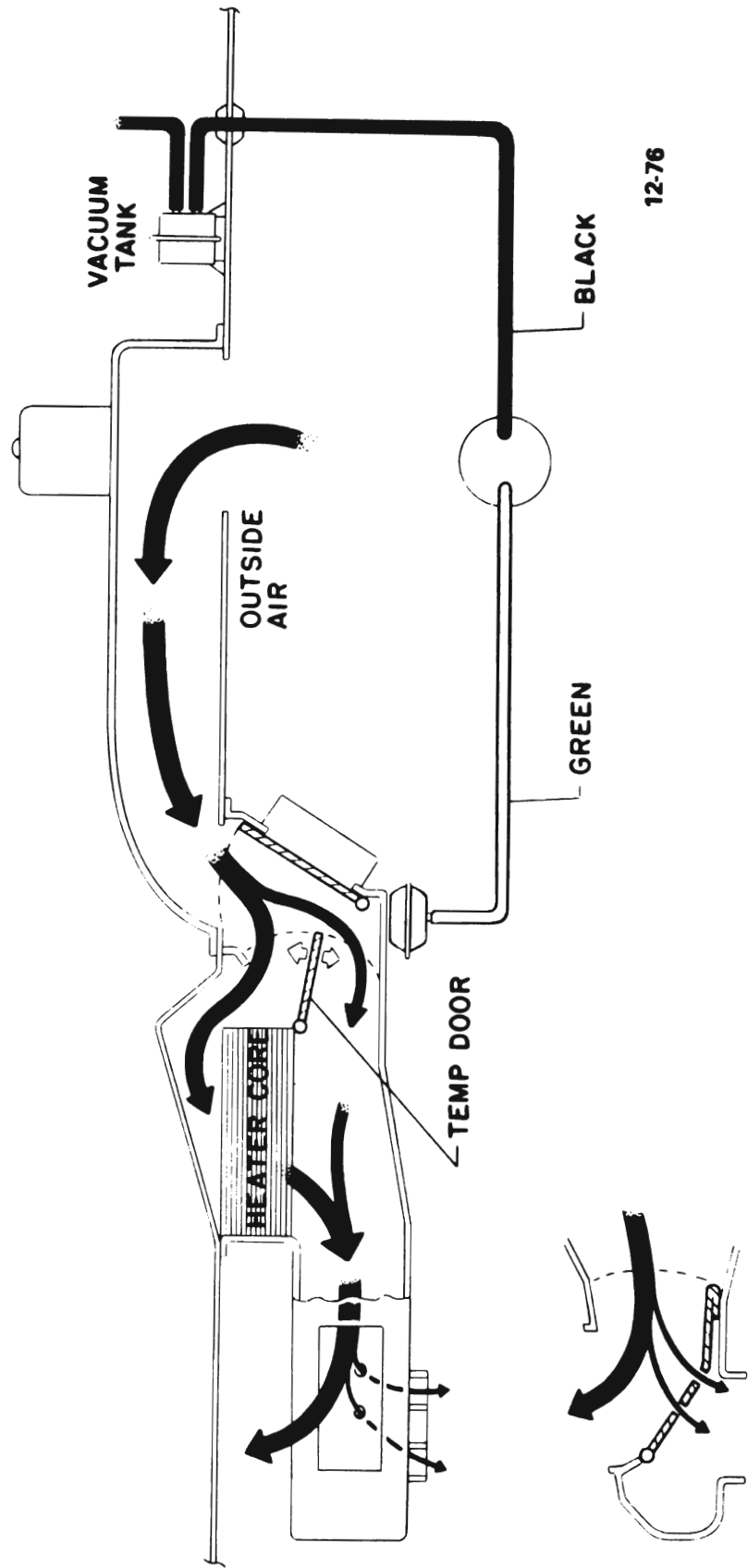
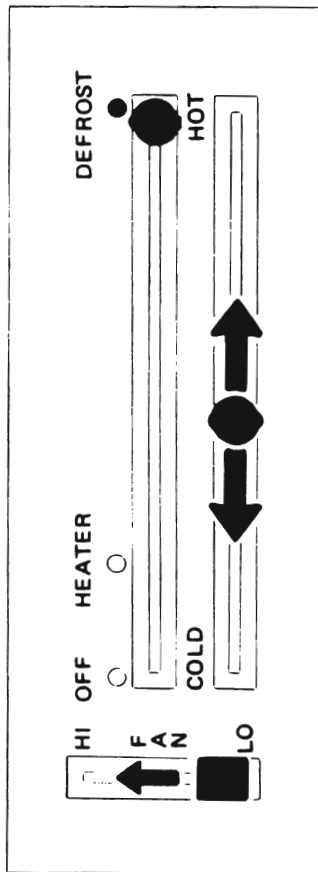

Figure 12-12 Heater System Air Flow - Defrost

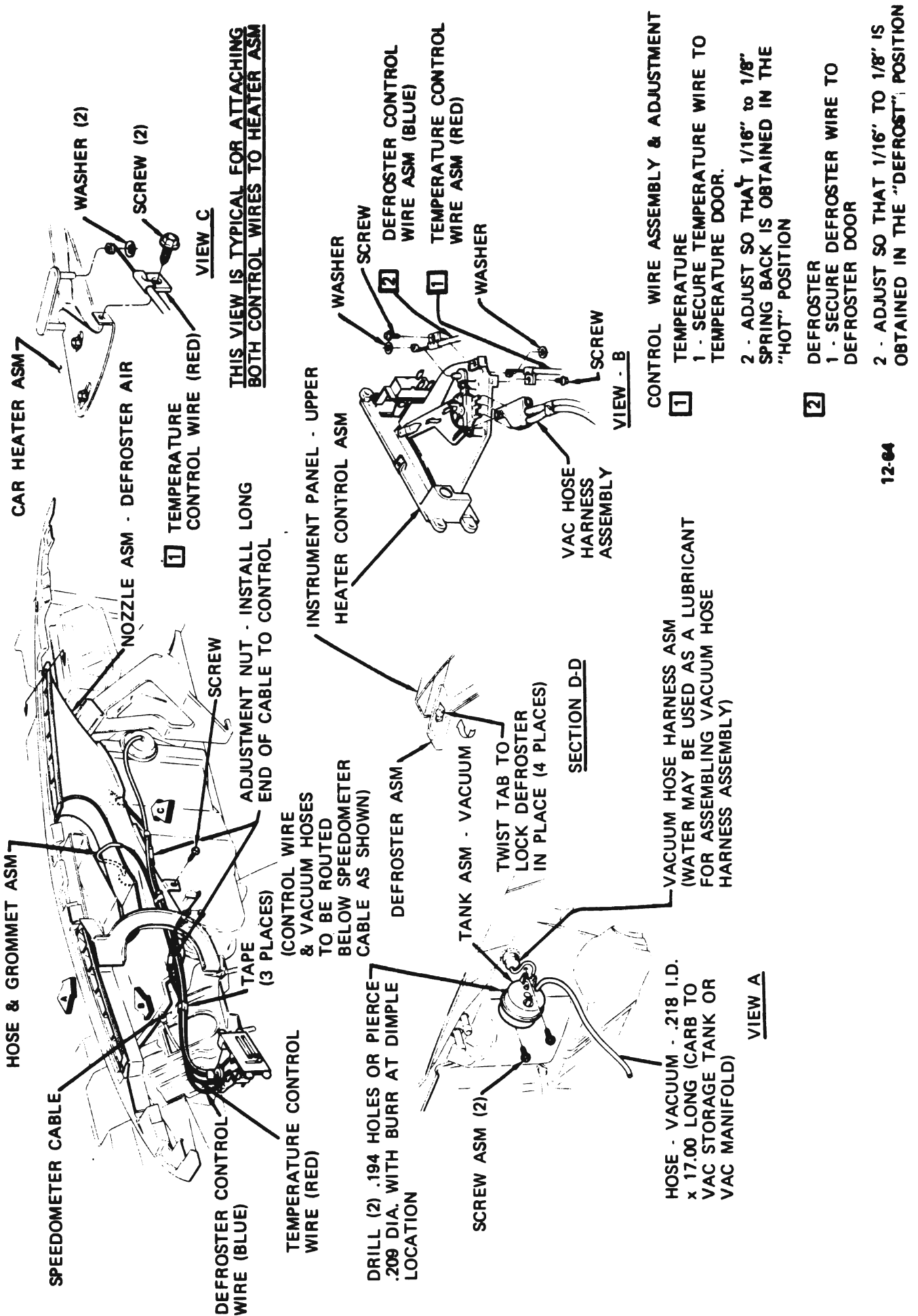
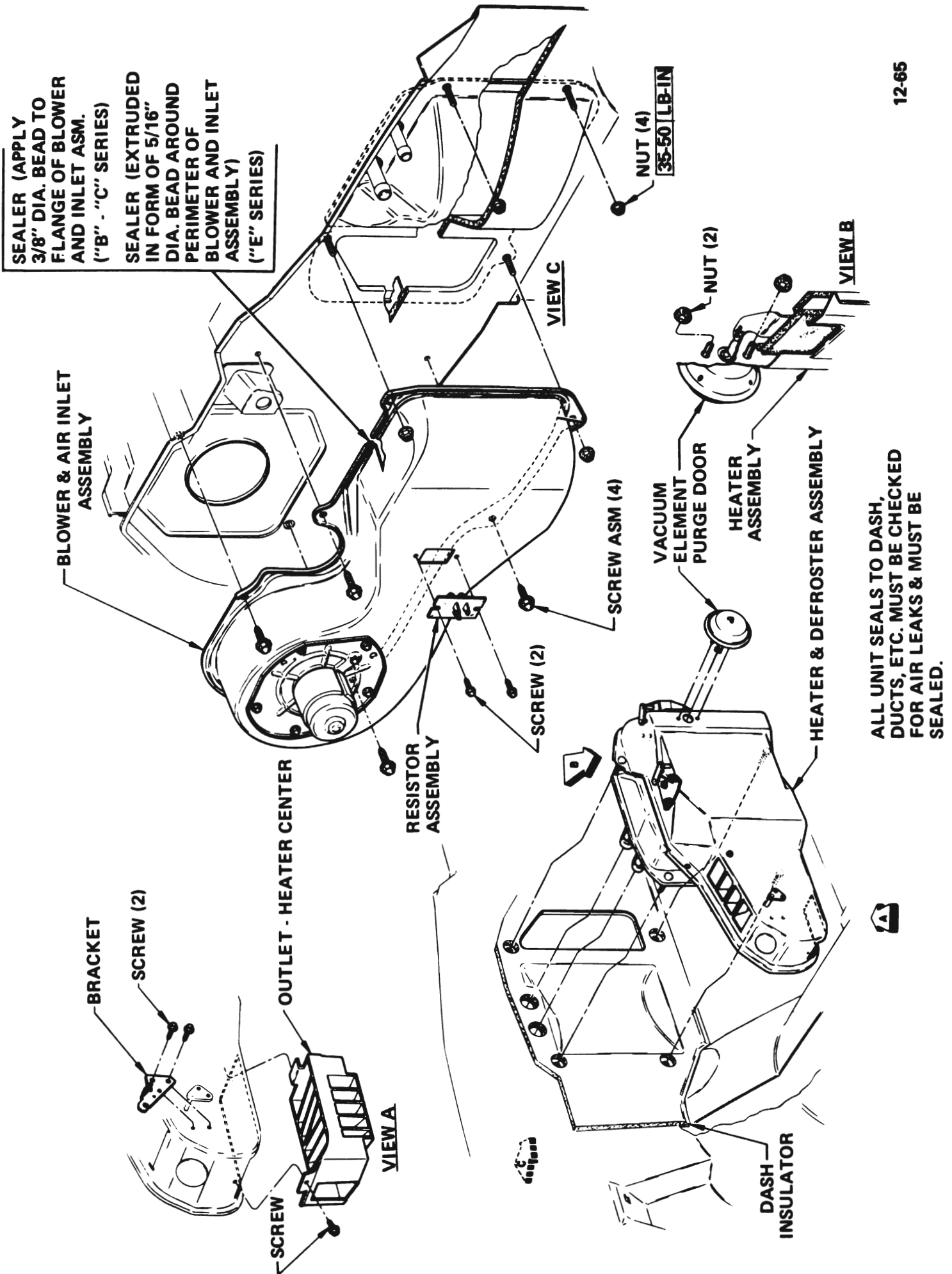
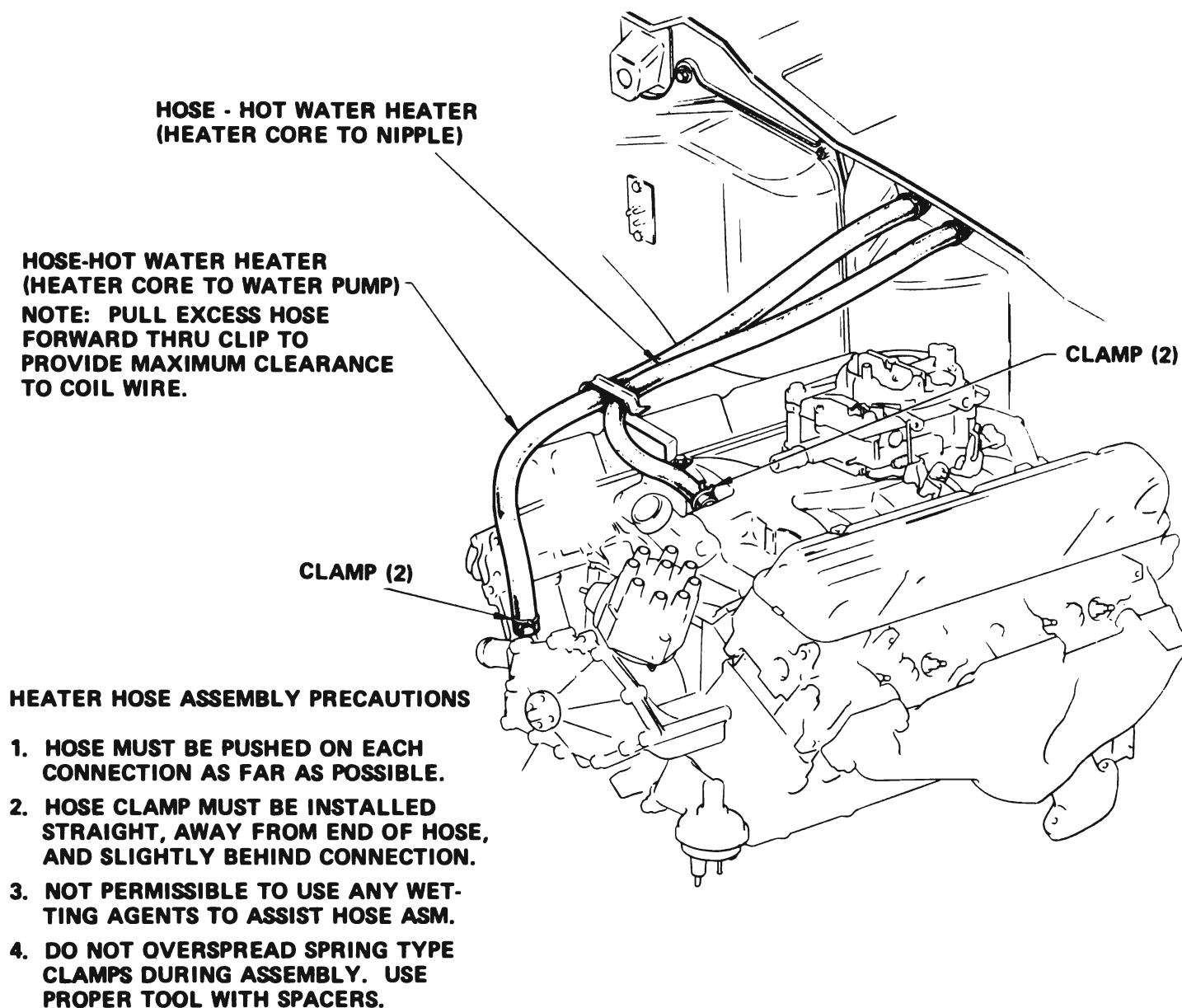

Figure 12-13 Heater and Defroster Vacuum Harness and Control Wires



ALL UNIT SEALS TO DASH, DUCTS, ETC. MUST BE CHECKED FOR AIR LEAKS & MUST BE SEALED.

Figure 12-14 Heater and Defroster Dash Units



12-66

Figure 12-15 Heater Hose (Water) Installation

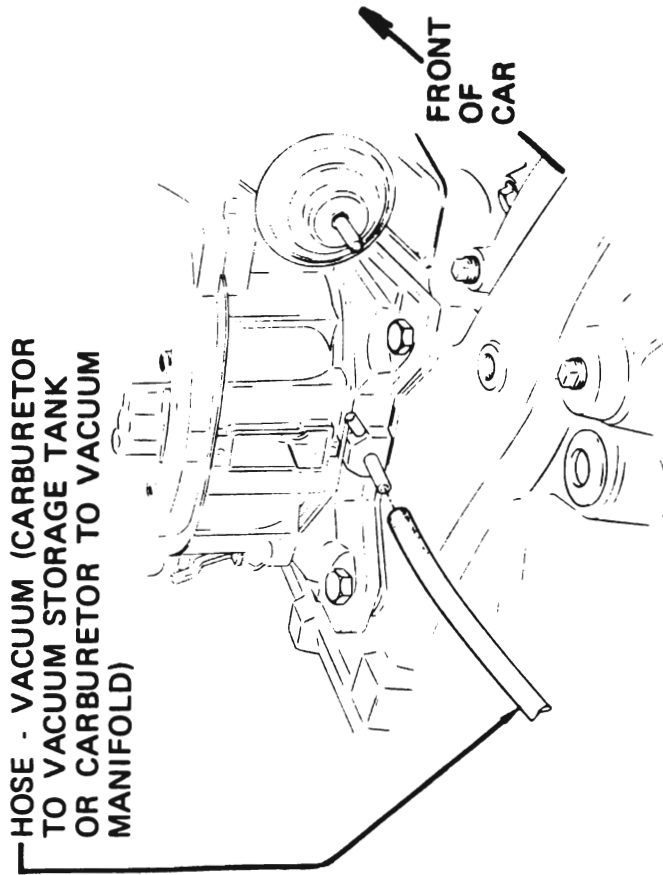

4 BARREL CARBURETOR

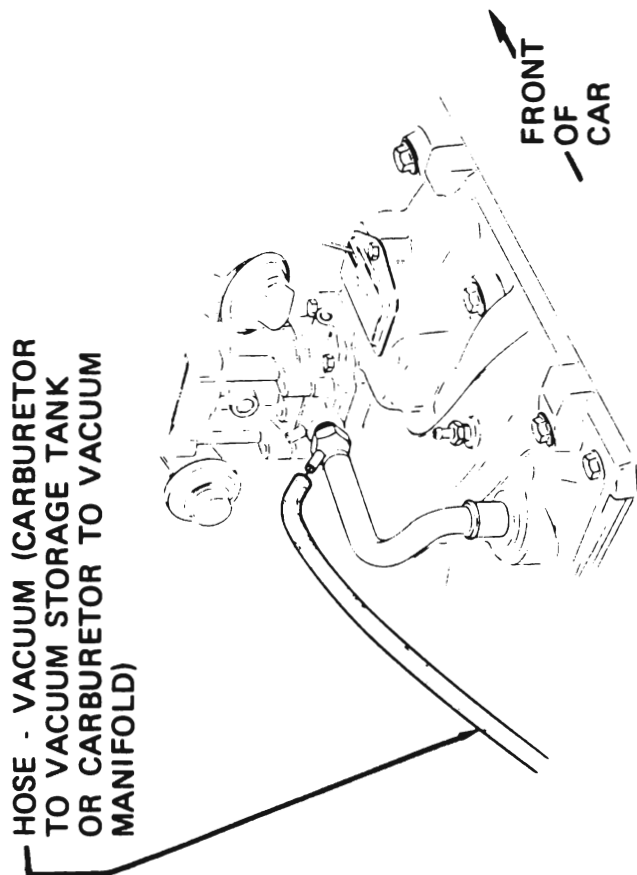

2 BARREL CARBURETOR

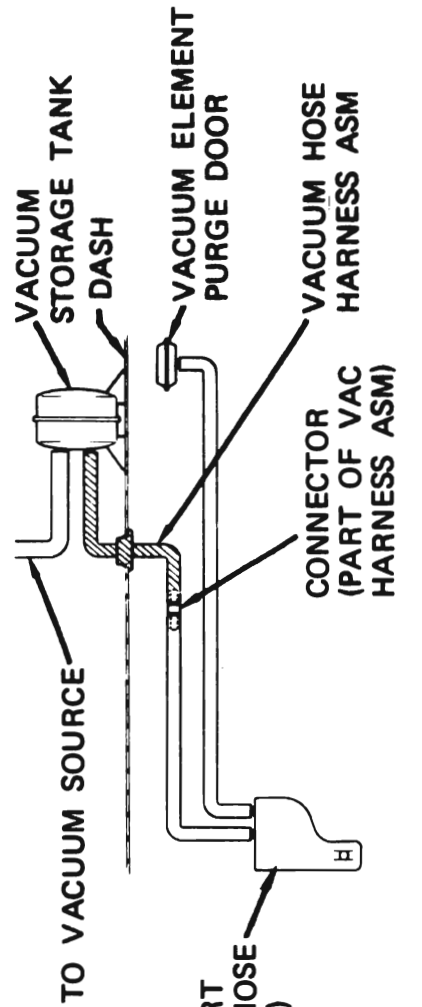

VACUUM SCHEMATIC

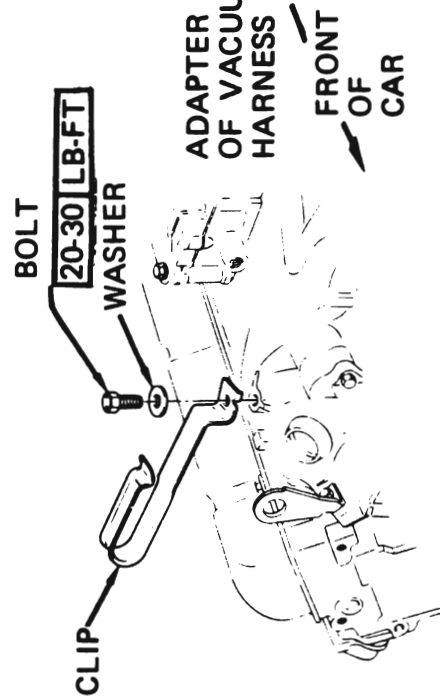
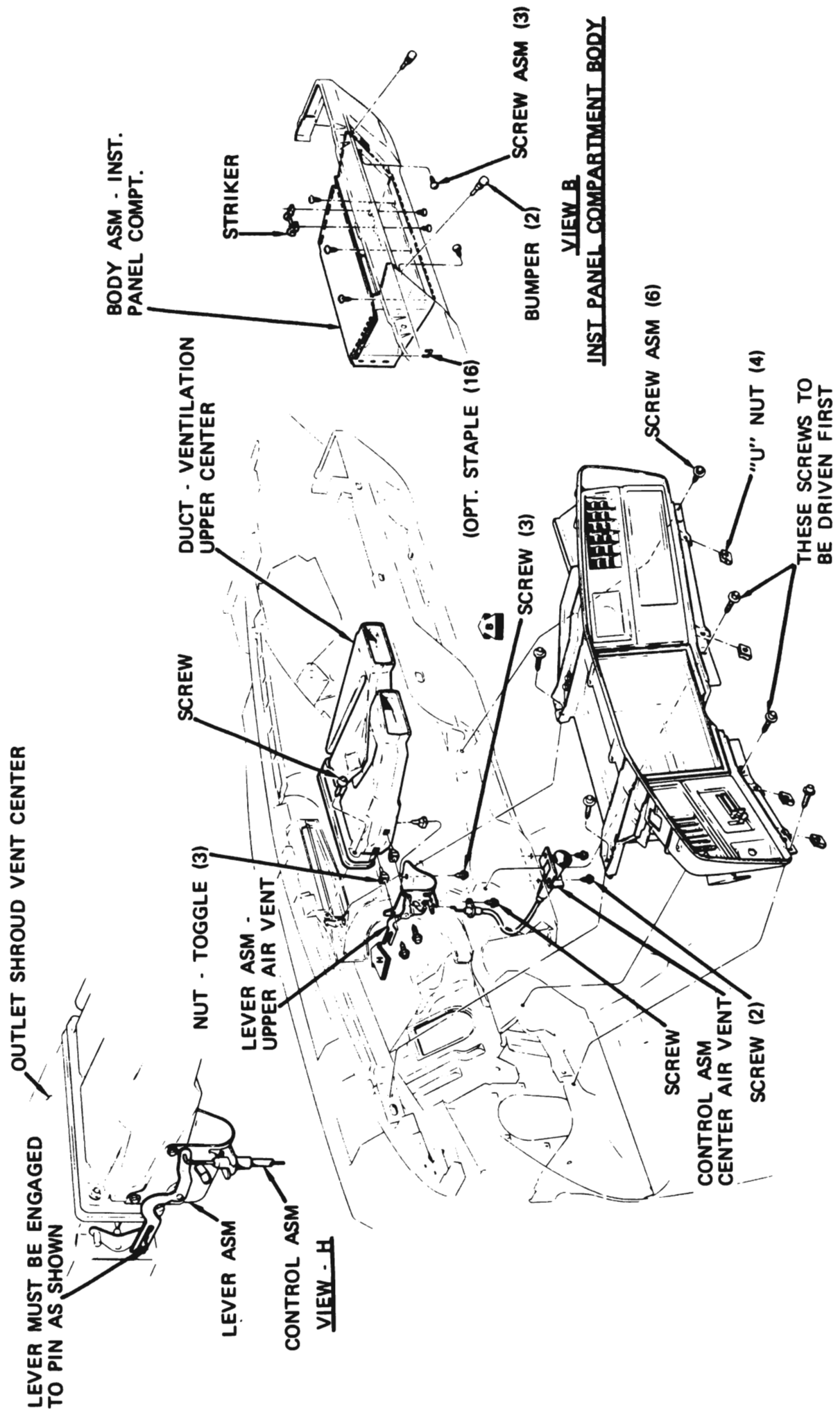

Figure 12-16 Heater Hose (Vacuum) Installation



12-68

Figure 12-17 Upper Ventilation Center Duct Assembly

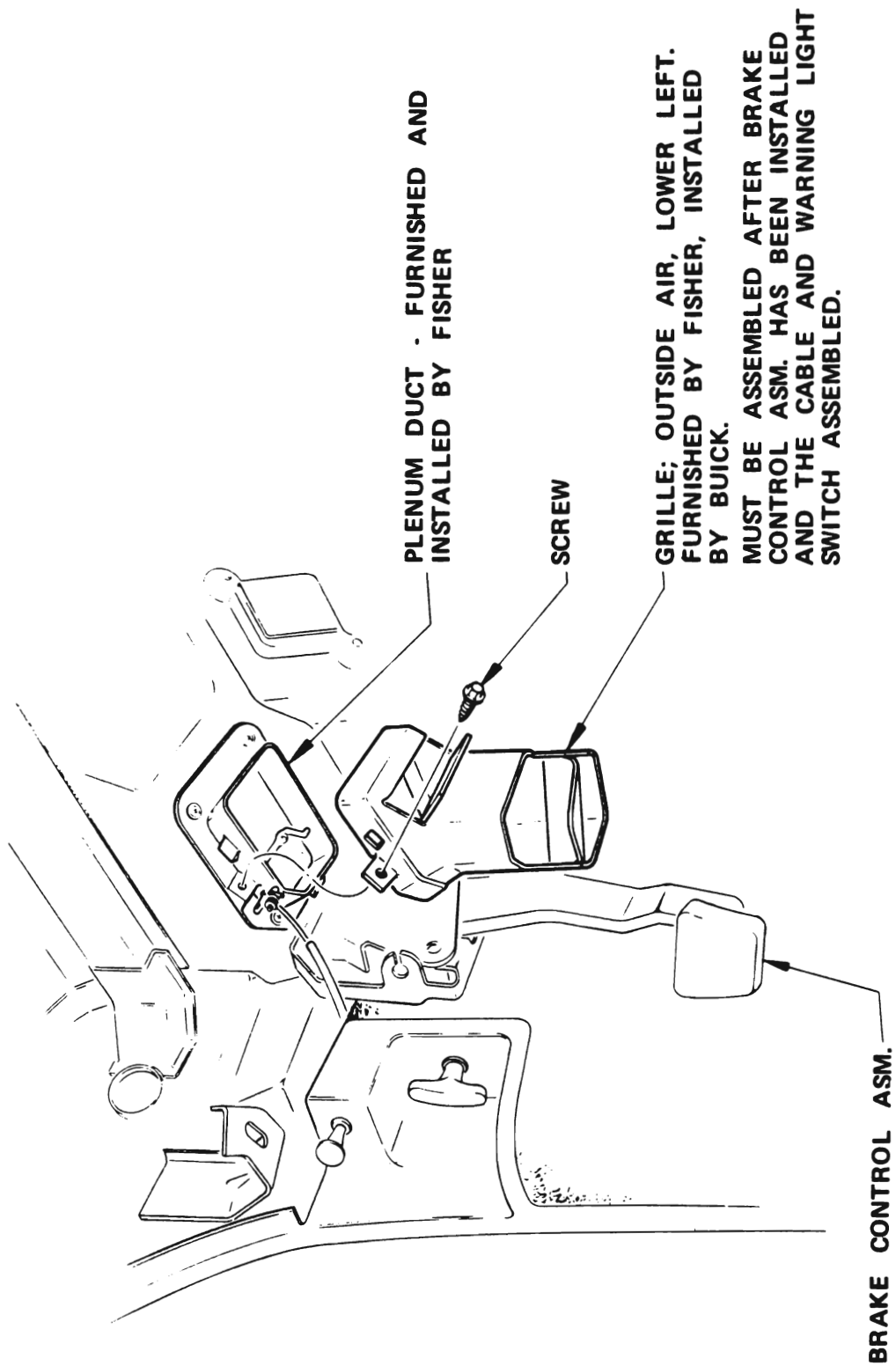

Figure 12-18 Instrument Panel Grille - Outside Air - Lower Left