

# SECTION A

## WHEELS AND TIRES

### ALL SERIES

#### CONTENTS

Division	Subject	Page No.
I	<b>TROUBLE DIAGNOSIS:</b>	
	Car Roughness and Vibration .....	100-2
	Improper Steering Action .....	100-6
	Wheel Tramp .....	100-8
	Abnormal Tire Wear .....	100-8
II	<b>DESCRIPTION AND OPERATION: (Not Applicable)</b>	
III	<b>ADJUSTMENTS AND MINOR SERVICE:</b>	
	Tire Service and Inspection .....	100-11
IV	<b>REMOVAL AND INSTALLATION: (Not Applicable)</b>	
V	<b>OVERHAUL AND MAJOR SERVICE: (Not Applicable)</b>	
VI	<b>SPECIFICATIONS:</b>	
	Bolt Torque Specifications .....	100-13
	Wheel and Tire Specifications .....	100-13

## DIVISION I

### TROUBLE DIAGNOSIS

#### 100-1 CAR ROUGHNESS AND VIBRATION

##### A. Possible Causes

To assist in the diagnosis and correction of some of the more stubborn cases of tire vibration and roughness conditions that may be encountered, the following information is offered:

**VIBRATION**, or a quivering motion condition, noticeable by feel through the steering column, steering wheel, floor pan, or by hood and fender shake, usually originates from the front wheels and

tires. Front end vibration, when caused by unbalanced front wheels, can be generally felt as steering wheel "nibble".

A vibration felt through the seats as a side-to-side disturbance can usually be attributed to the rear wheels and tires.

Both front and rear vibration can be noticed mainly at highway speeds, usually over 60 mph.

**ROUGHNESS**, noticeable primarily at speeds between 40 and 65 mph, can be felt (and occasionally heard), and is due to certain irregularities in the tire. Roughness usually sets up a "trembling" feel or a shuddering effect.

##### B. Road-Test With Owner

When a ride complaint is encountered, first check inflation pressures and perform tire inspection, including removal of any foreign material on tire tread or wheel large enough to upset balance.

Tire inflation pressure recommendations are very important at all times and particularly so on all ride complaints. Raising or lowering tire pressures to "improve" mileage or traction should not be attempted.

Next, road-test the car with the owner, if possible, and have the owner explain the specific ride disturbance.

After road-testing, raise car on hoist and proceed to isolate the offending tire/wheel assembly.

### C. Reproducing the Disturbance

In an attempt to reproduce the disturbance experienced in the ride, a wheel spinner can be used on the front wheels of the car.

The rear wheels may be spun by placing car in "Drive" with engine running. When spinning rear wheels, never exceed a speedometer speed of 35 mph with a standard rear axle assembly, or 70 mph on one with a positive traction rear axle. Excessive speeds may cause damage to the rear axle assembly.

*When spinning the rear wheels on a Buick equipped with a positive traction axle, jack up both rear wheels by placing the jack under the differential housing. Spin one wheel with opposite wheel removed. Use wheel nuts to hold the opposite brake drum to the axle shaft.*

Before removing the wheel, place a chalk mark on a stud and at a lug bolt hole so that the wheel will always be remounted in the same location.

When spinning rear wheels on a Buick equipped with a standard differential, jack up both rear wheels by placing the jack under the differential housing. Spin one wheel and tire with the opposite wheel held from rotating by holding the parking brake cable, as shown in Figure 100-1. Spin the other wheel using same procedure.

By spinning the wheels, the offending tire will cause vibration that may be felt by touching the bumper or fender. By the process of elimination, proceed on tires that cause vibration as follows:

### D. Unbalance

Check for tire/wheel unbalance - An unbalanced wheel assembly that is causing a vibration can, in most cases, be reduced to an acceptable level by static and dynamic wheel and hub balancing. Correct by re-balancing, Figure 100-2.

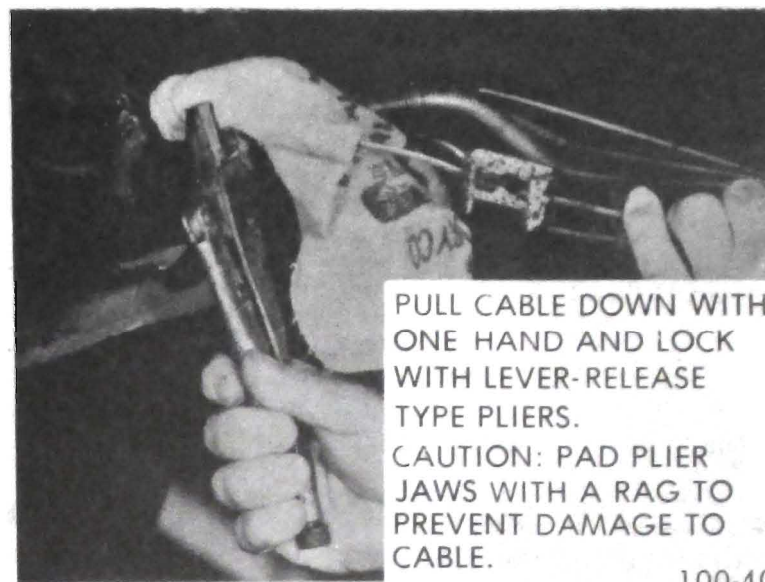

100-40

Figure 100-1 Using Parking Brake to Keep Rear Wheel From Rotating

It is recommended that an on-the-car balancer be used for balancing.

A tire/wheel assembly that is in balance may still be causing a vibration when the car is driven, but may not set up a vibration when the wheel is off the ground and submitted to the spinner test. In such cases, the next step is to check radial and lateral runout.

### E. Runout

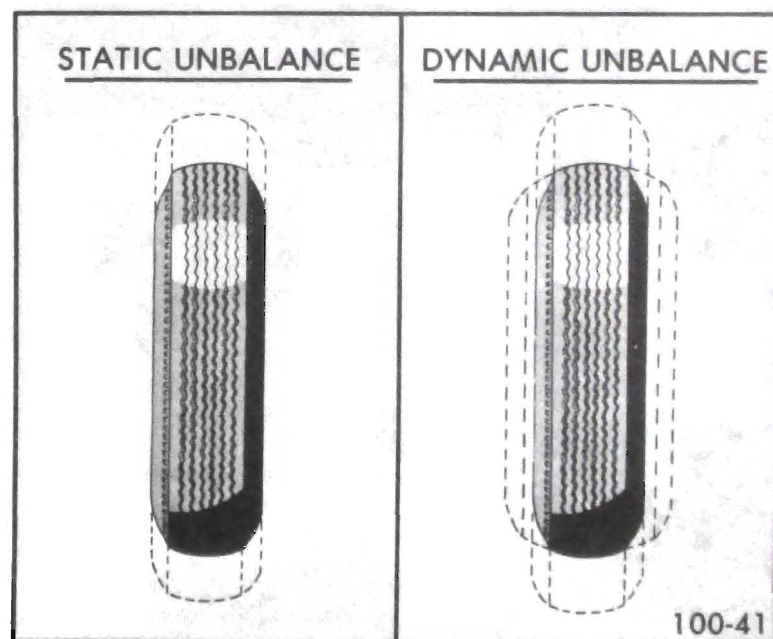

100-41

Figure 100-2 Static and Dynamic Unbalance

A runout gauge should be used to determine the amount of total radial and lateral runout at the tire that causes the vibration. See Figures 100-3 and 100-4.

A guide to runout maximum totals is as follows:

.035 inch radial - wheel

.050 inch radial - tire/wheel assembly

.045 inch lateral - wheel

.050 inch lateral - tire/wheel assembly

If the tire and wheel runouts are beyond any of the maximum totals above, the tire should be repositioned 180 degrees opposite its original location on the wheel. Refer to Figure 100-5. This will, in most cases, reduce the runout and vibration to a satisfactory level.

There is no more work involved in repositioning a tire on a wheel than there is in putting on a new tire, and repositioning has a better chance of correcting the difficulty.

It is important that only the tire/wheel assemblies that are causing the disturbances be repositioned. Since normally only one, and occasionally two, tire/wheel assemblies per vehicle could be causing the disturbing vibration, it is recommended that repositioning be performed only when required. Repositioning of non-disturbing assemblies could cause these assemblies to create vibration or roughness problems.

After repositioning, balancing the tire/wheel assembly is always necessary. It is very important that the tire/wheel assembly be balanced accurately.

At this point, the car should be road-tested again to assure that the disturbance has been corrected.

### F. Tire Grinding

Tire grinding is very effective in eliminating tire complaints due to excessive tire runout. Grinding can be accomplished on or off the car. Grinding is approved by Buick, if done as recommended by the equipment manufacturer.

### G. Tire Wear Irregularities

An additional cause of vibrations may sometimes be tire wear irregularities. These can also produce noise disturbances, and can be generally corrected by rotating the tires, Figure 100-6. Before proceeding further, locate and correct the cause of the irregular tire wear. See Figure 100-7.

Use the criss-cross method of rotation of tires only when all four tires are equally worn. In some instances, it may be necessary to put the truest running assemblies (those with the lowest tolerances) on the front of the car.

### H. Wheel Nut Torque and Tightening Sequence

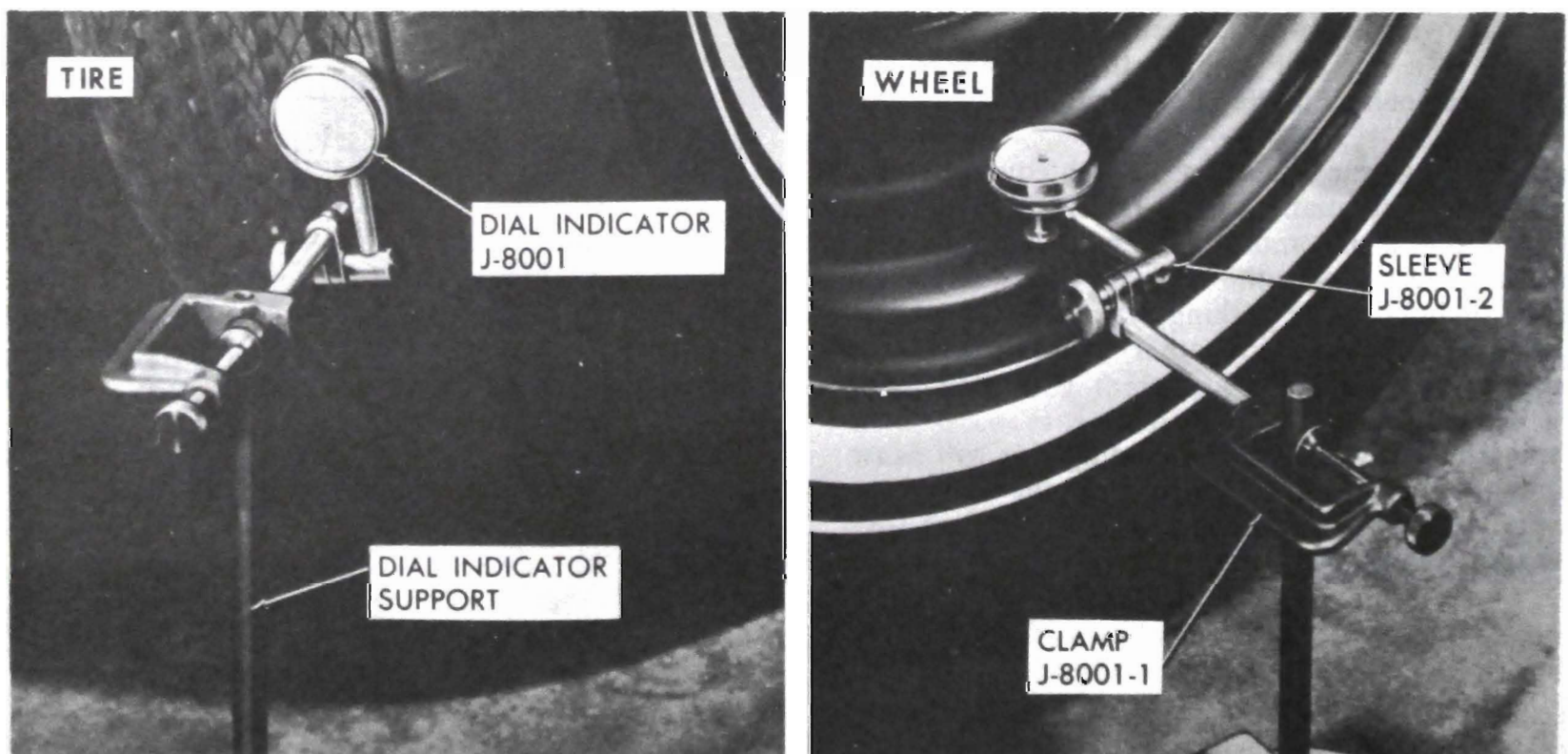

100-42

Figure 100-3 Checking Radial Runout



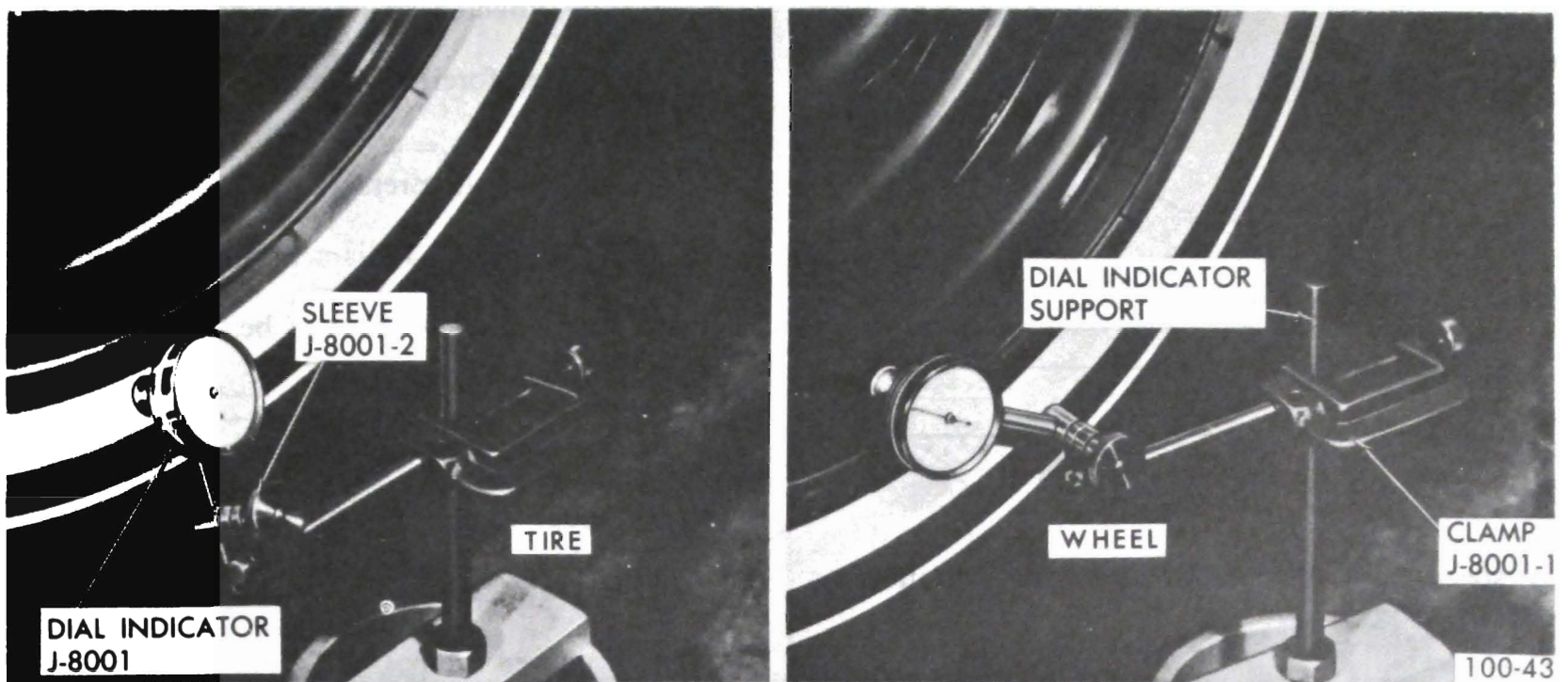
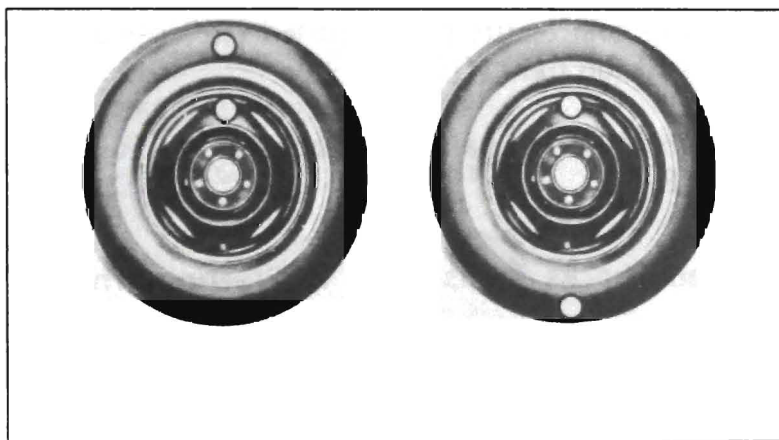

Figure 100-4 Checking Lateral Runout



100-44

Figure 100-5 Repositioning Tire on Wheel

During all wheel installations, it is important to use the correct procedure for installing wheel nuts and torquing them uniformly and in proper sequence. This is important in order to avoid possible distortion of the brake drum or disc, and to minimize damage to lug and nut threads and wheel stud holes.

To assure uniform tightening of wheel lug nuts, the following procedure is recommended:

1. Install wheel lug nuts in a criss-cross pattern and tighten just enough to seat wheel against hub. This assures proper piloting of the wheel on its hub.
2. Tighten lug nuts uniformly to proper torque of 70 ft. lbs., using criss-cross pattern. An impact wrench should not be used, as uniform torque control cannot be maintained. See Figure 100-8.

#### Summary of Diagnosis and Correction of Tire and Wheel Vibration

1. Inflate all tires to recommended pressure and road-test car with owner to define problem.
2. Spin front tire/wheel assemblies with wheel driving equipment. Rear wheels may be spun with tires off the ground and with one wheel held at a time. The offending tire may cause vibration that may be felt by touching the bumper or fender. By process of elimination, determine offending tire/wheel assembly.
3. Check for tire/wheel unbalance. Balance if necessary.
4. Check each tire/wheel assembly on the car for radial runout on the tire tread. Wheel and tire assemblies exceeding .050 inch may be considered as offending assemblies. Offending tire/wheel assembly should be deflated and the tire repositioned (indexed) 180 degrees from original location.
5. After repositioning, rebalance tire/wheel assembly (static and dynamic preferred).
6. Test drive and evaluate correction.

The following procedure should be used to determine cause of roughness or vibration with car in operation at various speeds:

1. Jack up all wheels having jack support rear end of car at center of rear axle housing.
2. With transmission in Drive run engine at various

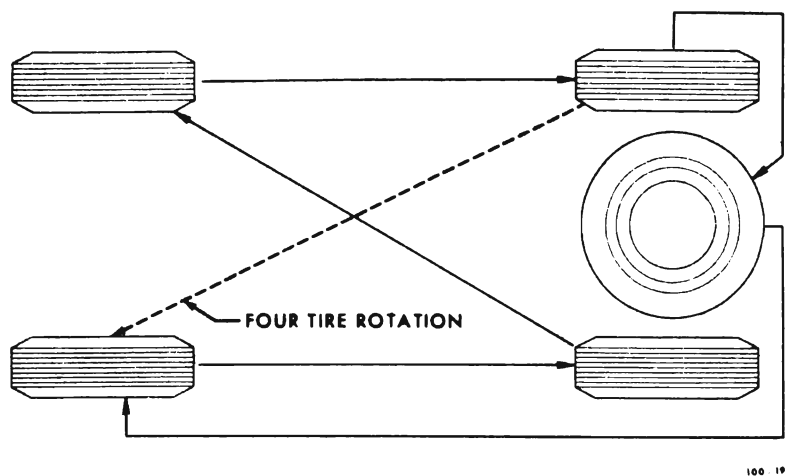

Figure 100-6 Tire Rotation

car speeds to note speeds at which vibration or roughness occurs.

3. Remove rear wheels and run engine again at the critical speeds noted in Step 2. If roughness is gone, the condition is caused by unbalanced wheel and tire assemblies.

4. If roughness still exists with rear wheels removed, remove rear brake drums and repeat the running test. Elimination of the roughness indicates out of balance brake drums.

5. If roughness still exists with brake drums removed, run engine with transmission in Neutral. Elimination of the roughness indicates that propeller shaft is out-of-balance. Continued roughness indicates an out-of-balance engine.

## 100-2 IMPROPER STEERING ACTION

Steering action is dependent upon the chassis suspension members as well as the steering gear assembly and tie rods. Improper steering actions which are most likely to be caused by chassis suspension are covered in this paragraph, while conditions most likely to be caused by the steering gear assembly or tie rods are covered in GROUP 90.

### A. Car Pulls or Leads to One Side

1. High crowned roads.
2. Low or uneven tire pressure (par. 100-4B).
3. Front tires of unequal diameter due to wear, make or size design.
4. Brakes dragging on one side (GROUP 50).
5. Incorrect caster, camber, or toe of front wheels (GROUP 30).
6. Frame bent or broken.

### B. Steering Affected by Application of Brakes

1. Oil or other foreign matter on brake lining (See GROUP 50).
2. Low or uneven tire pressure (par. 100-4B).
3. Front tires of unequal diameter due to wear.
4. Incorrect or uneven caster or bent steering knuckle (GROUP 30).

### C. Car Wander or Lack of Steering Stability

1. Heavy cross wind.
2. Type of road surface.
3. Low or uneven tire pressure (par. 100-4B).
4. Wheels toe out in straight ahead position (GROUP 30).
5. Incorrect or uneven caster or camber (GROUP 30).
6. Steering gear or tie rods adjusted too loose or worn, or adjusted too tight (GROUP 90).
7. No lubrication in ball joints or upper ball joint worn (GROUP 30).

### D. Road Shocks Transmitted to Steering Wheel

1. High or low tire pressure (par. 100-4).
2. Wrong type or size of tires used (par. 100-4).
3. Uneven tire wear (especially shoulder or corner wear).
4. Steering gear or tie rods loosely adjusted. Broken tie rod spring (GROUP 90).
5. Shock absorbers inoperative (GROUP 30).
6. Steering knuckle upper ball joint worn (GROUP 30).

### E. Front Wheel Shimmy (Low Speed)

Low speed shimmy is a rapid series of oscillations of the front wheel and tire assembly as the wheels attempt to point alternately to the right and left. This movement is often transmitted through the steering linkage to the steering gear. Low speed shimmy usually occurs below 30 mph.

1. Uneven or low tire pressure, or highly-worn tires (par. 100-4B).

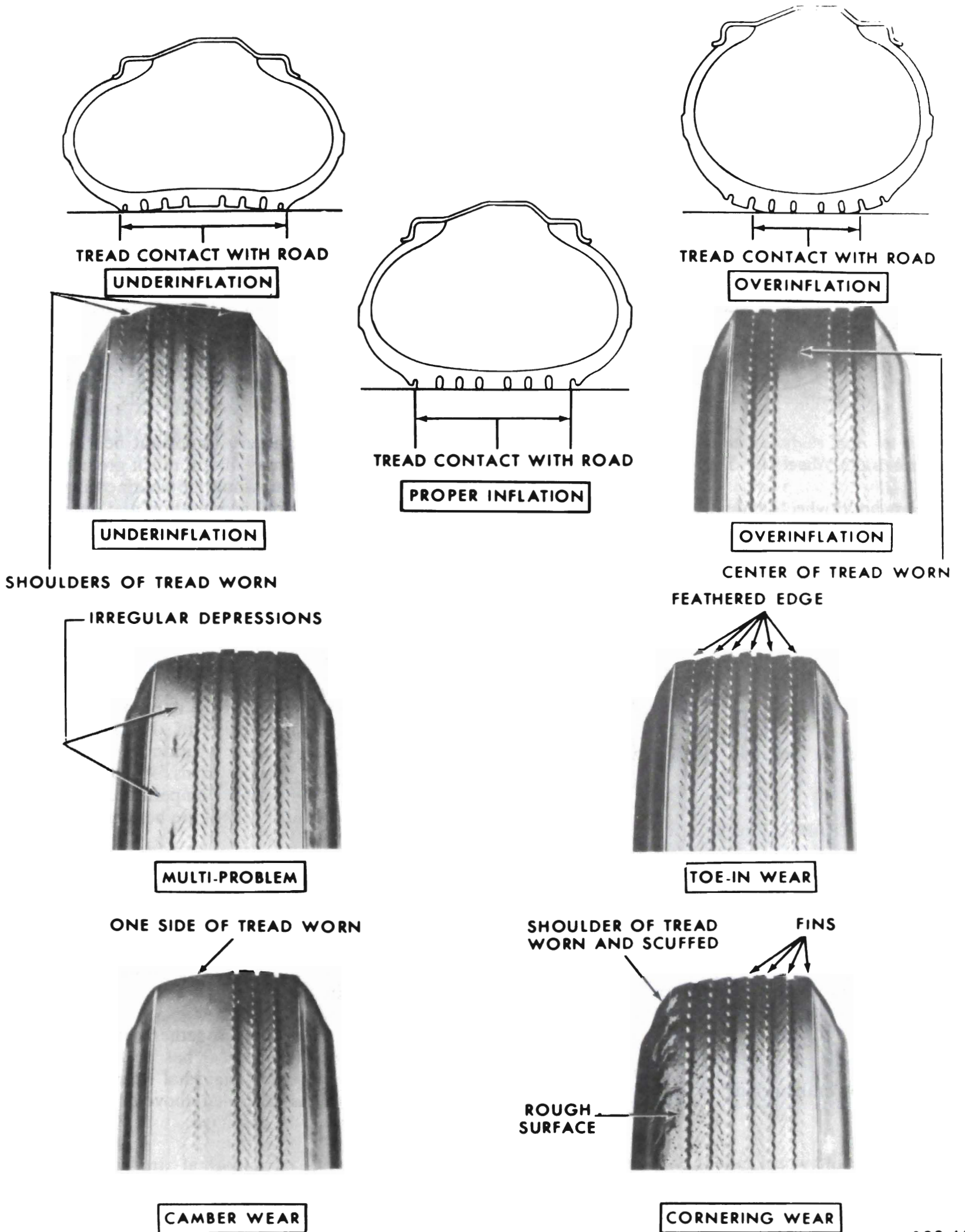
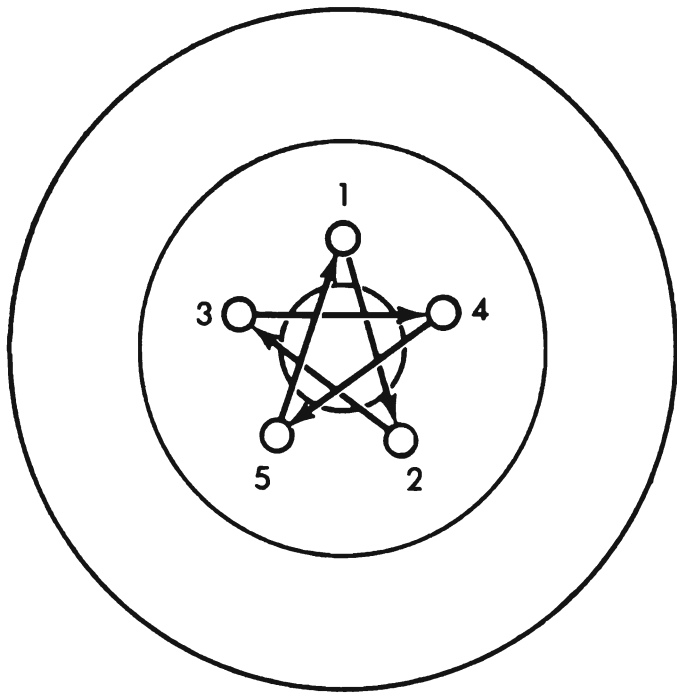

Figure 100-7 Uneven Tire Wear



100-47

Figure 100-8 Wheel Nut Tightening Sequence

2. One or both wheel and tire assemblies out of balance (GROUP 30).
3. Front wheel bearings loose or worn (GROUP 30).
4. Incorrect alignment of front wheels (GROUP 30).
5. Steering knuckle upper ball joint worn (GROUP 30).
6. Steering gear or tie rods incorrectly adjusted or worn (GROUP 90).

### 100-3 WHEEL TRAMP, FRONT OR REAR

Wheel tramp, sometimes called high speed shimmy, is a rapid up and down movement of a wheel and tire assembly, as though the tire was decidedly eccentric. In severe cases, the tire actually hops clear of the road surface. Wheel tramp may develop in either front or rear wheels and occurs at speeds above 35 MPH.

- a. Worn tires.
- b. Wheel, tire or brake drum out of balance (GROUP 30).
- c. Excessive tire and wheel runout.
- d. Shock absorber inoperative (GROUP 30).
- e. Items a,b, c, or d in combination with one or more items listed under Front Wheel Shimmy (sub-par. e).

## 100-4 ABNORMAL TIRE WEAR

### A. General Operating Conditions

Assuming that there is no misalignment condition to cause abnormal wear, the life of tires depends largely upon car operation conditions and driving habits.

Tires wear at a much faster rate in some localities than in others because of road and operating conditions. Some types of roads are much more abrasive than others. Tire wear is also dependent upon the number of hills and mountains which the car must go up and down, the severity of grades, the number of starts and stops, driving speeds, the amount of rain and snow, and prevailing temperatures. *Tire wear increases rapidly with speed, temperature, and load on tire.* Tires used at low speeds, in cool climates, or with light loads will have longer life than tires used for high speed driving in hot climates with heavy loads.

Driving habits have a very important bearing on tire life. A careful driver may obtain much greater mileage from a set of tires than would be obtained by a severe or careless driver. Rapid acceleration and deceleration, severe application of brakes, taking turns at excessive speed, high speed driving, and striking curbs or other obstructions which lead to misalignment are driving habits which will shorten the life of any tire.

Maintenance of proper inflation pressure and periodic interchanging of tires to equalize wear are within the control of the driver. Underinflation raises the internal temperature of a tire greatly due to the continual friction caused by the flexing of the side walls. Tire squealing on turns is an indication of underinflation or excessive speed on the turns. A combination of underinflation, high road temperatures, and high speed driving will quickly ruin the best tire made.

High speed on straight highways or expressways normally causes more rapid wear on the rear than on the front tires, although cupping of front tires can result if the tires are not periodically switched from wheel to wheel. Driving turns and curves at too high a rate of speed causes the front tires to wear much faster than the rear tires.

An inspection of the tires, together with information as to locality in which the car has been operated will usually indicate whether abnormal wear is due to the operating conditions described above or to mechanical faults which should be corrected.

The various types of abnormal tire wear and their causes are described in the following subparagraphs.

### B. Shoulder or Underinflation Tread Wear

When a tire is underinflated, the side walls and



shoulders of the tread carry the load while the center of tread folds in or compresses due to the low internal air pressure. This action causes the shoulders to take all of the driving and braking load, resulting in much faster wear of shoulders than of the center of tread. See Figure 100-9, Example A. For maximum results in handling, riding and tire life, tire inflation pressures should never be allowed to go below the specified minimum pressure.

Continuous high speed driving on curves, right and left, may produce tread wear very similar to underinflation wear and might very easily be mistaken for such. Side thrust when rounding turns causes wear on the sides of tire tread. In making a turn to the left, especially at high speeds, the outside shoulder of the right tire and the inside shoulder of the left tire take the side thrust and naturally receive the most wear. The only possible correction is to advise slower speeds on curves. Do not increase tire inflation pressures beyond specified limits as this will cause center or overinflation wear (subpar. c).

### C. Center or Overinflation Tread Wear

Excessive wheel camber, either positive or negative, causes the tire to run at such an angle to the road

surface that one side of the tread wears much more than the other. See Figure 100-9, Example D.

When tire inflation pressures are maintained within the specified limits, the tire will make a full contact across the entire width of tread, thereby distributing the wear evenly over the total surface of the tread area.

### D. Cross or Toe Tread Wear

When the front wheels have an excessive amount of either toe-in or toe-out, the tires are actually dragged sideways when they travel straight down the road and cross wear or scraping action takes place rapidly wearing away the tread of tires. This cross wear condition will usually produce a tapered or feathered edge on the ribs of the tire tread. See Figure 100-9, Example C. In most cases, this can be detected by rubbing the hand across the tire tread.

If the tapered or feathered edges are on the inner sides of the ribs on one or both sides, it indicates that one or both tires have excessive toe-in, while the same condition in the outer sides of ribs indicate excessive toe-out. *Usually, excessive toe-in causes excessive tire wear on the outer edge of the right front tire and toe-out*

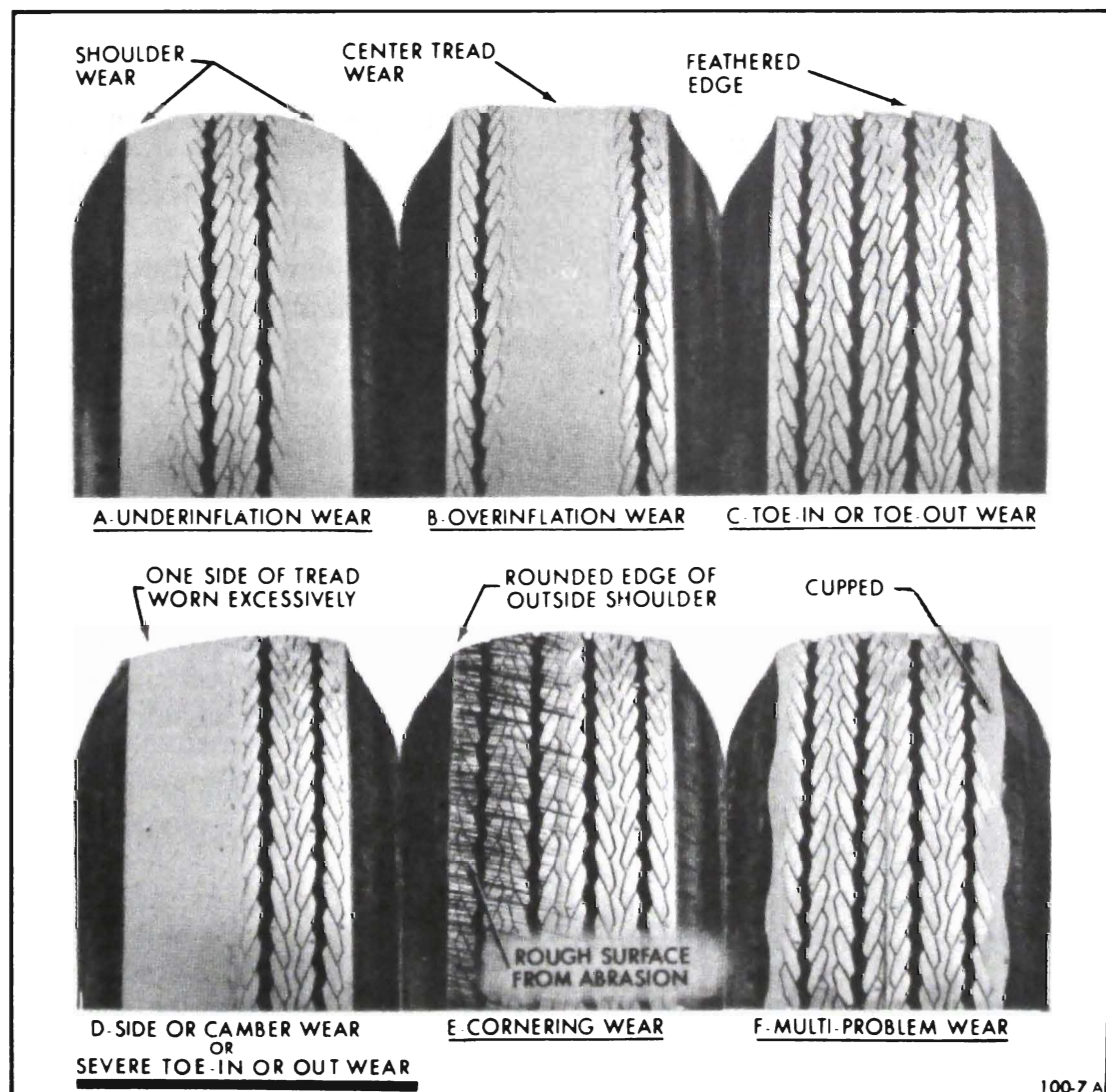

Figure 100-9 Abnormal Tire Wear Patterns



causes tire wear on the inner edge of the left front tire. See GROUP 30 for toe-in correction.

Cornering wear caused by high speed driving on curves (subpar. f. following) sometimes has the appearance of toe wear. Care must be used to distinguish between these two types of wear so that the proper corrective measures will be used.

#### E. Side or Camber Wear

Excessive wheel camber, either positive or negative, causes the tire to run at such an angle to the road surface that one side of the tread wears much more than the other. See Figure 100-9, Example D.

The amount or angle of the camber wear will be governed by the amount of positive or negative camber. Tire tread wear very similar in appearance to camber wear may be caused by driving on turns at excessive speeds. This "cornering" tread wear (subpar. f) cannot be corrected by change of camber angle.

Adjustments for specified camber are covered in GROUP 30.

#### F. Cornering Tread Wear

The modern independently sprung automobile allows the driver to negotiate turns at a high rate of speed with a greater feeling of safety. This fact is responsible for a comparatively new type of tread wear that can easily be mistaken for toe or camber wear.

When a car is making a turn, the tires are supposed to be rolling in a circle. When the turn is made at high speed, however, centrifugal force acting on the car causes the tires to be distorted sideways and to slip or skid on the road surface. This produces a diagonal cross type of wear, which in severe cases will result in a fin or sharp edge on each rib of the tire treads.

Cornering wear can be distinguished from toe or camber wear by the rounding of the outside shoulder of the tire and by the roughening of tread surface in this section denoting severe abrasion. See Figure 100-9.

No alignment or tire pressure change can be made that will relieve cornering wear. Only the driver can effect a cure and that is by slowing down on curves.

#### G. Heel and Toe Tread Wear

Heel and toe wear is a saw-tooth effect with one end of each tread block worn more than the other.

The end which wears is the one that first grips the road when the brakes are applied. High speed driving

and excessive use of the brakes will cause this type of irregular tire wear. This type of wear will occur on any type of block tread design. See Figure 100-9, Example F.

Heel and toe wear is not so prevalent on the rear tires because of the propelling action which creates a counteracting force which wears the opposite end of the tread block. These two stresses on the rear tires wear the tread blocks in opposite directions and result in more even wear while on the front tires, the braking stress is the only one which is effective. This may be counteracted by interchanging tires.

A small amount of irregular wear, slightly saw-toothed in appearance, at the outer segments of tires is a normal condition and is due to the difference in circumference between the center and the outer edges of the tire tread. This saw-toothed appearance, however, will be exaggerated by underinflation, improper toe-in, or both.

#### H. Cupped or Scalloped Type Tire Wear

Cupping or scalloping is associated with wear on a car driven mostly at highway speeds without recommended tire rotation. Factors which promote cupping include underinflation, incorrect toe-in setting or camber setting, and steady highway speeds on smooth, paved surfaces as opposed to gravel or rough asphalt.

The following recommendations suggest action that may be taken to help prevent cupping.

1. Rotate tires as recommended in Figure 100-10.
2. Frequently inspect front tires for irregular wear due to under-inflation, improper toe-in setting, or camber setting.

Regardless of the original cause of cupped tread wear on either front tire, no alignment or balance job, however perfect, can prevent future excessive wear of the spots. Once a front tire acquires flat or cupped spots, additional wear will continue at a rapid rate. At the time of correction, however, the cupped tire should be interchanged with a rear tire on which the tread runs true. The cupped tire will, to a certain degree, true itself on a rear wheel.

Although not normally the cause of cupping, the following factors can contribute to the problem.

Looseness of parts in the suspension system such as worn steering knuckle ball joints, loose wheel bearings, inoperative shock absorbers, and any excessive looseness throughout the steering system all tend to allow the front wheels to kick around, and if any of the wheel alignment factors are incorrect, irregular spotty tire tread wear of one type or another may result.

Wobble or runout of a tire, either front or rear, due to bent wheel or to tire being improperly mounted will cause uneven wear.

## DIVISION III

### ADJUSTMENTS AND MINOR SERVICE

#### 100-5 TIRE SERVICE AND INSPECTION

##### A. Tire Inflation and Inspection

Maintenance of correct inflation pressure in all tires is one of the most important elements of tire care. Correct tire pressure is also of great importance to ease of handling and riding comfort.

Overinflation is detrimental to tire life but not to the same degree as underinflation. Inflate all tires according to tire temperature as specified in paragraph 100-4B.

Driving without valve caps contributes to underinflated tires. The valve cap keeps dirt and water out of the valve core and seals the valve against leakage. Whenever tires are inflated, be sure to install valve caps and tighten firmly by hand. Make sure that rubber washer in cap is not damaged or missing.

If tires are checked at frequent intervals and adjusted to correct inflation pressure, it is often possible to detect punctures and make a correction before a tire goes flat, which may severely damage tire if car is in motion. Slight differences in pressure between tires will always be found, but a tire that is found to be 3 or more pounds below the lowest of its running mates can be suspected of having a leaking valve or a puncture.

All tires should be inspected regularly to avoid abnormal deterioration from preventable causes. If tires show abnormal or uneven wear, the cause should be determined and correction should be made.

See that no metal or other foreign material is imbedded in the tread. Any such material should be removed to prevent damage to tread and tire carcass. Cuts in a tire which are deep enough to expose the cords will allow dirt and moisture to work into the carcass and ruin the tire unless promptly repaired.

##### B. Tubeless Tire Repairs

A leak in a tubeless tire may be located by inflating the tire to recommended pressure (par. 100-4) and then submerging tire and wheel assembly in water, or by applying water to tire with a hose if wheel is mounted on car. Remove water from area where air bubbles show and mark the area with crayon. After removal of the puncturing object from tire, the puncture must be

sealed to prevent entrance of dirt and water which would cause damage to the tire carcass.

Tire repair kits are available through tire dealers. These materials should be used as directed in the instructions supplied with the kits. If a puncture is larger than 1/4" or there is other damage to the tire carcass, repairs should be made by authorized tire dealers in accordance with instructions of the tire manufacturer.

##### C. Wheel Leaks

Examine rim flanges for sharp dents. Any dent visible to the eye should be straightened, being careful not to make stress risers. The rim flanges should be thoroughly cleaned with No. 3 coarse steel wool thereby removing all oxidized rubber, soap solution, etc. If the flange is rusted, it can be cleaned with a wire brush.

In isolated cases loss of air may result from porous welds. Under no condition should porous welds be welded or peened.

##### D. Demounting and Mounting of Tubeless Tire

When demounting a tubeless tire use care to avoid damaging the rim-seal ridges on tire beads. *DO NOT USE TIRE IRONS TO FORCE BEADS AWAY FROM WHEEL RIM FLANGES.* When tire is removed, inspect it carefully to determine whether loss of air was caused by puncture or by improper fit of beads against rim flanges. If improper fit is indicated, check wheel as follows:

1. Straighten wheel rim flanges if bent or dented, being careful not to make stress risers.
2. Clean rims thoroughly, using No. 3 coarse steel wool or wire brush to remove all oxidized rubber, soap solution, etc. Remove rust with wire brush.
3. Inspect butt weld and other areas of rim contacted by tire beads to make certain there is no groove or high spot. Remove any groove or high spot by filing smooth, being careful not to leave any notches.
4. Inspect valve stem and replace it if damaged. Make certain that valve stem is properly installed to provide an air tight joint.

Before mounting a tubeless tire on a wheel, moisten a cloth with mounting compound or soap solution and wipe rim-seal ridges of both beads to remove all foreign substances.

Moisten base of both beads with mounting compound or soap solution to help beads snap into place when tire is inflated. Start tire over rim flange at point opposite valve stem. Align balance mark on tire with valve stem.

Inflate tire until both beads are firmly seated against rim flanges and temporarily inflate to 50 pounds pressure. Leak test wheel and tire assembly and, if satisfactory, reduce to recommended pressure.

### E. Interchanging Tires

Tires tend to wear unevenly and become unbalanced as mileage accumulates. Uneven tire wear is frequently the cause of tire noises which are attributed to rear axle gears, bearings, etc., and work is sometimes needlessly done on rear axles in an effort to correct the noise.

Tire life will be increased and uneven wear and noise will be less likely to occur if the tires, including the spare, are balanced and interchanged at regular intervals of approximately 6000 miles. The recommended method of interchanging tires is shown in Figure 100- 10.

### F. Use of Tire Chains

Do not use tire chains on the front wheels under any circumstances because they will interfere with the steering mechanism. Any of the conventional full-type non-skid tire chains can be used on the rear wheels.

Tire chains should be loose enough to "creep" but tight enough to avoid striking fenders or other parts. If chains remain in one position, the tire side wall will be damaged. Tension springs (either metal coil springs or the rubber band type) must also be used in order to prevent chains contacting frame, etc. The use of tension springs will also reduce ordinary chain noise caused by loose cross links contacting pavement. On all models equipped with rear fender skirts, the skirts should be left OFF when tire chains are used.

### G. Wheel and Tire Balance

Wheel and tire balance is the equal distribution of the weight of the wheel and tire assembly around the axis of rotation. Wheel unbalance is the principal cause of

tramp and general car shake and roughness and contributes somewhat to steering troubles.

The original balance of the tire and wheel assembly may change as the tire wears. Severe acceleration, severe brake applications, fast cornering and side slip wear the tires out in spots and often upset the original balance condition and make it desirable to rebalance the tire and wheel as an assembly. Tire and wheel assemblies should be rebalanced after punctures are repaired.

Because of the speed at which cars are driven, it is occasionally necessary in a severe case to test the wheel and tire assembly for dynamic balance. Dynamic balancing of a wheel and tire assembly must be done on a machine designed to indicate out-of-balance conditions while the wheel is rotating.

**WARNING:** When balancing tires on the car, follow the equipment manufacturer's instructions carefully on cars which "do not" have positive traction. Drive wheel spin should be limited to 35 mph as indicated on the speedometer. This limit is necessary because the speedometer only indicates one-half of the actual wheel speed when one drive wheel is spinning and the other drive wheel is stopped. Unless care is taken in limiting drive wheel spin, the spinning wheel can reach excessive speeds, resulting in possible tire disintegration or differential failure which could cause personal injury or extensive vehicle damage.

**WARNING:** On cars which "do" have positive traction, drive wheel spin should be limited to 70 mph. On such cars, do not attempt to balance a tire on a drive wheel with the other drive wheel on the ground, since the car may drive through this wheel.

1. Jack up both rear wheels by placing the jack under the differential housing.

2. Balance one wheel, leaving the opposite wheel attached to the axle. With positive traction, remove one (1) wheel and brake drum. Place block under brake pedal. Balance the remaining wheel. Use engine to drive rear wheels for balancing and never exceed a speedometer speed of 35 M.P.H. on a Buick with a standard rear axle assembly or 70 M.P.H. on one with a Positive Traction rear axle. Excessive speeds do not improve the balancing operation and may cause damage to the rear axle assembly.

3. Balance the other wheel, observing the speed precautions as noted above. Do not remove the previously-balanced wheel as it is now in balance and will not affect the balancing operation.

In some cases, off-the-car wheel and tire balance does not overcome wheel balance complaints because the

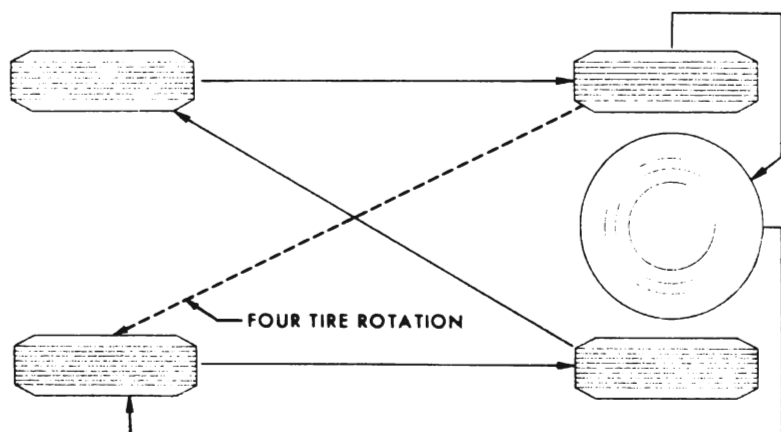

Figure 100-10 Tire Rotation Method



brake drums themselves are out-of-balance. In this case, either balance the tire and wheel with an on-the-car spin balance or correct the brake drum balance as described in GROUP 50.

## DIVISION VI SPECIFICATIONS

### 100-6 BOLT TORQUE SPECIFICATIONS

Use a reliable torque wrench when tightening the parts listed below. This will prevent strain or distortion of the parts or damage to the threads. The specifications given are for clean and lubricated threads only. Dry or dirty threads produce increased friction and prevent accurate measurement of tightness. It is important that these specifications be strictly observed. Overtightening may damage threads and prevent the attainment of the proper torque.

Wheel Attaching Nuts	Torque Lb.Ft.
V.I.N. Code 4D-4H-4G-4F	
Front .....	70
Rear .....	70
Front (Chrome) .....	70
Rear (Chrome) .....	70
V.I.N. Code 4L-4N-4R-4P-4U-4V-4Y	
Front .....	75
Rear .....	75
Front (Chrome) .....	75
Rear (Chrome) .....	75

### 100-7 WHEEL AND TIRE SPECIFICATIONS

#### A. Wheel Usage Chart

V.I.N. Code	4D-4H-4F	4G	4L-4N-4R-4P-4U- 4V-4Y Series
Standard Size	14 x 6JJ	14 x 6JJ	15 x 6JJ
Optional Size	N/A*	15 x 7JJ	N/A*
Rim Type .....	Drop Center	Drop Center	Drop Center
No. of Attaching Studs	5	5	5
Stud Circle Diameter	4.750"	4.750"	5.0"
Stud Size	7/16-20	7/16-20	1/2-20
*Not Available			

#### B. Tire Size Chart

V.I. N. Code	Standard Tire	Optional Tire
		Oversize or Wide Oval
4D-4H	G78-14	H78-14
4F	H78-14	N/A*
4G	G78-14	G70-14 - G60-15 - H78-14
4L-4N-4P	H78-15	J78-15
4R	L78-15	N/A*
4U-4V	J78-15	N/A*
4Y	H78-15	N/A*
4Y-G.S.	H78-15	H70-15

\*Not Available

## Recommended Tire Inflation Pressures

V.I.N. Code	Tire Load Rating	Std. Inflation For All Loads Including Full Rated Loads	Optl. Inflation Recommended For Reduced Loads
4D-4H	B	1-6 Passengers + 200 Lbs Luggage (1100 Lbs Load) Front 26 psi      Rear 28 psi	1-5 Passengers (750 Lbs Max) Front 24 psi      Rear 24 psi
4G	B	1-6 Passengers + 200 Lbs Luggage (1100 Lbs Load) Front 28 psi      Rear 28 psi	1-5 Passengers (750 Lbs Max) Front 26 psi      Rear 26 psi
4F	B	1-6 Passengers + 300 Lbs Luggage (1200 Lbs Load) Front 26 psi      Rear 32 psi	1-5 Passengers (750 Lbs Max) Front 24 psi      Rear 28 psi
4L-4N-4P-4U-4V	B	1-6 Passengers + 200 Lbs Luggage (1100 Lbs Load) Front 26 psi      Rear 30 psi	1-5 Passengers (750 Lbs Max) Front 26 psi      Rear 30 psi
4R	B	1-6 Passengers + 300 Lbs Luggage or 8 Passengers (1200 Lbs Load) Front 22 psi      Rear 32 psi	1-5 Passengers (750 Lbs Max) Front 22 psi      Rear 28 psi
4Y	B	1-6 Passengers + 200 Lbs Luggage (1100 Lbs Load) Front 24 psi      Rear 28 psi	1-5 Passengers (750 Lbs Max) Front 24 psi      Rear 24 psi

**NOTE:**

1. Tire inflation pressures may increase as much as 6 pounds per square inch (psi) when hot.
2. For continuous high-speed operation (over 70 mph), increase tire inflation pressures 4 pounds per square inch over the recommended pressures up to a maximum of 32 pounds per square inch cool for 4 ply rating tires, or 40 pounds per square inch cool for 8 ply rating tires. Sustained speeds above 70 mph are not recommended when the 4 pounds per square inch adjustment would require pressures greater than the maximums stated above.

**(Alternate for Station Wagons)**

For continuous high-speed operation (over 70 mph), increase tire inflation pressures 4 pounds per square inch over the recommended pressures up to a maximum of 32 pounds per square inch cool for 4 ply rating tires, or 40 pounds per square inch cool for 8 ply rating tires. On station wagons, when the 4 psi pressure adjustment for sustained high speed with maximum vehicle load would require inflation pressures above the maximum allowable, speed must be limited to 70 mph.

3. Cool tire inflation pressure: After vehicle has been inoperative for 3 hours or more, or driven less than one mile. Hot tire inflation pressure: After vehicle has been driven ten miles or more at 60-70 mph.
4. Station wagon loads should be distributed as far forward as possible.
5. Vehicles with luggage racks do not have a vehicle load limit greater than specified.
6. When towing trailers, the allowable passenger and cargo load must be reduced by an amount equal to the trailer tongue load on the trailer hitch.



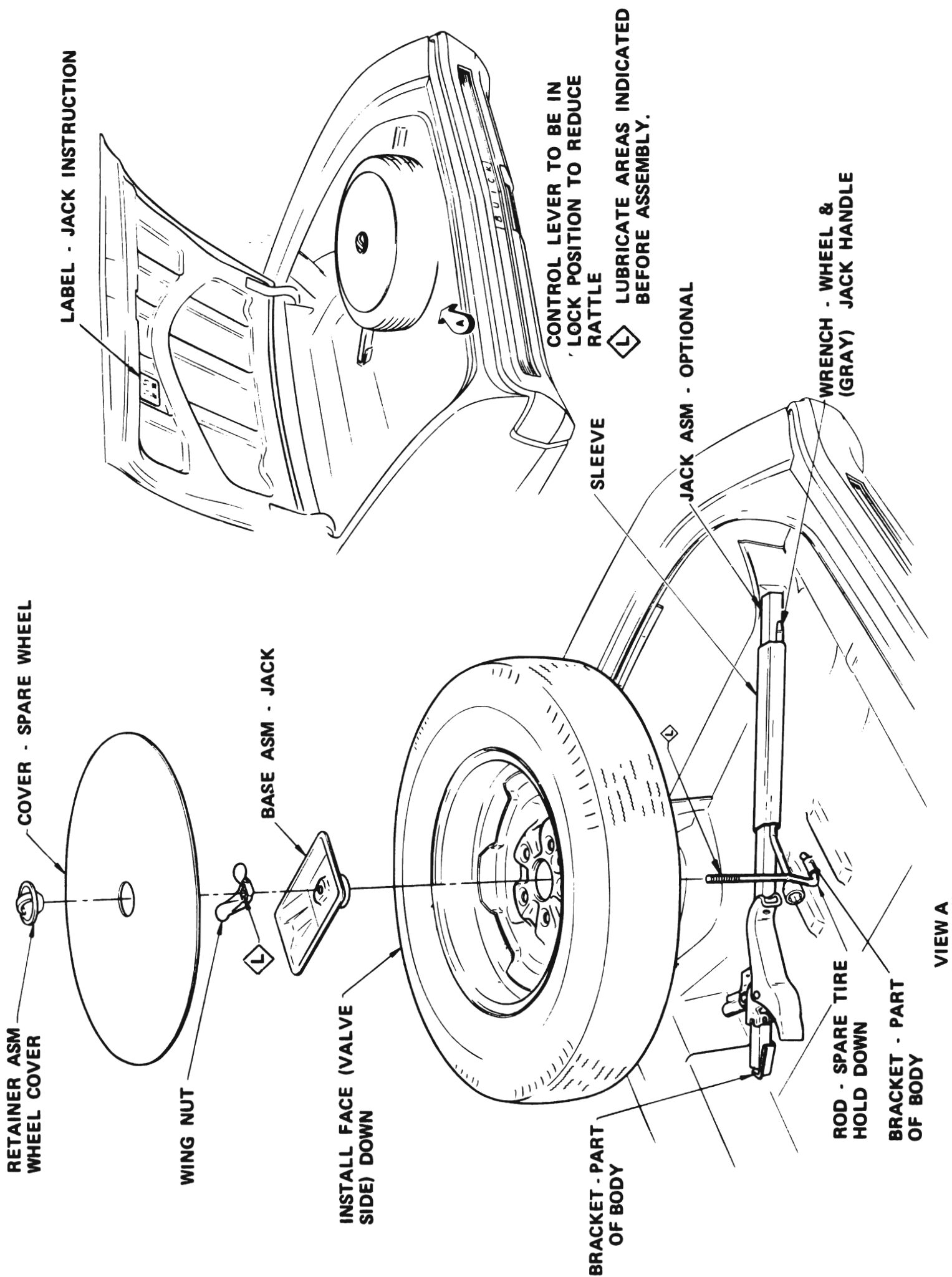
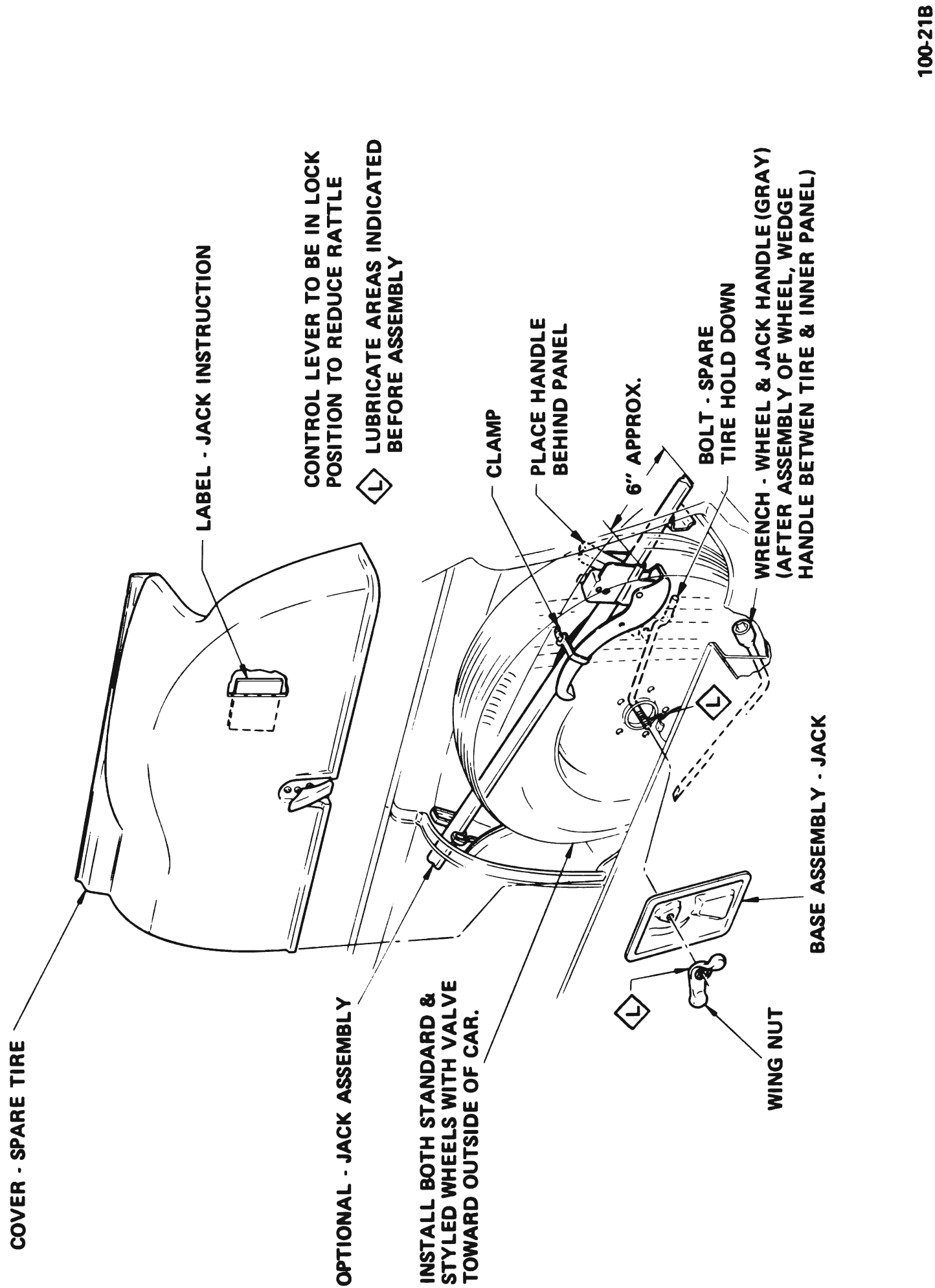

Figure 100-11 Spare Tire and Jack Installation - 4D-4G-4H Series



100-21B

Figure 100-12 Spare Tire and Jack Installation - Sportwagon

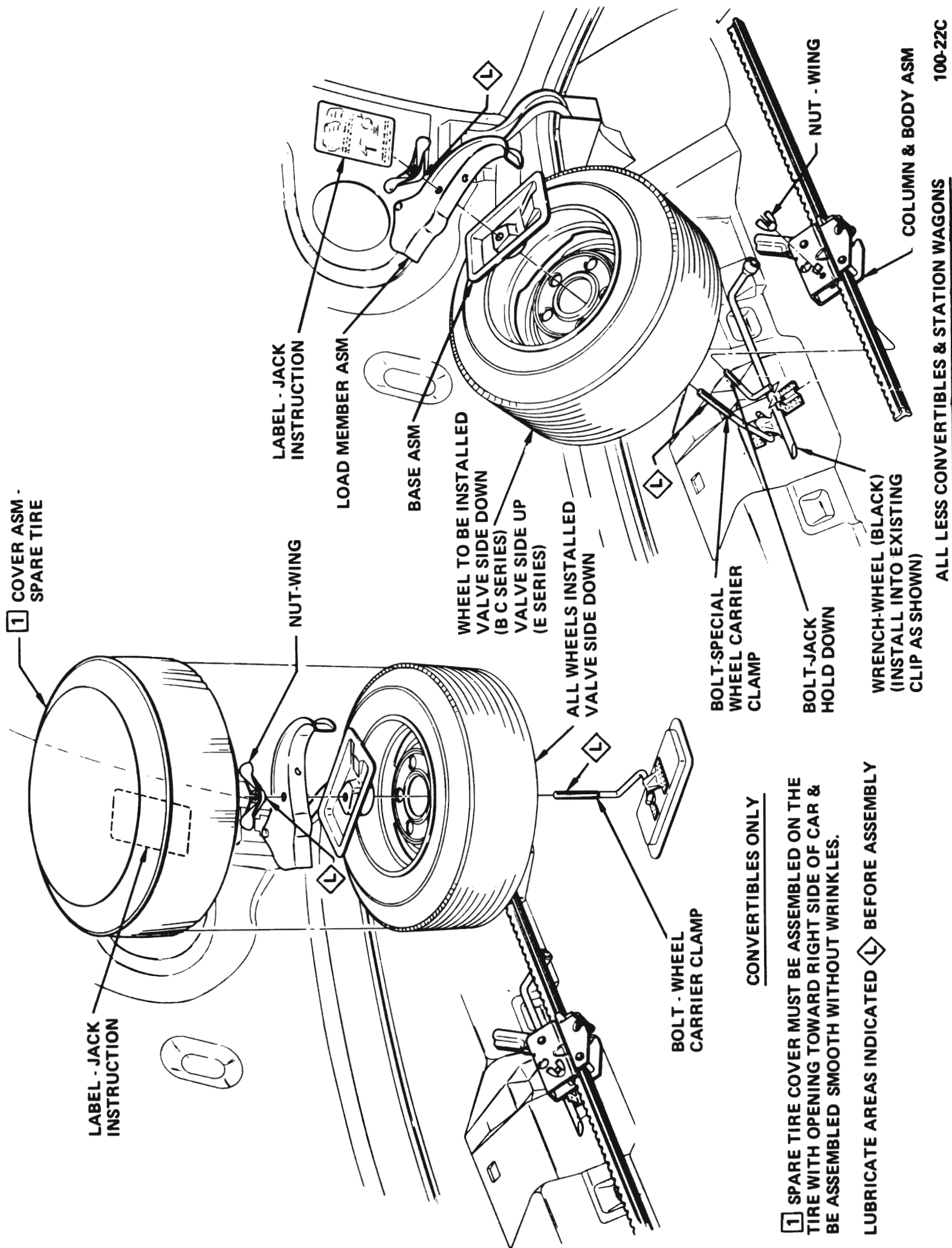
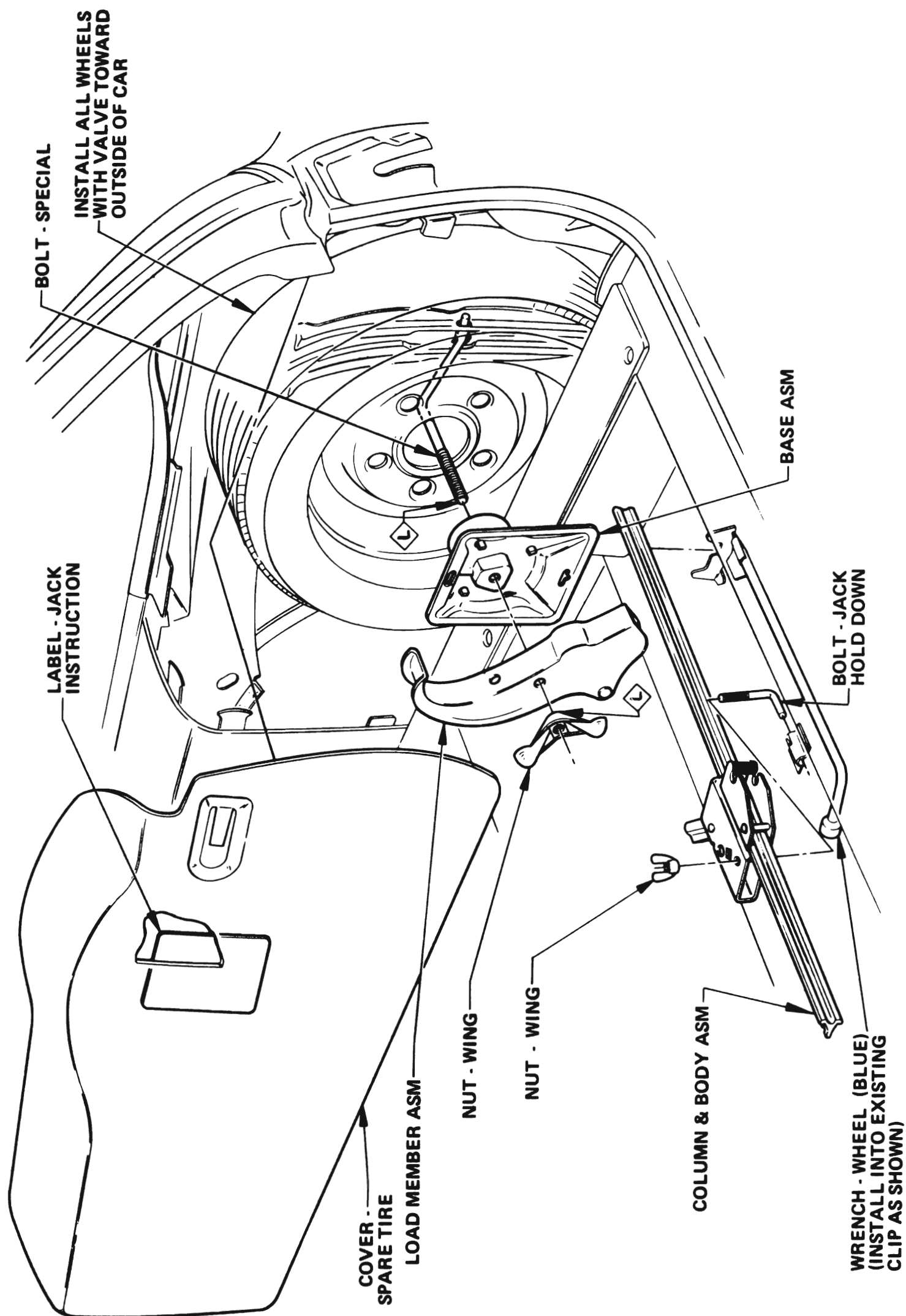

Figure 100-13 Spare Tire and Jack Installations - 4L-4N-4R-4P-4U-4V-4Y Series





LUBRICATE AREAS INDICATED **L** BEFORE ASSEMBLY

Figure 100-14 Spare Tire and Jack Installation - Estate Wagon