

# SECTION B

## POWER STEERING GEAR and PUMP ALL SERIES

### CONTENTS

Division	Subject	Paragraph
I	<b>TROUBLE DIAGNOSIS:</b> Trouble Diagnosis . . . . .	90-7
II	<b>DESCRIPTION AND OPERATION:</b> Description of Power Steering Gear . . . . . Description and Operation of Power Steering Oil Pump and Hoses . . . . . Operation of Power Steering Gear . . . . .	90-8 90-9 90-10
III	<b>ADJUSTMENTS AND MINOR SERVICE:</b> Adjustments of Power Steering Gear . . . . . Removal and Installation of Pitman Shaft Seals, Gear In Car . . . . .	90-11 90-12
IV	<b>REMOVAL AND INSTALLATION:</b> Removal and Installation of Power Steering Gear Assembly . . . . . Removal and Installation of Power Steering Oil Pump Removal and Installation of Oil Pump Shaft Seal With Pump Assembled . . . . .	90-13 90-14 90-15
V	<b>OVERHAUL AND MAJOR SERVICE:</b> Disassembly, Inspection and Reassembly of Adjuster Plug Assembly and Rotary Valve Assembly . . . . . Disassembly, Inspection and Reassembly of Pitman Shaft Assembly . . . . . Disassembly, Inspection and Reassembly of Rack- Piston Nut and Worn Assembly . . . . . Disassembly, Inspection and Reassembly of Oil Pump . . . . .	90-16 90-17 90-18 90-19
VI	<b>SPECIFICATIONS:</b> Power Steering Gear and Pump Specifications . . . . .	90-20

# DIVISION I

## TROUBLE DIAGNOSIS

### 90-7 TROUBLE DIAGNOSIS

**NOTE:** This paragraph covers only those causes of trouble which may be due to the hydraulic power mechanism. Causes which are due to the steering linkage and front suspension are the same as described for standard steering gear.

COMPLAINT AND CAUSE	CORRECTION
<p><b>a. HARD STEERING WHILE DRIVING</b></p> <ol style="list-style-type: none"> <li>1. Lower coupling flange rubbing against adjuster plug.</li> <li>2. Steering adjustment tight.</li> <li>3. Insufficient pressure build-up in gear power cylinder due to leak or faulty valve.</li> <li>4. Incorrect installation or operation of the gear check valve poppet.</li> </ol>	<ol style="list-style-type: none"> <li>1. Loosen pinch bolt and assemble properly. There should be 1/16" clearance between plug and flange.</li> <li>2. Check adjustment by disconnecting pitman arm from gear. (Par. 90-11)</li> <li>3. Replace defective parts.</li> <li>4. Check operation of valve, paragraph 90-18, subparagraph c, Step 6. (See Figure 90-23)</li> </ol>
<p><b>b. POOR RETURN OF STEERING GEAR TO CENTER</b></p> <ol style="list-style-type: none"> <li>1. Lower coupling flange rubbing against adjuster plug.</li> <li>2. Tighten pitman sector to rack-piston nut adjustment.</li> <li>3. Rack-piston nut to worm preload too tight.</li> <li>4. Thrust bearing adjustment incorrect.</li> <li>5. Sticky valve spool.</li> <li>6. Steering column misalignment</li> </ol>	<ol style="list-style-type: none"> <li>1. Loosen pinch bolt and assemble properly.</li> <li>2. Adjust in car to specification. Par. 90-11</li> <li>3. Remove gear and replace balls as required.</li> <li>4. Adjust to specification.</li> <li>5. Remove and clean valve. Replace rotary valve assembly if necessary.</li> <li>6. Realign</li> </ol>
<p><b>c. PUMP INOPERATIVE OR POOR OR NO ASSIST</b></p> <p><b>NOTE:</b> Refer to subparagraph i, Step 4, to determine if pump is at fault.</p> <ol style="list-style-type: none"> <li>1. Loose drive belt.</li> <li>2. Low oil level.</li> <li>3. Air in the oil.</li> <li>4. Defective hoses.</li> <li>5. Flow control valve stuck open.</li> <li>6. Loose screw in end of flow control valve.</li> <li>7. Pressure plate not flat against ring.</li> <li>8. Extreme wear of pump ring.</li> <li>9. Scored pressure plate, thrust and/or rotor.</li> <li>10. Vanes not installed properly.</li> <li>11. Vanes sticking in rotor slots.</li> <li>12. Faulty flow control valve assembly.</li> <li>13. "O" ring improperly installed on pressure union.</li> <li>14. End plate improperly installed or seal damaged.</li> </ol>	<ol style="list-style-type: none"> <li>1. Tighten belt.</li> <li>2. Fill reservoir.</li> <li>3. Locate source of air leak and correct.</li> <li>4. Replace hose.</li> <li>5. Remove burrs or dirt.</li> <li>6. Tighten.</li> <li>7. Properly seat pressure plate against ring.</li> <li>8. Replace part.</li> <li>9. Lap off light scoring. Replace heavily scored parts.</li> <li>10. Install properly.</li> <li>11. Free up by removing burrs or dirt.</li> <li>12. Replace assembly.</li> <li>13. "O" ring must be in groove nearest outlet of union.</li> <li>14. Install properly. Replace seal.</li> </ol>

## TROUBLE DIAGNOSIS—POWER STEERING GEAR AND PUMP (Cont'd)

COMPLAINT AND CAUSE	CORRECTION
<p>d. MOMENTARY INCREASE IN EFFORT WHEN TURNING WHEEL FAST TO THE RIGHT OR TO THE LEFT.</p>	
<p>1. Air in system. 2. Low oil level in pump. 3. High internal leakage.</p>	<p>1. Bleed gear. 2. Check oil level in pump reservoir. 3. Replace rack-piston ring and back-up "O" ring, rack-piston nut end plug seal, and/or replace valve.</p>
<p><b>NOTE:</b> With engine idling, very fast movements of steering wheel may give higher effort or feel. This is a normal result and will last momentarily until the system "catches up" with the position of the valve.</p>	
<p>e. EXTERNAL OIL LEAKS</p>	
<p><b>NOTE:</b> Wipe gear and pump thoroughly and make sure source of leakage is determined.</p>	
<p>1. Gear leaks.</p>	
<p>(a) Loose hose connections. (b) Damaged hose. (c) Side cover "O" ring seal. (d) Pitman shaft seal. (e) Housing end plug "O" ring seal. (f) Adjuster plug "O" ring seal. (g) Torsion bar "O" ring seal (See Figure 90-17). (h) Pitman shaft lash adjuster nut. (i) Stub shaft seal.</p>	<p>(a) Tighten. (b) Replace. (c) Replace seal. (d) Replace seals. (e) Replace seal. (f) Replace seal. (g) Replace valve. (h) Replace nut. (i) Replace seal.</p>
<p>2. Pump leaks.</p>	
<p>(a) Oil leaking at top of reservoir as it is too full. (b) Oil leaking at top of reservoir caused by air bubbles in oil. (c) Reservoir "O" ring seal damaged or improperly installed. (d) Pressure union or reservoir to housing bolt and stud not tightened sufficiently. (e) Pressure union or reservoir to housing bolt and stud cross threaded or damaged. (f) Defective pressure fitting seat on hose end. (g) Damaged reservoir to housing or pressure union "O" ring seals. (h) Defective shaft seal. (i) Damaged shaft at seal area. (j) Leaks in metal parts. (Example: Drawing crack in reservoir.)</p>	<p>(a) Remove oil to proper level. (b) Locate source of air leak and correct. (c) Replace "O" ring. (d) Torque union and stud and bolt to 35 lb. ft. (e) Replace damaged parts. (f) Replace hose. (g) Replace seals. (h) Replace seal. (i) Replace shaft. (j) Replace defective part.</p>

## TROUBLE DIAGNOSIS—POWER STEERING GEAR AND PUMP (Cont'd)

COMPLAINT AND CAUSE	CORRECTION
<b>f. NOISE</b>	
1. Gear Noise (rattle or chuck).	
(a) Loose "overcenter" adjustment.	(a) Adjust to specification.
<b>NOTE:</b> A slight rattle may occur on turns because of the increased lash when off the "high point". This is normal and the lash must not be reduced below the specified limits to eliminate this slight rattle.	
(b) Gear loose on frame.	(b) Tighten mounting bolts to 70 lb. ft.
2. Gear Noise ("hissing" sound).	
(a) A hissing noise is natural when steering wheel is at end of travel or when slowly turning at stand still.	(a) Do not replace valve unless "hiss" is extremely objectionable. Investigate clearance around safety drive rivet pins. Be sure there is no metal-to-metal contact around flexible coupling as this will transmit valve hiss to car. Normally this shows up as an intermittent hiss. Realign steering column if necessary.
3. Gear Noise (squawk when turning or when recovering from a turn).	
(a) Cut or worn dampener "O" ring on valve spool.	(a) Replace dampener "O" ring.
4. Pump noise.	
(a) Loose belt.	(a) Tighten belt.
(b) Hoses touching other parts of car.	(b) Adjust hose positions.
(c) Low oil level.	(c) Fill reservoir.
(d) Air in the oil.	(d) Locate source of air leak and correct.
(e) Excessive back pressure caused by hoses or steering gear.	(e) Locate restriction and correct. With pressure gauge installed in pressure hose between pump and gear and engine running at 1500 RPM, oil warm, and no effort on the steering wheel. Pressure should not exceed specification. Check operation of check valve poppet, paragraph 90-18, subparagraph c, Step 6.
(f) Scored pressure plate.	(f) Lap out light scoring. Replace heavily scored part.
(g) Vanes not installed properly.	(g) Install properly.
(h) Vanes sticking in rotor slots.	(h) Free up by removing burrs and dirt.
(i) Extreme wear of pump ring.	(i) Replace part.
(j) Face of thrust plate scored.	(j) Lap out light scoring. Replace heavily scored part.
(k) Scored rotor.	(k) Lap out light scoring. Replace heavily scored part.
(l) Defective flow control valve.	(l) Replace.

## TROUBLE DIAGNOSIS—POWER STEERING GEAR AND PUMP (Cont'd)

COMPLAINT AND CAUSE	CORRECTION
<p><b>g. EXCESSIVE WHEEL KICKBACK OR LOOSE STEERING</b></p> <ol style="list-style-type: none"> <li>1. Air in system.</li> <li>2. Excessive lash between pitman shaft sector and rack-piston.</li> <li>3. Loose thrust bearing adjustment.</li> <li>4. Rack-piston nut to worm preload to low.</li> <li>5. Incorrect installation or operation of the gear check valve poppet.</li> </ol>	<ol style="list-style-type: none"> <li>1. Add oil to pump reservoir and bleed.</li> <li>2. Adjust to specification.</li> <li>3. Remove gear and adjust to specification.</li> <li>4. Remove rack-piston nut and worm, and change balls to obtain specified preload.</li> <li>5. Check operation of valve, paragraph 90-18, subparagraph c, Step 6.</li> </ol>
<p><b>h. STEERING WHEEL SURGES OR JERKS WHEN TURNING WITH ENGINE RUNNING</b> Loose pump belt.</p>	<p>Adjust to specification.</p>
<p><b>i. HARD STEERING WHEN PARKING</b></p> <ol style="list-style-type: none"> <li>1. Loose pump belt.</li> <li>2. Low oil level in reservoir.</li> <li>3. Steering gear adjustments tight.</li> <li>4. Insufficient oil pressure.</li> </ol>	<ol style="list-style-type: none"> <li>1. Adjust to specification.</li> <li>2. Fill to proper level. If excessively low, check all lines and joints for evidence of external leakage.</li> <li>3. Adjust to specification.</li> <li>4. If all of the above checks do not reveal the cause of hard steering, make the following tests of oil pressure:             <ol style="list-style-type: none"> <li>(a) Disconnect the pressure line at oil pump. Attach pressure gage to pump. Connect the hose to end of gage where the valve is located.</li> <li>(b) With engine at hot idle and gage valve open, note the oil pressure on the gage while turning steering wheel from one extreme position to the other. Especially note the maximum pressure which can be built up with the wheel held in either right or left extreme position. <b>CAUTION:</b> Do not hold wheel in extreme position for an extended period of time because it will drastically increase the oil temperature and will cause undue wear on the oil pump.</li> <li>(c) With oil temperature between 150°F and 170°F, as measured with a thermometer in the reservoir, the maximum oil pressure should not be less than 1000 psi for satisfactory power steering operation.</li> </ol> </li> </ol>

## TROUBLE DIAGNOSIS—POWER STEERING GEAR AND PUMP (Cont'd)

COMPLAINT AND CAUSE	CORRECTION
i. <b>HARD STEERING WHEN PARKING</b> (Cont'd)	<p>(d) If the maximum oil pressure is less than 1000 psi, it indicates trouble in the pump, oil hoses, steering gear, or a combination of these parts. To eliminate the hoses and gear, close the gauge valve and quickly test pressure of the pump only with the engine at warm idle, then open the valve to avoid increasing oil temperature. A minimum pressure of 1000 psi should be present with valve closed.</p> <p>(e) Comparing the maximum pressure obtained in these two tests will indicate source of trouble as follows: Step (b) pressure low and Step (d) pressure normal indicates faulty external oil lines or steering gear. Step (b) and Step (d) pressures equally low indicates faulty oil pump.</p>
<p>5. Low oil pressure in gear caused by restriction in hoses.</p> <p>(a) Check for kinks in hoses.</p> <p>(b) Foreign object in hose.</p>	<p>(a) Remove kink.</p> <p>(b) Remove hoses and remove restricting object or replace hose.</p>
<p>6. Low oil pressure due to steering gear.</p> <p>(a) Leakage at side cover "O" ring, housing end plug "O" ring, pitman shaft seals.</p> <p>(b) Pressure loss in cylinder due to worn piston ring, damaged back-up "O" ring or scored housing bore.</p> <p>(c) Leakage at valve rings, valve body to worm seal, rack-piston end plug seal.</p> <p>(d) Loose fit of spool in valve body or leaky valve body.</p>	<p>(a) Replace defective seals.</p> <p>(b) Remove gear from car for disassembly and inspection of rings and housing bore.</p> <p>(c) Remove gear from car for disassembly and replace seals.</p> <p>(d) Replace rotary valve assembly.</p>
<p>7. Incorrect installation or operation of the gear check poppet valve.</p>	<p>7. To determine if the poppet valve is installed and operating correctly, disconnect the pressure hose and install a pressure gage between the hose and the pump. With the engine at warm idle (525 RPM) and no effort on the steering wheel, oil pressure should not exceed 60 psi with warm oil. If gage indicates more than 60 psi the poppet valve should be checked for correct installation. Paragraph 90-18, subparagraph c, Step 6.</p>
<p>j. <b>NO EFFORT REQUIRED TO TURN</b> Broken torsion bar.</p>	<p>Replace rotary valve assembly.</p>

## DIVISION II

### DESCRIPTION AND OPERATION

#### 90-8 DESCRIPTION OF POWER STEERING GEAR

All series power steering gears are basically the same except for the following differences:

1. All 45-46-48-49000 Series gears have a snap ring located at the upper end of the housing which serves as a stop for the rack-piston nut assembly.
2. LeSabre with 455 engine, Centurion, Electra, and Riviera steering gears have a larger diameter rack-piston assembly which is required on these heavier cars to give the desired steering effort. This necessitates the use of a different housing.

The power steering gear gives precise, positive steering with very little driver effort. Initial hydraulic assist is obtained with approximately .3 degrees of steering wheel rotation and one pound of effort at the steering wheel rim.

Full hydraulic assist is obtained with approximately 4 degrees of wheel rotation and 3-1/4 pounds of effort at the wheel rim.

Manual steering is always available at times when the engine is not running, or in the event of pump failure. Of course, steering effort is increased under such conditions.

The driver's effort on the steering wheel is always proportional to the force necessary to turn the front wheels. When the effort on the wheel drops to less than one pound, power assistance ceases.

The upper inner end of the pitman shaft has a gear sector in mesh with a gear on the rack-piston nut. The one-piece rack-piston nut serves as a nut for the recirculating balls and as a power piston to which the oil under pressure is applied. A Teflon piston ring, backed-up by an "O" ring, are located on the lower O.D. of the rack-piston nut, and serve as a seal between the rack-piston nut and the gear housing. See Figure 90-16.

A worm shaft turns in the rack-piston nut using selectively fitted steel balls as a rolling thread. The ball groove is more shallow in the center of the worm so that when the

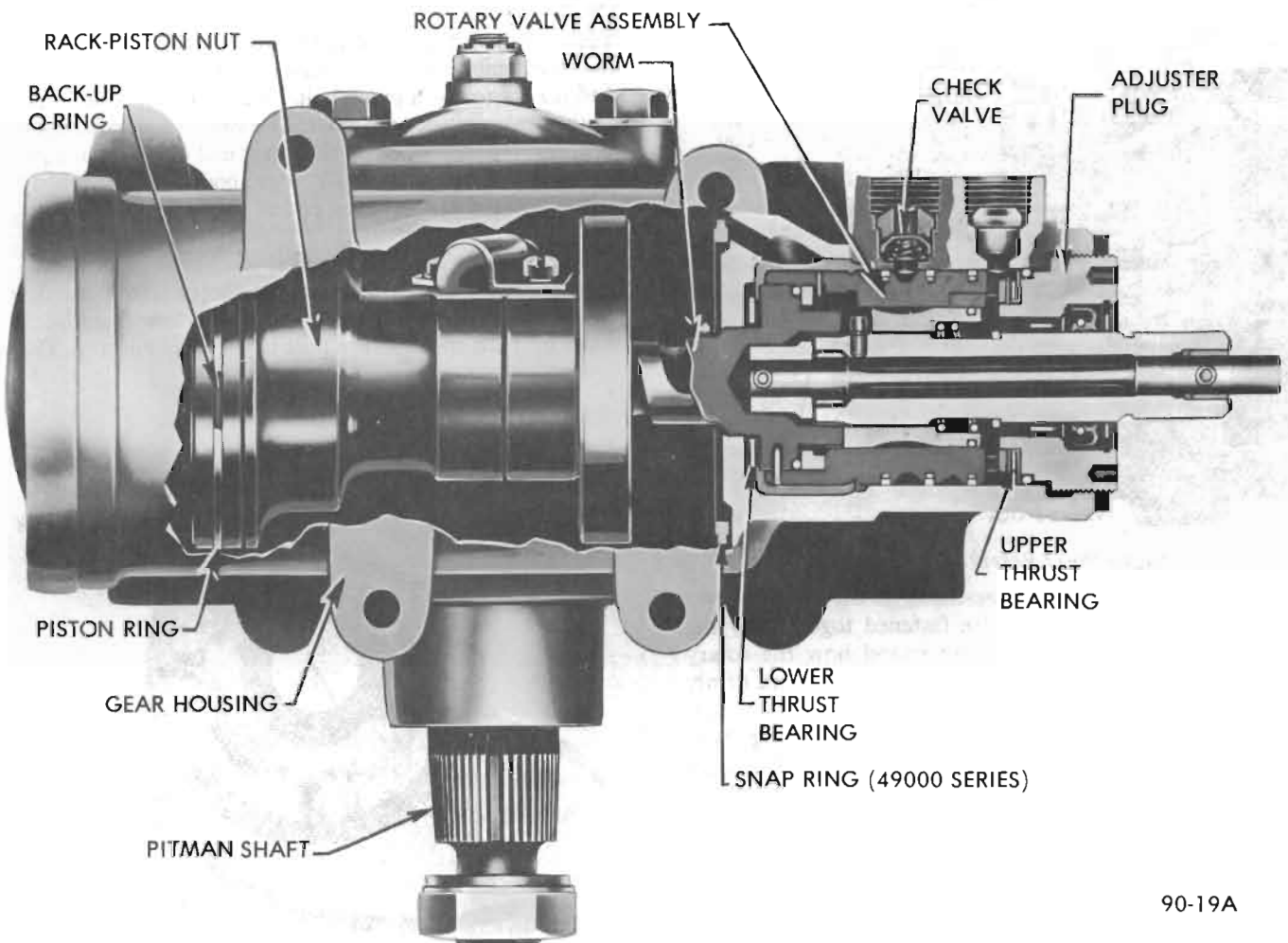

Figure 90-16 Power Steering Gear - Cutaway

proper size balls are used, there is a slight worm to rack-piston nut preload in the straight-ahead position.

Worm shaft end thrust is caused by the tendency of the worm to thread itself into or out of the rack piston nut as the steering wheel is turned right or left. The end thrust is absorbed entirely by the upper and lower thrust bearings. The upper thrust bearing is located between the valve body and adjuster plug, and the lower thrust bearing is located between the housing and upper end of worm. Worm shaft radial loads are transmitted to the gear housing through the rack-piston nut.

The steering shaft is connected to the power steering gear through a flexible coupling which is bolted to the steering shaft flange. This flexible coupling helps absorb minor shocks and vibrations and dampens out hydraulic noises and gear assembly vibrations.

The rotary valve assembly is located in the upper section of the gear housing and consists of a stub shaft, torsion bar, valve body, valve spool, and valve body cap. The rotary valve assembly controls the flow of oil from the pump to the proper side of the rack-piston nut when power assistance is required and cuts off this flow when power assistance is not required. See Figure 90-17.

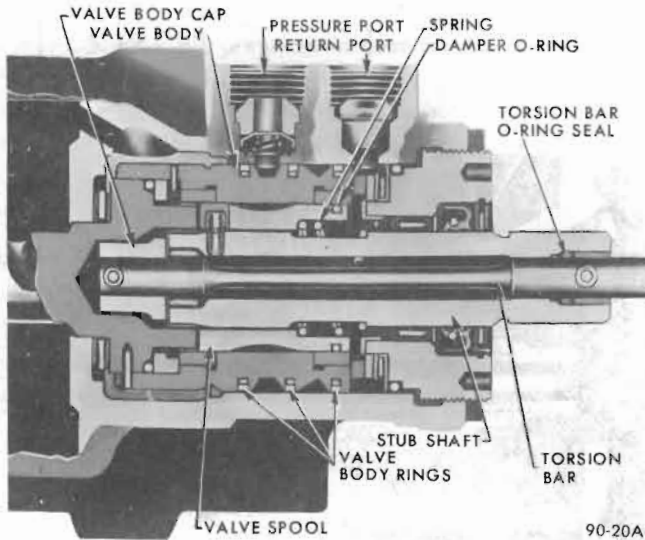

Figure 90-17 Rotary Valve Assembly

Basically the rotary valve assembly is divided into two separate assemblies which are fastened together by the torsion bar. To completely understand how the rotary valve functions, it must be known what parts are firmly connected together. Starting with the stub shaft which is fastened to the steering wheel through the steering shaft, the first assembly consists of the stub shaft, valve spool and upper end of the torsion bar. A pin on the outside diameter of the stub shaft retains the valve spool to the stub shaft. A pin at the upper end of the stub shaft connects the upper end of the torsion bar and stub shaft together. See Figure 90-18.

The balance of the assembly which is connected to the front wheels of the car through linkage, pitman shaft and

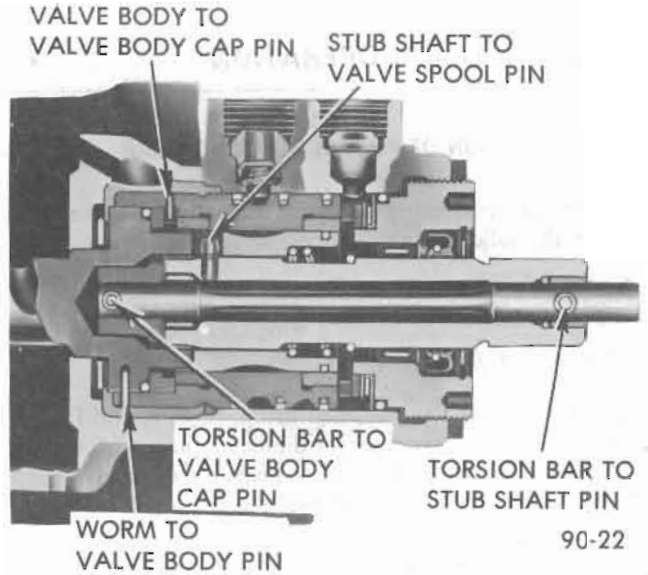
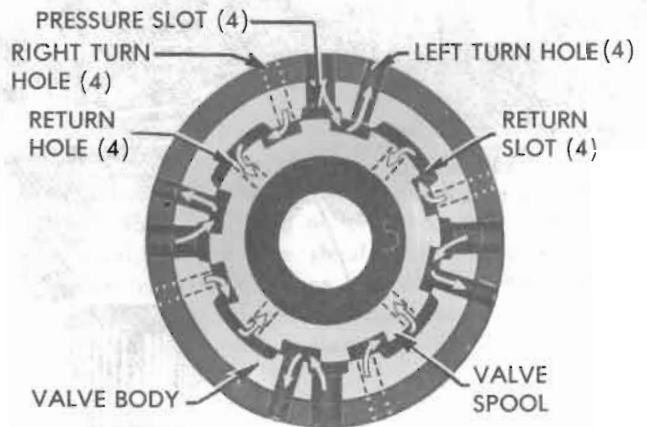

Figure 90-18 Attaching Pins for Rotary Valve Parts

rack-piston nut, consists of the worm, valve body, valve body cap and lower end of the torsion bar.

The stub shaft is attached to the steering shaft through the flange assembly. The lower flange is splined to a stub shaft and is retained by a pinch bolt. The torsion bar is located in the center of the stub shaft. The valve spool is an open center valve positioned on the lower end of the stub shaft. The valve body encloses the valve spool. The valve body cap is located at the lower end of the valve body.

The valve body has two large oil grooves around its outside diameter. Each groove has four holes drilled into the inside diameter of the valve body. The lower groove is lined up with the pressure port in the gear housing. The



90-21

Figure 90-19 Rotary Valve - Left Turn (Upper End View)



upper groove is lined up with a drilled passage in the housing which directs oil to the right turn chamber in the housing, located at the lower end of the rack-piston nut. Three teflon rings on the valve body provide leak-proof seals for the oil grooves on the valve body. The inside diameter of the valve body has eight slots, four are connected to the pressure groove by the four drilled holes. See Figure 90-19. The other four slots, which are wider, are connected to the return port in the housing through the valve spool. Near the center of the valve body are four other drilled holes which are used to direct oil to a passage in the housing that opens to the left turn chamber. This chamber is located at the upper end of the rack-piston nut.

The valve spool which fits inside the valve body may have an outside diameter as close as only .0004 in. smaller than the inside diameter of the valve body. This close fit allows very little, if any, oil flow between the two surfaces. The valve spool has four holes drilled near the upper end of it which are in line with the four return slots in the valve body. These holes allow oil to flow from the return slots in the valve body to the center of the spool and on to

return port in the housing. The outside diameter of the spool has eight slots machined on it, four are for opening the right turn holes in the valve body to the pressure slots or to the return slots in the valve body. The other four slots on the spool serve the same function for the left turn holes in the valve body.

The worm is attached to the valve body by a pin located at the upper end of the worm. A pin on the inside diameter of the valve body connects the valve body cap to the valve body. To complete this assembly, a pin attaches the valve body cap to the lower end of the torsion bar. When there is resistance to turning between the roadbed and the wheels of the car, the parts connected to the worm will also resist turning. Thus when the steering wheel is turned by the driver, the torsion bar will deflect and allow the stub shaft and valve spool to rotate with the steering wheel. When this occurs, the relationship between the valve spool and valve body is changed. The oil flow is directed by the slots on the valve spool through the holes in the valve body to the proper side of the rack-piston nut to assist the driver. The torsion bar deflection is limited to

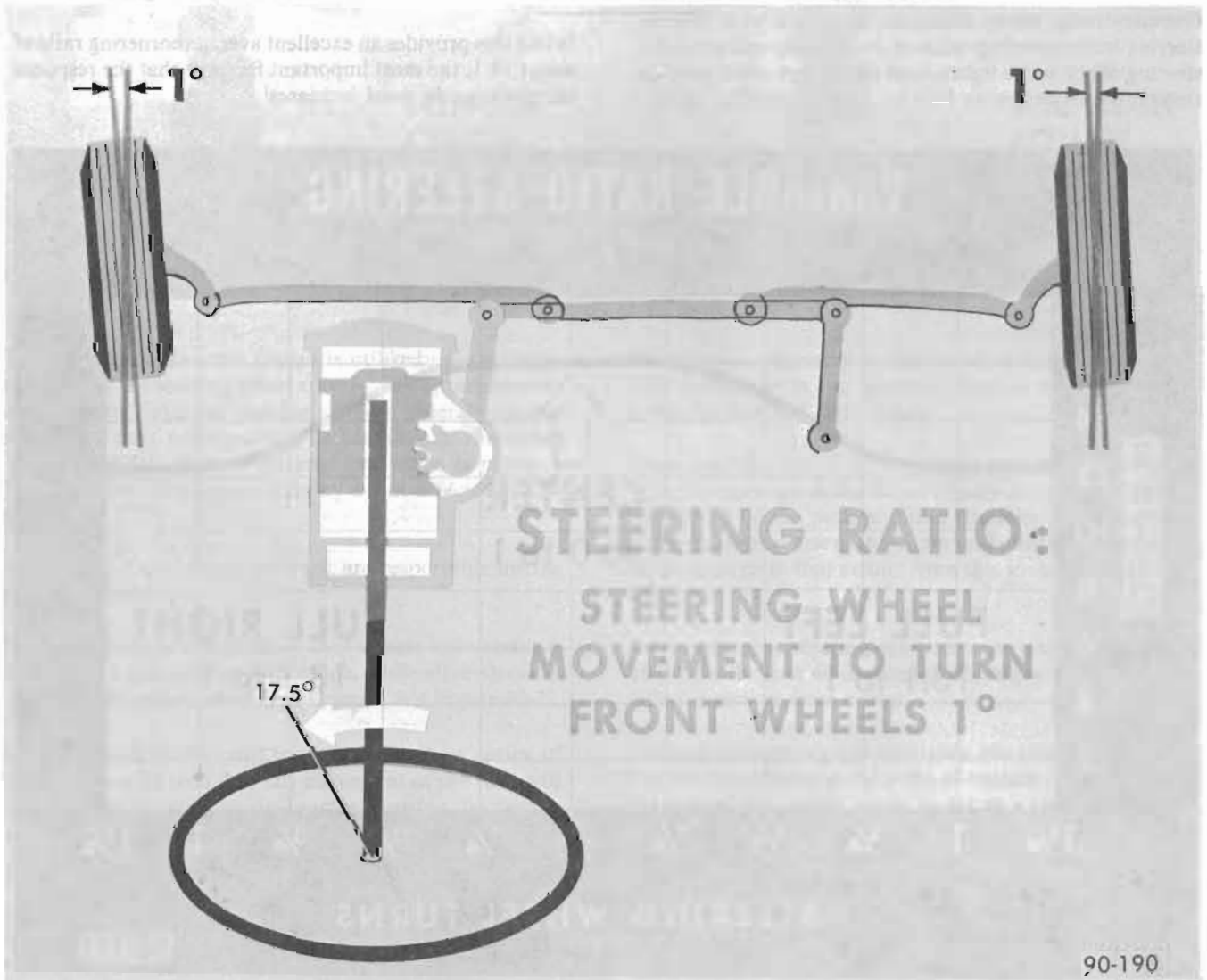

Figure 90-20 - Steering Ratio

a predetermined amount. The upper end of the worm has two tangs which fit through slots in the valve body cap and into two slots in the end of the stub shaft. In case of a power mechanism failure, the stub shaft will contact the tangs of the worm and steering will be manual.

**b. Variable Ratio Feature (All Series)**

The ratio of a steering system is the relationship of steering wheel movement to that of the front wheels - that is, the amount, in degrees, that the steering wheel must be turned to turn the front wheels one degree. See Figure 90-20.

For example, previous Buicks had a steering ratio of 17.5:1, and since that was a constant ratio gear, it was necessary to turn the steering wheel approximately 17.5 degrees for each degree of turn desired.

Part of this ratio is developed in the linkage, but the greatest part of the overall ratio is developed in the steering gear itself.

Comparatively, many American-built cars with manual steering utilize steering ratios of 28:1 to help minimize the steering effort, while lightweight sports cars often provide steering ratios as low as 10:1 for greatest turning agility.

While the terms are not specific, cars with low ratio steering are often referred to as "fast" or "quick" steering because of the car's fast response to steering wheel movements. The term "slow" steering is less frequently heard, but is sometimes applied to cars with higher steering ratios.

Steering ratio varies continuously from a moderate 16.0:1 or 15.0:1 for straight-ahead driving to a low 13.1:1 in full turns.

From the straight-ahead position, the steering ratio stays constant for the first 40 degrees of steering wheel movement, then decreases very gradually at first. This provides precise steering control for highway driving with a ratio always higher than 15:1, as passing or even steering through curves seldom requires more than a quarter turn of the steering wheel.

When cornering, such as at an intersection, the ratio spread will be somewhat broader - anywhere between 16:1 and 13.1:1 -- as the steering necessary generally ranges from a half to a full turn of the steering wheel.

While this provides an excellent average cornering ratio of about 14:1, the most important factor is that the response increases as the need increases!

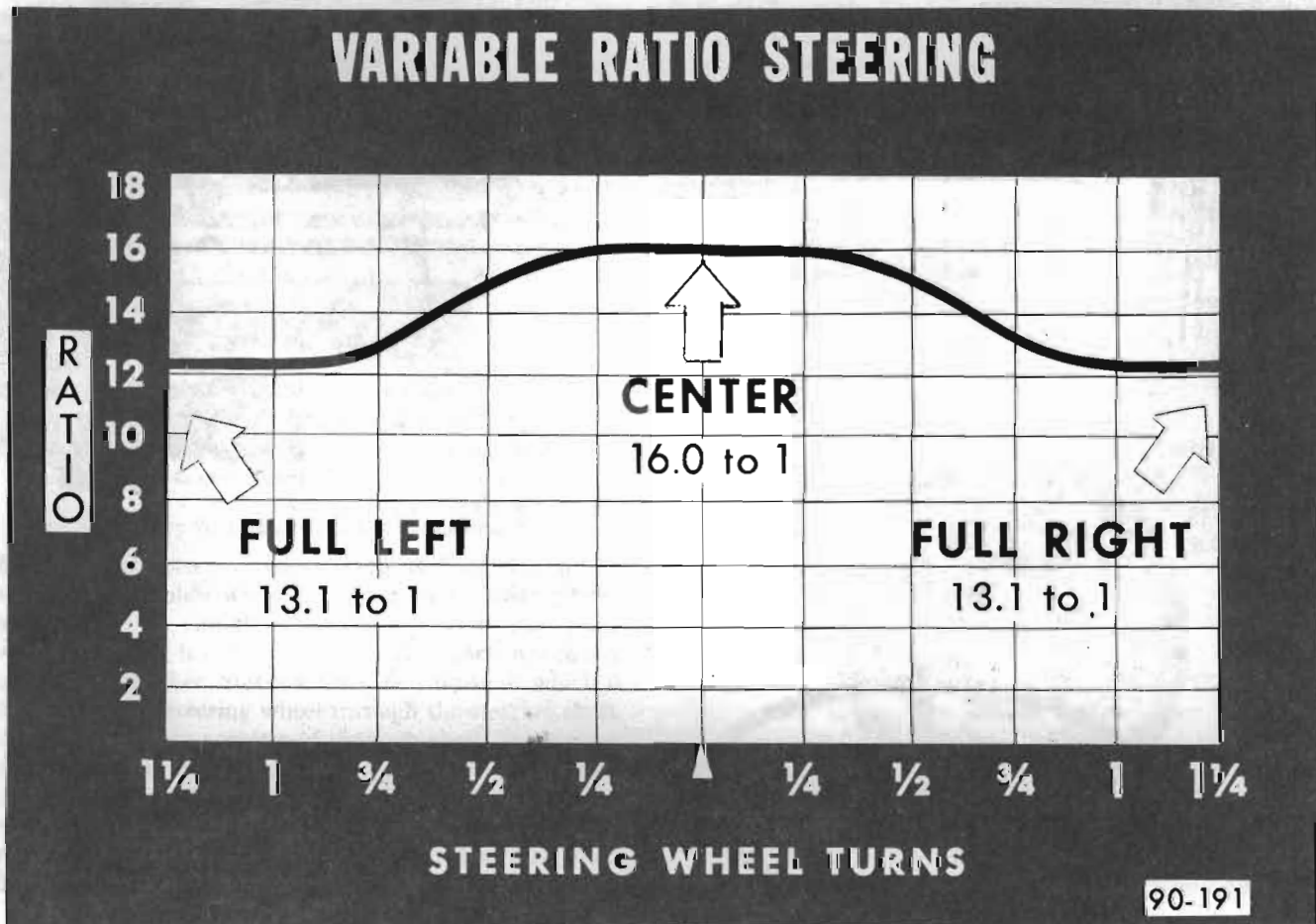

Figure 90-21 - Variable Ratio Steering

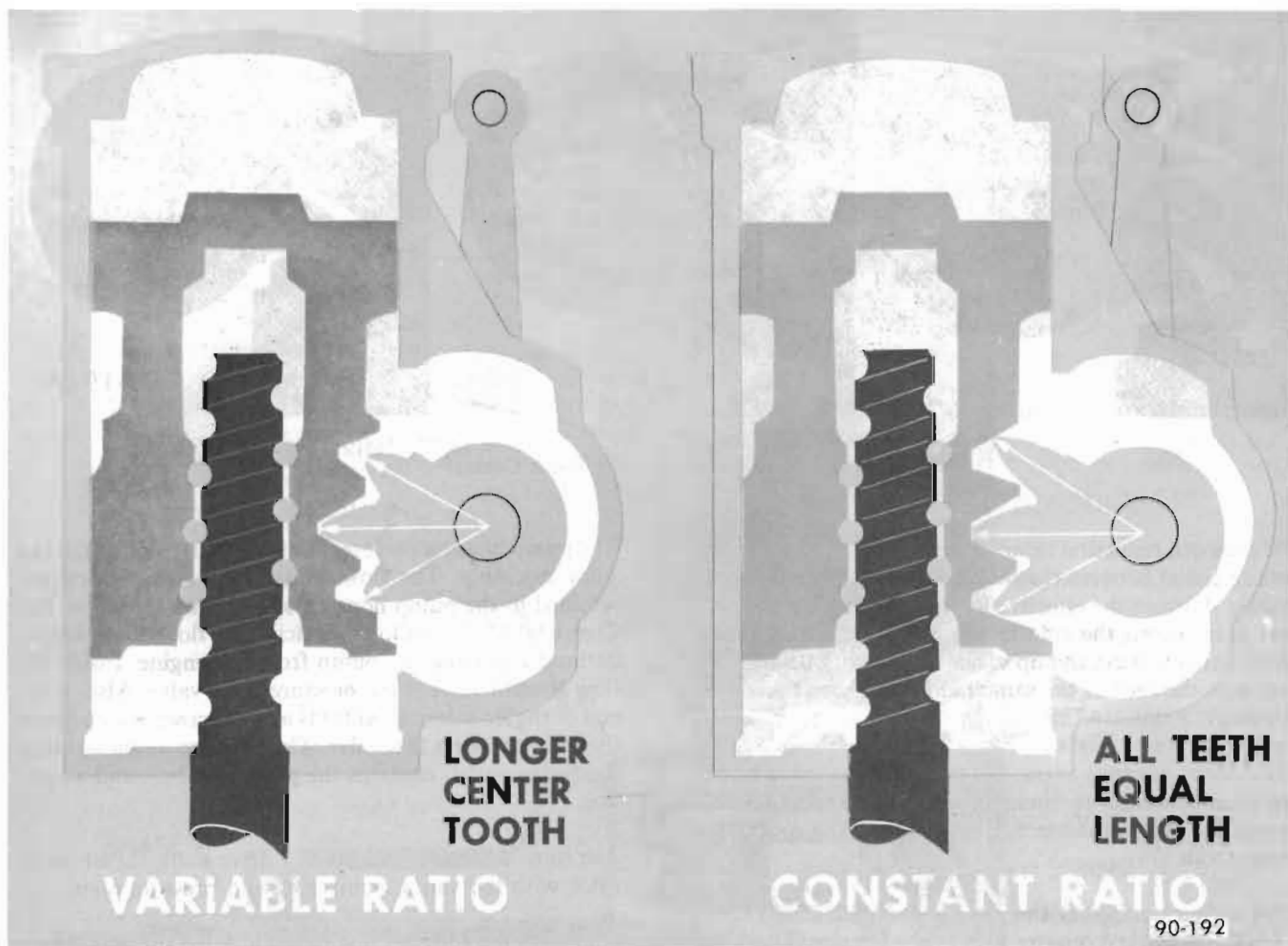

Figure 90-22 - Steering Gear Tooth Design

The low end of the ratio spread is utilized only near the extremes of the steering wheel travel--after approximately one full turn. Since the steering wheel is generally turned to its limit only when parking or backing up, the added maneuverability of these extreme low ratios is purely a "bonus", since directional stability is not a factor at low speeds.

The design of the sector and rack are responsible for the steering flexibility.

Notice that the center tooth of the variable ratio sector is longer than the teeth on either side, while all teeth of the conventional sector are of equal length. See Figure 90-22.

Since the sector, like any gear, is basically a series of levers, it is easily seen that any movement of the rack will always cause the conventional sector to swing the pitman arm in the same ratio--that is, to turn the pitman arm the same number of degrees with each tooth in the sector.

To increase or decrease the ratio, it is only necessary to change the length of the sector teeth, and we see that a low ratio, or smaller radius sector with shorter teeth, produces a greater pitman arm movement than the high ratio sector with its longer teeth and greater leverage.

On this basis, the variable ratio sector is in reality one long high ratio lever at the center flanked by two lower ratio levers for left and right turns.

Since only the tip of the long center tooth is in contact with the rack when the front wheels are straight, initial movement of the rack in either direction causes a relatively small response of the sector and pitman arm because of the high ratio that results from this long lever relationship.

As a result, the steering ratio remains a nearly constant 16.0:1 for the first 40 degrees of steering wheel movement either direction from center.

Turning the steering wheel further, the effective length of the lever is reduced as the point of contact now rolls down the side of the center tooth, to act as a shorter radius.

As a result, the steering ratio is reduced, causing the pitman arm to move noticeably further for a given steering wheel movement. With the wheel turned one-half turn, the steering ratio is reduced to approximately 14.2:1.

With a three-quarter turn of the steering wheel, the leverage has been further reduced to approximately 13.3:1.



Figure 90-23 - Steering Gear Tooth Contact

This smooth reduction in steering ratio is produced by the rolling action between the rack and center tooth that constantly shortens the effective leverage by moving the contact point down the side to the root of the long center tooth. At this time, the tip of the short tooth begins contact with the rack at the same radius and soon takes over the load.

From three-quarters to one full turn of the steering wheel, the ratio continues to diminish as the same rolling action moves the point of contact from the tip to the root of the short tooth.

This action completes the ratio reduction from 13.3 to 13.1:1. For the last quarter turn of the steering wheel, the ratio remains constant at 13.1:1 to provide greatest maneuverability for backing and parking.

### 90-9 DESCRIPTION OF POWER STEERING OIL PUMP AND HOSES

The oil pump, which is mounted on the engine in position to be driven by a belt from the crankshaft balancer, converts some engine power into oil pressure which is used against the rack-piston nut to rotate the pitman shaft.

Three different pump assemblies are provided for the 1971 Models. These pumps are identical except for the rotor, thrust plate, vanes, pump ring, pressure union and reservoir shape.

The pump used on 45-46-48-49000 Series cars with 455 cu.in. engines has a thicker rotor, pump ring, and vane assembly for increased output.

The pump reservoir encloses the pump housing and provides a reserve supply of oil to assure complete filling of the hydraulic system. See Figure 90-24.

The reservoir cap is vented which permits escape of any air that may be introduced into the system during assembly of the various units and maintains atmospheric pressure in the reservoir.

The pump housing encloses the flow control valve and the rotor assembly. The flow control valve and spring are retained in the pump housing by the pressure union. See Figure 90-25. This allows servicing the flow control valve without removing the pump from the engine. Inside the flow control valve is the pressure relief valve. Also in the end of the flow control valve is a filter screen which filters the oil that enters this valve. The pressure union which is the pump outlet, contains the pump exit hole and an orifice.

The rotor assembly consists of a drive shaft, thrust plate, rotor with ten vanes, pump ring and pressure plate.

Oil enters the rotor section of the housing through a hole which is open to the surrounding reservoir.

The rotor which is loosely splined to the end of the drive shaft, is located adjacent to the face of the thrust plate and is enclosed by the pump ring. The rotor vanes slide radially outward to contact the hardened and ground inside cam surface of the ring. See Figure 90-26.

As the shaft and rotor rotate, centrifugal force and fluid pressure against the inner ends cause the vanes to follow the cam contour of the ring. The cam surface is so shaped that two opposite pumping chambers are formed which cause a complete pumping cycle to occur every 180 degrees of rotation of the rotor. The pump ring has two crossover passages drilled in it, which transfer oil from the thrust plate into a discharge cavity located at the rear of the pressure plate.

When the engine is started, each pumping chamber picks up oil from two openings, one between the pressure plate and ring and the other between the thrust plate and ring. See Figure 90-24. The oil is then propelled by the decreasing pockets in each pumping chamber into the discharge cavity through an opening in the pressure plate and an opening in the thrust plate which is connected to the crossover passage in the ring. The oil flows from the discharge cavity into a passage which is open to the rear of the flow control valve and to the exit hole in one end of

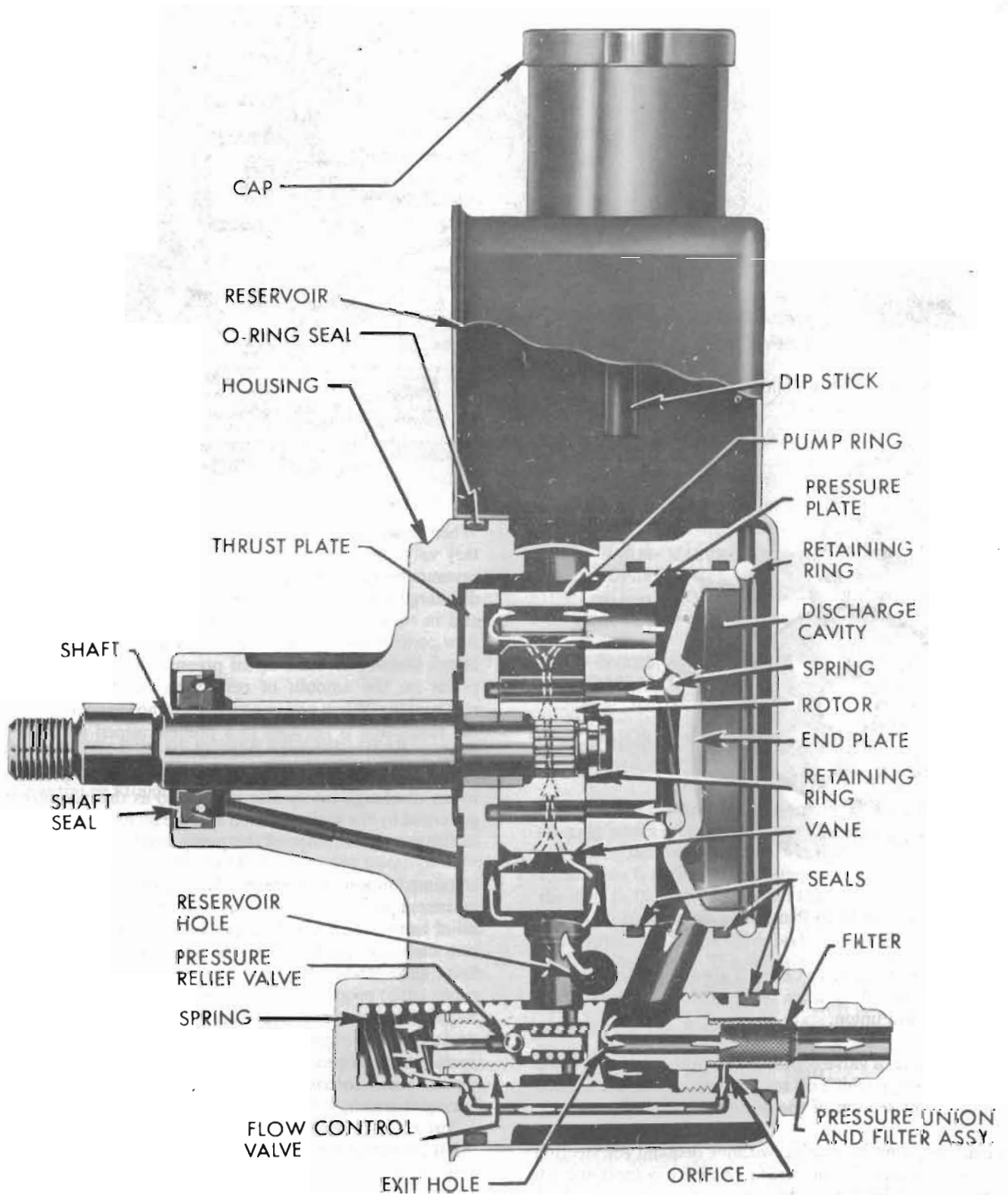

90-133A.

Figure 90-24 Oil Flow in Pump

the pressure union. Oil flows through the outlet end of the pressure union to the steering gear assembly. Some oil flows through the orifice in the pressure union and into a

passage in the pump housing which directs oil into the spring chamber located in front of the flow control valve.

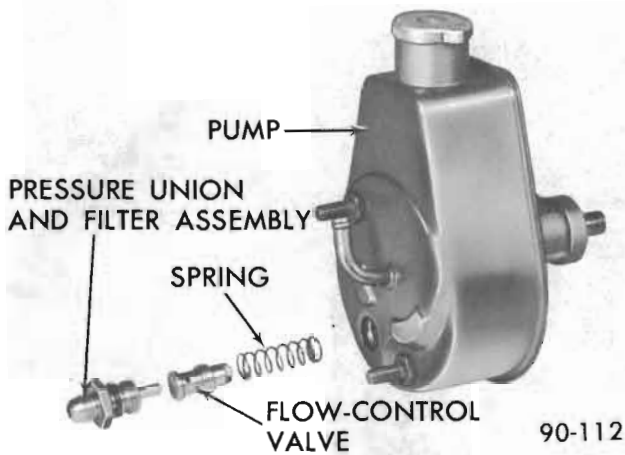

Figure 90-25 Flow Control Valve Installation

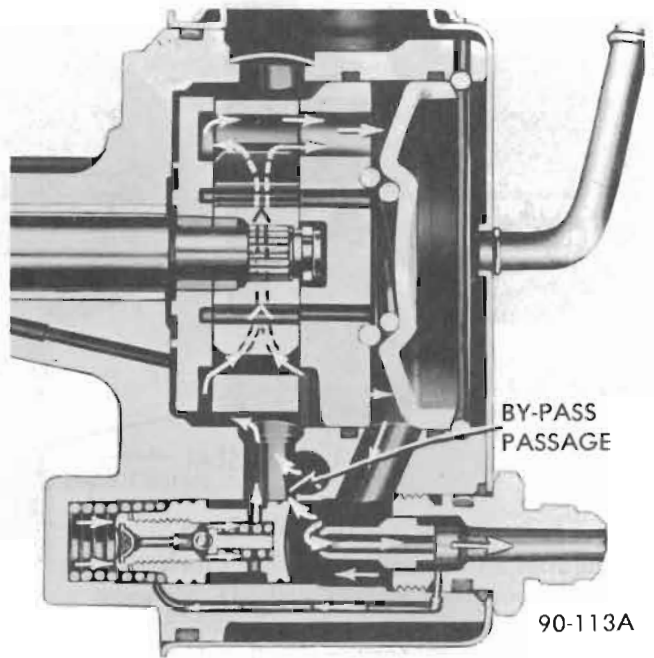

Figure 90-27 Flow Control Valve Operation

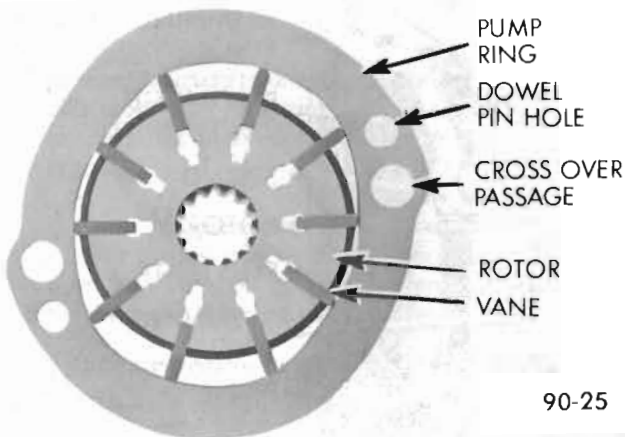

Figure 90-26 Pump Ring and Rotor

Pressure in the discharge cavity is always greater than the pressure of the oil that has passed through the exit hole in the pressure union.

The flow control valve regulates the opening of a by-pass passage through which oil may be returned to the suction and reservoir section of the pump.

When the pump is running without demand for steering pressure, pressure in the discharge cavity is great enough to push the flow control valve open against a spring load of approximately ten pounds. See Figure 90-27. The pressure in the spring chamber tends to close the valve, but since pressure in the discharge cavity is always greater than in the spring chamber, the valve is not closed. The movement of the valve is controlled by the spring tension and the difference in pressure on the front and rear side of the valve.

When power assistance is required, the steering gear rotary valve restricts free circulation of oil, and the pump pressure builds up rapidly. As the pressure increases in the discharge cavity it also increases in the spring chamber and in turn additional pressure is required to move the flow control valve to open the by-pass passage. The maximum amount of build-up of pressure by the pump depends on the amount of restriction controlled by the rotary valve. When power assistance is no longer required, the restriction is reduced to a predetermined minimum. With a small amount of restriction, the pressure in the spring chamber drops to a minimum. Thus, the pressure in the discharge cavity also is reduced as this pressure is governed by the spring tension and the oil pressure present in the spring chamber of the pump.

If pump output pressure reaches 1100 to 1200 psi, the increased pressure in the spring chamber forces a pressure relief valve open and oil escapes from the spring chamber into the by-pass hole around the pressure relief valve ball. See Figure 90-27.

As oil pressure is relieved in the spring chamber, the high pressure in the pump discharge cavity overcomes the spring load to open the flow control valve. Because outlet pressure has to pass through an orifice to get into the spring chamber, the pressure in the spring chamber drops below outlet pressure for a fraction of a second. This allows the flow control valve to be open enough to lower line pressure to a safe level immediately. Oil is then pumped into the by-pass passage until the line pressure opposing the pump drops below the relief valve setting, permitting this valve to close. The flow control valve then resumes normal operation.

The flow control valve starts to open at 300-400 RPM of pump and is functioning when the pump is running 465 RPM (400 RPM of engine).

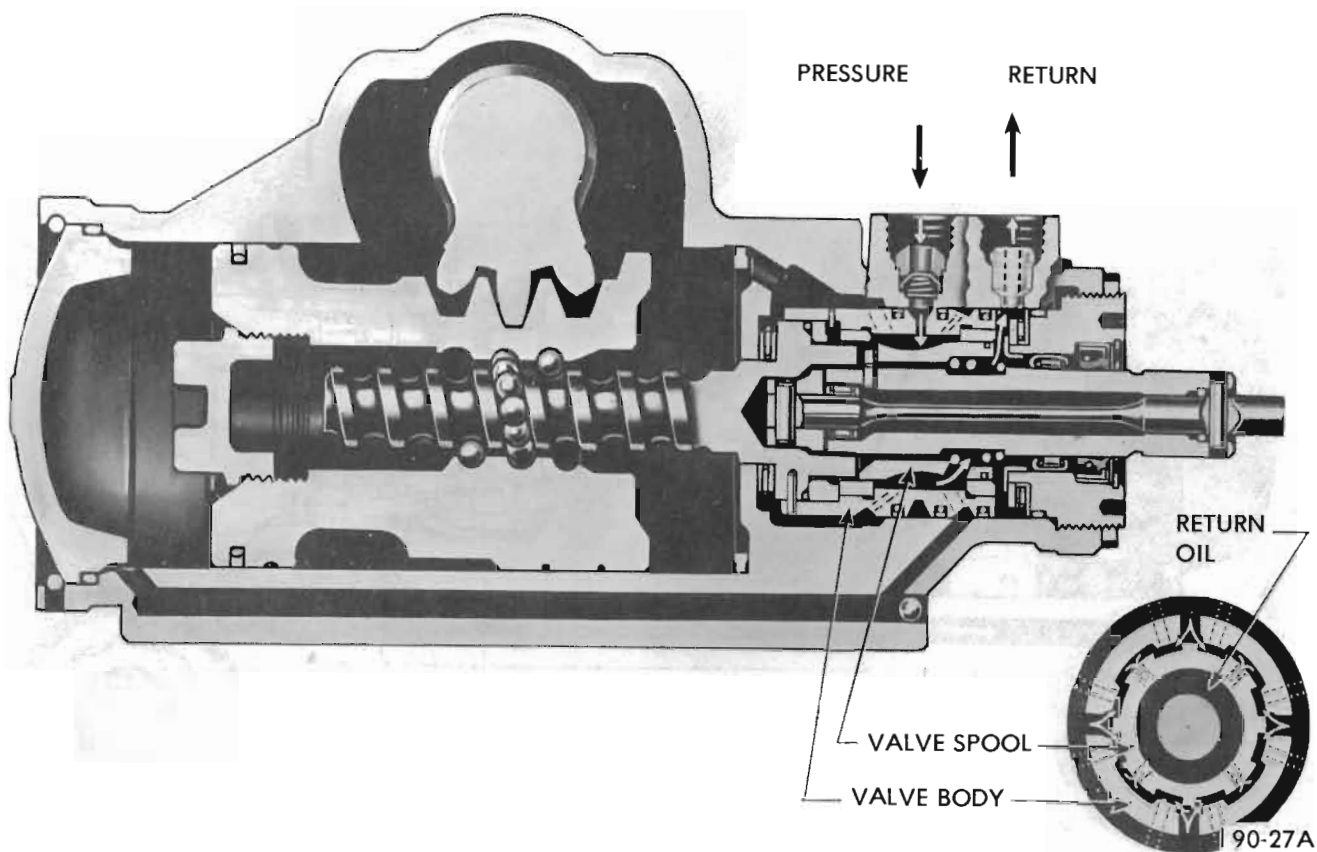

Figure 90-28 Oil Flow in Power Steering Gear (Straight-Ahead Position)

## 90-10 OPERATION OF POWER STEERING GEAR

### a. Neutral or Straight-Ahead

Figure 90-28 shows the rotary valve in the neutral or straight-ahead position. Oil flows from the pump into the pressure port of the gear, through the open center valve spool and back to the pump reservoir through the return port. The slots on the valve spool are so positioned in the valve body that the oil entering through the pressure port is directed to the return slots in the valve body, then through the center of the spool which is open to the return port. There is no flow to either side of the rack-piston nut, but both sides are full of oil at all times. In the straight-ahead position the pressure on both sides is equal. The oil acts as a cushion that absorbs road shocks so they are not transferred to the steering wheel, thus giving safer and more effortless driving. In addition, this oil lubricates all the internal components of the gear.

All passages in the gear are open in the straight-ahead position and the valve remains in this position at all times except when effort applied to the steering wheel is more than one pound. The open center design of the rotary valve reduces pump losses to a minimum by allowing a minimum of restriction to oil flow in the straight-ahead position.

### b. Right Turn

Figure 90-29 illustrates the operation of the gear when the steering wheel is turned to the right. Due to the resistance of turning between the front wheels and the roadbed, the torsion bar is deflected, changing the relationship between the slots in the valve spool and the slots in the valve body. The right turn slots on the valve spool are closed off from the return slots in the valve body and are opened more to the pressure slots. The left turn slots of the spool are closed off from the pressure slots and opened more to the return slots. This causes oil to flow into the right turn chamber of the housing and force the rack-piston nut upward. As the rack-piston nut moves upward, it applies turning effort to the pitman shaft.

The oil in the left turn chamber in the housing is simultaneously forced out through the valve and back to the pump reservoir. The higher the resistance to turning between the roadbed and the car wheels, the more the position of the valve spool is changed in relation to the valve body and the higher the oil pressure on the lower end of the rack-piston nut. Since the amount of hydraulic pressure directed to the right turn chamber is dependent upon the resistance to turning, the driver is assured of the proper amount of smooth hydraulic assistance at all times.

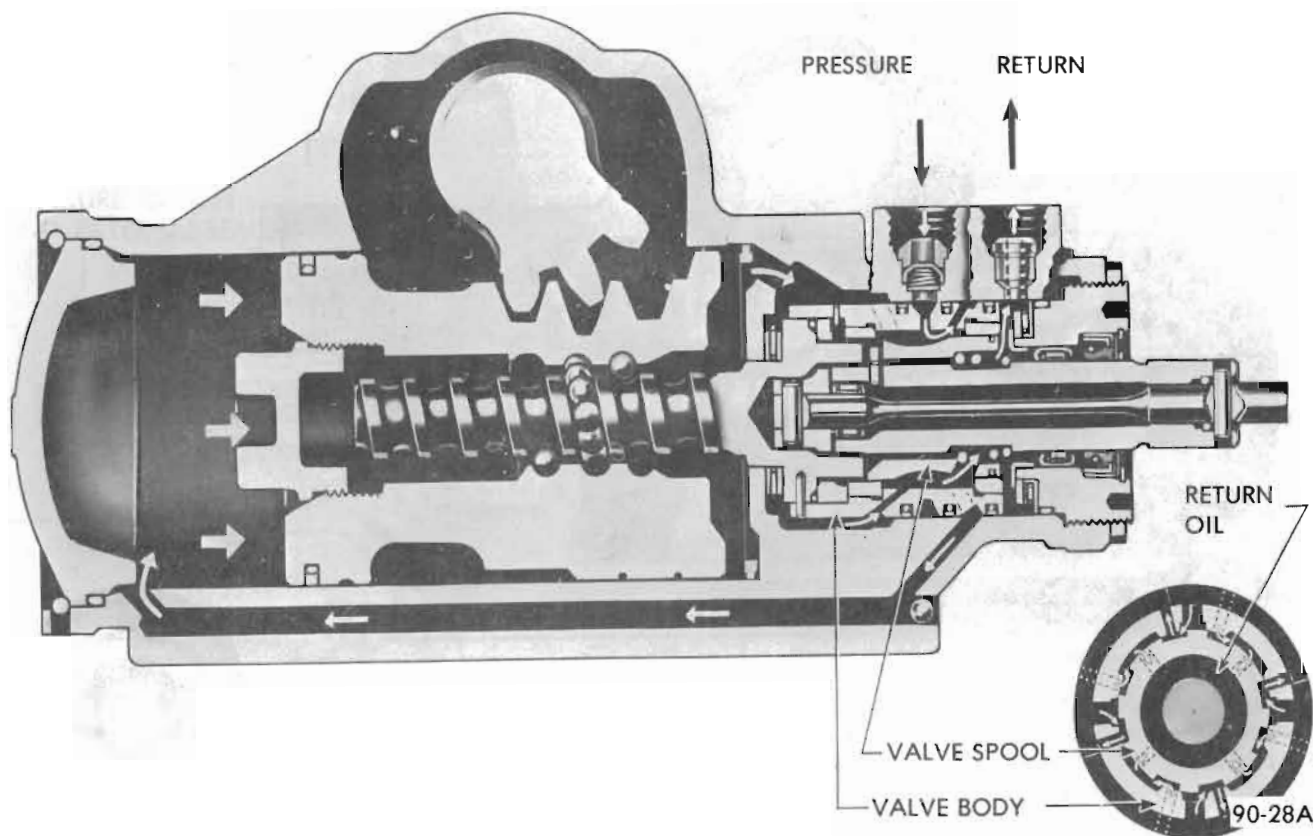

Figure 90-29 Oil Flow in Power Steering Gear (Right Turn)

The instant the driver stops applying steering effort to the steering wheel, the valve spool is moved back into its straight-ahead position in the valve body by the torsion bar.

When this happens, the oil pressure is again equal on both sides of the rack-piston nut, and the steering geometry of the car causes the wheels to return to the straight-ahead position.

#### c. Left Turn

Figure 90-30 illustrates the operation of the gear when the steering wheel is turned to the left. The resistance to turning of the front wheels causes the torsion bar to deflect, changing the relationship between the valve spool slots and the valve body slots. The slots are reversed from the right turn position and change the flow of oil into the left turn chamber in the housing, moving the rack-piston nut downward. Thus, turning effort is applied to the pitman

shaft. The oil in the right turn chamber is forced through the valve and back to the reservoir. When the driver stops applying steering effort, the valve spool returns to the straight-ahead position.

#### d. Check Valve Poppet

The check valve is located in the pressure port of the housing under the connector. The valve consists of a poppet and a spring and its purpose is to reduce the possibility of steering wheel "kickback". If when making a turn, the front tire hits a bump which forces it in a direction opposite the turn, the impact will be carried up to the rack-piston nut by the pitman shaft. If the force is great enough, the rack-piston nut will tend to move against the applied oil pressure and force oil back through the valve assembly and out through the pressure port where the poppet valve is now located. If the rack-piston moved in the opposite direction, the steering wheel would resist momentarily or would "kick-back". The poppet valve is designed to prevent the above action from occurring by trapping the oil inside the gear.



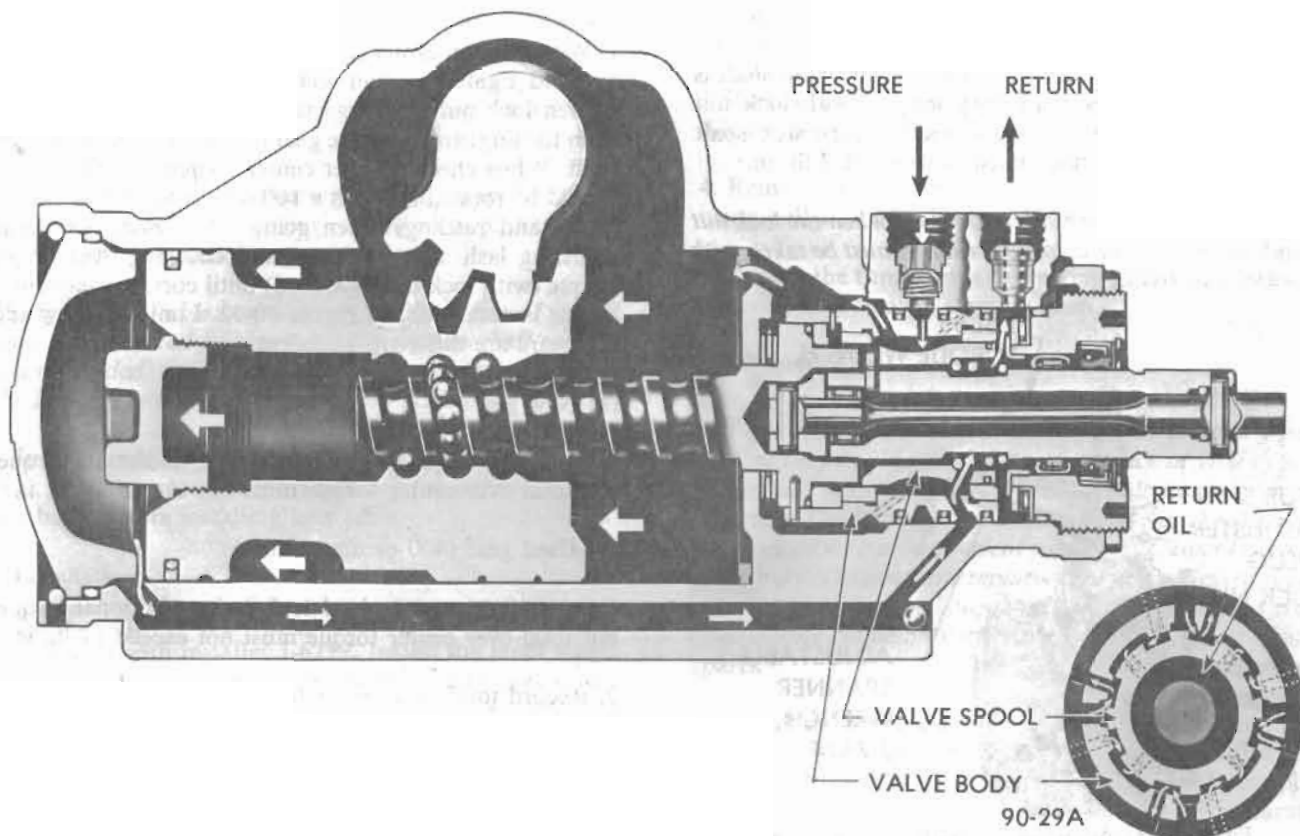

Figure 90-30 Oil Flow in Power Steering Gear (Left Turn)

## DIVISION III

### ADJUSTMENTS AND MINOR SERVICE

#### 90-11 ADJUSTMENT OF POWER GEAR

Adjustment of the steering gear in the car is discouraged because of the difficulty encountered in adjusting the worm thrust bearing preload and the confusing effects of the hydraulic fluid in the gear. Since a gear adjustment is made only as a correction and not as a periodic adjustment, it is better to take the extra time and make the adjustment correctly the first time.

Since a handling stability complaint can be caused by improperly adjusted worm thrust bearings as well as an improper gear over-center adjustment, it is necessary that the steering gear assembly be removed from the car and both thrust bearing and over-center preload be checked and corrected as necessary. An in-car check of the steering gear will not pin-point a thrust bearing adjustment error.

##### a. Initial Checks

1. Remove gear from car.

2. Drain oil from gear by rotating through its travel several times.

3. Check gear adjustment torque as removed from car as follows:

- (a) One-half turn off right and left stops.
- (b) One-half turn off center-right and left.
- (c) Over center (rotate through an arc 180 degrees each side of center) - right and left.

##### b. Worm Thrust Bearing Adjustment

1. Loosen pitman shaft lash adjuster screw lock nut.
2. Back off pitman shaft lash adjuster screw 1-1/2 turns and retighten lock nut.
3. Loosen thrust bearing adjuster plug lock nut.
4. Back off thrust bearing adjuster plug 1/2 turn and retighten lock nut.
5. Turn gear stub shaft to right stop and then back 1/2 turn.

6. Using an inch pound torque wrench on gear stub shaft, measure drag torque.

7. Tighten adjuster plug until torque to turn stub shaft is 3 to 4 lb. in. greater than drag torque (with lock nut tightened). See Figure 90-31. Torque to turn stub shaft (drag plus thrust bearing) must not exceed 7 lb. in.

**NOTE:** Preload torque tends to drop off when the lock nut is tightened. Therefore, torque reading must be taken with the lock nut tight.

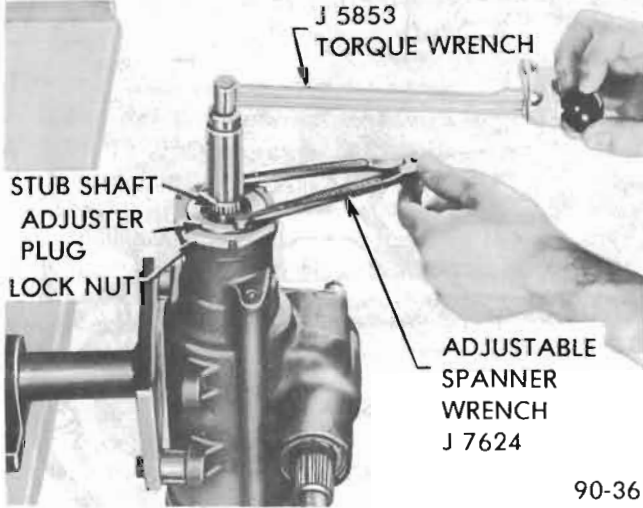

Figure 90-31 Adjusting Thrust Bearing Preload

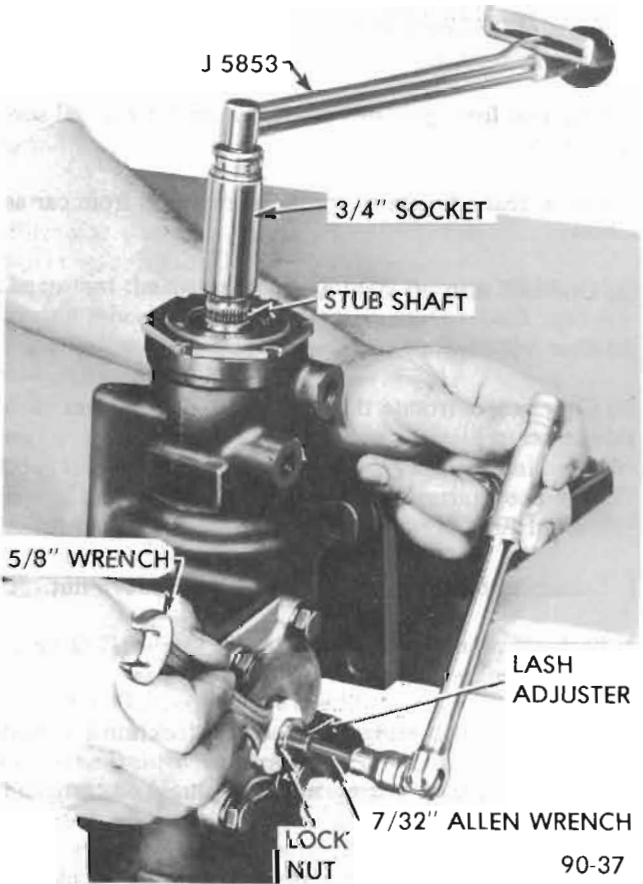

Figure 90-32 Pitman Shaft Over-Center Adjustment

**c. Pitman Shaft Over-Center Adjustment**

1. With gear on center, loosen pitman shaft adjuster lock nut and tighten pitman shaft lash adjuster screw. Retighten lock nut (holding lash adjuster screw to keep it from turning) and measure gear over center torque at stub shaft. When checking over center torque, torque wrench should be rotated through a 180 degree arc either side of center and readings taken going over center. Continue adjusting lash adjuster screw and checking over center torque (with lock nut tightened) until correct over center torque is obtained. See Figure 90-32. Limits for new and old gears are different, as follows:

(a) New gear.

Over center torque to be 8 to 10 lb. in. additional torque, but total over center torque must not exceed 18 lb. in.

(b) Used gear (400 or more miles).

Over center torque to be 4 to 5 lb. in. additional torque, but total over center torque must not exceed 14 lb. in.

2. Record total over center torque. This consists of over center, thrust bearing, and drag torque.

**90-12 REMOVAL AND INSTALLATION OF PITMAN SHAFT SEALS, GEAR IN CAR**

**a. Removal**

If, upon inspection of the gear, it is found that oil leakage exists at the pitman shaft seals, the seals may often be replaced without removing gear assembly from car as follows:

1. Remove pitman arm nut and disconnect pitman arm from pitman shaft using puller J-5504. See Figure 90-33.

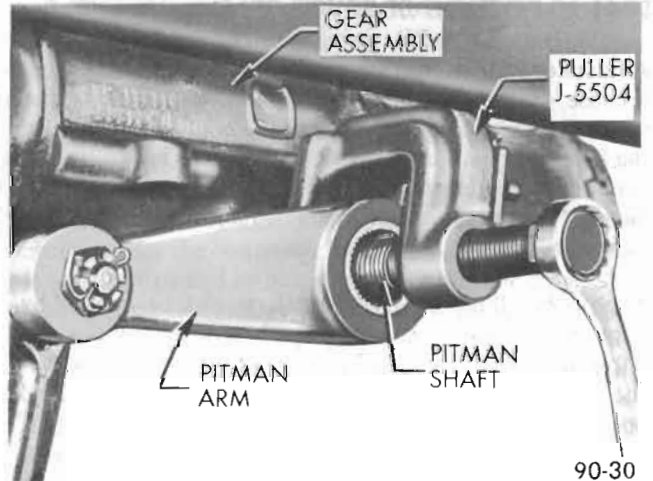

Figure 90-33 Removing Pitman Arm From Pitman Shaft.

2. Thoroughly clean end of pitman shaft and gear housing, then tape splines on end of pitman shaft to insure that seals will not be cut by splines during assembly.

**NOTE:** Only one layer of tape should be used; an excessive amount of tape will not allow the seals to pass over it, due to the close tolerance between the seals and the pitman shaft.

3. Remove pitman shaft seal retaining ring with No. 3 truarc pliers J-4245.

4. Start engine and turn steering wheel fully to the left so that oil pressure in the housing can force out pitman shaft seals. Turn off engine.

**NOTE:** Use suitable container to catch oil forced out of gear. This method of removing the pitman shaft seals is recommended, as it eliminates the possibility of scoring the housing while attempting to pry seals out.

5. Inspect seals for damage to rubber covering on O.D. If O.D. appears scored, inspect housing for burrs. Remove any burrs before installing new seals.

#### b. Installation

1. Lubricate the seals thoroughly with petroleum jelly and install seals with installer J-6219. Install the inner single lip seal first, then a back-up washer. Drive seal in far enough to provide clearance for the other seal, back-up washer and retaining ring. *Make sure that the inner seal does not bottom on the counterbore.* Install the outer double lip seal and the second back-up washer in only far enough to provide clearance for the retaining ring. Install retaining ring.

2. Fill pump reservoir to proper level. Start engine and allow engine to idle for at least three minutes without turning steering wheel. Turn wheel to left and check for leaks.

3. Remove tape and reconnect pitman arm. Tighten pitman arm retaining nut to 180 lb.ft.

**NOTE:** THIS PITMAN ARM TO STEERING GEAR FASTENER IS AN IMPORTANT ATTACHING PART IN THAT IT COULD AFFECT THE PERFORMANCE OF VITAL COMPONENTS AND SYSTEMS, AND/OR COULD RESULT IN MAJOR REPAIR EXPENSE. IT MUST BE REPLACED WITH ONE OF THE SAME PART NUMBER OR WITH AN EQUIVALENT PART IF REPLACEMENT BECOMES NECESSARY. DO NOT USE A REPLACEMENT PART OF LESSER QUALITY OR SUBSTITUTE DESIGN. TORQUE VALUES MUST BE USED AS SPECIFIED DURING REASSEMBLY TO ASSURE PROPER RETENTION OF THIS PART.

## DIVISION IV

### REMOVAL AND INSTALLATION

#### 90-13 REMOVAL AND INSTALLATION OF POWER STEERING GEAR

##### a. Removal

1. Place fender cover over left front fender.

2. Disconnect the pressure and return line hoses at the steering gear and elevate ends of hoses higher than pump to prevent oil from draining out of pump.

3. Remove pinch bolt securing lower steering column flexible coupling flange to steering gear stub shaft.

4. Remove pitman arm nut, then remove the pitman arm using puller J-5504. See Figure 90-33.

5. Loosen the three frame to steering gear bolts at outside of frame and remove steering gear.

##### b. Installation

**NOTE:** Fasteners in step 1 are important attaching parts in that they could affect the performance of vital components and systems, and/or could result in major repair expense. They must be replaced with one of the same part number or with an equivalent part if replacement becomes necessary. Do not use a replacement part or lesser quality or substitute design. Torque values must be used as specified during reassembly to assure proper retention of these parts.

1. Install the gear assembly by reversing the procedure for removal. See Figure 90-72 for tightening specifications. Torque pitman nut 180 lb. ft. Torque flexible coupling pinch bolt to 30 lb.ft. Be sure there is 3/64" clearance between adjuster plug and gear coupling flange.

**NOTE:** Power steering hoses should be installed to maintain a minimum clearance of 1" between hoses and 1/2" to surrounding parts.

2. Fill pump reservoir to correct level with Buick Power Steering oil or equivalent.

3. Start engine and maintain oil level in reservoir while allowing engine to idle for at least three minutes before turning steering wheel. Then rotate steering wheel through its entire range slowly a few times with engine running. Re-check oil level and inspect for possible leaks.

**NOTE:** If air becomes trapped in the oil, the oil pump may be noisy until all air is out of oil. This may take some time since air trapped in oil does not bleed out rapidly.

#### 90-14 REMOVAL AND INSTALLATION OF POWER STEERING OIL PUMP

##### a. Removal

**NOTE:** It is not necessary to remove oil pump to service the flow control valve. The flow control valve is retained in pump housing by a pressure union and filter assembly. See Figure 90-37.

1. Remove pump drive belt tension adjusting bolt. Disconnect belt from pump.

2. Disconnect return and pressure hoses from pump. Cover the hose connector and union on pump and open ends of the hoses to avoid entrance of dirt.
3. On 43-44000 Series cars remove 2 nuts securing rear of pump to bracket, and 2 bolts securing front of pump to bracket and remove pump.
4. On 45-46-48-49000 Series cars remove 1 nut securing rear of pump to rear adapter and 2 bolts securing front of pump to front adapter and remove pump.

**b. Installation**

1. Install the oil pump by reversing the procedure for removal.
2. When pump is reinstalled on engine adjust drive belt tension to 90 pounds.

**CAUTION:** Do not pry against the sheet metal reservoir or use a bar in the neck of the reservoir, or serious leak problems may result. There is a pry tab built into the brackets adjusting belt tension.

3. Fill pump reservoir to correct level with Buick Power Steering oil or equivalent.
4. Start engine and maintain oil level in reservoir while allowing engine to idle for at least three minutes before turning steering wheel. Then rotate steering wheel through its entire range slowly a few times with engine running. Recheck oil level and inspect for possible leaks.

**NOTE:** If air becomes trapped in the oil, the oil pump may be noisy until all air is out of oil. This may take some time since air trapped in oil does not bleed out rapidly.

**90-15 REMOVAL AND INSTALLATION OF OIL PUMP SHAFT SEAL WITH PUMP ASSEMBLED**

**a. Removal**

1. Remove pump pulley nut.
2. Remove pump drive belt from pulley.
3. Remove pulley from pump using a suitable puller. Do not hammer pulley off shaft.
4. Remove pulley drive key from shaft.

**NOTE:** On upper series equipped with air conditioner it is necessary to remove pump from its mounting due to interference with fan shroud.

5. Insert a piece of .005" shim stock (approximately 2-1/2" long) around shaft and push it past seal until it bottoms in pump housing. See Figure 90-34.

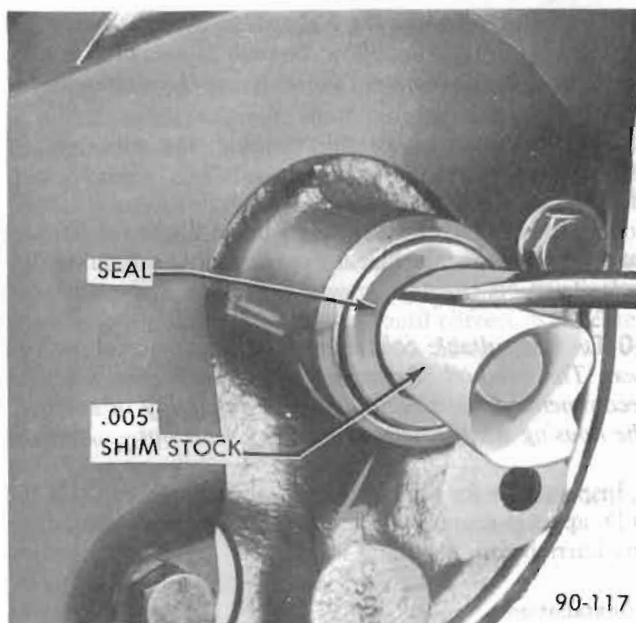

Figure 90-34 Removing Oil Pump Shaft Seal

6. Remove seal by cutting metal body of seal with a sharp tool and prying out. See Figure 90-34. *Extreme care must be used to prevent damage to shaft and pump housing.*

**b. Installation**

1. Place seal protector J-7586 over shaft. Lubricate new seal with power steering oil and drive in pump housing, spring side first, with installer J-7728. See Figure 90-35. Just bottom seal in housing. *Excessive force must not be used when driving seal in place.*



Figure 90-35 Installing Oil Pump Shaft Seal

2. Install pulley drive key in shaft.

3. Install pulley and drive belt. Adjust belt tension to 90 pounds.

4. Fill pump reservoir to proper level with power steering oil and bleed pump.

## DIVISION V

### OVERHAUL AND MAJOR SERVICE

#### 90-16 DISASSEMBLY, INSPECTION, AND REASSEMBLY OF ADJUSTER PLUG ASSEMBLY AND ROTARY VALVE ASSEMBLY

*THE FOLLOWING PROCEDURES ARE WITH THE POWER STEERING GEAR ASSEMBLY REMOVED.*

##### a. Removal of Adjuster Plug Assembly and Rotary Valve Assembly

1. Thoroughly clean exterior of gear assembly with a suitable solvent. Drain the unit by placing the valve ports down and turning the worm through its entire range two or three times.

2. Place gear assembly in vise.

3. Loosen adjuster plug lock nut with punch and remove adjuster plug using adjustable spanner wrench, J-7624.

4. Remove rotary valve assembly from gear by grasping stub shaft and pulling out.

**NOTE:** *If it is only necessary to service the rotary valve assembly, proceed with subparagraph "d".*

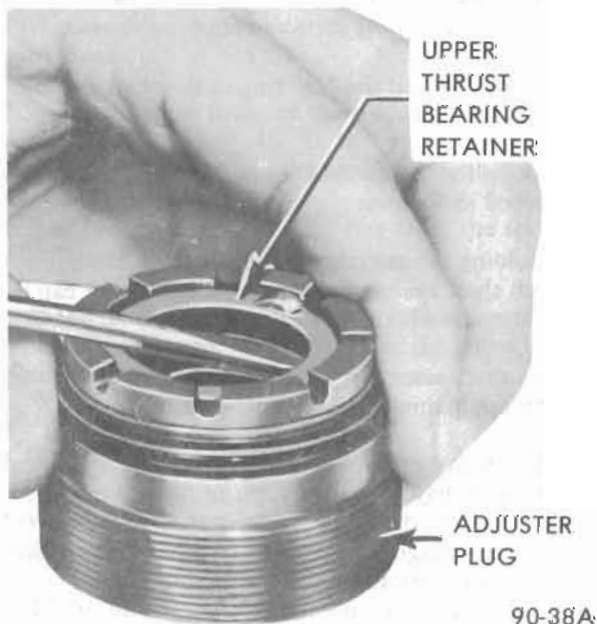

90-38A

Figure 90-39 Removing Upper Thrust Bearing Retainer

##### b. Disassembly of Adjuster Plug Assembly

1. Remove the upper thrust bearing retainer with a screwdriver, being careful not to damage the needle bearing bore. See Figure 90-39. Discard retainer. Remove thrust bearing spacer, upper thrust bearing and thrust bearing races.

2. Remove adjuster plug "O" ring and discard.

3. Remove stub shaft seal retaining ring using No. 3 truarc pliers J-4245 and remove and discard dust seal. See Figure 90-40.

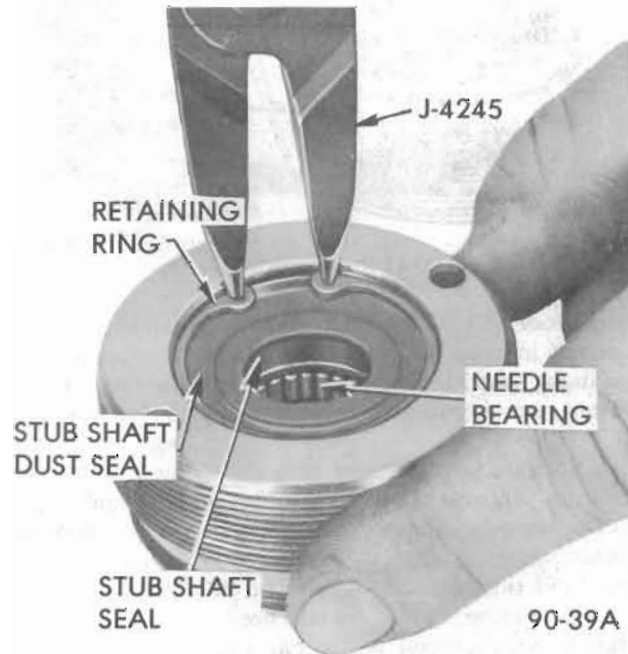

90-39A

Figure 90-40 Removing Stub Shaft Seal Retaining Ring

4. Remove stub shaft seal by prying out with screwdriver and discard.

5. Inspect needle bearing in adjuster plug and if rollers are broken or pitted, remove needle bearing by pressing from thrust bearing end using tool J-6221 and discard bearing. See Figure 90-41.

6. Inspect thrust bearing spacer for cracks.

7. Inspect thrust bearing rollers and thrust bearing races for wear, pitting, scoring, cracking or brinelling. Replace any damaged parts.

##### c. Reassembly of Adjuster Plug Assembly

1. If needle bearing was removed because of damage, *install new needle bearing from thrust bearing end of adjuster plug, by pressing against identification end of bearing using tool J-6221.* End of bearing must be flush with bottom surface of stub shaft seal bore.

2. Lubricate new stub shaft seal with power steering oil and install seal with spring in seal toward adjuster plug

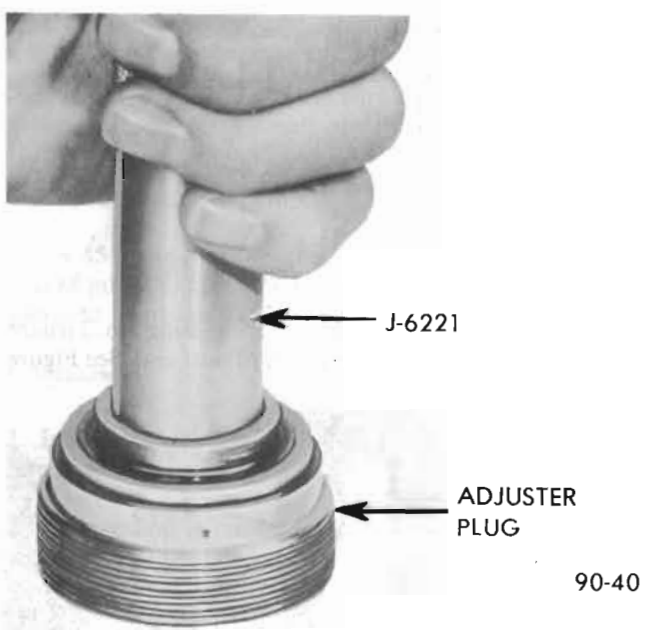

Figure 90-41 Removing Needle Bearing

using tool J-5188. See Figure 90-42. Install seal only far enough in plug to provide clearance for dust seal and retaining ring. Place new dust seal with lip up in plug, then install retaining ring with No. 3 Truarc pliers, J-4245.

3. Lubricate new adjuster plug "O" ring seal with petroleum jelly and install on adjuster plug. Assemble large O.D. thrust bearing race with internal flange up on adjuster plug, then thrust bearing, smaller thrust bearing race and thrust bearing spacer on adjuster plug. Install new thrust bearing retainer into needle bearing bore using punch, being careful not to damage spacer. See Figure 90-43. Radial location of dimples on retainer is not important. Thrust bearing assembly and spacer must be free to

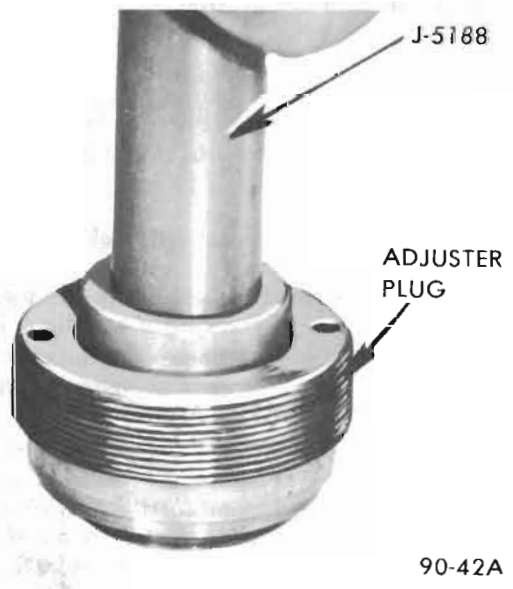

Figure 90-42 Installing Stub Shaft Seal

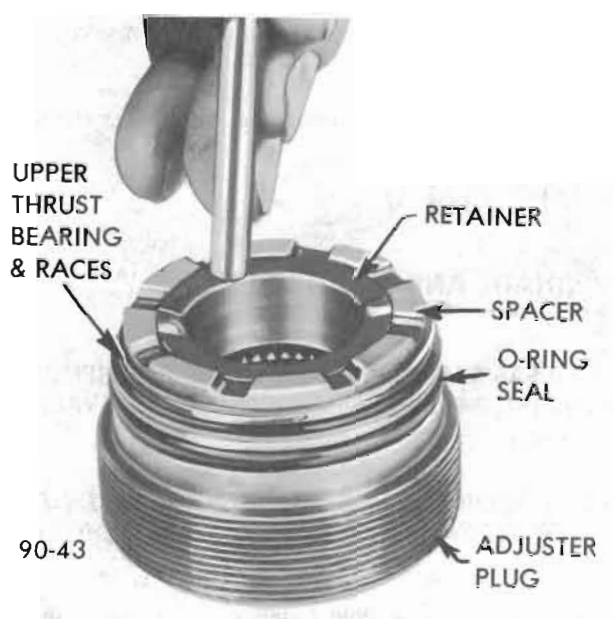

Figure 90-43 Installing Upper Thrust Bearing Retainer

rotate and retainer must be completely bezowsurface of spacer.

**d. Disassembly of Rotary Valve Assembly**

*It is very uncommon to have to make any service repairs to the valve assembly with the possible exception of the valve spool dampener "O" ring seal. DO NOT disassemble the valve unless absolutely necessary since this may result in damage to the assembly. If the valve spool dampener "O" ring seal requires replacement, remove the valve spool only, replace the "O" ring and reinstall the spool immediately. DO NOT disassemble further.*

**CAUTION:** Cleanliness of parts and work area is of the utmost importance during servicing of the valve assembly.

1. Remove and discard the "O" ring in the shaft cap end of the valve assembly.
  2. To remove the lower shaft assembly from the valve body, proceed as follows:
    - a. While holding the assembly (lower shaft down), lightly tap the stub shaft against the bench until the shaft cap is free from the valve body. See Figure 90-44.
    - b. Pull the shaft assembly until the shaft cap clears the valve body approximately 1/4".
- CAUTION:** Do not pull the shaft assembly out too far or the spool valve may become cocked in the valve body.
- c. Carefully disengage the shaft pin from the valve spool and remove the shaft assembly. See Figure 90-44.
3. Push the spool valve out of the flush end of the valve body until the dampener "O" ring is exposed, then care-

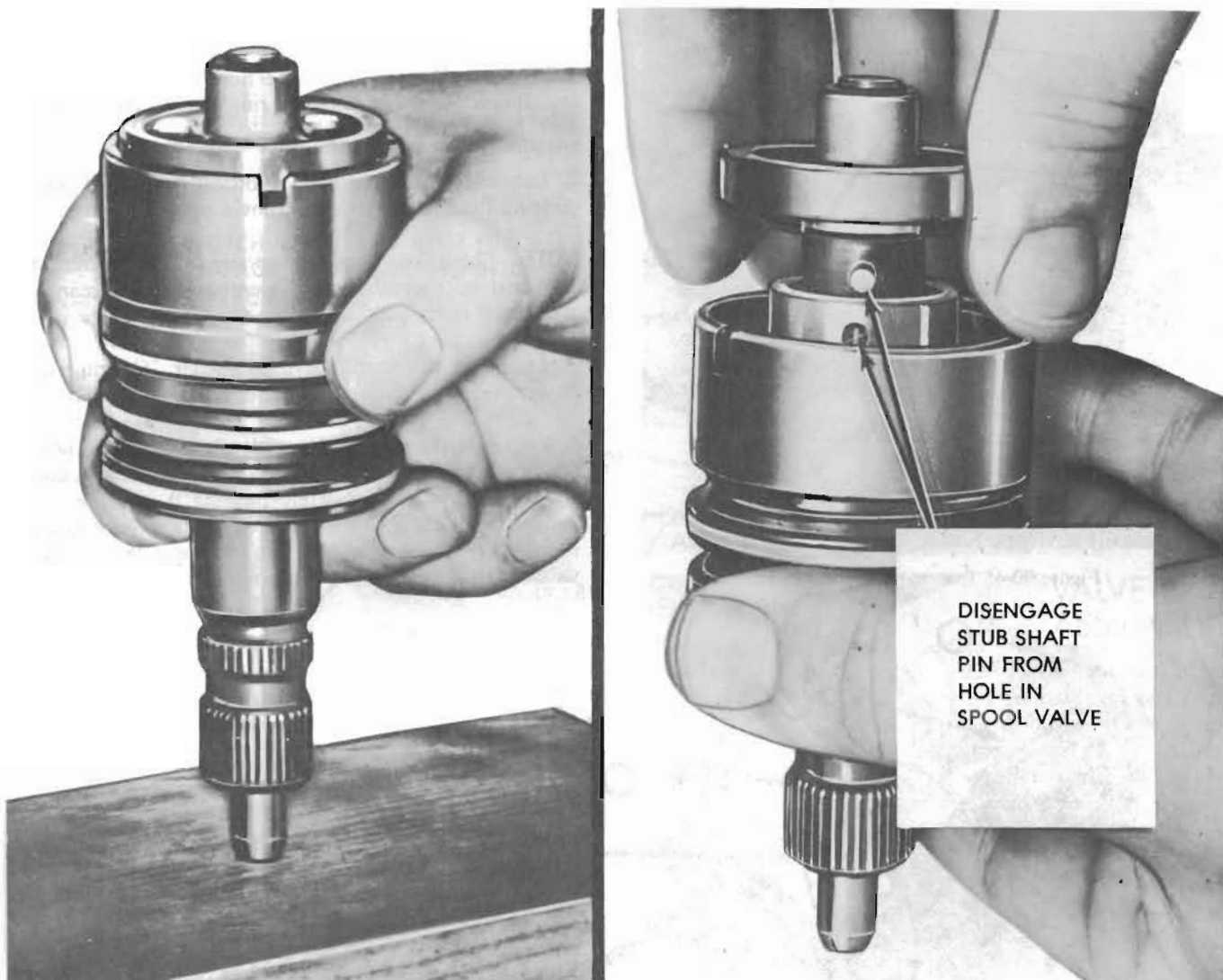

90-44A

Figure 90-44 Removing Stub Shaft Assembly

fully pull the spool from the valve body, while rotating the valve. See Figure 90-45. If the spool valve becomes cocked, carefully realign the spool valve, then remove.

4. Remove the dampener "O" ring from the spool valve and discard.

5. If the teflon oil rings are to be replaced, cut the three teflon oil rings and "O" rings from the valve body and discard.

#### e. Cleaning and Inspection

1. Wash all parts in clean solvent and blow out all oil holes with compressed air.

2. If the drive pin in the lower shaft or valve body is cracked, excessively worn, or broken, replace the complete valve and shaft assembly.

3. If there is evidence of leakage between the torsion bar and the stub shaft or scores, nicks, or burrs on the ground surface of the stub shaft that cannot be cleaned up with crocus cloth, the entire valve and shaft assembly must be replaced.

4. Check the outside diameter of the spool valve and the inside diameter of the valve body for nicks, burrs, or bad wear spots. If the irregularities cannot be cleaned up by the use of crocus cloth, the complete valve and shaft assembly will have to be replaced.

5. If the small notch in the skirt of the valve body is excessively worn, the complete valve and shaft assembly will have to be replaced.

6. Lubricate the spool valve with power steering fluid and check the fit of the spool valve in the valve body (with the spool valve dampener "O" ring removed). If the valve does not rotate freely without binding, the complete valve and shaft assembly will have to be replaced.



Figure 90-45 Removing Spool Valve

## f. Reassembly of Rotary Valve Assembly

1. If valve body "O" rings and teflon rings were removed, install new "O" rings in the oil ring grooves and lubricate with power steering fluid.

2. Lubricate the three new teflon oil rings with power steering fluid and install in grooves over "O" rings.

**NOTE:** *The teflon rings may appear to be distorted, but the heat of the oil during operation of the gear will straighten them out.*

3. Lubricate the spool valve dampener "O" ring with power steering fluid and install over the spool valve.

4. Lubricate the spool valve and valve body with power steering fluid and slide the spool valve into the valve body. Rotate the spool valve while pushing it into the valve body. Push the spool valve on through the valve body until the shaft pin hole is visible from the opposite end (spool valve flush with shaft cap end of valve body).

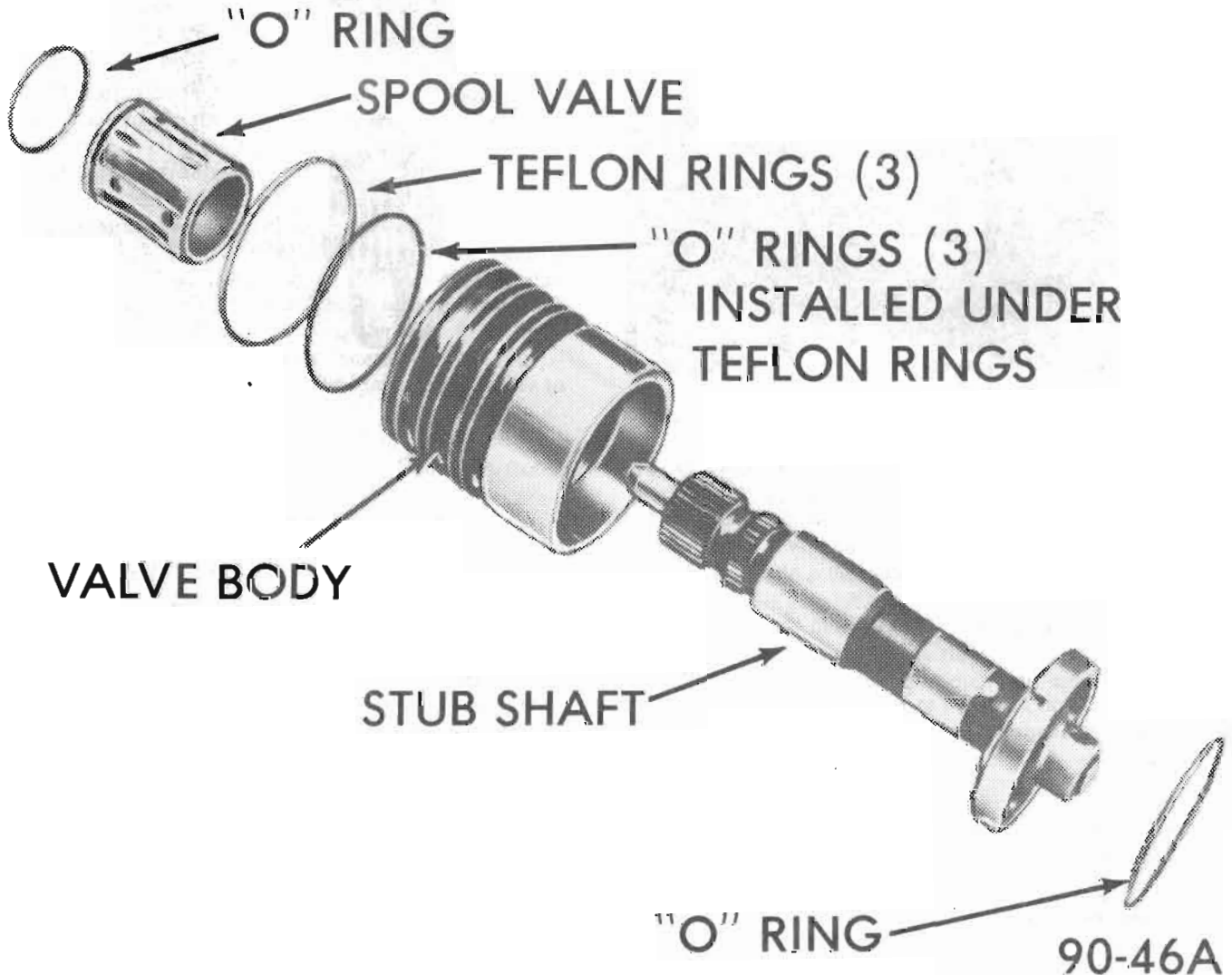

Figure 90-46 Exploded View - Valve Body and Shaft Assembly



5. Lubricate the shaft assembly with power steering fluid and carefully install it into the spool valve until the shaft pin can be placed into the hole in the spool valve.

6. Align the notch in the shaft cap with the pin in the valve body and press the spool valve and shaft assembly into the valve body. See Figure 90-47.

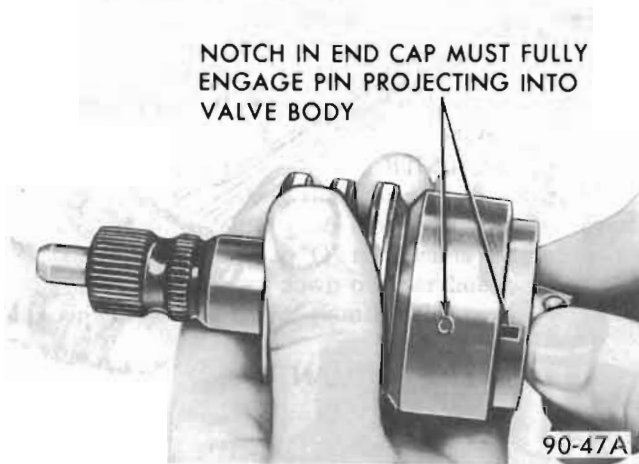

Figure 90-47 Installing Stub Shaft Assembly

**CAUTION:** Make sure that the shaft cap notch is mated with the valve body pin before installing valve body into the gear assembly.

7. Lubricate a new "O" ring with power steering fluid and install it in the shaft cap end of the valve body assembly.

#### g. Installation of Rotary Valve Assembly and Adjuster Plug Assembly

1. Align the narrow pin slot on the valve body with the valve body drive pin on the worm. Insert the valve assembly into the gear housing by pressing against the valve body with the finger tips. Do not press on stub shaft or torsion bar. See Figure 90-50. The return hole in the gear housing should be fully visible when valve is assembled properly. See Figure 90-51.

**CAUTION:** Do not push against the stub shaft during assembly as this may cause the stub shaft and cap to pull out of the valve body, allowing the spool dampener "O" ring seal to slip into valve body oil grooves. Be sure valve is properly seated before installing adjuster plug assembly.

2. Place seal protector J-6222 over end of stub shaft. Install adjuster plug assembly in gear housing snugly with adjustable spanner wrench J-7624 then back plug off approximately 1/8 turn. Install adjuster plug lock nut if removed, but do not tighten.

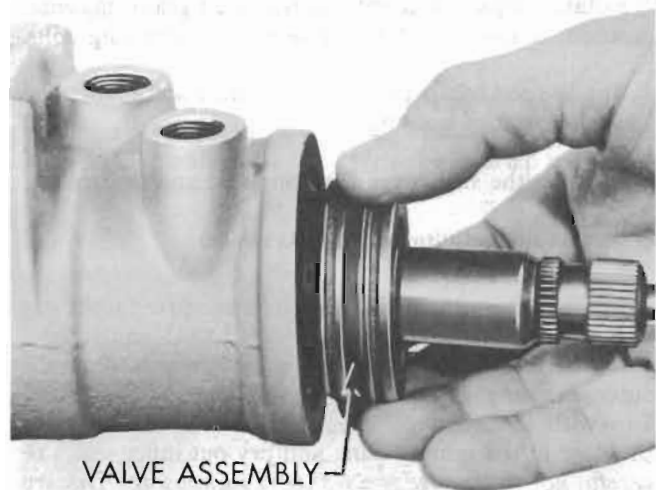

90-50

Figure 90-50 Inserting Valve Assembly in Housing

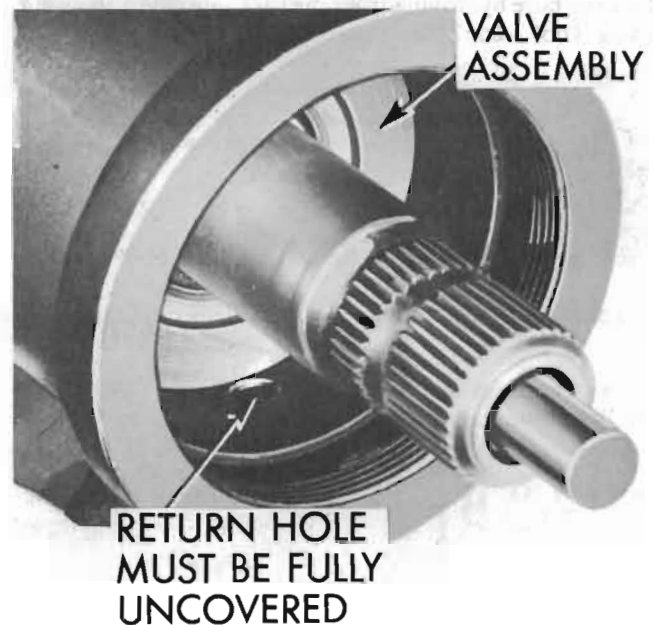

Figure 90-51 Valve Assembly Installed in Housing

3. Refer to paragraph 90-11 for adjustment of gear assembly.

### 90-17 DISASSEMBLY, INSPECTION AND REASSEMBLY OF PITMAN SHAFT ASSEMBLY

#### a. Removal of Pitman Shaft Assembly

1. Thoroughly clean exterior of gear assembly with a suitable solvent. Drain the unit by placing the valve ports down and turning the worm through its entire range two or three times.

2. Place gear assembly in vise.

3. Rotate the stub shaft until pitman shaft gear is in center position. Remove the housing side cover retaining bolts.
4. Tap the end of the pitman shaft with a soft mallet and slide shaft out of housing.
5. Remove the side cover "O" ring seal and discard.

**b. Disassembly of Pitman Shaft Assembly**

1. Remove the pitman shaft seal retaining ring from end of housing using No. 3 truarc pliers J-4245 and remove outer seal back-up washer. Tap a screwdriver between the outer seal and the inner back-up washer and pry out seal. Tap with screwdriver between the inner seal and the shoulder in the gear housing and pry out inner seal. *Be careful not to damage the seal bore in housing.* Discard seals.

2. Check the pitman shaft needle bearing for wear, pitting, or scoring. If damaged, remove needle bearing from gear housing bore by driving from the seal bore side of housing using Tool J-6657. See Figure 90-52. Discard bearing.

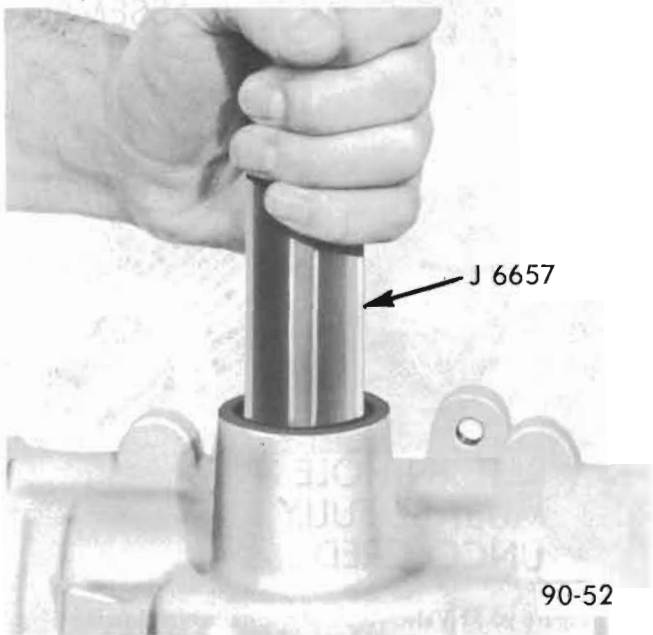

Figure 90-52 Removing Pitman Shaft Needle Bearing

3. Hold the lash adjuster with an Allen wrench and remove the lash adjuster nut. Discard nut. Remove side cover from lash adjuster.

**c. Inspection of Pitman Shaft Assembly**

1. Inspect pitman shaft bushing surface in side cover for excessive wear or scoring. If worn or scored, replace side cover.
2. Check the pitman shaft sector teeth and the bearing and seal surfaces. If worn, pitted or scored replace pitman shaft.

3. Check the torque on the lash adjuster. See Figure 90-53. If torque exceeds 15 lb. in., pitman shaft assembly should be replaced.

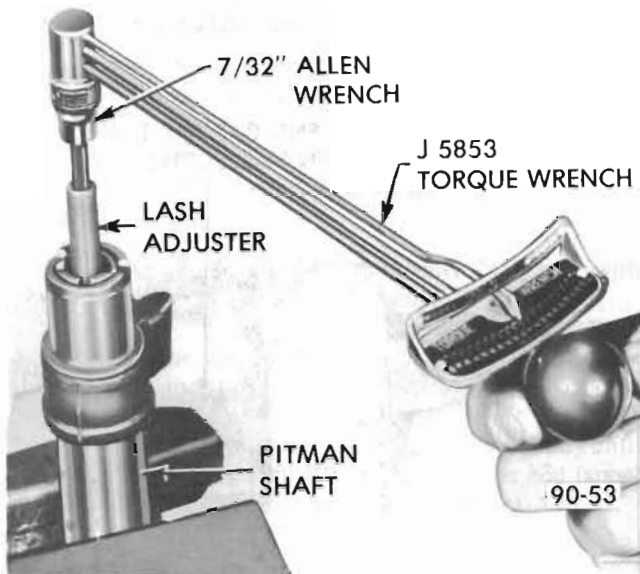

Figure 90-53 Checking Torque on Lash Adjuster

**d. Reassembly of Pitman Shaft Assembly**

1. If pitman shaft needle bearing was removed because of damage, install new needle bearing into gear housing bore from seal bore end, pressing against stamped identification on bearing with tool J-6657. Press in until bearing clears shoulder in gear housing, 1/32" maximum. Rollers in bearing must be free to rotate.

2. Lubricate new pitman shaft seals with power steering oil. Install the inner, single lip seal in bore first, then a back-up washer. See Figure 90-54. Using tool J-6219, drive the seal and washer in far enough to provide clearance for the outer seal, back-up washer and retaining ring. See Figure 90-55. *The inner seal must not bottom on the counterbore.* Install the outer double lip seal and the second back-up washer in bore only far enough to provide clearance for the retaining ring with tool J-6219. Install retaining ring with No. 3 Truarc pliers tool J-4245, making certain that ring is seated properly.

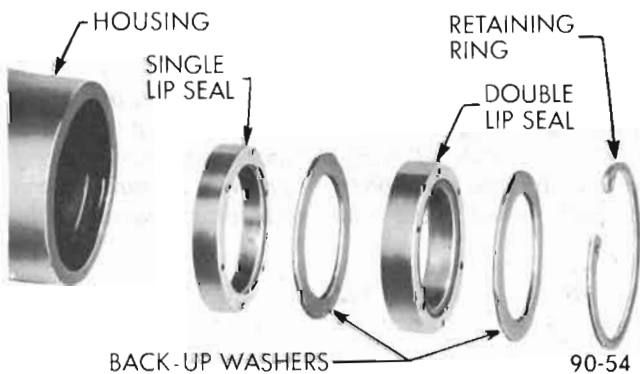

Figure 90-54 Pitman Shaft Seals

3. Assemble the side cover on the pitman shaft. Screw the lash adjuster through the side cover until the side cover bottoms on the shaft and then back off 1/2 turn.

#### e. Installation of Pitman Shaft Assembly

1. Lubricate a new side cover "O" ring seal with power steering oil and install in groove in face of side cover.

2. Turn the stub shaft until the center groove of the rack-piston is aligned with the center of the pitman shaft hole.

3. Wrap masking tape over the end of pitman shaft. Install the pitman shaft so that the center tooth in the sector meshes with the center groove of the rack-piston nut. Make sure the side cover "O" ring seal is in place before pushing the side cover down on gear housing. Remove masking tape from end of pitman shaft.



Figure 90-55 Installing Pitman Shaft Seals

4. Install the four side cover bolts with lock washers and tighten to 30 lb. ft.

5. Install new lash adjuster nut on lash adjuster, but do not tighten.

6. Refer to paragraph 90-11 for adjustment of gear assembly.

#### 90-18 DISASSEMBLY, INSPECTION AND REASSEMBLY OF RACK-PISTON NUT AND WORM ASSEMBLY

##### a. Removal of Rack-Piston Nut and Worm Assembly

1. Thoroughly clean exterior of gear assembly with a suitable solvent. Drain the unit by placing the valve ports down and turning the worm through its entire range two or three times.

2. Remove pitman shaft assembly as outlined in paragraph 90-17 (a).

3. Rotate housing end plug retainer ring so that one end of ring is over hole in gear housing. Spring one end of ring with punch to allow screwdriver to be inserted to lift ring out. See Figure 90-56.

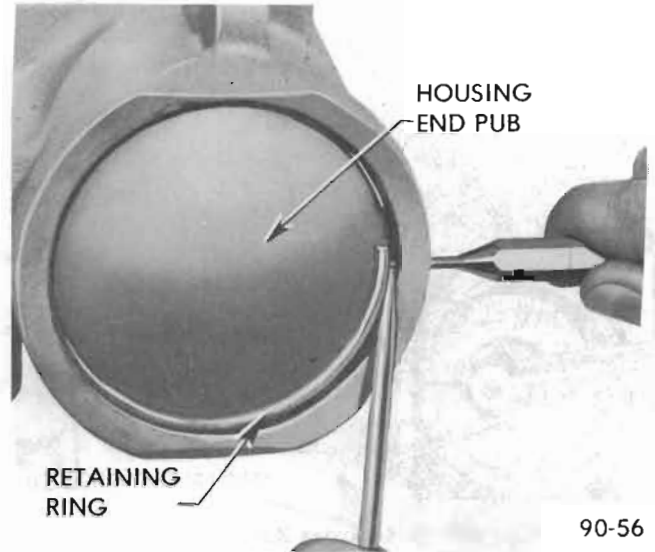

Figure 90-56 Removing Housing End Plug Retaining Ring

4. Rotate stub shaft to full left turn position to force end plug out of housing.

**CAUTION:** Do not rotate farther than necessary or the balls from the rack-piston and worm assembly will fall out.

5. Remove and discard housing end plug "O" ring seal.

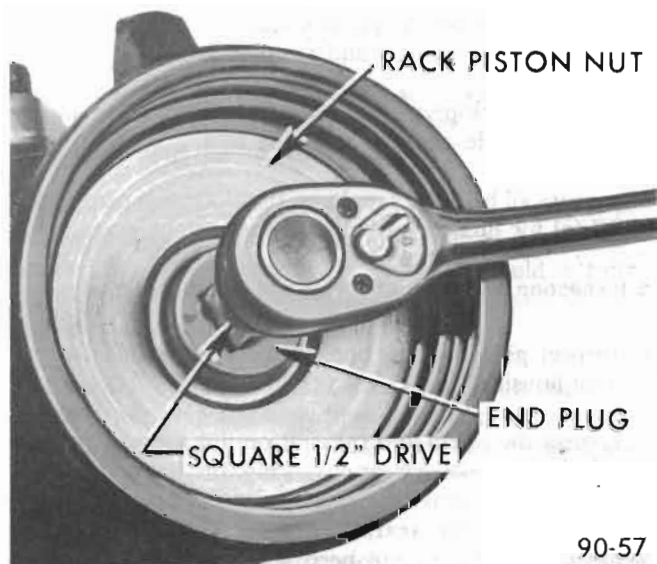

Figure 90-57 Removing Rack-Piston Nut End Plug

6. Remove rack-piston nut end plug with a 1/2" square drive. See Figure 90-57.

7. Insert ball retaining tool J-7539 in end of worm. See Figure 90-58. Turn stub shaft so that rack-piston nut will go onto the tool and remove rack-piston nut from gear housing. Keep ball retaining tool completely through rack-piston nut to prevent balls from falling out.

**NOTE:** On 45-46-48-49000 Series gears, do not remove snap ring in upper end of piston bore in housing.

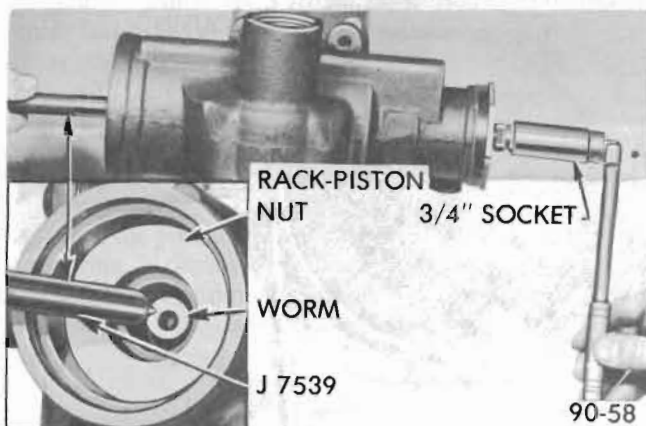

Figure 90-58 Removing Rack-Piston Nut

8. Remove adjuster plug assembly and rotary valve assembly as outlined in paragraph 90-16 (a).

9. Remove worm and lower thrust bearing and races.

10. Remove cap to worm "O" ring seal and discard.

#### b. Disassembly of Rack-Piston Nut and Worm Assembly

1. Remove and discard piston ring and back-up "O" ring on rack-piston nut.

2. Remove ball return guide clamp to rack-piston nut screws and lock washers and remove clamp.

3. Place the rack-piston nut on a clean cloth and remove ball return guide and ball retaining tool.

Make sure all balls are caught on the cloth. See paragraph 90-20 (c) for number of balls for the various gears.

#### c. Inspection of Rack-Piston Nut and Worm Assembly

1. Inspect gear housing bore. If badly scored or worn, replace housing.

2. Inspect the worm and rack-piston nut grooves and all the balls for excessive wear or scoring. Inspect rack-piston nut teeth for pitting, wear or scoring. Inspect O.D. of rack-piston nut for wear, scoring or burrs. If either the worm or rack-piston nut need replacing, both must be replaced as a matched assembly.

3. Inspect ball return guides, making sure that the ends where the balls enter and leave the guides are not damaged. Replace if necessary.

4. Inspect lower thrust bearing and races for wear, pitting, scoring or cracking. Replace any damaged parts.

5. Inspect the hose connectors in the gear housing. If badly brinelled or scored, replacement will be necessary. To remove the connectors, tap threads using 5/16-18 tap. Thread a bolt with a nut and flat washer into the tapped hole. Pull the connector by holding the bolt and turning the nut off the bolt. Wash and blow the housing out thoroughly to remove any tapping chips. To install new connector, use replacer J-6217 to drive connector in place.

6. Check the operation of check valve poppet located under connector in pressure port of housing. Poppet should reseat itself against connector after being lightly pushed down. If poppet is not operating properly, remove connector, poppet and spring from pressure port. Then install a new spring with large end down and a new poppet with tangs pointed down. Install a new connector using installer J-6217. Be sure new poppet operates properly.

7. Inspect the ball plug in gear housing. If it is leaking or raised above the housing surface, it may be driven in flush to 1/16 inch below surface. The ball can be tightened by staking the housing. If the leakage cannot be stopped, the housing should be replaced.

#### d. Reassembly of Rack-Piston Nut and Worm Assembly

1. Thoroughly clean and lubricate the internal parts with power steering oil.

2. Install new piston ring back-up "O" ring in groove on



Figure 90-59 Installing Rack-Piston Ring on Rack-Piston Nut

rack-piston nut. Place a new piston ring over the back-up "O" ring. See Figure 90-59.

3. Install worm into rack-piston nut to bearing shoulder.
4. Align the ball return guide holes in the rack piston nut with the worm groove. Load all balls, except 6 (3 plain and 3 black) in alternate sequence into the guide hole nearest the piston ring while slowly rotating worm counterclockwise. See Figure 90-60.

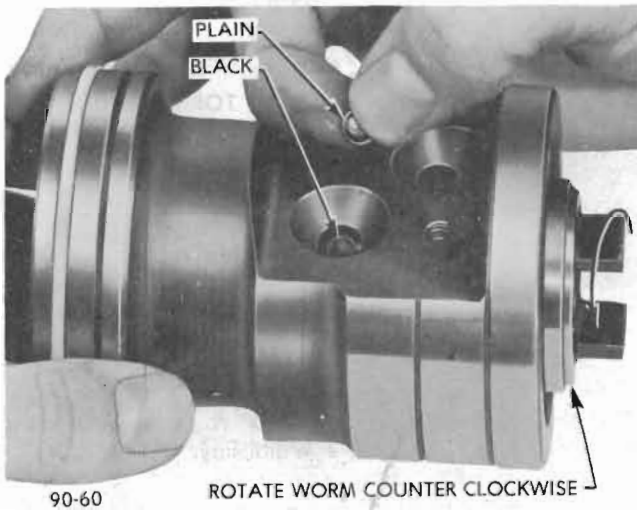

Figure 90-60 Loading Balls in Rack-Piston Nut

5. Fill one-half the ball return guide with the remaining 6 balls, 3 plain and 3 black balls in alternate sequence. Place the other half of guide over the balls and plug each end with heavy grease to prevent the balls from falling out when installing the guide to the rack-piston nut.
6. Insert ball return guide into guide holes in the rack-piston nut so that balls in the guide alternate with the balls in the rack-piston nut. Guide should fit loosely.
7. Place clamp over guide and install 2 screws with special lock washers and tighten.
8. The worm groove is ground with a high point in the center. When the rack-piston nut passes over this high point, a preload of 1 to 5 pound inch should be obtained. To measure the preload of the assembly, lightly clamp rack-piston nut in a soft jaw vise with worm pointing up. Do not distort rack-piston nut by tightening too heavily. Place valve assembly on worm, engaging worm drive pin. Rotate the worm until it extends 1-1/4 inches from the edge of rack-piston nut to the thrust bearing face of worm; this is the center position. Attach torque wrench J-5853 with 3/4 inch, 12 point socket to the stub shaft. See Figure 90-61. Rotate the wrench through a total arc of approximately 60 degrees (1/6 turn) in both directions several times and take a reading. The highest reading obtained with the worm rotating should be from 1 to 5 pound inch.

If the reading is too high, disassemble and reassemble, using the next size smaller plain balls and recheck. (A rack-piston nut with a ball size of 7 does not have a number stamped on the flat surface. For ball sizes other than 7, the ball size is stamped on the flat surface of the rack-piston nut.) If the reading is too small, use the next size larger plain balls and recheck. See paragraph 90-20, subparagraph b for ball size. Remove valve assembly from worm.

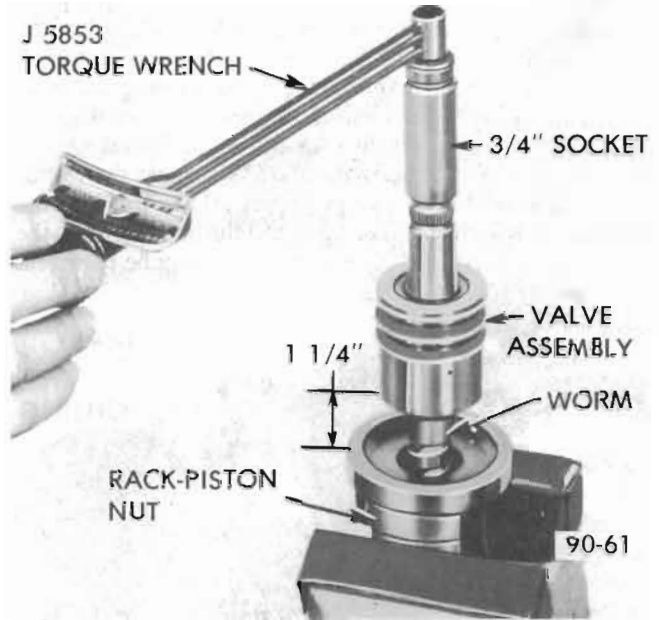

Figure 90-61 Checking Rack-Piston Nut Ball Preload

9. Turn the rack-piston nut and worm assembly to a horizontal position in the vise and insert ball retaining tool J-7539 in end of worm and turn worm out of the rack-piston nut. Do not allow the tool to separate from the worm until worm is fully removed from rack-piston nut.

#### e. Installation of Rack-Piston Nut and Worm Assembly

1. Assemble lower thrust bearing and races on worm. Install new cap to worm "O" ring seal. Assemble rotary valve assembly to worm by aligning narrow pin slot in valve body with pin on worm.
2. Insert the valve assembly and worm in gear housing as an integral unit. Do not press on stub shaft or torsion bar. See Figure 90-50. Return hole in housing should be fully visible when valve and worm are properly installed. See Figure 90-51.
3. Place seal protector J-6222 over end of stub shaft. Install adjuster plug assembly in gear housing snugly with adjustable spanner wrench J-7624 then back plug off approximately 1/8 turn. Install adjuster plug lock nut if removed, but do not tighten.
4. Adjust the thrust bearing preload. Using torque wrench J-5853, rotate stub shaft to measure valve assembly drag.

See Figure 90-31. Then tighten adjuster plug to obtain a reading 1 to 3 pound inch in excess of valve drag.

**NOTE:** Total of thrust bearing preload and valve drag should not exceed 11 pound inches.

5. Tighten adjuster plug lock nut. Recheck thrust bearing preload to be sure that tightening lock nut did not change adjustment.

6. Install ring compressor sleeve tool (J-8947 used for 43-44000 Series and 45000 Series with 350 engine; J-7576 used for 45-46-48-49000 Series) in gear housing and hold it tightly against shoulder in the housing. See Figures 90-62 and 90-63. Insert the rack-piston nut into the housing until the ball retaining tool J-7539 engages the worm. Turn the stub shaft drawing the rack-piston nut into the housing. When the piston ring is into the housing bore, the ball retaining tool and ring compressor may be removed.

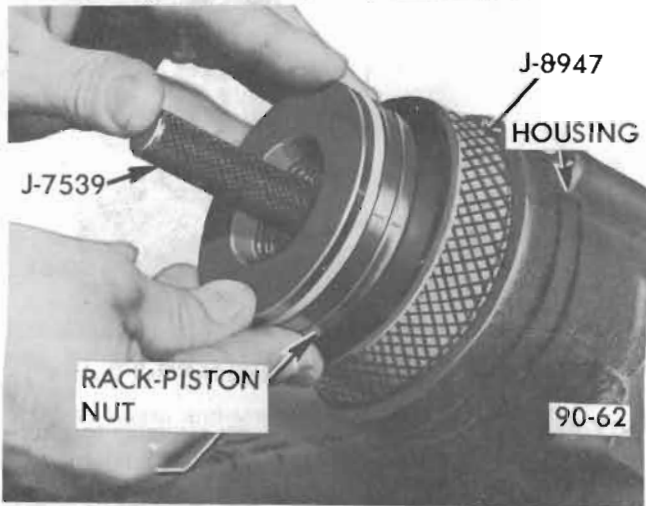

Figure 90-62 Installing Rack-Piston Nut - 43-44000 Series

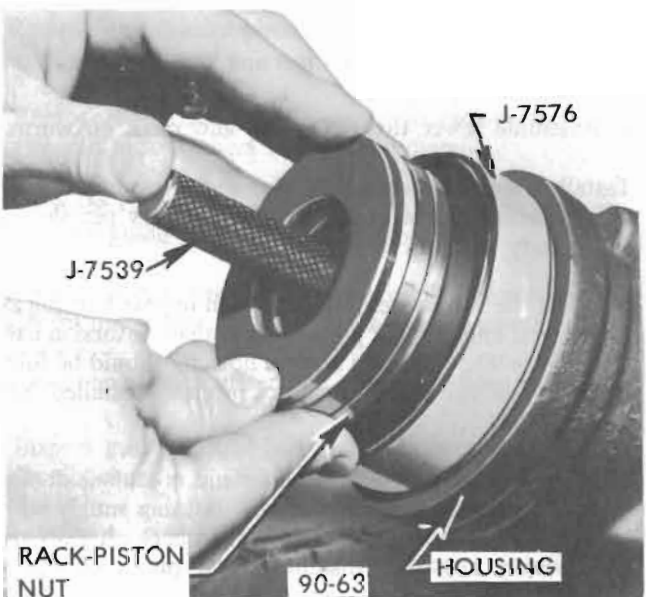

Figure 90-63 Installing Rack-Piston Nut - 45-46-48-49000 Series

7. Install rack-piston end plug using 1/2" square drive. Torque plug to 50 lb. ft. See Figure 90-64.

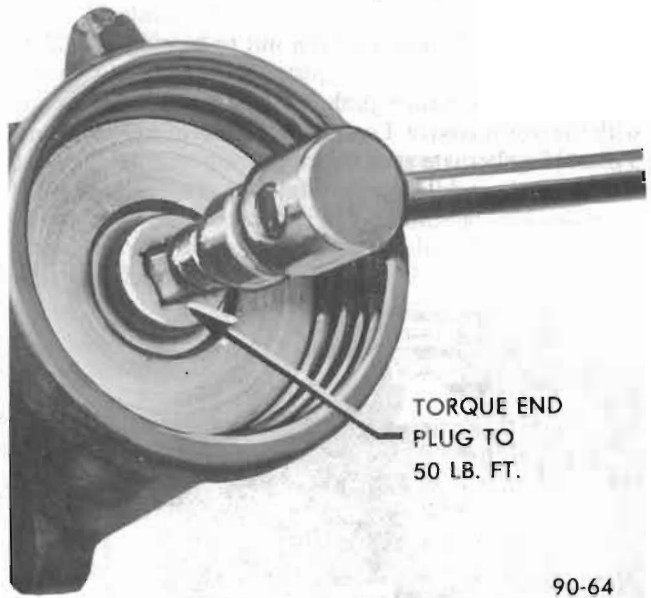

Figure 90-64 Torquing Rack-Piston Nut End Plug

8. Lubricate housing end plug "O" ring seal with power steering oil and install in gear housing.

9. Insert end plug into gear housing and seat against "O" ring seal. Slight tapping with a soft mallet may be necessary to seat plug properly. Install end plug retainer ring.

10. Install pitman shaft assembly as outlined in paragraph 90-17, subparagraph e, Steps 1 through 6.

### 90-19 DISASSEMBLY, INSPECTION AND REASSEMBLY OF OIL PUMP

**NOTE:** Refer to paragraph 90-14 for removal and installation of oil pump.

#### a. Disassembly of Oil Pump

1. Using masking tape, cover the hose union and pipe on pump and then thoroughly clean exterior of pump.
2. Remove pump pulley key from pump shaft.
3. Remove reservoir cap and drain out oil in pump reservoir.
4. Install pump in a soft jaw vise with pump shaft pointing down. Do not clamp pump too tightly in vise as this may distort bushing.
5. Remove two reservoir to pump housing studs and "O" rings. Discard the "O" rings.
6. Remove pressure union. Remove "O" ring from union and discard "O" ring.

7. Remove flow control valve and spring.
8. Remove reservoir from housing by rocking housing back and forth while pulling upward. Remove reservoir "O" ring seal on housing and discard. Remove small reservoir to housing "O" ring seal from counterbore in housing and discard.
9. Rotate end plate retaining ring until one end of ring is over hole in housing. Spring inward on one end of ring with 1/8" punch to allow screwdriver to be inserted and lift ring out. See Figure 90-65.

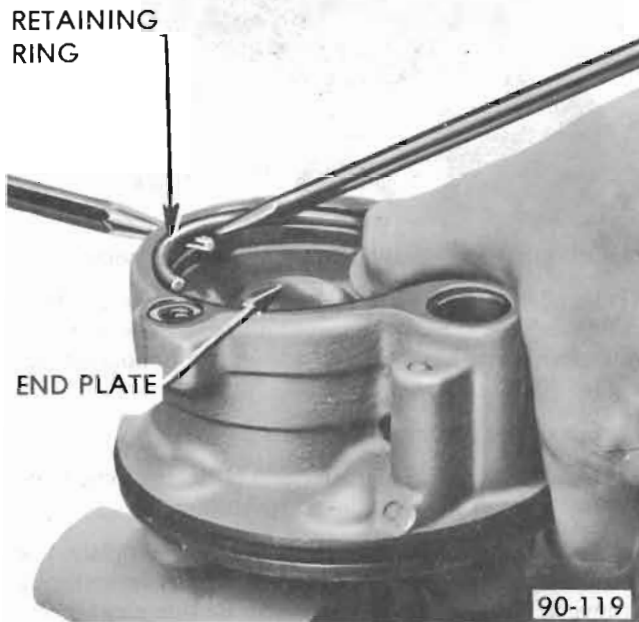

Figure 90-65 Removing End Plate Retaining Ring

10. Remove pump from vise and remove end plate, pressure plate spring, flow control valve and spring by turning pump over. If end plate should stick in housing, lightly tap it to align and free it.

**NOTE:** Do not disassemble control valve.

11. Remove and discard end plate "O" ring seal.
12. Place shaft end on bench and press down on housing until shaft is free. Turn housing over and remove shaft and rotor assembly, being careful not to drop parts. If the two dowel pins did not come out with assembly, remove dowel pins from housing.
13. If it is desired to disassemble the shaft and rotor assembly, use a screwdriver as shown in Figure 90-66.
14. Remove and discard pressure plate "O" ring seal.
15. Remove shaft seal, if defective, by prying out with small screwdriver.

#### b. Inspection of Oil Pump Parts:

Clean all parts thoroughly with solvent and wipe dry with clean, lint-free cloth before inspecting.

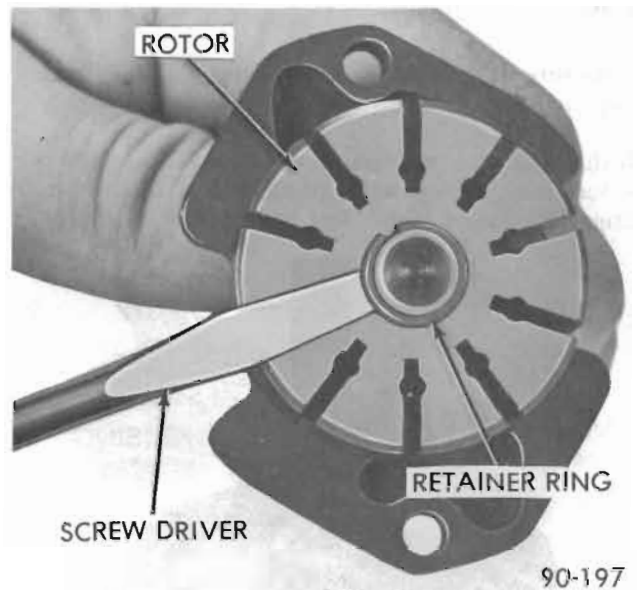

Figure 90-66 Removing Rotor Retaining Ring

1. Inspect shaft for wear.
2. Check fit of the ten vanes in slots of rotor; vanes must slide freely but fit snugly in slots. Tightness may be removed by thorough cleaning or removal of irregularities using a hard Arkansas stone. Replace rotor if excessive looseness exists between rotor and vanes. Replace vanes if they are irregularly worn or scored. Light scoring on the rotor can be repaired by carefully lapping surface of rotor.
3. Inspect all ground surfaces of the rotor ring for roughness or irregular wear. Slight irregularities may be removed with a hard Arkansas stone. Replace ring if inside cam surface is badly scored or worn and inspect outside radius of vanes very closely for damage.
4. Inspect the surfaces of the pressure plate and thrust plate for wear or scoring. Light scoring can be repaired by carefully lapping until surface is smooth and flat, after which all lapping compound must be thoroughly washed away.
5. Inspect the flow control valve bore in the housing for scoring, burrs or other damage. Hair line scratches are normal. Inspect bushing in housing, if worn or scored, replace housing.
6. Inspect the surfaces of the flow control valve for scores and burrs. Hair line scratches are normal. Replace valve if badly scored or if it is the cause of low pump pressure. Check the screw in the end of the valve, if loose, tighten being careful not to damage machined surfaces. Filter in end of screw must be clean.
7. Check orifice in pressure union to be sure it is not plugged.

### c. Reassembly of Oil Pump

1. Make sure all parts are absolutely clean. Lubricate seals and moving parts with power steering oil during assembly.
2. If shaft seal was removed, use installer J-7017 to drive new seal into housing with spring side of seal toward housing. See Figure 90-67. Just bottom seal in housing.

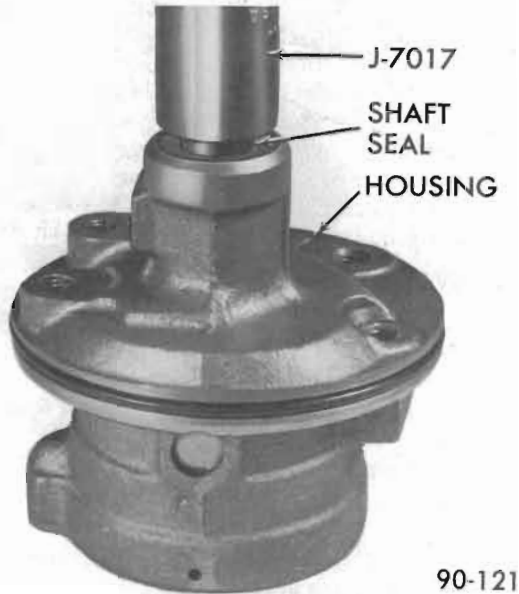

Figure 90-67 Installing Shaft Seal

3. Mount housing in vise with shaft end down. Install new pressure plate "O" ring seal in groove in housing bore. This seal is smaller than the end plate "O" ring seal and it has a daub of paint on it for identification.
4. Insert shaft into housing and press down with thumb on splined end to properly seat shaft. Be careful not to damage shaft seal in housing.
5. Install the two dowel pins in housing and install thrust plate on the pins with ported face of plate to rear of housing.
6. Install pump ring with small holes in ring on dowel pins and with arrow on outer edge to rear of housing.
7. Install rotor on pump shaft with spline side of rotor to rear of housing. Rotor must be free on shaft splines.
8. Install ten vanes in rotor slots with radius edge toward outside and flat edge toward center of rotor.
9. Install shaft retaining ring on pump shaft.
10. Lubricate the outside diameter and chamfer of pressure plate with petroleum jelly and install on dowel pins with ported face toward rotor. Dowel pins fit into slots in plate that are nearest outside diameter of plate. Use a soft plastic or wood rod and lightly tap around *outside diameter* of pressure plate to seat it. See Figure 90-68. Pressure

plate will travel about 1/16" to seat. *Never press or hammer on the center of pressure plate as this will cause permanent distortion and result in pump failure.*

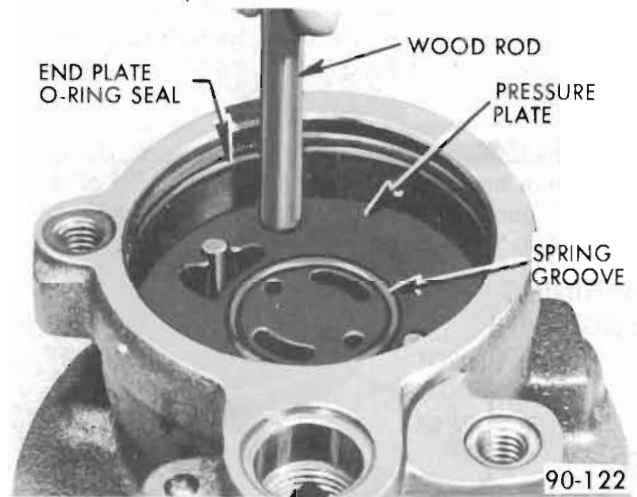

Figure 90-68 - Seating Pressure Plate in Housing

11. Install new end plate "O" ring seal in groove in bore of housing. Be sure not to install it in end plate retaining ring groove which is first groove from rear of housing. See Figure 90-68.
  12. Install the pressure plate spring.
  13. Lubricate outside diameter and chamfer of end plate with petroleum jelly and insert in housing.
  14. Place end plate retaining ring on top of end plate. Use an arbor press to lower end plate into housing until ring groove in housing is evenly exposed. Be sure ring is completely seated in housing groove and end plate is aligned properly.
- CAUTION:** *Press end plate into housing only far enough to install retaining ring in groove.*
15. Install new reservoir "O" ring seal on housing. Place pressure union seal and two stud seals in proper counterbores on rear of housing.
  16. Install reservoir on housing and line up holes for studs. Tap reservoir with a soft mallet to seat it on housing and install reservoir to housing studs with short end of stud in housing. Torque studs to 35 lb. ft.
  17. Install flow control valve spring in housing. Then install flow control valve with hex head of valve going in housing first. Check movement of valve.
  18. Assemble new "O" ring in groove nearest outlet end of pressure union. Install union in pump and torque 35 lb. ft.
- CAUTION:** *If "O" ring is installed in groove on pressure union that contains the flow orifice, pump will not build up pressure.*
19. Remove pump from vise and install shaft key on shaft. Support shaft on opposite side while installing key.
  20. Check for bind in pump by rotating drive shaft. Shaft must rotate freely by hand.



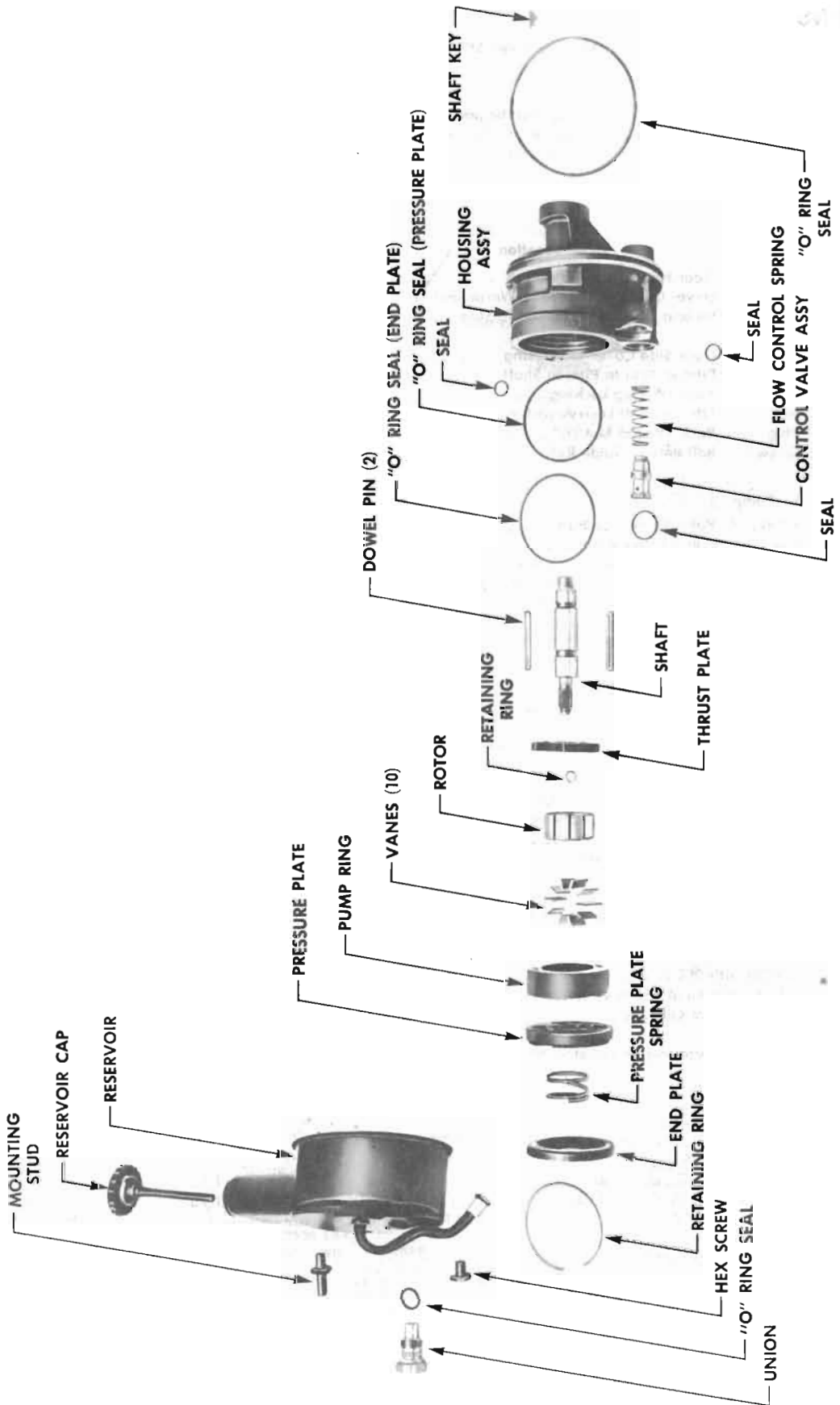

Figure 90-69 Oil Pump-Exploded View

# DIVISION VI

## SPECIFICATIONS

### 90-20 POWER STEERING GEAR AND PUMP SPECIFICATIONS

#### Tightening Specifications

Use a reliable torque wrench to tighten the parts listed to insure proper tightness without straining or distorting parts. These specifications are for clean and lightly lubricated threads only. Dry or dirty threads produce increased friction which prevents accurate measurements of tightness.

#### a. Gear

Part	Location	Thread Size	Torque Lb. Ft.
Bolt	Gear Housing to Frame	7/16-14	70
Bolt	Lower Coupling Flange to Worm Shaft	3/8-24	30
Nut	Steering Column Coupling to Steering Gear Shaft Flange	5/16-24	20
		3/8-24	20
Bolt	Gear Side Cover to Housing	3/8-16	30
Nut	Pitman Arm to Pitman Shaft	Special	180
Nut	Adjuster Plug Locking	Special	80
Nut	Pitman Shaft Lash Adjuster Locking	Special	23
Plug	Rack—Piston Nut End	Special	75
Screw	Ball Return Guide Retainer	1/4-28	10

#### b. Pump

Fitting	Pump Discharge Part	5/8-18	35
Nut	Pump Pulley Retaining	9/16-18	60
Nut	Pump to Mounting Bracket	3/8-16	35
Bolt	Pump Mounting Bracket to Engine	3/8-16	35
Fitting	Pressure Hose to Pump	5/8-18	25
Fitting	Pressure Hose to Gear	11/16-18	25
Fitting	Return Hose to Gear	5/8-18	25

90B-2

#### GENERAL SPECIFICATIONS

#### a. Gear

Gear Type	Recirculating Ball, Worm and Nut
Make	Saginaw
Gear Ratio Only	
43-44000	16.0 to 1
45000 with 350 Eng. and Estate Wagon	16.0 to 1
46-48-49000 and 45000 with 455 Eng.	15.0 to 1
Ratio Overall (Including Linkage)	
43-44000	18.7 to 1
45000 with 350 Eng. and Estate Wagon	17.9 to 1
46-48-49000 and 45000 with 455 Eng.	16.5 to 1
Turns of Steering Wheel, Stop to Stop	
43-44000	3.30
45000 with 350 Eng.	2.99
46-48-49000 and 45000 with 455 Eng.	2.94
Steering System Oil Type	Buick Power Steering Oil (Or Equivalent)
Number of Worm and Rack-Piston Nut Balls —	
All Series	12 Black 12 Plain

#### b. Pump

Pump Capacity, (Minimum) Gal./Min. at 465 RPM (Pump) X 665/735 P.S.I.	
250 and 350 Cu. In. Engine	1.25
455 Cu. In. Engine Less 43-44000	1.75
Pump Capacity (Maximum), Gal./Min. at 1500 RPM (Pump) X 50 P.S.I.	
250 Cu. In. Engine	3.10
350 and 455 Cu. In. Engines	2.80
Relief Valve Opening Pressure (P.S.I.)	
250 Cu. In. Engine	1350-1450
350 and 455 Cu. In. Engines	1250-1350
Pump Test Pressure, Min. P.S.I. at 525 R.P.M. (Engine) and 170 F. Oil Temperature	1000 Minimum

90B-3

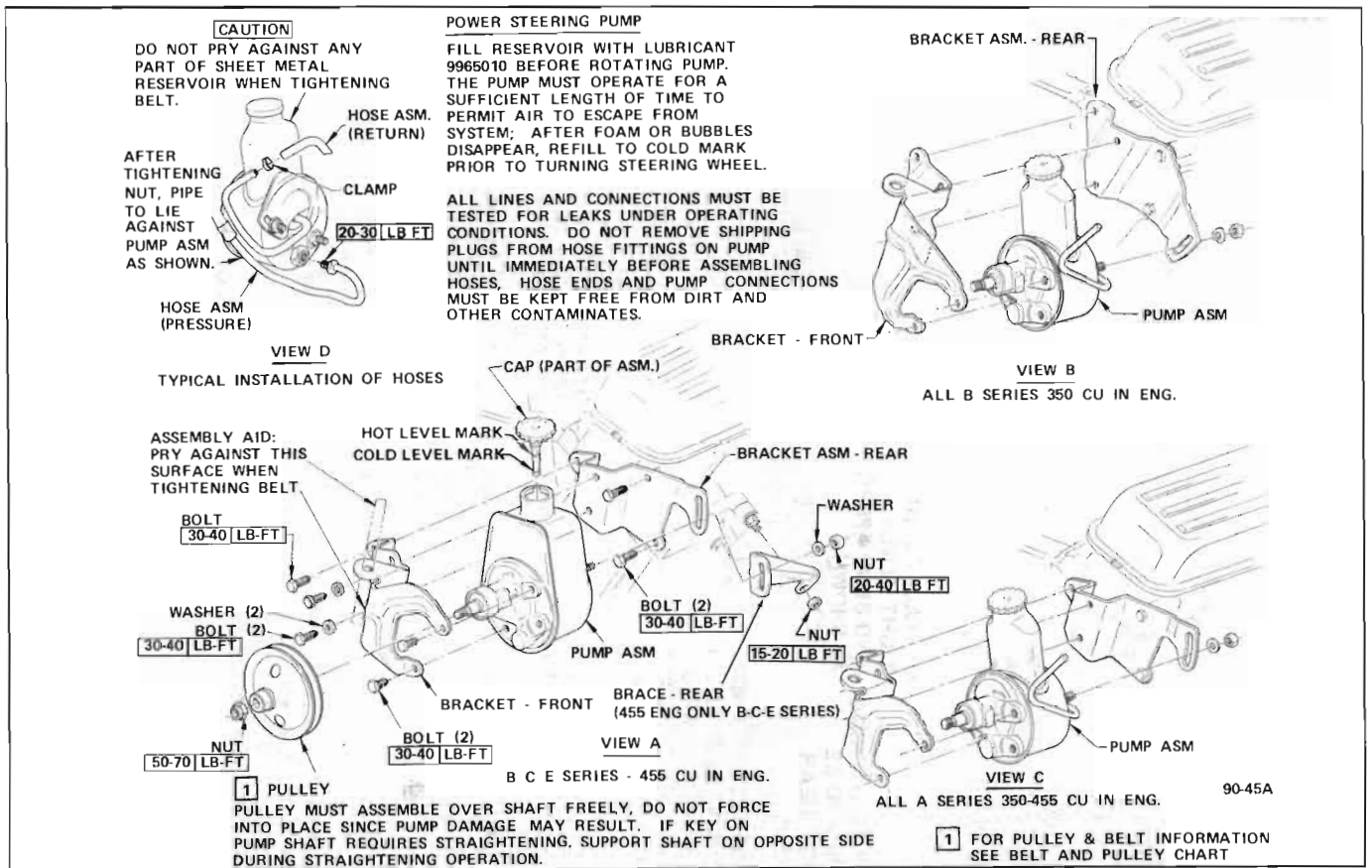

Figure 90-70 Power Steering Pump and Brackets - All Series

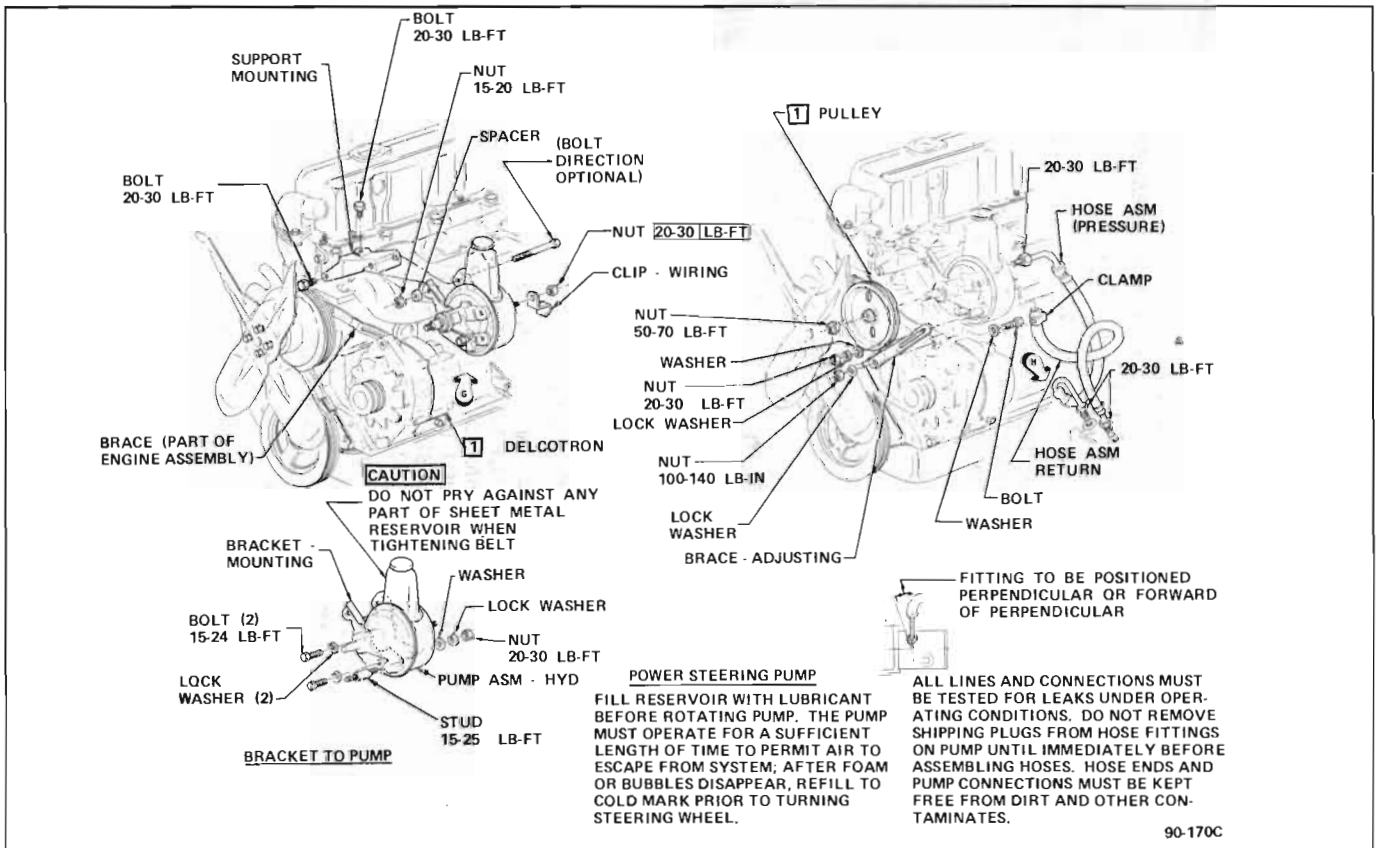

Figure 90-71 Power Steering System - 43-44000 Series L-6

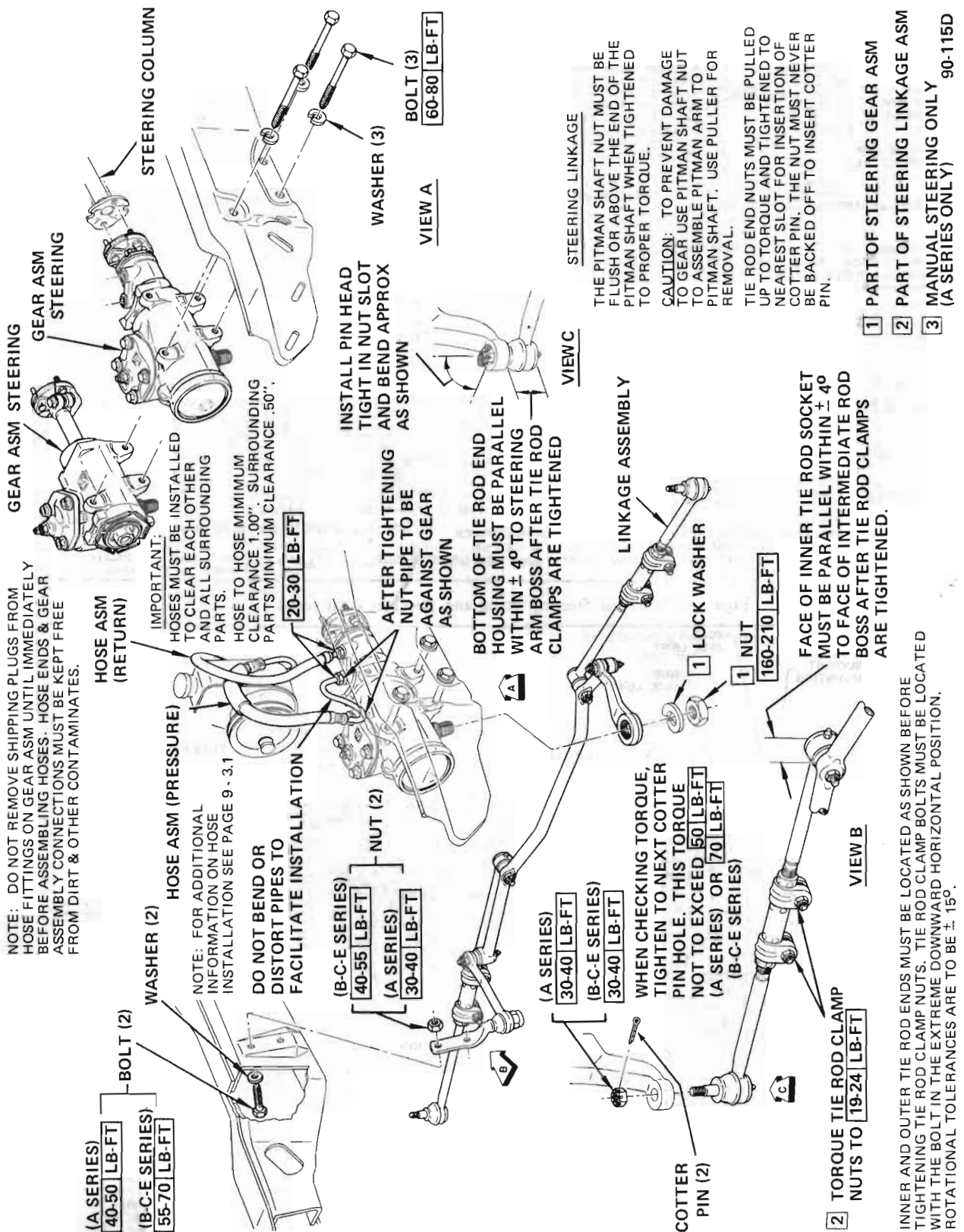
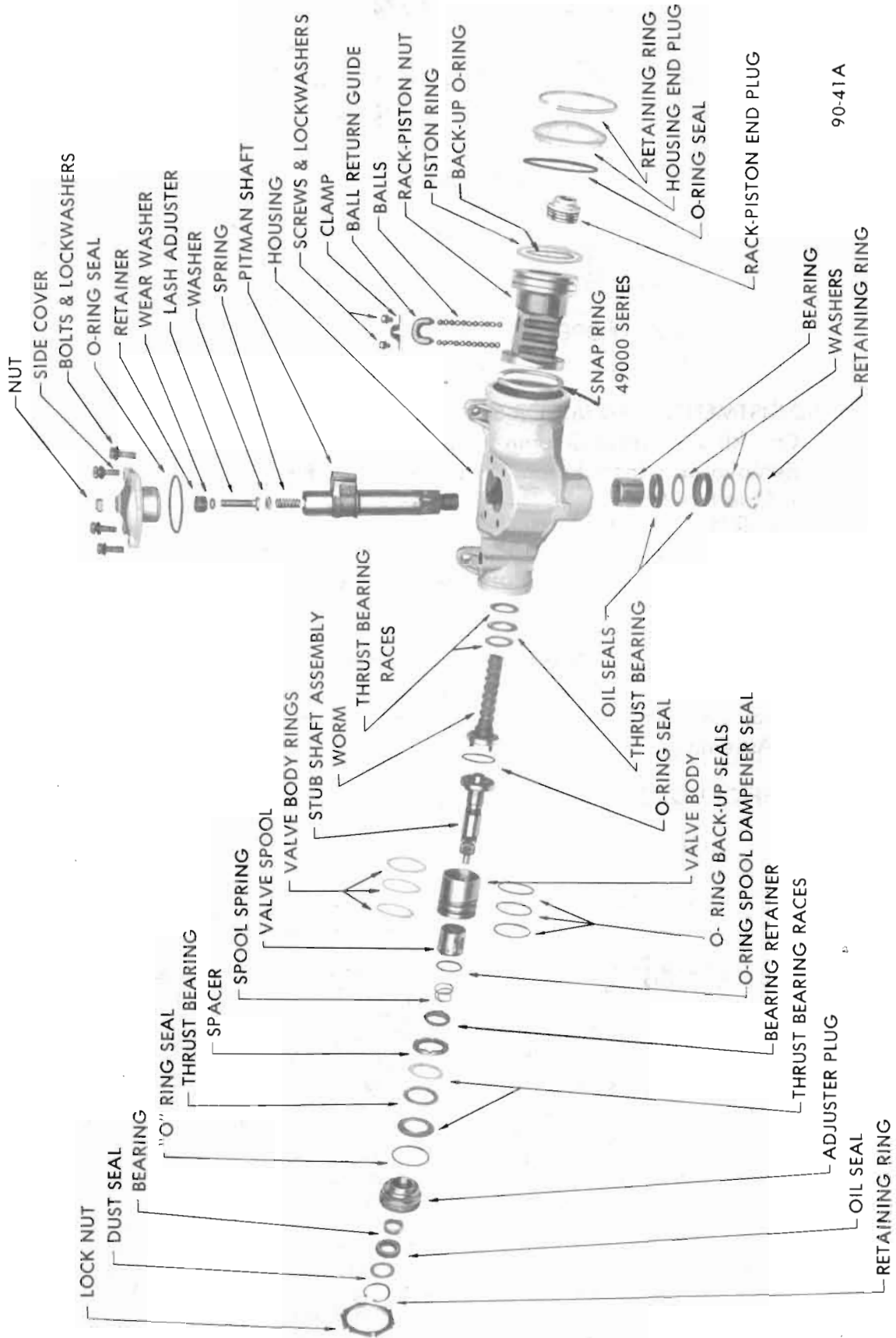

Figure 90-72 Power Steering Gear and Linkage - All Series



90-41A

Figure 90-73 Power Steering Gear (Exploded View)