

SECTION D

Automatic Climate Control Heater - Air Conditioner System 45-46-48-49000 Series

CONTENTS

Division	Subject	Paragraph
I	TROUBLE DIAGNOSIS:	
	General Information	13-60
	Testing A.C.C. System Using Tester J-23678	13-61
	A.C.C. System Troubleshooting Objective	13-62
	Preliminary Troubleshooting Information	13-63
	Troubleshooting Procedure	13-64
	Calibration Procedure Using Tester J-23678 and Tool J-21530	13-65
	On the Bench Troubleshooting Procedure for Programmer Trouble Diagnosis Guide	13-66 13-67
II	DESCRIPTION AND OPERATION:	
	Glossary of A.C.C. Terms	13-68
	General Theory of System Operations	13-69
	Basic System Operation	13-70
	Electrical System Operation	13-71
	Vacuum System Operation	13-72
III	ADJUSTMENTS AND MINOR SERVICE:	
	Adjustment of Programmer, Link Assembly, and Temperature Door	13-73
	Temperature Dial Calibration	13-74
IV	REMOVAL AND INSTALLATION:	
	Dash Control Assembly	13-75
	Blower Motor and Air Inlet Assembly	13-76
	Heater Assembly or Heater Core	13-77
	In-Car Sensor	13-78
	Programmer	13-79
	Programmer Components	13-80
V	OVERHAUL AND MAJOR SERVICE: (Not Applicable)	-
VI	SPECIFICATIONS: (Not Applicable)	-

DIVISION I

TROUBLE DIAGNOSIS

13-60 GENERAL INFORMATION

The following trouble diagnosis applies only to those components which make up the Automatic Control System. Information on diagnosing and correcting components which are a part of the Heater Air Conditioner System is contained in Section C.

13-61 TESTING A.C.C. SYSTEM USING TESTER J-23678

This tester has been designed and developed to be used in troubleshooting the Automatic Climate Control System in the car. The tester can be used to isolate the problem to the control head, the sensor string, the A.C.C. vacuum system, or the programmer. If a problem is determined to be in the programmer, the tester can also be used to completely troubleshoot each component in the programmer.

A hard rubber, dummy plug, two sizes of vacuum tees, and a supply of hose unions are located in the tester's storage compartment. The rubber dummy plug is used to plug all of the vacuum ports on the programmer, except the raw vacuum input for isolating a vacuum problem between the programmer and the A.C.C. vacuum system. The tees and unions are used to connect the rubber hose from the tester's vacuum gauge into the system to make various vacuum checks.

The wiring harness from the tester is actually a "patch cable", which can be plugged into the programmer and into the car electrical harness.

The voltmeter on the tester's panel is a 0 to 15 volt meter. The voltage monitored by the meter is controlled by the "voltage" knob just below the meter at all times, *except when* the "Temperature Dial Calibration" switch is in the calibrate position. The "No. 2 Feed" position allows the tester to directly monitor the input voltage to the programmer. The "No. 6 Blower" position allows the tester to directly monitor the voltage applied to the blower motor. The "No. 7 Lo-Relay" position indicates that the lo-relay has energized and that the relay contacts have closed if battery voltage is read on the meter. The "No. 8 Auto-Relay" position indicates that the auto-relay has energized and that the relay contacts have closed if battery voltage is read on the meter. The "Probe and Clip" position connects the probe and clip in the tester's storage compartment directly to the voltmeter. This makes it possible to use the voltmeter to check various other voltages in the A.C.C. system. The red probe should always be connected to the more negative terminal.

When the "Manual-Automatic" toggle switch is in the automatic position, the tester monitors voltages on the voltmeter according to the "Voltage" knob position when the "Temperature Dial Calibration" switch is in the "Off"

position. When the "Manual-Automatic" toggle switch is in the manual position, the temperature dial on the control head, the ambient sensor, and the in-car sensor are *disabled* and the "Manual Control" knob replaces them. The numbers around the "Manual Control" knob represent the resistance in ohms that is replacing the resistance of the temperature dial, the ambient sensor, and the in-car sensor. If the knob is rotated to the "Max. Cold" position, the programmer should move to the full A/C position. If the knob is rotated to the "Max. Heat" position, the programmer should move to the maximum heat position. *The "Manual Control" knob is operational ONLY when the "Manual-Automatic" toggle switch is in the "Manual" position.*

When the "Temperature Dial Calibration" switch is in the calibrate position, the voltmeter monitors the voltage directly across the temperature dial on the control head. When the "Compare" button is pressed, the voltmeter reads the voltage across a precision resistor in the tester. By moving the temperature dial on the control head, the two voltage readings can be made the same. After this is accomplished, the temperature dial on the control head should read the correct temperature, as indicated on the tester panel. If it does not, the temperature dial clutch should be held and the dial slipped to read the correct temperature (see Temperature Dial Calibration Procedure).

NOTE: *The "Temperature Dial Calibration" switch should always be in the "Off" position, unless the temperature dial on the control head is being calibrated.*

13-62 A.C.C. SYSTEM TROUBLESHOOTING OBJECTIVE

The main objective when troubleshooting an A.C.C. system is to isolate the problem to either the control head, the sensor string, the A.C.C. vacuum system, or the programmer. After this preliminary isolation is completed, the actual problem can then be diagnosed quickly.

The programmer *should not* be removed from the car, unless the problem has been isolated positively as being in the programmer. If the programmer is defective, it should either be repaired at your Buick dealership or sent to a United Delco Service Account which is authorized to make repairs on these units. *Programmers cannot be returned under warranty - they must be repaired.*

13-63 PRELIMINARY TROUBLESHOOTING INFORMATION

The most important part of diagnosing a problem is to determine exactly what the complaint is and whether this complaint actually stems from a malfunction in the system. Because of this, before attempting a repair, the serviceman should read through the General Operation section on the A.C.C. system to be sure that he has a thorough understanding of how the system is supposed to operate.

If a customer is complaining of a malfunction in the

A.C.C. system that occurs only periodically, the malfunction should be observed before the repair is attempted. This will greatly reduce the diagnosis time and eliminate a possible "comeback" because the wrong part was changed.

NOTE: Do not skip any steps in the Troubleshooting Procedure, unless instructed to do so.

13-64 TROUBLESHOOTING PROCEDURE

1. Start the car and place the control head selector lever in the "Auto" position and the temperature dial at 75. Allow enough time for the car engine to warm up and A.C.C. system to come on if the system was acting normally. If the system does not come on, skip to Step 3.

2. After the system has turned on, rotate the temperature dial slowly back and forth looking for abnormal operation of the system. Then move the selector lever to each of the various positions and look for any malfunction in the system's operation. By observing any malfunctions and noting when they occur, often times the serviceman will be able to isolate the problem to a certain area of the system.

3. Remove the cover of the programmer (while it is still mounted in the car) and connect J-23678 A.C.C. Tester electrical harness to the programmer and the car harness.

4. Place the control head selector lever in the "Auto" position and the temperature dial on 75.

5. On the tester, place the "Temperature Dial Calibrator" switch in the "Off" position and the "Manual-Automatic" switch in the "Manual" position.

6. Rotate the "Manual Control" knob to Max. Heat". The programmer should move to the full heat position and the fan should run at high-blower speed. (The vacuum motor mechanism will move into the vacuum motor.) Rotate the knob to "Max. Cold". The programmer should move to the full A/C position and the fan should run at high-blower speed. (The vacuum motor mechanism will move out of the vacuum motor.) If only partial programmer movement occurs, or "Hi Blower" is not obtained at both extremes, make the air mix door link adjustment *before* proceeding to the next step. If the programmer does *not* move at all, skip to Step 9.

7. Rotate the "Manual Control" slowly counterclockwise. The vacuum motor mechanism should first start to move at precisely 180 ohms (plus or minus 1 ohm) on the "Manual Control" knob. If this first movement occurs before or after 180 ohms, make the programmer amplifier calibration (feedback "pot" adjustment).

8. Rotating the "Manual Control" knob to the "Max. Cold" position should cause the system to shift to full A/C operation and the vacuum motor mechanism will move out of the vacuum motor. If the programmer moves normally when rotating the "Manual Control", skip to Step 11.

Programmer Does Not Move

9. On the A.C.C. Tester, place the "Temperature Dial Calibration" switch in the "Off" position and the "Voltmeter" control in the "Programmer 12-V Supply" position. Battery voltage should appear on meter. No voltage indicates the *lack of* a ground on terminal No. 1 of the programmer or the *lack of* battery supply to terminal No. 2 of the programmer.

10. Plug the tester's dummy vacuum plug on the programmer vacuum valve. Connect the dummy hose to the vacuum supply hose (Port No. 2) in the car vacuum harness. Make sure vacuum is present. The programmer now has vacuum supply with no car vacuum system components connected. If the programmer functions using the "Manual Control" on the tester, troubleshoot the A.C.C. vacuum system. If the programmer does not function, the defect is in programmer. Remove the dummy plug and reconnect the vacuum harness after making this test.

Sensor String Test

11. Place the control head selector lever in the "Auto" position and the temperature dial on 75.

12. On the J-23678 A.C.C. Tester, place the "Manual-Automatic" switch in the "Auto" position.

13. Observe the position of the vacuum motor mechanism.

14. On the A.C.C. Tester, switch the "Manual Automatic" switch to the "Manual" position and then adjust the "Manual Control" knob until the vacuum motor mechanism assumes the same position as it had in Step 13. When the "Manual Control" knob is properly adjusted, switching the "Manual-Automatic" switch back and forth will result in no movement of the vacuum motor mechanism.

15. Read the setting of the "Manual Control". This resistance reading is the same as the resistance of the two sensors and the temperature dial combined and should be 120 to 150 ohms at 70 to 75 degrees F. room temperature. If this reading is incorrect, try calibrating the temperature dial. If the calibration can be accomplished, then the temperature dial is "good". Visually check the ambient and in-car sensors for shorts or bad connections.

Lo Relay Test

16. Place the A.C.C. Tester's "Temperature Dial Calibration" switch in the "Off" position and the "Voltmeter" knob in the "Lo Relay" position.

17. Place the control head selector lever in the "Vent" or "De-Ice" position. If the "Lo Relay" is energized, the voltmeter will read battery voltage. The "Lo Relay" is operated by: 1) Hot engine thermal switch; 2) Hot in-car temperature switch; 3) Control head in "Vent" or "De-Ice" position. If the relay does *not* energize in the control head "Vent" or "De-Ice" position, the relay or the control head switch is defective.

Programmer Blower Switch Test

20. Place the A.C.C. Tester's "Temperature Dial Calibrator" switch in the "Off" position, the "Voltmeter" knob in the "Blower" position, and the "Manual-Automatic" switch in the "Manual" position.

21. Using the "Manual Control" move the programmer from full heat to the full A/C position. The voltage at the blower (coming from programmer terminal No. 5) should be battery voltage in full heat. As the programmer moves from full heat, the voltage should drop in steps, indicating different blower speeds, and then increase in steps to battery voltage in full A/C. If the voltage steps are not present or battery voltage is not indicated on the tester voltmeter when in full heat and full A/C operation, then the programmer is defective.

13-65 CALIBRATION PROCEDURE USING TESTER J-23678 AND TOOL J-21530

Preliminary Calibration Information

Be sure to allow sufficient time for the car engine to warm up and for the system to turn on before attempting calibration. *Do not skip any steps in the Calibration Procedure.*

Temperature Dial Calibration

1. Connect the A.C.C. Tester J-23678 into the wiring harness and the programmer.

2. Place the control head selector lever in the "Vent" position.

3. Place the "Manual-Automatic" switch on the tester in the "Manual" position.

4. Place the "Temperature Dial Calibrator" switch on the tester in the "Calibrate" position.

5. Note the voltmeter reading.

6. Press the "Calibrate" button and note the voltmeter reading.

7. With the "Calibrate" button pressed in, rotate the temperature dial on the control head until the voltmeter reading is the same as it was in Step 5 (when the button is not pressed in).

8. The temperature dial should be set at the temperature dial setting on the tester panel. If it does not, use Tool No. J-21530 to hold the gear on the left side of the temperature dial and slip the temperature dial to the correct setting. If the temperature dial cannot be calibrated using this procedure, it is defective.

Programmer Amplifier Calibration (Feedback Pot Adjustment)

1. Remove the plastic cover from the programmer while it is still mounted in the car.

2. Connect the A.C.C. Tester J-23678 into the wiring harness and the programmer.

3. Place the control head selector lever in the "Auto" position.

4. Place the "Manual-Automatic" switch on the tester in the "Manual" position.

5. Place the "Temperature Dial Calibrator" switch of the tester in the "Off" position.

6. Rotate the "Manual Control" knob on the tester to the "Max. Heat" position. The programmer should move to the full heat position.

7. Rotate the "Manual Control" knob to 180 and **STOP. DO NOT OVER-TRAVEL.**

8. Using a blade-type screwdriver, slip the shaft of the feedback potentiometer fully counterclockwise to its stop (see Figure 13-120 for location of the feedback potentiometer in the programmer). The vacuum motor mechanism will be "in" the vacuum motor indicating full heat operation.

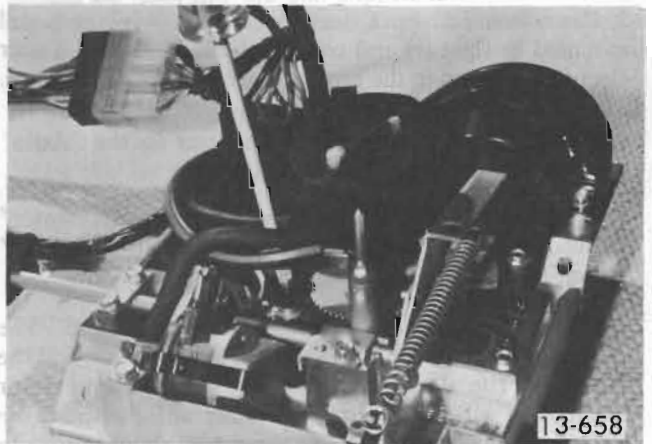

Figure 13-120 Feedback Potentiometer Adjustment

9. Using the screwdriver, very slowly slip the feedback potentiometer clockwise until the first movement of the vacuum motor mechanism can be seen. Stop the adjustment when the movement first occurs. (Do not watch the programmer output shaft.)

10. To check the adjustment, rotate the "Manual Control" knob to the "Max. Heat" position. Then slowly rotate the "Manual Control" knob counterclockwise and the vacuum motor mechanism should first start to move when the "Manual Control" knob is exactly at 180 plus or minus 1.

Touch up the feedback potentiometer adjustment in the programmer so that the mechanism movement occurs exactly at 180. If this adjustment cannot be made, the programmer is defective.

13-66 ON-THE-BENCH TROUBLESHOOTING PROCEDURE FOR PROGRAMMER

Equipment Required

1. A good filtered D.C. Power Supply, rated at 5 amperes at 12 volts.
2. Kent-Moore No. J-23678 Automatic Temperature Control Tester.
3. Vacuum Supply, capable of 20 inches of Hg. or more (Kent-Moore No. J-5428-03 or No. J-23178 or equivalent).
4. 1/4" hollow socket spin tight.
5. Medium size blade screwdriver.
6. Long-nose pliers.
7. Electrical test connector (Kent-Moore No. J-23713).

Refer to Figure 13-190 for identification of all programmer components. Before attempting to repair or adjust a programmer, locate the "output shaft", the "feedback potentiometer", the "vacuum motor", the "blower switch", the "vacuum checking relay", the "transducer", and the "rotary vacuum valve".

When following the troubleshooting procedure, do not skip any steps unless instructed to do so.

The A.C.C. tester "Manual-Automatic" switch should always be in the "Manual" position and the "Temperature Dial Calibration" switch should always be in the "Off" position when troubleshooting the programmer on the bench.

1. Plug the male connector of the A.C.C. Tester electrical harness into programmer.
2. Plug the electrical test connector No. J-23713 into female connector of A.C.C. tester electrical harness.
3. Plug the hard rubber dummy plug from the tester onto the programmer rotary valve and then connect it to the vacuum supply. Turn on the vacuum supply to 20 inches Hg. or more.
4. Connect the positive lead of a 12-volt DC power supply altered to the yellow wire from electrical test connector and connect the negative lead of the supply to the black wire of the test connector. The "Voltage" knob of the tester should read 12 volts when in the "No. 2 Feed" position, the "No. 7 Lo Relay" position, and the "No. 8 Auto Relay" position. If it doesn't, check the voltage supply and hook-up.
5. On the A.C.C. tester, place the "Manual-Automatic" switch in the "Manual" position and the "Temperature Dial Calibration" switch in the "Off" position.
6. Rotate the A.C.C. tester "Manual Control" knob from "Max. Heat" to Max. Cold". (Make sure the power supply

is adjusted for 12 volts DC and vacuum supply is at 20 inches Hg. or more.) The programmer output shaft should rotate 120 degrees (1/3 rotation of shaft) from maximum heat to maximum cold. If it does rotate normally, skip to Step 18.

7. If the programmer output shaft does not operate properly in Step 6, remove the cover of the programmer and reconnect the tester electrical connector and the rotary vacuum valve rubber dummy plug. Recheck programmer operation as described in Step 6. If the programmer output shaft now operates normally, look for pinched vacuum hose, loose electrical connection, pinched or shorted wires, shorted Darlington Amplifier heat sink, or a mechanical bind with the programmer cover. Be sure to tap the programmer components with the handle of a screwdriver to check for intermittent problems.

Amplifier Test

8. If the programmer output shaft still does not operate properly, place the "Voltage" knob of the tester in the "Probe and Clip" position. Connect the alligator clip lead to the transducer terminal with the gray wire.

CAUTION: *Do not short transducer terminals together or amplifier will be damaged.*

Push the probe into the programmer connector body making contact with terminal No. 2 which connects to a yellow wire.

9. Rotating the "Manual Control" knob from "Max. Heat" to "Max. Cold" (or vice-versa), the voltmeter reading should *change 5 volts or more* (after it is stabilized). This change indicates that the amplifier is "good". If the 5 volts or more change is *not* obtained, check the amplifier heat sink insulator for proper positioning.

NOTE: *If the heat sink is shorted to the programmer chassis, the programmer will go to the full AC position.*

If the voltage change cannot be obtained and the insulator is okay, check the calibration of the amplifier according to the instructions in Step 18. If the programmer still does not function properly, replace the amplifier circuit board and be sure to *install the new heat sink insulator properly.*

The new amplifier *must be calibrated* according to Step 18 after installation.

Transducer Test

10. If the 5 volts change was present in the amplifier check in Step 9, but the programmer output shaft does not operate normally, leave the "Probe and Clip" connected, as instructed in Step 8 *throughout Transducer Test Procedure.*

11. Disconnect vacuum hose from the small diameter port of the transducer and connect A.C.C. tester's hose to the vacuum gauge directly to this hose. About 20 inches Hg.

or more vacuum should be present on this transducer vacuum supply hose. If vacuum is proper, restore hose connection. If 20 inches Hg. or more is *not* present, check the vacuum supply vacuum level and then go to Steps 14, 15, 16, and 17 to check for vacuum leaks in the vacuum checking relay and the rotary vacuum valve.

12. To check for proper regulated vacuum output from the transducer, disconnect the long hose from the transducer to the vacuum checking relay *at the relay*.

NOTE: *This long hose must be at least 15 inches long, or the transducer will make a buzzing noise.*

Connect the A.T.C. tester's vacuum gauge directly to the long hose at the vacuum checking relay.

13. Position the programmer in an upright position so that the output shaft points straight up. With the "Manual Control" knob in the "Max. Heat" position, 0 volts should be read on the voltmeter and the vacuum should be 9 to 11 inches Hg. Turning the "Manual Control" knob to the "Max. Cold" position should make the vacuum drop to 0 inches Hg. and the voltage should increase 5 volts or more. If the above indications *do not occur*, the transducer is defective. After the check is completed, restore hose connection. Disconnect probe and clip from the programmer.

Rotary Vacuum Valve and Vacuum Checking Relay Test

14. Connect the tester's vacuum gauge into the vacuum feed line to the rubber dummy plug on the programmer rotary vacuum valve. Disconnect the center hose from the side port of the rotary vacuum valve and seal off the port by placing your finger over the port. The tester's vacuum gauge should read 20 inches Hg. or more. **If it does not**, either the vacuum checking relay or the rotary vacuum valve is leaky. If 20 inches Hg. or more vacuum is read, skip to Step 16 and restore the hose connection.

15. Remove all three hoses from the side ports of the rotary vacuum valve. Remove the short hose from the transducer and connect it across the two outer ports on the side of the rotary valve. Place finger over center side port of the rotary vacuum valve. If the tester's vacuum gauge now reads 20 inches Hg. or more, the *vacuum checking relay* is defective. If it does *not*, the rotary valve is defective and leaking. After repair of programmer, restore all hose connections.

Vacuum Motor and Vacuum Checking Relay Test

16. Disconnect electrical connector from programmer. *Do not disconnect* the vacuum input to programmer. The programmer should go to the full heat position (the vacuum motor mechanism will move into the vacuum motor). If it does not, then either the vacuum checking relay or the vacuum motor has a severe leak. If it does go to full heat, a slight leak may be present and the vacuum motor will move toward "Max. Cold" after removing the rubber dummy plug from the programmer.

17. If the vacuum motor mechanism moves, the vacuum motor or vacuum checking relay is leaking. Disconnect the short hose at vacuum motor. Apply raw vacuum to the vacuum motor input port, then pinch the hose at the vacuum motor with long nose pliers and hold for 30 seconds. If the mechanism moves, the vacuum motor is defective. If it does *not* move, the vacuum checking relay is defective.

Amplifier Calibration (Feedback Pot Adjustment)

18. a. Remove the programmer cover and make the connections to programmer, as described in Steps 1 through 4.

b. Using a screwdriver, slip the shaft of the feedback potentiometer, turning the shaft fully counterclockwise (gear does not move). See Figure 13-120. The vacuum motor should now be in the "Full Heat" position. (The vacuum motor mechanism will move into the vacuum motor.)

c. Place the "Manual-Automatic" switch in "Manual" position. Rotate the "Manual Control" to the "Max. Heat" position.

d. Carefully adjust the "Manual Control" to "180" and *do not overshoot*.

e. Slip the shaft of the feedback "pot" very slowly clockwise looking for signs of *vacuum motor*, *mechanism movement*. (Do not watch the output shaft.) Stop the adjustment when movement first occurs.

f. Check the adjustment with the "Manual Control". Rotate the "Manual Control" to the "Max. Heat" position. Watch for signs of vacuum motor mechanism movement while slowly rotating the "Manual Control" back toward "180". The first sign of movement should occur when the "Manual Control" knob is exactly on "180". Touch up the feedback potentiometer adjustment in the programmer so that the mechanism movement occurs exactly at "180".

Programmer Blower Switch Test

19. Place the "Voltage" knob in the "No. 6 Blower" position. Rotate the "Manual Control" knob to the "Max. Heat" position. The voltmeter reading should be 12 volts DC (supply voltage). As the "Manual Control" knob is slowly rotated toward "Max. Cold", at about "175", the voltage will drop slightly. Then at about "160" the voltage will again drop slightly and at about "155", the voltage will again drop slightly. At about "130", the voltage will increase slightly. At about "120", the voltage will again increase slightly and again at about "110", a slight increase should be noted. If these steps in blower voltage are not present, the blower switch in the programmer is defective.

20. Tap the components of the programmer while rotating the "Manual Control" knob and watch for any erratic operation due to intermittent problems. Replace program-

mer cover and rotate "Manual Control" knob, checking for normal rotation of the output shaft.

13-67 TROUBLE DIAGNOSIS GUIDE

Blower Inoperative

Possible Causes

Disconnected loose or corroded blower ground wire.

Disconnected feed wire.

Defective blower.

Defective fuse.

Defective blower switch in programmer.

NOTE: Test programmer with Tester J-23678.

Blower, Programmer, and Compressor Inoperative

Possible Causes

Connection broken at:

Engine Harness Connector Plug (No. 10 red wire and green wire)

Cluster Extension Harness to I/P Harness Connector Plug

Cluster Extension Harness to Body Extension Harness Connector Plug

Hi Blower Only MAX HEAT Position

Possible Cause

Disconnected plug at programmer.

Lo Blower Only

Possible Causes

Disconnected plug at control head to body extension harness.

Disconnected plug at auto relay.

No LO Blower in OFF, VENT, and LO Positions

Possible Causes

Disconnected plug at the lo relay.

Defective relay.

Immediate Lo Blower - Car Start-Up - In-Car Temperature Below 80 Degrees

Possible Causes

Disconnected plug at engine thermal switch.

Defective engine thermal switch.

Immediate Lo Blower - Car Start-Up - In-Car Temperature Above 80 Degrees

Possible Causes

Check preceding causes.

Disconnected plug at heater delay relay.

Wrong or defective heater delay relay.

Low Blower Inoperative All Positions

Possible Cause

Grounded wire or defective engine thermal switch.

Compressor Inoperative Above 32 Degrees Ambient

Possible Causes

Disconnected ambient switch.

Defective ambient switch.

Disconnected plug at compressor.

Defective compressor coil.

Missed terminal in engine harness connection.

Compressor Operates Below 32 Degrees

Possible Causes

Shorted ambient switch.

Shorted wire in compressor circuit.

Defective compressor clutch.

Maximum Heat Mode AUTO RANGE Positions - No Temperature Control - No Automatic Blower Changes

Possible Causes

Disconnected ambient sensor.

Disconnected in-car sensor.

NOTE: Buzzing of programmer transducer may occur when selector lever is changed to "VENT" position.

Disconnected vacuum hose in programmer - vacuum valve to checking relay (purple).

Maximum Heat Mode All Positions - No Temperature Control - No Automatic Blower Changes*Possible Cause*

Disconnected vacuum plug at:

Control Head (Vacuum)

Programmer (Vacuum)

Main Vacuum Harness Connector

Vacuum Manifold defective

Maximum Heat Mode and Cold Air From Heater Outlet*Possible Causes*

Disconnected vacuum hose in programmer - vacuum valve to checking relay (black).

Disconnected vacuum hose at vacuum source line (black at firewall).

Defective vacuum manifold.

Max. A/C All Positions*Possible Causes*

Shorted ambient sensor.

Shorted in-car sensor.

Disconnected vacuum hose in programmer at:

Source to transducer (short black hose).

Vacuum motor to transducer (black and white hose).

Max. A/C Only in AUTO RANGE Positions Cold Air Out of Outlets*Possible Cause*

Disconnected vacuum hose in programmer - vacuum motor to checking relay (yellow) - shorted sensor string.

Erratic Temperature Control*Possible Causes*

Kinked or disconnected aspirator hose.

Defective programmer.

Defective control head.

NOTE: Test programmer with Tester J-23678.

Temperature of Discharge Air Too Hot or Too Cool at Mode Change*Possible Cause*

Misadjusted temperature door linkage.

Insufficient Heat*Possible Causes*

Misadjusted temperature door linkage.

Defective water valve.

Defective engine thermostat.

Low coolant.

Modes Will Not Change in AUTO RANGE Positions From A/C to Heat*Possible Causes*

Black and grey vacuum source lines switched.

Disconnected source vacuum hose to reservoir.

Leaking vacuum reservoir.

Excessive Temperature Difference at Outlets Bi-Level Operation (Left Outlet Warmer Than Center)*Possible Cause*

Vacuum lines switched at upper and lower mode door diaphragms.

Partial Air Flow to Windshield in DEICE and No Air Flow to Windshield in DEFOG Position*Possible Cause*

Vacuum lines to defroster (dual) diaphragm switched.

NOTE: Normal de-fog operation has a delay before door opens.

No Air Flow to Windshield in Either DEFOG or DEICE Position*Possible Causes*

Either vacuum line to defroster diaphragm disconnected.

Leaking dual diaphragm.

DIVISION II

DESCRIPTION AND OPERATION

13-68 GLOSSARY OF A.C.C. TERMS

Incar Sensor *This is a semi-conductor type thermister whose resistance varies inversely with temperature. This sensor is mounted on the instrument panel and is aspirated (air is circulated past it). This is the most sensitive of the two sensors.*

Ambient Sensor *This is a semi-conductor type thermister whose resistance varies inversely with temperature. This sensor is mounted in the duct work to monitor the incoming air temperature.*

Ambient Switch *This switch allows the AC compressor to be activated whenever the ambient temperature is above 32 degrees F.*

Engine Thermal Switch *This bi-metal thermal switch is mounted on the engine block. Whenever the engine water temperature is above 120 degrees F, this switch is opened and the Automatic Climate Control system is allowed to turn on.*

Blower *This is the blower which draws in outside air and forces it into the passenger compartment.*

Air Mix Door *This door is located in the duct work and is controlled by the A.C.C. programmer. Its position determines the temperature of the air which is being distributed into the passenger compartment by blending hot and cold air.*

Outside Air Door *This door is open, allowing outside air to be drawn into the duct work in all modes of operation except air conditioning recirculation. When in this mode, the outside air door is closed and the passenger compartment air is recirculated through the duct work for maximum cooling.*

Defrost Door *This door is located in the duct work and controls the amount of air distributed to the windshield. This door has three positions and is controlled by a dual vacuum diaphragm. The three positions are: 1) Closed; 2) Partially Open; and 3) Open.*

Lo Relay *This relay is located on the firewall in the engine compartment and is energized whenever the control head is in "Vent" or "De-Ice", or the incar temperature switch is closed, or whenever the engine thermal switch is opened. This allows the blower motor to operate at low blower speed. It is possible for the lo relay to be energized whenever the ignition switch is in the "On" position, but the control head selector lever is in the "Off" position.*

Lower Mode Door *When no vacuum is supplied to the diaphragm controlling this door, air is distributed from*

the heater ducts. When vacuum is supplied to this diaphragm, air is distributed from the A/C outlets.

Upper Mode Door *When no vacuum is supplied to the diaphragm controlling this door, air is distributed from the A/C outlets. When vacuum is supplied to the diaphragm, air is distributed from the heater ducts.*

Auto Relay *This relay is energized whenever the engine thermal switch, the incar temperature switch, or the control head is in "Auto", "High", "De-Fog", or "De-Ice" positions. This allows the system to automatically vary the blower speed from low to high blower.*

Hot Water Vacuum Valve *This valve is located in the engine compartment and controls the flow of water into the heater core. Vacuum to this valve is supplied from the programmer rotary vacuum valve. Vacuum applied to the valve stops the water flow.*

Outside Air Door Vacuum Diaphragm *This diaphragm is controlled by the programmer rotary vacuum valve and determines the position of the outside air door. The door is closed to outside air when vacuum is applied (recirculation mode).*

Defrost Door Vacuum Diaphragm *This dual vacuum diaphragm controls the position of the defrost door. When the system is in "De-Fog", vacuum is applied through a restrictor to the side port of the diaphragm. When the control head is in the "De-Ice" position, vacuum is applied to both ports from the control head vacuum valve.*

Heater Delay Relay *This relay is energized whenever the engine water temperature is above 120 degrees F. When the relay is energized, the lo relay coil is grounded, energizing it, and a ground is provided to the control head switch.*

Restrictor *This is a porous sintered metal plug that is installed in the vacuum harness in the outer port of the defroster vacuum diaphragm and in the recirc vacuum hose. This produces a delay in vacuum being applied to the diaphragms.*

Compressor Clutch *This clutch is part of the compressor assembly and is activated when power is applied to it. When the clutch is activated, the compressor will operate, resulting in air-conditioned air in the duct work.*

Control Head *This is the unit which protrudes through the instrument panel and allows the owner of the car to control the operation of the automatic temperature control system.*

Control Head Vacuum Valve *This valve is located toward the rear of the control head and controls vacuum being supplied to the defroster, lower-mode and upper-mode doors. All of the ports on this valve are vented when in the "Off" position, except ports 1, 4, and 9.*

Control Head Selector Lever *This lever is located on the control head and allows the customer to select the desired mode of operation of the automatic temperature control system.*

Temperature Dial *This thumbwheel dial allows the customer to select the temperature which he desires in the passenger compartment.*

Incar Temperature Switch *This temperature-sensitive switch is located either on the control head or at the incar sensor. Whenever the incar temperature is above 80 degrees F, this switch is closed and allows the Automatic Climate Control system to turn on immediately for instant air conditioning.*

Car Vacuum Harness *This includes all of the vacuum lines controlling the Automatic Climate Control system that are external to the programmer.*

Car Electrical Harness *This includes all of the electrical wiring for the Automatic Climate Control system that is external to the programmer.*

Car Ignition Switch *This is the on-off switch which is located on the steering column of the car. When the switch is in the "Run" position, power is applied to the programmer.*

Car Fuse Block *This block is located under the dash of the car and contains a 25 ampere fuse which fuses the Automatic Climate Control system.*

Door Link *This link is connected between the programmer output shaft and the air-mix door arm. The link is adjusted at the programmer end and has a retainer disconnect at the temperature door end.*

Programmer *This unit is located under the dash behind the glove box and controls the blower speeds, the air-mix door, and vacuum diaphragms.*

Vacuum Motor *This is the vacuum diaphragm which is located inside the programmer. The modulated vacuum from the transducer results in movement of the vacuum motor which controls the position of the output shaft of the programmer, the programmer vacuum valve, the amplifier feedback "pot", and the blower speed.*

Amplifier Circuit Board *This circuit board is located in the programmer and amplifies the DC signal supplied from the sensor string. The output of the amplifier controls the operation of the transducer.*

Programmer Blower Switch *This set of contacts is located in the programmer and moves as the vacuum motor moves. These contacts complete the electrical circuit to the blower motor.*

Vacuum Checking Relay *This vacuum relay is located in the programmer. If the manifold vacuum supplied to the programmer is lost, the relay will check or hold the*

vacuum to the vacuum motor. Also, the vacuum supplied to the car vacuum diaphragms is sealed off, preventing them from shifting position.

Transducer *This unit is located in the programmer. The electrical current supplied from the amplifier is transformed into a vacuum signal in the output of the transducer. This vacuum output controls the movement of the vacuum motor. No current gives 9 to 11 in. Hg. and current reduces the vacuum level.*

Programmer Output Shaft *This shaft extends from the programmer approximately four inches. Movement of this shaft controls the position of the air-mix door via the door link.*

Feedback Potentiometer *This potentiometer is part of the amplifier circuit board. Movement of the vacuum motor changes the resistance of this potentiometer, cancelling out resistance changes in the sensor string.*

Feedback Potentiometer Arm Mechanism *This mechanism is connected to the vacuum motor and drives the feedback potentiometer as the vacuum motor moves.*

Power Spring *This spring connects to the vacuum motor mechanism and extends to a retainer at the edge of the programmer housing. When the vacuum motor diaphragm is vented, the spring positions the vacuum motor in the full A/C position.*

Mylar Heat Sink Insulator *This insulator covers the heat sink of the Darlington amplifier located on the amplifier circuit board. The insulator prevents the heat sink from being grounded to the programmer housing.*

Programmer Vacuum Valve *This vacuum valve is controlled by the vacuum motor and supplies vacuum to the control head and the other vacuum diaphragms in the system.*

Vacuum Valve Spring *This spring is located in the programmer directly beneath the programmer vacuum valve and holds the feedback potentiometer arm mechanism in place.*

Heat Sink Retainer *This retainer clips over the side of the programmer housing and holds the heat sink of the Darlington amplifier in the proper position.*

Control Head Base Plate *This plate is mounted to the back of the control head face. The selector lever and the control head vacuum valve are mounted on this plate.*

Conditioned Air *Conditioned air is hot and cold air which has been blended in the ductwork and is distributed from the outlets, providing the proper comfort level in the passenger compartment.*

Darlington Amplifier *This is a two-transistor circuit contained in one package which serves as the power amplifier for the signal provided to the transducer.*

Bi-Level Operation This occurs when the passenger compartment temperature is stabilized and the blower is operating at low speed. Conditioned air flows from both the A/C and heater outlets.

13-69 GENERAL THEORY OF SYSTEM OPERATION

A.C.C. is designed to automatically control the heating and air conditioning components in the automobile so that a constant interior temperature is maintained, regardless of varying ambient conditions. The Automatic Climate Control system is beneficial in both summer and winter. In hot weather, it will cool the car rapidly to the pre-set comfort level and then modulate cooling to whatever degree is required to maintain constant comfort. In mild weather, the interior of the vehicle remains comfortable without having to reset the controls. In cold weather, the system will heat the car quickly to the desired temperature, then level out to maintain the pre-set comfort level desired by the passengers.

The existing heater and air conditioning components provide a series system so that the primary control function is to position an air mix door and a mode door in order to release properly-heated or cooled air from the proper duct outlets.

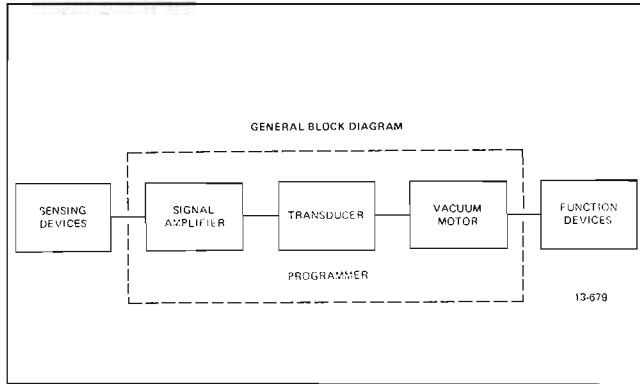

1. Sensing Devices - Thermistors
2. Programmer
 - a. Signal Amplifier - DC Transistor Amplifier
 - b. Transducer - Electrical to Vacuum Converter
 - c. Vacuum Motor - Vacuum-Powered Servo
3. Function Devices - Door Diaphragms, Air Mix Door, Hot Water Valve, Etc.

The purpose of the incar sensor and the ambient sensor is to monitor the air temperature of the environment in which they are situated. They are semi-conductor material thermistors whose resistance varies inversely with temperature changes. These sensors are connected in series with the temperature dial potentiometer which is located on the control head. Whenever the resistance of any of these three devices changes, a new signal is sent to the three-stage DC amplifier.

The DC amplifier enlarges or amplifies the signal supplied from the sensors and the temperature dial and feeds this strong signal to the transducer.

The transducer is actually a solenoid with a vacuum valve connected to the end of the plunger which is located inside the windings. The plunger is positioned inside the winding, depending upon the amount of current flow from the amplifier. The transducer plunger is spring-loaded so that with no current flow through the windings, the plunger is pulled out of the windings. When current flows through the windings, the plunger is pulled into the winding, causing the transducer vacuum valve to have a slight leak to outside air. This results in a lower vacuum level from the regulated vacuum port of the transducer (see Figure 13-121).

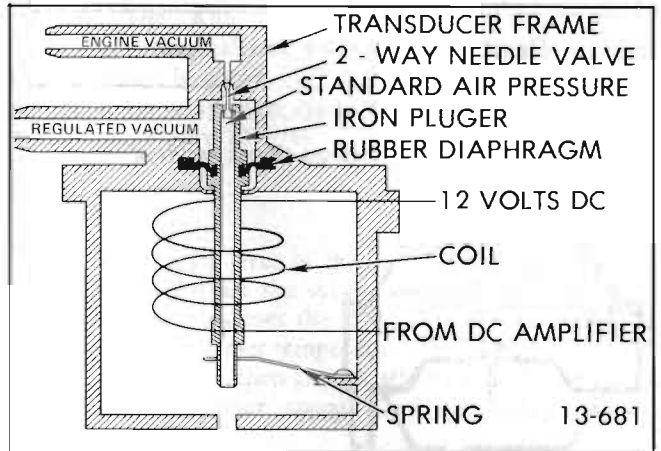

Figure 13-121 Cross Section - Transducer

If a decrease in current flow from the DC amplifier occurs, the plunger moves out of the winding, opening the transducer vacuum valve and resulting in more vacuum from the regulated vacuum port of the transducer.

The vacuum output from the transducer is fed to the vacuum checking relay. When engine vacuum is applied to the checking relay, the relay opens (Figure 13 122), allowing the regulated vacuum output from the transducer to be fed directly to the vacuum motor, positioning it. If engine vacuum to the checking relay is not present, the relay closes (Figure 13 123), sealing the vacuum applied to the vacuum motor. This locks the vacuum motor in place until engine vacuum is again applied to the vacuum relay.

The vacuum checking relay also has another section which checks the input vacuum to the door diaphragms whenever engine vacuum is not present. This holds the doors in place until the engine vacuum is again present.

The vacuum motor mechanism is positioned as the result of the vacuum from the transducer. The vacuum motor mechanism is directly connected to electrical wiper contacts that control the various blower speeds. The mechanism is also connected to a rotary vacuum valve in the programmer and also to an output shaft.

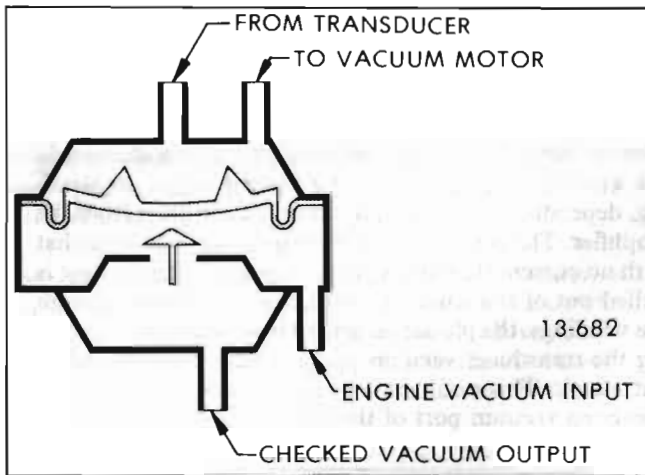

Figure 13-122 Checking Relay - Open

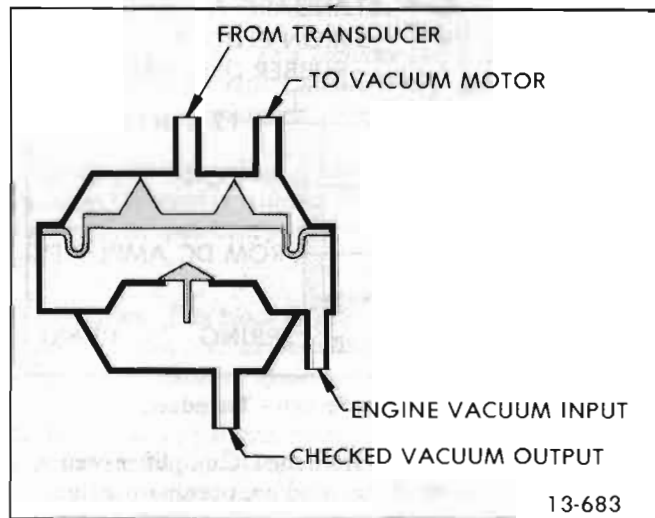

Figure 13-123 Checking Relay - Closed

The rotary vacuum valve channels vacuum to various vacuum diaphragms and to the rotary vacuum valve on the control head. The output shaft controls the position of the air-mix door, controlling the temperature of the air which is distributed into the passenger compartment.

As the vacuum motor in the programmer moves, a gear meshed with the mechanism rotates the amplifier feedback potentiometer. This potentiometer indicates when the vacuum motor has reached the proper position and cancels out the change in resistance of the sensor string or the temperature dial. This signals the amplifier to stop the movement of the vacuum motor.

Whenever an appreciable amount of variation in resistance occurs in the sensor string or the temperature dial, the vacuum motor moves to supply either warmer or cooler conditioned air to counteract the resistance change.

13-70 BASIC SYSTEM OPERATION

The numbers on the temperature dial thumbwheel control located on the control head indicate the various tempera-

tures which can be obtained in the passenger compartment of the car. This temperature dial serves the same function as the thermostat in your home. The temperature dial controls the in-car temperature when the selector lever is in the "Off", "Lo", "Auto", "Hi", "De-Fog", or "De-Ice" position. See Figure 13-124.

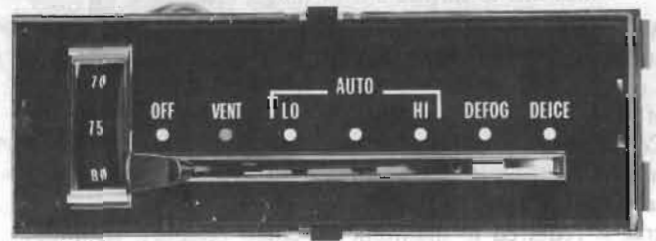

Figure 13-124 A.C.C. Control Panel

OFF Position

The 1971 Automatic Climate Control system is completely "shut off" when the ignition switch of the car is in the "Off" position. When the car ignition switch is turned on, the electrical circuit to the A.C.C. system is accomplished. With the control head selector lever in the "Off" position, the system will come on when the engine water temperature reaches about 120 degrees F, or if the inside car temperature reaches about 80 degrees F. The fan will run at "Lo Blower" speed and conditioned air will flow from the heater outlets. The temperature of the air depends on the temperature dial setting.

VENT Position

When the selector lever is in the "Vent" position, the system comes on immediately whenever the ignition switch is in the "Run" position. The blower runs at "Lo Blower" speed and outside air is distributed into the passenger compartment of the car through the A/C outlets.

LO Position

With the control head selector lever in the "Lo" position, the system will not come on until either the inside car temperature reaches about 80 degrees F, or the engine water temperature reaches about 120 degrees F. The blower will then operate at "Lo Blower" speed only. Conditioned air will flow from the A/C outlets, the heater outlets, or both when the system is in "Bi-Level" operation.

AUTO Position

The operation of the A.C.C. system when the selector lever is in the "Auto" position is the same as the "Lo" position, except that the blower is no longer locked in "Lo Blower" operation. The programmer will select any of the four blower speeds ("Lo", "Med. 1", "Med. 2", and "Hi") in order to maintain the proper comfort level in the car.

HI Position

When the control head selector lever is placed in the "Hi" position, the blower operates only at "Hi Blower" speed. The temperature selected on the temperature dial will be maintained inside the passenger compartment. If maximum A/C is required, the inside air will be recirculated through the A/C system for maximum cooling. When the system operation has stabilized and the blower is operating at lower speeds, the conditioned air will be distributed from both the A/C and heater outlets. This is "Bi-Level" operation.

DEFOG Position

The blower operates at "Lo", "Med. 1", "Med. 2", or "Hi" speeds when the control head selector lever is in the "De-Fog" position. The desired temperature level inside the car will be maintained. Conditioned air is distributed from the heater, A/C, and defroster outlets, resulting in "tri-level" operation. The system will come on immediately when the engine thermal switch or the incar temperature switch is closed.

DEICE Position

With the control head selector lever in the "De-Ice" position, the system comes on immediately when the ignition switch is turned on. The fan is locked on "Hi Blower" speed and all of the air is distributed from the defroster outlets onto the windshield. Some air is bled to floor on "Deice". The comfort level selected on the temperature dial will be maintained in the car.

13-71 ELECTRICAL SYSTEM OPERATION

OFF Position

When the control head selector lever is in the "OFF" position, the system is locked in "Lo Blower" operation when the ignition switch is in the "Run" position and the engine thermal switch is open, the heater delay relay is closed and the "Lo Relay" is closed. The engine thermal switch opens whenever the engine water temperature is above 120 degrees F. When the engine thermal switch opens, the heater delay relay springs close. If the temperature inside the car is above 80 degrees F, the incar temperature switch is closed, which also causes the "Lo Relay" to close, resulting in "Lo Blower" operation (see Figure 13-133).

With ignition switch in the "Run" position, power is supplied to the programmer, allowing it to operate. The incar sensor, the ambient sensor, and the temperature dial setting on the control head cause the programmer to move the air-mix door. The proper hot-cold air mixture is then distributed from the heater outlets, maintaining the incar temperature at the comfort level selected on the temperature dial.

VENT Position

With the ignition switch in "Run" and the selector lever in the "Vent" position, the "Lo Relay" will be closed and the system will come on immediately with the fan locked on "Lo Blower" speed. The vacuum motor in the programmer is in the A/C position, since the incar sensor and the ambient sensor are shorted out by the control head switch. The ambient switch is closed when the ambient temperature is above 32 degrees F. However, the compressor will not run, since no voltage is applied to it through the control head switch. The engine thermal switch is closed when the engine water temperature is above 120 degrees F. The incar temperature switch is closed if the incar temperature is above 80 degrees F. In "Vent" immediate start-up occurs, irrespective of temperature delay settings. The "Auto Relay" is always open in this mode. The engine thermal switch is open when the engine water temperature is above 120 degrees F, which closes the heater delay relay. This causes the "Lo Relay" to be energized (see Figure 13-134).

LO Position

With the selector lever in the "Lo" position, the system will come on when the incar temperature is above 80 degrees F, which closes the incar temperature switch, or when the engine water temperature reaches 120 degrees F. The "Lo Relay" is then closed, allowing the blower to be locked on "Lo Blower" speed. The "Auto Relay" remains open.

When the ambient temperature is above 32 degrees F, the ambient switch is closed, supplying voltage to energize the compressor clutch via the control head switch (see Figure 13-135).

AUTO Position

With the selector lever in the "Auto" position, the system will come on when the incar temperature is above 80 degrees F, which closes the incar temperature switch, or when the engine water temperature reaches 120 degrees F. The "Lo Relay" and the "Auto Relay" are both closed and the position of the blower wiper contacts in the programmer determines the speed at which the blower operates. When the ambient temperature is above 32 degrees F, the compressor clutch is energized via the ambient switch and the control head switch (see Figure 13-136).

HI Position

When the selector lever is in the "Hi" position, the system turn-on is the same as described in the "Auto" position section. Both the "Lo" and "Auto" relays are closed when the system is operating and a direct circuit path via the control head switch is connected from the battery circuit to the blower motor. This locks the blower on "Hi Blower" operation. When the ambient temperature is above 32 degrees F, the ambient switch is closed and the compressor clutch is energized. If the system is calling for

maximum cooling, the system will operate in the recirculation mode; however, there is no change in the electrical function when this mode is achieved (see Figure 13-137).

DEFOG Position

With the selector lever in the "De-Fog" position, the system turn-on is the same as described in the "Auto" position section. The "Lo" and "Auto" relays are both closed and the position of the blower wiper contacts in the programmer determines the speed at which the blower operates. When the ambient temperature is above 32 degrees F, the ambient switch is closed and the compressor clutch is energized (see Figure 13-138).

DEICE Position

With the selector lever in the "De-Ice" position, the system comes on immediately and the blower is locked on "Hi" speed. The "Lo Relay" and the "Auto Relay" always remain energized.

The temperature dial must be used to obtain maximum heat when it is desired to override the automatic control (see Figure 13-139).

13-72 VACUUM SYSTEM OPERATION

OFF Position

With the selector lever in the "Off" position and the engine running, the system is turned on whenever the engine thermal switch or the incar temperature switch is closed. The vacuum motor in the programmer moves to a position that will moderate the incar temperature. Air flows from the heater outlets at "Lo Blower" speed (see Figure 13-140).

VENT Position

Air is drawn in through the outside air door and is distributed from the A/C and defroster outlets at "Lo Blower" speed. The programmer is in the maximum A/C position (see Figure 13-141).

LO Position

When maximum cooling is required (see Figure 13-142), cold air is distributed from the A/C outlets. The blower is locked on "Lo Blower" speed. Recirculation of air is not possible in the "Lo" selector lever position. A small amount of this cold, dry air is also blown onto the windshield.

When the vacuum motor moves from maximum A/C, the porting in the programmer vacuum valve changes.

As the air temperature from the outlets reaches a moderate temperature, the system goes into "Bi-Level" operation and air flows from the A/C and the heater outlets.

Some moderate temperature, dry air is also released from the defroster outlets onto the windshield (see Figure 13-148).

When heating is required, hot air is distributed from the heater outlets. A small amount of hot, dry air is also released from the defroster outlets.

AUTO Position

Even though maximum A/C is required, the system cannot go into recirculation operation. Air is released from the A/C outlets at "Hi Blower" speed and some cold, dry air is also blown onto the windshield (see Figure 13-152).

As the incar temperature begins to lower, the programmer moves out of the maximum A/C position.

When the outlet air temperature reaches a moderate temperature, the system goes into "Bi-Level" operation. Conditioned air flows from both the heater and A/C outlets. Also, a small amount of moderate, dry air is distributed from the defroster outlets.

When maximum heating is required from the system, air is distributed from the heater outlets at "Hi Blower" speed. Some hot, dry air is also blown onto the windshield (see Figure 13-156).

HI Position

The passenger compartment air is recirculated through the A/C system when maximum cooling is required. Cold air is distributed from the A/C outlets at "Hi Blower" speed and a small amount of cold, dry air is also blown onto the windshield (see Figure 13-147).

As the programmer moves from the maximum A/C position, air is drawn in from outside the car to be conditioned. This air is distributed from the A/C and defroster outlets at "Hi Blower" speed.

As the outlet air reaches moderate temperature, the system begins to operate in the "Bi-Level" mode. Some cool, dry air is also released from the defroster outlets (see Figure 13-150).

When the system goes into heater operation, the warm air is released from the heater outlets at "Hi Blower" speed. Some warm, dry air is also released from the defroster outlets.

DEFOG Position

If maximum cooling is required, the outside air door is closed for recirculation operation and the blower is operating at "Hi Blower" speed. Cold, dry air is distributed from the heater, A/C, and defroster outlets, resulting in "Tri-Level" operation (see Figure 13-161).

When maximum cooling is no longer required, the outside air door opens and the blower speed decreases (see Figures

13-159 and 13-160). Complete blower programming is used in the "De-Fog" position. When heating is required from the system, the blower speed increases and reaches "Hi Blower" speed at maximum heating (see Figure 13-157).

DEICE Position

With the selector lever in the "De-Ice" position, the outside air door is closed when maximum cooling is required. All of the air is directed onto the windshield from the defroster outlets at "Hi Blower" speed (see Figure 13-166). When maximum cooling is no longer required, the outside air door opens but the fan remains on "Hi Blower" speed.

Amplifier Theory of Operation

The purpose of the three-stage amplifier used in the Automatic Climate Control system is to amplify the DC signals that are created due to resistance changes in either the temperature dial, the incar sensor, or the ambient sensor (see Figure 13-182). The feedback potentiometer, temperature dial, incar sensor, ambient sensor and R12 form a voltage divider circuit that results in a voltage at the base of Q1. Also, at Q1 in the emitter circuit, R13, R15, and D1 form a voltage divider, resulting in a fixed voltage on the emitter of Q1. During stable operation of the A.C.C. system, the voltage difference between the base and the emitter remains constant that causes Q1 to conduct a constant amount of current (electron flow).

This current flow in Q1 actually flows from ground, through the E-B diode of Q3, through the E-B diode of Q2, and through Q1. This current flow forward biases Q2 and Q3, the Darlington amplifier, and causes it to conduct. This results in current flow through the transducer. This constant current through the transducer produces a constant vacuum output from the transducer.

If the resistance of a sensor increases as the result of a temperature decrease, or if the temperature setting on the temperature dial is increased, a larger voltage will be present at the base of Q1. This reduces the current flow through Q1, which in turn reduces the conduction of the Darlington amplifier through the transducer. Low transducer current produces high vacuum at the transducer vacuum output. The vacuum motor moves in the direction of "more heat". The feedback potentiometer is mechanically connected to the vacuum motor mechanism. As the vacuum motor moves to the "increased heat" position, the feedback "pot" reduces in resistance. This movement yields a cancelling effect to the increased resistance which caused the movement. When the feedback "pot" completely offsets the increase, the voltage at the base of Q1 is the same as it was earlier, as described in the stable operation and the movement stops.

If the temperature at a sensor increases or the temperature dial is moved to a lower temperature setting, the voltage at the base of Q1 will decrease. More current will now conduct through Q1, Q2, and Q3. The increased current

flow through Q1 causes Q2 and Q3 to conduct more current through the transducer. The vacuum at the transducer output will now decrease, causing the vacuum motor to move in the direction of more cooling. As the vacuum motor moves, the feedback "pot" increases in resistance, offsetting the original resistance decrease. The amplifier has now stabilized again and the movement stops.

The .1 Mfd. capacitor at the base of Q1 filters out any high-frequency AC signals from entering the DC amplifier. AC signals result in erratic operation of the A.C.C. system. The 2 Mfd. capacitor controls the reaction time of the amplifier and helps to stabilize its operation. This eliminates any oscillations in the system's operation. R25 is a feedback resistor that reduces the gain of the DC amplifier and results in more stable operation of the system.

Diode D1 is physically located under the Darlington amplifier. When the Darlington heats up, it tries to conduct more current. D1 also heats up and reduces in resistance. This lowers the emitter voltage of Q1 and reduces its conduction. This results in lower conduction of the Darlington amplifier, thereby bringing it back to its original conduction level.

Diode D2 is a spike suppression diode. This prevents any voltage spikes from the input supply line from entering the amplifier.

DIVISION III

ADJUSTMENTS AND MINOR SERVICE

13-73 ADJUSTMENT OF AUTOMATIC CLIMATE CONTROL PROGRAMMER, LINK ASSEMBLY, AND TEMPERATURE DOOR

1. Install programmer to case.
2. Place the link over the programmer shaft and secure it to the mix door arm with retainer (clip). See Figure 13-186.
3. Preload the air mix door in the MAX "HEAT" position with a force on the door equal to 3 lb.in. torque at the mix door arm. An equivalent of this is the force of air at HI blower which can be induced by HI blower. See Figure 13-186.
4. Apply vacuum to programmer port number 2 and 3. Connect a vacuum gage to port number 4. Seal all other ports. The programmer will index to MAX "HEAT". See Figure 13-186.
5. Tighten the link screw 15-20 lb.in. to secure the adjustment.

NOTE: *Do this carefully to avoid influencing the programmer, link, or door positions.*

6. Release the preload on the air mix door.
7. Connect positive 12 volts to Terminal 2.
8. Connect Terminal 1 to ground and Terminal 3 to MAX A/C.
9. Check for vacuum output on port 4 and seal of the mix door against the frame. See Figure 13-186.
10. Install vacuum and electrical connections.

13-74 TEMPERATURE DIAL CALIBRATION

NOTE: *Be sure to allow sufficient time for car engine to warm up and A.C.C. system to turn-on before attempting calibration.*

1. Connect A.C.C. Tester J-23678 into the A.C.C. wiring harness and the programmer.
2. Place control panel selector lever in "VENT".
3. Place manual-automatic switch on the tester in the manual position.
4. Place the temperature dial calibrator switch on the tester in the "CAL" position.
5. Note the voltmeter reading on tester.
6. Press "Compare" button and note voltmeter reading.
7. With the "Compare" button pressed in, rotate the temperature dial on the control panel until the voltmeter reading is the same as it was in Step 5 (button not pressed in).
8. The control panel temperature dial should be set at the temperature dial setting on the tester panel ("75"). If it does not, use Tool J-21530 to hold the gear on the left side of the temperature dial and slip the dial to the correct setting. If the temperature dial cannot be calibrated using this procedure, it is defective.

DIVISION IV

REMOVAL AND INSTALLATION

13-75 REMOVAL AND INSTALLATION OF DASH CONTROL ASSEMBLY

a. Removal

1. Disconnect battery.
2. Unscrew headlight escutcheon and remove headlight switch.
3. Remove lower dash trim.

4. Remove two (2) see-lights from trim plate.
5. Remove four (4) screws from control face.
6. Remove one (1) screw from under dash which connects heater control to instrument panel forward support.
7. Disconnect vacuum and electrical connectors.
8. Remove control assembly.

b. Installation

1. Install control assembly reverse of removal procedure.

13-76 REMOVAL AND INSTALLATION OF BLOWER MOTOR AND AIR INLET ASSEMBLY

a. Removal

1. Support hood and loosen hood hinge from extension.
2. Remove extension and plate assembly.
3. (Blower Motor Only) Disconnect blower motor wire. Remove screws securing blower motor to air inlet assembly.

(Blower Motor and Air Inlet Assembly) Disconnect blower motor wire. Remove four (4) nuts and two (2) screws securing blower and air inlet assembly to dash.

Installation

1. Install blower motor or blower motor and air inlet assembly reverse of removal procedures and seal along mating surfaces between dash and air inlet assembly.

13-77 REMOVAL AND INSTALLATION OF HEATER ASSEMBLY OR HEATER CORE

a. Removal

1. Drain radiator and disconnect heater inlet and outlet hoses at dash.
2. Disconnect control wires from defroster door and vacuum hose diverter door actuator diaphragm and control cable from temperature door lever.
3. Remove four (4) nuts securing heater assembly to dash.
4. Remove screw securing defroster outlet tab to heater assembly.
5. Work heater assembly rearward until studs clear dash and remove heater assembly.

b. Installation

Install heater assembly reverse of removal procedures and

seal along mating surfaces between dash and heater assembly.

13-78 REMOVAL AND INSTALLATION OF IN-CAR SENSOR

a. Removal

1. Open glove box door.
2. Reach up through opening in glove box and grasp sensor body and twist 1/4 turn clockwise and pull down through opening.
3. Disconnect wire connector from sensor.
4. Disconnect aspirator hose from sensor.
5. Remove sensor.

b. Installation

To replace, reverse removal procedure, making sure sensor body spacer is in between body and sensor grille.

13-79 REMOVAL AND INSTALLATION OF PROGRAMMER

a. Removal

1. Remove glove box.
2. Loosen adjustment screw on link assembly.
3. Remove vacuum and electrical connections.
4. Remove three (3) screws from programmer and remove programmer.

b. Installation

1. To replace, install programmer onto the heater defroster assembly.
2. Preload the air mix door in the MAX "HEAT" position with a force on the door equal to 3 lb.in. torque at the mix door arm. This is equivalent to this force of air on the door on "DEICE" setting with HI blower.
3. Apply vacuum to programmer Ports 2 and 3. Connect a vacuum gage to Port 4. Seal all other ports. The programmer will index to MAX "HEAT".
4. Tighten the link screw 15-20 lb.in. to secure the adjustment. Do this carefully to avoid influencing the programmer, link, or door positions. This completes the adjustment procedure.
5. Release the preload on the air mix door. Connect positive 12 VDC to Terminal 2. Connect Terminal 1 to ground and Terminal 3 to ground through a 68 ohm resistor. The

programmer will index to MAX "A/C". Check for vacuum output on Port 4 and seal of the mix door against the frame. Repeat the adjustment, if necessary.

6. Install vacuum and electrical connections.

13-80 REMOVAL AND INSTALLATION OF PROGRAMMER COMPONENTS

Vacuum Valve

1. Identify vacuum hoses connected to the two outboard side ports of the vacuum valve and the port to which each is connected. Disconnect the two vacuum hoses.
2. Disconnect vacuum hose to center port on valve at the transducer.
3. Remove two vacuum valve retaining studs and remove valve. Lift valve drive arm off of vacuum motor mechanism boss when removing valve.
4. To replace, reverse removal procedure. Make certain vacuum valve spring is in place. Refer to Figure 13-125.

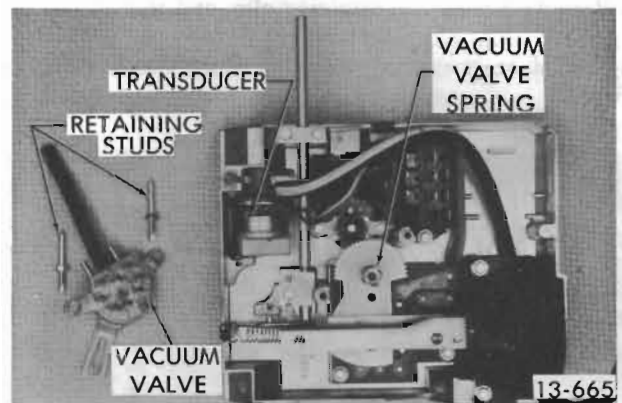

Figure 13-125 Vacuum Valve - Removed

Checking Relay

1. Disconnect two (2) vacuum hoses from vacuum valve at the relay. Identify hoses and relay ports to which they connect for reconnecting.
2. Disconnect long vacuum hose at other side of relay and short vacuum hose at the vacuum motor and remove relay.
3. To replace, reverse removal procedure. See Figure 13-126.

NOTE: If long vacuum hose (from checking relay to transducer) is replaced, the replacement hose must be at least 15" in length.

Transducer

1. Disconnect two vacuum hoses at transducer; identify hoses and ports for reconnection.

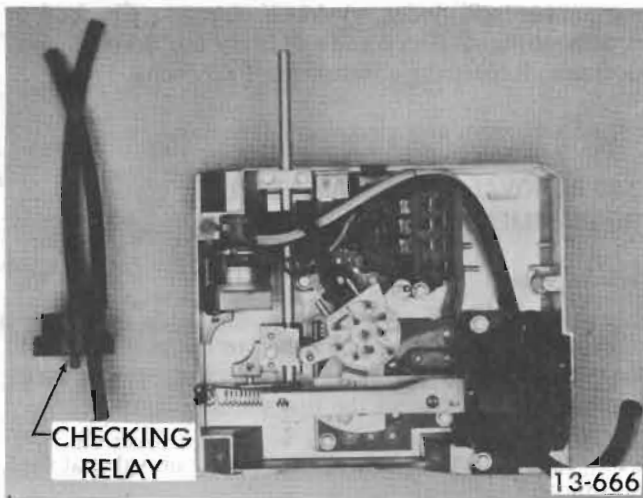

Figure 13-126 Checking Relay - Removed

2. Disconnect and identify two (2) electrical terminals to transducer.
3. Remove hex screw, retaining clip, and transducer.
4. To replace, reverse removal procedure. Refer to Figure 13-127.

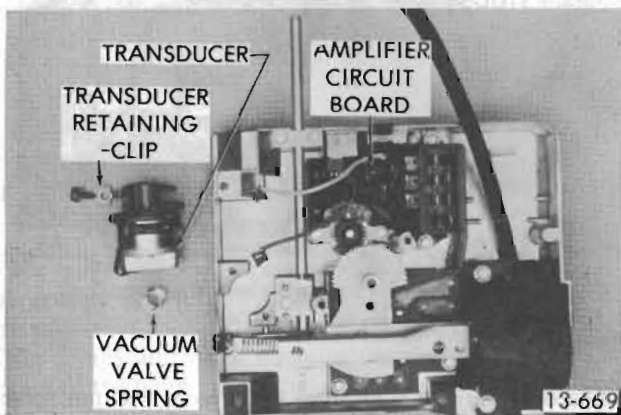

Figure 13-127 Transducer - Removed

Amplifier Circuit Board

1. Remove vacuum valve.
2. Remove two (2) programmer electrical connector retaining screws and lift connector body from amplifier terminals.
3. Remove amplifier heatsink retainer clip and insulator.
4. Remove two (2) amplifier retaining screws at amplifier feedback potentiometer.
5. Disconnect two (2) wires at transducer. Note which wire connects to each terminal.

6. Remove amplifier circuit board.

7. To replace, reverse removal procedure and calibrate feedback potentiometer. See Figure 13-128.

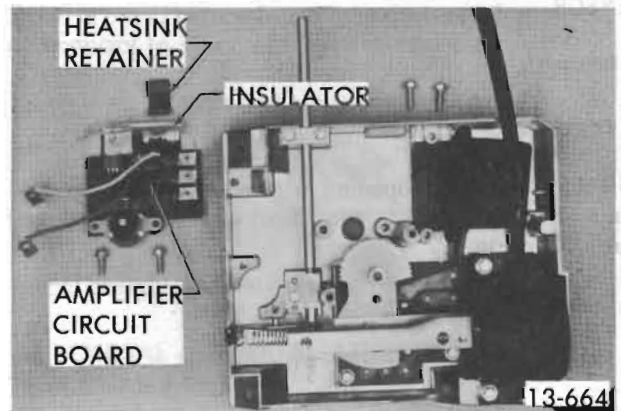

Figure 13-128 Amplifier Circuit Board - Removed

Vacuum Motor

1. Remove vacuum valve retaining studs and lift vacuum valve to remove drive arm from boss on vacuum motor mechanism.
2. Remove retaining clip and power spring from motor mechanism.
3. Disconnect vacuum hose from port on motor.
4. Remove two (2) motor retaining screws and remove motor, lifting upward.
5. To replace, reverse removal procedure. See Figure 13-129.

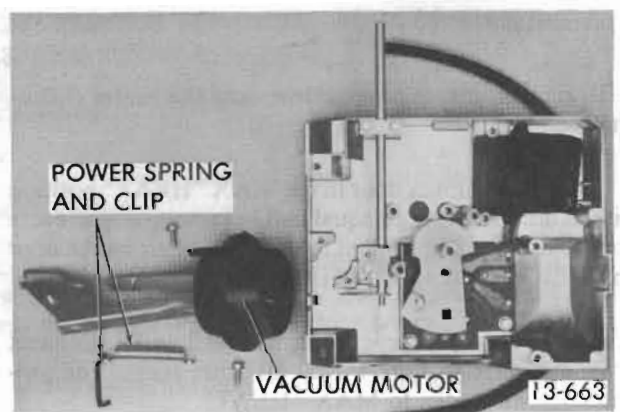

Figure 13-129 Vacuum Motor and Power Spring - Removed

Blower Resistor Wiper ARM ASSEMBLY OR Feedback Pot Arm Assembly

1. Remove vacuum valve and spring.
2. Remove vacuum motor and power spring.

3. Lift blower resistor wiper arm and feedback pot arm off of blower resistor circuit board. Take care to locate single ball bearing, making certain it is located in bearing cup on blower resistor circuit board.

4. Separate blower resistor wiper arm from feedback pot arm. Be sure to locate two (2) single ball bearings and insure their location in bearing cups on wiper arm.

5. To replace, reverse removal procedure. Make sure ball bearings are properly located in bearing cups. See Figure 13-130.

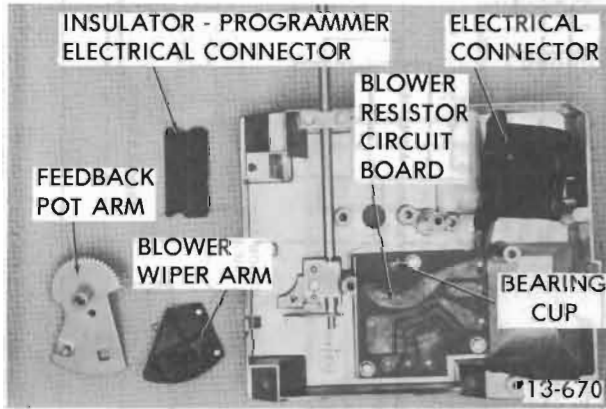

Figure 13-130 Blower Wiper Arm and Feedback Pot Arm - Removed

Mix Door Operating Arm

1. Remove vacuum valve.
2. Remove vacuum motor retaining screws and power spring. Position motor mechanism to disengage mix door operating arm (programmer output shaft).
3. Disconnect electrical terminals and vacuum hoses at transducer. Identify connections for reassembly.
4. Remove three (3) retaining screws and two (2) retaining clips and remove mix door arm.
5. To replace, reverse removal procedure. See Figure 13-131.

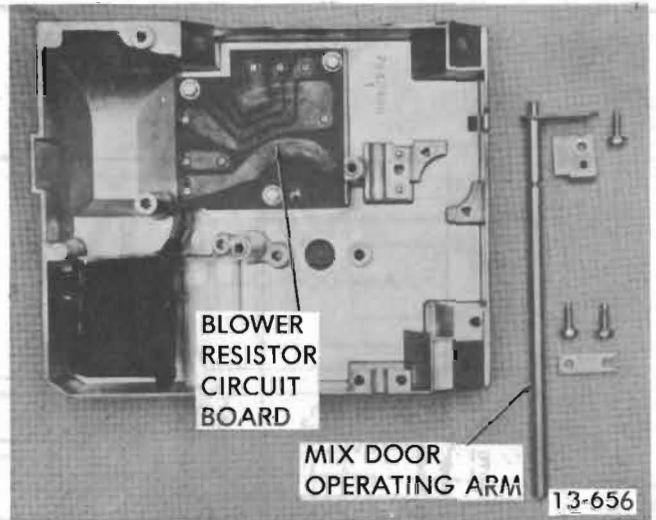

Figure 13-131 Mix Door Operating Arm - Removed

Blower Resistor Circuit Board

1. Remove blower resistor wiper arm assembly using correct procedure.
2. Remove three (3) retaining screws and blower resistor circuit board. Take care that single ball bearing is kept located in bearing cup on circuit board.
3. Remove three (3) electrical terminals from programmer electrical connector body.
4. To replace, reverse removal procedure. See Figure 13-132.

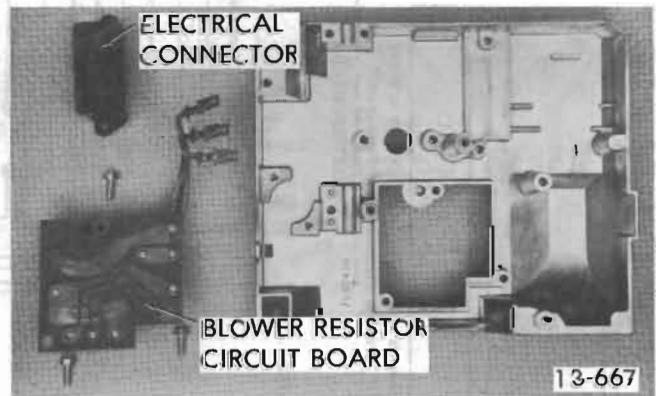

Figure 13-132 Blower Resistor Circuit Board - Removed

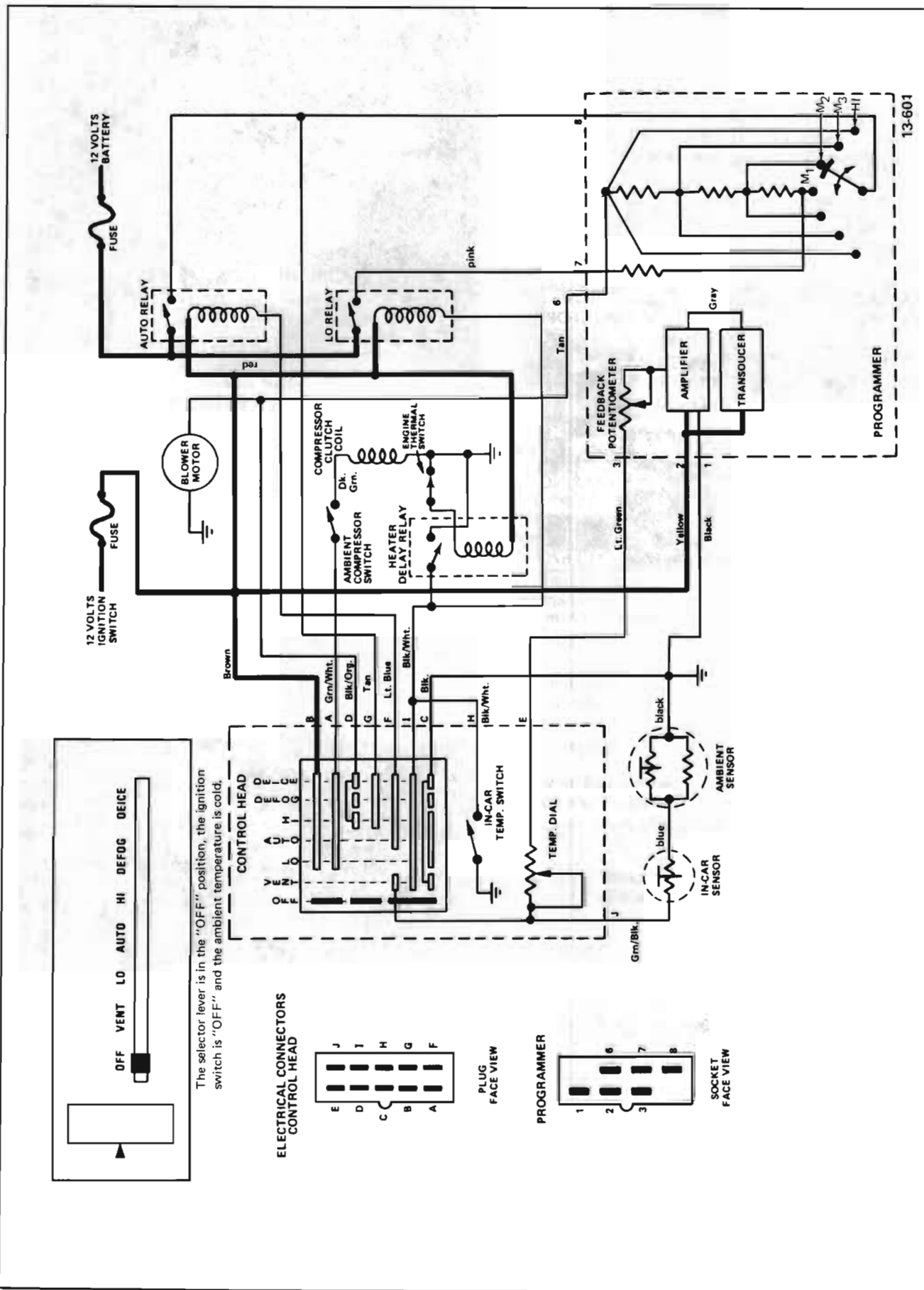

Figure 13-133 45-46-48-49000 Series Electrical Operation - Selector Lever in OFF

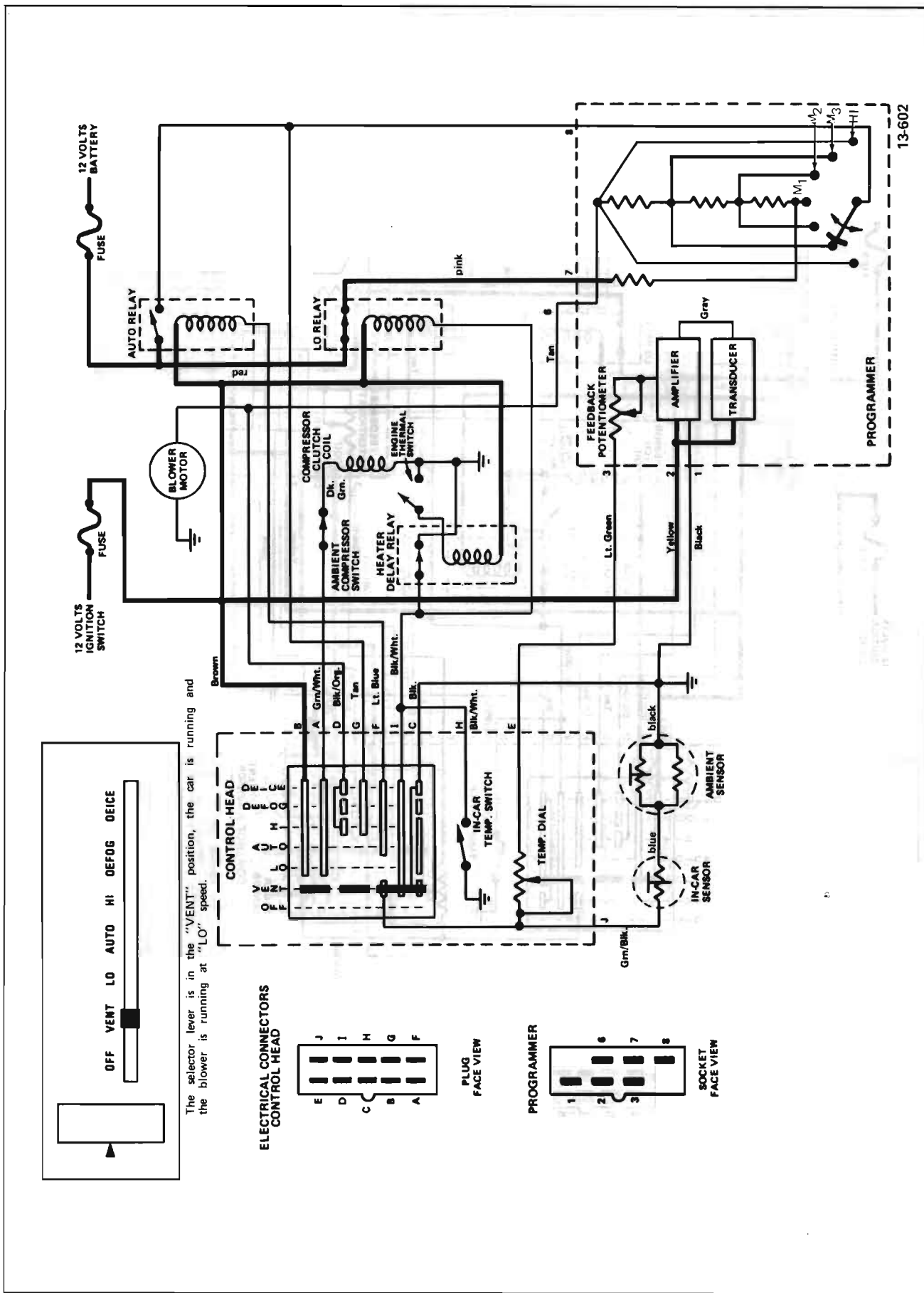

Figure 13-134 45-46-48-49000 Series Electrical Operation - Selector Lever in VENT

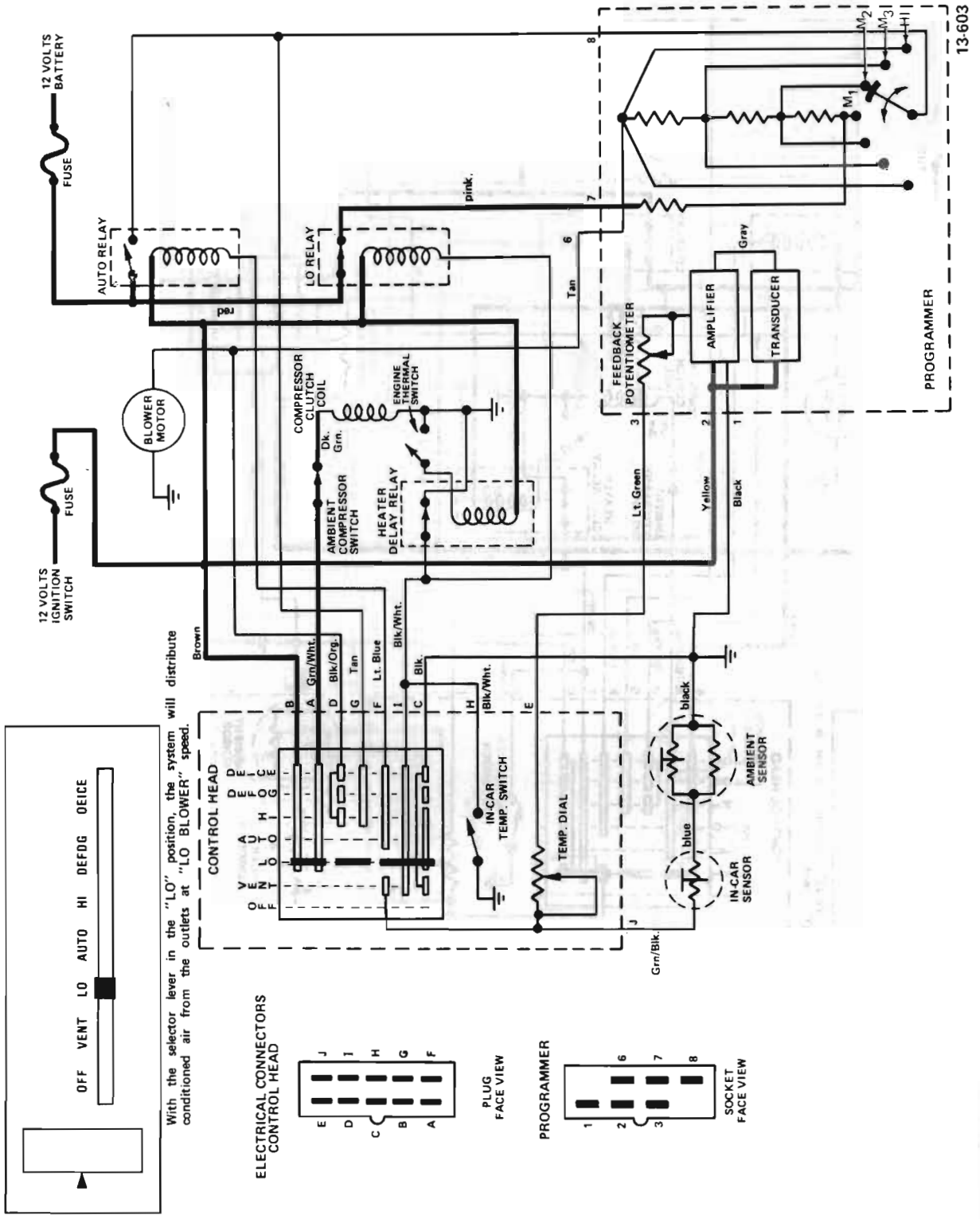

Figure 13-135 45-46-48-49000 Series Electrical Operation - Selector Lever in LO

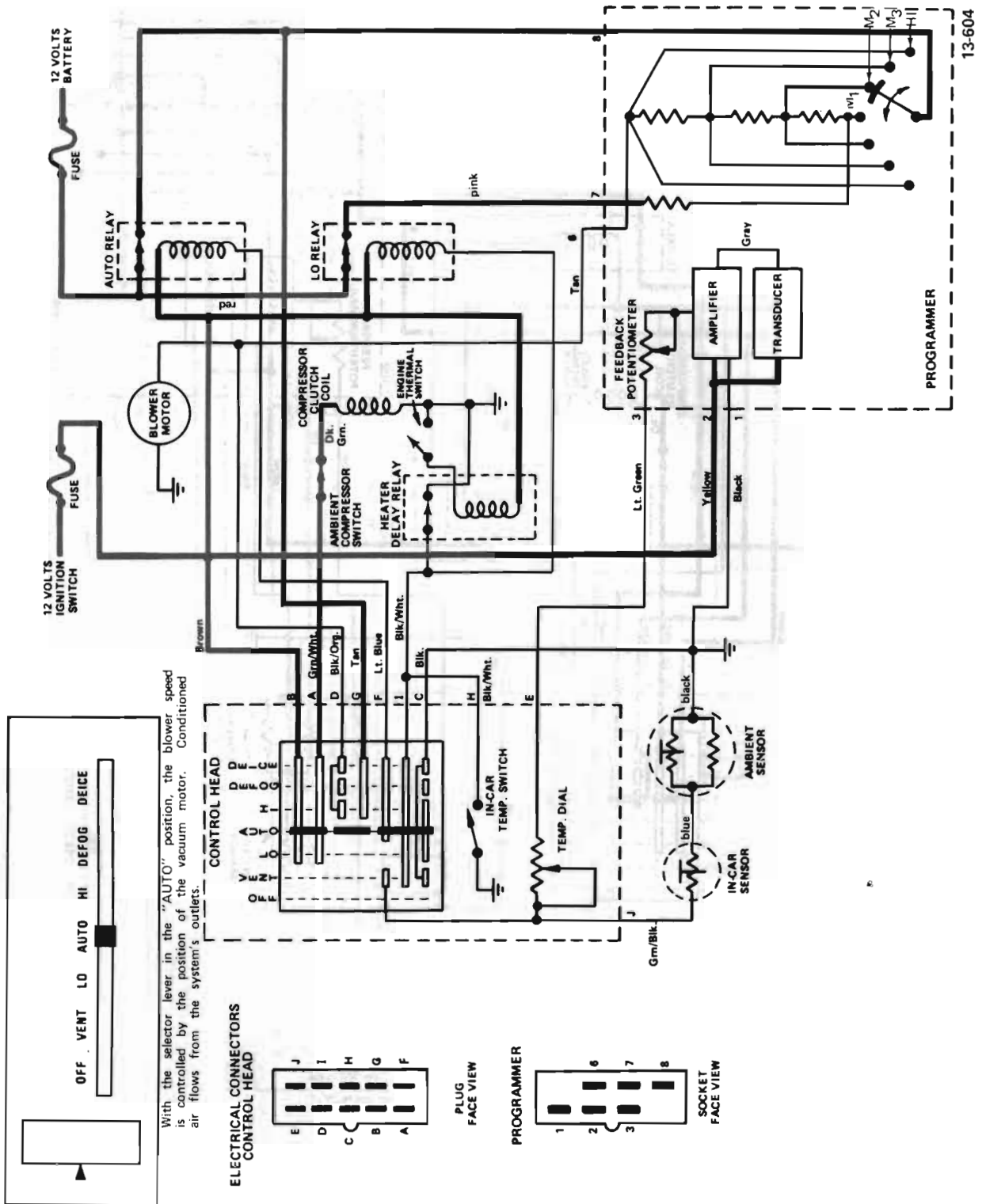

Figure 13-136 45-46-48-49000 Series Electrical Operation - Selector Lever in AUTO

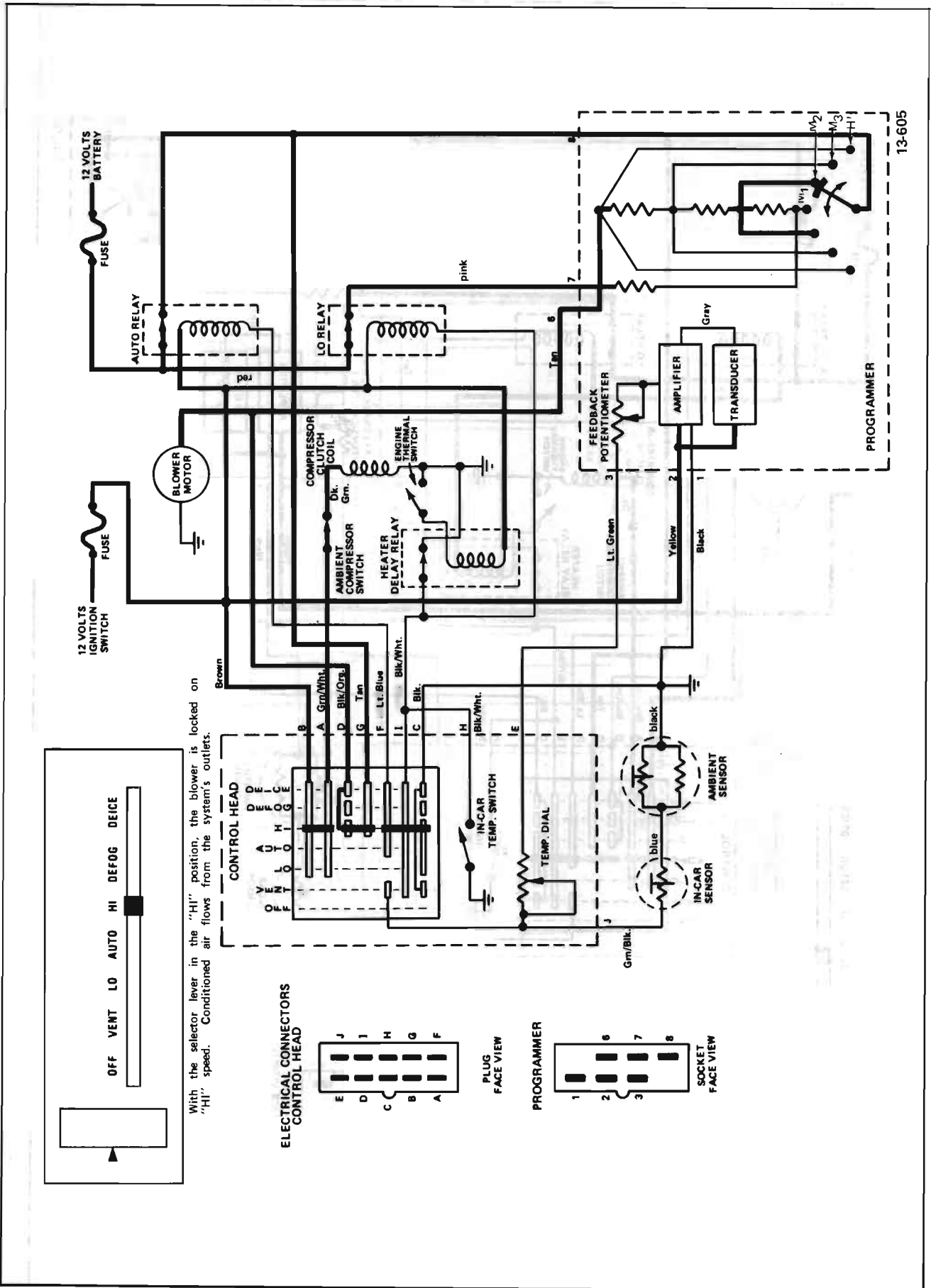

Figure 13-137 45-46-48-49000 Series Electrical Operation - Selector Lever in HI

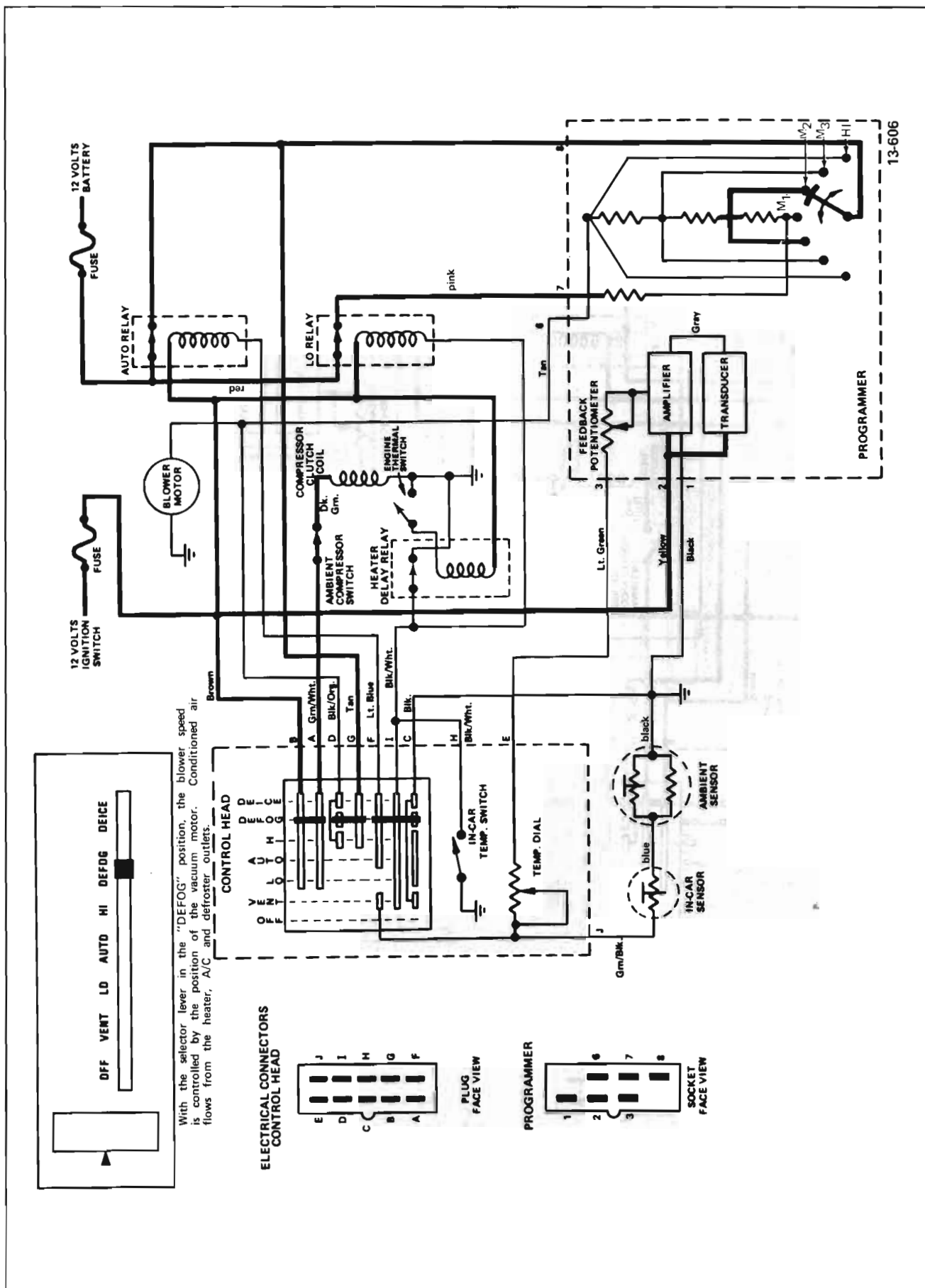

Figure 13-138 45-46-48-49000 Series Electrical Operation - Selector Lever in DEFOG

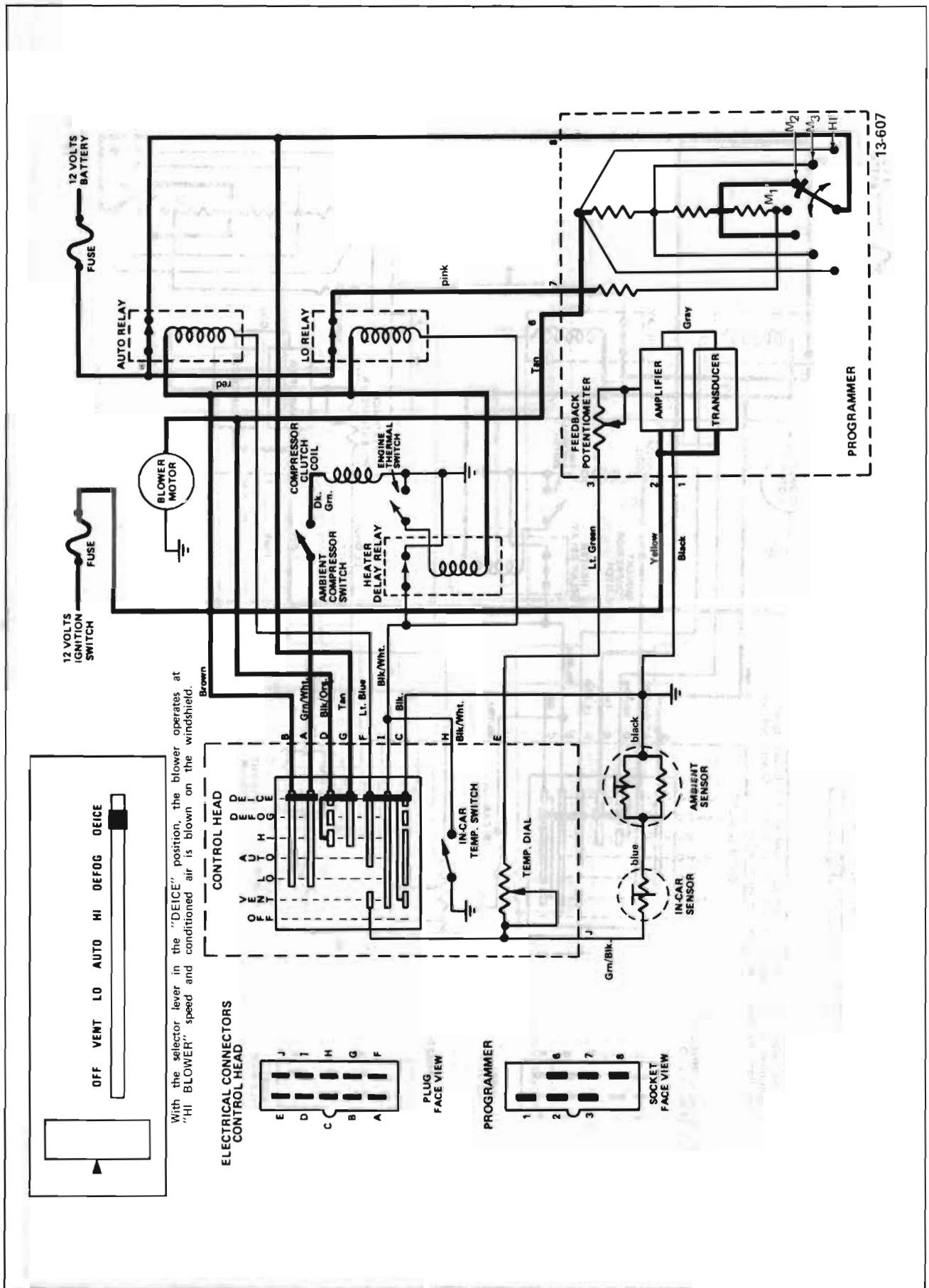
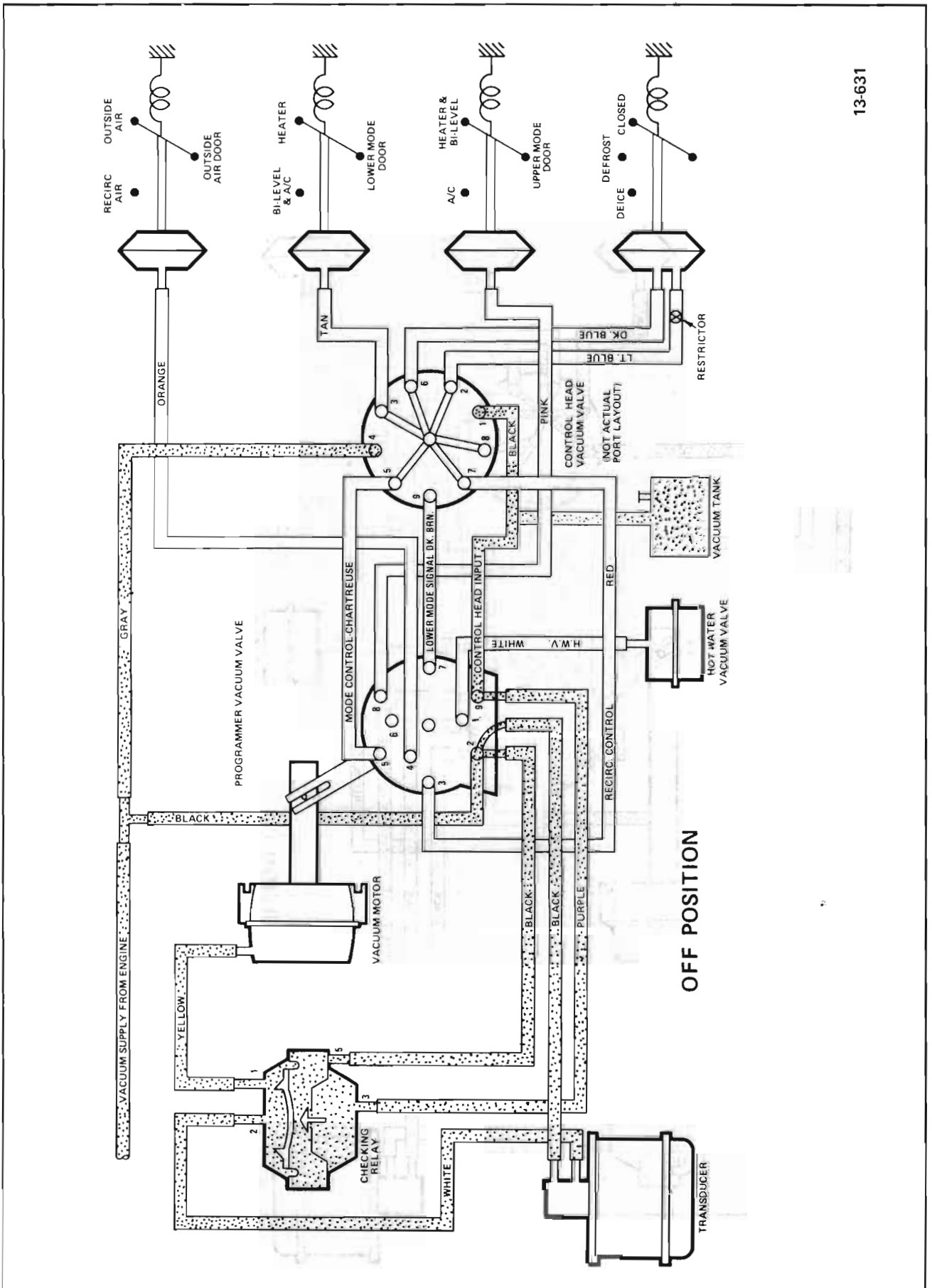
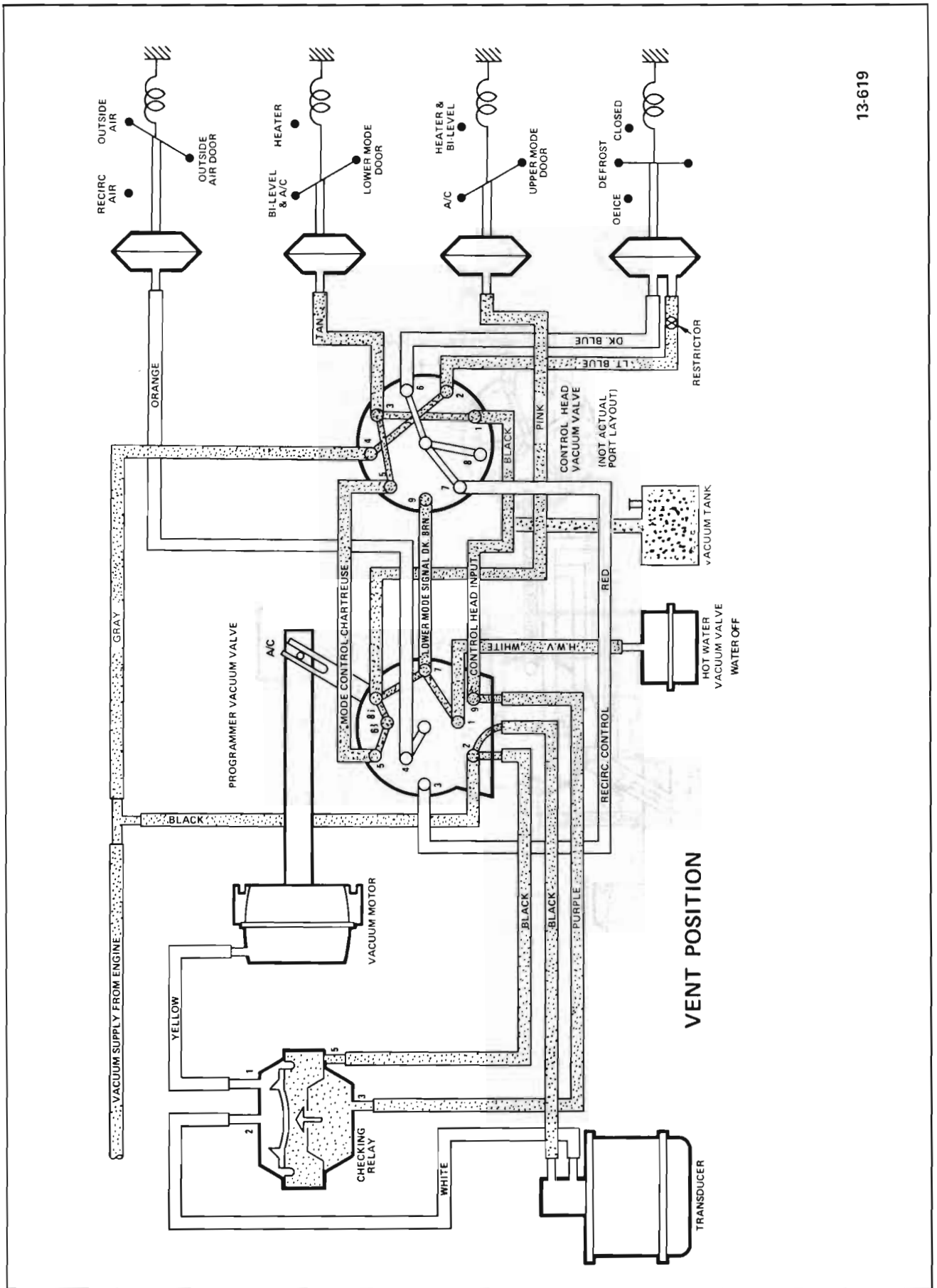

Figure 13-139 45-46-48-49000 Series Electrical Operation - Selector Lever in DEICE



13-631

Figure 13-140 45-46-48-49000 Series Vacuum Circuits - OFF Position



13-619

Figure 13-141 45-46-48-49000 Series Vacuum Circuits - System in VENT Position

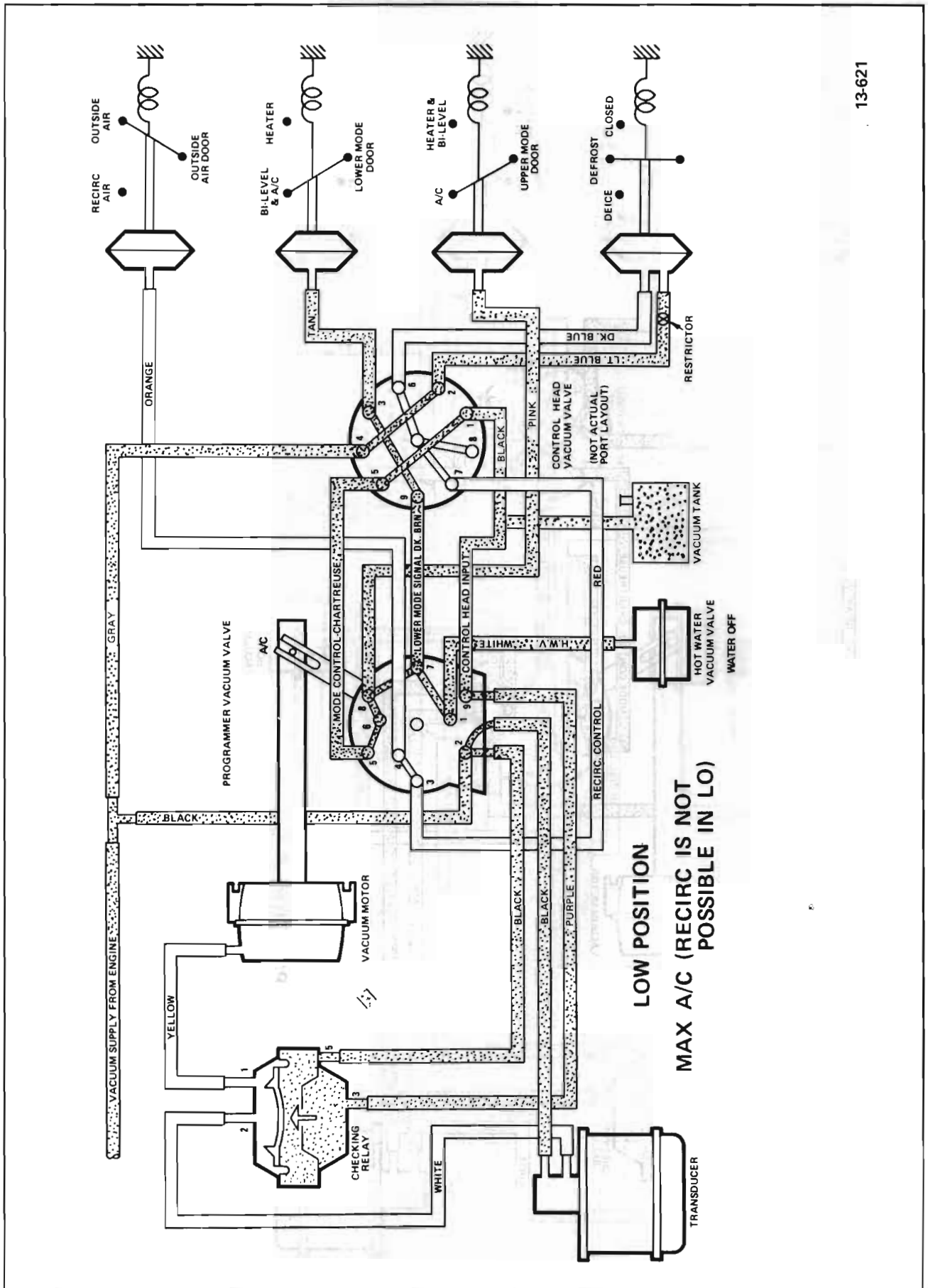
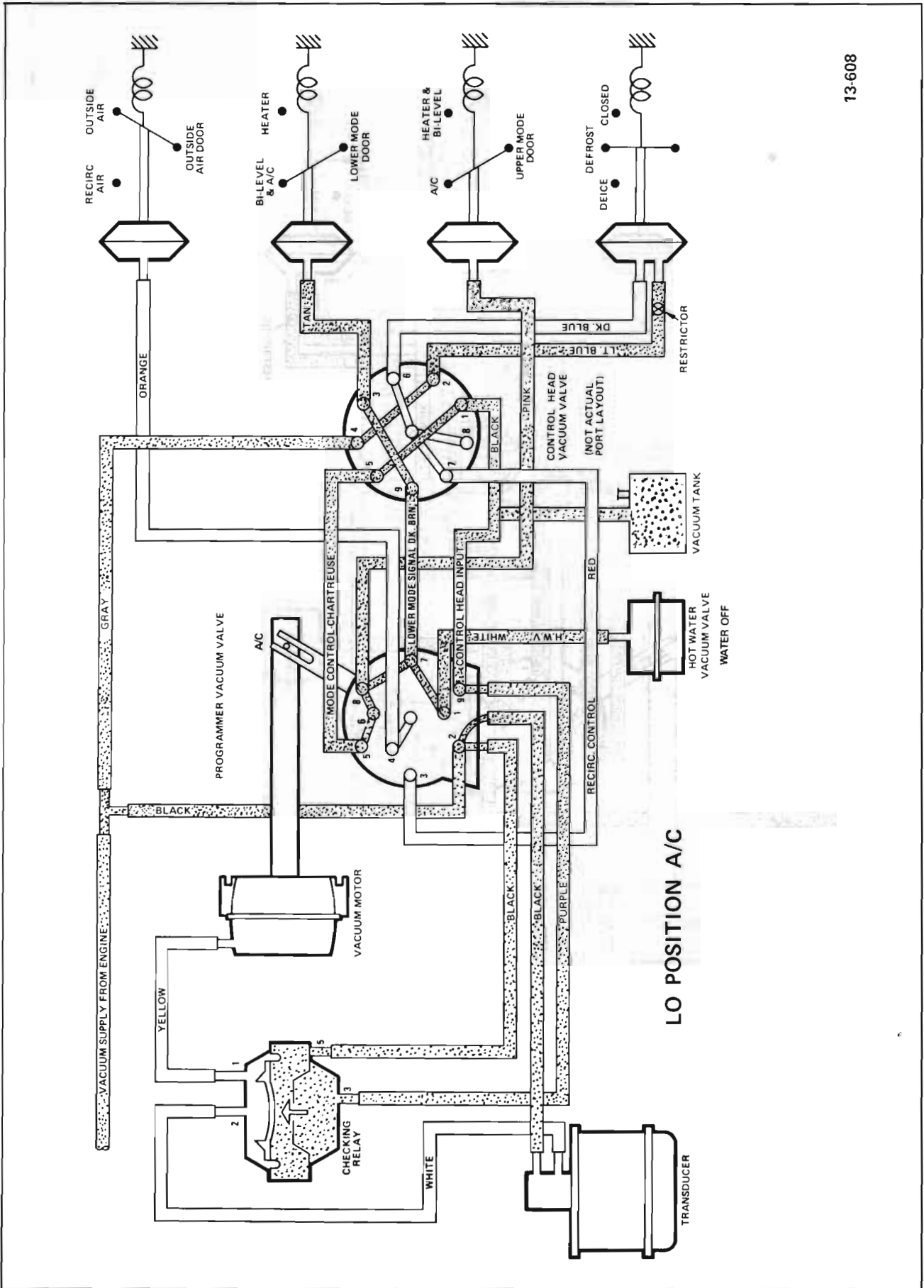
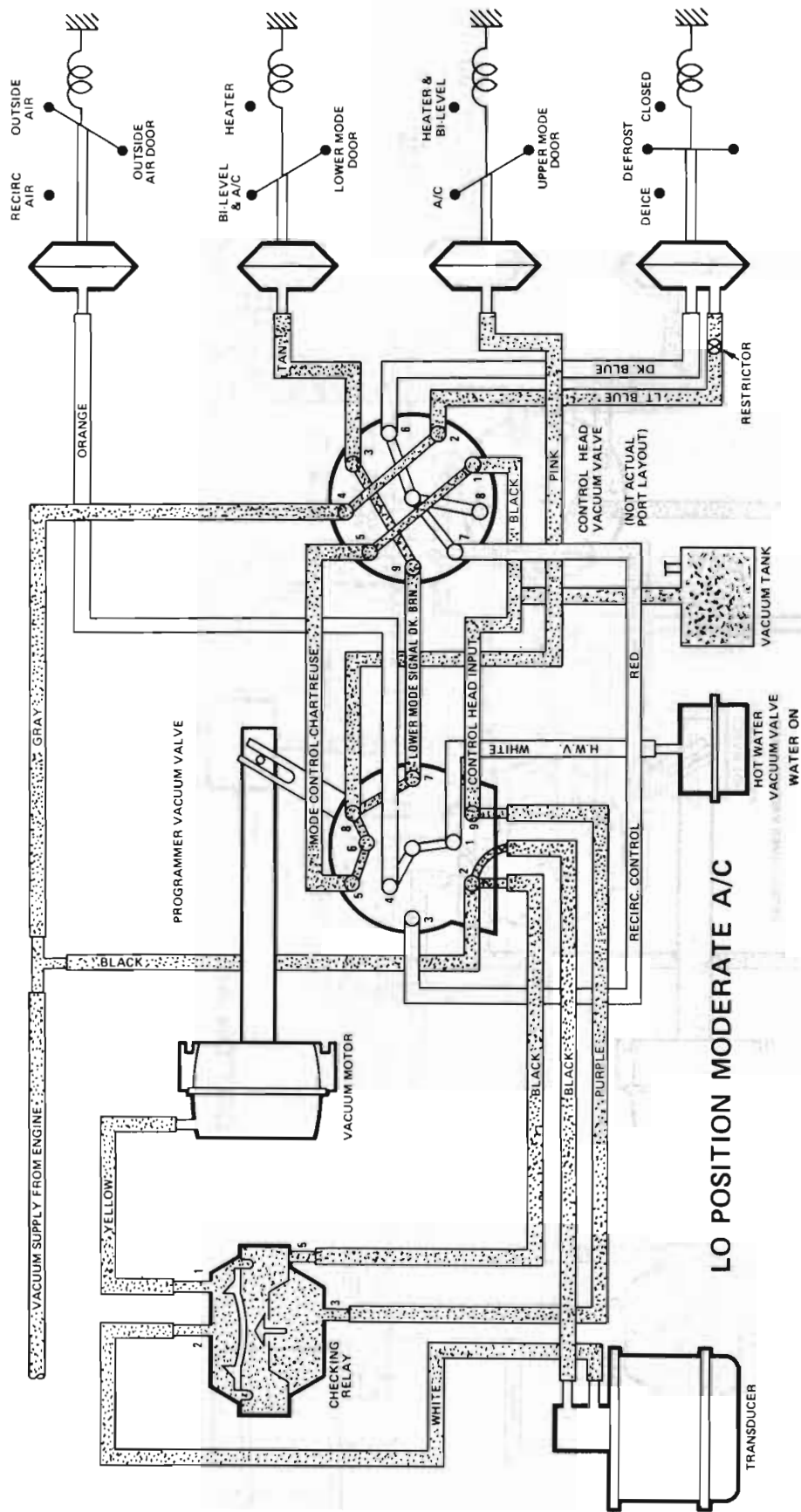

Figure 13-142 45-46-48-49000 Series Vacuum Circuits - System in MAX A/C LO Position (Recirc Impossible in LO)



13-608

Figure 13-143 45-46-48-49000 Series Vacuum Circuits - System in LO Position A/C



13-609

Figure 13-144 45-46-48-49000 Series Vacuum Circuits - System in LO Position Moderate A/C

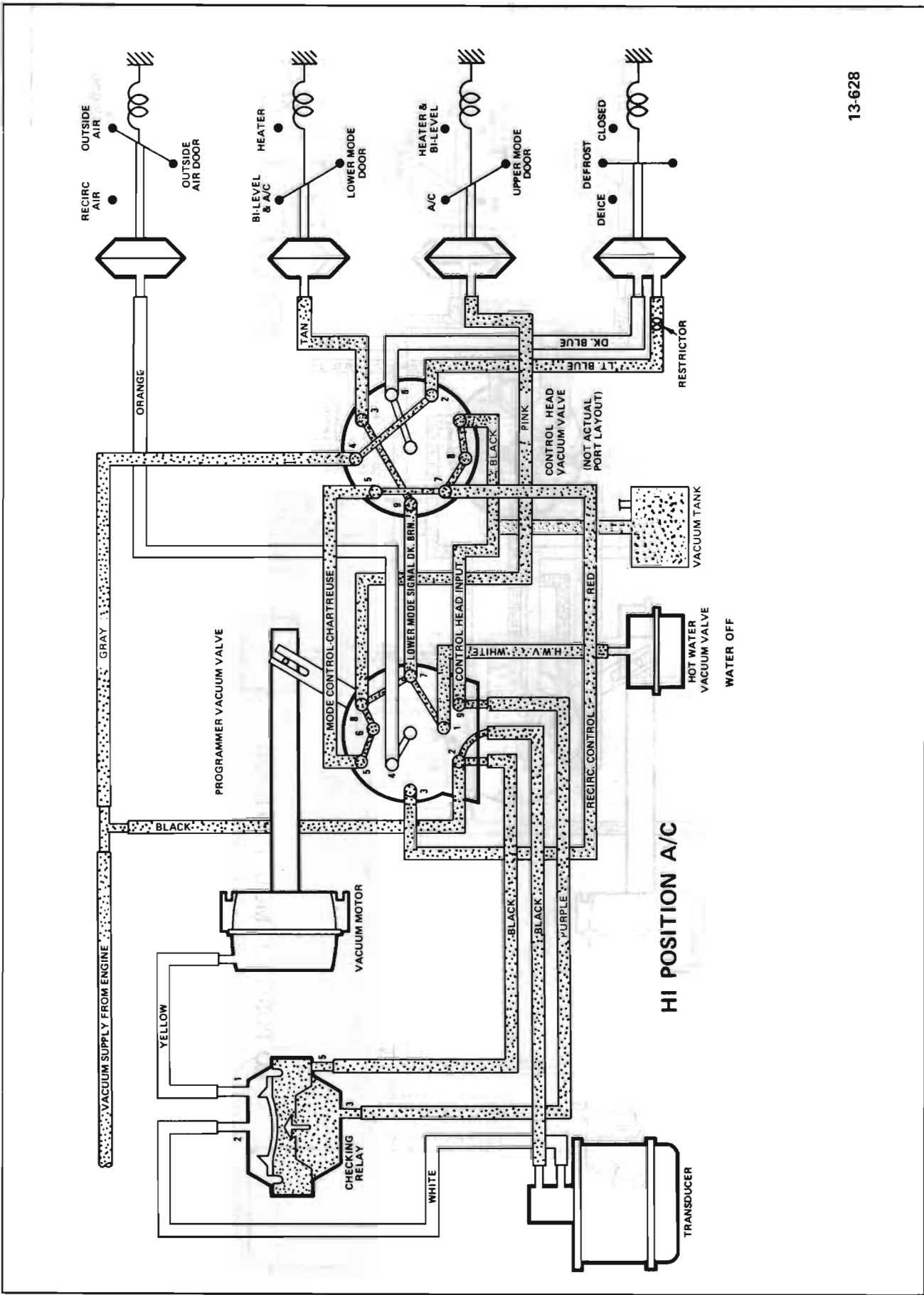

13-628

Figure 13-145 45-46-48-49000 Series Vacuum Circuits - System in HI Position A/C

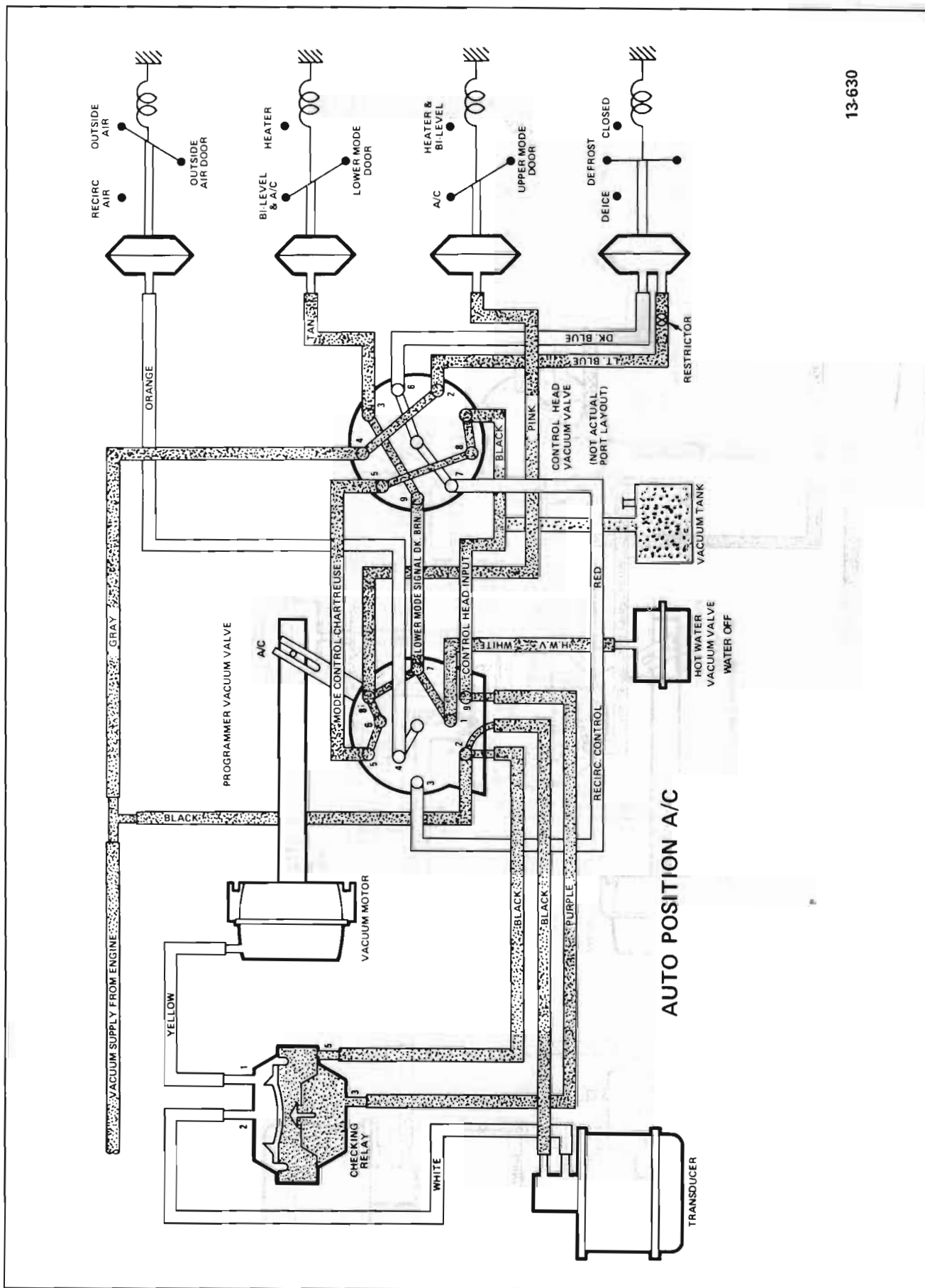

13-630

Figure 13-146 45-46-48-49000 Series Vacuum Circuits - AUTO Position A/C

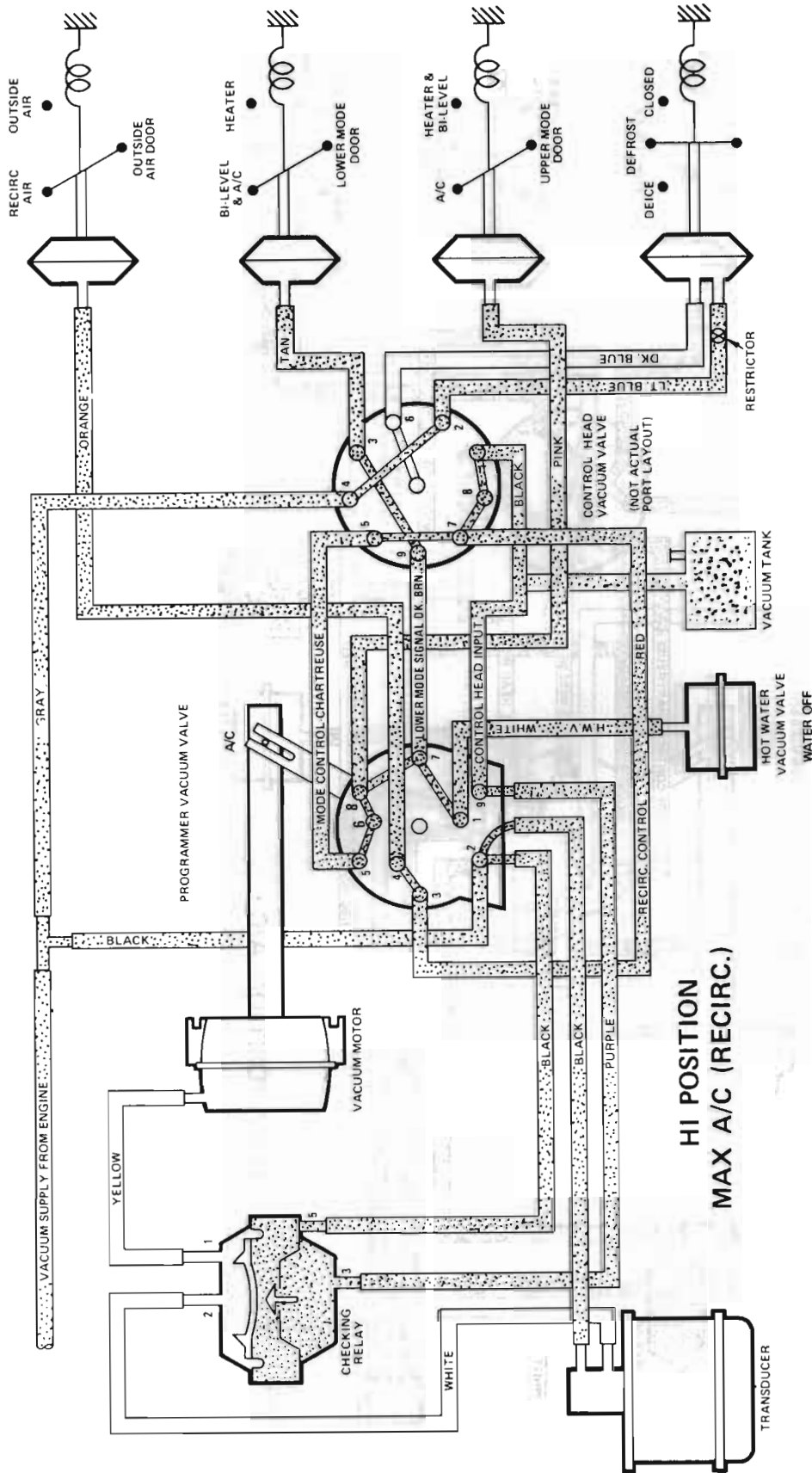
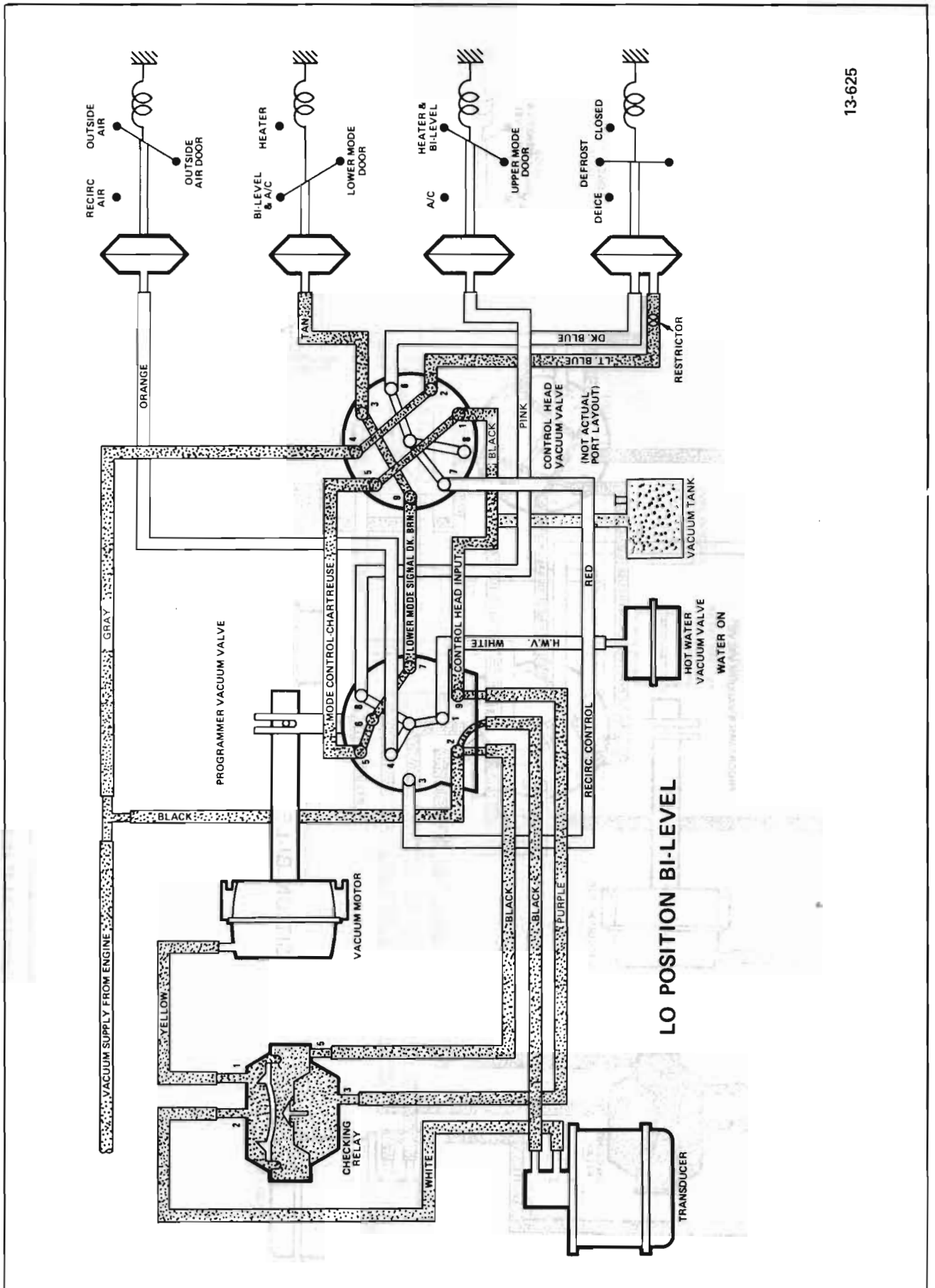

Figure 13-147-45-46-48-49000 Series Vacuum Circuits - System in HI Position MAX A/C (Recirc)



13-625

Figure 13-148 45-46-48-49000 Series Vacuum Circuits - System in LO Position Bi-Level

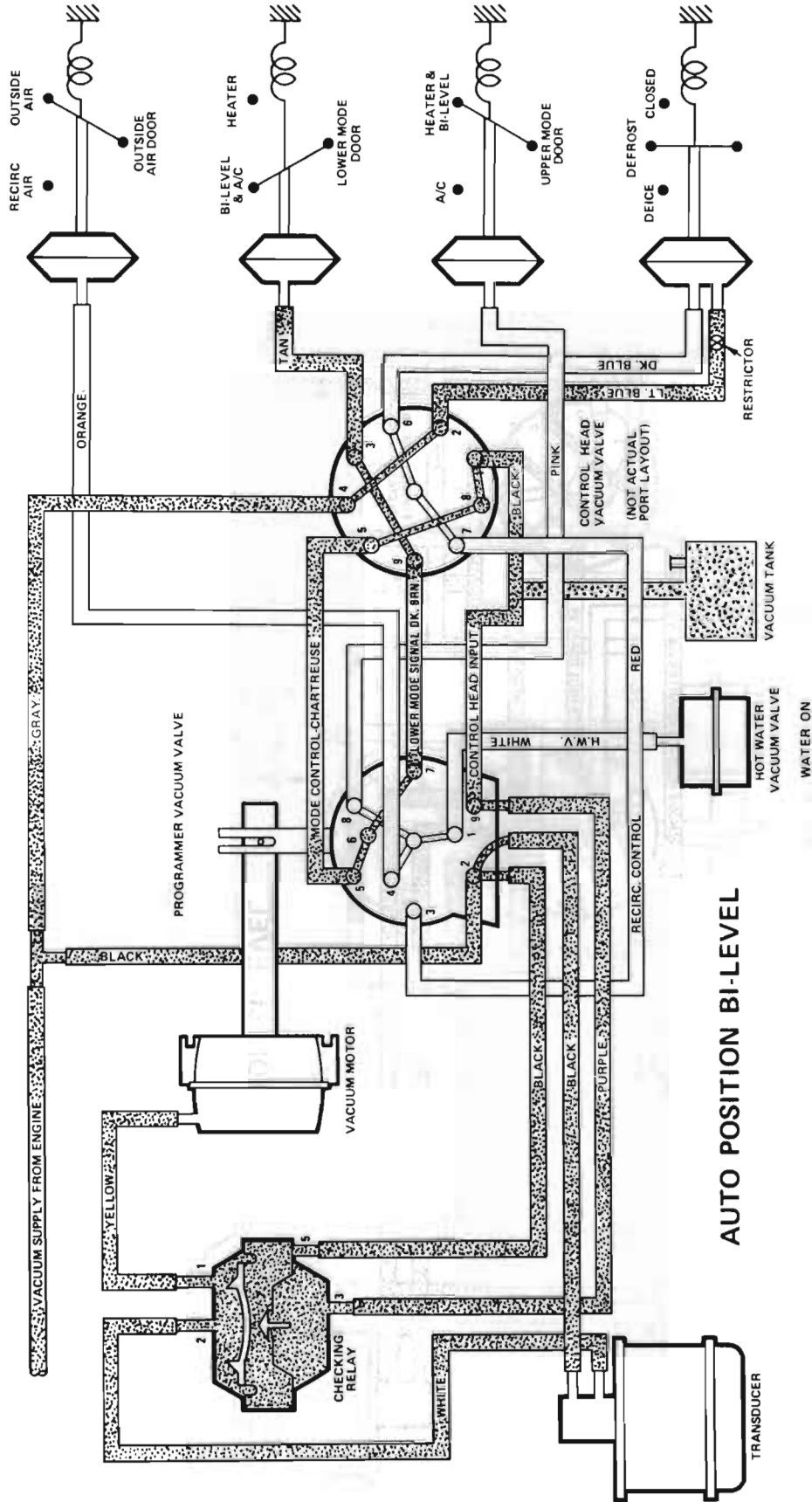
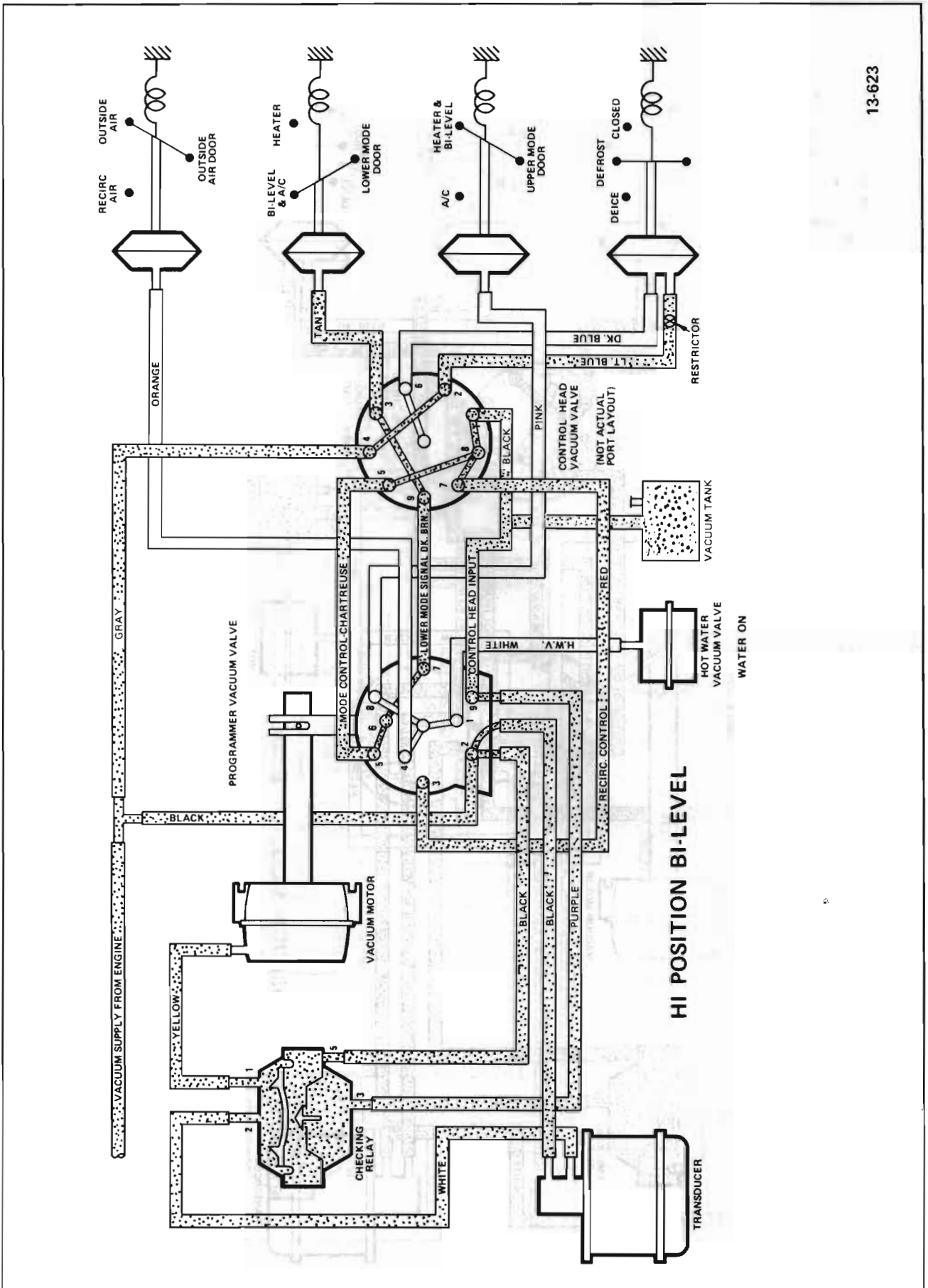
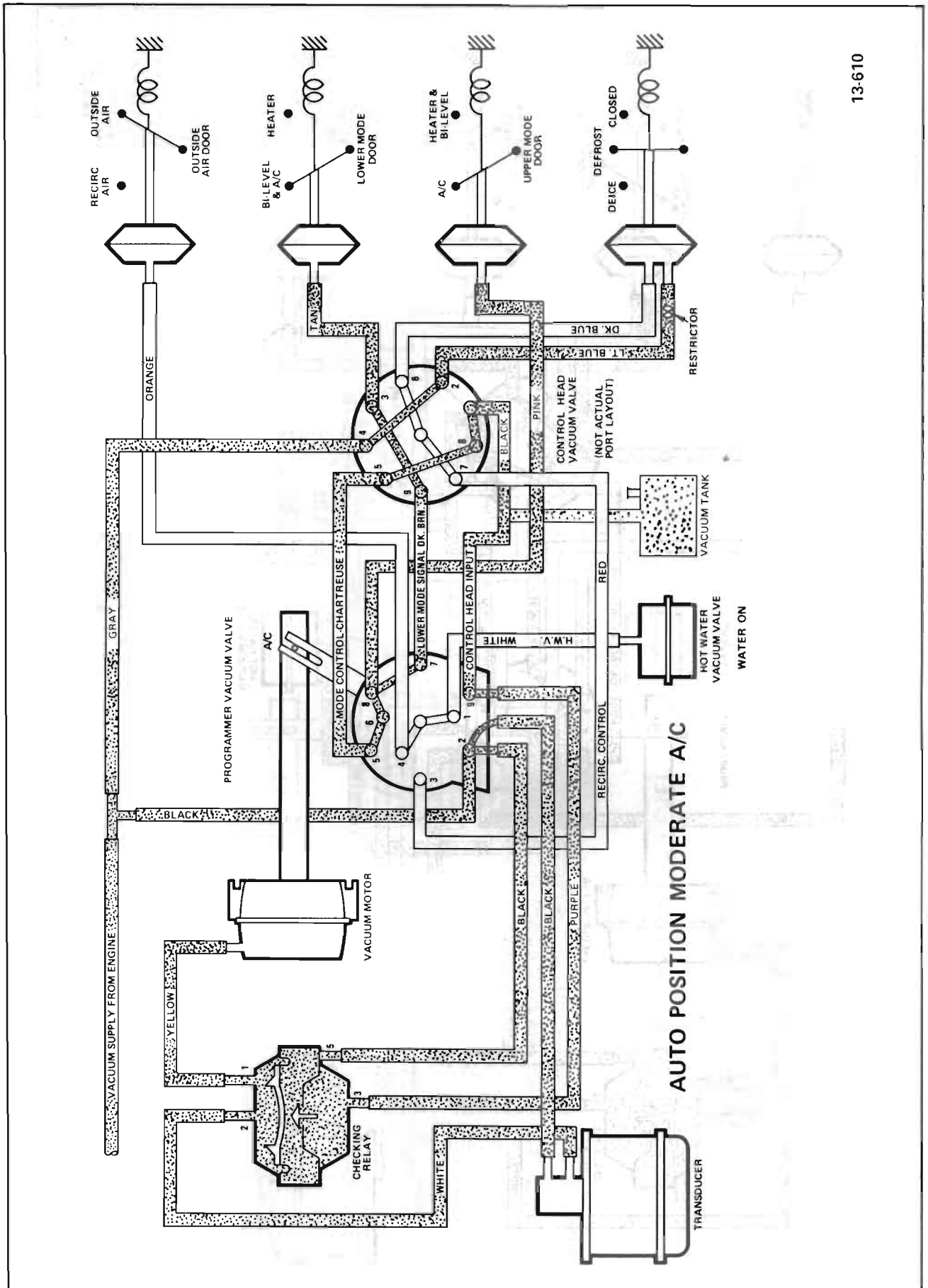

Figure 13-149 45-46-48-49000 Series Vacuum Circuits - System in AUTO Position Bi-Level



13-623

Figure 13-150 45-46-48-49000 Series Vacuum Circuits - System in HI Position Bi-Level



13-610

Figure 13-151 45-46-48-49000 Series Vacuum Circuits - System in AUTO Position Moderate A/C

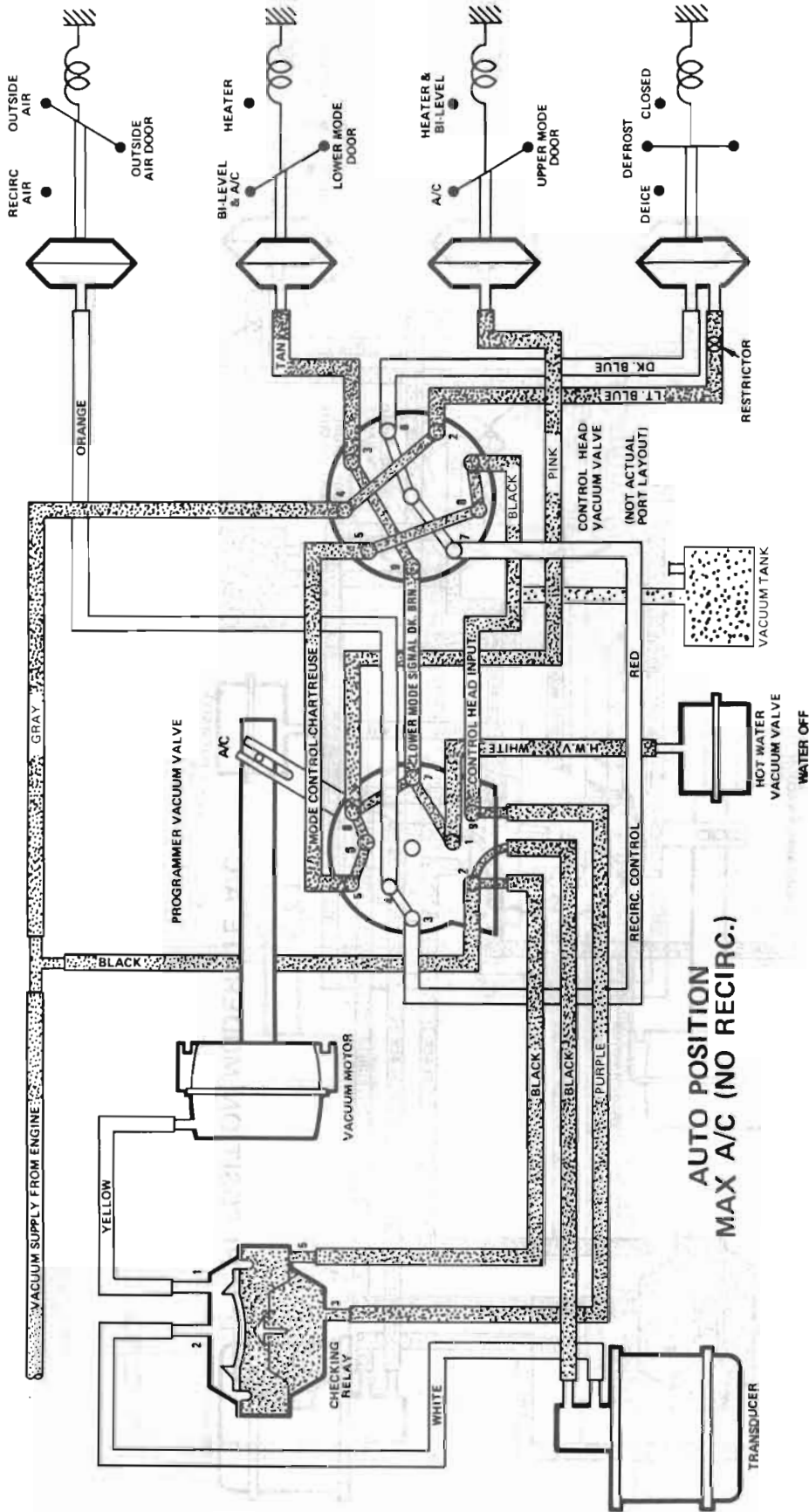

13-629

Figure 13-152 45-46-48-49000 Series Vacuum Circuits - AUTO Position MAX A/C (No Recirc)

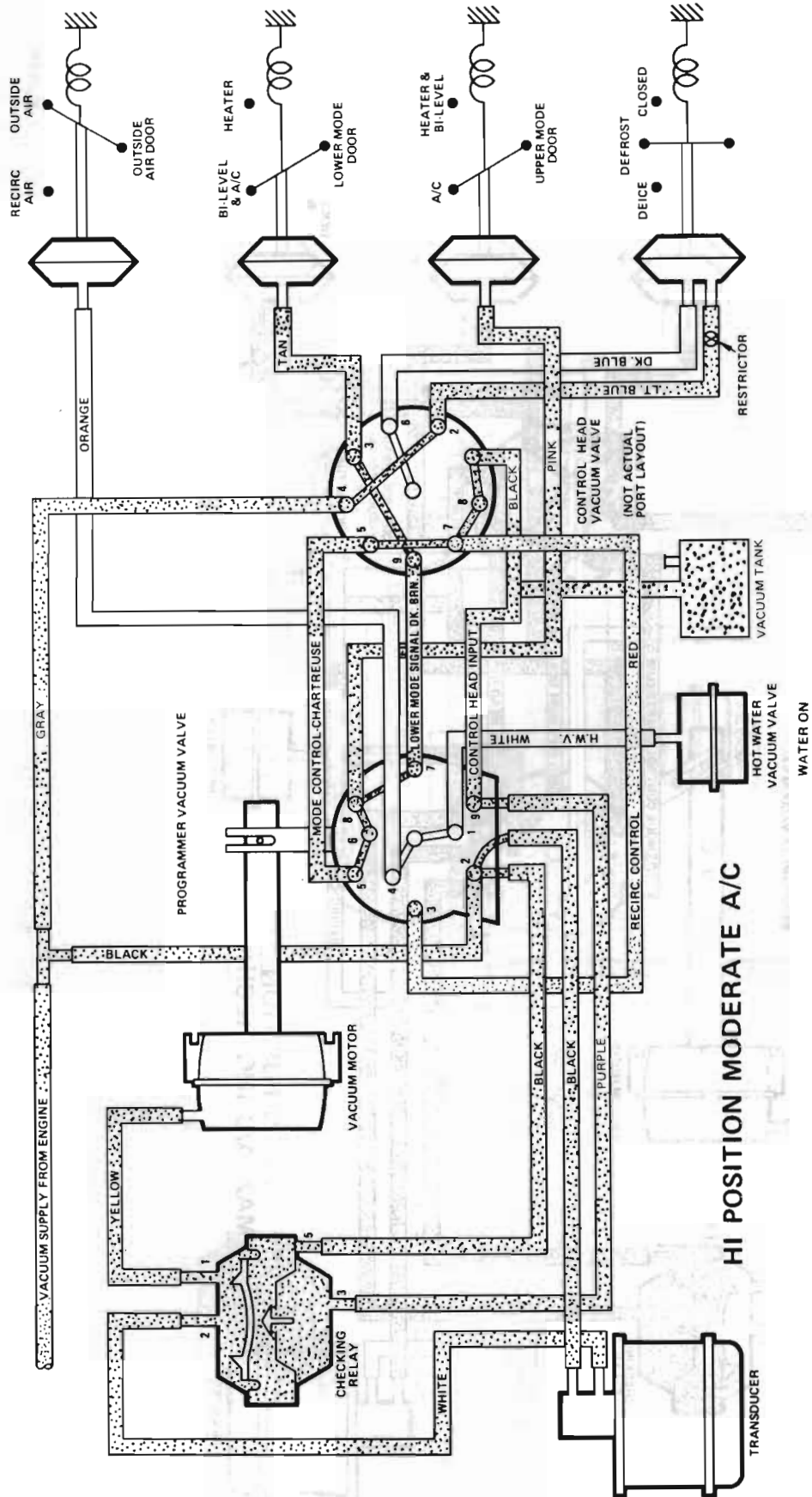
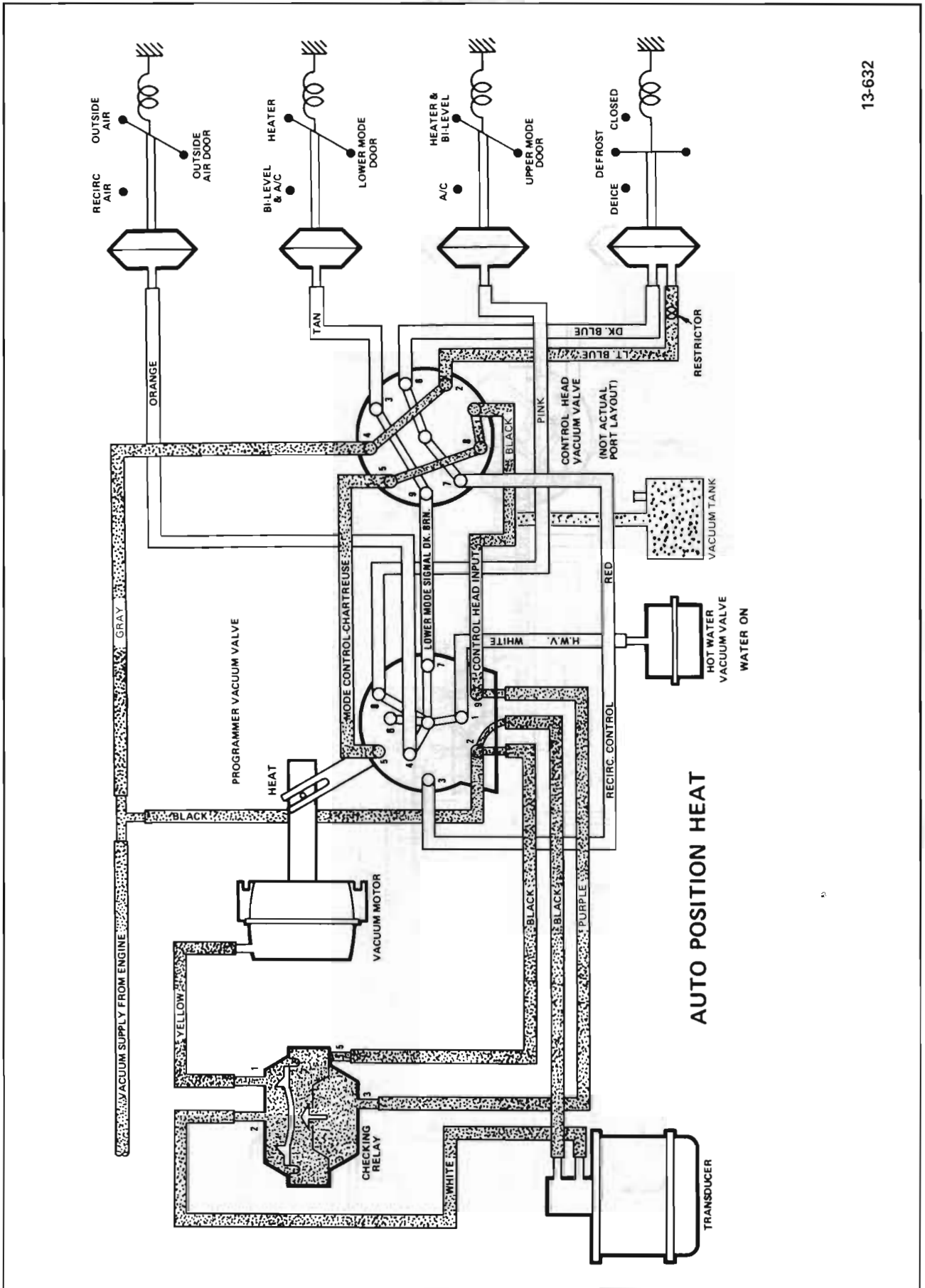

Figure 13-153 45-46-48-49000 Series Vacuum Circuits - System in HI Position Moderate A/C



13-632

Figure 13-154 45-46-48-49000 Series VACUUM Circuits - AUTO Position Heat

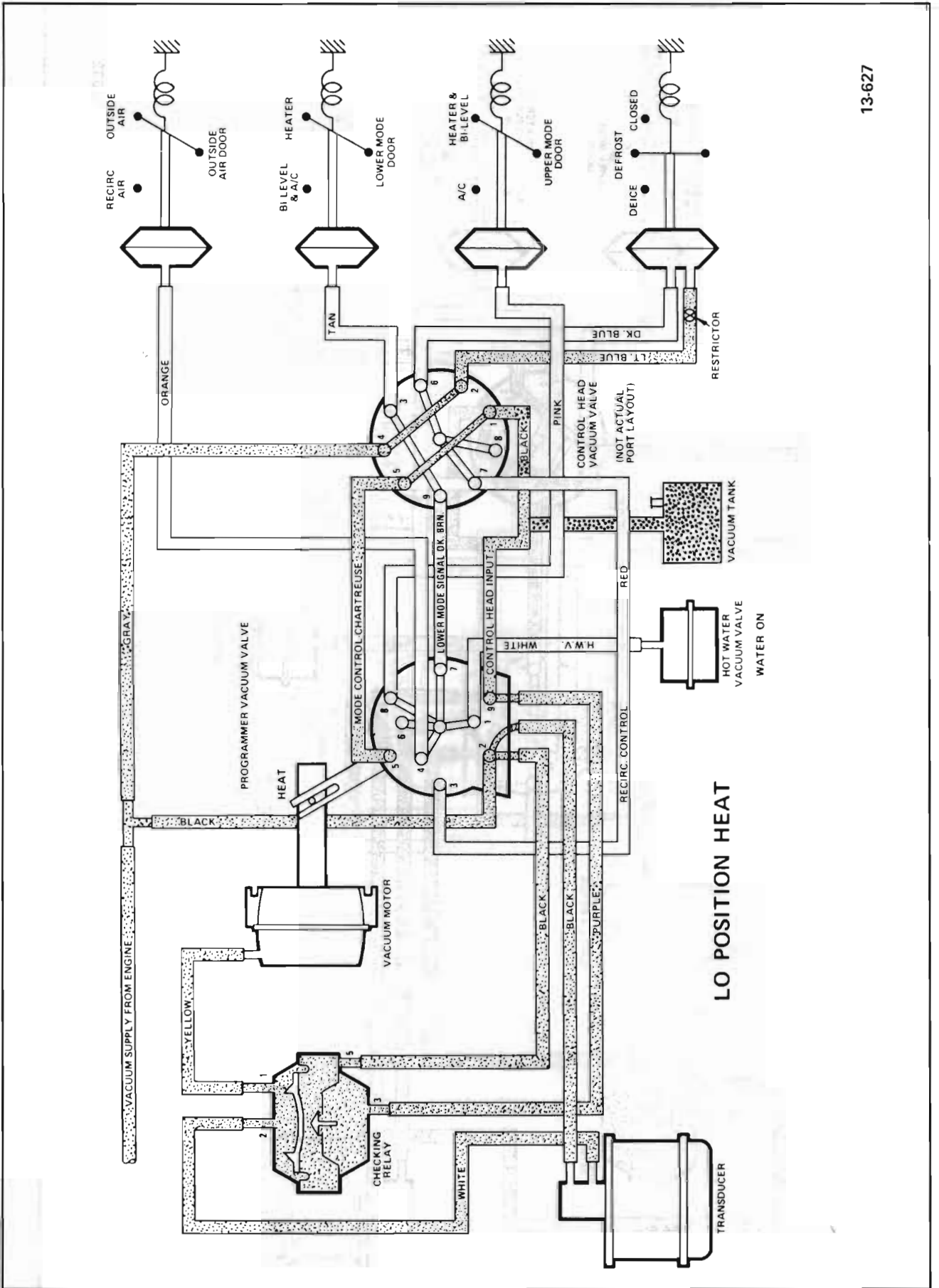
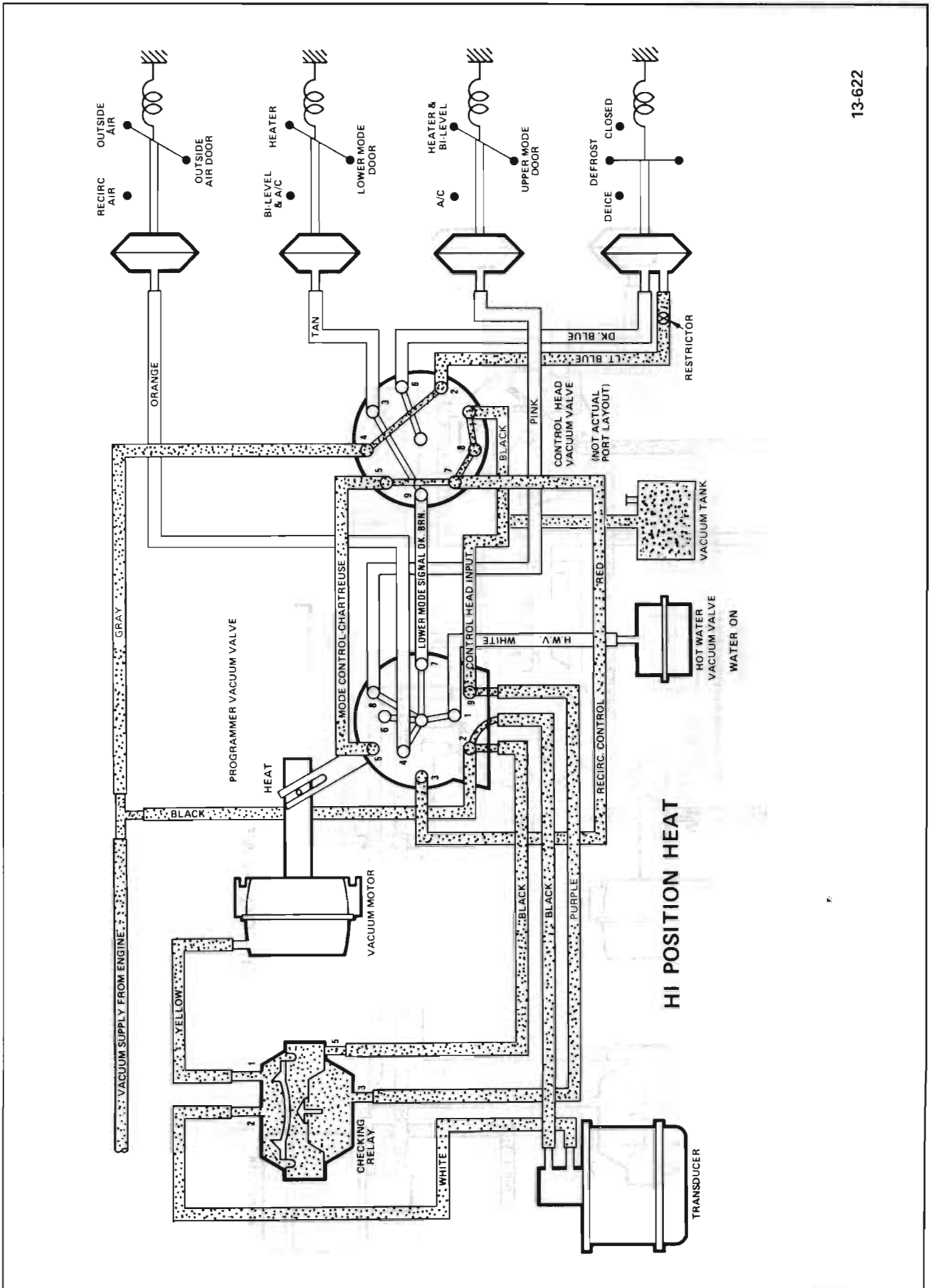
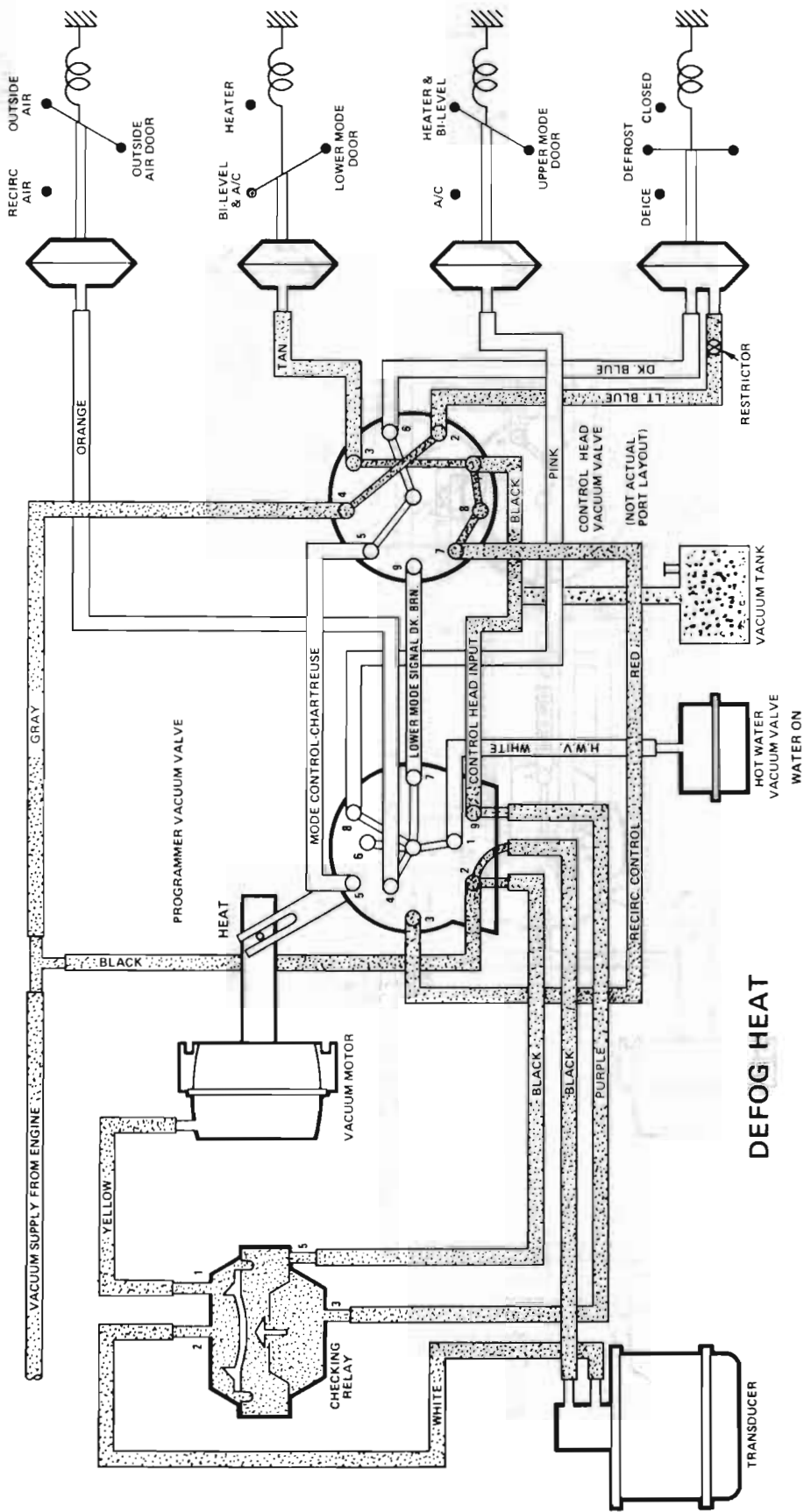

Figure 13-155 45-46-48-49000 Series Vacuum Circuits - System in LO Position Heat



13-622

Figure 13-156 45-46-48-49000 Series Vacuum Circuits - System in HI Position Heat



13-620

Figure 13-157 45-46-48-49000 Series Vacuum Circuits - System in DEFOG Heat

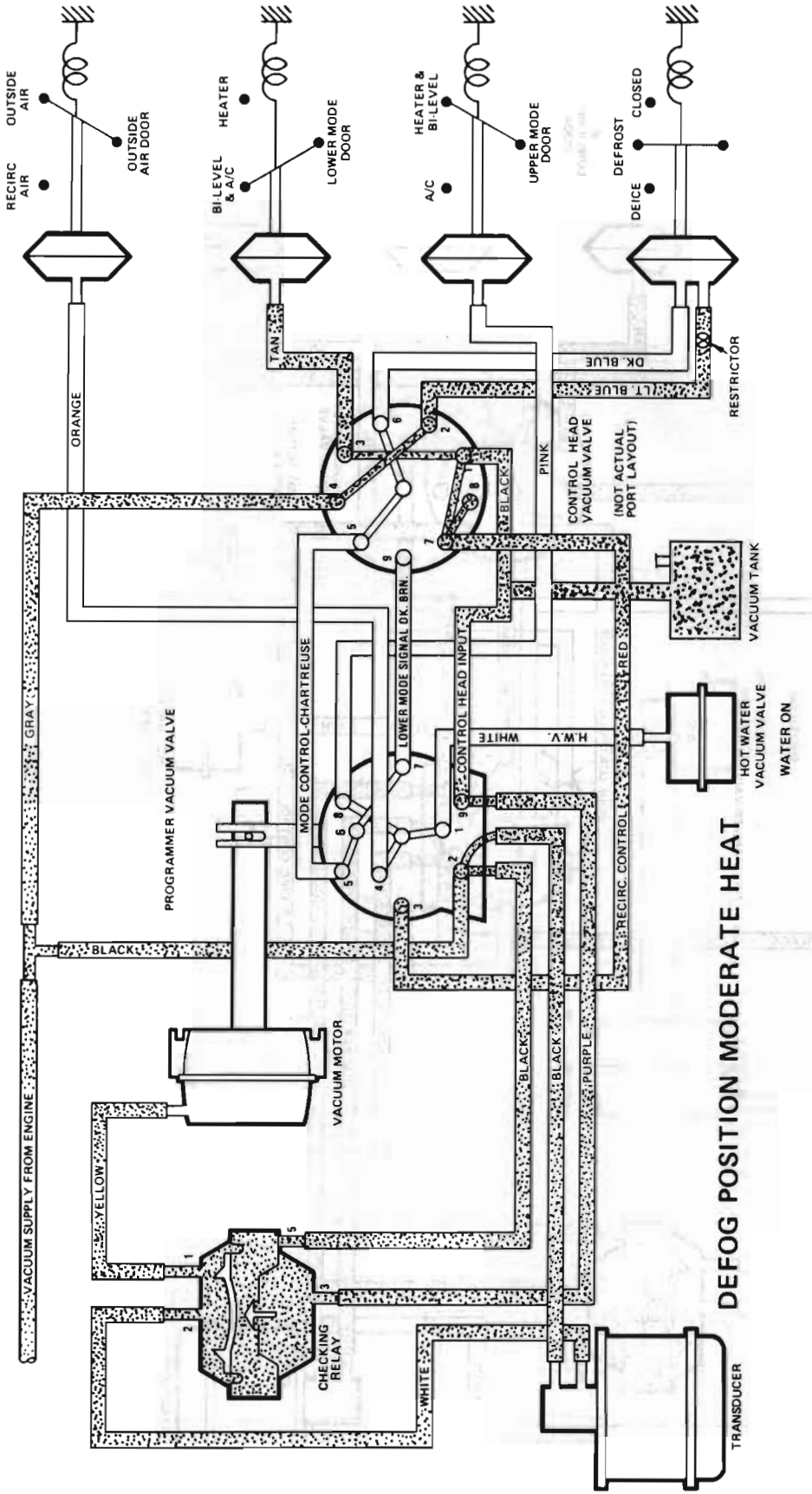

13-680

Figure 13-158 45-46-48-49000 Series Vacuum Circuits - DEFROG Position Moderate Heat

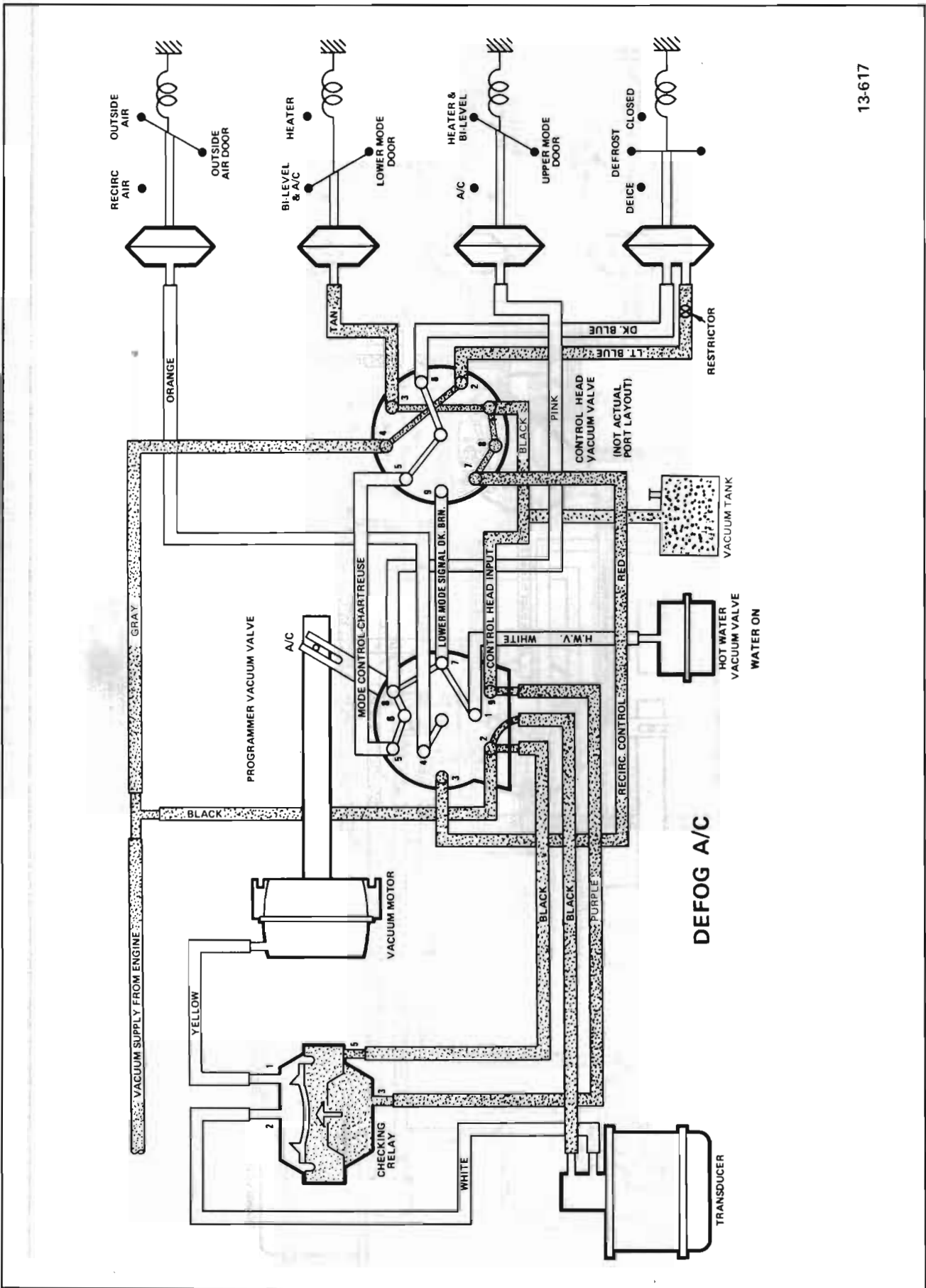
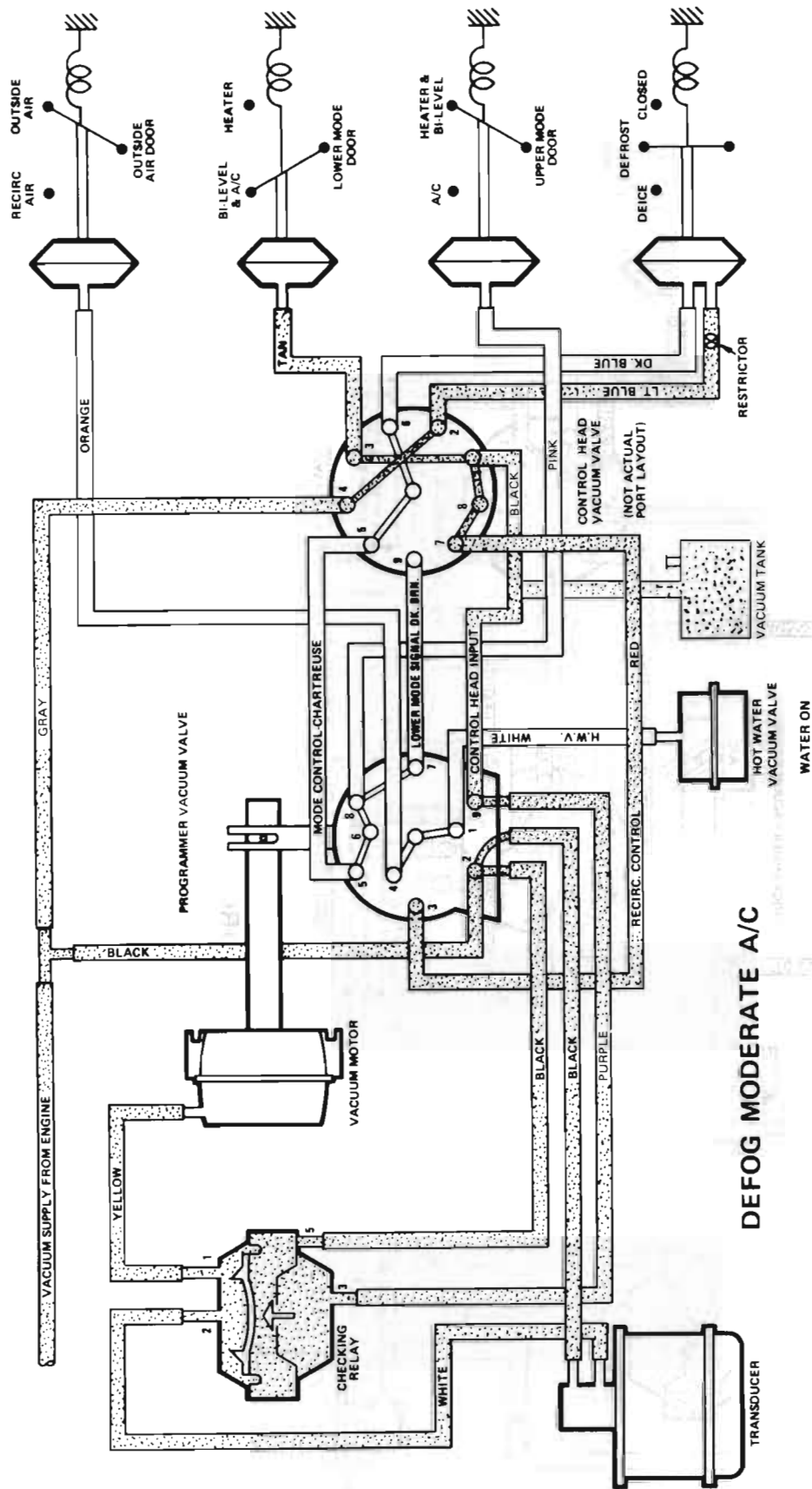

Figure 13-159 45-46-48-49000 Series Vacuum Circuits - System in DEFOG A/C



DEFOG MODERATE A/C

13-618

Figure 13-160 45-46-48-49000 Series Vacuum Circuits - System in DEFOG Moderate A/C

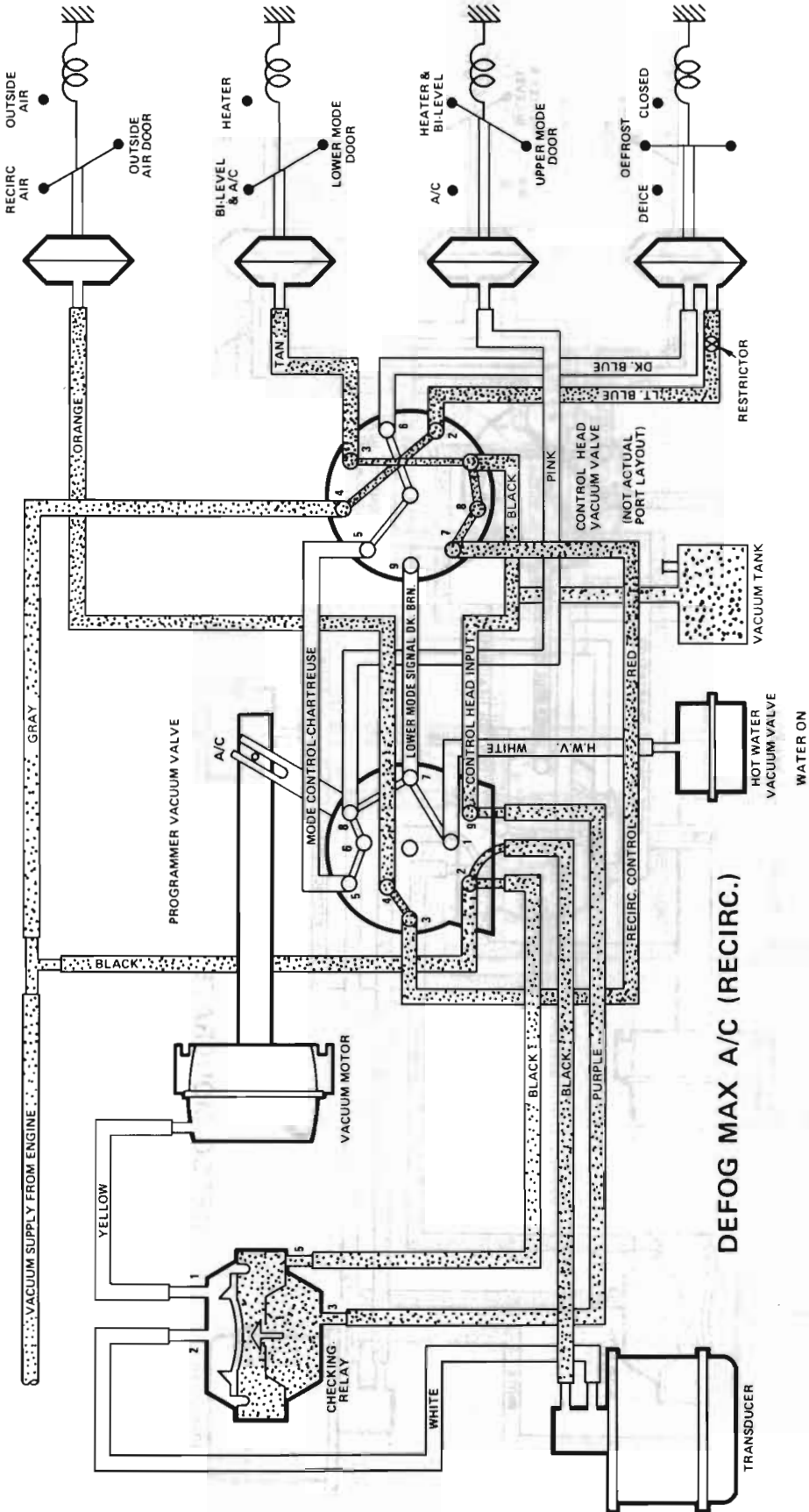
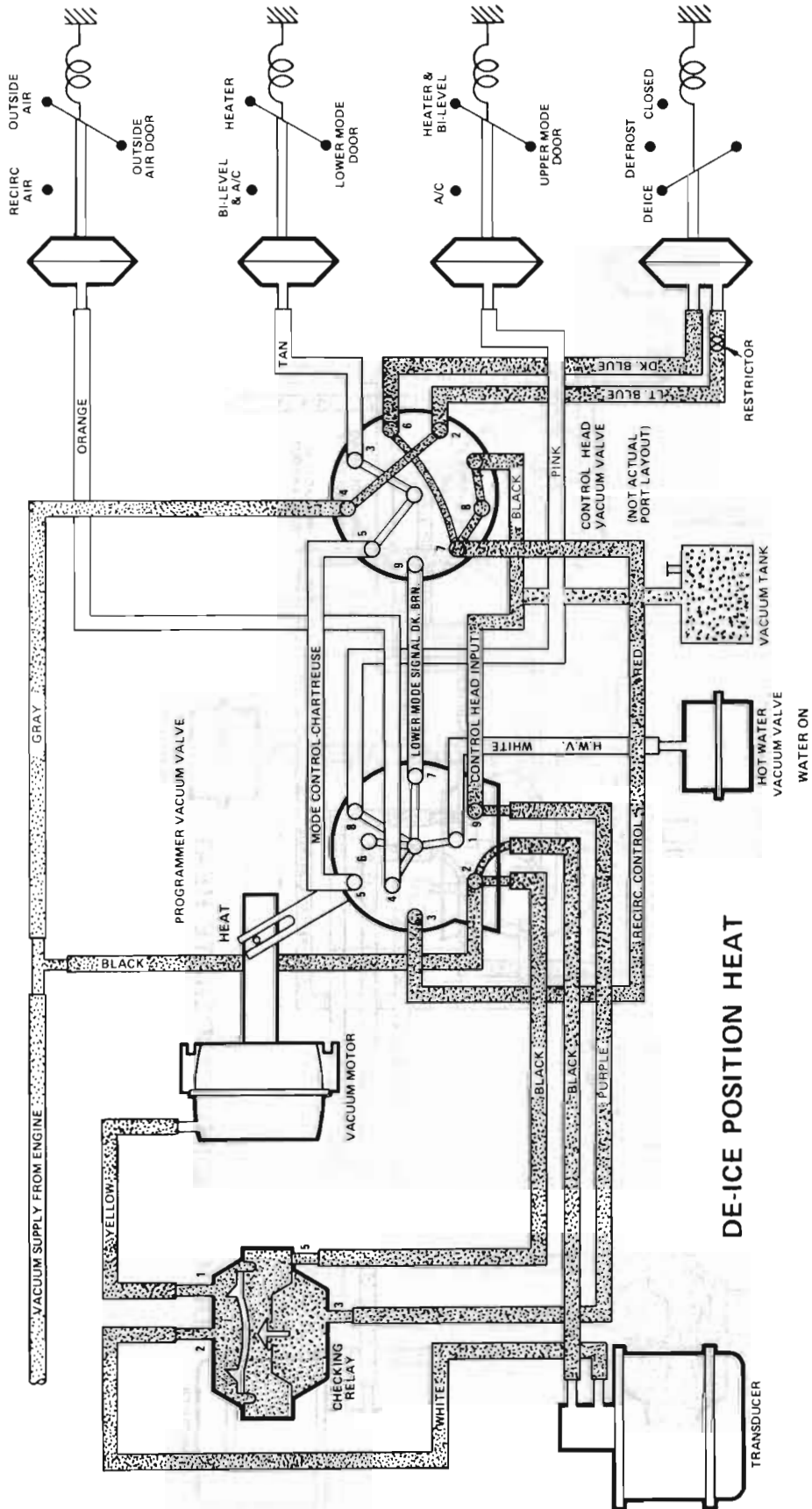

Figure 13-161 45-46-48-49000 Series Vacuum Circuits - System in DEFOG MAX A/C (Recirc)



DE-ICE POSITION HEAT

13-616

Figure 13-162 45-46-48-49000 Series Vacuum Circuits - System in DEICE Position Heat

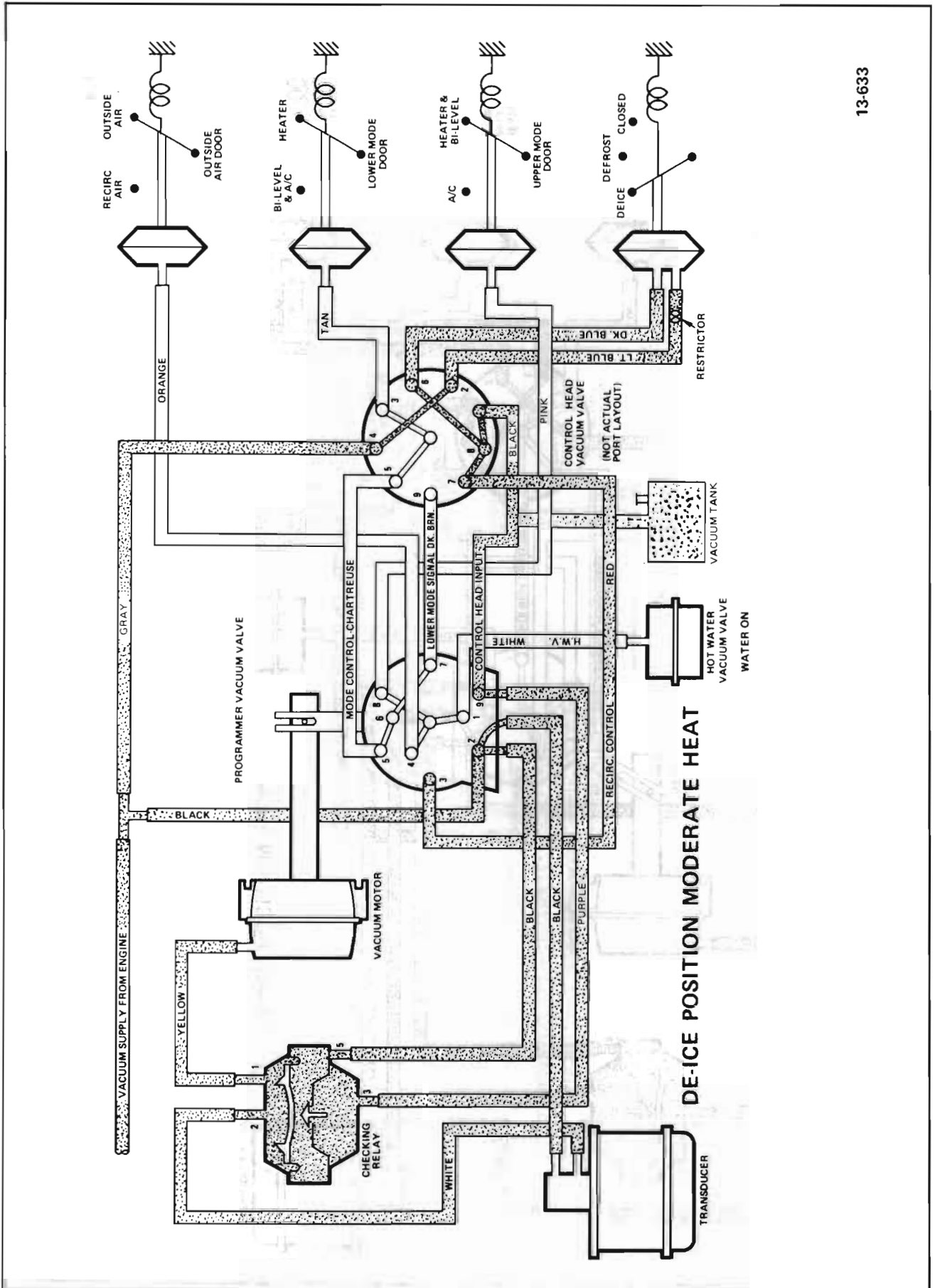

13-633

Figure 13-163 45-46-48-49000 Series Vacuum Circuits - DEICE Position Moderate Heat

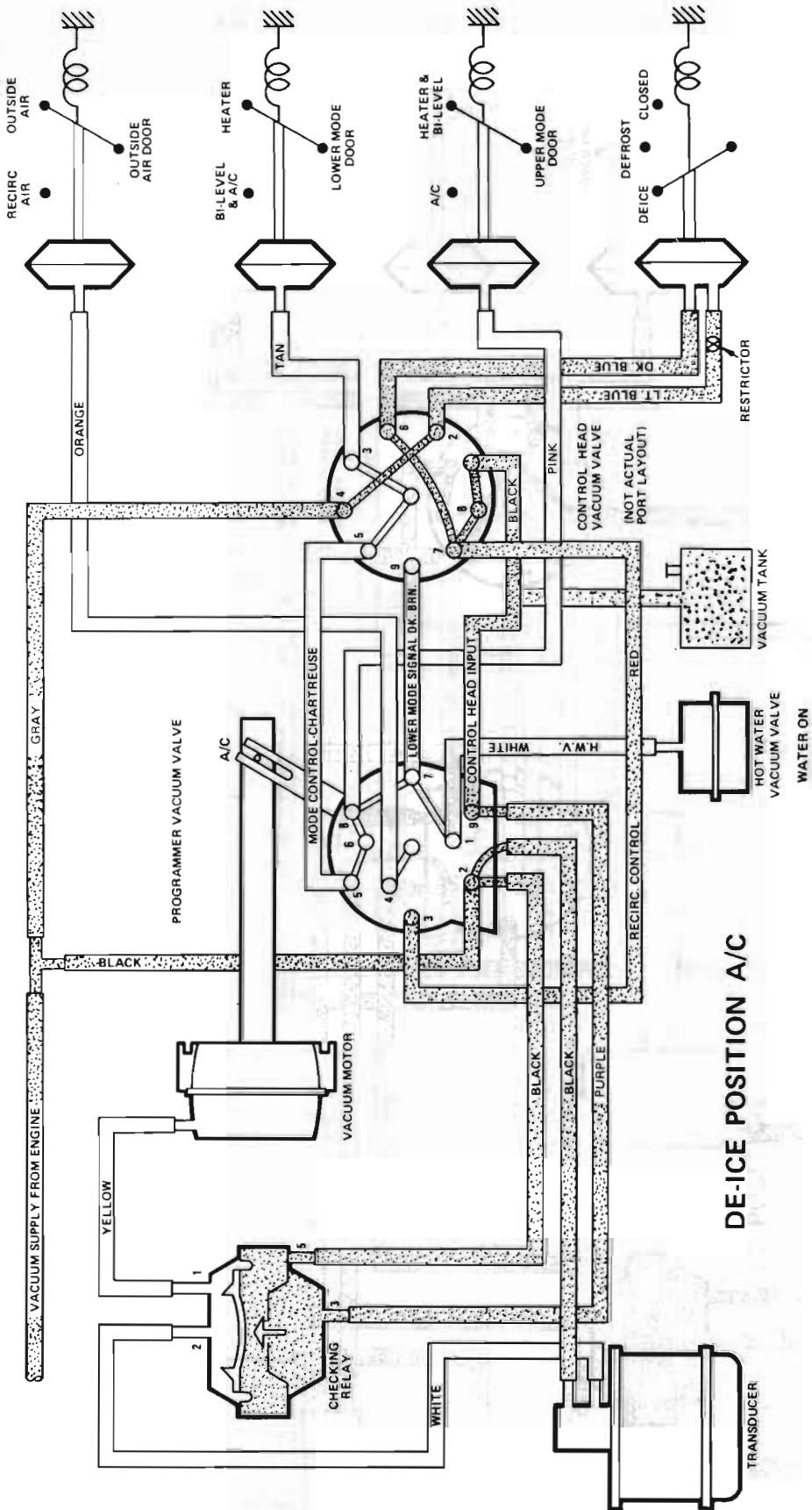

13-613

Figure 13-164 45-46-48-49000 Series Vacuum Circuits - System in DEICE Position A/C

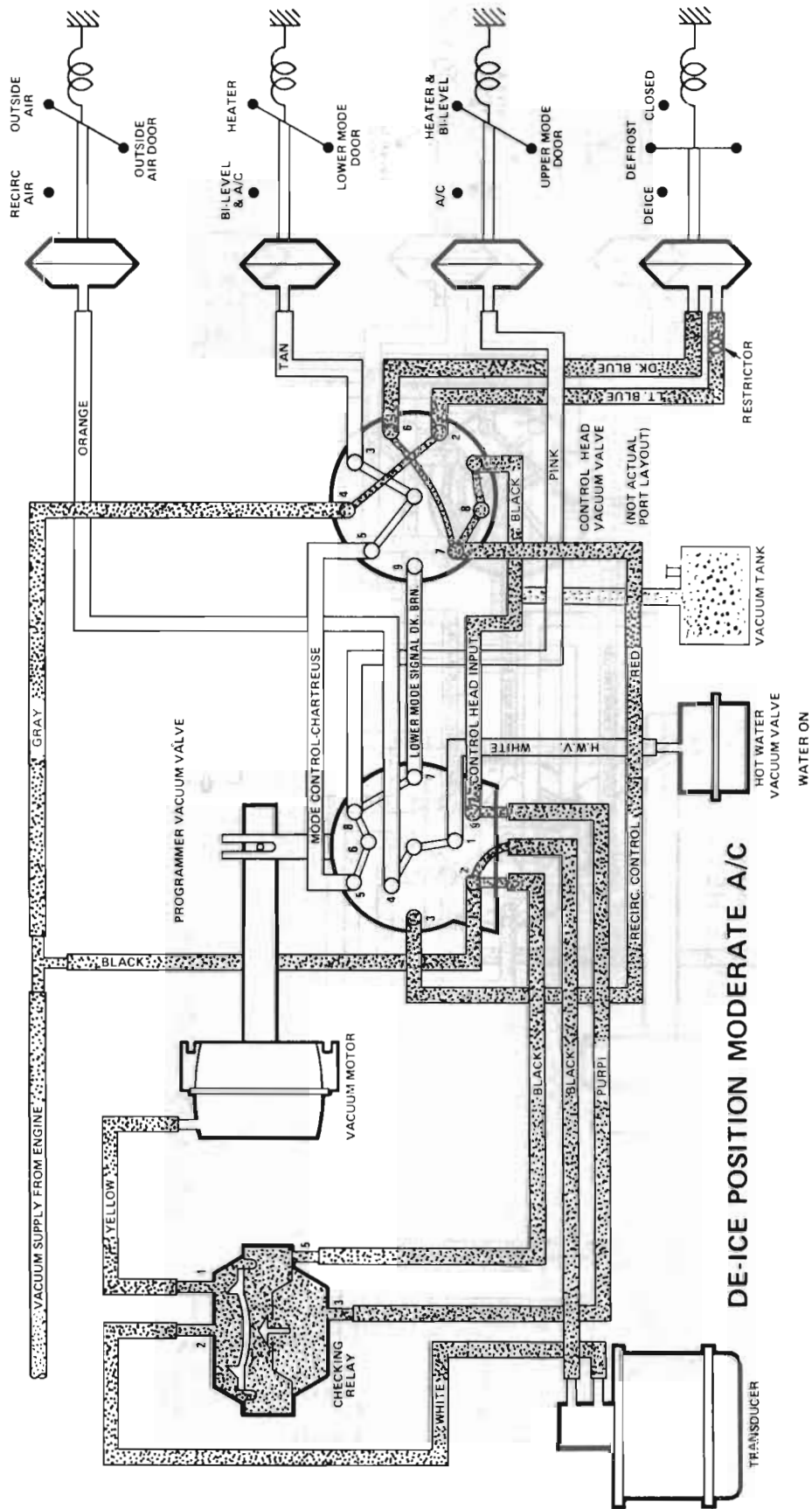
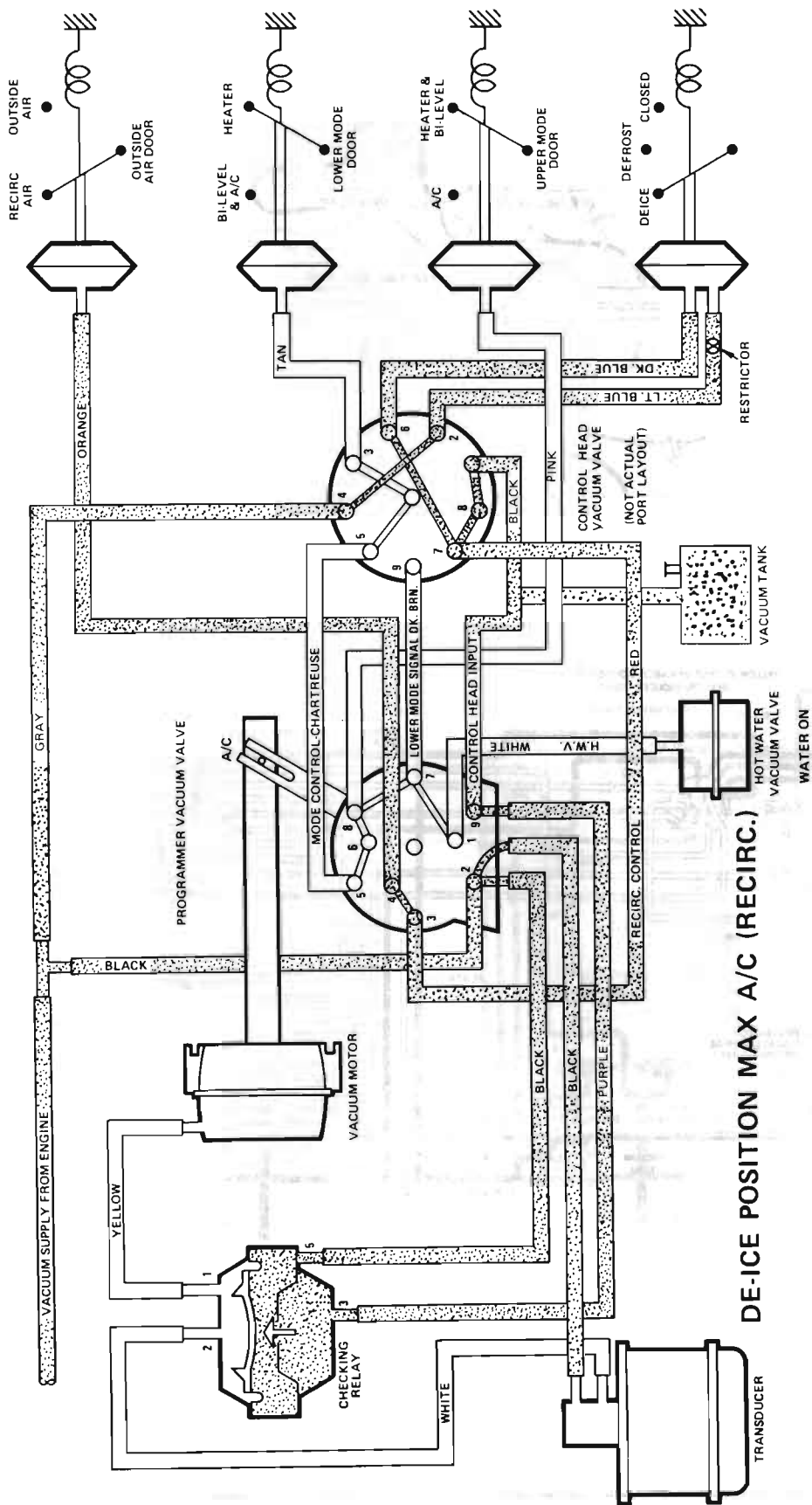

Figure 13-165 45-46-48-49000 Series Vacuum Circuits - System in DEICE Position Moderate A/C



13-615

Figure 13-166 45-46-48-49000 Series Vacuum Circuit - System in DEICE Position MAX A/C (Recirc)

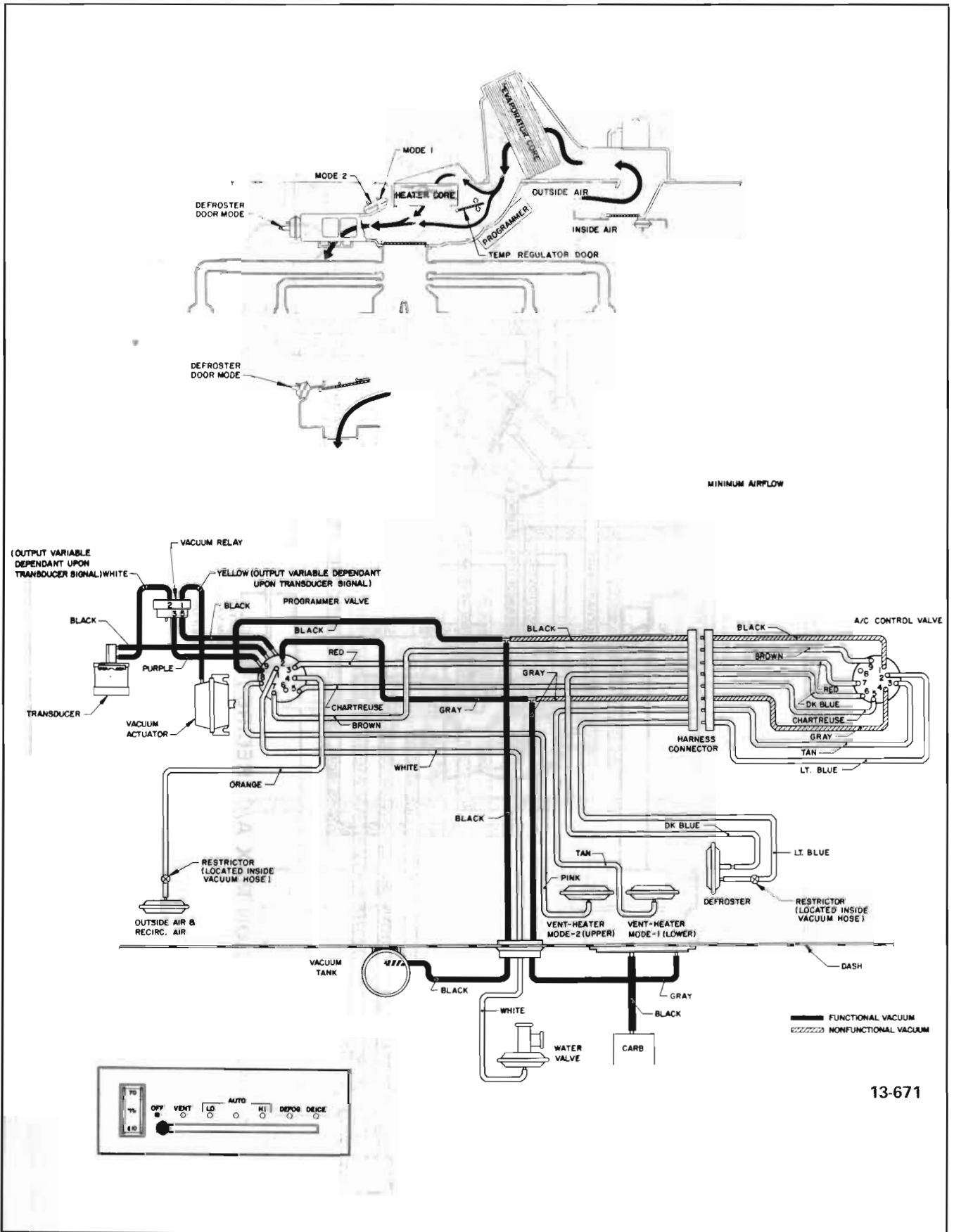

Figure 13-167 45-46-48-49000 Series Air Flow and Vacuum Circuits - System in OFF Position

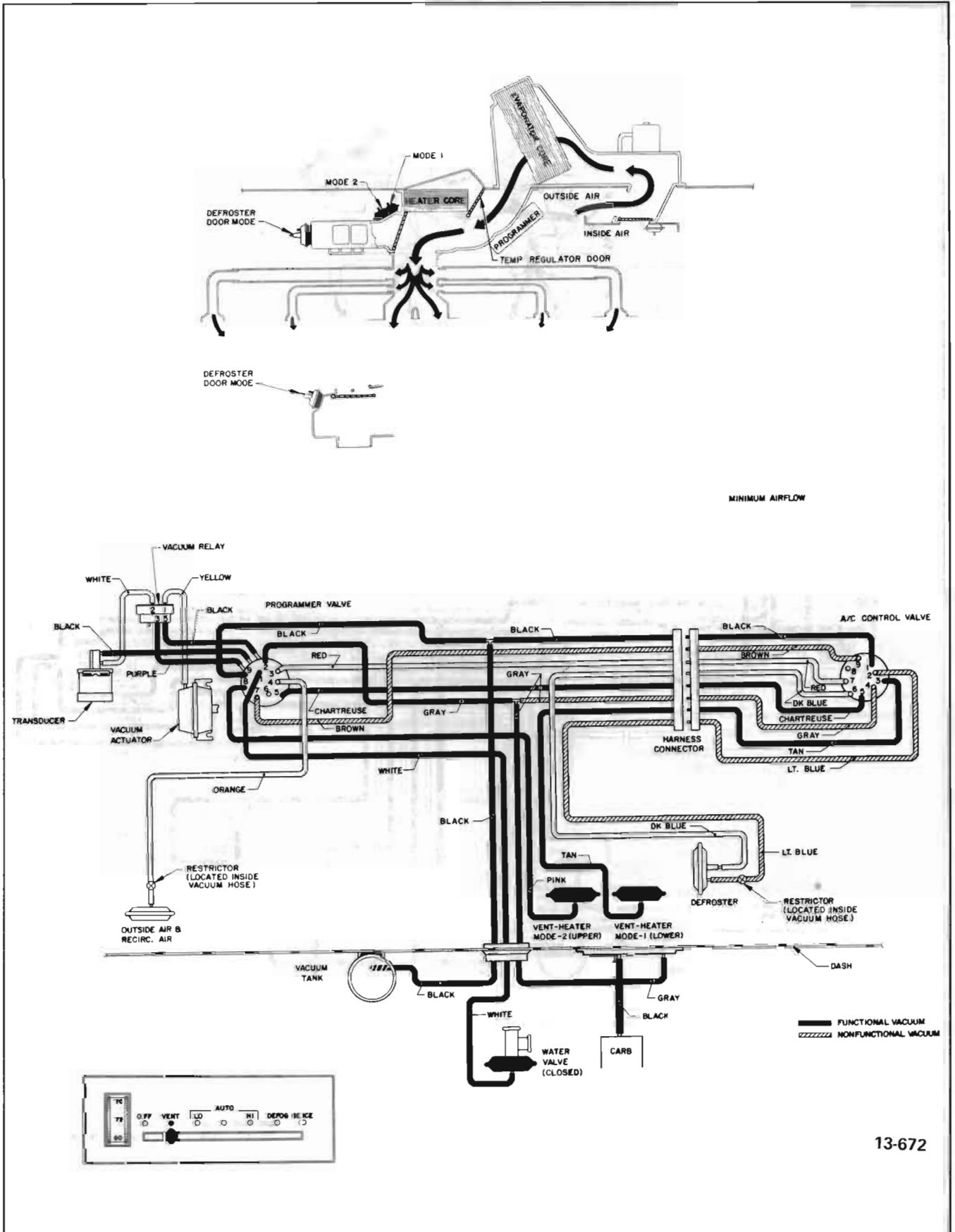
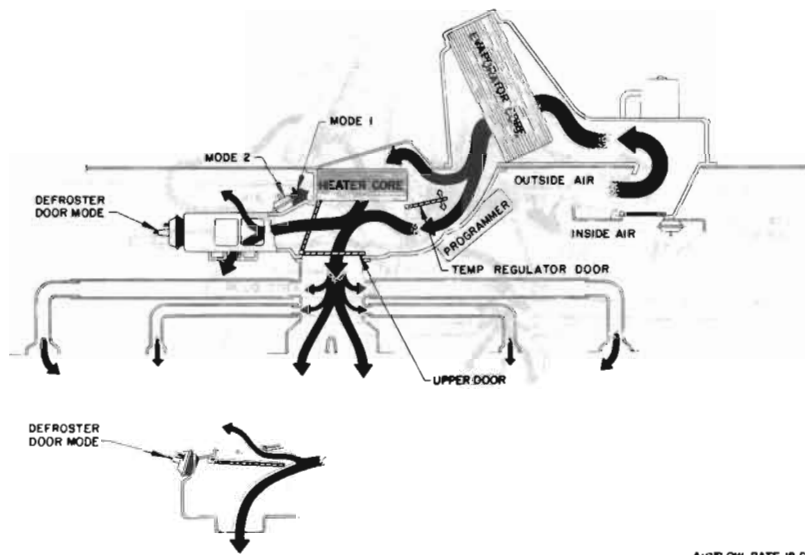
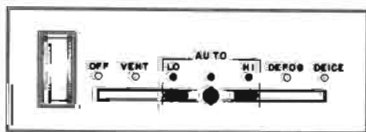
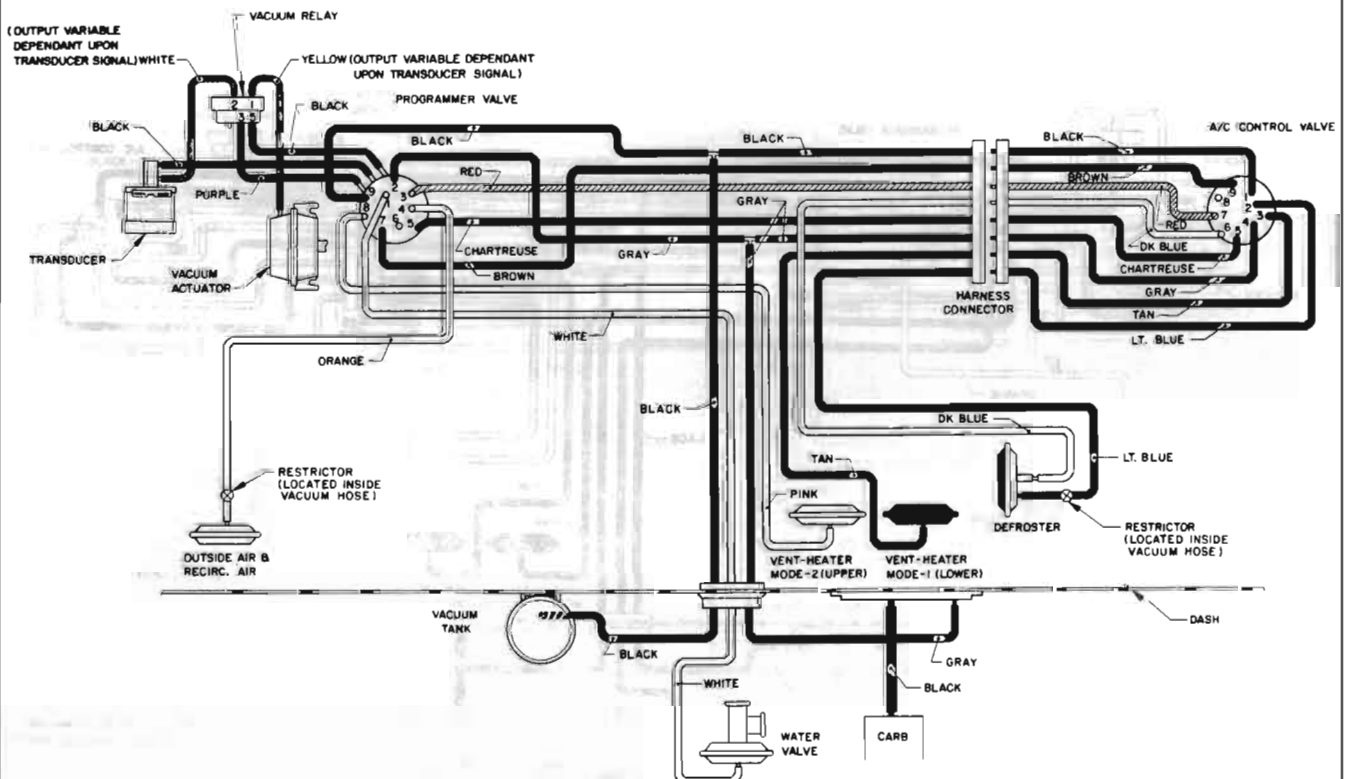

Figure 13-168 45-46-48-49000 Series Air Flow and Vacuum Circuits - System in VENT Position



AIRFLOW RATE IS DICTATED BY SENSORS—MEDIUM TO MAXIMUM AIRFLOW.



— FUNCTIONAL VACUUM
▨ FUNCTIONAL VACUUM AT "HI" POSITION ONLY

Figure 13-169 45-46-48-49000 Series Air Flow and Vacuum Circuits - System in AUTO Position

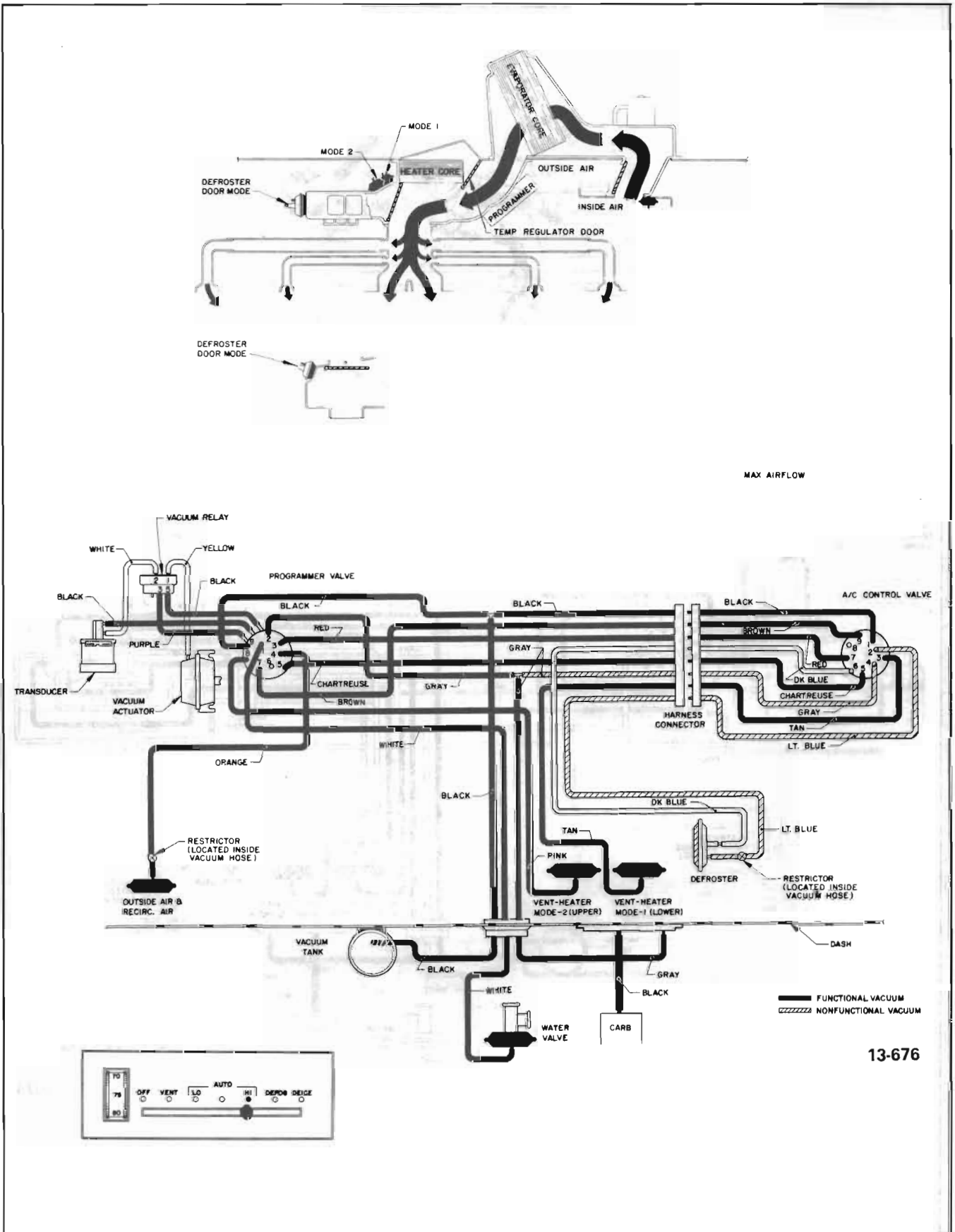
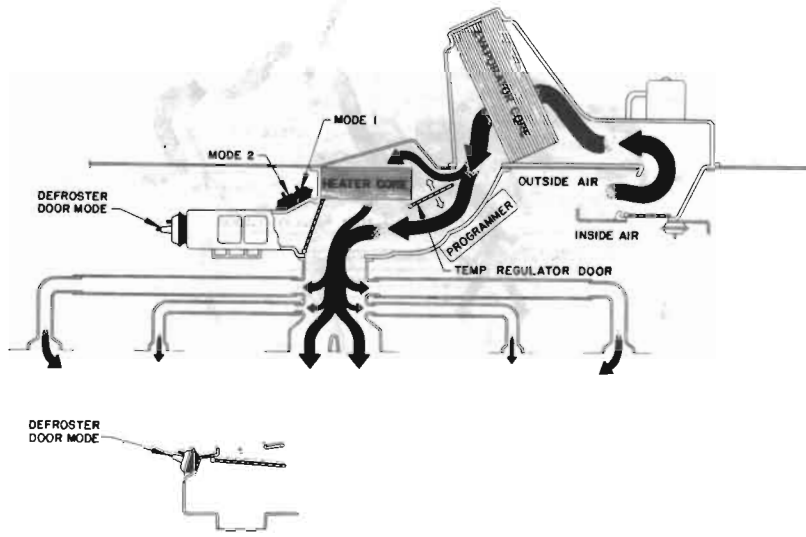
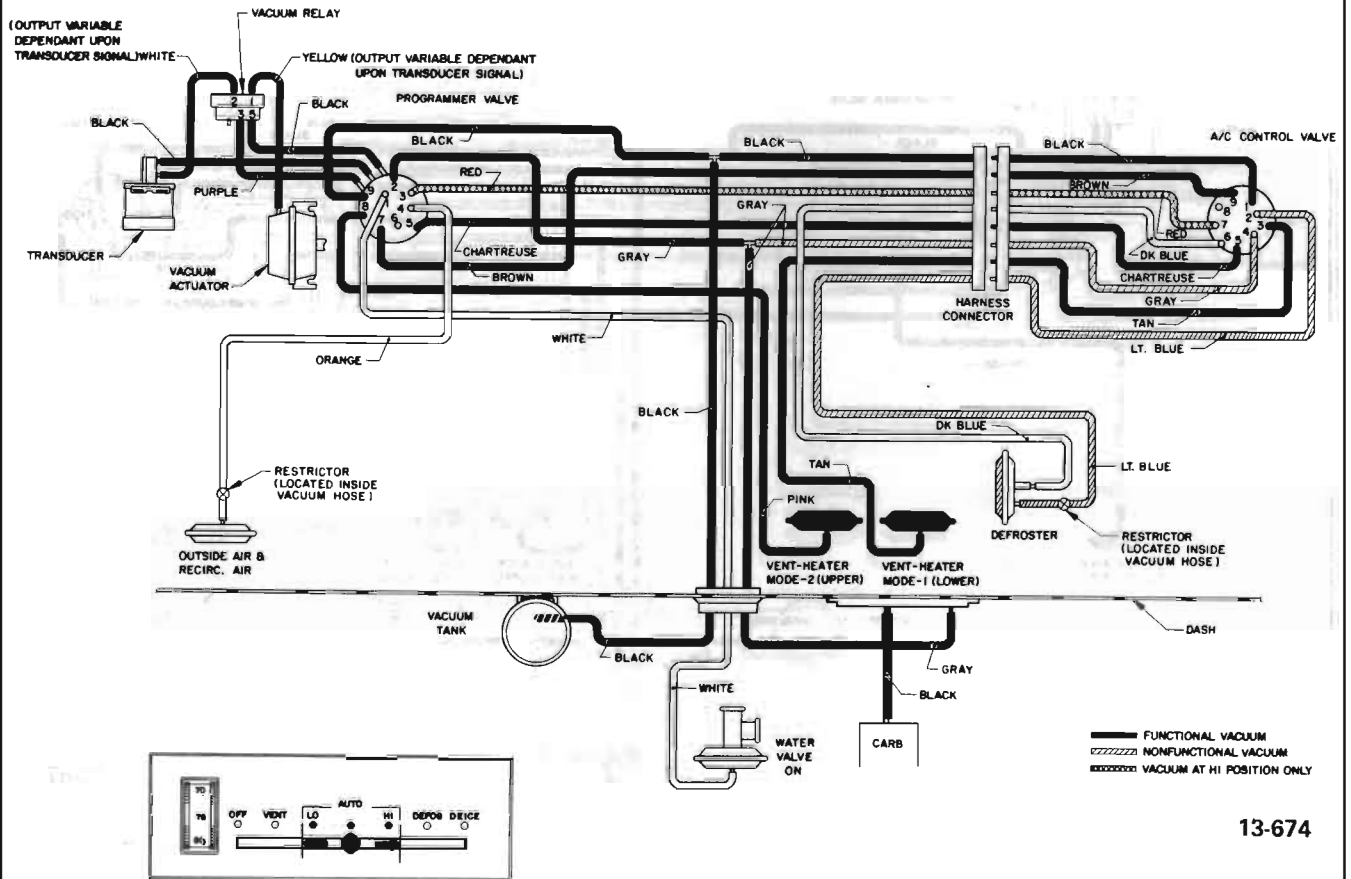

Figure 13-170 45-46-48-49000 Series Air Flow and Vacuum Circuits - System in AUTO HI Position



AIRFLOW RATE IS DICTATED BY SENSORS — MEDIUM TO MAXIMUM AIRFLOW.



13-674

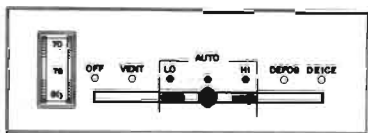
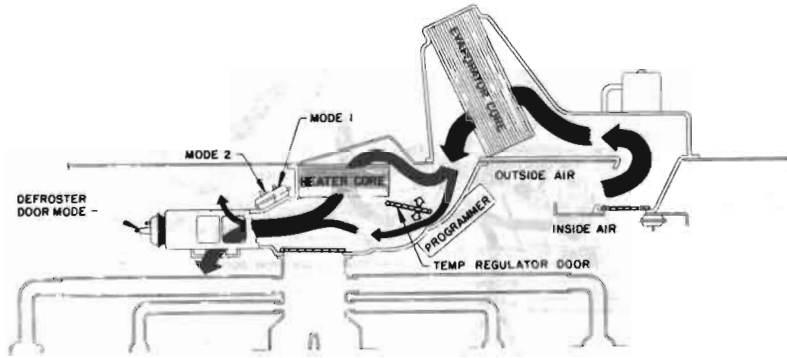
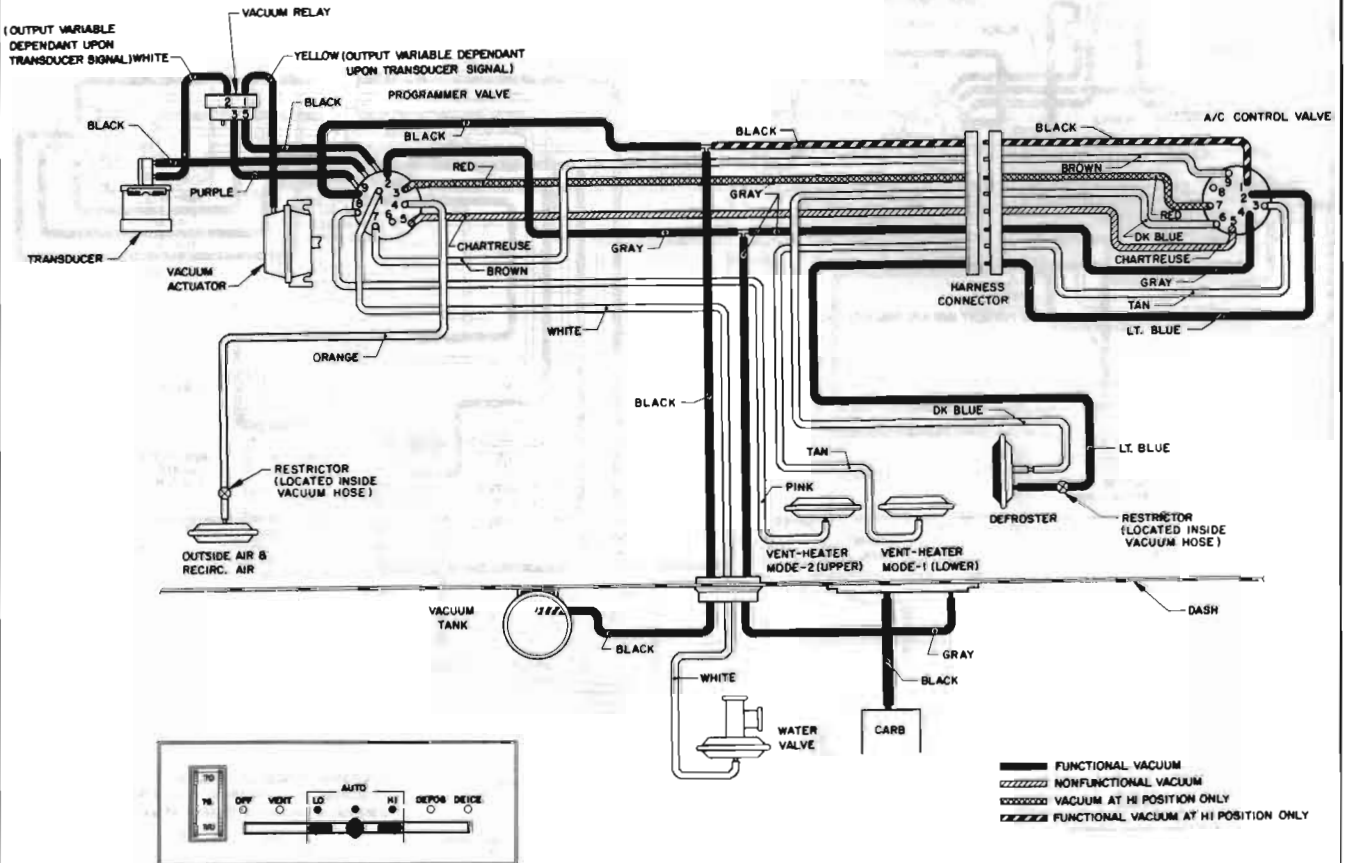

Figure 13-171 45-46-48-49000 Series Air Flow and Vacuum Circuits - System in AUTO Position



AIRFLOW RATE IS DICTATED BY SENSORS — MEDIUM TO MAXIMUM AIRFLOW



13-675

Figure 13-172 45-46-48-49000 Series Air Flow and Vacuum Circuits - System in AUTO Position

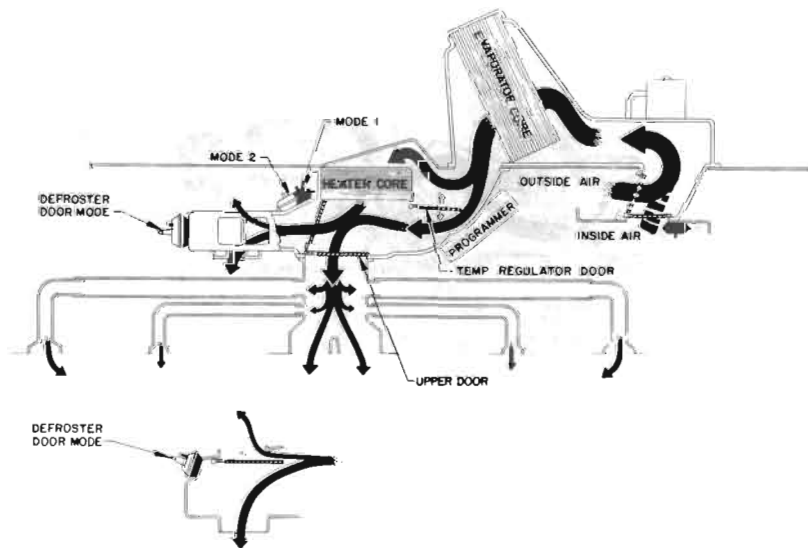

AIRFLOW RATE IS DICTATED BY SENSORS - MEDIUM TO MAXIMUM AIRFLOW.

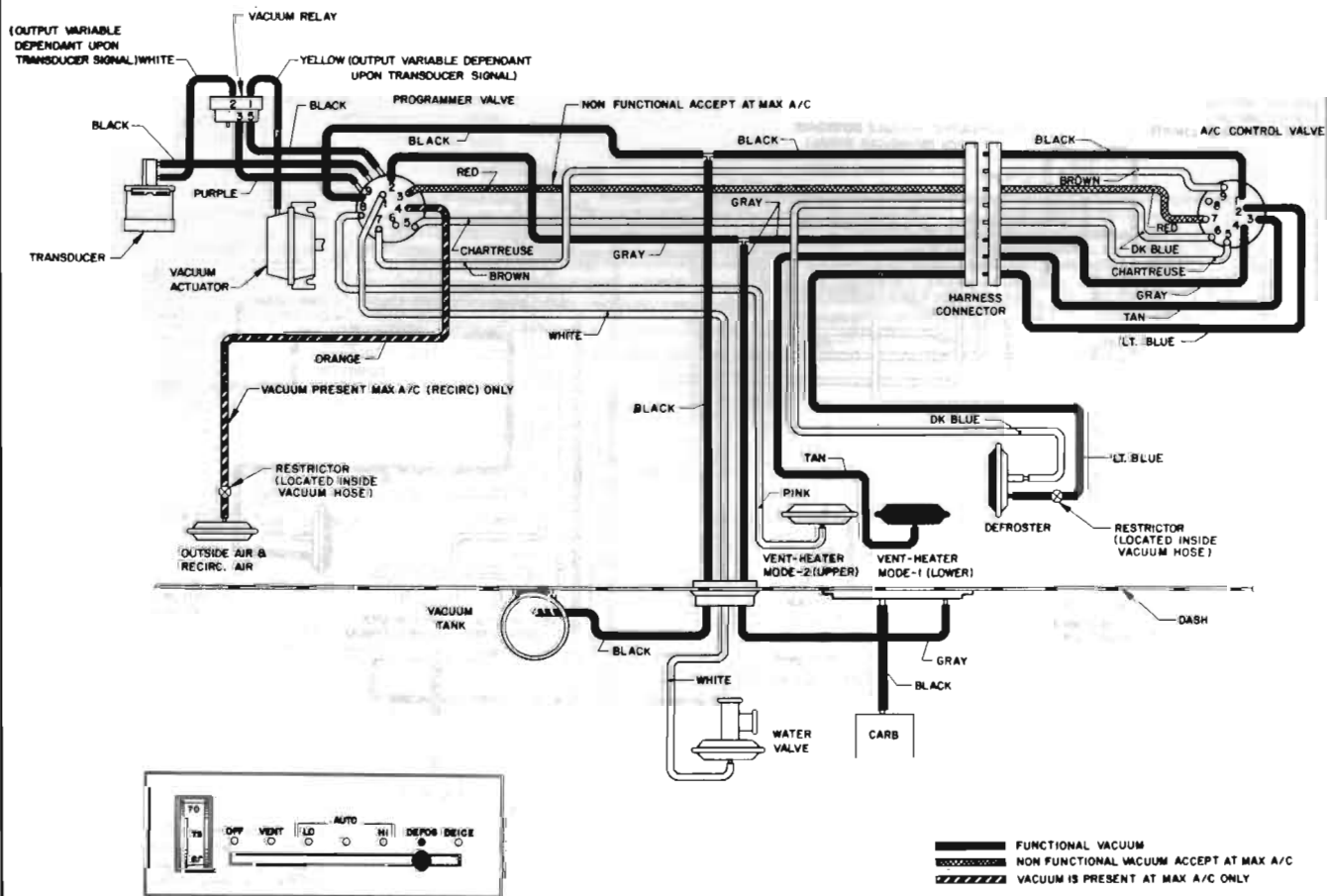

Figure 13-173 45-46-48-49000 Series Air Flow and Vacuum Circuits - System in DEFOG Position

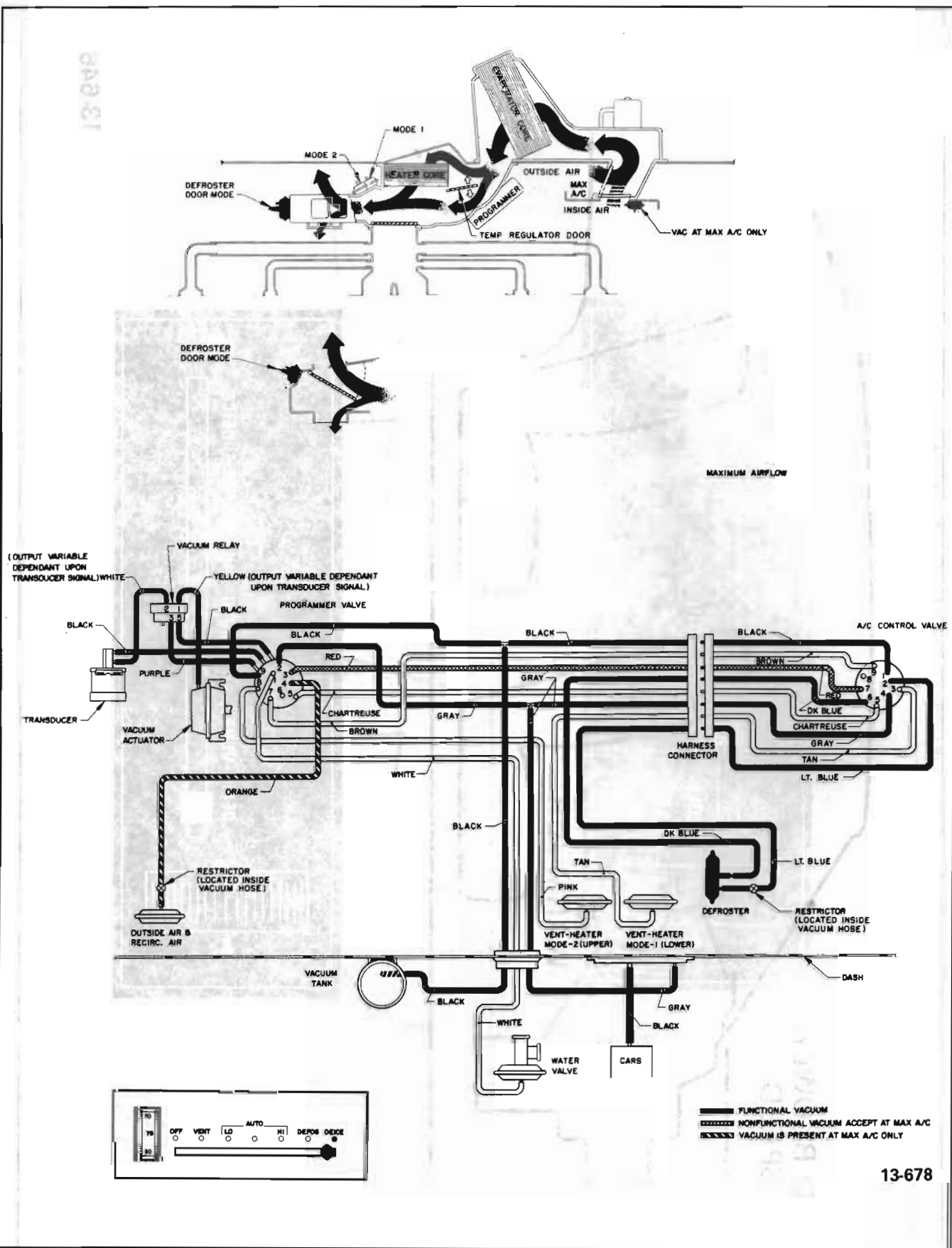
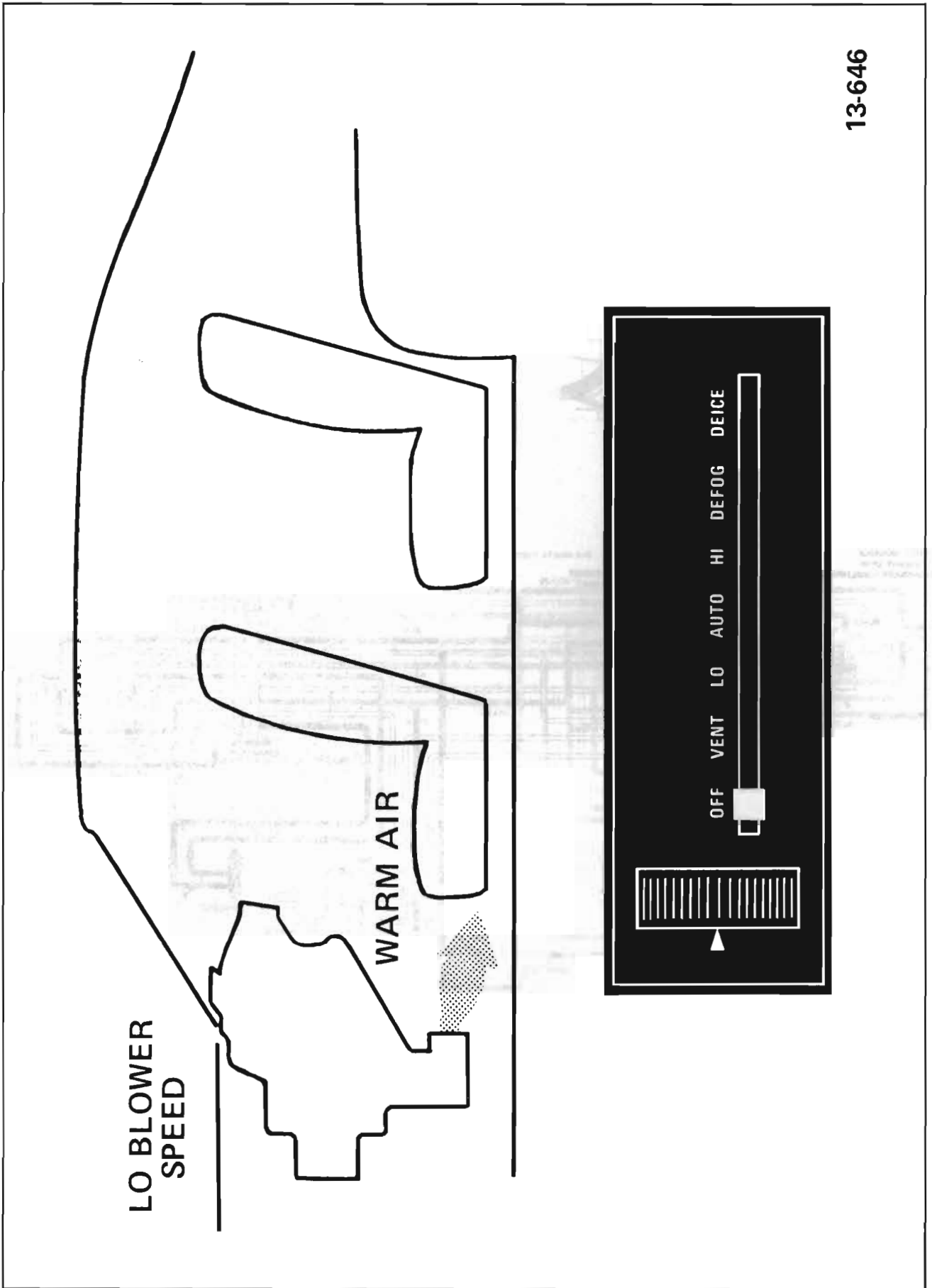
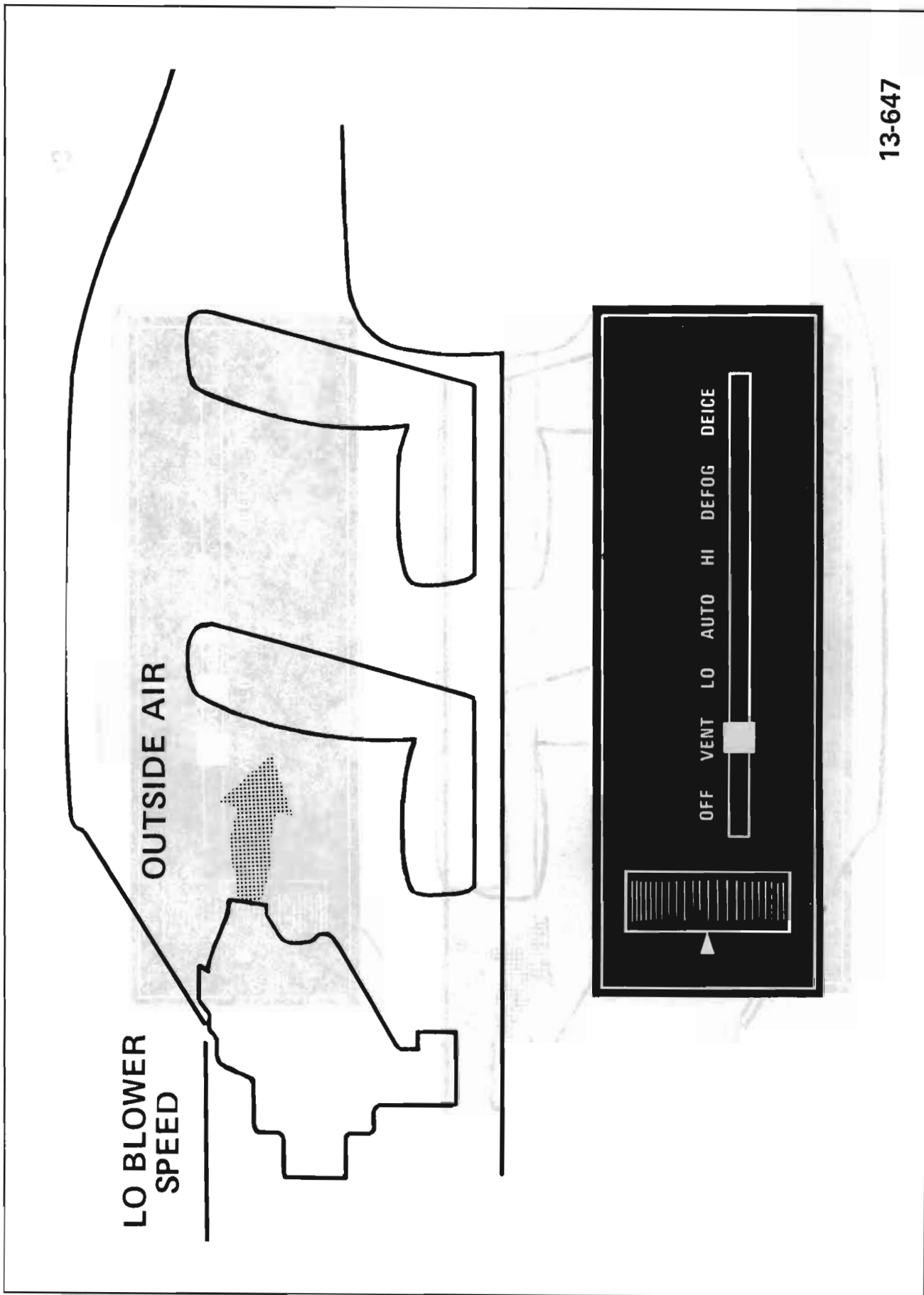

Figure 13-174 45-46-48-49000 Series Air Flow and Vacuum Circuits - System in DEICE Position



13-646

Figure 13-175 Comfort Level - Selector Lever in OFF



13-647

Figure 13-176 Comfort Level - Selector Lever in VENT

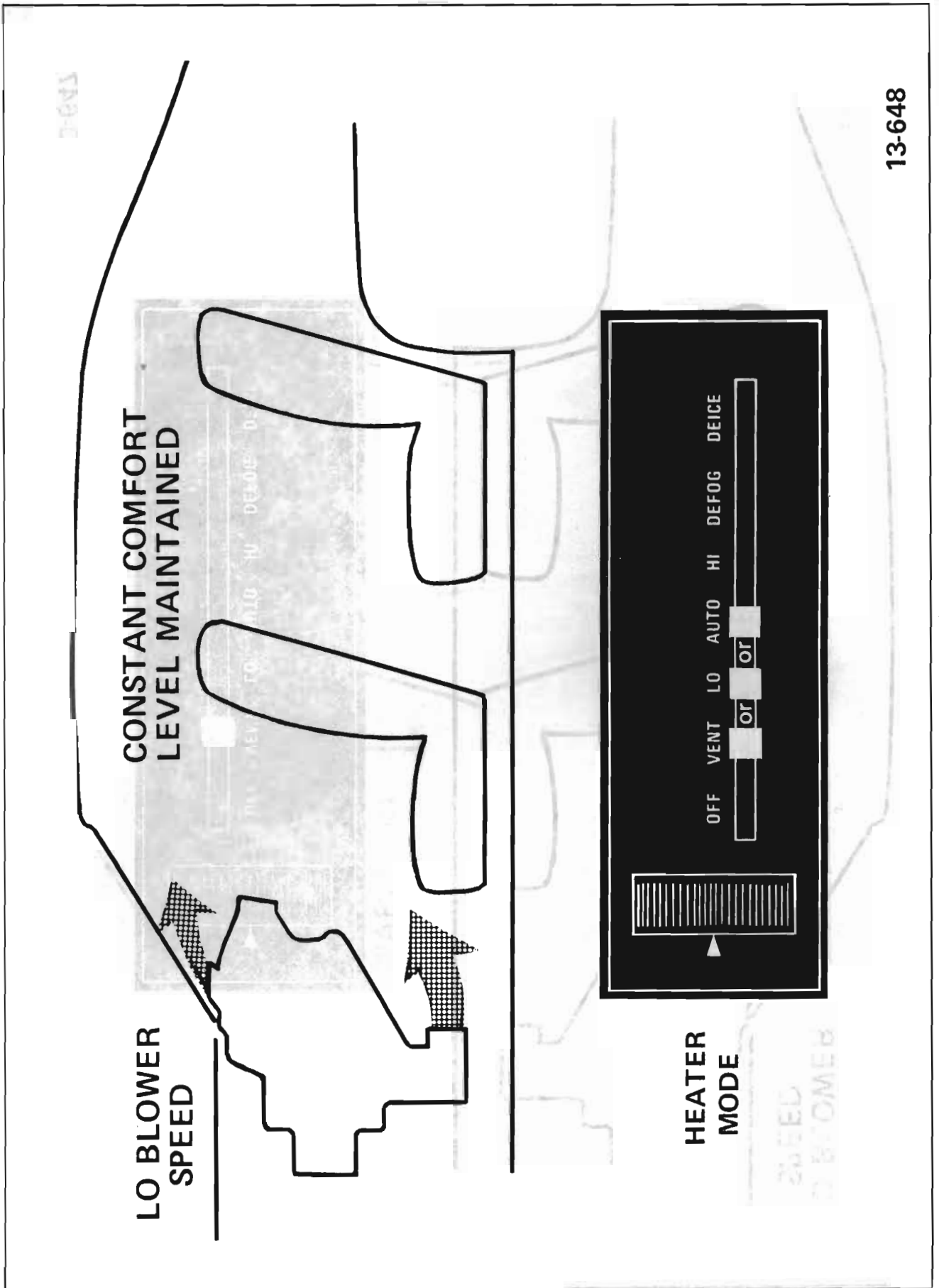
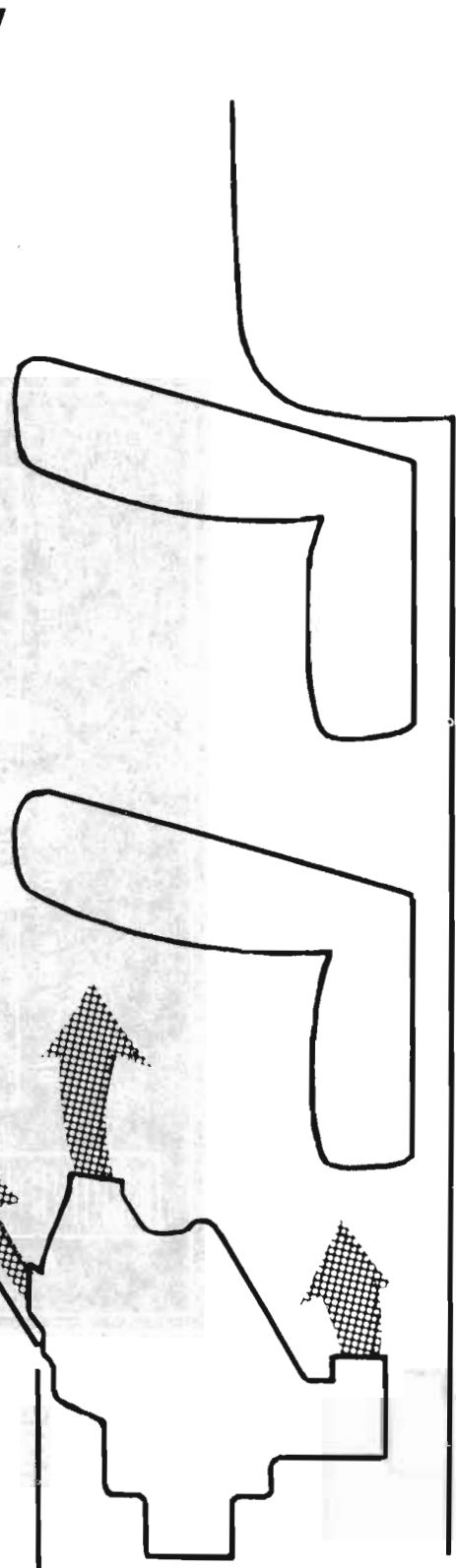

Figure 13-177 Comfort Level - Selector Lever in AUTO LO

LO, M1, M2 & HI
BLOWER SPEEDS

CONSTANT COMFORT
LEVEL MAINTAINED



BI - LEVEL
MODE

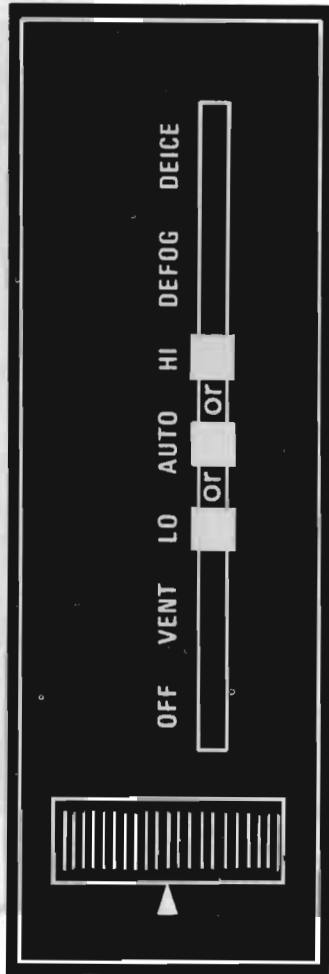

13-649

Figure 13-178 Comfort Level - Selector Lever in AUTO

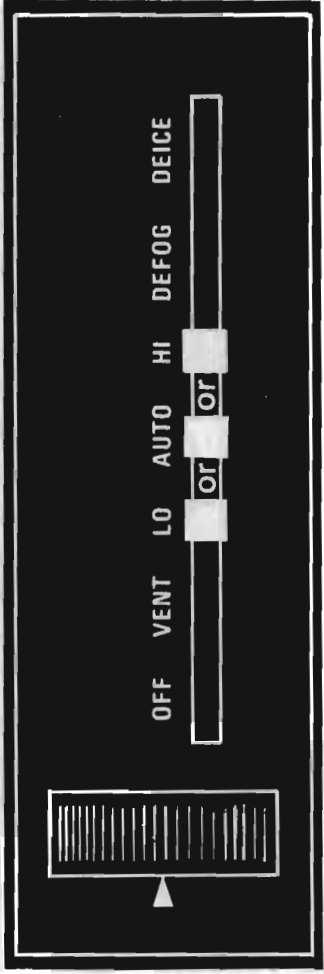
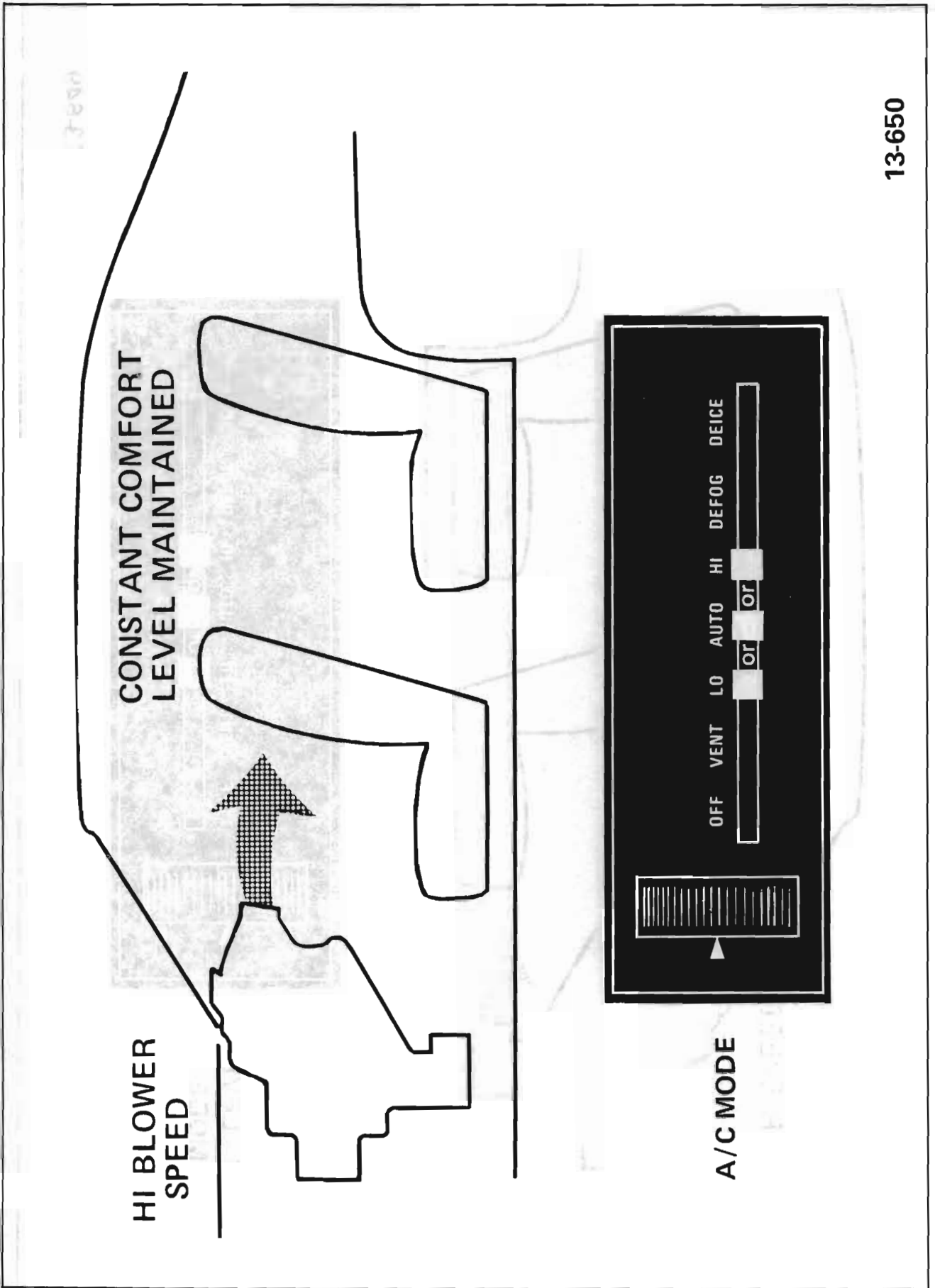

A/C MODE

13-650

Figure 13-179 Comfort Level - Selector Lever in AUTO HI

LO, M1, M2 & HI
BLOWER SPEEDS

CONSTANT COMFORT
LEVEL MAINTAINED

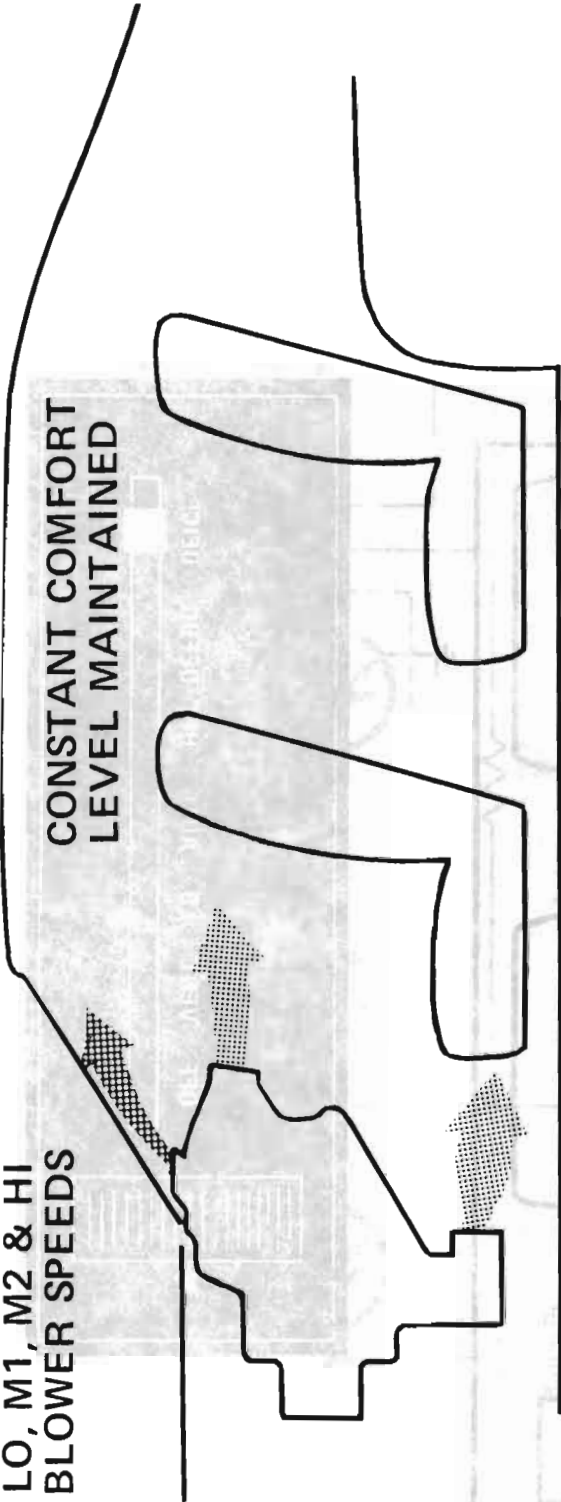

NOTE: DEFROSTER BLEED IS DELAYED 20 - 60 SECONDS AFTER STARTING CAR.

13-651

Figure 13-180 Comfort Level - Selector Lever in DEFOG

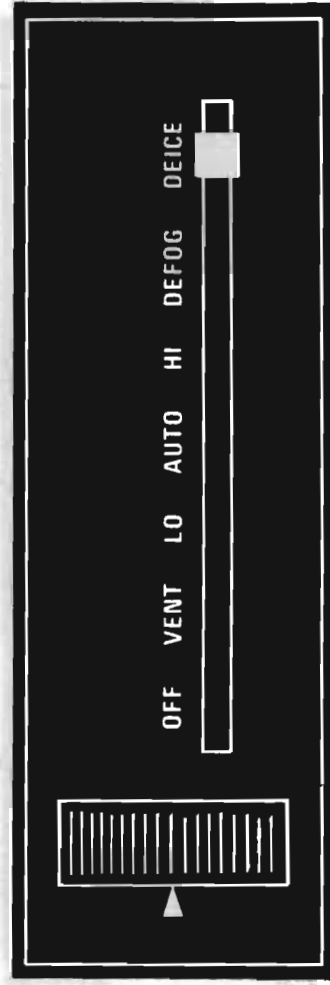
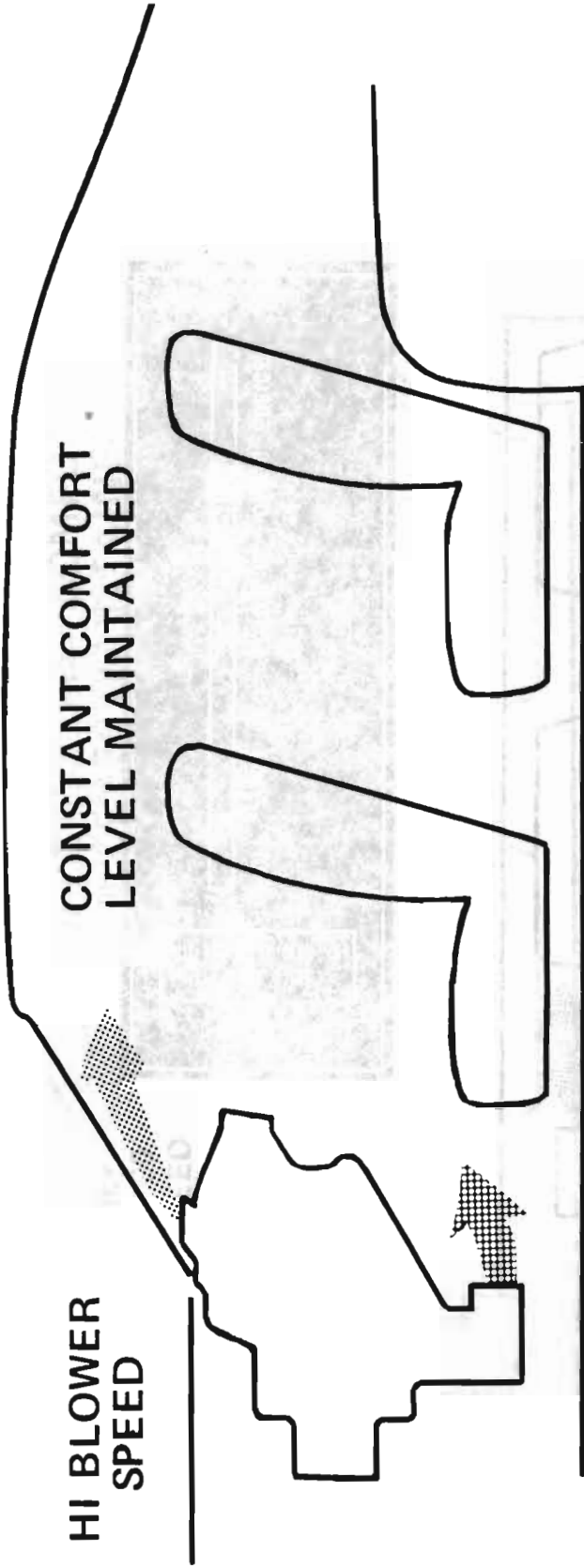

13-652

Figure 13-181 Comfort Level - Selector Lever in DEICE

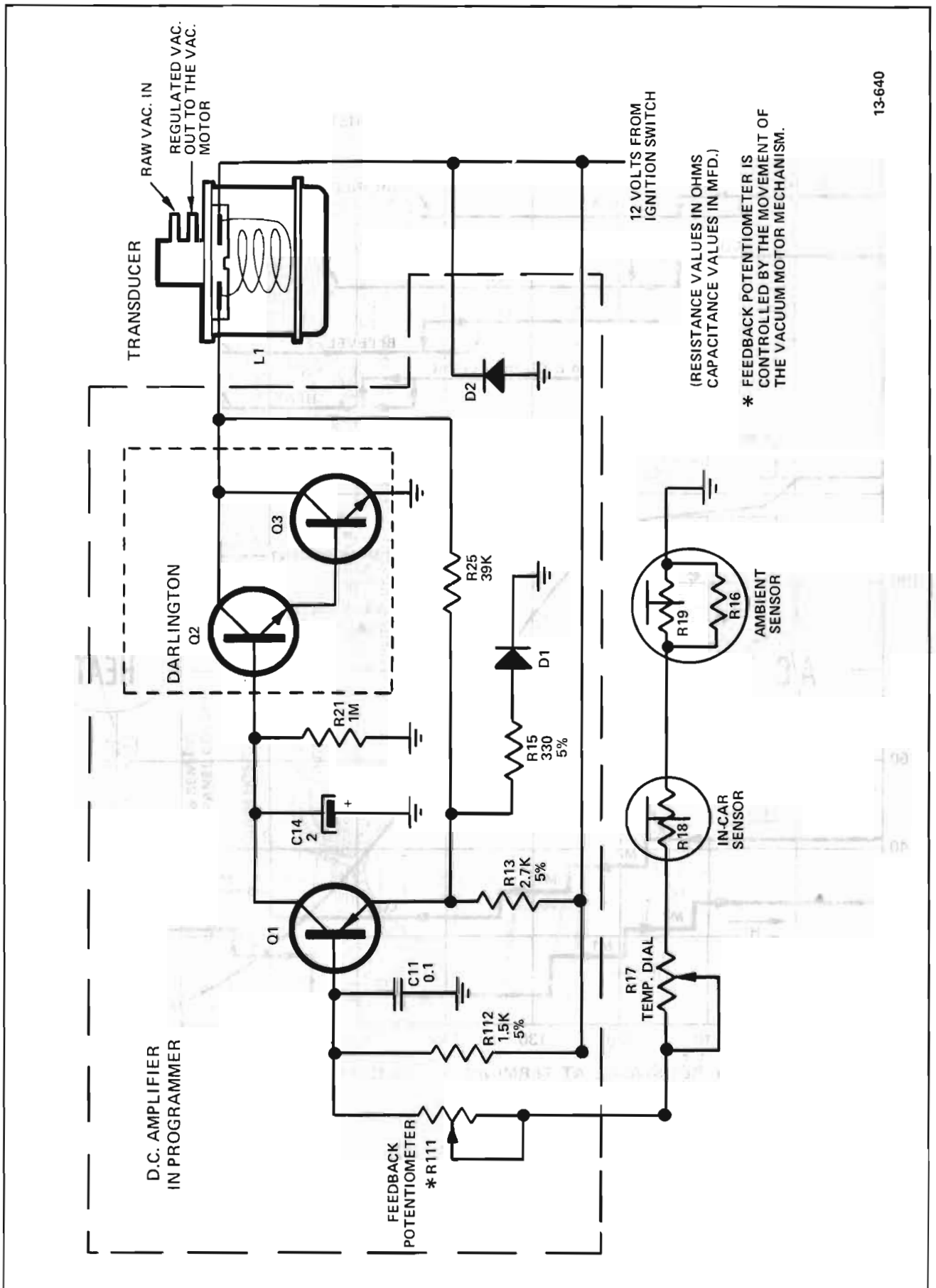

13-640

Figure 13-182 Amplifier Circuit Schematic

TYPICAL OPERATING CHARACTERISTICS OF PROGRAMMER

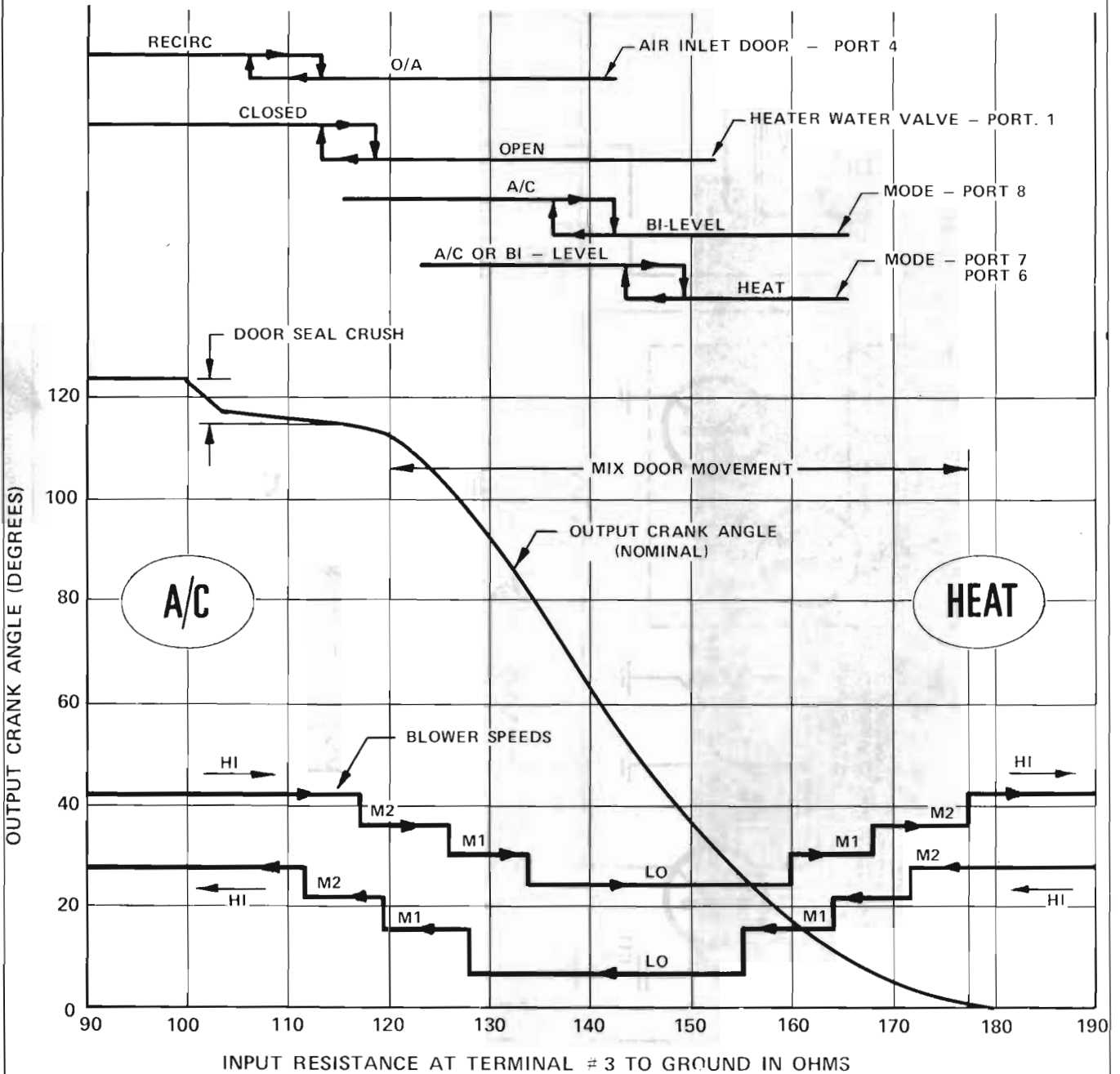
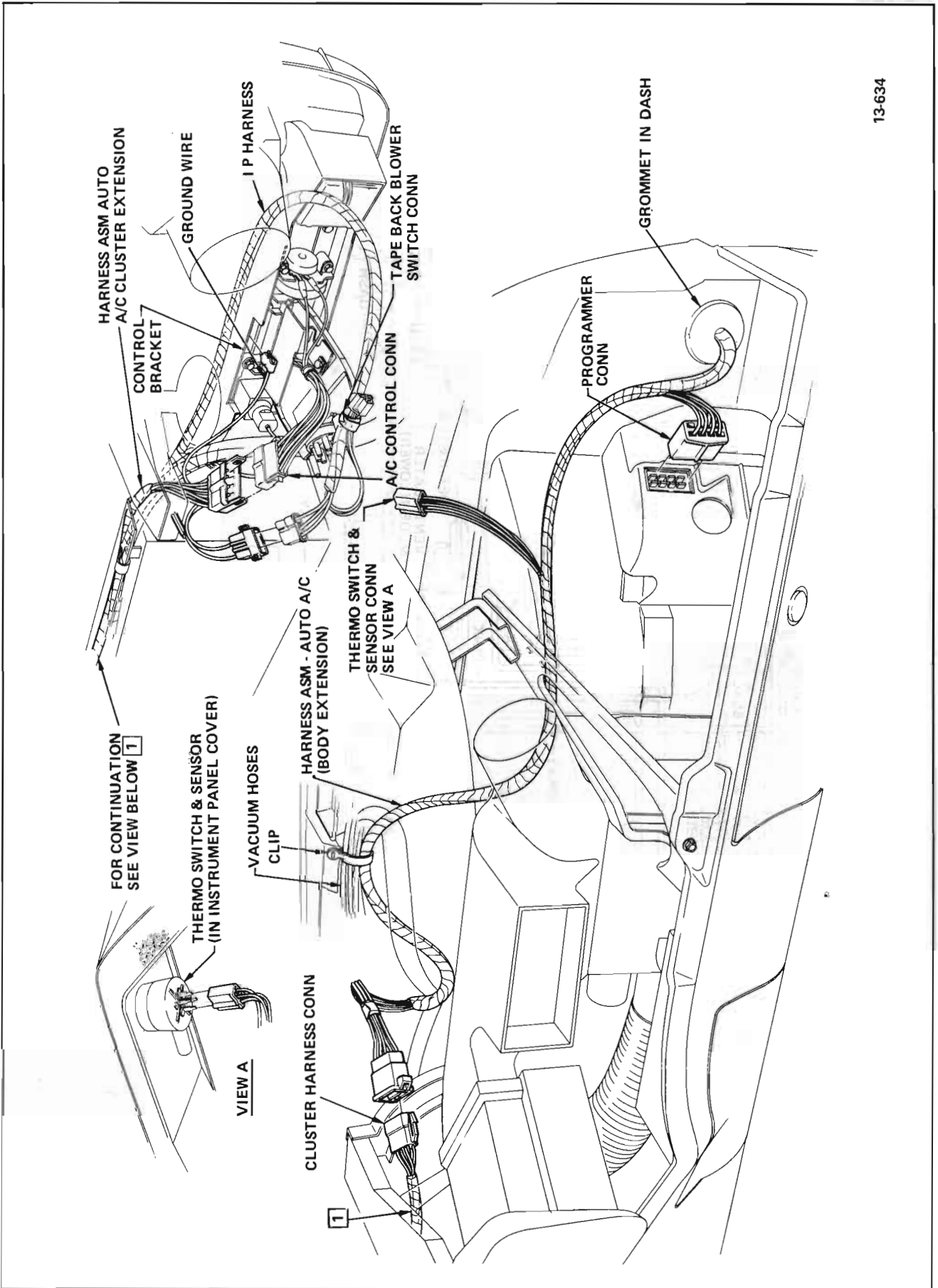

Figure 13-183 Typical Operating Characteristics of Programmer



13-634

Figure 13-184 45-46-48-49000 Series Instrument Panel Automatic A/C Wiring

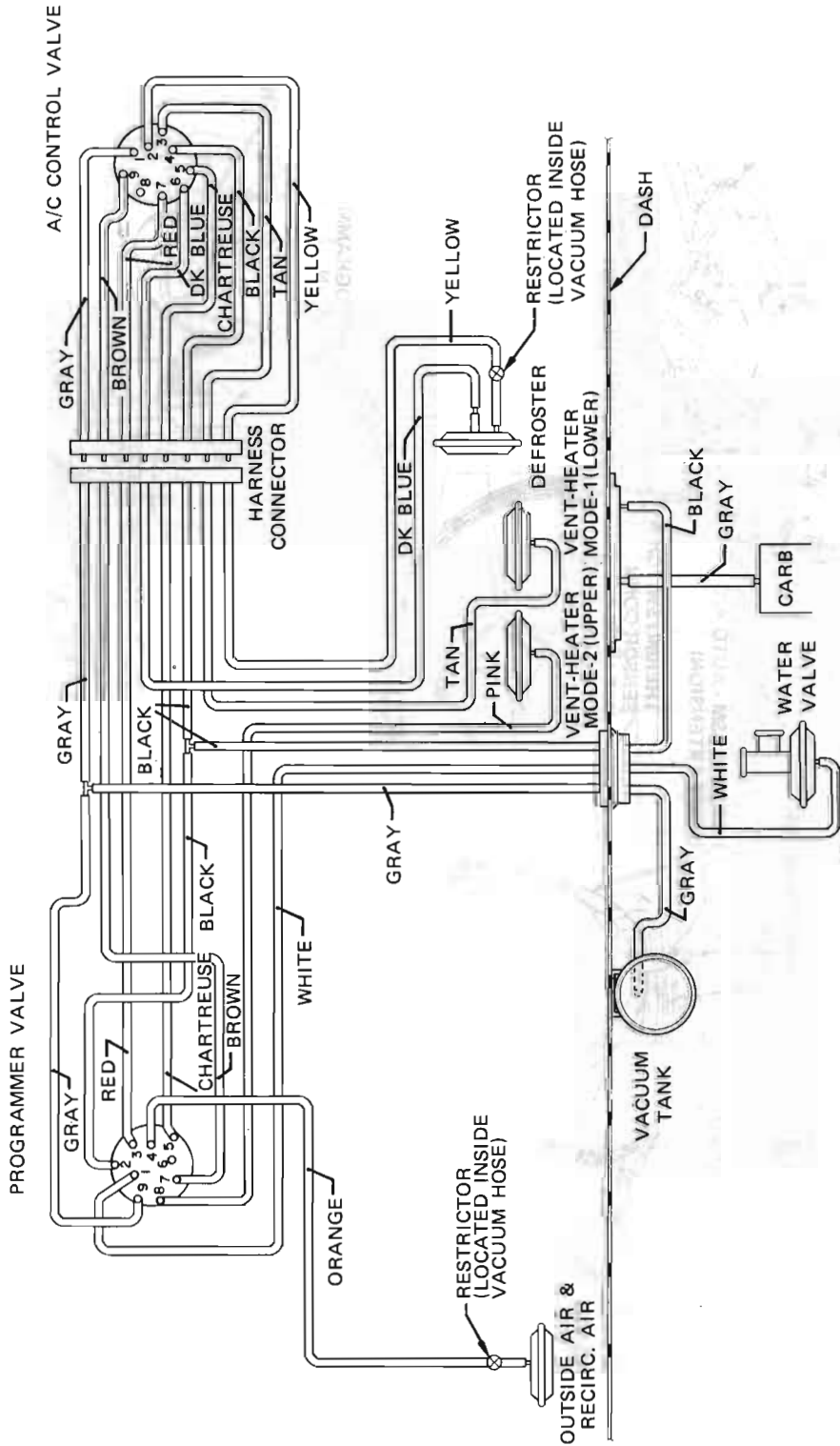
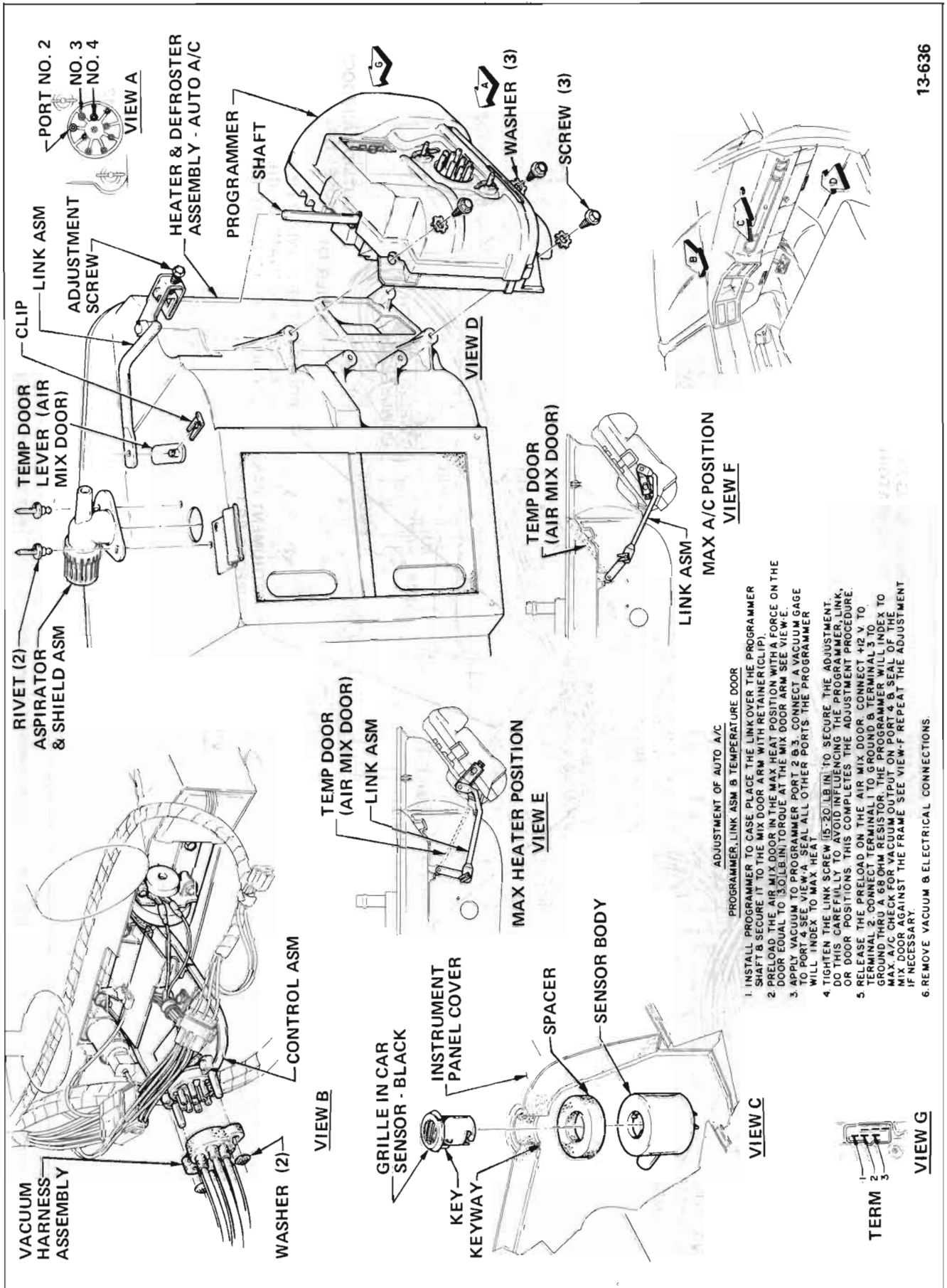
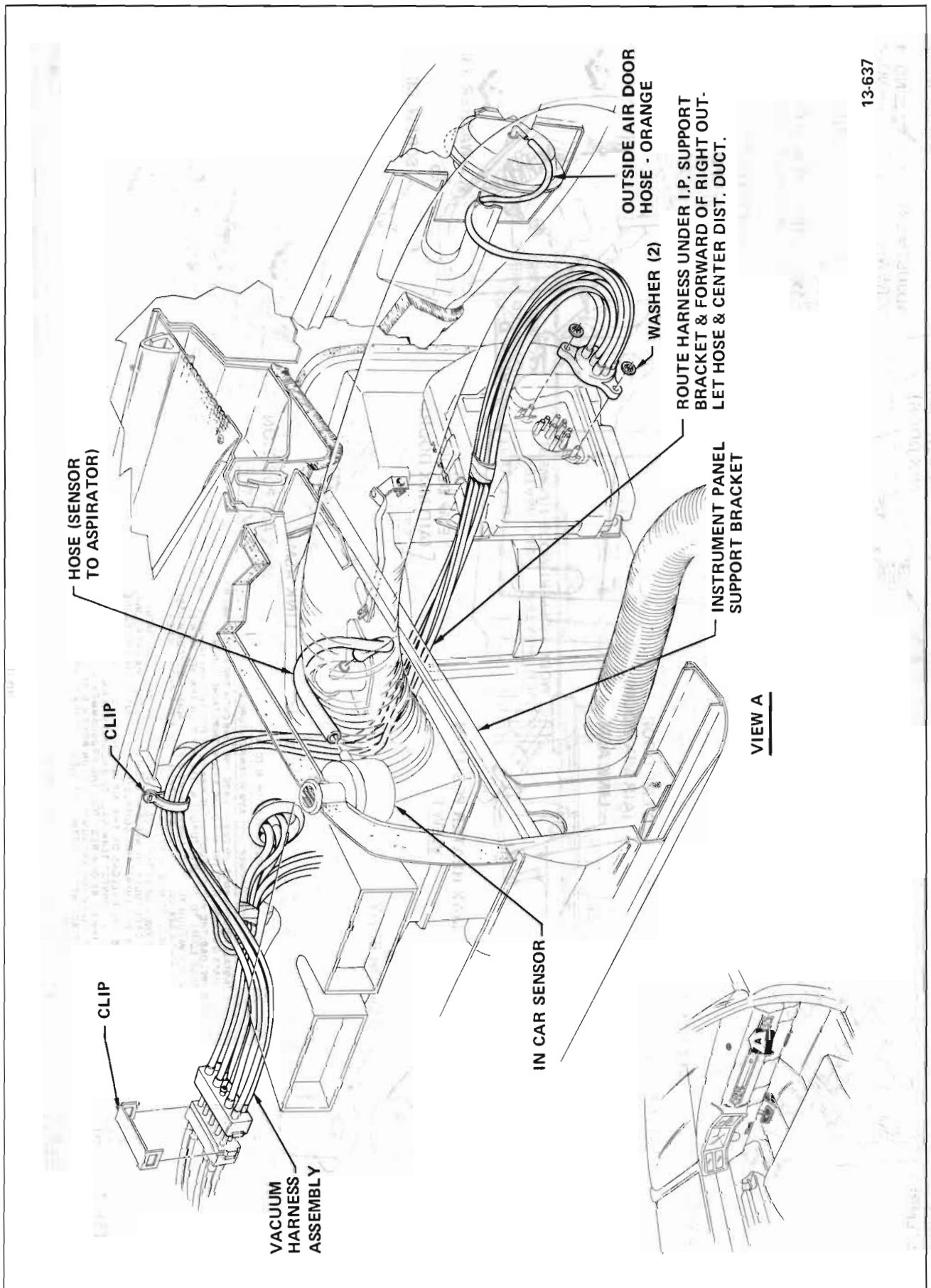

Figure 13-185 45-46-48-49000 Series Automatic A/C Vacuum Hose Schematic



13-636

Figure 13-186 45-46-48-49000 Series Automatic A/C Programmer Control and In-Car Sensor



13-637

Figure 13-187 45-46-48-49000 Series Automatic A/C Vacuum Hose Routing

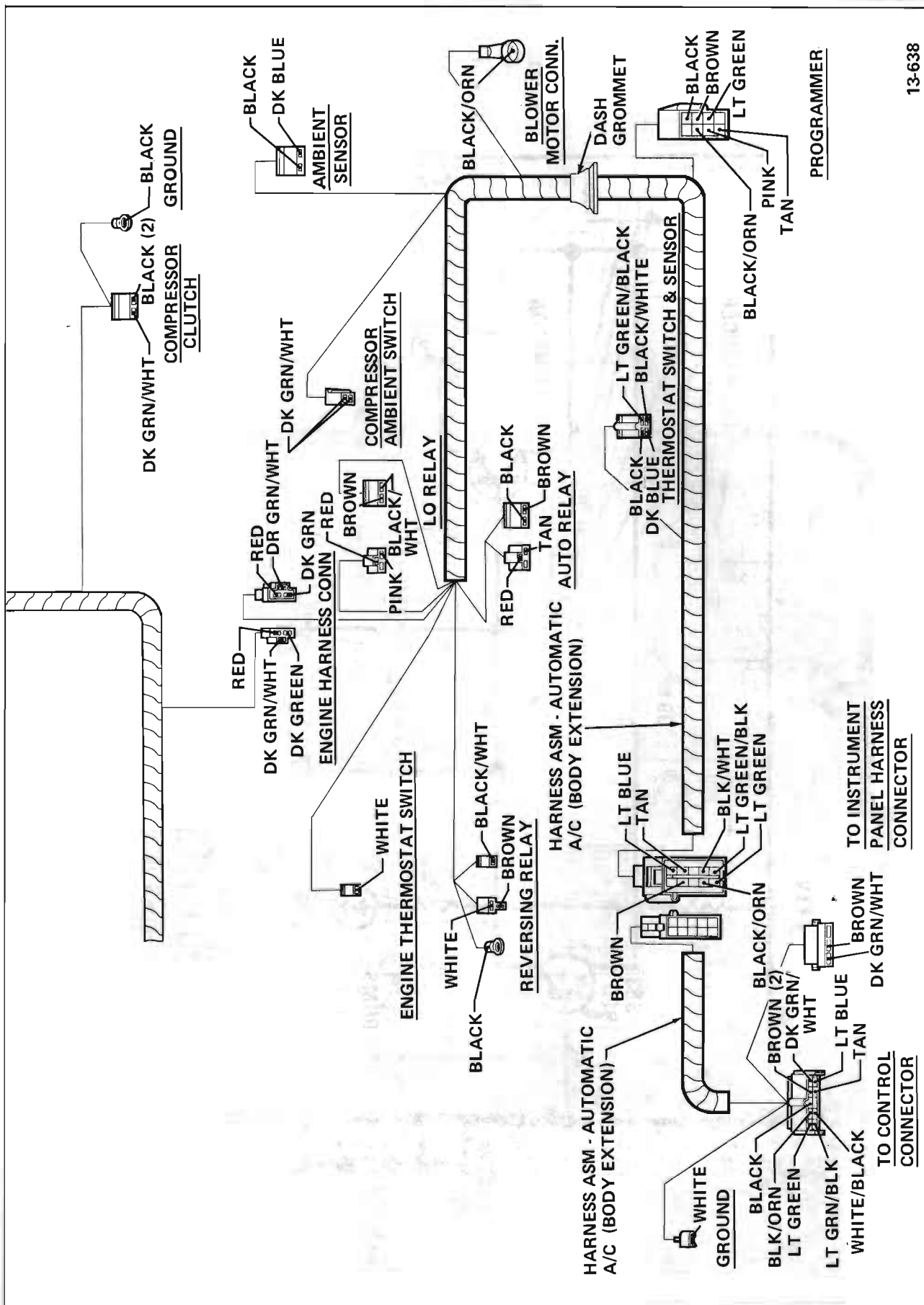

13-638

Figure 13-188 45-46-48-49000 Series Automatic A/C Wiring Harness Diagram

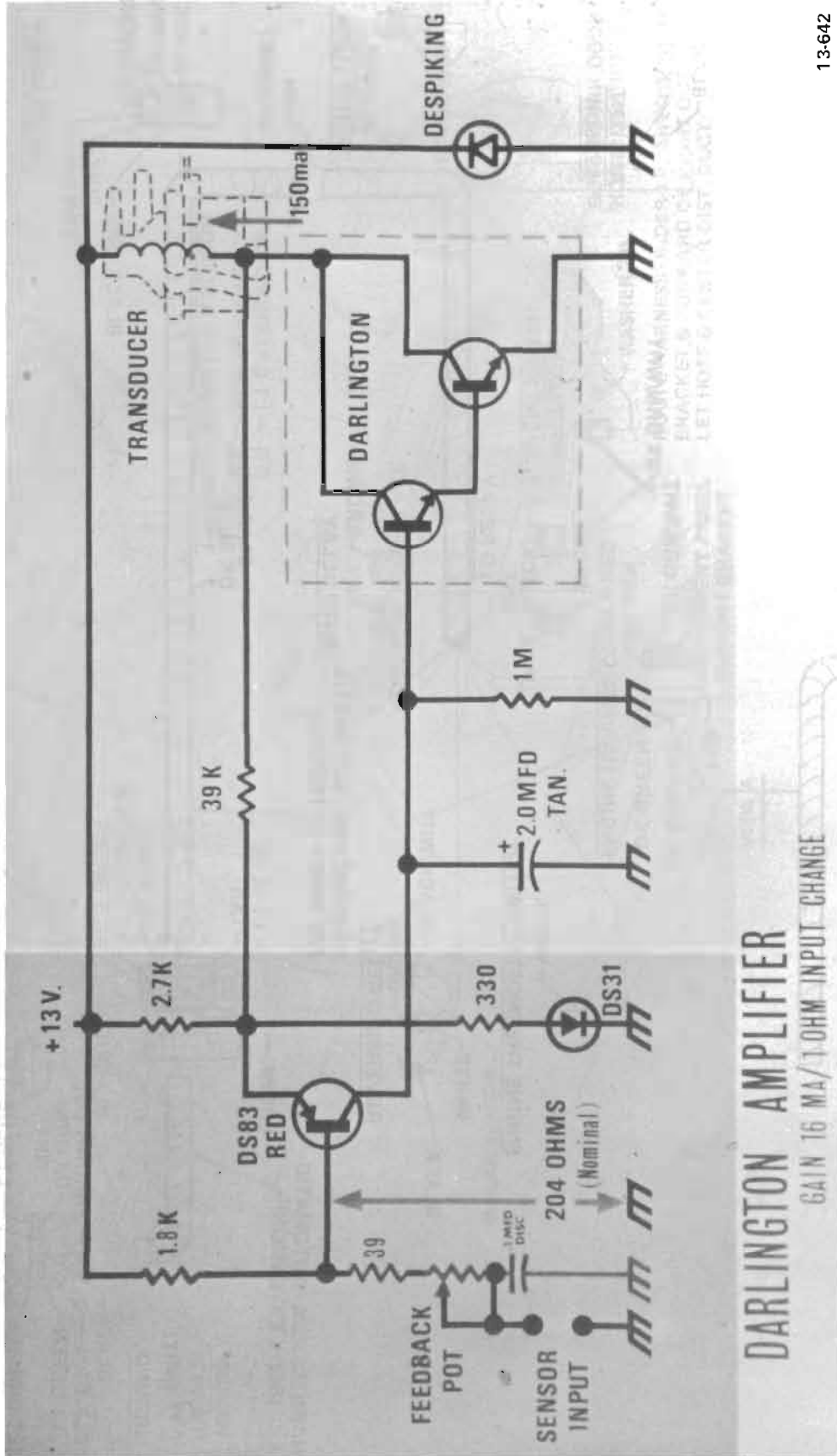

13-642

Figure 13-189 Darlington Amplifier

DELCO RADIO PROGRAMMER

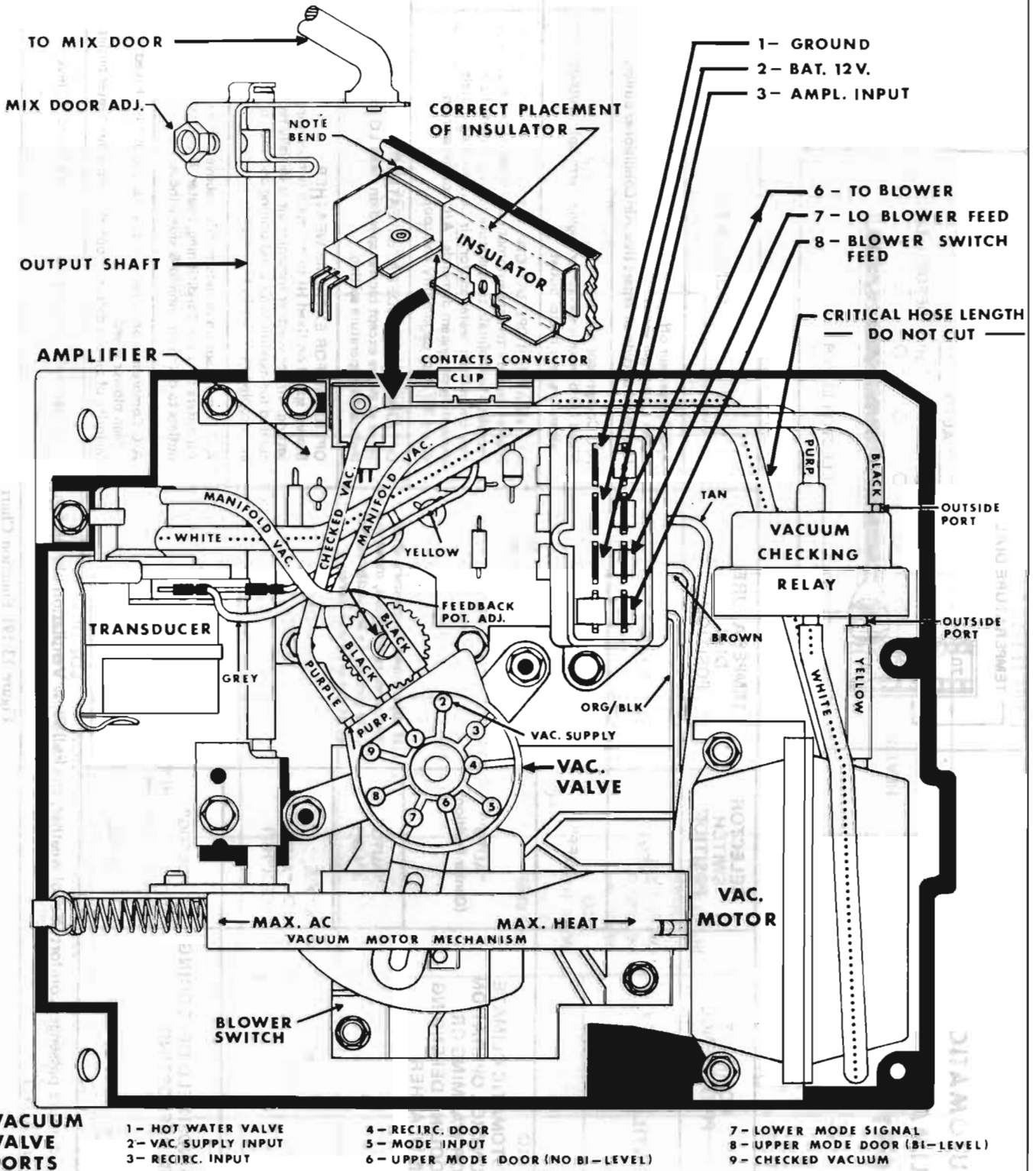
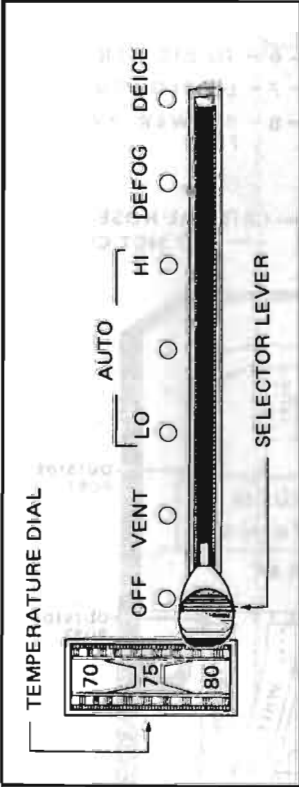

Figure 13-190 Delco Radio Programmer

AUTOMATIC CLIMATE CONTROL



COMFORT PREFERENCE	SELECTOR SWITCH POSITION	TEMPERATURE DIAL POSITION	COMMENTS
VENTILATION	"VENT"	No effect	A/C Compressor off Fixed LO blower speed Untreated outside air enters thru Air Conditioner outlets
	"OFF"		A/C Compressor off Fixed LO blower speed (after engine warm-up). Outside air enters thru heater outlet
AUTOMATIC CLIMATE CONTROL OPERATION FOR WARMING OR COOLING DEPENDING ON WEATHER	"AUTO" (Center Position)	Set between "70" & "80" to approximate temperature preference.	ALL WEATHER OPERATION Blower speeds alternate automatically from HI to LO as necessary to maintain temperature setting. Treated air may come from heater and/or Air Conditioning outlets depending on system demands. A/C compressor on above 35° F to dehumidify and cool.
	"AUTO" ("LO")	If adjustment is necessary after temperature stabilizes, move dial only slightly to avoid discomfort of extreme temperatures.	OPTIONAL FOR MODERATE WEATHER Same as above except blower speed on fixed LO to maintain temperature setting.
	"AUTO" ("HI")		OPTIONAL FOR EXTREME WEATHER Blower speed on fixed HI to maintain temperature setting. In hot weather incoming air is initially recirculated for maximum air conditioning and then outside air is cooled to maintain temperature setting.
WINDSHIELD DEFOGGING OR DEFROSTING	"DEFOG"		A/C Compressor on to dehumidify (above 35° F) Air enters thru Air Conditioning, heater, & defroster outlets to defog windshield & side windows.
	"DEICE"		A/C Compressor on to dehumidify (above 35° F) Fixed high blower speed. Majority of air out defroster outlets - some out heater outlet.

NOTE: To insure passenger comfort in cool weather, the Full Flow Ventilation blower fan will not start until engine warm-up with Selector lever at "OFF" or "AUTO"

Figure 13-191 Function Chart

LEVER	AIR INLET DOOR LOCATION	PROGRAMMER AND TEMP. DOOR	MODE DOORS POSITION	DEFROSTER DOOR POSITION	COMPRESSOR CLUTCH	WATER VALVE (NORMALLY OPEN)	BLOWER RELAYS	BLOWER SPEEDS
OFF		VARIES	HEATER	CLOSED	DE-ENERGIZED	EITHER	LOW RELAY CLOSED BY IN-CAR SWITCH OR BY ENGINE SWITCH OPENING WHICH CLOSSES HTR. DELAY RELAY	FIXED LOW
VENT	OUTSIDE AIR	FORCED TO MAX. A/C	A/C	BLEED POSITION AND WILL DELIVER SMALL AMOUNT OF AIR TO W/S IF IN HEATER OR BI-LEVEL MODE		SHUT-OFF	LOW RELAY IS CLOSED BY CONTROL HEAD SWITCH	
LO			EITHER HEATER BI-LEVEL OR A/C DEPENDING ON PROGRAMMER POSITION			USUALLY OPEN HOWEVER SHUT-OFF IF PROGRAMMER IS IN MAX. A/C POSITION	SAME AS CONTROL HEAD IN "OFF"	
AUTO		VARIES FROM MAX. HTR. TO MAX. A/C DEPENDING ON SENSOR STRING RESISTANCE			ENERGIZED IF ABOVE FREEZING		LOW AND AUTO RELAYS CLOSED BY IN-CAR SWITCH OR BY ENGINE SWITCH OPENING WHICH CLOSSES HEATER DELAY RELAY	VARIABLE BLOWER PROGRAM
HI	RECIRCULATE AIR WHEN PROGRAMMER IS IN MAX. A/C OTHERWISE OUTSIDE AIR		BI-LEVEL			OPEN		FIXED HIGH
DEFOG								VARIABLE BLOWER PROGRAM
DEICE			HEATER	FULL OPEN TO W/S			LOW AND AUTO RELAYS CLOSED BY CONTROL HEAD SWITCH	FIXED HIGH

13-644

Figure 13-192 Function Chart

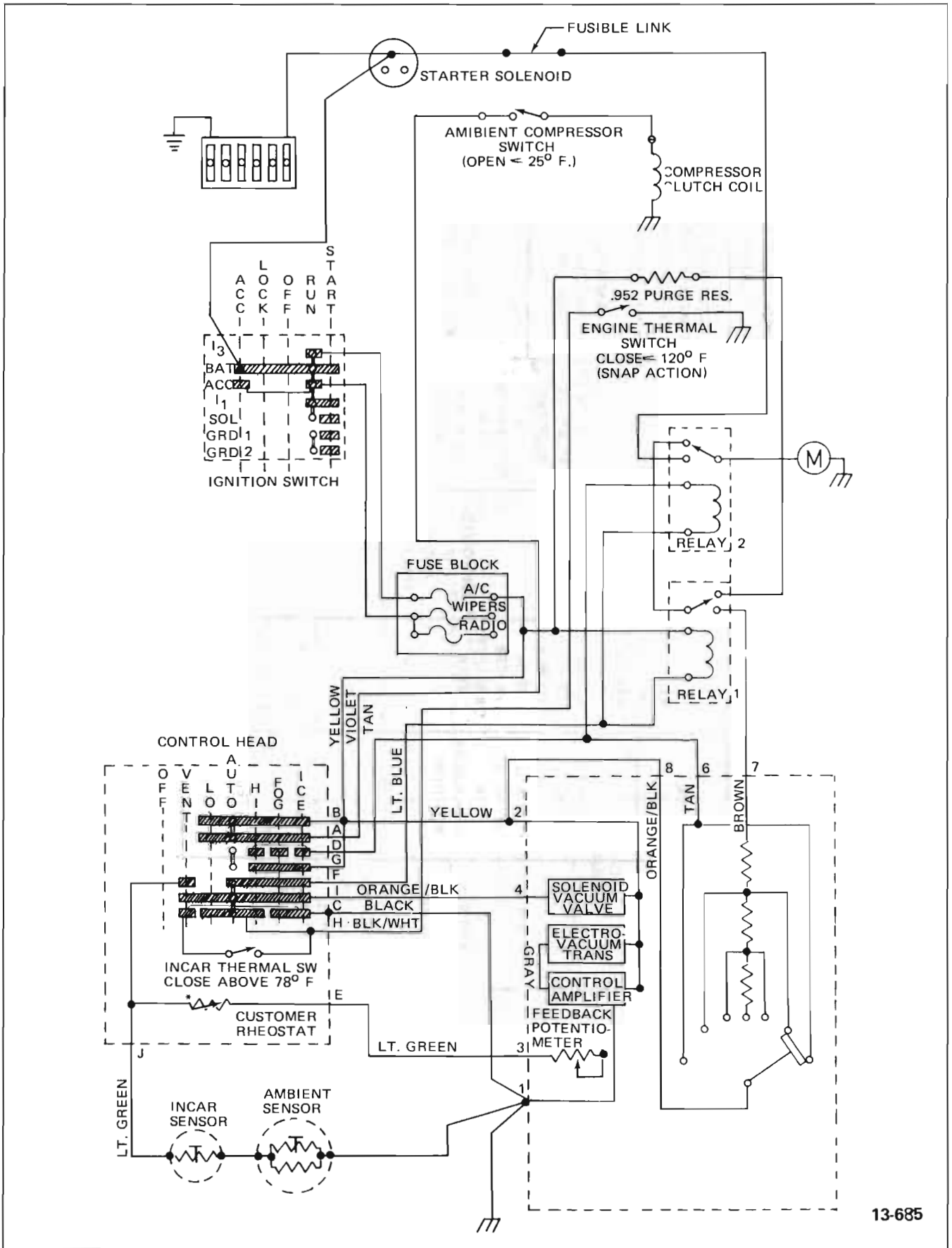

Figure 13-193 Automatic A/C Electrical Schematic