

# SECTION C

## Heater - Air Conditioner System 45-46-48-49000 Series

### CONTENTS

Division	Subject	Paragraph
I	TROUBLE DIAGNOSIS: Diagnosis Guide . . . . .	13-50
II	DESCRIPTION AND OPERATION: Basic Description of System Operation . . . . . Electrical System Operation . . . . . Vacuum System Operation . . . . .	13-51 13-52 13-53
III	ADJUSTMENTS AND MINOR SERVICE: Adjustment of Control Wire Assembly . . . . .	13-54
IV	REMOVAL AND INSTALLATION: Removal and Installation of Control Assembly . . . . . Removal and Installation of Blower Motor and Air Inlet Assembly . . . . . Removal and Installation of Heater Assembly or Heater Core . . . . .	13-55 13-56 13-57
V	OVERHAUL AND MAJOR SERVICE: (Not Applicable)	-
VI	SPECIFICATIONS: (Not Applicable)	-

13C-1

## DIVISION I

LO Blower Only

### TROUBLE DIAGNOSIS

*Possible Cause*

#### 13-50 TROUBLE DIAGNOSIS GUIDE

##### Blower Inoperative

Disconnected plug at control head to body extension harness.

**No LO Blower in OFF, VENT, and LO Positions**

##### *Possible Causes*

*Possible Causes*

Disconnected, loose, or corroded blower ground wire.

Disconnected plug at the lo relay.

Disconnected feed wire.

Defective relay.

Defective blower.

**Immediate LO Blower - Car Start-Up**

Defective fuse.

*Possible Causes*

Disconnected plug at engine thermal switch.

Defective engine thermal switch.

Defective heater delay relay.

**LO Blower Inoperative All Positions**

*Possible Cause*

Grounded wire or defective engine thermal switch.

**Temperature of Discharge Air Too Hot or Too Cool**

*Possible Cause*

Misadjusted temperature door linkage.

**Insufficient Heat**

*Possible Causes*

Misadjusted temperature door linkage.

Defective water valve.

Defective engine thermostat.

Low coolant.

**Excessive Temperature Difference at Outlets Bi-Level Operation (Left Outlet Warmer Than Center)**

*Possible Cause*

Vacuum lines switched at upper and lower mode door diaphragms.

**Partial Air Flow to Windshield in DEICE and No Air Flow to Windshield in DEFOG Position**

*Possible Cause*

Vacuum lines to defroster (dual) diaphragm switched.

**NOTE:** Normal "DEFOG" operation has a delay before door opens.

**No Air Flow to Windshield in Either DEFOG or DEICE Position**

*Possible Causes*

Either vacuum line to defroster diaphragm disconnected.

Leaking dual diaphragm.

## DIVISION II

### DESCRIPTION AND OPERATION

#### 13-51 BASIC DESCRIPTION OF SYSTEM OPERATION

##### OFF POSITION

The 1971 Climate Control System is completely "shut-off" when the ignition switch of the car is in the "OFF" position. However, when the ignition switch is turned on, the electrical circuit to the Climate Control system is completed and the "LO" blower will come on after the engine coolant reaches 120 degrees F.

##### A/C POSITION

The compressor will run at temperatures above 32 degrees F. Cooled conditioned air will flow out of all six outlets, and in "MAX" cold, recirculated air at "HI" blower speed will occur automatically until a warmed temperature is selected.

**CAUTION:** After passenger comfort is obtained, move the temperature lever to the right of the detent for normal air conditioning.

##### VENT POSITION (TEMPERATURE LEVER IN MAX COLD)

The blower will come on in "LO" automatically after the engine water temperature reaches 120 degrees F, and outside air is distributed into the passenger compartment through the A/C and heater outlets. The blower will run in two (2) "MED" speeds or "HI", immediately, regardless of engine coolant temperature.

##### HEAT POSITION (TEMPERATURE LEVER IN MID RANGE)

The blower will come on in "LO" automatically after the engine coolant temperature reaches 120 degrees F., and air is distributed into the passenger compartment through the heater and through defroster ducts after 30 to 60 seconds. The blower will run in two (2) "MED" speeds or "HI", immediately, regardless of engine coolant temperature.

##### DEFOG POSITION (TEMPERATURE LEVER IN MID RANGE)

The blower will come on in "LO" automatically after the engine water temperature reaches 120 degrees F., and the A/C compressor is running to provide dehumidified air flow from the A/C, heater, and defroster outlets. Air is bled through the defroster outlets after a 30 to 60 second delay. The blower will run in two (2) "MED" or "HI", immediately, regardless of engine coolant temperature.

**DEICE POSITION (TEMPERATURE LEVER IN MAX HOT)**

The blower will come on in "LO" automatically after the engine water temperature reaches 120 degrees F., and the A/C compressor will run to dehumidify air if temperature is above 32 degrees F. A majority of air will flow out of the defroster outlets with some air flowing out the heater outlet. The blower will run in two (2) "MED" speeds or "HI", immediately, regardless of engine coolant temperature.

**13-52 ELECTRICAL SYSTEM OPERATION****OFF POSITION**

When the selector lever is in the "OFF" position, the system is locked in "LO Blower" operation. When the fan switch is in "LO" position, the ignition switch in the "RUN" position and the engine thermal switch is open, the heater delay relay is closed. The engine thermal switch opens whenever the engine coolant temperature reaches 120 degrees F. When the engine thermal switch opens, the heater delay relay snaps closed and allows current to flow to the blower motor.

**A/C POSITION**

With the ignition switch is "RUN", the selector lever in the "A/C" position, and the temperature lever at MAX "COLD", the fan is in fixed "HI" blower regardless of fan switch position. In MAX "COLD" position also, the recirculate door and water valve are actuated through a vacuum switch on the dash control. Moving the temperature lever from the MAX "COLD" to the detent position (approximately 3/8 inch travel right) causes the recirculate override switch to open, and causing blower speed to be controlled from the fan switch. The detent position will open the hot water valve. Also, from this detent position to MAX "HOT" position, the temperature door is modulated to provide greater amounts of air to be diverted through the heater core.

The compressor will run above 32 degrees F. which is controlled by the opening (below 32 degrees F.) and closing (above 32 degrees F.) of the ambient switch.

**VENT POSITION**

With the ignition switch in "RUN" and the selector lever in the "VENT" position, the fan is controlled by the fan switch. Compressor is shut off.

The engine thermal switch opens when the engine coolant temperature reaches 120 degrees F. and allows the delay relay to snap closed allowing current to flow to the blower motor. If fan switch is in "MED" or "HI", the blower will run regardless of engine coolant temperature, because the delay relay and thermal switch are both by-passed.

**HEAT POSITION**

With the ignition switch in "RUN" and the selector lever

in the "HEAT" position, the fan speed is controlled by the fan switch.

The engine thermal switch opens when the engine coolant temperature reaches 120 degrees F., and allows the delay relay to snap closed allowing current to flow to the blower motor or "LO" fan speed.

If the fan switch is in two (2) "MED" speeds or "HI", the blower will run, regardless of engine coolant temperature because the delay relay and thermal switch are both by-passed.

**DEFOG POSITION**

With the ignition switch in "RUN" and the selector lever in the "DEFOG" position, the fan is locked in "LO" blower operation when the fan switch is in the "LO" position.

The compressor runs in this position above 32 degrees F. which is controlled by the opening (below 32 degrees F.) and closing (above 32 degrees F.) of the ambient switch, to provide dehumidified air regardless of temperature lever position.

The engine thermal switch opens when the engine coolant temperature reaches 120 degrees F., and allows the delay relay to snap closed allowing current to flow to the blower motor.

If the fan switch is in "MED" or "HI", the blower will run regardless of engine coolant temperature because the delay relay and thermal switch are both by-passed.

**DEICE POSITION**

With the ignition switch in "RUN" and the selector lever in the "DEICE" position, the fan is locked in "LO" blower operation when the fan switch is in the "LO" position.

The compressor runs in this position above 32 degrees F., which is controlled by the opening (below 32 degrees F.) and closing (above 32 degrees F.) of the ambient switch, to provide dehumidified air regardless of temperature lever position.

The engine thermal switch opens when the engine coolant temperature reaches 120 degrees F., and allows the delay relay to snap closed allowing current to flow to the blower motor.

If the fan switch is in "MED" or "HI", the blower will run regardless of engine coolant temperature because the delay relay and thermal switch are both by-passed.

**13-53 VACUUM SYSTEM OPERATION****OFF POSITION (TEMPERATURE LEVER IN MAX COLD)**

With the selector lever in the "OFF" position and the

engine running, the system is turned on whenever the thermal switch opens. Air flows from the heater outlets at "LO" blower speed. Vacuum is applied to the water valve holding the valve closed. See Figure 13-99.

#### A/C POSITION (TEMPERATURE LEVER IN MAX COLD)

With the selector lever in the "A/C" position and the temperature lever in the max "COLD" position, vacuum is applied to the recirc door diaphragm closing the door to the outside air causing recirculation of most of the air while introducing some outside air into the passenger compartment. Vacuum is also applied to the upper and lower heater door diaphragms causing the doors to open, allowing air to flow from the A/C outlets. Vacuum is applied to the water valve holding the valve closed. See Figure 13-100.

**CAUTION:** After passenger comfort is obtained, move the temperature lever to the right of the detent for normal air conditioning. See Figure 13-101.

#### VENT POSITION (TEMPERATURE LEVER IN MAX COLD)

Air is drawn in through the outside air door and is distributed from the A/C and heater outlets at "LO" blower speed. Vacuum is applied to the lower mode door diaphragm which causes it to open and directs a portion of the air to the A/C outlets. No vacuum is applied to the upper mode door directing the remaining air through the heater outlets. Vacuum is applied to the water valve holding the valve closed.

#### HEAT POSITION (TEMPERATURE LEVER IN MID RANGE)

In this position, outside air is drawn in through the outside air door and then is divided by the air mix door. Part of the air passes through the heater core to be warmed while the rest of the air by-passes the core. The air is then mixed and distributed into the passenger compartment through the heater and defroster outlets.

Vacuum is applied to the defroster door diaphragm and is restricted to delay partial bleed to the windshield for 30-60 seconds. No vacuum is applied to the upper and lower mode door diaphragm so the majority of the air is directed through the heater outlets. No vacuum is applied to the water valve allowing the valve to open. See Figure 13-103.

#### DEFOG POSITION (TEMPERATURE LEVER IN MID RANGE POSITION)

In this position outside air is drawn in through the outside air door and then is divided by the mix door. Part of the air passes through the heater core to be warmed while the rest of the air bypasses the core. The incoming air is dehumidified before it reaches the mix-door since the A/C compressor is running if the outside temperature is above 32 degrees F. The air is then mixed and distributed into the passenger compartment through the heater, A/C, and defroster outlets. Defroster bleed air is delayed 30 to 60

seconds. Vacuum is applied to the lower mode door diaphragm opening the door, allowing a portion of the air to flow out of the A/C outlets while no vacuum is applied to the upper mode door diaphragm allowing air to flow from the heater outlets. Vacuum is applied to the defroster door diaphragm but is restricted not to allow the door to open only partially. No vacuum is applied to the water valve allowing the valve to open. See Figure 13-104.

#### DEICE POSITION (TEMPERATURE LEVER IS MAX HOT POSITION)

In this position outside air is drawn in through the outside air door and then is directed through the heater core. The incoming air is dehumidified before it reaches the heater core since the A/C compressor is running if the outside temperature is above 32 degrees F. Vacuum is applied to the defroster door diaphragm causing the door to open, directing the majority of the air to flow out of the defroster outlets. A small portion of air will come out of the heater outlets since no vacuum is applied to the upper and lower mode doors. No vacuum is applied to the water valve allowing the valve to open.

## DIVISION III

### ADJUSTMENTS AND MINOR SERVICE

#### 13-54 ADJUSTMENT OF CONTROL WIRE ASSEMBLY

1. Assemble control wire to control assembly.
2. Secure temperature wire to temperature control valve.
3. Adjust control cable so that 1/16" to 1/8" springback is obtained in the "Hot" position.

## DIVISION IV

### REMOVAL AND INSTALLATION

#### 13-55 REMOVAL AND INSTALLATION OF CONTROL

##### ASSEMBLY

##### a. Removal

1. Disconnect battery.
2. Remove headlight switch.
3. Remove lower dash trim.
4. Remove two (2) see-lights from trim plate.
5. Remove four (4) screws from control face.

6. Remove one (1) screw from under dash which connects heater control to instrument panel forward support.

7. Disconnect vacuum, electrical connectors, and Bowden wires.

8. Remove control assembly.

#### b. Installation

1. Install control assembly reverse of removal procedure.

2. Adjust control cable so that 1/16" to 1/8" springback is obtained in the "Hot" position.

### 13-56 REMOVAL AND INSTALLATION OF BLOWER MOTOR AND AIR INLET ASSEMBLY

#### a. Removal

1. Support hood and loosen hood hinge from extension and plate assembly.

2. Remove extension and plate assembly.

3. (Blower Motor Only) Disconnect blower Motor wire. Remove screws securing blower motor to air inlet assembly.

(Blower Motor and Air Inlet Assembly) Disconnect blower motor wire. Remove four (4) nuts and two (2) screws securing blower and air inlet assembly to dash.

4. Disconnect electrical connector from blower motor resistor.

#### Installation

Install blower motor or blower motor and air inlet assembly reverse of removal procedures and seal along mating surfaces between dash and air inlet assembly.

### 13-57 REMOVAL AND INSTALLATION OF HEATER ASSEMBLY OR HEATER CORE

#### a. Removal

1. Drain radiator and disconnect heater inlet and outlet hoses at dash.

2. Disconnect control wires from defroster door and vacuum hose diverter door actuator diaphragm and control cable from temperature door lever.

3. Remove four (4) nuts securing heater assembly to dash.

4. Remove screw securing defroster outlet tab to heater assembly.

5. Work heater assembly rearward until studs clear dash and remove heater assembly.

#### b. Installation

1. Install heater assembly reverse of removal procedures and seal along mating surfaces between dash and heater assembly.

2. Adjust control cable so that 1/16" to 1/8" springback is obtained in the "Hot" position.

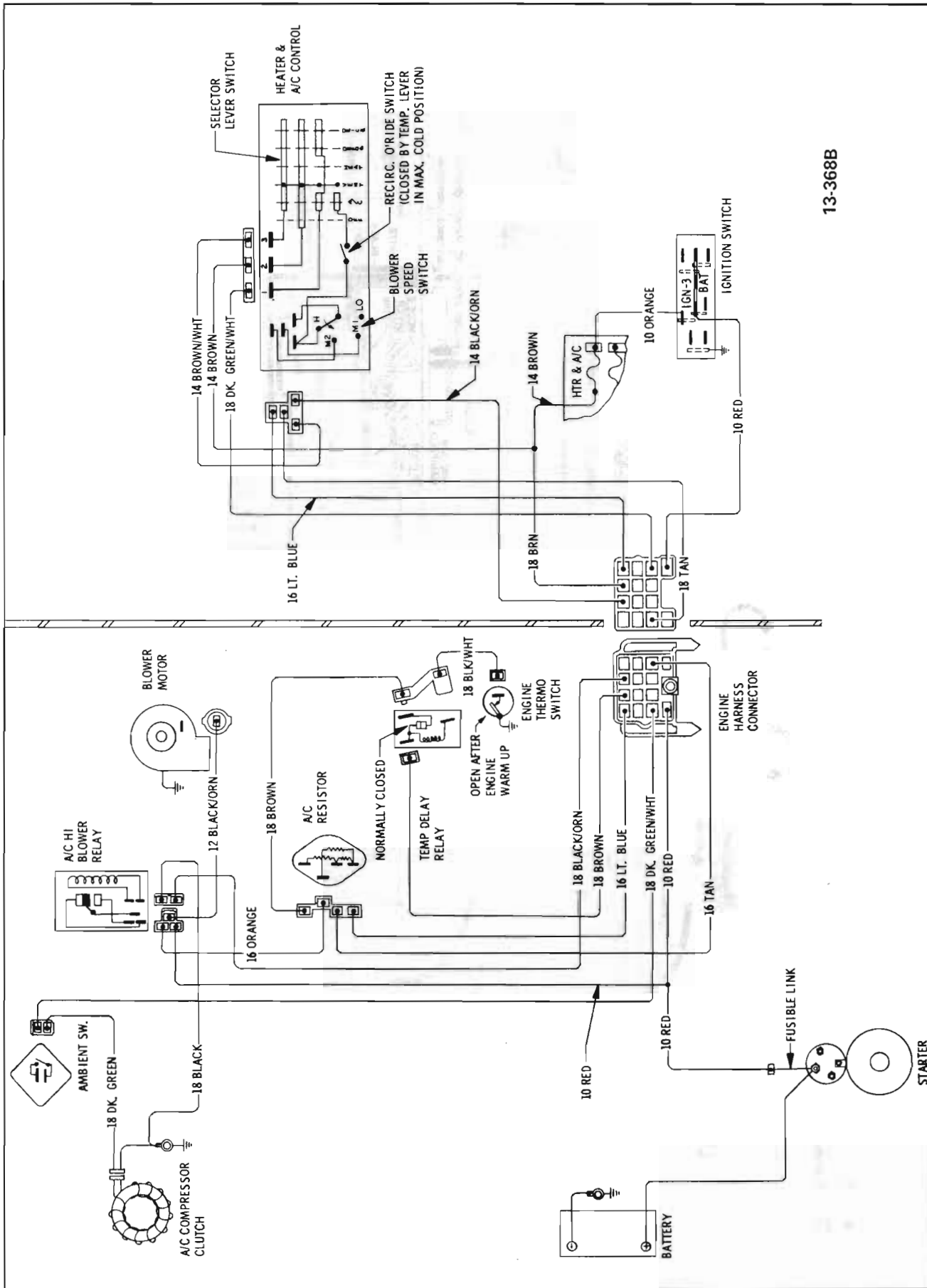

13-368B

Figure 13-98 45-46-48-49000 Series Heater - Air Conditioner Wiring Diagram

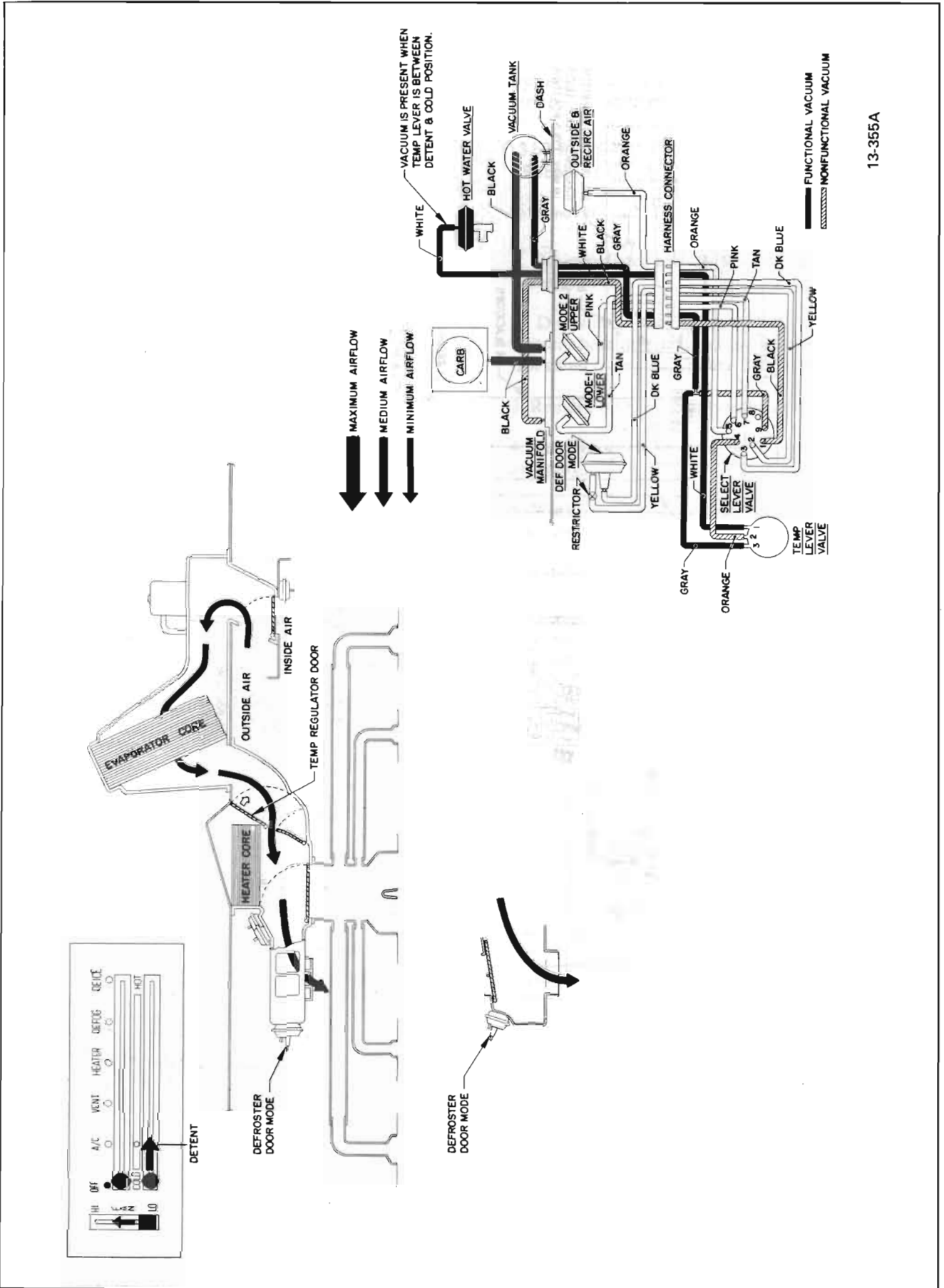

13-355A

Figure 13-99 45-46-48-49000 Series Control Position, Vacuum Circuits, and Air Flow During OFF Mode

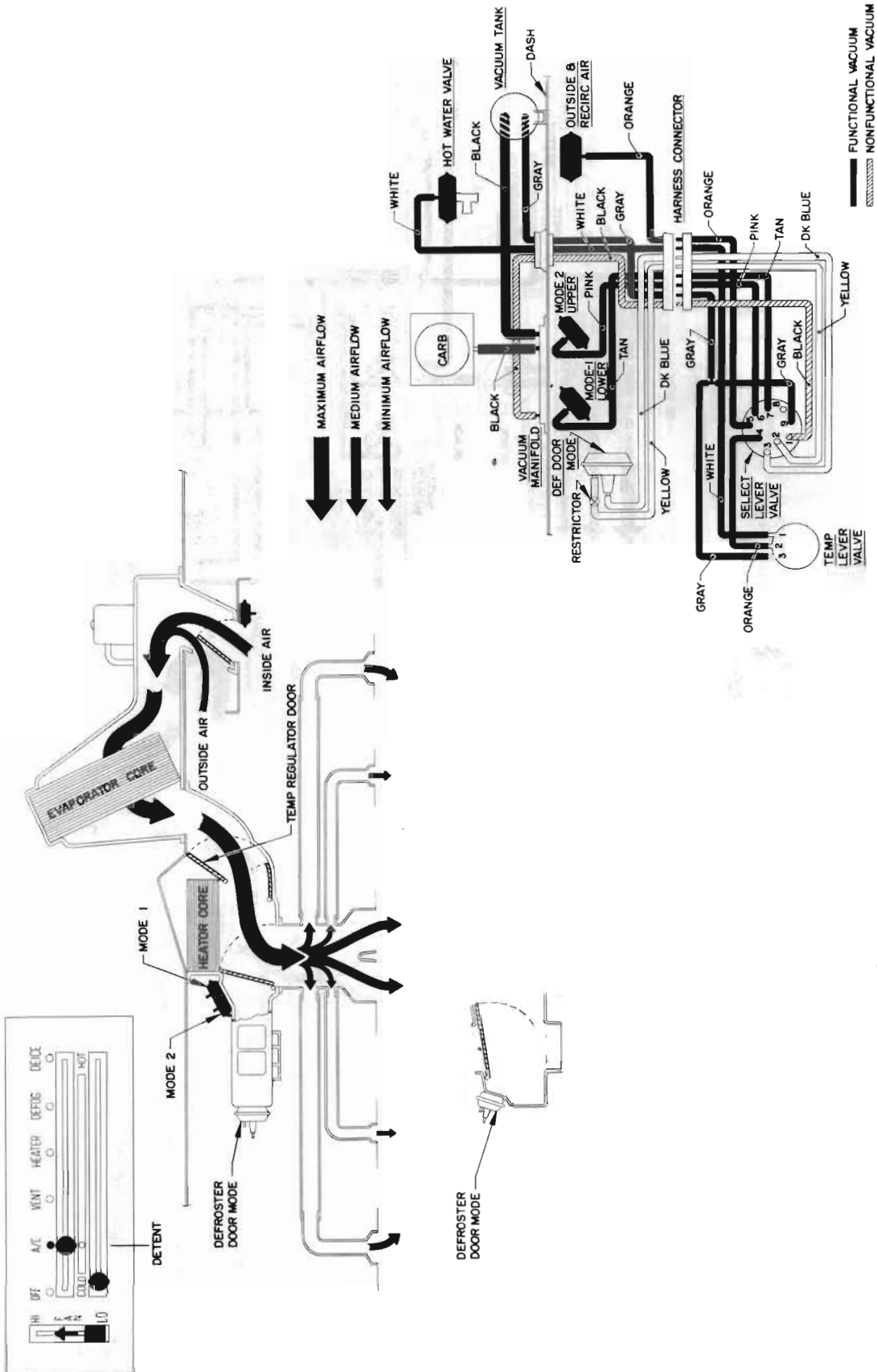

13-356A

Figure 13-100 45-46-48-49000 Series Control Position, Vacuum Circuits, and Air Flow During A/C Mode - Recirc



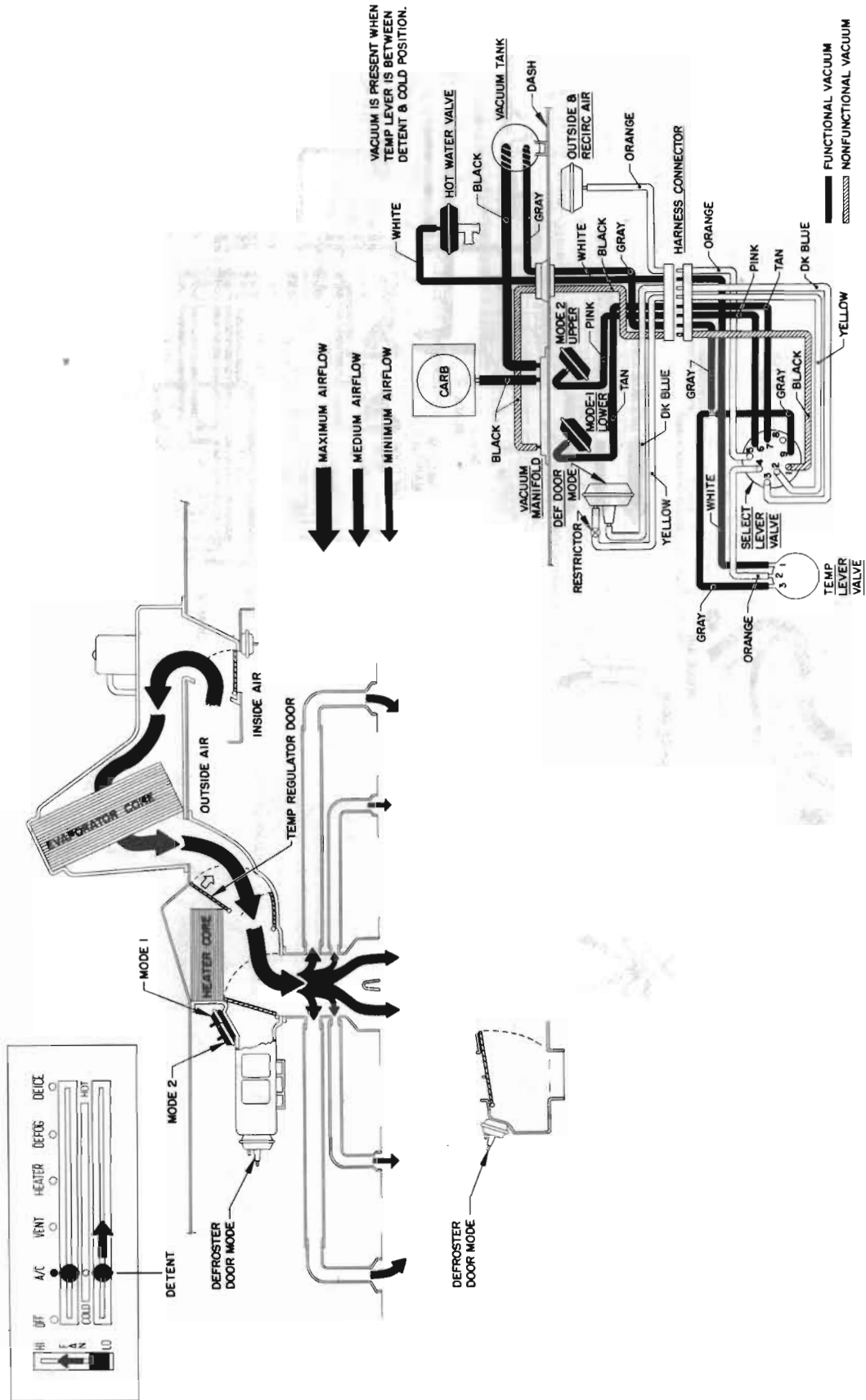

13-357A

Figure 13-101 45-46-48-49000 Series Control Position, Vacuum Circuits, and Air Flow During A/C Mode

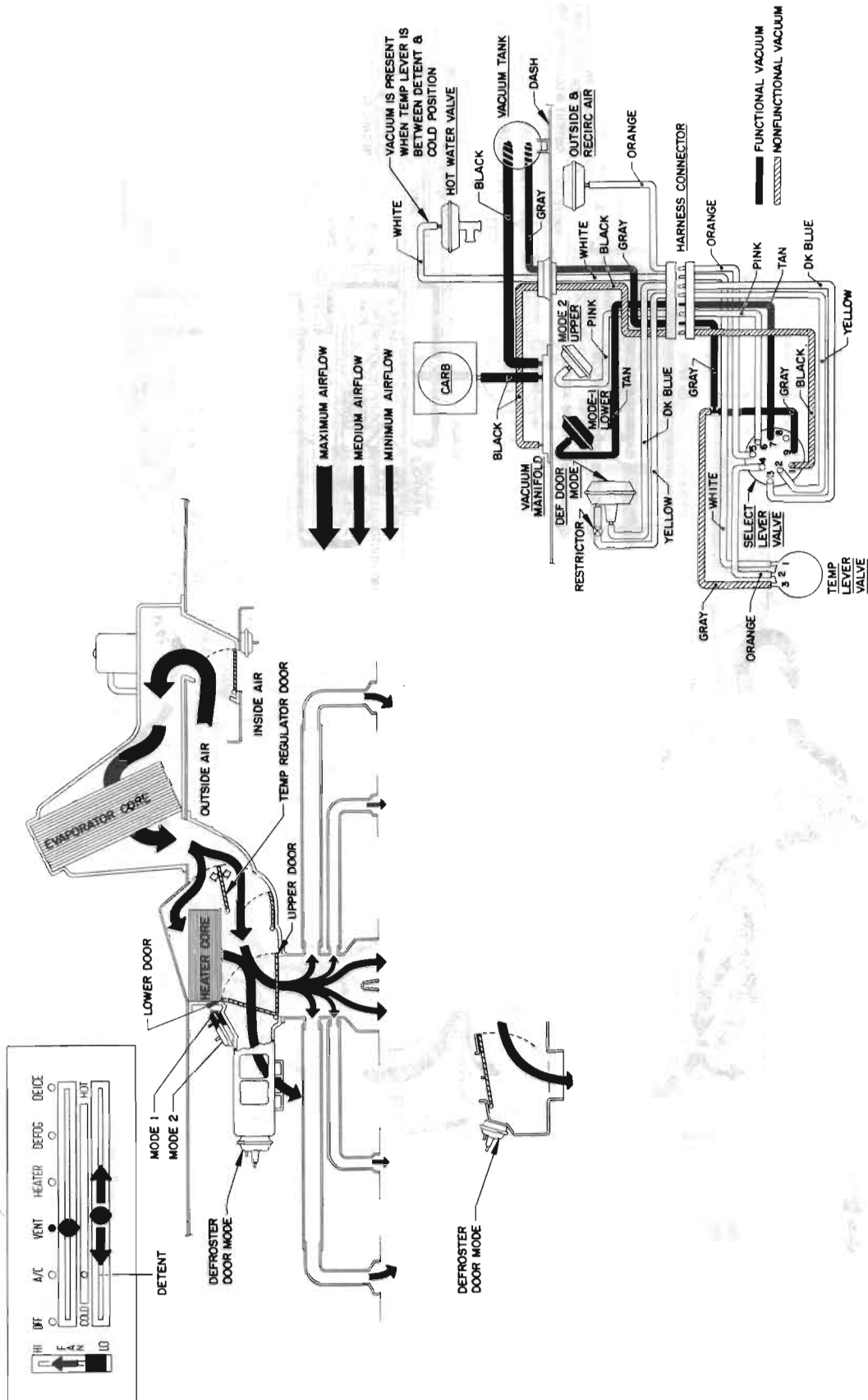

13-358A

Figure 13-102 45-46-48-49000 Series Control Position, Vacuum Circuits, and Air Flow During VENT Mode

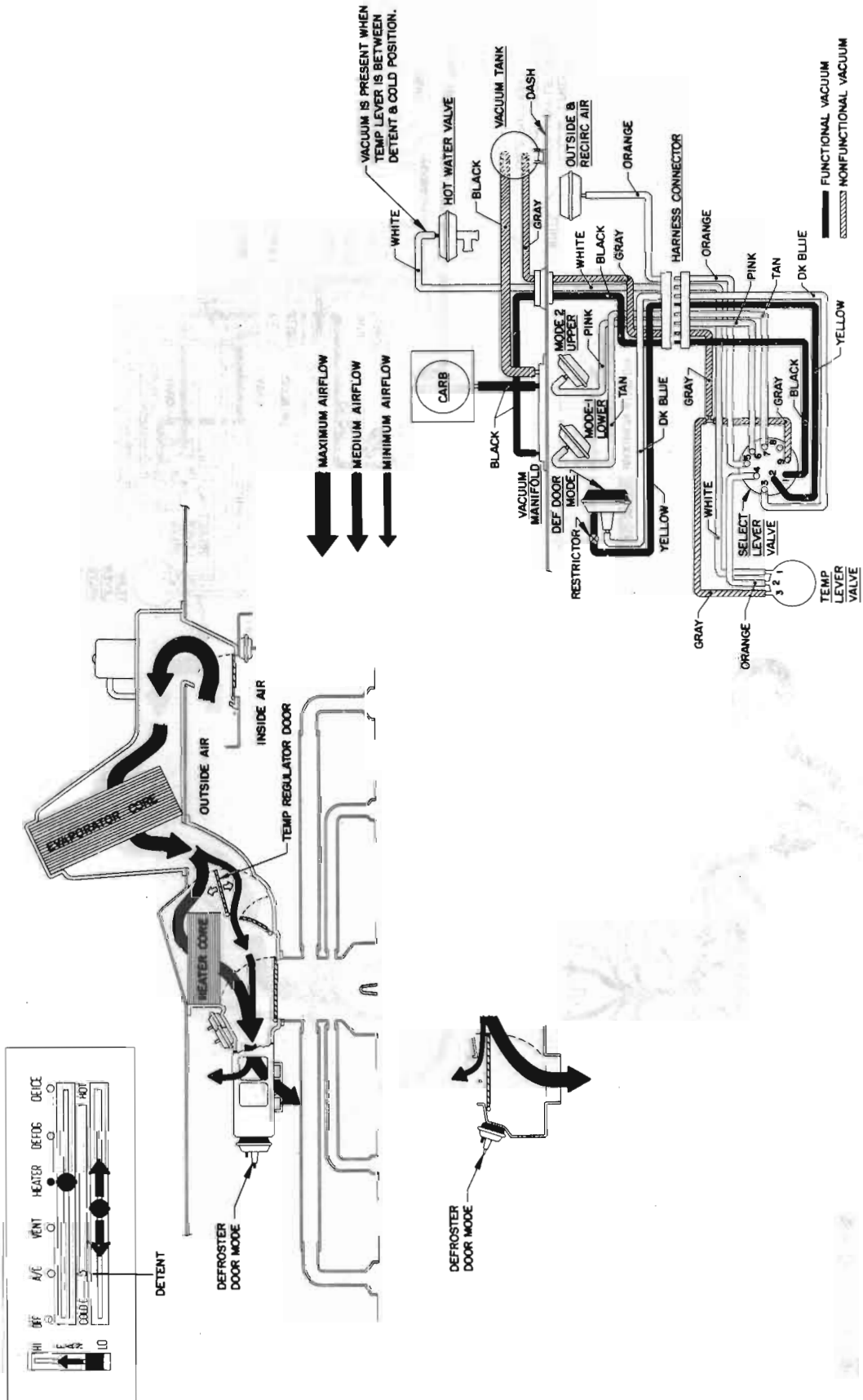

13-359A

Figure 13-103 45-46-48-49000 Series Control Position, Vacuum Circuits, and Air Flow During HTR Mode

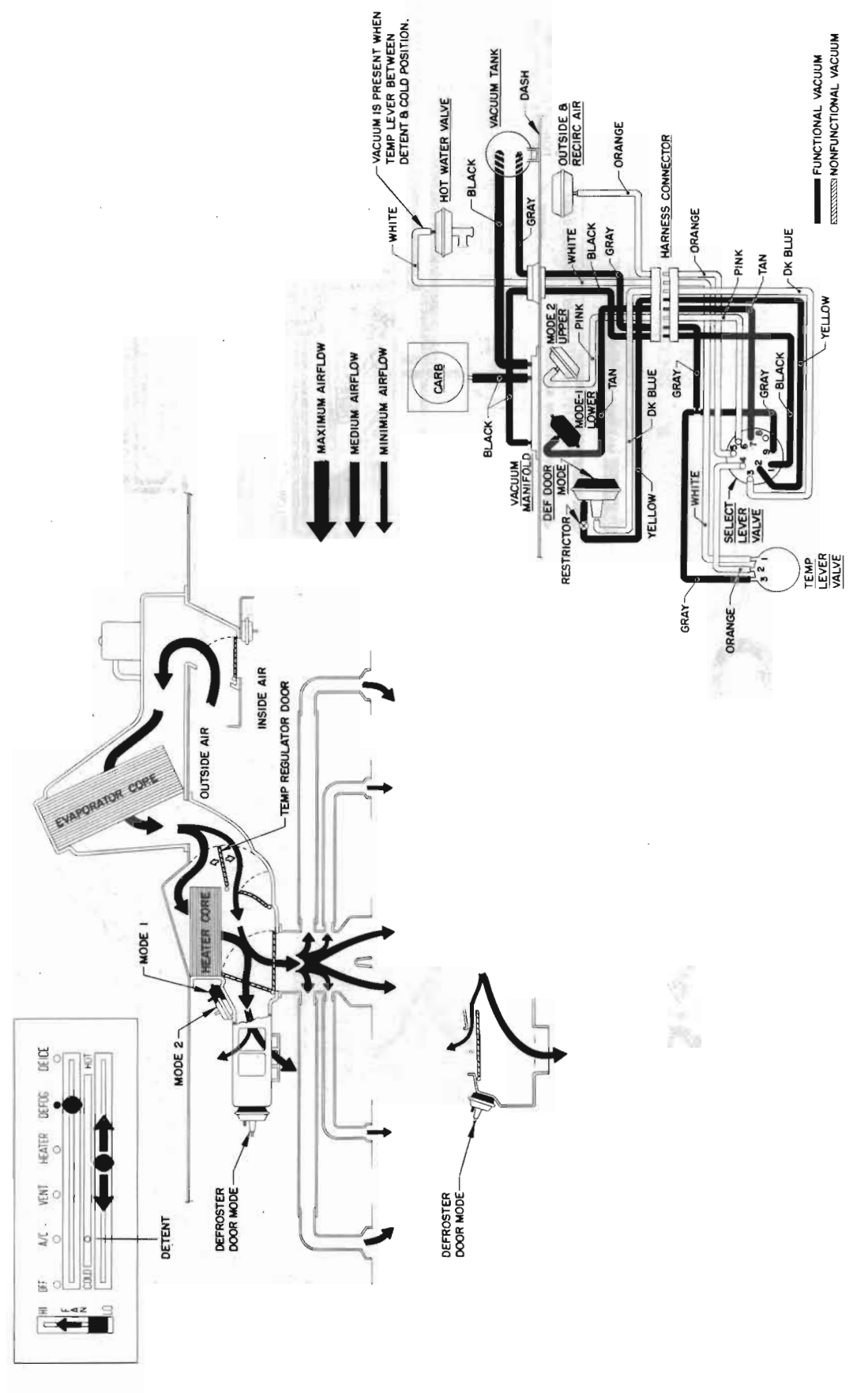

13-360A

Figure 13-104 45-46-48-49000 Series Control Position, Vacuum Circuits, and Air Flow During DEFROG Mode

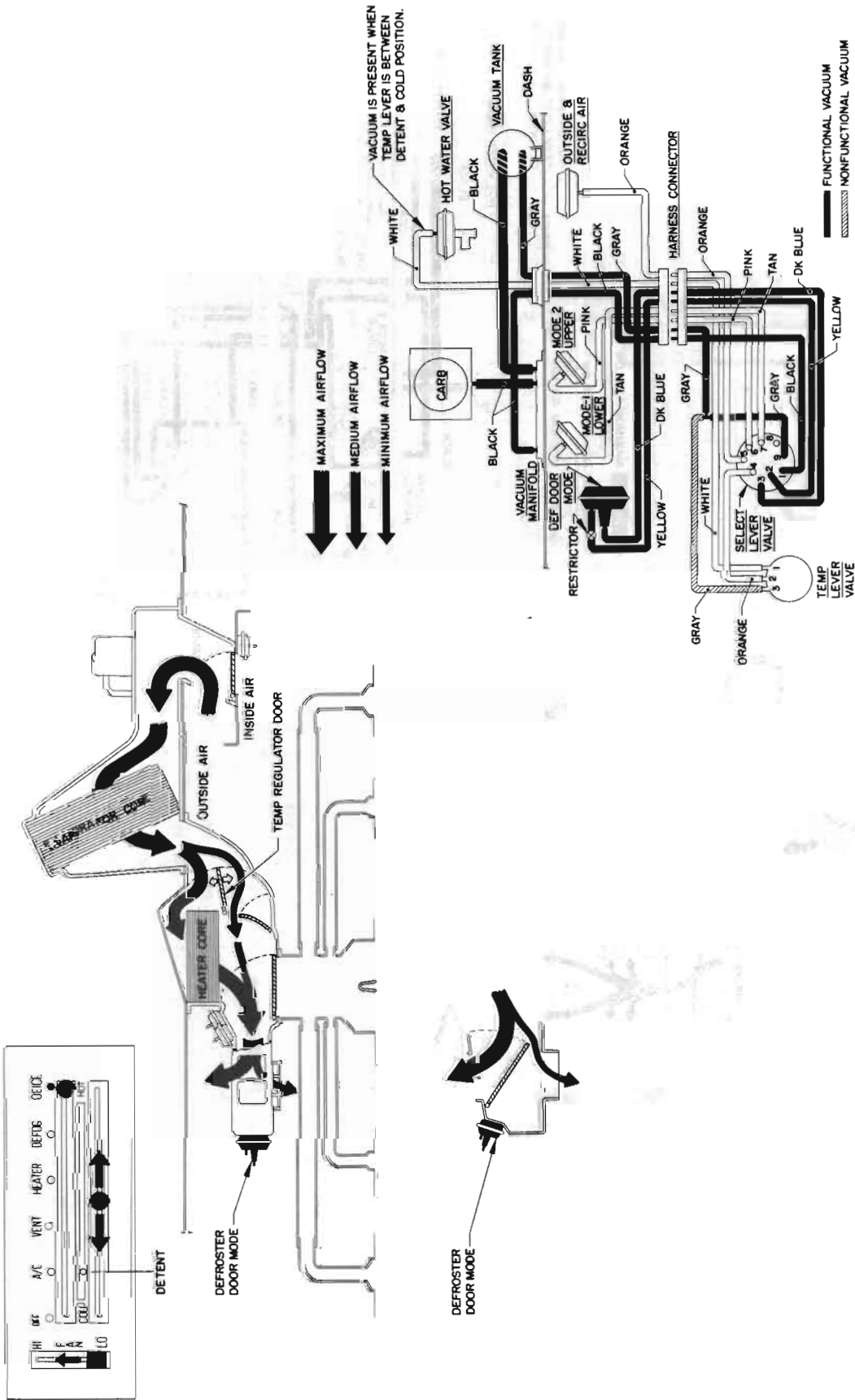

13-361A

Figure 13-105 45-46-48-49000 Series Control Position, Vacuum Circuits, and Air Flow During DEICE Mode

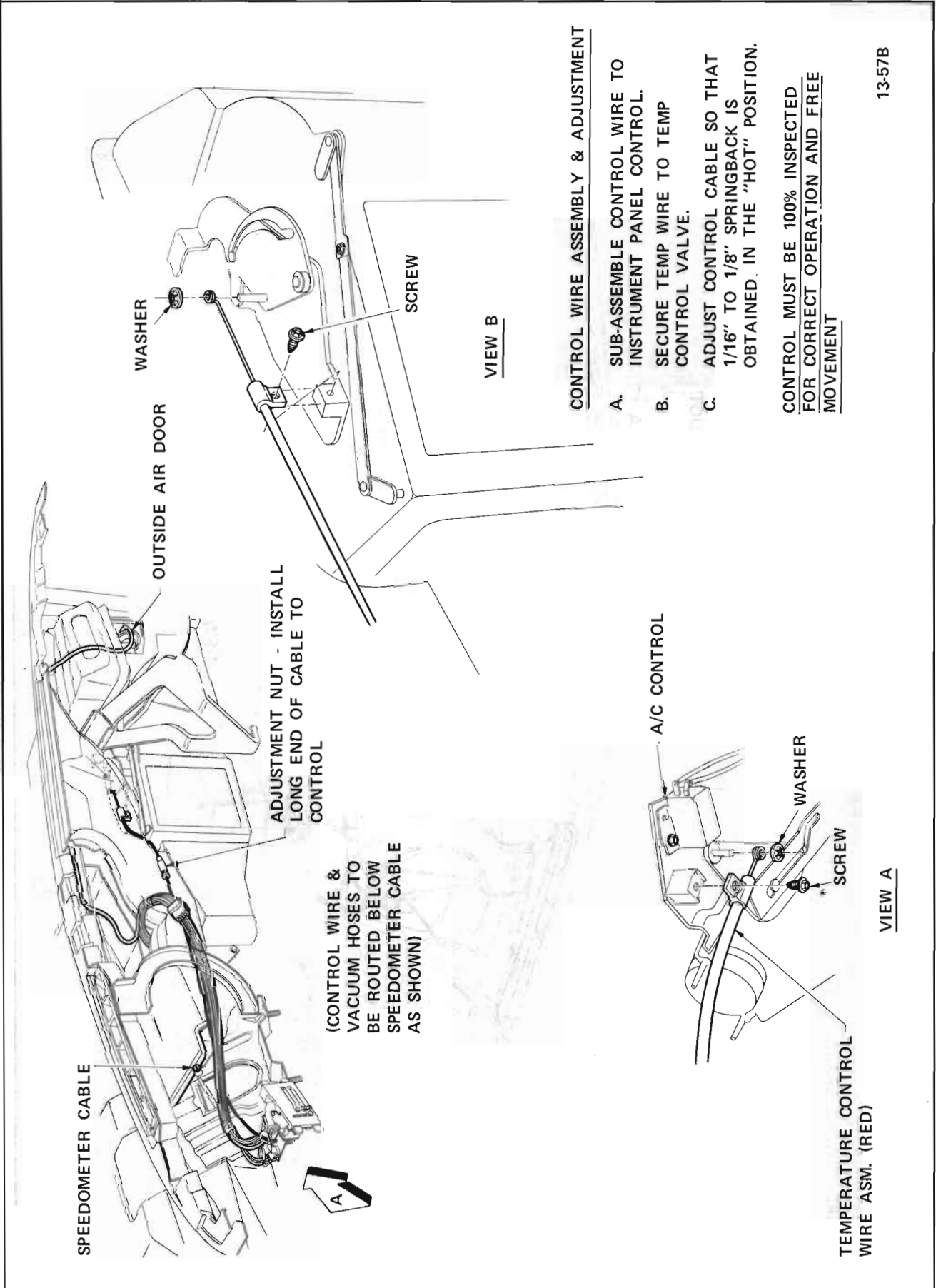
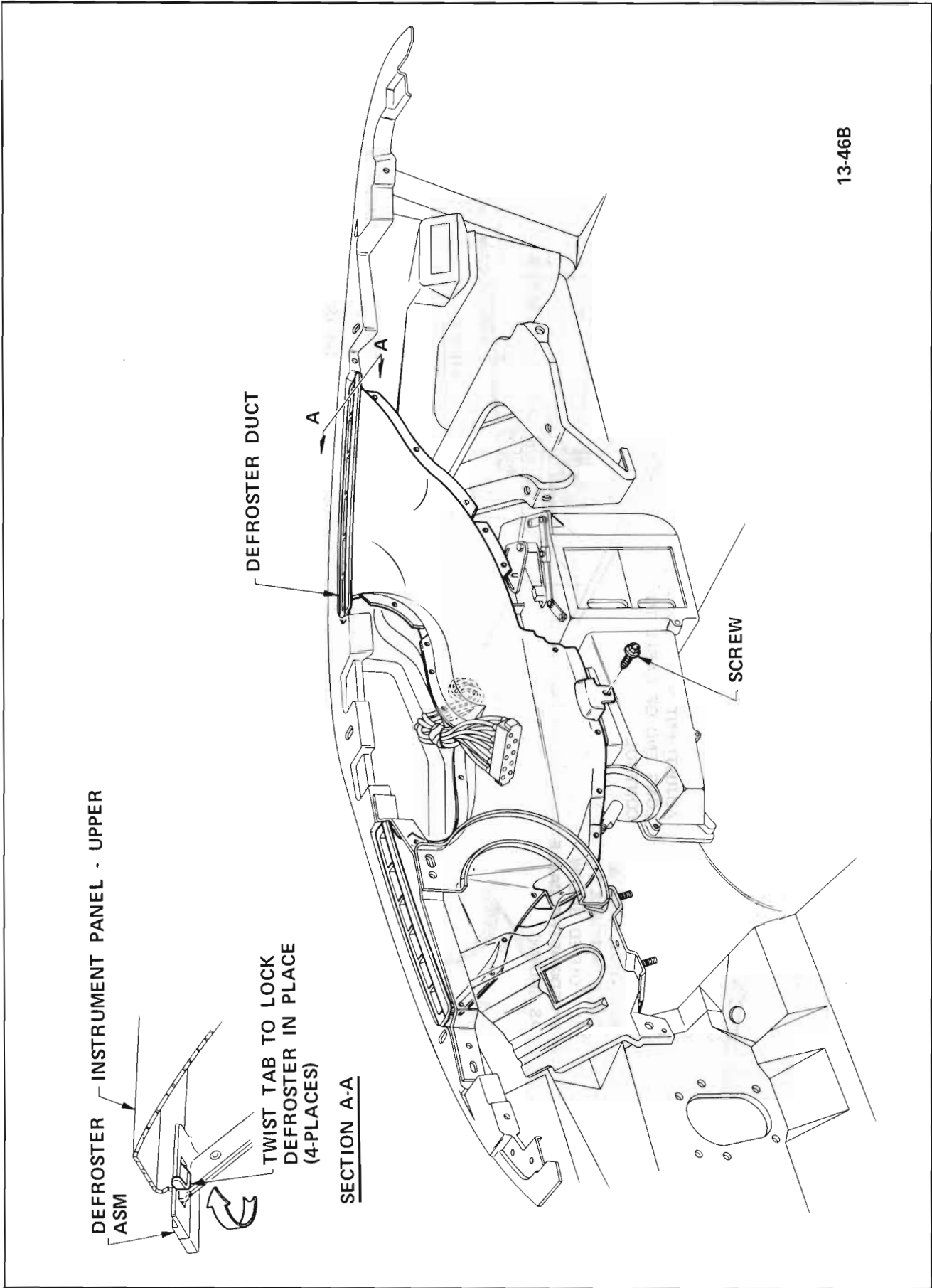

Figure 13-106 45-46-48-49000 Series Heater - A/C Control Wire



13-46B

Figure 13-107 45-46-48-49000 Series Defroster Duct to Heater

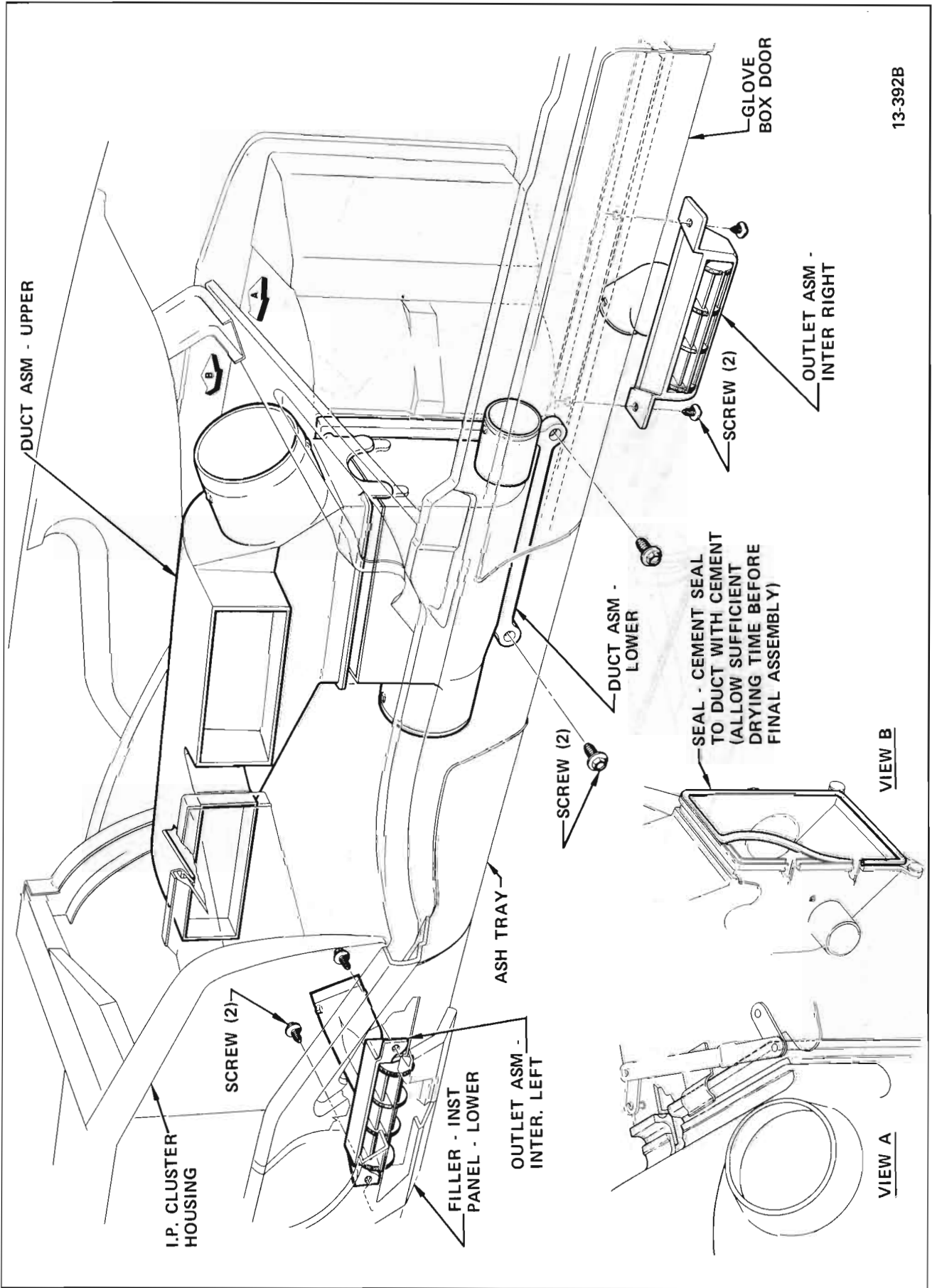
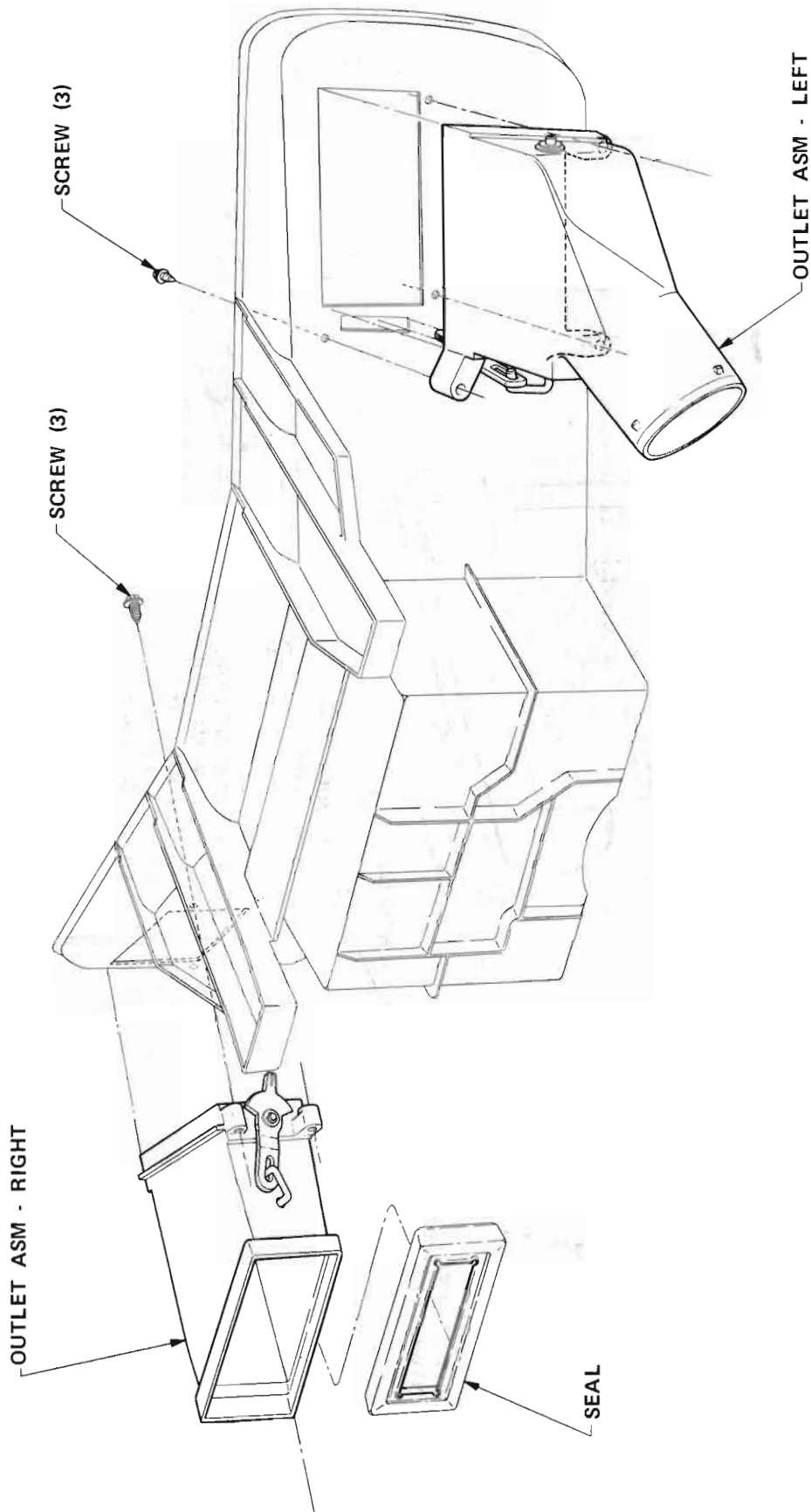

Figure 13-108 45-46-48-49000 Series Intermediate and Center Outlet





13-390B

Figure 13-109 45-46-48-49000 Series Outlets to Instrument Panel Cluster Housing

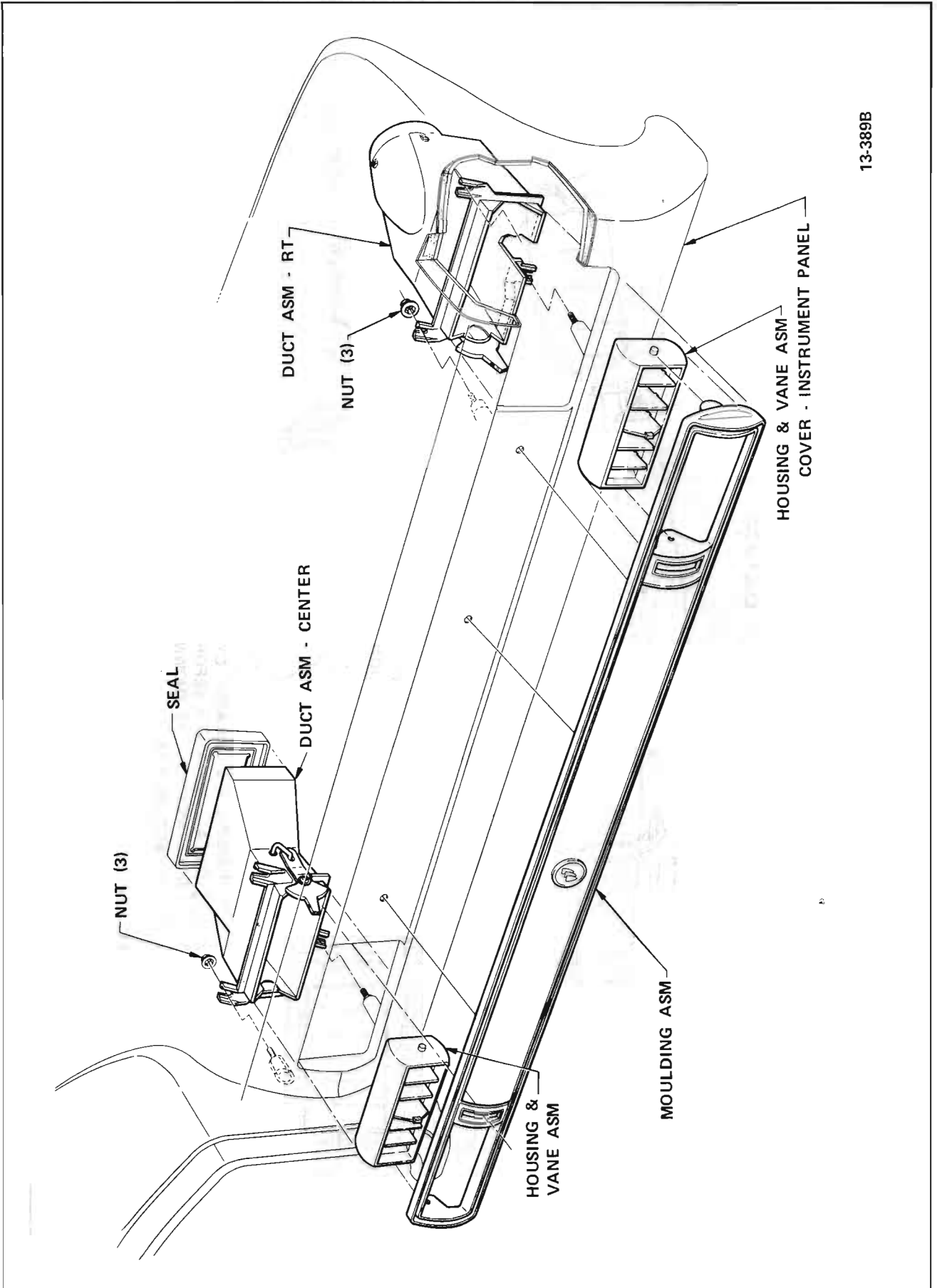

13-389B

Figure 13-110 45-46-48000 Series Outlets to Instrument Panel Cover

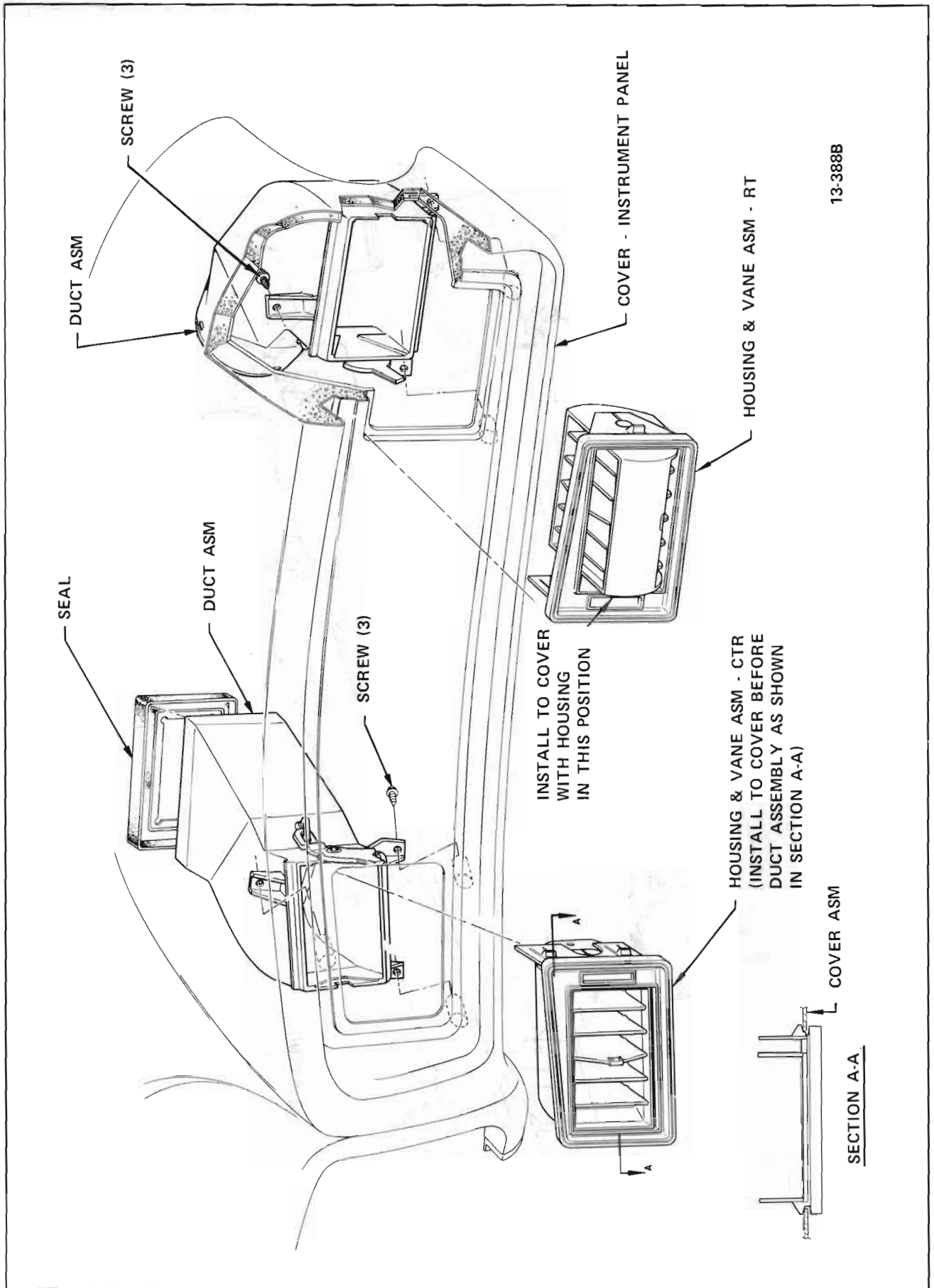
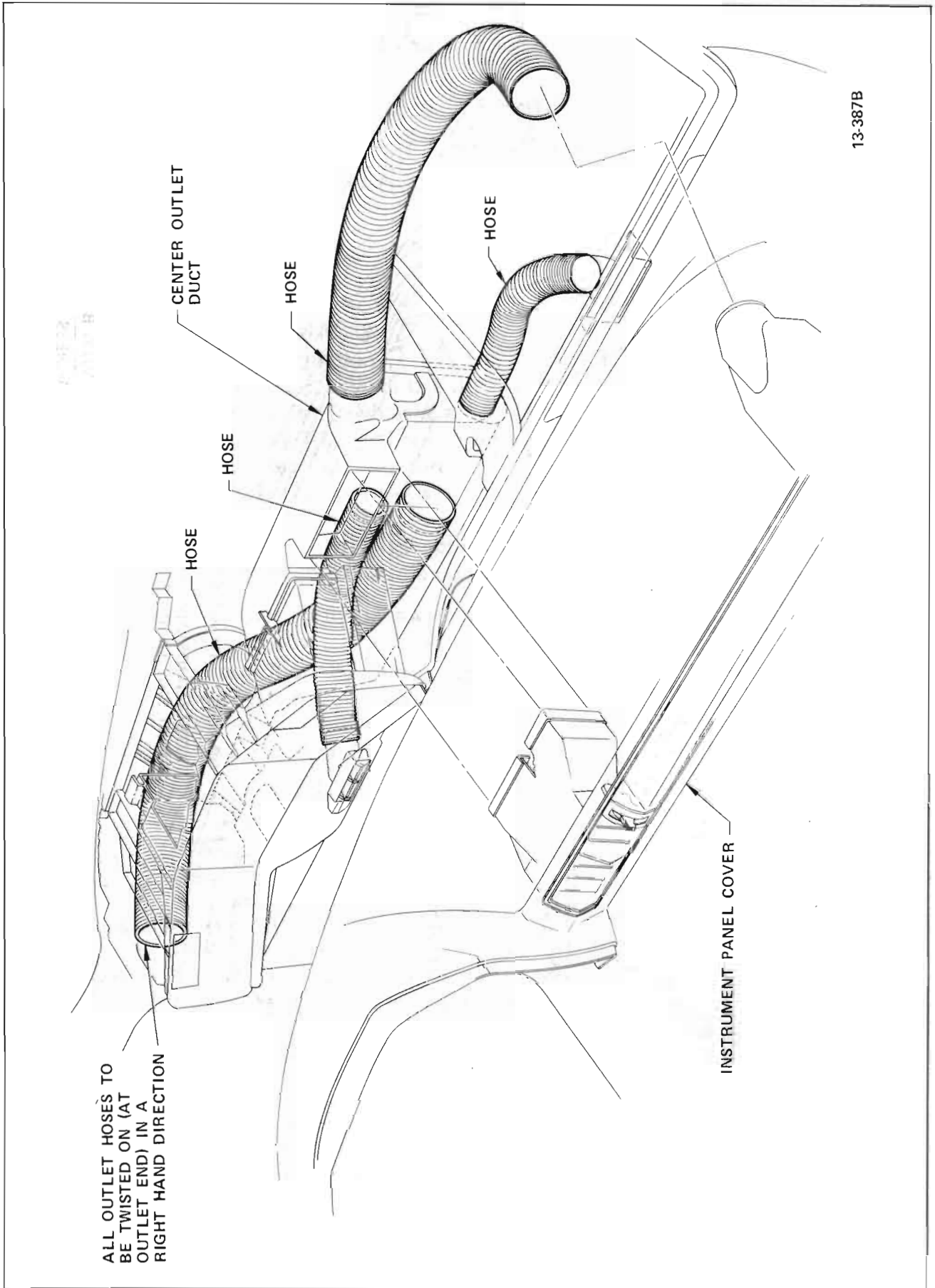
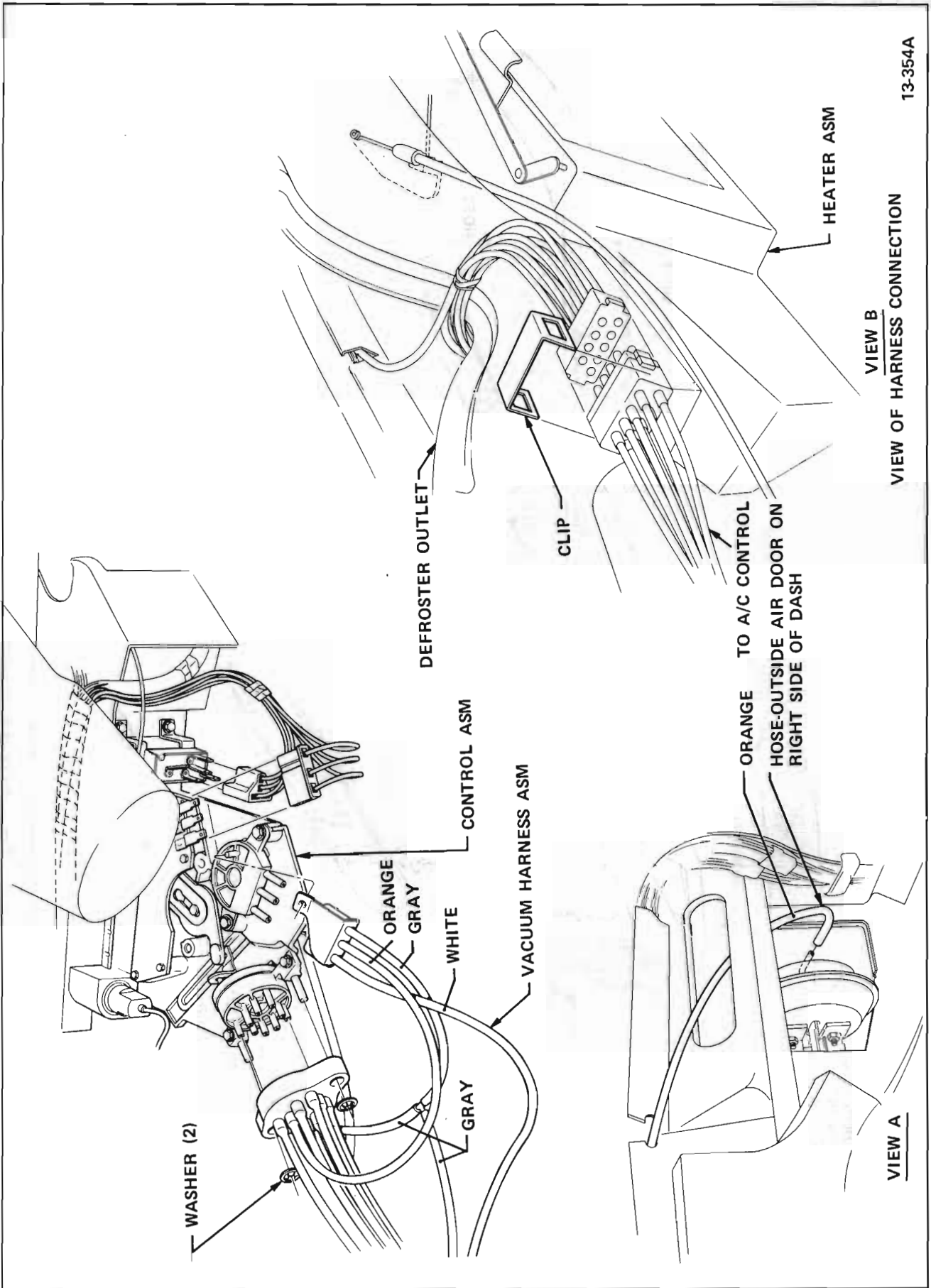

Figure 13-111 49000 Series Outlets to Instrument Cover



13-387B

Figure 13-112 45-46-48-49000 Series Outlet Hose Routing



VIEW B  
VIEW OF HARNESS CONNECTION

VIEW A

13-354A

Figure 13-113 45-46-48-49000 Series Vacuum Hose Connections