

SECTION A

THREE-SPEED MANUAL TRANSMISSION SKYLARK (COLUMN SHIFT), SKYLARK 350 AND SPORTWAGON MODELS

CONTENTS

Division	Subject	Paragraph
I	SPECIFICATIONS AND ADJUSTMENTS: General Specifications	72-1
II	DESCRIPTION AND OPERATION: Description of the 3-Speed Manual Transmission	72-2
III	SERVICE PROCEDURES: Removal and Installation of Transmission	72-3
	Disassembly of Transmission	72-4
	Mainshaft Assembly	72-5
	Rear Bearing Retainer Seal and Bushing	72-6
	Countergear Assembly	72-7
	Side Cover Assembly	72-8
	Cleaning and Inspection of Transmission Parts	72-9
	Front Main Bearing Retainer Oil Seal	72-10
	Transmission Reassembly	72-11
IV	TROUBLE DIAGNOSIS: Trouble Diagnosis	72-12

DIVISION I SPECIFICATIONS AND ADJUSTMENTS

72-1 GENERAL SPECIFICATIONS

a. Transmission Identification

A production code number and Car Serial Number are stamped on all Skylark, Skylark 350, Sportwagon, G.S., G.S. 455, LeSabre and Wildcat three-speed manual transmissions. See Figure 72-1 for location of these numbers.

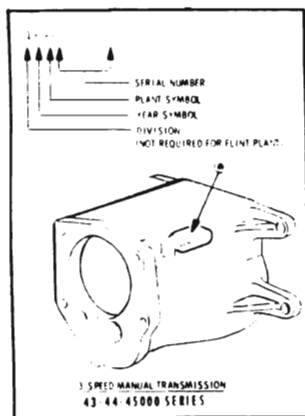

CAR SERIAL NUMBER
LOCATION

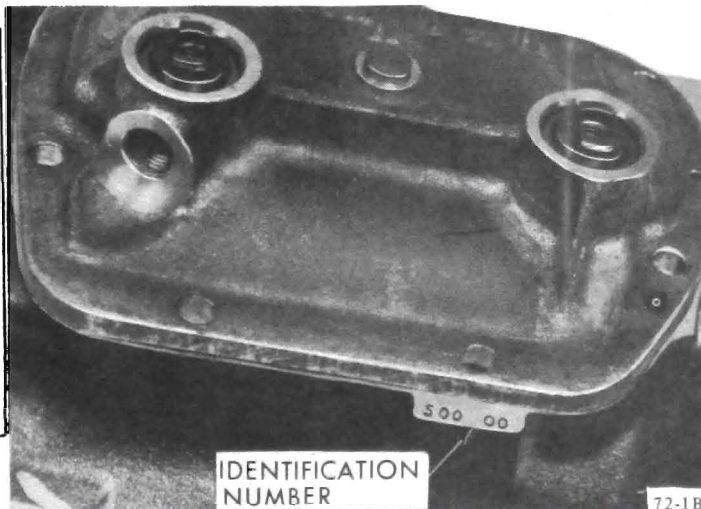

Figure 72-1-Transmission Identification Number Locations

These numbers should always be furnished on all product reports, AFA forms, and all correspondence with the factory concerning a particular transmission.

DIVISION II

DESCRIPTION AND OPERATION

72-2 DESCRIPTION OF THE 3- SPEED MANUAL TRANSMISSION

The Skylark, Skylark 350, Sportwagon and G.S. Series cars have as

standard equipment a three-speed manually operated transmission with all forward gears synchronized. All forward speed changes are accomplished with synchronizer sleeves. See Figure 72-2. The synchronizers permit quicker shifts, greatly reduce gear clash, and permit down shifting from third to second between 40-20 MPH AND FROM SECOND TO FIRST BELOW 20 mph. Power flow in all gears is shown in Figure 72-3.

DIVISION III

SERVICE PROCEDURES

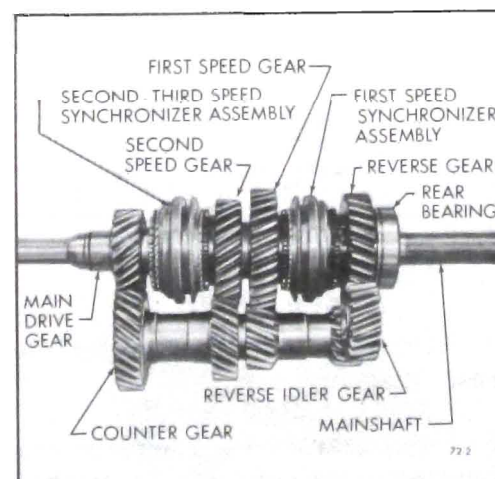

Figure 72-2-Gear
Synchronizers

72-3 REMOVAL AND INSTALLATION OF TRANSMISSION

a. Removal

1. Disconnect speedometer cable and remove driven gear and sleeve assembly.
2. Disconnect shift controls from transmission.
3. Remove propeller shaft.
4. Support rear of engine and remove transmission support.
5. Remove the two (2) top transmission to flywheel housing bolts and insert guide pins.
6. Remove the two (2) lower transmission to flywheel housing attaching bolts.
7. Slide transmission straight back on guide pins until the main drive gear is free of splines in the clutch driven plate.

NOTE: If guide pins are not used, damage to the clutch driven plate can result.

8. Remove transmission.

b. INSTALLATION

1. Install guide pin in upper and lower right transmission to flywheel housing bolt holes for alignment and place transmission on guide pins. Place transmission in third gear and rotate transmission mainshaft as necessary to start main drive gear into clutch driven plate. Slide transmission forward.

NOTE: If guide pins are not used, damage to the clutch driven plate can result.

2. Install two (2) lower transmission mounting bolts. Remove guide pin and install two upper bolts. Torque bolts to 45-60 lb. ft.
3. Install transmission support.
4. Install propeller shaft.
5. Install speedometer driven gear and connector speedometer cable.

72-4 THREE-SPEED MANUAL TRANSMISSION

b. General Specifications

Type	All Forward Gears Synchronized	
Mounting	Unit with Engine	
Lubricant		
Type	SAE 80 or 90 Multi-Purpose	
Capacity	3½ Pints	
Synchronization	1st, 2nd and 3rd	
Gear Ratios	L-6	V-8
1st	2.84 to 1	2.54 to 1
2nd	1.68 to 1	1.50 to 1
3rd	1.00 to 1	1.00 to 1
Reverse	2.94 to 1	2.63 to 1
Gear Shifting	On Steering Column	
Speedometer Drive Gear	Nylon	

c. Bolt Tightening Specifications

Location	Thread Size	Torque Lbs. Ft.
Front Main Bearing Retainer	5/16 - 18 x ¾	8 - 12 lb. ft.
Side Cover to Case	5/16 - 18 x ¾	8 - 12 lb. ft.
Rear Main Bearing Retainer	7/16 - 14 x 1½	35 - 55 lb. ft.
Shift Lever to Shifter Shaft Bolts	¾ - 16 x 1	20 - 30 lb. ft.
Lubrication Filler Plug	½ - 14	10 - 15 lb. ft.
Transmission Case to Flywheel Housing	7/16 - 14 x 1¼	45 - 60 lb. ft.

Use a reliable wrench to tighten the parts listed to insure proper tightness without straining or distorting parts. These specifications are for **clean and lightly lubricated threads only**; dry or dirty threads produce increased friction which prevents accurate measurement of tightness.

6. Connect linkage and adjust as described in Group 73.

72-4 DISASSEMBLY OF TRANSMISSION

1. Drain lubricant.
2. Remove side cover attaching bolts. Remove side cover assembly and gasket.
3. Remove front main bearing retainer and gasket.
4. Remove front main bearing to main drive gear snap ring.
5. Remove front main bearing by pulling main drive gear out of case as far as possible. See Figure 72-4. Remove front bearing.

NOTE: *Front bearing is a slip fit on main drive gear. It may be necessary to aid removal with a screwdriver.*

6. Remove reverse idler shaft to gear "E" ring. See Figure 72-5.

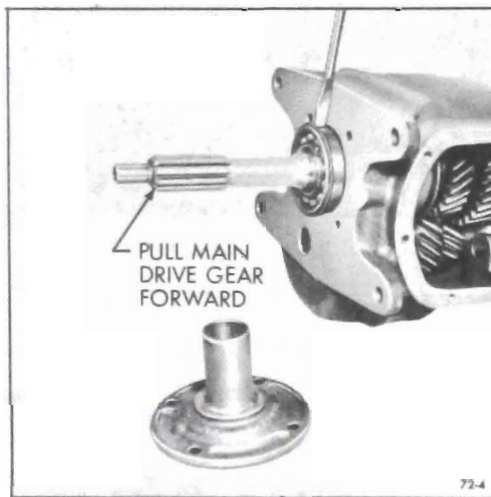

Figure 72-4-Removing Front Main Bearing

7. Remove rear bearing retainer to case attaching bolts.
8. From rear of case, remove rear bearing retainer and mainshaft assembly. See Figure 72-6.
9. Remove main drive gear, 14 needle bearings, and third speed blocking ring from mainshaft assembly.

10. Using snap ring pliers, expand snap ring at rear of bearing retainer which retains the rear bearing to the retainer. See Figure 72-7. Remove rear bearing retainer.

11. Using Countershaft Alignment Tool J-22246, remove counter gear shaft and its woodruff key through rear of case. See Figure 72-8. Remove two (2) tanged bronze thrust washers.

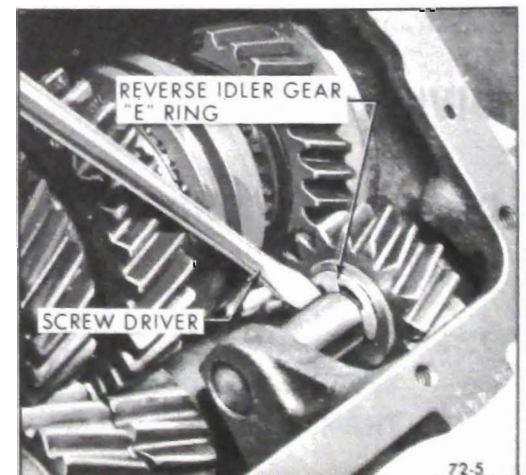

Figure 72-5-Removing Reverse Idler 'E' Ring

72A-3

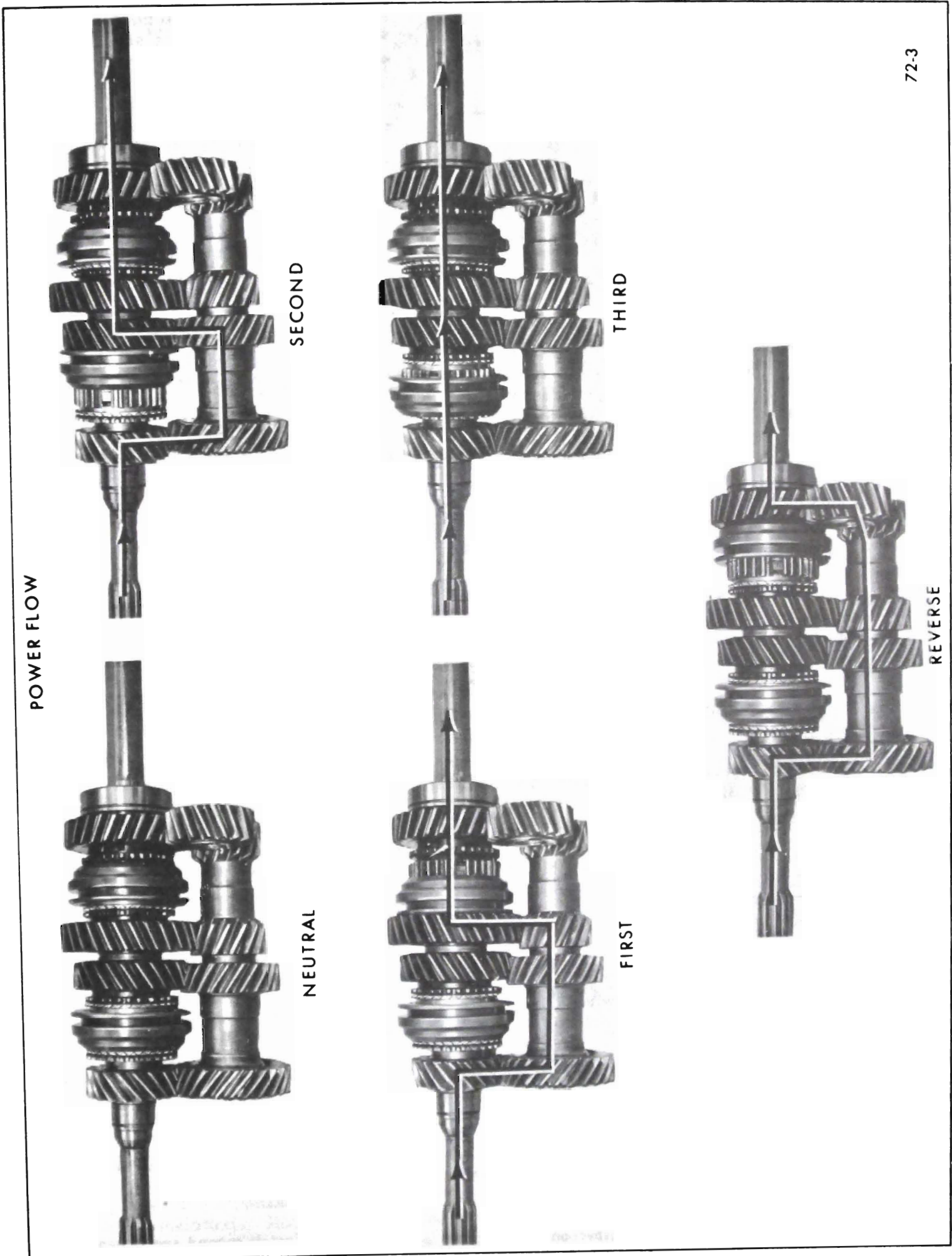

Figure 72-3 Power Flow

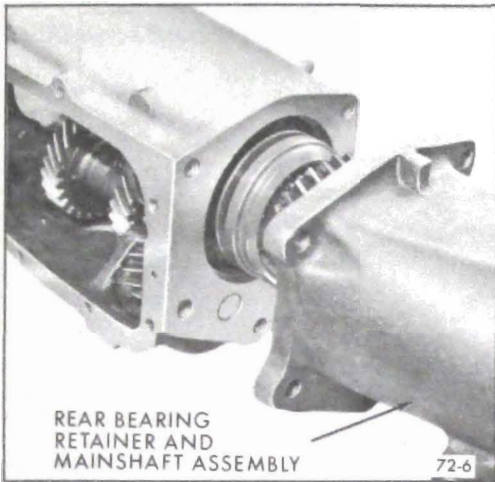

Figure 72-6-Removing Mainshaft Assembly

12. Use a long brass drift and drive reverse idler shaft and woodruff key through rear of case. See Figure 72-9.

13. Remove reverse idler gear tanged steel thrust washer.

72-5 MAINSHAFT ASSEMBLY

a. Disassembly

1. Remove second-third synchronizer sleeve. See Figure 72-10.

2. Remove rear bearing snap ring. See Figure 72-11.

3. Using ram press or arbor press, remove rear bearing spring washer, thrust washer, and reverse gear. See Figure 72-12.

4. Remove speedometer drive gear. See Figure 72-13. Depress retainer clip, then slide speedometer gear off output shaft.

5. Remove first speed synchronizer snap ring. See Figure 72-14.

6. Support first speed gear on press plate using two (2) pieces of stock 6x1-7/8x1/4. See Figure 72-15. Remove first speed synchronizer assembly and first speed gear.

7. Remove second-third speed synchronizer assembly snap ring. See Figure 72-16.

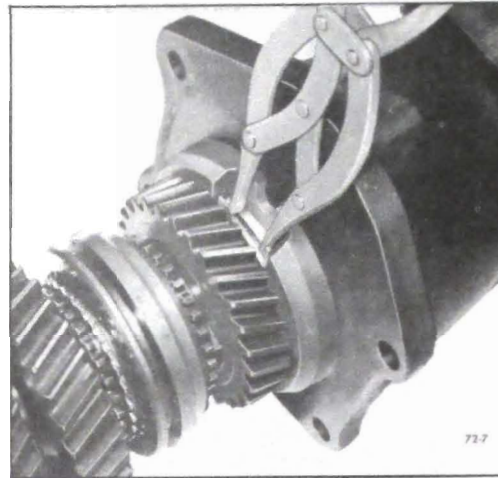

Figure 72-7-Removing Rear Bearing Retainer.

8. Support second speed gear on press plate using two (2) pieces of stock 6x1-7/8x1/4. See Figure 72-17.

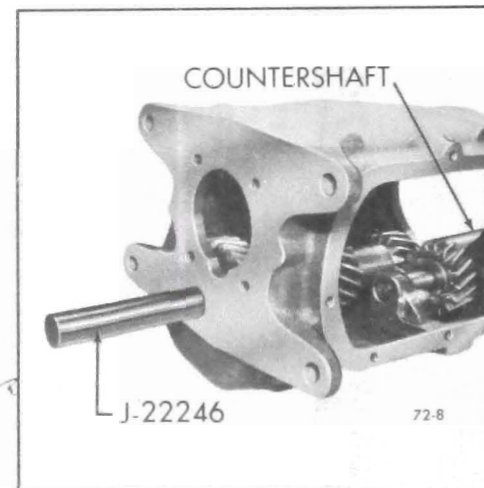

Figure 72-8-Removing Countershaft

Remove second-third speed synchronizer assembly and second speed gear.

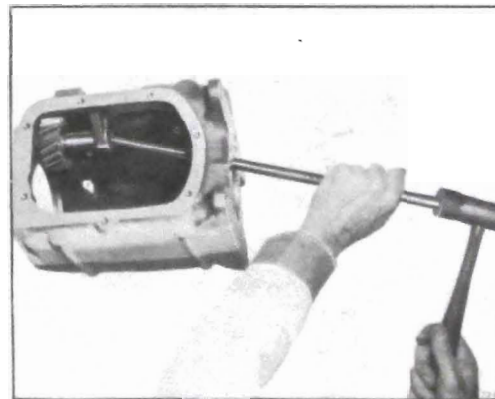

Figure 72-9 - Removing Reverse Idler Shaft

b. Inspection

1. Check synchronizer hubs, sliding keys and springs and, if necessary, replace as follows:

NOTE: The synchronizer hubs and sliding sleeves are a selected assembly and should be kept together as originally assembled. The keys and springs must be replaced if worn or broken.

a. Mark hub and sleeve with paint so they can be reassembled in the same position.

b. Remove sliding sleeve from synchronizer hub. Remove keys and springs from the hub. See Figure 72-18.

c. Place the three (3) keys and two springs in position (one on each side of hub) so all three (3) keys are engaged by both springs. See Figure 72-18.

The tanged end of each synchronizer spring should be installed in different key cavities on either side of hub. Slide the sleeve onto the hub aligning the marks made before disassembly.

NOTE: An identification ring around the outside of the synchronizer hub splines identifies the end that must be opposite fork slot in sleeve. See Figure 72-19.

2. Wash front and rear bearing thoroughly in a cleaning solvent. Blow out bearing with compressed air.

CAUTION: Do not allow the bearings to spin; turn them slowly by hand. Spinning bearings will damage the race and balls.

Make certain bearings are clean, then lubricate with light engine oil and check them for roughness by slowly turning the race by hand.

3. Check for cracks in blocking rings.

c. Assembly

1. Install second speed gear blocking

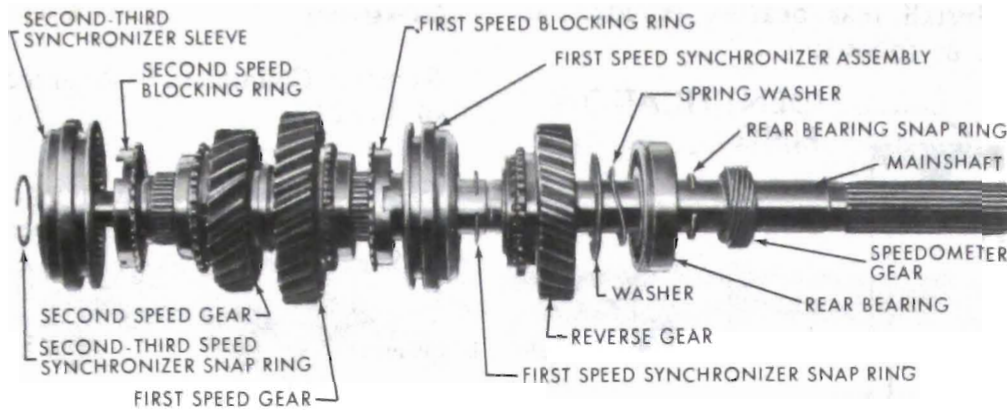

Figure 72-10 - Exploded View of Mainshaft

ring on mainshaft. Using ram press or arbor press and Press Plate J-8609, press second-third speed synchronizer assembly (with identification ring toward front of transmission) onto mainshaft. See Figure 72-20. Install retaining snap ring.

retaining snap ring.

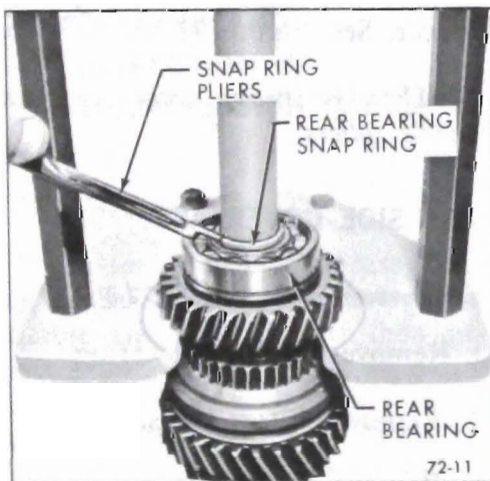

Figure 72-11 - Removing Rear Bearing Snap Ring

CAUTION: Make certain notches in blocking ring align with keys in synchronizer assembly.

2. Install first speed gear and synchronizer on mainshaft. See Figure 72-21. Using ram press and Press Plate J-8609, press first speed synchronizer assembly (with identification ring toward rear of transmission) onto mainshaft. Install

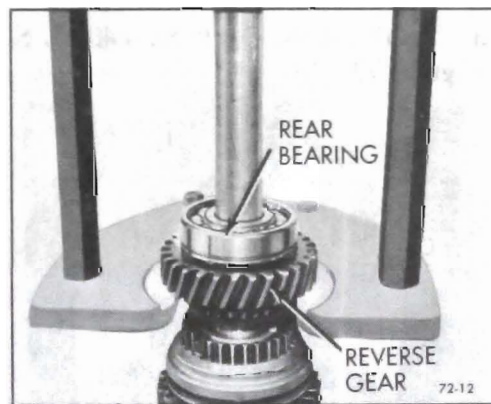

Figure 72-12 - Removing Rear Bearing

CAUTION: Make certain notches in blocking ring align with keys in first speed synchronizer assembly.

3. Install reverse gear, thrust washer, spring washer, and rear bearing. See Figure 72-22.

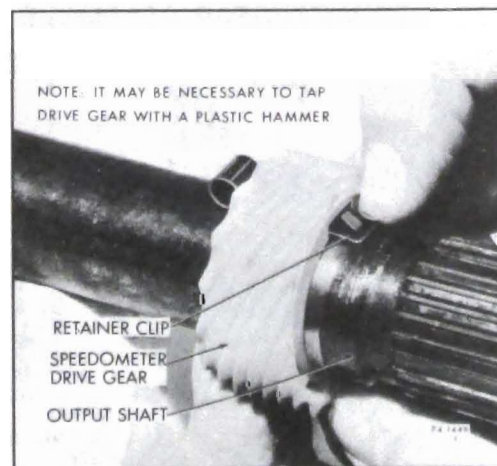

Figure 72-13 - Removing Speedometer Drive Gear

NOTE: Groove on bearing must be toward reverse gear. Using ram press or arbor press, press rear bearing into position. See Figure 72-23. Install retaining snap ring.

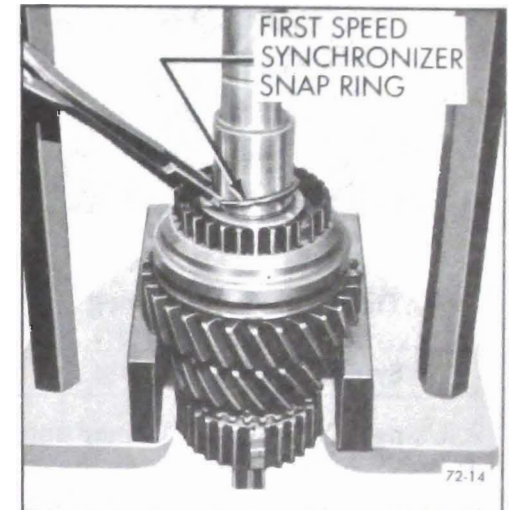

Figure 72-14 - Removing First Speed Synchronizer Snap Ring

4. Install speedometer drive gear retainer clip. Align slot in speedometer drive gear with retainer clip and install. See Figure 72-24.

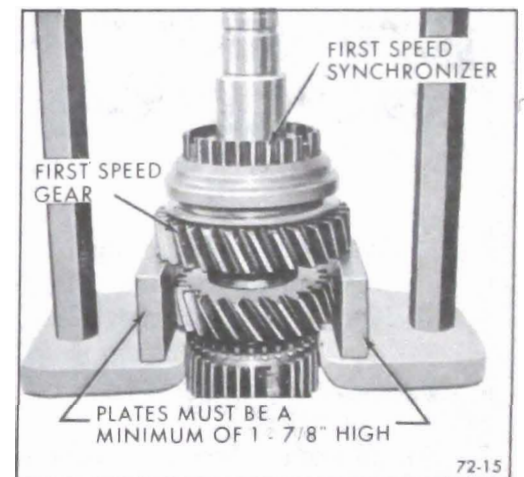

Figure 72-15 - Removing First Speed Synchronizer Assembly

5. Install second-third synchronizer sleeve. See Figure 72-22.

72-6 REAR BEARING RETAINER SEAL AND BUSHING

a. Removal

1. Using J-2619 Slide Hammer and J-4830-02 Puller, remove rear bearing retainer oil seal. See Figure 72-25.

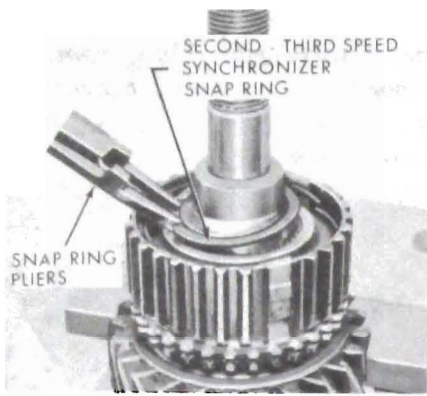

Figure 72-16 - Removing Second-Third Speed Synchronizer Snap Ring

2. Using J-2619 Slide Hammer and J-4830-02 Puller, remove rear bearing retainer bushing. See Figure 72-26.

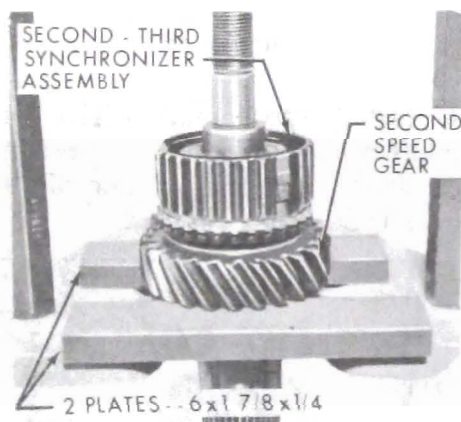

Figure 72-17 - Removing Second-Third Speed Synchronizer Assembly

b. Installation

1. Install rear bearing retainer bushing, using Tool J-6403-1. See Figure 72-27.

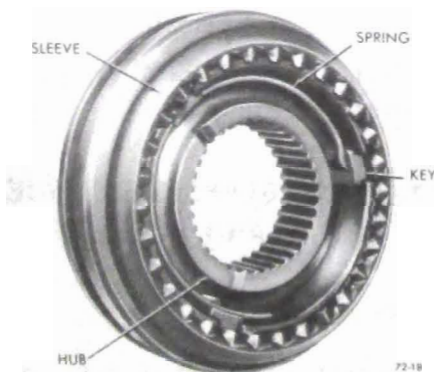
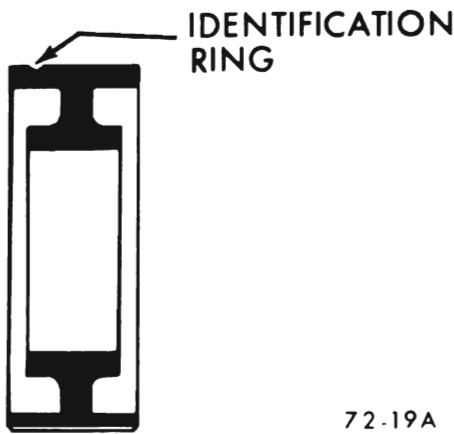

Figure 72-18 - Synchronizer Assembly

2. Install rear bearing retainer oil seal as follows:



72-19A

Figure 72-19 - Identification Ring

a. Install J-6403-2 onto J-6403-1. See Figure 72-28.

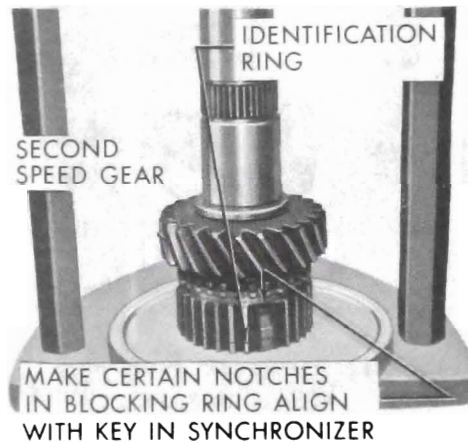

Figure 72-20 - Installing Second Speed Gear

NOTE: Flat side of J-6403-2 must be toward rear of J-6403-1.

b. Install oil seal.

72-7 COUNTERGEAR ASSEMBLY

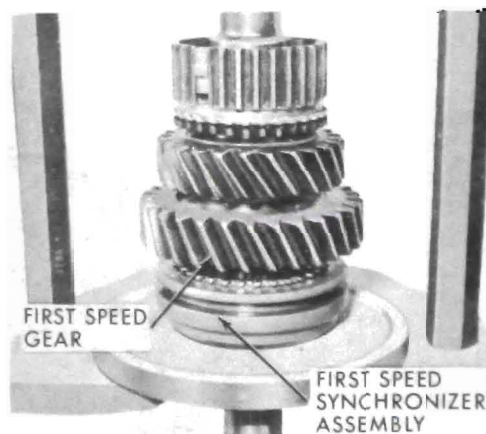

Figure 72-21 - Installing First Speed Gear

a. Disassembly

1. Remove Countershaft Alignment Tool J-22246.

2. From each end of countershaft, remove spacer and 27 needle bearings. See Figure 72-29.

b. Inspection

1. Check for broken needle bearings.
2. Check for broken anti-rattle gear springs. See Figure 72-30.

NOTE: The anti-rattle gear is riveted to the countergear and is not serviced separately.

C. Assembly

1. Install Countershaft Alignment Tool J-22246.

2. From each end of countergear, install 27 needle bearings and spacer. See Figure 72-29.

NOTE: Use heavy grease to retain needle rollers.

72-8 SIDE COVER ASSEMBLY

a. Disassembly (See Figure 72-31)

1. Remove detent cam spring.
2. Remove shifter forks.
3. Remove shifter shafts.
4. Remove detent cam retainer.
5. Remove detent cams.
6. Inspect shifter shaft "O" rings and replace, if necessary.

b. Assembly (See Figure 72-31)

1. Install shifter shaft "O" rings, if removed.
2. Install detent cams.
3. Install detent cam retainer.
4. Install shifter shafts.

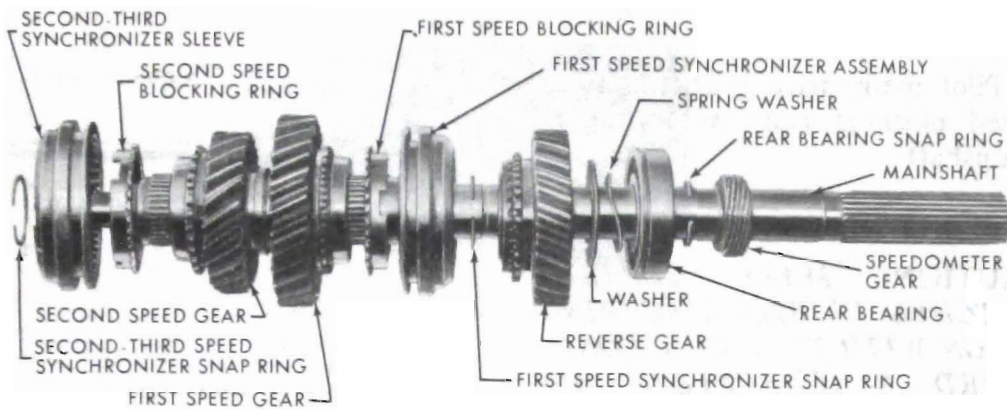

Figure 72-22 - Exploded View of Mainshaft

5. Install shifter forks.

6. Install detent cam spring.

NOTE: *Detent cams, shifter shafts and forks are interchangeable.*

72-9 CLEANING AND INSPECTION OF TRANSMISSION PARTS

a. Transmission Case

1. Wash the transmission case thoroughly inside and outside with a suitable cleaning solvent; then inspect case for cracks.

2. Check front and rear faces for burrs, and if present, remove with a fine mill file.

3. Check and clean magnet in bottom of transmission case.

b. Needle Bearings

All main drive gear and countergear needle bearings should be inspected closely and replaced if they show wear.

c. Transmission Gears

1. Inspect all gears for excessive wear, chips or cracks.



Figure 72-23 - Installing Rear Bearing

2. Inspect reverse gear bushing and if worn or damaged, replace the entire gear.

NOTE: *Reverse gear bushing is not serviced separately.*

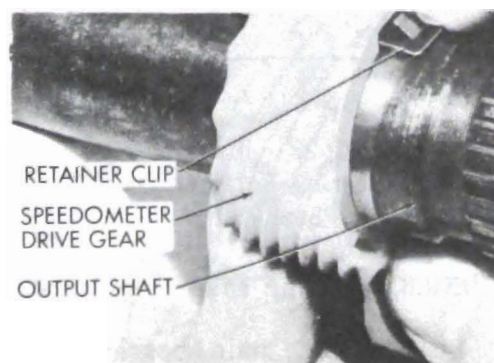

Figure 72-24 - Installing Speedometer Drive Gear

3. Inspect reverse idler gear bushing and if worn or damaged, replace the entire gear.

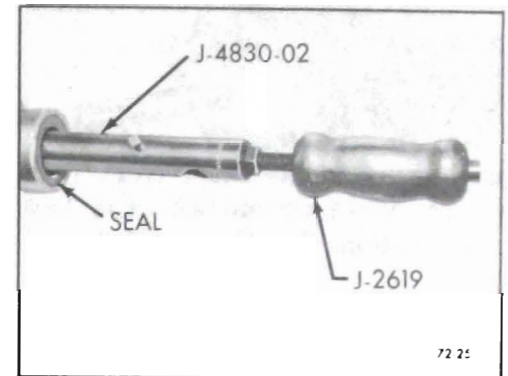

Figure 72-25 - Removing Rear Bearing Retainer Oil Seal

72-10 FRONT MAIN BEARING RETAINER OIL SEAL

a. Removal

1. Using screwdriver remove seal. See Figure 72-32.

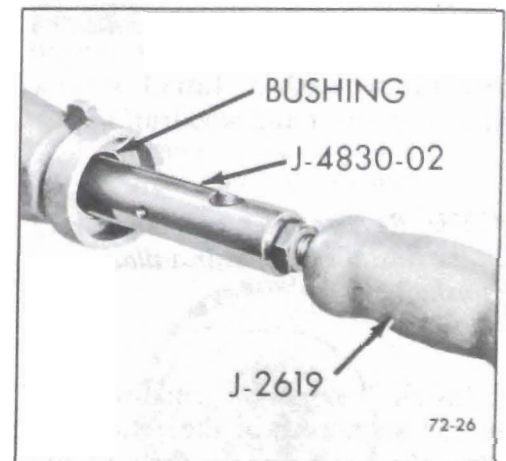

Figure 72-26 - Removing Rear Bearing Retainer Bushing

b. Installation

1. Using a suitable tool, drive new seal into position. See Figure 72-33.

NOTE: *Lip of seal must face rear of bearing retainer.*

72-10 THREE-SPEED MANUAL TRANSMISSION

72-II TRANSMISSION
REASSEMBLY

1. Install countergear to case bronze thrust washers.

2. Install countergear into case. Install countergear shaft from rear of case. Make certain woodruff key is in position. See Figure 72-34.

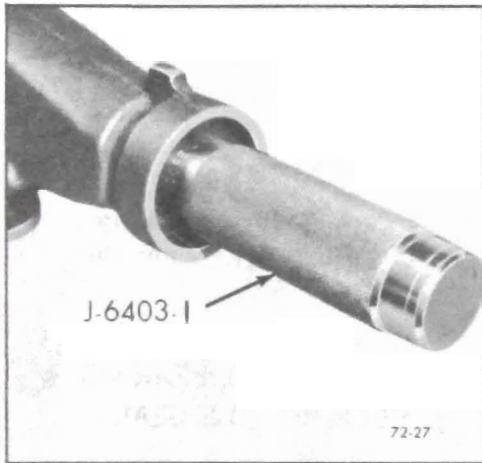

Figure 72-27 - Installing
Rear Bearing Retainer
Bushing

3. Install reverse idler gear tanged steel thrust washer. Install reverse idler gear, shaft and woodruff key.

NOTE: Reverse idler gear snap ring will be installed after installation of mainshaft.

4. Install the rear bearing retainer. Spread snap ring in the retainer to allow the snap ring to drop around rear bearing. See Figure 72-35. Press on end of mainshaft until the snap ring engages groove in rear bearing.

5. Install fourteen (14) needle bearings in main drive gear, using heavy grease to hold the bearings in place. See Figure 72-36.

6. Assemble third speed blocking ring on main drive gear.

7. Pilot main drive gear and third speed blocking ring over front of mainshaft.

CAUTION: MAKE CERTAIN NOTCHES IN BLOCKING RING ALIGN WITH KEYS IN SECOND-THIRD SYNCHRONIZER ASSEMBLY.

8. Using heavy grease, install rear bearing retainer to case gasket.

9. Install rear bearing retainer and mainshaft assembly into case. Install bearing retainer to case bolts. Torque 35-55 lb.ft.

10. Install front main bearing onto main drive gear. Outer snap ring groove must be toward front of gear.

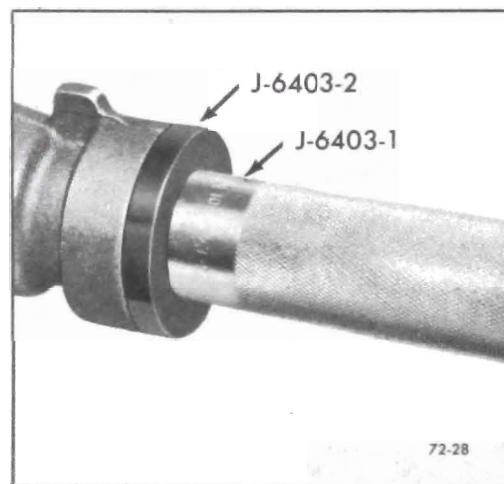

Figure 72-28 - Installing
Rear Bearing Retainer Oil
Seal

11. Install retaining snap ring.

12. Install front main bearing retainer, gasket and four (4) attaching bolts, torque 8-12 lb.ft.

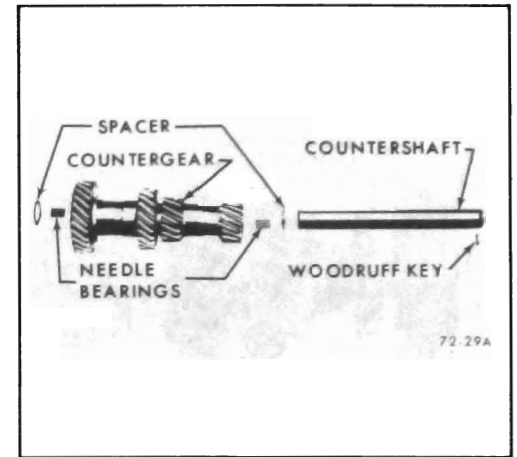

Figure 72-29 - Exploded
View of Countergear

NOTE: The retainer oil return hole must be positioned toward bottom of case.

13. Install reverse idle gear "E" ring.

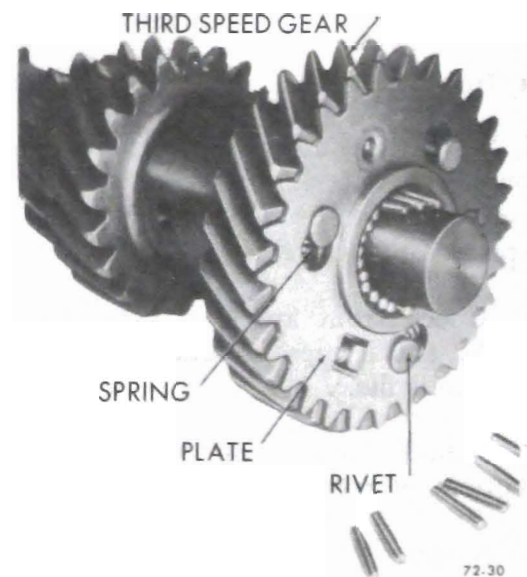

Figure 72-30 - Anti-rattle
Gear

14. Install new side cover gasket. Place transmission in neutral and install side cover. Install attaching bolts and tighten evenly to avoid side cover distortion. Torque 8-12 lb.ft.

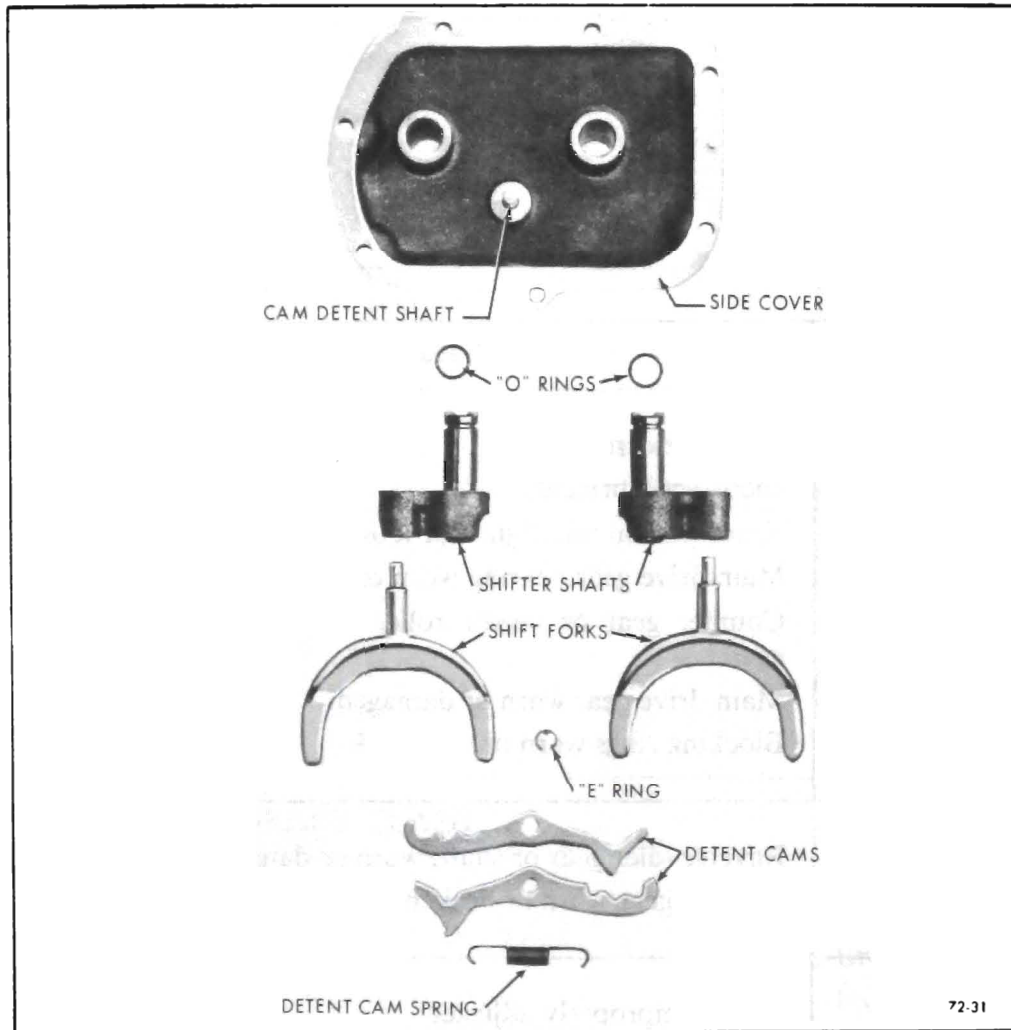

Figure 72-31 - Exploded View of Side Cover

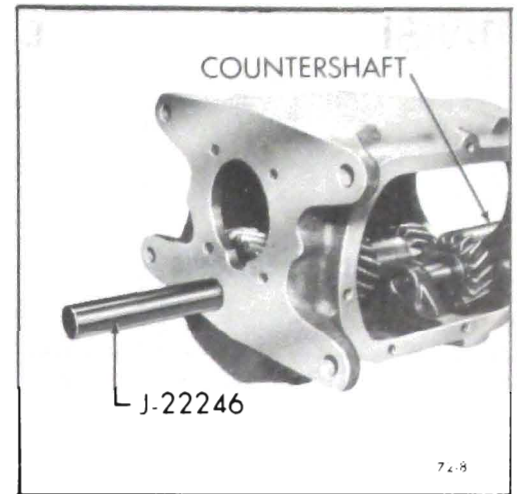

Figure 72-34 - Installing Counter gear Shaft

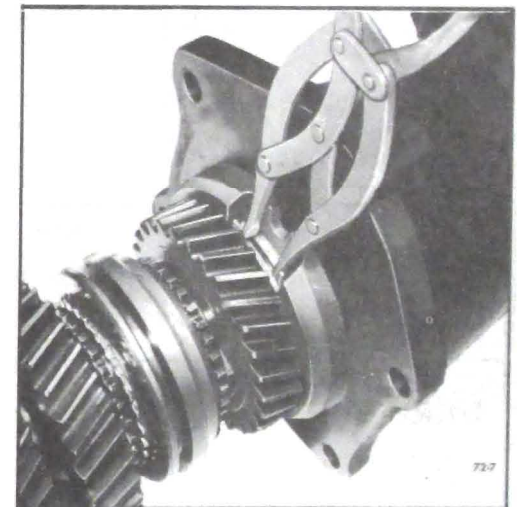

Figure 72-35 - Installing Rear Bearing Retainer

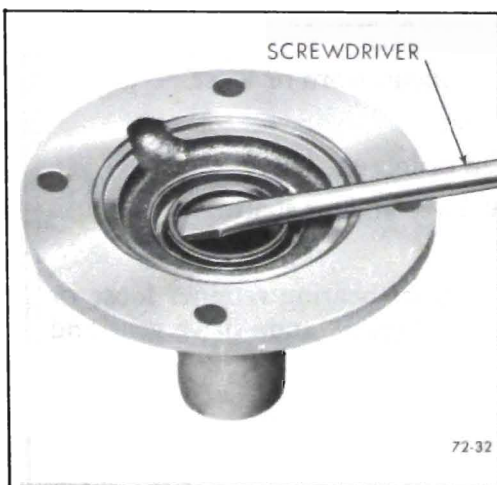

Figure 72-32 - Removing Front Bearing Retainer Seal

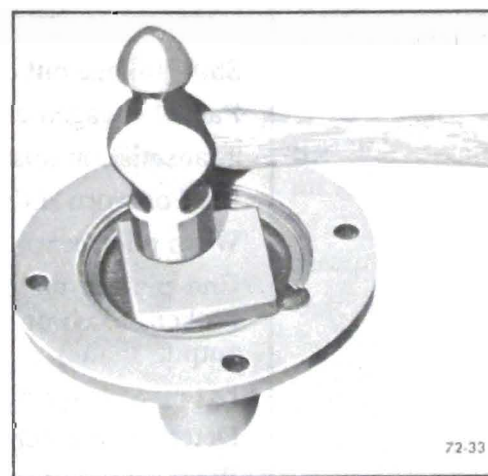

Figure 72-33 - Installing Front Bearing Retainer Seal

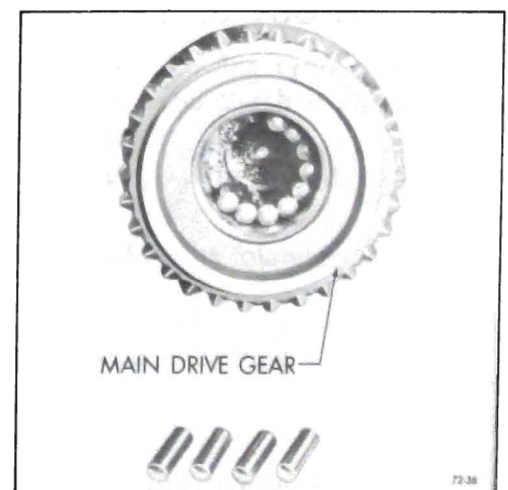

Figure 72-36 - Installing Needle Roller Bearings

DIVISION IV TROUBLE DIAGNOSIS**72-12 TROUBLE DIAGNOSIS**

Complaint	Probable Cause
NOISY IN FORWARD SPEEDS	<p>Low lubricant level.</p> <p>Incorrect lubricant.</p> <p>Transmission misaligned or loose.</p> <p>Main drive gear bearing worn or damaged.</p> <p>Counter gear or needle roller bearings worn or damaged.</p> <p>Main drive gear worn or damaged.</p> <p>Blocking rings worn or damaged.</p>
NOISY IN REVERSE	<p>Reverse idler gear or shaft, worn or damaged.</p> <p>Reverse gear worn or broken.</p>
HARD SHIFTING	<p>Clutch improperly adjusted.</p> <p>Shift linkage out of adjustment.</p> <p>Bent, damaged, or loose shift linkage.</p> <p>Shift levers, shafts, or forks worn.</p> <p>Incorrect lubricant.</p> <p>Blocking rings worn or broken.</p>
JUMPING OUT OF GEAR	<p>Shift linkage out of adjustment, worn or loose.</p> <p>Partial engagement of gear.</p> <p>Transmission misaligned or loose.</p> <p>Bent or worn shift fork, lever and/or shaft.</p> <p>Worn pilot bearing.</p> <p>End play in main drive gear (bearing retainer loose or broken, loose or worn bearings on main drive gear and output shafts).</p> <p>Detent cam spring weak.</p> <p>Detent cam notches worn.</p> <p>Worn clutch teeth on main drive gear and/or worn clutch teeth on synchronizer sleeve.</p> <p>Worn or broken blocking ring.</p> <p>Bent output shaft.</p>

DIVISION IV TROUBLE DIAGNOSIS

72-12 TROUBLE DIAGNOSIS (Cont'd.)

Complaint	Probable Cause
STICKING IN GEAR	Clutch not releasing fully. Low lubricant level. Incorrect lubrication. Corroded transmission levers (shaft). Tight main drive gear pilot bearing. Frozen synchronizing blocking ring on main drive gear cone. Burred or battered teeth on synchronizer sleeve and/or main drive gear.
FORWARD GEARS CLASH	Clutch not releasing fully. Weak or broken springs in the synchronizer assembly. Worn blocking rings and/or cone surfaces. Broken blocking rings. Excessive rock of synchronizer assembly on mainshaft.
GEARS SPINNING WHEN SHIFTING INTO GEAR FROM NEUTRAL	Clutch not fully releasing. Binding main drive gear pilot bearing. Synchronizers not functioning.
REVERSE GEAR CLASH	Allow approximately three - four seconds after the clutch pedal has been depressed before shifting into reverse gear. If gear clash continues after allowing proper time for the clutch plate to stop, check the clutch adjustment to make sure that it is within specifications. Make sure that the engine idle speed is set to specifications. Gear clash can also be caused by the following: Dragging clutch driven plate. Distorted clutch driven plate. Tight or frozen main drive gear bearing.
SCORED OR BROKEN GEAR TEETH	Insufficient lubricant. Failure of the car operator to fully engage the gears on every shift before engaging the clutch and applying engine power.

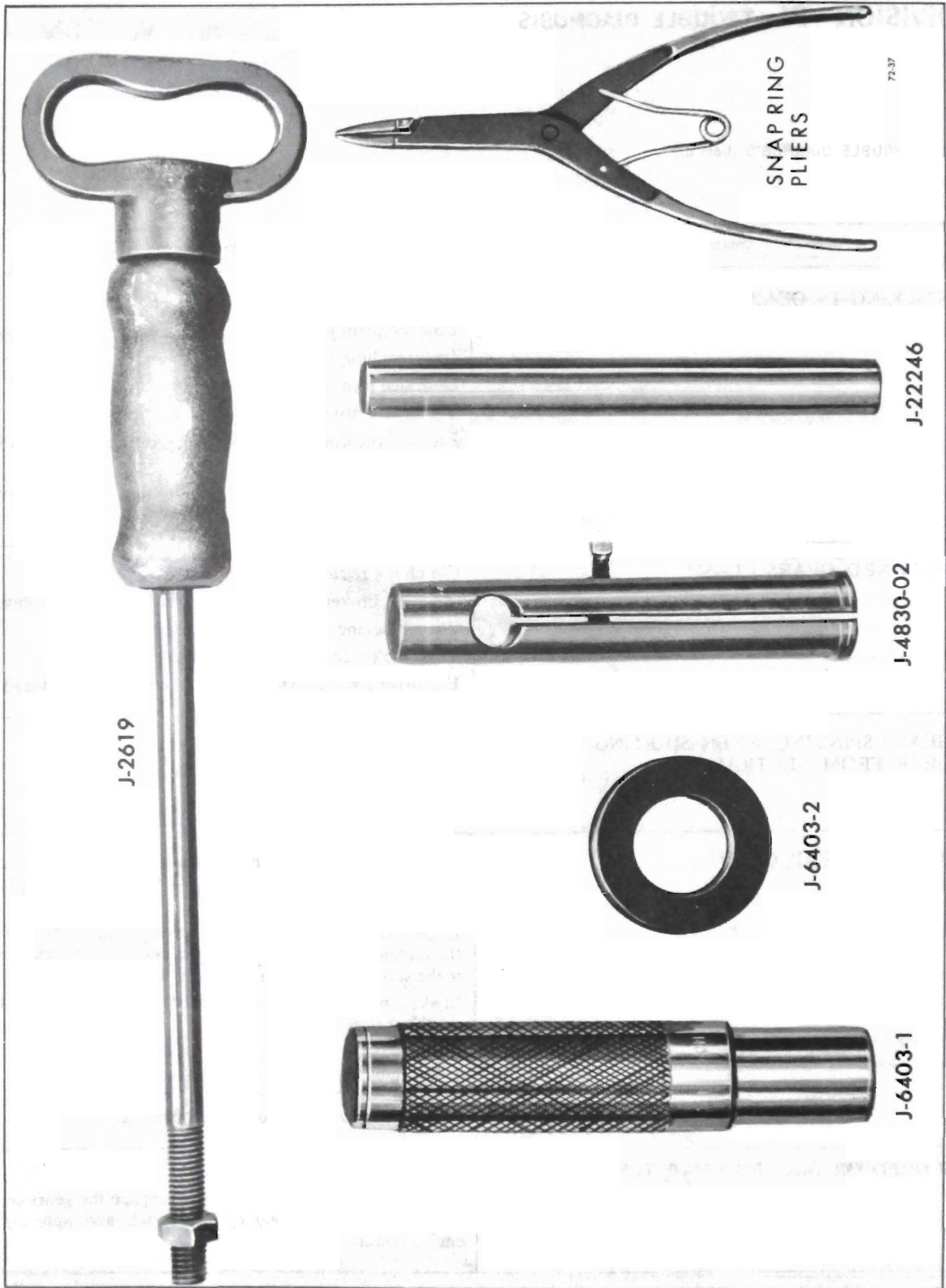

Figure 72-37 · Tool Picture