

# CONTROLLED COMBUSTION SYSTEM

## CONTENTS

| Division | Subject                                                                                                                                         | Paragraph    |
|----------|-------------------------------------------------------------------------------------------------------------------------------------------------|--------------|
| I        | SPECIFICATIONS AND ADJUSTMENTS:<br>Controlled Combustion System Specifications . . . . .                                                        | 67-1         |
| II       | DESCRIPTION AND OPERATION:<br>Description and Operation of Controlled Combustion System and<br>Transmission Controlled Vacuum Advance . . . . . | 67-2         |
| III      | SERVICE PROCEDURES:<br>Removal and Replacement of Units . . . . .                                                                               | 67-3         |
| IV       | TROUBLE DIAGNOSIS:<br>Testing Thermo Air Cleaner Operation . . . . .<br>Testing Transmission Controlled Vacuum Advance . . . . .                | 67-4<br>67-5 |

## DIVISION I—SPECIFICATIONS AND ADJUSTMENTS

### 67-1 CONTROLLED COMBUSTION SYSTEM SPECIFICATIONS

|                                                      |            |
|------------------------------------------------------|------------|
| Carburetor Inlet Air Regulated Temperature . . . . . | 115° ± 20° |
| Idle Mixture Setting (Lean from Best Idle) . . . . . | 20 RPM     |
| Thermo Vacuum Switch Operating Temperature . . . . . | 220°       |
| Engine Thermostat Operating Temperature              |            |
| L-6 Engine . . . . .                                 | 195°       |
| V-8 Engine . . . . .                                 | 190°       |

| Idle Speed and Ignition Timing                  | Fast Idle Speed<br>(On Low Step of Cam) | Idle Speed<br>(Drive Range with AC Off) | Ign. Timing  |
|-------------------------------------------------|-----------------------------------------|-----------------------------------------|--------------|
| 250 Eng. — Manual Transmission . . . . .        | 900                                     | 750 (Neut.)                             | 0° or T.D.C. |
| 250 Eng. — Automatic Transmission . . . . .     | 650                                     | 600 (AICCA)                             | 4° B.T.D.C.  |
| 350 Eng. — Manual Transmission . . . . .        | 720                                     | 700 (Neut.)                             | 6° B.T.D.C.  |
| 350 Eng. — Automatic Transmission . . . . .     | 650                                     | 600                                     | 6° B.T.D.C.  |
| 455 Eng. — Manual Transmission . . . . .        | 720                                     | 700 (Neut.)                             | 6° B.T.D.C.  |
| 455 Eng. — Automatic Transmission . . . . .     | 650                                     | 600                                     | 6° B.T.D.C.  |
| 455 Eng. — Stage 1 Auto. Transmission . . . . . | 650                                     | 600                                     | 10° B.T.D.C. |
| 455 Eng. — Stage 1 Man. Transmission . . . . .  | 720                                     | 700 (Neut.)                             | 10° B.T.D.C. |

67A-2

## DIVISION II

### DESCRIPTION AND OPERATION

#### 67-2 DESCRIPTION AND OPERATION OF CONTROLLED COMBUSTION SYSTEM

All 1970 cars must be capable of passing certain tests which measure the quantity of unburned impurities in the exhaust gases. Federal law places a limit on the hydrocarbon and carbon monoxide emissions from the exhaust system. The purpose of this law is to keep the atmosphere cleaner, particularly in

populous areas where these impurities add to the smog problem.

Basically, excessive exhaust emissions are caused by incomplete combustion of the air-fuel mixture in the cylinders.

In order to pass the stricter 1970 Federal emissions requirements, all

250 cu. in. and 455 cu. in. engines will have a transmission controlled vacuum advance control system; and the controlled combustion system.

The Controlled Combustion System and Transmission Controlled Vacuum Advance are used with engines designed for no spark advance at lower engine speeds plus leaner carburetor and choke calibrations. With retarded idle timing, the throttle must be opened slightly more to maintain the same idle speed. This gives better mixture distribution and less exhaust dilution, resulting in much more complete combustion.

All 1970 Buicks, therefore, have "ported" spark advance, with the vacuum take-off just above the throttle valve, so that there is no vacuum advance at closed throttle. The transmission controlled vacuum advance system consists of a solenoid valve (inserted in the ported vacuum hose to the distributor), an oil pressure operated switch (installed in the transmission) and an electrical harness connecting these two units.

The solenoid valve is normally open but closes off vacuum when electricity flows through the solenoid. A vent bleeds off any vacuum in the hose to the distributor advance unit when the valve closes.

The oil pressure switch is located internally in the direct clutch circuit and is pressurized when the car has shifted into third or drive gear.

The oil pressure switch is normally closed but opens to stop electrical flow to ground when there is oil pressure to the switch. The switch is controlled by direct clutch apply pressure.

An electrical harness connects the ignition switch to one terminal of the solenoid valve, through the solenoid, out the other solenoid terminal and to ground thru the oil pressure switch (when closed).

Operation of the transmission controlled vacuum advance system is as follows:

1. When operating in P, N, L2, or L1 positions, there is no oil pressure in the direct clutch circuit to the transmission switch, so there can be no vacuum advance.
2. When operating in D, there is no oil pressure to the transmission switch until the transmission upshifts to third gear, at which time vacuum advance starts to operate normally.
3. When operating in R, there is always oil pressure in the direct clutch circuit to the transmission switch, so there is normal vacuum advance.

Because of the greater heat rejection to the coolant during idle with little vacuum spark advance, some engines are liable to overheat if allowed to idle for an extended period. For this reason, all upper series and 455 cu. in. automatic transmission engines have a thermo vacuum switch located in the coolant passage at the left front corner of the intake manifold. This vacuum switch has three nipples:

1. The nipple marked "MT" has a hose either directly to the intake manifold or to a tee which connects to the manifold.
2. The nipple marked "C" is connected to the carburetor for a "ported" vacuum source.
3. The nipple marked "D" is connected to the distributor vacuum advance unit.

When engine coolant is at normal temperatures, the thermo vacuum switch (not included on manual transmission equipped cars and on 350 cu. in. engine equipped lower series cars) is positioned internally to supply "ported" vacuum to the distributor. However, if coolant temperature should ever rise above 220 degrees, the thermo vacuum switch will supply full intake mani-

fold vacuum to the distributor, even at closed throttle. This will improve idle quality and will cause an idling engine to speed-up, resulting in improved fan and water pump action, besides reducing heat rejection to the coolant because of the 14 to 18 degrees spark advance.

The C.C.S. package includes leaner carburetor calibration at idle and part throttle plus leaner choke calibration. Since past model carburetion was as lean as possible consistent with good driveability with inlet air temperatures as low as -20 degrees, this still leaner C.C.S. carburetion is only possible because of the heated air system that is also a part of the C.C.S. package. See Figure 67-1. With the heated air system operating, inlet air temperature is around 115 degrees after the first few minutes of operation; this makes use of leaner (hot weather) calibration possible, and the car still responds and drives well in cold weather.

The heated air part of the C.C.S. consists of a heat stove, a corrugated paper heated-air pipe, a plastic adapter elbow and an air cleaner containing temperature control doors operated by vacuum through a temperature sensor.

The heat stove is a sheet metal cover, shaped to and bolted on with the left exhaust manifold. Air drawn in along the lower edge of the stove passes across the manifold surface, picking-up heat. The heated air is drawn out from the upper center of the manifold, through the heated air pipe and plastic adapter elbow into the snorkel of the air cleaner.

The temperature control air cleaner is designed to mix this heated air with cold air from under the hood so that carburetor inlet air temperature averages about 115°. This mixing is done by two air doors, a cold air door and a hot air door, which move together so that when the cold air door is closed, the hot air door is open and vice versa. Most of the time, both doors will be partially

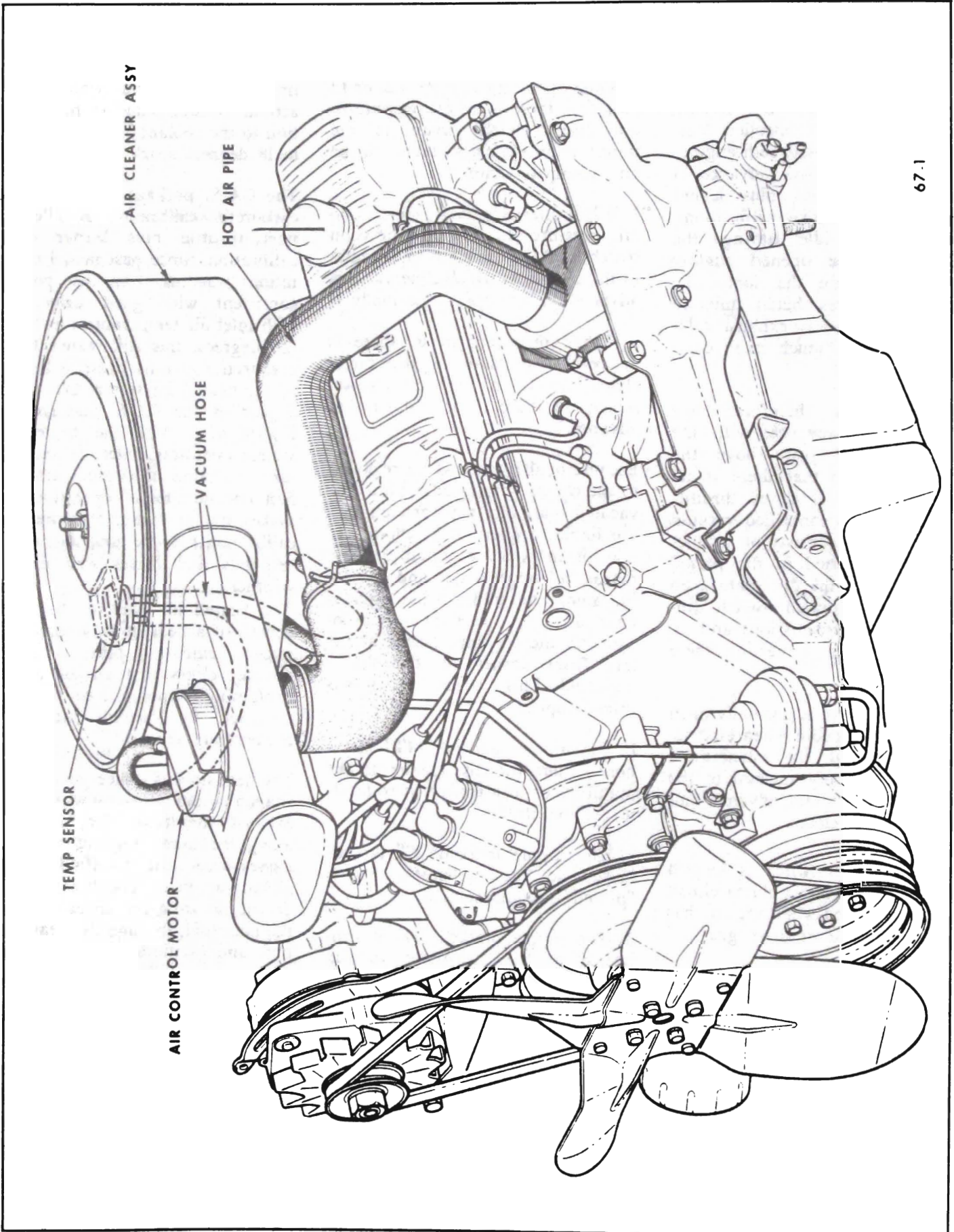

Figure 67-1 - Heated Air System Installed

open as required to control the temperature. When the underhood temperature reaches about 135°, the cold air door will open wide and the hot air door will close tight. See Figure 67-2. Obviously, if underhood temperatures rise above 135 degrees, the air cleaner will no longer be able to control temperature and the inlet air temperature will with rise underhood temperature.

The temperature doors are moved by a diaphragm type vacuum motor. When there is no vacuum present in the motor, the diaphragm spring forces the cold air door open and the hot air door closed. Whenever the engine is running, the amount of vacuum present in the vacuum motor depends on the temperature sensor in the air cleaner which is located in the vacuum line between the intake manifold and the vacuum motor. In the sensor, a bi-metal temperature sensing spring starts to open a valve to bleed more air into the vacuum line whenever the temperature in the air cleaner rises above about 115°. Whenever the temperature falls below about 115 degrees, the sensing spring starts to close the air bleed into the vacuum line, allowing more manifold vacuum to reach the vacuum motor. Whenever there is 9 inches or more of vacuum in the vacuum motor, the diaphragm spring is compressed, the cold air door is closed and the hot air door is opened.

When the engine is not running, the diaphragm spring will always hold the cold air door open and the hot air door closed. However, when the engine is running, the position of the doors depends on the air temperature in the air cleaner.

When starting a cold engine (air cleaner temperature under 85 degrees), the cold air door will close and the hot air door will open immediately. See Figure 67-3. This is because the air bleed valve in the sensor is closed so that full manifold vacuum, is applied in the vacuum motor. The cold air door will remain tightly closed only a few minutes,

however. As soon as the air cleaner starts receiving hot air from the heat stove, the sensor will cause the cold air door to open partially, mixing cold air with the hot air as necessary to regulate air cleaner temperature within 20° of the ideal 115 degrees air inlet temperature. See Figure 67-4

If underhood air temperature rises to 135 degrees, the air bleed valve in the sensor will be wide open so that vacuum to the vacuum motor approaches zero. The diaphragm spring in the vacuum motor will hold the cold air door wide open and close the hot air door tightly. If underhood temperature rises above 135 degrees, carburetor inlet air temperature will also rise above 135 degrees.

While air cleaner temperature is being regulated, accelerating the engine hard will cause the vacuum level in the intake manifold and in the vacuum motor to drop. Whenever vacuum drops below 5 inches, the diaphragm spring will open the cold air door wide in order to get the maximum air flow required for maximum acceleration.

With an L-6 engine, a different air cleaner controls the inlet air temperature 10 degrees lower than the V-8 engines. On L-6 engines, ideal inlet air temperature is 105 degrees plus or minus 20 degrees.

## DIVISION III

### SERVICE PROCEDURES

#### 67-3 REMOVAL AND REPLACEMENT OF C.C.S. UNITS

**NOTE:** *The damper door is not serviceable. The air cleaner assembly must be replaced if the damper door is defective.*

##### a. R and R Vacuum Motor

1. Drill center of two spot welds using a 1/16 inch drill. Do not center punch.

2. Enlarge two holes using a 5/32 inch drill.

**CAUTION:** *Use extreme care not to damage the air cleaner snorkel.*

3. Remove vacuum motor retainer strap. See Figure 67-5.

4. Lift vacuum motor, cocking it to one side to unhook motor linkage at the control door.

5. Drill a 7/64" hole in snorkel tube at point "A" as shown in Figure 67-5.

6. Use the motor strap retainer and the sheet metal screw provided in the motor service package to secure the retainer and motor to the snorkel tube.

7. Make sure the screw does not interfere with the operation of the damper assembly. Shorten screw if required.

##### b. R and R Air Cleaner Sensor

1. Remove two sensor retaining clips by prying. See Figure 67-6.

2. Pull vacuum hoses from sensor.

3. Note carefully the installed position of the sensor so that you can install new sensor in same position. Then remove sensor.

4. Install sensor and gasket assembly in air cleaner in same position as noted in Step 3. This is to eliminate the possibility of interference with the air filter element. See Figure 67-5.

5. Install sensor retaining clip. Meanwhile supporting sensor at "B" around the outside rim to prevent damage to the temperature sensing spring. See Figure 67-5.

6. Reinstall vacuum hoses.



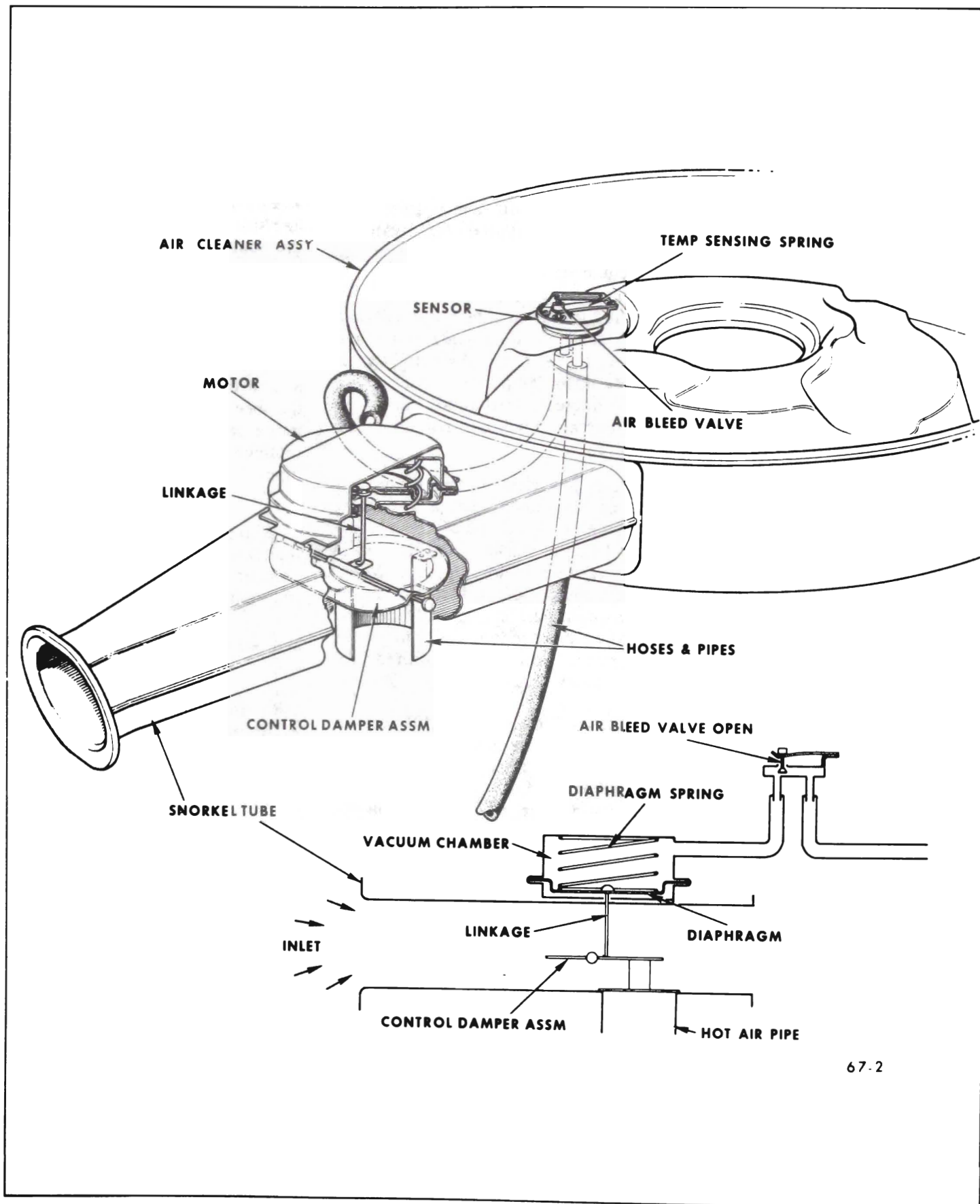

Figure 67-2 - Cold Air Door Open

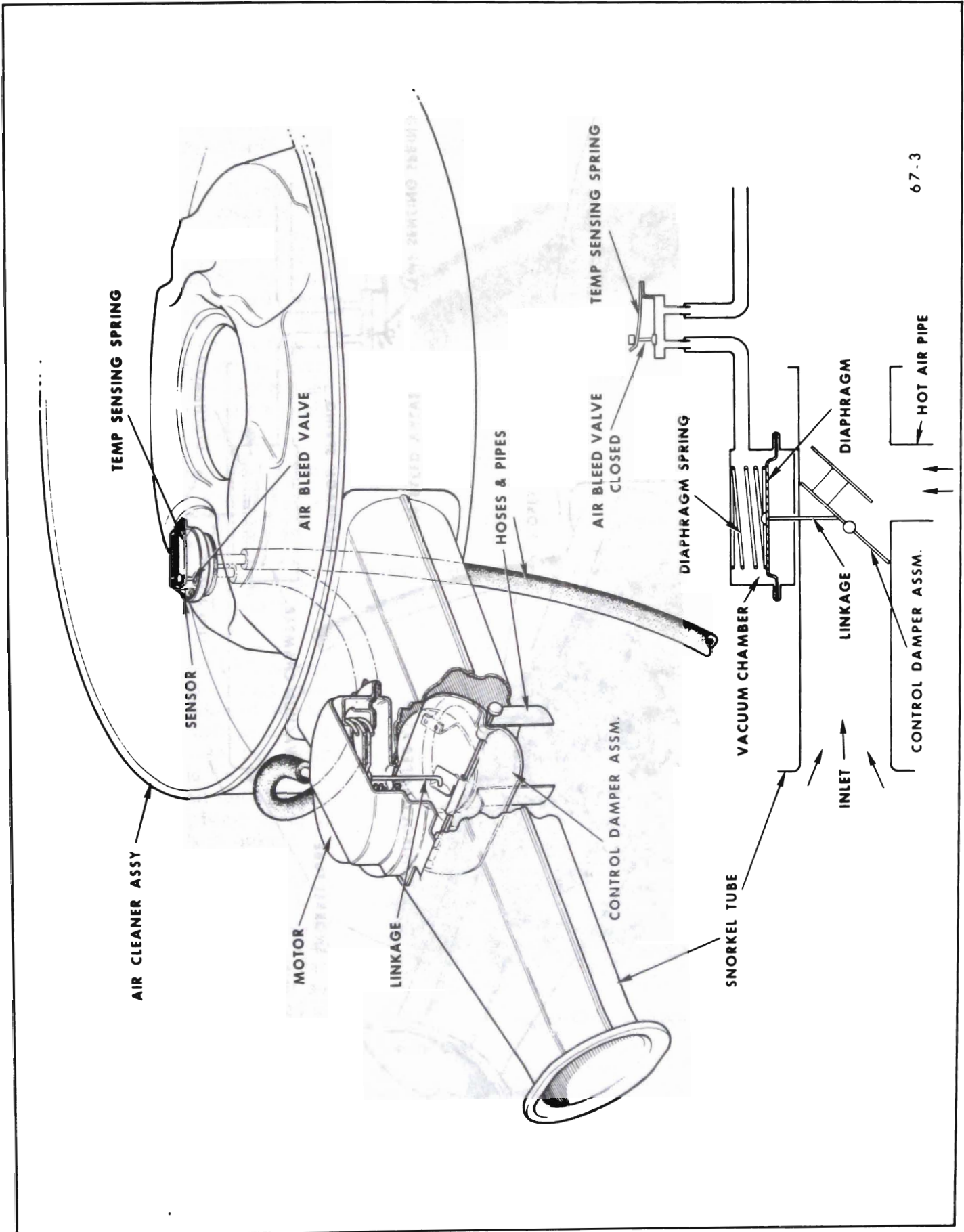

Figure 67-3 · Hot Air Door Open

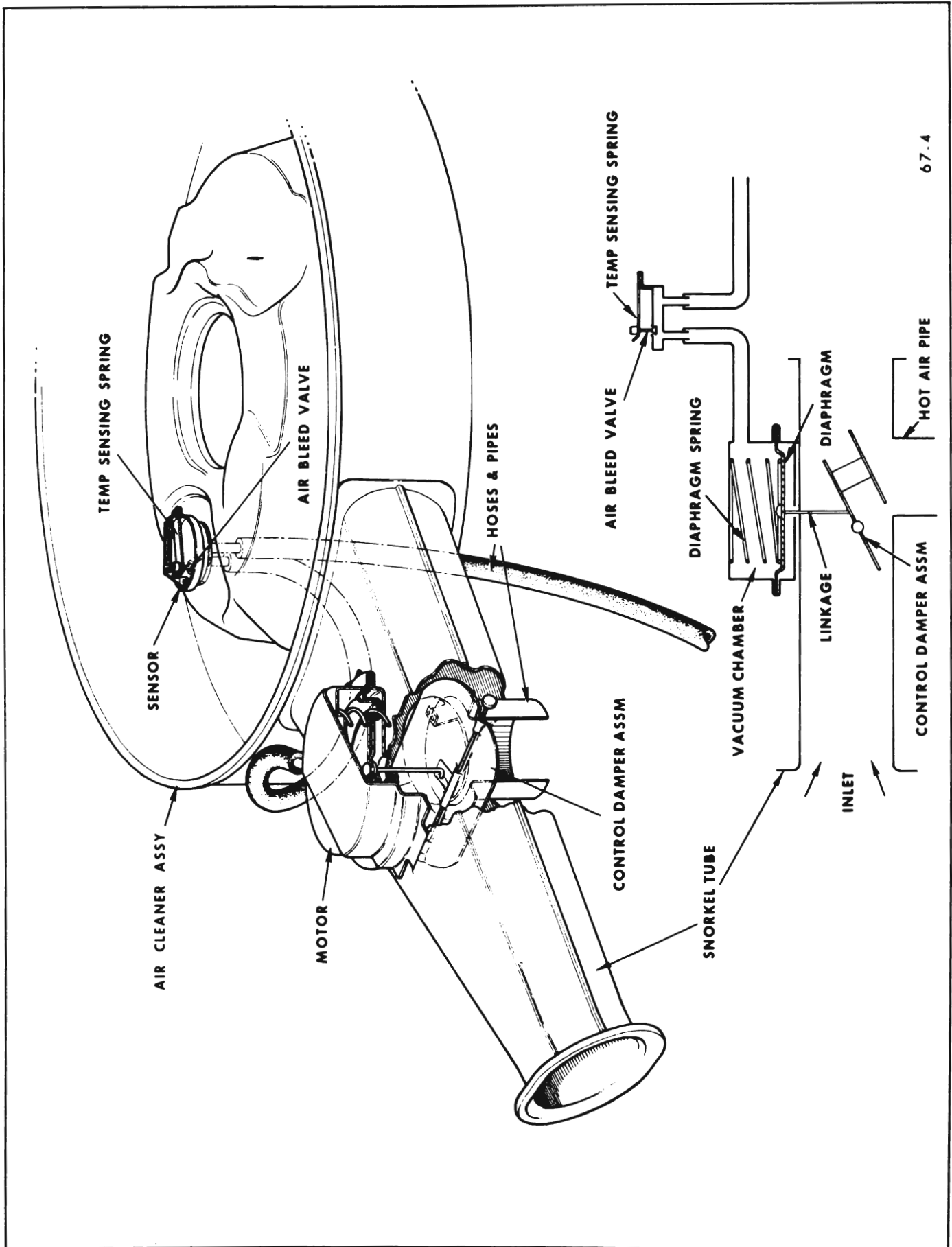

Figure 67-4 - Cold and Hot Air Doors Both Partially Open

## DIVISION IV

### TROUBLE DIAGNOSIS

#### 67-4 TESTING THERMO AIR CLEANER OPERATION

Since failure of the thermo air cleaner will generally result in the snorkel cold air door staying open, failure will probably go unnoticed in warm or hot weather. In cold weather, however, owners will complain of leanness, hesitation, sag, surge or stalling. When any type of lean operation complaint is received, always test the thermo air cleaner for proper functioning before doing any work on the carburetor.

**NOTE:** Always perform checks in the same order as listed below.

##### a. Vacuum Motor Check

1. Check all hoses for proper hook-up. Check for kinked, plugged or damaged hoses.
2. With the engine "OFF", observe damper door position through snorkel opening. If position of snorkel makes observation difficult use the aid of a mirror. At this point damper door should be in such a position that the heat stove passage is covered (snorkel passage open). If not, check for binds in linkage.
3. Apply at least 9 in. Hg. of vacuum to diaphragm assembly through hose disconnected at sensor unit. This can be done by mouth. Damper door should completely close snorkel passage when vacuum is applied. If not check to see if linkage is hooked up correctly and for a vacuum leak.

4. With vacuum applied, bend or clamp hose to trap vacuum in diaphragm assembly. Damper door should remain in position (closed snorkel passage). If it does not, there is a vacuum leak in diaphragm assembly. Replace diaphragm assembly.

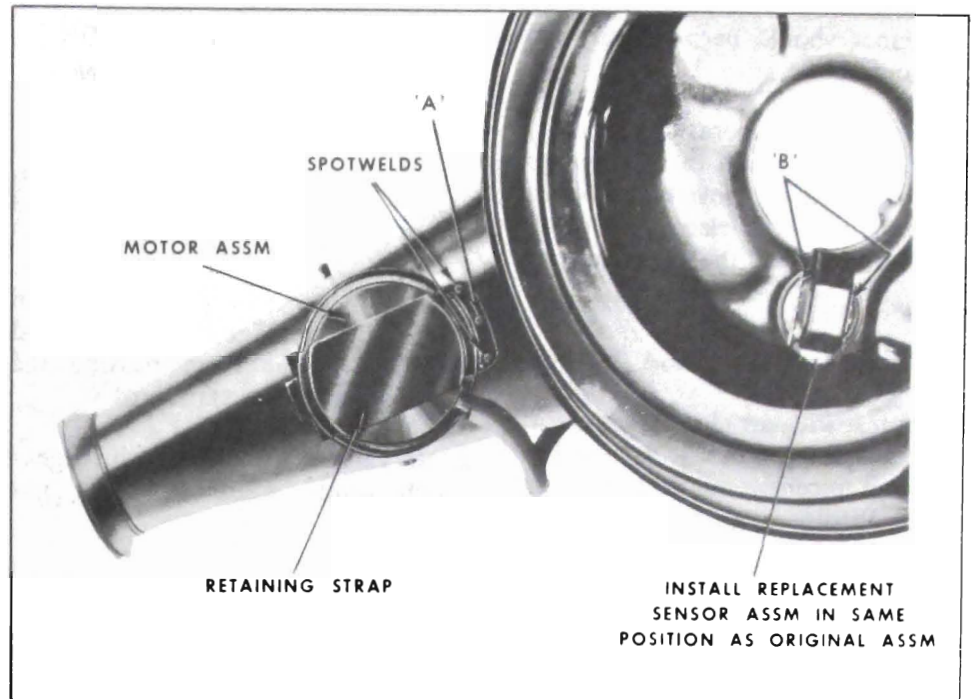

Figure 67-5 - Replacing Vacuum Motor Assembly

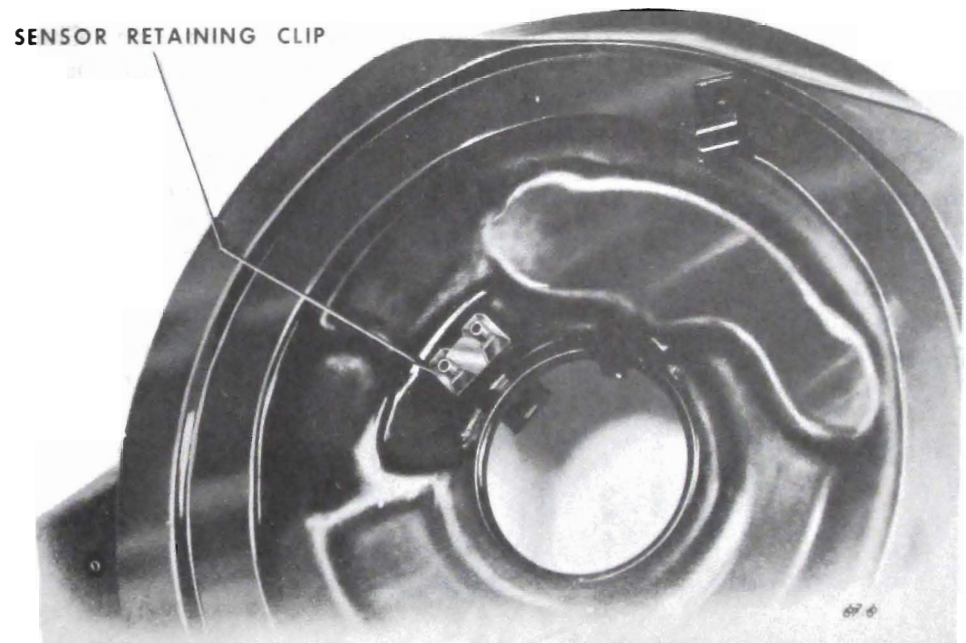

Figure 67-6 - Replacing Sensor Assembly

##### b. Sensor Check

###### Quick Check of System:

1. Start test with engine cold, air cleaner at a temperature below 85 degrees. If the engine has been in recent use, allow it to cool.
2. Observe the cold air door before

starting the engine: it should be wide open.

3. Start the engine and allow it to idle. Immediately after starting the engine, the cold air door should close.

4. As the engine warms up, the cold air door should start to open and the



air cleaner should become warm to the hand.

5. The system is operating normally as described above. If the air cleaner fails to operate as above or if correct operation of the air cleaner is still in doubt, proceed to the thermometer check.

#### Thermometer Check of Sensor:

1. Start test with air cleaner temperature below 85 degrees. If engine has been run recently, allow it to cool down. While engine is cooling, remove air cleaner cover and install a temperature gage such as J-22973 as close as possible to sensor. Reinstall air cleaner cover. Do not install wing nut. Let car stand idle for 1/2 hour or more before proceeding to step 2.

2. Start and idle engine. Cold air door should close immediately if engine is cool enough. When cold air door starts to open (in a few minutes), remove air cleaner cover and read temperature gage. It must read 115 degrees plus 20 degrees. (L-6 engine -- 105 degrees plus or minus 20 degrees.)

3. If cold air door does not start to open at temperature indicated, temperature sensor is defective and must be replaced.

### 67-5 TESTING TRANSMISSION CONTROLLED VACUUM ADVANCE

A failure in the transmission controlled vacuum advance system could result in either of two troubles:

1. Continuous vacuum advance in first and second gears which would prevent the car from passing the Federal emissions standards.

2. No vacuum advance in third gear which would result in lower gas mileage.

Check for proper operation of the transmission controlled vacuum advance system as a part of each engine tune-up, as follows:

1. With a timing light and tachometer hooked up and with transmission in D, increase engine speed to approximately 1000 RPM by positioning the fast idle cam. Check timing mark--there should be no vacuum advance.

**CAUTION:** *Make sure parking brake is applied firmly and that a wheel is blocked in front and back.*

2. Shift transmission into R. Check timing mark 1000 RPM--there should now be full vacuum advance.

A check of the vacuum retard switch can be accomplished as follows:

**CAUTION:** *To prevent damaging the pressure switch, the tester used must have sufficient resistance that it does not supply the switch with more than .8 amp of current at 12 volts. Test lamps which use size 1893 or smaller bulb, will not damage the switch.*

1. With engine running, place a continuity light on the transmission connector and to ground. The light should be on when the transmission is in "D" or drive gear.

2. Shift the transmission from drive into "R" reverse, the light in this position, should go out. If above check shows lack of continuity, a check at the output terminal of the transmission will be necessary.

3. With engine running, place a continuity light on the output terminal of the transmission, the light should be on when the transmission is in "D" or drive gear.

This is a positive check for the retard switch in the transmission only. This check shows the switch is operating as designed and further checking of the switch will not be necessary.

WITH THE CARBURETOR CLOSED AND OFF THE FAST IDLE CAM AND THE SOLENOID ENERGIZED, POSITION SOLENOID IN THE BRACKET AND SECURE IT SO THAT PLUNGER JUST TOUCHES CARBURETOR LEVER, THEN TURN CARBURETOR IDLE SPEED SCREW 1/2 TURN COUNTERCLOCKWISE.

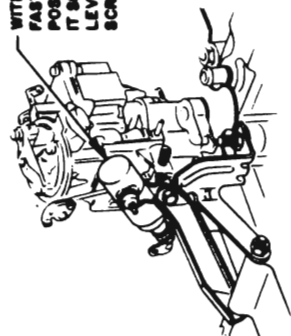

VIEW K

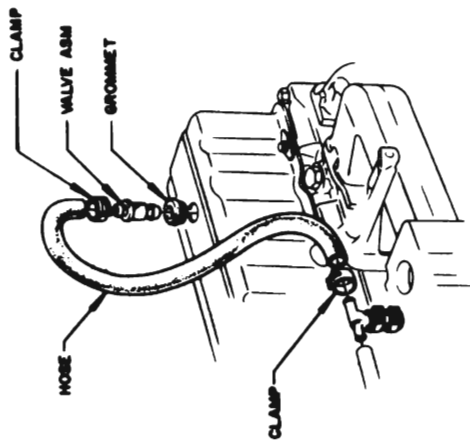

VIEW G  
CALIFORNIA ONLY

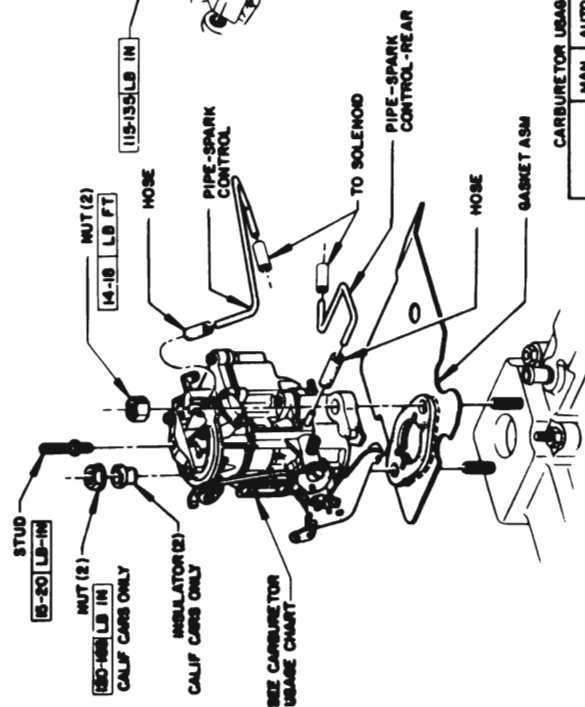

VIEW H  
CALIFORNIA ONLY

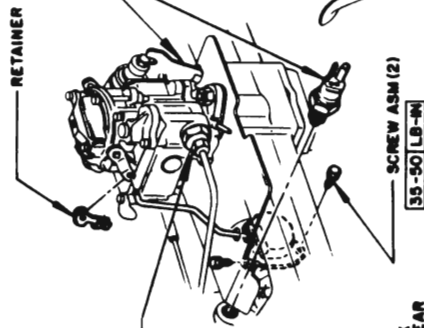

CARBURETOR USAGE CHART

|         | MAN | AUTO | A/C |
|---------|-----|------|-----|
| T040017 | ●   |      |     |
| T040034 |     |      | ●   |

SEE CARBURETOR USAGE CHART

Figure 67-7 · Heated Air System · 250 Engine (L-6)

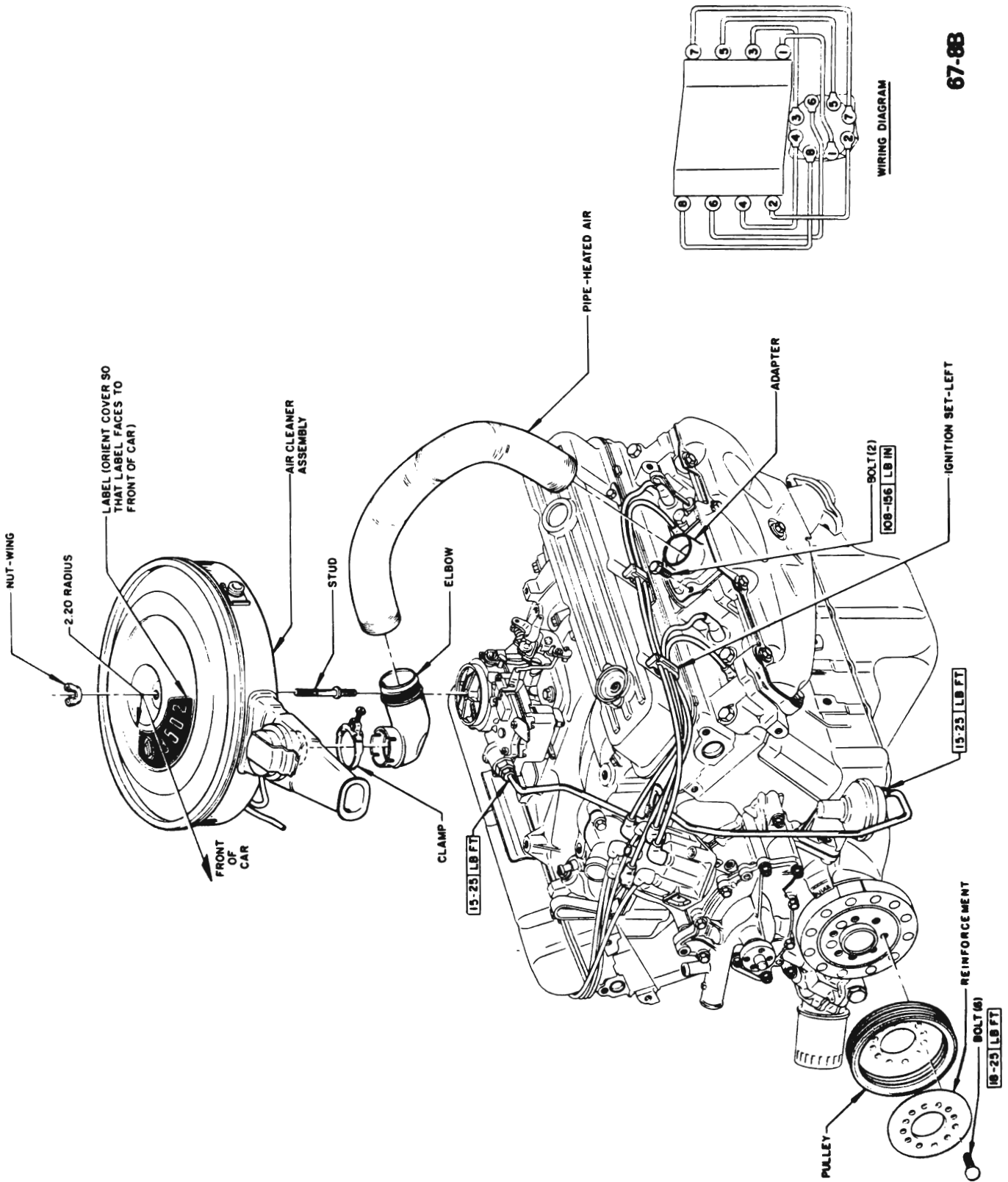

67-88

Figure 67-8 - Heated Air System - 350 2-Barrel Engine

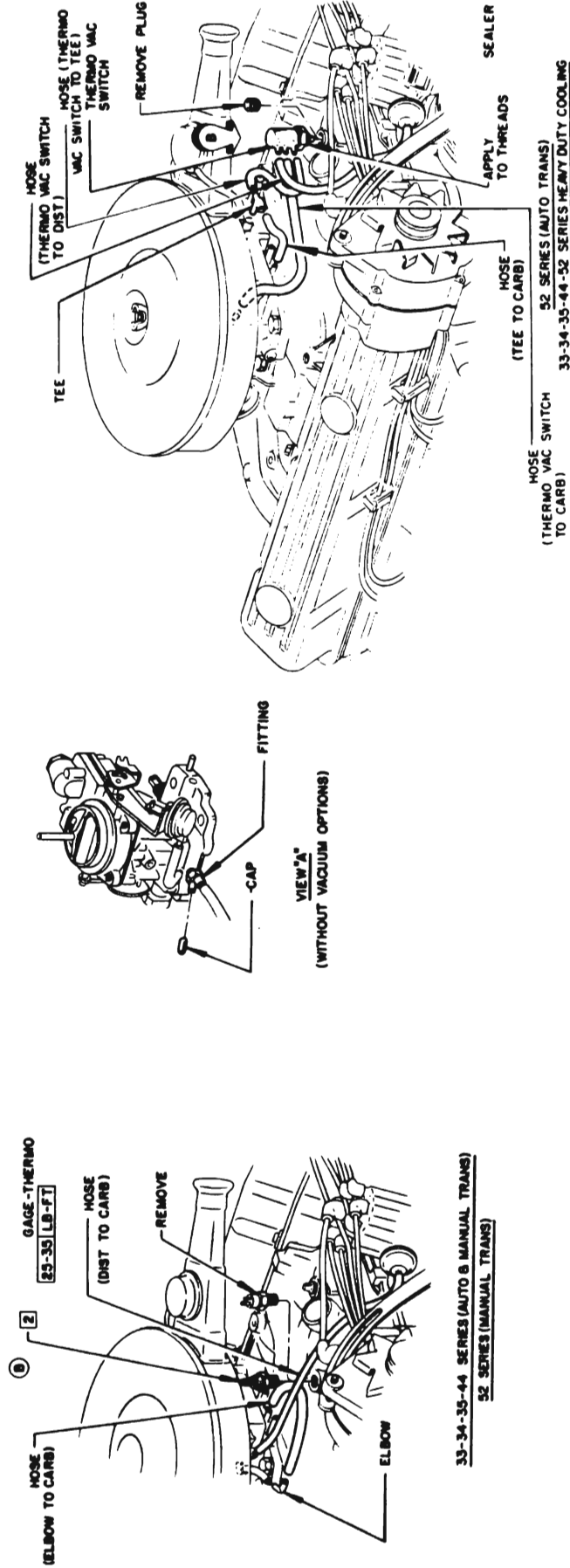

67-98

Figure 67.9 · Thermo Vacuum Switch Hose Installation · 350 2-Barrel Engine



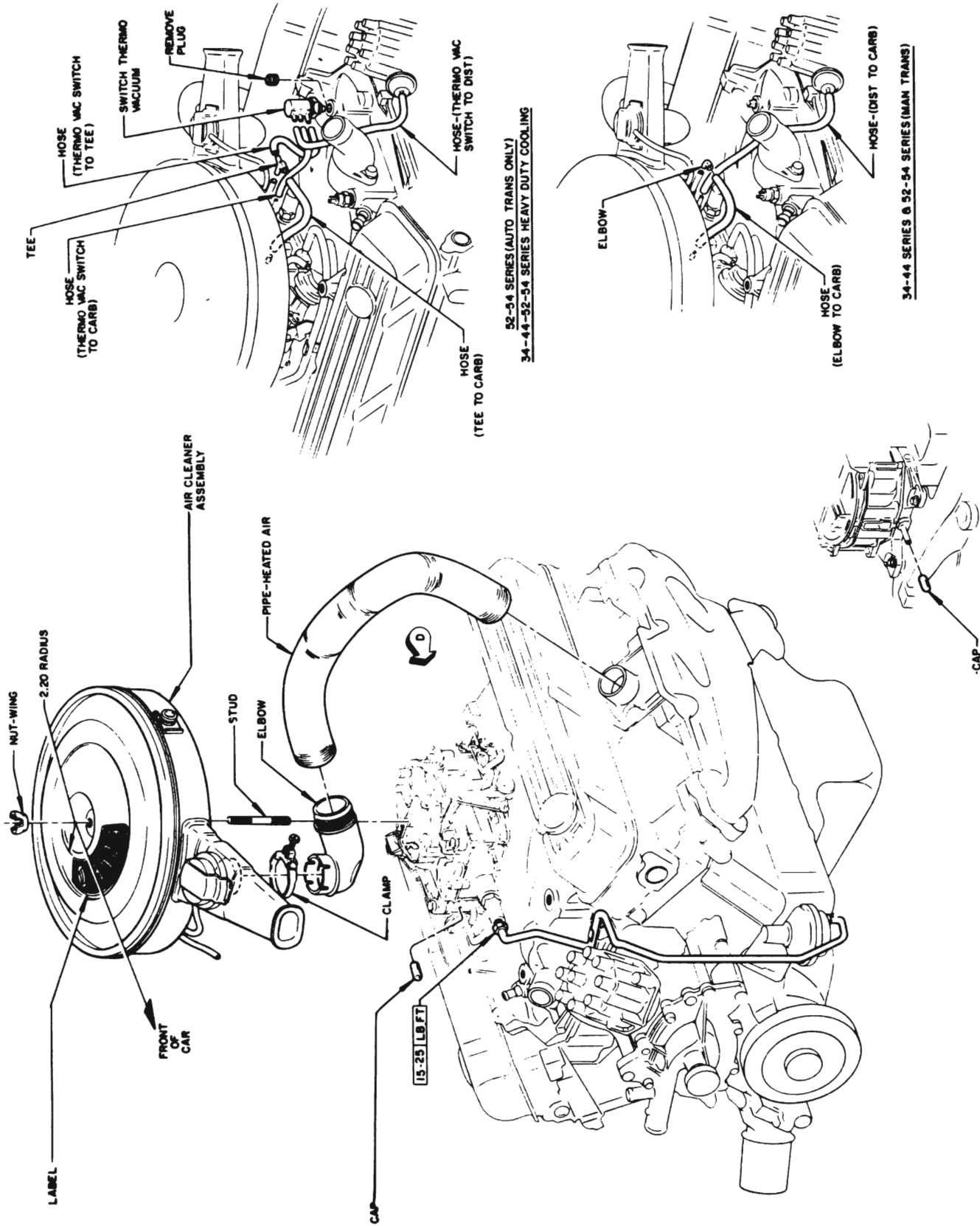

67-10B

Figure 67-10 - Heated Air System - 350 4-Barrel Engine

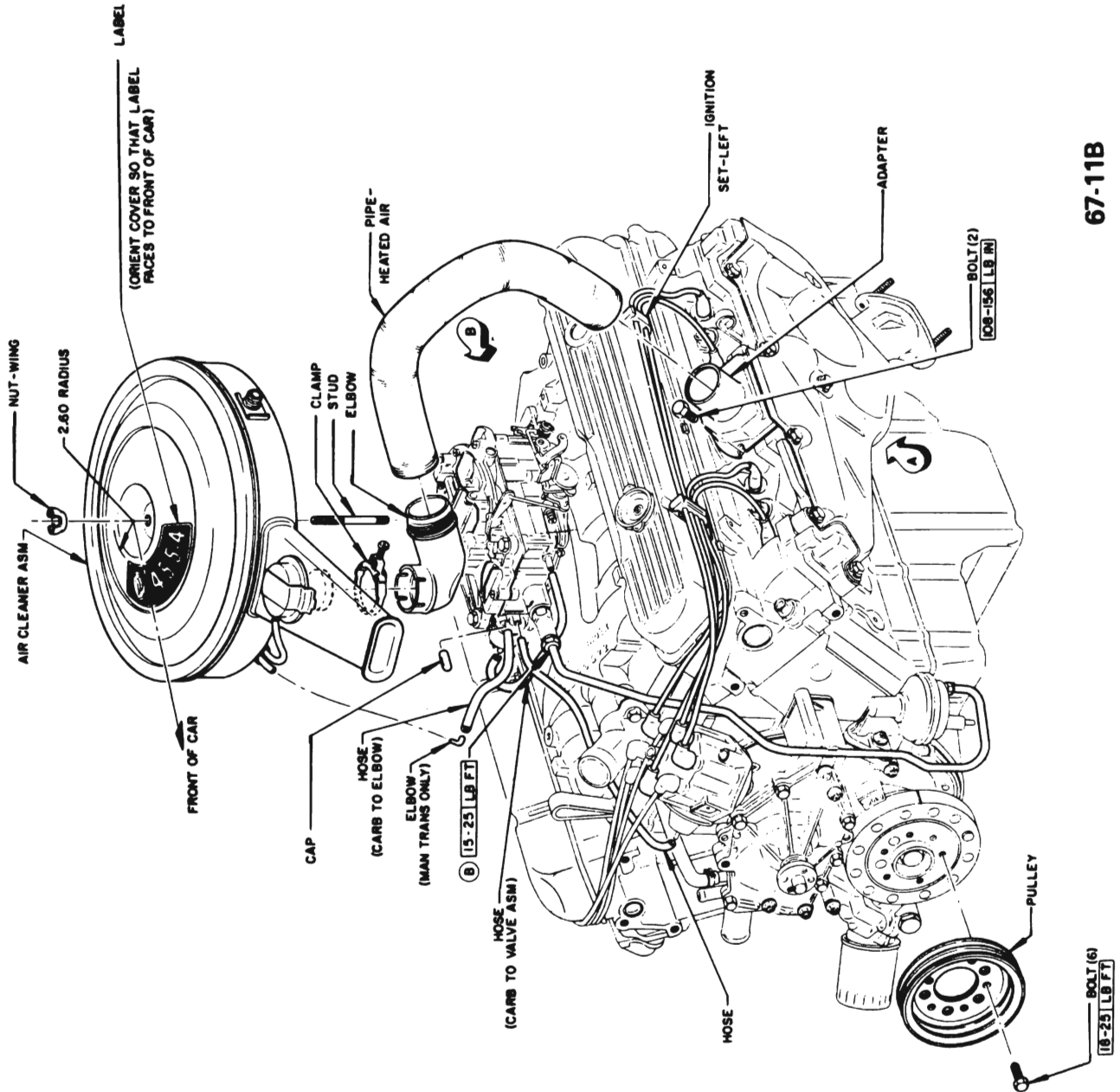

67-11B

Figure 67-11 - Heated Air System - 455 Engine

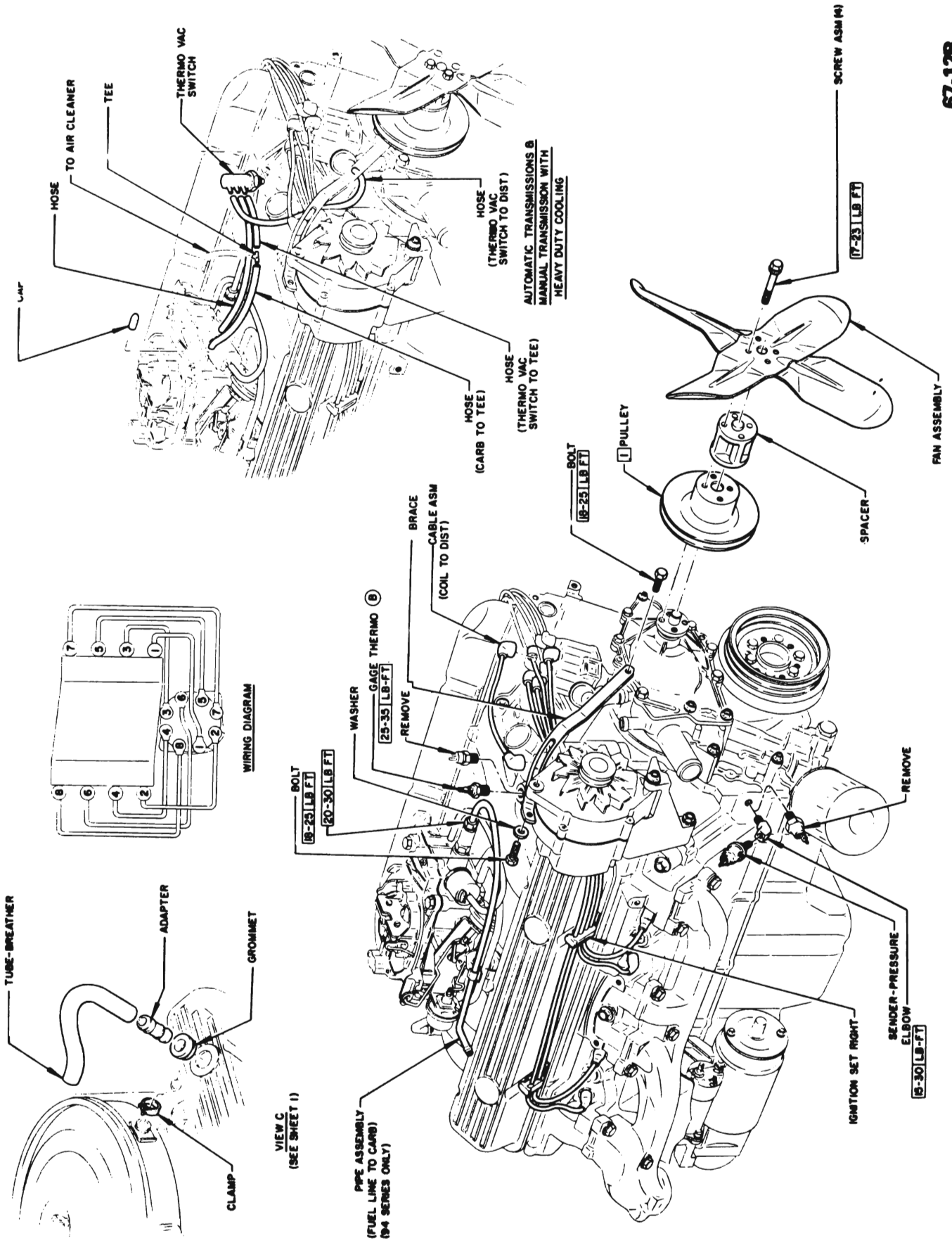
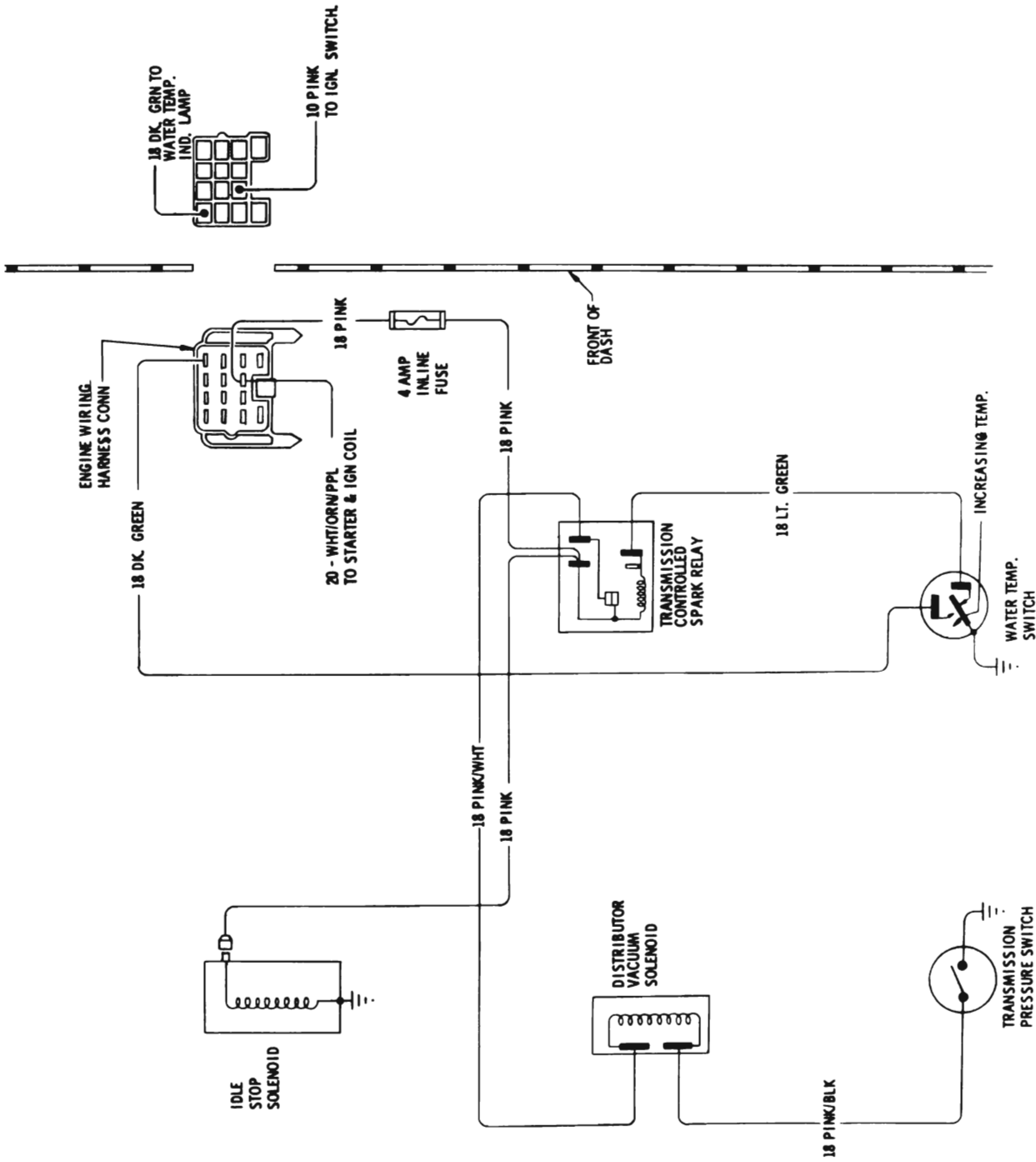

Figure 67-12 · Thermo Vacuum Switch Hose Installation · 455 Engine



67-14

Figure 67-14 - T.C.S. and Idler Stop Solenoid Wiring Diagram (L-6)



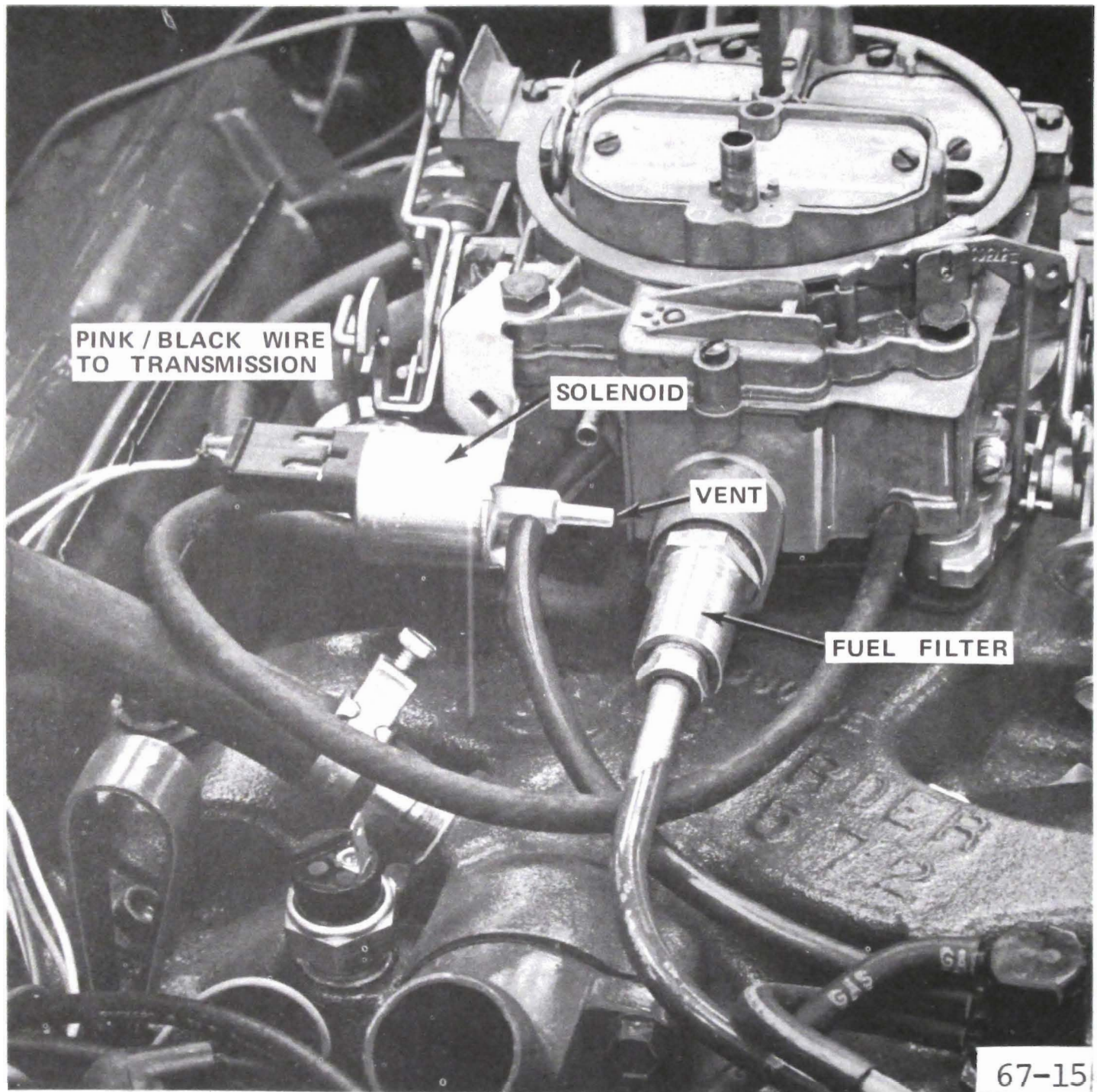

Figure 67-15 - T.C.S. Installed 455 Engine