

SECTION D

ROCHESTER 4MV CARBURETOR

CONTENTS

Division	Subject	Paragraph
I	SPECIFICATIONS AND ADJUSTMENTS:	
	Rochester 4MV Carburetor Calibrations	64-18
	Rochester 4MV Carburetor Adjustments	64-19
II	DESCRIPTION AND OPERATION:	
	Description and Operation of Rochester Quadrajets Carburetor	64-20
III	SERVICE PROCEDURES:	
	Disassembly, Cleaning and Inspection of Rochester Quadrajets Carburetor	64-21
	Assembly and Internal Adjustment of Rochester Quadrajets Carburetor	64-22
	External Adjustment of Rochester Quadrajets Carburetor	64-23

DIVISION I SPECIFICATIONS AND ADJUSTMENTS

64-18 ROCHESTER 4MV CARBURETOR CALIBRATIONS

NOTE: All carburetors have a color code paint mark and a part number stamped on the float bowl for identification.

	350 Eng. Man. Trans.	350 Eng. Auto. Trans.	455 Eng. Man. Trans.	455 Eng. Auto. Trans.	455 Eng. Stage I	455 Eng. Riviera
Paint Color	Red	Yellow	Dark Blue	Purple	Lt. Green	White
Model Designation	4MV	4MV	4MV	4MV	4MV	4MV
Number of Barrels	4	4	4	4	4	4
Carburetor Number	7040245	7040244	7040243	7040240	7040246	7040247
Code Letters						
Throttle Bore, Primary	1-3/8"	1-3/8"	1-3/8"	1-3/8"	1-3/8"	1-3/8"
Throttle Bore, Secondary	2-1/4"	2-1/4"	2-1/4"	2-1/4"	2-1/4"	2-1/4"
Small Venturi	9/32"	9/32"	9/32"	9/32"	9/32"	9/32"
Middle Venturi	5/8"	5/8"	5/8"	5/8"	5/8"	5/8"
Large Venturi	1-3/32"	1-3/32"	1-3/32"	1-3/32"	1-3/32"	1-3/32"
Main Metering Jet073"	.069"	.067"	.067"	.068"	.067"
Metering Rod, Primary						
Production043"	.045"	.041"	.041"	.042"	.041"
Altitude	Same	Same	Same	Same	Same	Same

NOTE: Special Kits Are Not Required for Altitude.

Metering Rod, Secondary	BS	BS	AY	AY	AU	AY
Idle Needle Hole	#44	#49	#44	#44	#44	#44
Spark Hole045" x .151"	.045" x .151"	.045" x .151"	.045" x .151"	.045" x .151"	.045" x .151"
Pump Discharge Hole	2-#70	2-#70	2-#70	2-#70	2-#70	2-#70
Fast Idle Cam Number	7040812	7040811	7040810	7040809	7040809	7040809

64-19 ROCHESTER 4MV CARBURETOR ADJUSTMENTS

	350 Eng. Man. Trans.	350 Eng. Auto. Trans.	455 Eng. Man. Trans.	455 Eng. Auto. Trans.	455 Eng. Stage I	455 Eng. Riviera
Choke Coil Rod Adjustment	Gaging Slot	Gaging Slot	Gaging Slot	Gaging Slot	Gaging Slot	Gaging Slot
Choke Hole Setting	Std. Hole	Std. Hole	Std. Hole	Std. Hole	Std. Hole	Std. Hole
Float Level	5/16"	5/16"	3/8"	3/8"	5/16"	3/8"
Pump Rod Location	Outer Hole	Outer Hole	Inner Hole	Inner Hole	Inner Hole	Inner Hole
Pump Adjustment	13/32"	13/32"	9/32"	9/32"	9/32"	9/32"
Choke Rod Adjustment	.130"	.130"	.130"	.130"	.130"	.130"
Vacuum Brake Adjustment (Primary)	.215"	.170"	.215"	.180"	.200"	.160"
Vacuum Break Adjustment (Secondary)	—	.150"	.195"	.160"	.180"	.160"
Air Valve Dash Pot Adjustment	.030"	.030"	.030"	.030"	.030"	.030"
Choke Unloader Adjustment	.335"	.335"	.335"	.335"	.335"	.325"
Air Valve Lockout Adjustment	—	.045"	—	—	—	—
Throttle Valve Lockout Adjustment	.015"	—	.015"	.015"	.015"	.015"
Secondary Opening Adjustment	.070"	.070"	Center of Slot	.070"	.070"	.070"
Secondary Closing	.020"	.020"	.020"	.020"	.020"	.020"
Secondary Metering Rod	53/64"	53/64"	53/64"	53/64"	53/64"	53/64"
Air Valve Spring Wind-Up	1/2 Turn	1/2 Turn	1/2 Turn	1/2 Turn	1/2 Turn	1/2 Turn
Fast Idle Speed (In Drive, Low Step)	720	650	720	650	650	650
Slow Idle Speed (In Drive)	700	600	700	600	600	600

64D-02

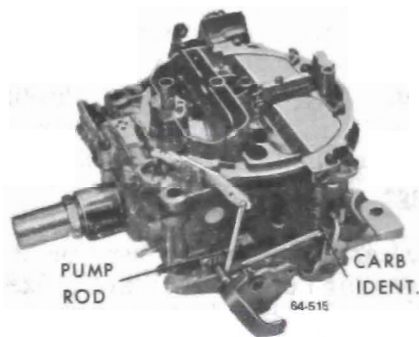

Figure 64-28 Rochester Quadrajets Carburetor

DIVISION II

DESCRIPTION AND OPERATION

64-20 DESCRIPTION AND OPERATION OF ROCHESTER QUADRAJET CARBURETOR

a. General Description

The Quadrajets carburetor has two stages in operation. The primary side has small bores with triple venturi equipped with plain tube nozzles. The triple venturi, plus the

smaller primary bores, give a finer fuel control in the idle and economy ranges of operation. Fuel metering in the primary side is accomplished with tapered metering rods positioned by a vacuum piston.

The secondary side has two very large bores which have ample air capacity to meet present day and future automotive engine demands. See Figure 64-29.

Using the air valve principle, fuel is metered in direct proportion to the air passing through the secondary bores. See Figure 64-30.

The small fuel reservoir is centrally located to avoid problems of fuel slosh causing engine turn cut-out and delayed fuel flow to the carburetor bores. The float system uses a single float pontoon. The float valve has a synthetic tip which gives added insurance against flooding problems caused by dirt.

A 2 inch pleated paper fuel filter is mounted in the fuel inlet casting and is easily removed for replacement.

The 1970 model carburetors have a dual vacuum break system for improved cold driveaway during choke operation.

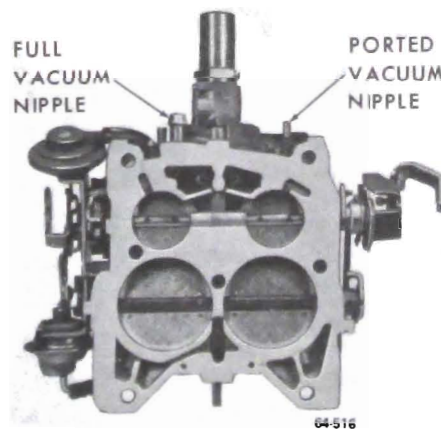

Figure 64-29 Quadrajets Carburetor - Bottom View

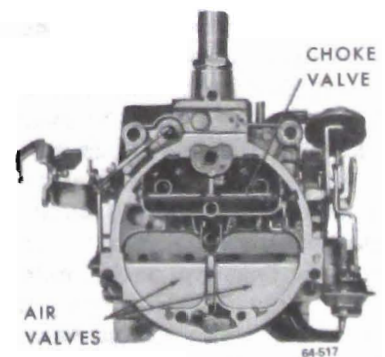

Figure 64-30 Quadrajets Carburetor - Top View

All external carburetor vents have been removed to prevent raw fuel vapors from being vented externally into the atmosphere. The carburetor is vented internally as in previous years to insure adequate fuel balance between the float chamber and air passing through the carburetor venturi.

The primary side of the carburetor has six systems of operation. They are float, idle, main metering, power, pump and choke.

The secondary side has one metering system which supplements the primary main metering system and receives fuel from a common float chamber.

b. Operation of Float System

The float system consists of a fuel chamber in the float bowl, single pontoon float, float hinge pin, and retainer combination, float needle valve and seat, and a float valve pull clip. A plastic filler block is located in the top of the float chamber over the float valve to prevent fuel slosh into this area.

The float system operates in the following manner: Fuel from the engine fuel pump enters the carburetor fuel inlet passage. It passes through the filter element, fuel inlet valve and on into the float chamber. As the incoming fuel fills the float bowl to the prescribed level, the float pontoon rises and forces the fuel inlet valve closed, shutting off fuel flow. As fuel is used from the float bowl the float drops, which opens the float needle valve, allowing more fuel to again fill the bowl. This cycle continues, maintaining a constant fuel level in the float bowl.

A float needle pull clip, fastened to the float needle valve, hooks over the edge of the float arm at the center as shown in Figure 64-31. Its purpose is to assist in lifting the float valve off its seat whenever fuel level in the float bowl is low.

The carburetor float chamber is

internally vented through two vent tubes located in the air horn. The internal vent tubes lead from beneath the air cleaner to the float bowl chamber. Their purpose is to balance air pressure acting on the fuel in the bowl with air flow through the carburetor bores. In this way, balanced air/fuel ratios can be maintained throughout all carburetor ranges of operation. The internal vent tubes also allow the escape of fuel vapors which may form in the float chamber during hot engine operation. This prevents fuel vaporization from causing excessive pressure build up in the float bowl, which can result in excessive fuel spillage into the carburetor bores.

c. Operation of Idle System

The Quadrajets carburetor has an idle system on the primary side of the carburetor only. Each primary bore has a separate and independent idle system consisting of an idle tube, idle passages, idle air bleeds, an idle channel restriction, an idle mixture adjustment needle, and an idle discharge hole. See Figure 64-32.

The idle system operates as follows:

Fuel is forced from the float bowl down through the primary metering jets into the main fuel well. It passes from the main fuel well into the idle passage where it is picked up by the idle tubes. The fuel is metered at the tip of the idle tubes and passes up through the idle tubes. The fuel is mixed with air at the top of each idle tube through an idle air bleed. The fuel mixture then crosses over to the idle down channels where it passes through a calibrated idle channel restriction.

It then passes down the idle channel past the lower idle air bleed holes and off-idle discharge ports, just above the primary throttle valves where it is mixed with more air. The air/fuel mixture then moves down to the idle needle discharge holes, where it enters the carburetor bores and mixes finally with air passing around the slightly open throttle valves. The idle needle hole size is fixed to limit richness in the idle range.

The carburetor models used on the larger engines for 1970 have a fixed

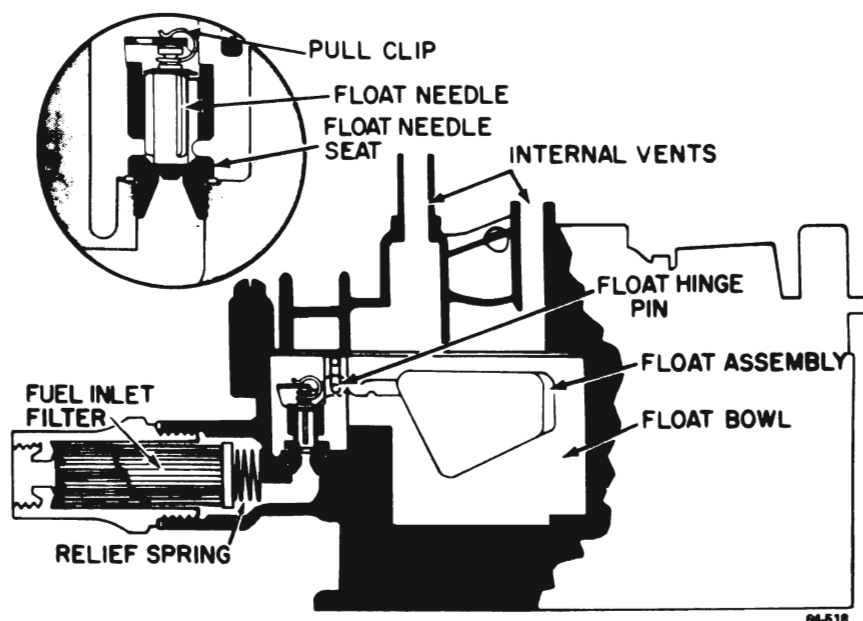

Figure 64-31 Float System

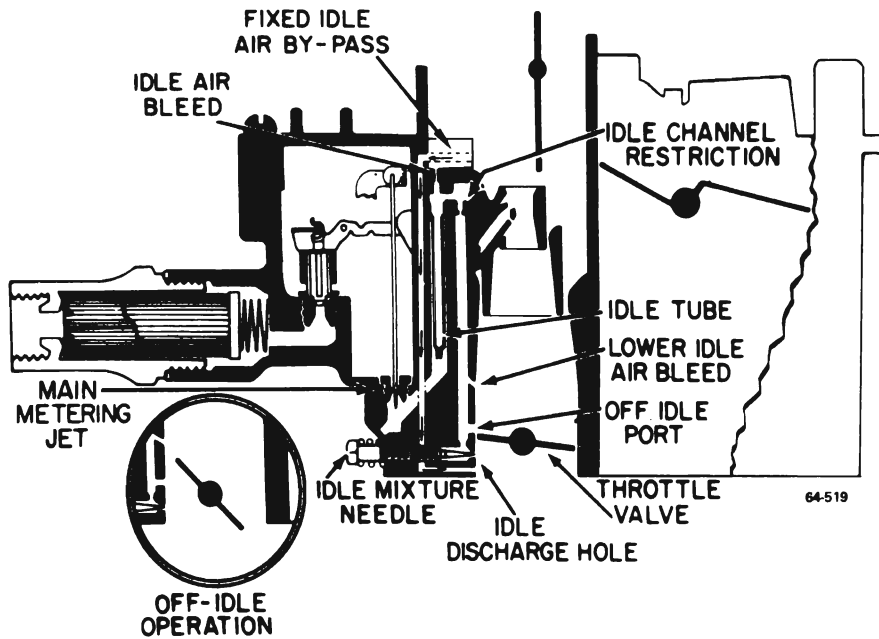

Figure 64-32 Idle System

idle air by-pass system. This consists of air channels which lead from the top of each carburetor bore in the air horn to a point below each primary throttle valve. At normal idle, extra air passes through these channels supplementing the air passing by the slightly opened throttle valves. The purpose of the idle air by-pass system is to allow reduction in the amount of air going past the throttle valves so that they can be nearly closed at idle. This reduces the amount of air flowing through the carburetor venturi to prevent the main fuel nozzles from feeding during idle operation. The venturi system is very sensitive to air flow and on these applications where larger amounts of idle air are needed to maintain idle speed, the fixed idle air by-pass system is used.

d. Off Idle Operation

As the primary throttle valves are opened from curb idle to increase engine speed, additional fuel is needed to combine with the extra air entering the engine. This is accomplished by the slotted off-idle discharge ports. As the primary throttle valves open, they pass by the off-idle

ports, gradually exposing them to high engine vacuum below the throttle valves. The additional fuel added from the off-idle ports mixes with the increasing air flow past the opening throttle valves to meet increased engine air and fuel demands.

Further opening of the throttle valves increases the air velocity through the carburetor venturi sufficiently to cause low pressure at the lower idle air bleeds. As a result, fuel begins to discharge from the lower idle air bleed holes and continues to do so throughout operation of the part throttle to wide open throttle ranges, supplementing the main discharge nozzle delivery. See Figure 64-32.

e. Operation of Main Metering System

The main metering system supplies fuel through the primary bores from off-idle to wide open throttle operation.

During cruising speeds and light engine loads, the high engine manifold vacuum holds the main metering rods down in the main metering

jets against spring tension. Fuel flow is then metered between the largest section of the metering rods and the main metering jets. See Figure 64-33.

Fuel flows from the float bowl through the main metering jets into the main fuel well and is mixed with air from the vent at the top of the main well and side bleeds (one of which leads from inside the bore area above the venturi and another from the cavity around the main fuel nozzle in the main well). The fuel then passes through the main discharge nozzle into the boost venturi and on into the engine.

A part throttle adjustment is made at the factory, then sealed; no attempt should be made to adjust it in the field. The adjustable part throttle feature includes a new power piston and primary metering rods. The new piston has a pin pressed into it, which protrudes through the float bowl and gasket and contacts the adjustable link in the throttle body. See Figure 64-33. The new primary metering rods have a different taper than the rods used before. These rods can be identified by the suffix "B" stamped after the diameter on the rod. The purpose of the adjustable part throttle feature is to give a finer metering control in the part throttle range for elimination of exhaust emissions. If the throttle body needs replacement in the field, there are specifications and adjustment procedures included in the throttle body kit.

f. Operation of Power System

The power system provides extra mixture enrichment for heavy acceleration or high speed operation. The richer mixture is supplied through the main metering system in the primary and secondary sides of the carburetor.

The power system located in the primary side consists of a vacuum piston and spring located in a cylinder connected by a passage to intake manifold vacuum. The spring

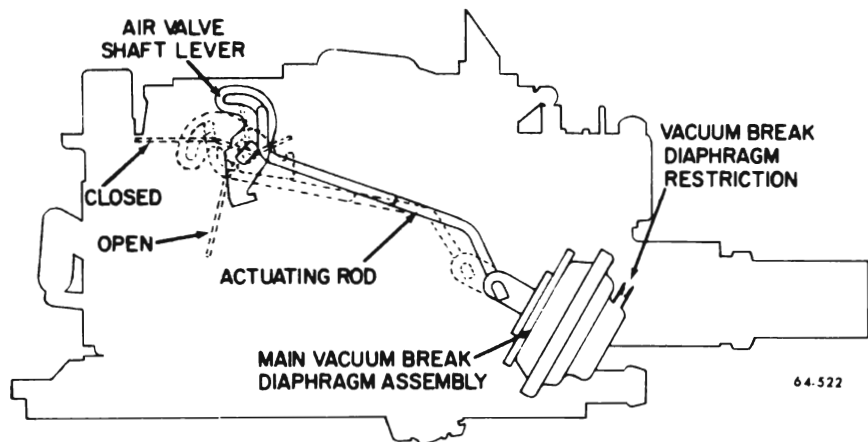

Figure 64-35 Air Valve Dash Pot Operation

degree which in turn lifts the secondary metering rods further out of the orifice discs. The metering rods are tapered so that fuel flow through the secondary metering orifice disc is directly proportional to air flow through the secondary carburetor bores.

There are three other features incorporated in the secondary metering system which are as follows:

1. The main well bleed tubes extend below the fuel level in the main well. These bleed air into the fuel in the well to quickly emulsify the fuel with air for good atomization as it leaves the secondary discharge nozzles.
2. The secondary metering rods have a slot milled in the side to insure adequate fuel supply in the secondary fuel wells. These are necessary because, when the air valve is in the closed position, the secondary metering rods are nearly seated against the secondary metering orifice discs. During hot engine idle or hot soak the fuel could boil away out of the fuel well. The milled slot allows enough fuel to by-pass the orifice disc to keep the main well filled during this period. This insures immediate fuel delivery from the secondary fuel wells at all times.
3. Two baffle plates are used, one in each secondary bore. They extend up and around the secondary fuel discharge nozzles. Their purpose is to provide good fuel distribution at lower air flows by preventing too much fuel from going to the front of the engine.

g. Operation of Air Valve Dash Pot

The air valve dashpot operates off of the main choke vacuum break diaphragm unit. The secondary air valve is connected to the choke vacuum break unit by a rod, to control the opening rate of the air valve. This delays the air valve opening rate to prevent secondary discharge nozzle "lag."

Whenever manifold vacuum is above approximately 5" to 6" Hg, the vacuum break diaphragm is seated (plunger is fully inward) against spring tension. At this point, the vacuum break rod is in the forward end of the slot in the air valve lever and the air valves are closed.

During acceleration or heavy engine loads, when the secondary throttle valves are open, the manifold vacuum drops. The spring located in the vacuum break diaphragm overcomes the vacuum pull and forces the plunger and link outward which, in turn, allows the air valves to open. The opening rate of the air valves is controlled by the calibrated restriction in the vacuum inlet nipple in the diaphragm cover. This gives the dashpot action required to delay air valve opening enough for efficient fuel flow from the secondary discharge nozzles.

h. Operation of Accelerating Pump System

During quick acceleration, when the throttle is opened rapidly, the air flow changes almost instantaneously.

The fuel, which is heavier, tends to lag behind causing a momentary leanness. The accelerator pump is used to provide the extra fuel necessary for smooth operation during this time.

When the pump plunger moves upward in the pump well, fuel from the float bowl enters the pump well through a slot in the top of the pump well. It flows past the synthetic pump cup seal into the bottom of the pump well. The pump plunger is a floating type. (The cup moves up and down on the pump plunger head). When the pump plunger is moved upward the flat on the top of the cup unseats from the flat on the plunger head and allows free movement of fuel through the inside of the cup into the bottom of the pump well. This also vents any vapors which may be in the bottom of the pump well so that a solid charge of fuel can be maintained in the fuel well beneath the plunger head. When the primary throttle valves are opened the connecting linkage forces the pump plunger downward. The pump cup seats instantly and fuel is forced through the pump discharge passage, where it unseats the pump discharge check ball and passes on through the passage to the pump jets located in the air horn. See Figure 64-36.

It should be noted the pump plunger is spring loaded. The top pump duration spring is balanced with the bottom pump return spring so that a smooth sustained charge of fuel is delivered during acceleration.

The pump discharge check ball seats in the pump discharge passage during upward motion of the pump plunger so that air will not be drawn into the passage; otherwise, a momentary acceleration lag could result.

During high speed operation, a vacuum exists at the pump jets. A cavity just beyond the pump jets is vented to the top of the air horn, outside the carburetor bores. This acts as a suction breaker so that

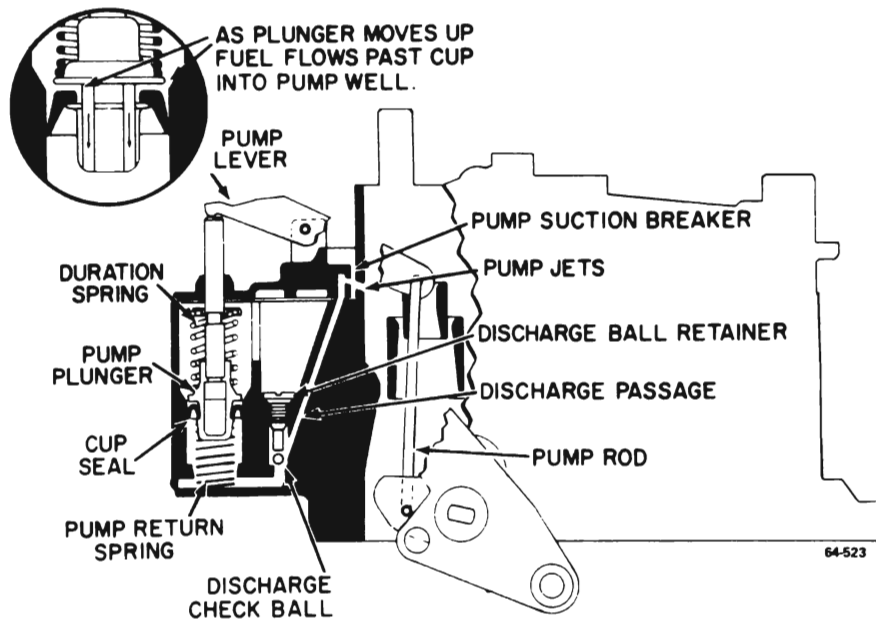

ACCELERATING PUMP SYSTEM

Figure 64-36 - Accelerator Pump System

when the pump is not in operation fuel will not be pulled out of the pump jets into the venturi area. This insures a full pump stream when needed and prevents any fuel "pull over" from the pump discharge passage.

the thermostatic coil. This restricts air flow through the carburetor to provide a richer starting mixture. When the engine starts and is running, manifold vacuum is applied to the vacuum diaphragm units

mounted on the side of the float bowl. The front or primary vacuum break diaphragm will open the choke valve to a point where the engine will run without loading or stalling. As the engine manifold is wetted and friction decreases after the start, the secondary or (rear) vacuum break unit, which has a delayed action, gradually opens the choke valve a little further to prevent loading.

The primary vacuum break unit is standard and operates the same as on previous units. The secondary (rear) vacuum break unit is delayed in operation by an internal bleed. This delays further opening of the choke valve a few seconds until the engine will run at a slightly leaner mixture.

Included in the secondary vacuum break unit is a spring loaded plunger. The purpose of the spring is to offset choke thermostatic coil tension and balance the greater opening of the choke valve with tension of the choke coil. This enables further refinement because the coil, which senses engine temperature, will allow the choke valve to

i. Operation of Choke System

The Quadrajets choke valve is located in the primary side of the carburetor. It provides the correct air/fuel mixture enrichment to the engine for quick cold engine starting and during the warm-up period. The air valve is locked closed until the choke valve is wide open.

The thermostatic coil located in the engine manifold is calibrated to hold the choke valve closed when the engine is cold. See Figure 64-37.

When the choke valve is closed, the air valve lock-out lever is weighted so that a tang on the lever catches the upper edge of the air valve and keeps the air valve closed.

During engine cranking, the choke valve is held closed by the tension of

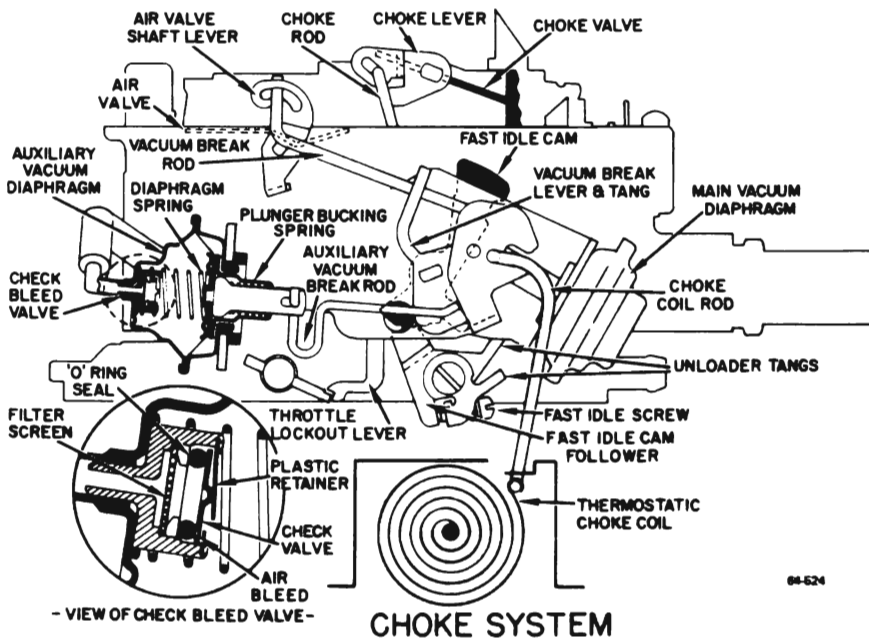

Figure 64-37 - Choke System

open gradually against spring tension in the diaphragm plunger head.

After the vacuum break diaphragm units open the choke valve and the accelerator is depressed, the fast idle cam follower lever on the end of the primary throttle shaft will drop from the highest step on the fast idle cam to a lower step. This gives the engine the correct fast idle and fuel mixture for running until the engine begins to warm up and heat the thermostatic coil. As the thermostatic coil on the engine manifold becomes heated, it relaxes its tension and allows the choke valve to open further because of intake air pushing on the offset choke valve. The choke valve opening continues until the thermostatic coil is completely relaxed at which point the choke valve is wide open.

When the engine is thoroughly warm, the choke coil pulls the vacuum break lever completely down and allows the fast idle cam to rotate so that the cam follower steps drop off the last step of the fast idle cam allowing the engine to run at normal idle speed. When the choke valve is completely open, a lever on the end of the choke shaft pushes upward on the air valve lockout lever and unlocks the air valves.

The choke system is equipped with an unloader mechanism which is designed to partially open the choke valve, should the engine become loaded or flooded. To unload the engine the accelerator pedal must be depressed so that the throttle valves are held wide open. A tang on a lever on the choke side of the primary throttle shaft contacts the fast idle cam and, through the intermediate choke shaft, forces the choke valve slightly open. This allows extra air to enter the carburetor bores to lean out the fuel mixture so that the engine will start.

DIVISION III

SERVICE PROCEDURES

64-2I DISASSEMBLY, CLEANING AND INSPECTION OF ROCHESTER QUADRAJET CARBURETOR

NOTE: *Place carburetor on proper holding fixture.*

a. Air Horn Removal

1. Remove clip from upper end of choke rod, disconnect choke rod from upper choke shaft lever, and remove the choke rod from lower lever in bowl cavity.

2. To disconnect pump rod, drive small roll pin (pump lever pivot pin) inward, using a small drift, until pump lever can be removed from air horn. Then remove pump lever from pump rod.

3. Remove secondary metering rods from secondary wells by removing small screw in the secondary metering rod holder. Lift rods and holder as an assembly from carburetor.

NOTE: *The vacuum break diaphragm rod is clipless, so it will be necessary to remove during air horn removal.*

4. Remove nine air horn to bowl attaching screws, two of which are located next to the primary venturi; (two long screws, five short screws, and two countersunk screws).

5. Remove air horn by lifting straight up. After air horn is clear of float bowl, rotate air horn to remove vacuum break diaphragm rod from dashpot lever on the end of the air valve shaft. Air horn gasket should remain on bowl for removal later.

CAUTION: *Care must be taken not to bend the small tubes protruding from the air horn. These are permanently pressed into the casting. Do not remove.*

b. Air Horn Disassembly

NOTE: *Further disassembly of the air horn is not required for cleaning purposes. If part replacement is required, proceed as follows:*

1. Remove choke valve attaching screws, then remove choke valve and shaft. Caution: Air valves and air valve shaft are calibrated and should not be removed.

c. Float Bowl Disassembly

1. Remove pump plunger from pump well.

2. Remove air horn gasket from dowels on secondary side of bowl, then remove gasket from around power piston and primary metering rods.

3. Remove pump return spring from pump well.

4. Remove plastic filler over float valve.

5. Remove power piston and primary metering rods, using needle-nose pliers to pull straight up on metering rod hanger directly over power piston. Remove power piston spring from well.

6. Remove metering rods from power piston by disconnecting tension springs from top of each rod; then rotate rod to remove from hanger.

7. Remove float and needle assembly by lifting up on retaining pin.

8. Remove float needle and pull clip assembly from float arm.

9. Remove needle seat and gasket.

10. Remove primary metering jets. No attempt should be made to remove secondary metering plates.

11. Remove pump discharge check ball retainer and check ball.

12. Remove baffle from secondary side of float bowl.

13. Remove vacuum break hoses from primary vacuum break assembly and secondary vacuum break assembly.

14. Remove retaining screw from

choke bracket assembly and remove complete assembly from float bowl. Vacuum break rod can now be removed from the primary break diaphragm plunger by rotating rod out of plunger stem.

NOTE: *If further disassembly of the choke is necessary, spread the retaining ears on bracket for removing either the primary vacuum break diaphragm assembly or the secondary vacuum break assembly. The secondary vacuum break assembly has a rod connecting the plunger to the intermediate choke shaft lever. This can also be removed by rotating the vacuum break diaphragm assembly and sliding rod out of plunger stem and the other end out of vacuum break lever.*

CAUTION: *Do not place vacuum break assemblies in carburetor cleaner.*

15. Remove the fast idle cam from bushing on choke bracket assembly.

16. Remove lower choke rod actuating lever from inside of float bowl well.

17. Remove fuel inlet filter nut gasket, filter, and spring.

18. Remove throttle body by removing throttle body to bowl attaching screws.

19. Remove throttle body to bowl insulator gasket.

d. Throttle Body Disassembly

1. Remove pump rod from throttle lever by rotating rod out of primary throttle lever.

2. Remove idle mixture screws and springs.

CAUTION: *Extreme care must be taken to avoid damaging secondary throttle valves.*

NOTE: *No further disassembly of the throttle body is required.*

e. Cleaning and Inspection

NOTE: *The carburetor should be cleaned in a cold immersion type cleaner.*

1. Thoroughly clean carburetor castings and metal parts in an approved carburetor cleaner.

CAUTION: *Rubber parts, plastic parts, diaphragms, pump plungers, should not be immersed in carburetor cleaner. However, the delrin cam on the air valve shaft will withstand normal cleaning in carburetor cleaner.*

2. Blow out all passages in castings with compressed air. Do not pass drills through jets or passages.

3. Inspect idle mixture needles for damage.

4. Examine float needle and seat for wear. Replace if necessary with float needle assembly.

5. Inspect upper and lower surfaces of carburetor castings for damage.

6. Inspect holes in levers for excessive wear or out of round conditions. If worn, levers should be replaced.

7. Examine fast idle cam for wear or damage.

8. Check air valve for binding conditions. If air valve is damaged, air horn assembly must be replaced.

9. Check all throttle levers and valves for binds or other damage.

64-22 ASSEMBLY AND INTERNAL ADJUSTMENT OF ROCHESTER QUADRAJET CARBURETOR

a. Throttle Body Assembly

1. Install idle mixture needles and springs until seated. Back out needles two turns as a preliminary idle adjustment.

2. Install pump rod in hole of throttle lever by rotating rod.

b. Float Bowl Assembly

1. Install new throttle body to bowl insulator gasket being certain the gasket is properly installed over two locating dowels on bowl.

2. Install throttle body making certain throttle body is properly located over dowels on float bowl then install throttle body to bowl screws and tighten evenly and securely.

3. Place carburetor on proper holding fixture.

4. Install fuel inlet filter spring, filter, new gasket and inlet nut. Tighten nut securely.

NOTE: *If the vacuum break diaphragm assemblies were removed from choke bracket, slide assemblies between retaining ears and bend ears slightly together to hold securely. The secondary vacuum diaphragm rod must be installed in the vacuum break lever and plunger stem previous to installing the unit on the choke bracket.*

5. Install fast idle cam on vacuum break assembly. Be sure fast idle cam actuating tang on intermediate choke shaft lever, (vacuum break lever) is located in cut out area of fast idle cam.

6. Connect choke rod to choke rod actuating lever (plain end) then holding choke rod, with grooved end pointing inward, position choke rod actuating lever in well of float bowl and install choke assembly, engaging intermediate choke shaft with hole in actuating lever. Install retaining screw and tighten securely. Remove choke rod from lever for installation later.

NOTE: *Lower choke lever holding tool J-6911 can be used for holding lever in place while installing choke bracket assembly.*

7. Install both vacuum break diaphragm hoses. The shorter vacuum hose goes to the primary or front vacuum break diaphragm unit.

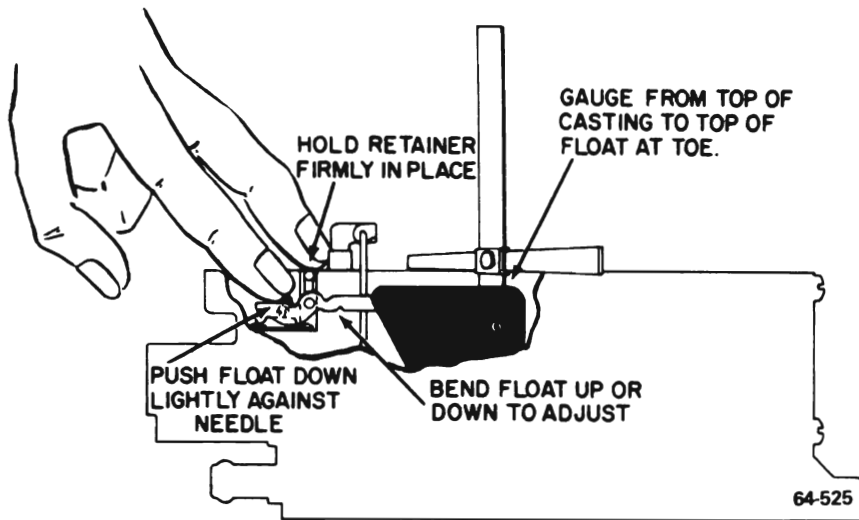

Figure 64-38 - Float Level Adjustment

8. Install air deflector in secondary side of bowl with notches towards top.

9. Install pump discharge check ball and retainer in passage next to pump well. Tighten securely.

10. Install primary main metering jets. Tighten securely.

11. Install float needle seat and gasket. Tighten securely.

12. Install pull clip on needle. Install needle and pull clip on float.

NOTE: *The float needle pull clip hooks over the edge of the float arm and not through the locating holes in the center.*

13. Install float, needle and retaining pin assembly in float bowl.

14. *Float level adjustment.*

a. With adjustable T-scale measure from top of float bowl gasket surface (gasket removed) to top of float at toe (locate gaging point 1/16" back from radius at toe). See Figure 64-38.

NOTE: *Make sure retaining pin is held firmly in place and tang of float is seated on float needle. See specifications in paragraph 64-19.*

b. Bend float up or down for proper adjustment.

15. Install power piston spring in power piston well. If primary main metering rods were removed from hanger re-install making sure that tension spring is connected to top of each metering rod. Install power piston assembly in well with metering rods properly positioned in metering jets. Press down firmly on power piston to make sure the retainer is properly positioned in the bore.

16. Install plastic filler over float needle, pressing downward until seated properly.

17. Install pump return spring in pump well.

18. Install air horn gasket around primary metering rods and piston. Position gasket over two dowels on secondary side of bowl.

19. Install pump plunger in pump well.

c. Air Horn Assembly

1. Install the following if removed:

Choke shaft, choke valve, and two attaching screws.

2. Normally, the air valve and shaft do not have to be removed from the air horn for cleaning purposes. A repair kit is available which includes a new plastic cam, an air valve torsion spring, retaining pin. Complete instructions are included in the kit for installation.

d. Air Horn to Bowl Installation

1. Place air horn assembly on bowl carefully, positioning vent tubes and accelerating well tubes over air horn gasket. Install vacuum break rod into main vacuum break diaphragm plunger and into slotted air valve lever on air horn before the air horn is lowered onto float bowl. Carefully lower air horn assembly over pump plunger stem and locating dowels until properly seated.

2. Install two long air horn screws, five short screws, and two counter-sunk screws in primary venturi area. All screws must be tightened evenly and securely. See Figure 64-48 for proper tightening sequence.

3. Install two secondary metering rods into the secondary metering rod hanger (upper ends of rod point towards each other). Install secondary metering rod holder onto air valve cam follower. Install retaining screw and tighten securely. Work air valves up and down several times to make sure they are free in all positions.

4. Connect pump lever to upper end of pump rod. Place pump lever on air horn casting. Align hole in pump casting and push pump roll pin back through casting until end of pin is flush with casting.

5. Connect choke rod in lower choke lever and retain in upper lever with clip.

64-23 EXTERNAL ADJUSTMENT OF ROCHESTER QUADRAJET CARBURETOR

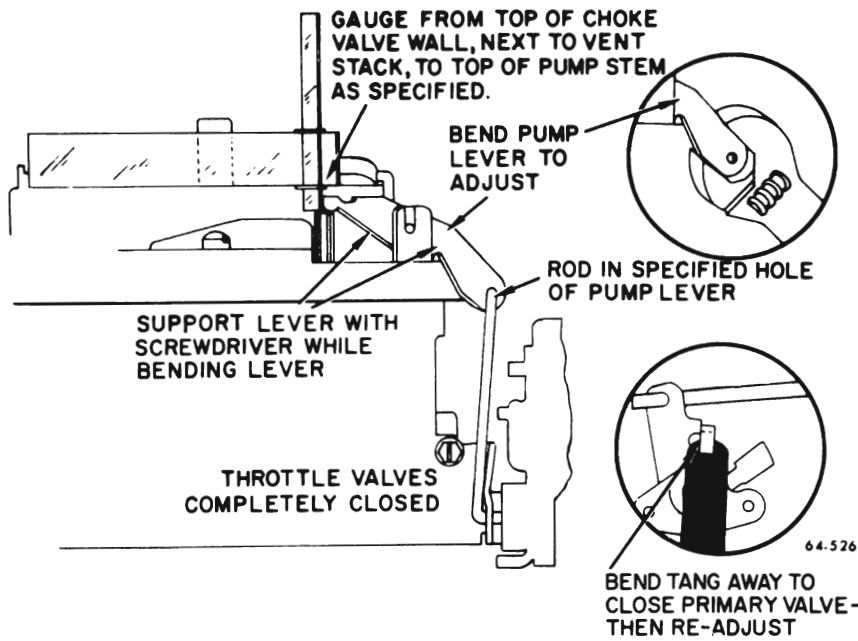

Figure 64-39 - Accelerator Pump Adjustment

a. Accelerator Pump Adjustment

Completely close primary throttle valves by backing out slow idle screw and making sure fast idle cam follower is off steps of fast idle cam (choke valve wide open). It will also be necessary to bend the secondary throttle closing tang away from primary throttle lever, to obtain closed throttle valves. See inset Figure 64-39.

With pump rod in specified hole in pump lever, gauge from top of choke valve wall next to vent stack, to top of pump stem.

To adjust, bend pump lever, as shown, with adjustable wrench, and also supporting pump lever between lever and top of air horn with tip of screwdriver.

After adjustment is made, readjust secondary throttle closing tang and slow idle screw.

b. Fast Idle Adjustment

With engine warm, transmission in drive and cam follower on low step of fast idle cam, adjust fast idle screw

so that engine runs 620 RPM (auto. Transmission) or 720 RPM (manual transmission). See Figure 64-40.

c. Choke Rod Adjustment

Place the fast idle cam follower on the second step of the fast idle cam

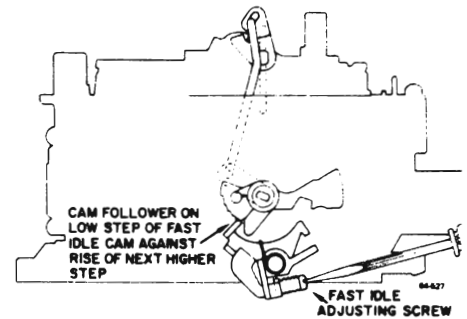

Figure 64-40 Fast Idle Adjustment

and hold it against the high step by pushing lightly upward on the vacuum break lever. With the choke rod in the bottom of the slot in the choke lever, measure the dimensions between the lower edge of the choke valve at choke lever end, and air horn wall. The dimension should be as specified.

If adjustment is necessary, bend the choke rod at the point shown. See Figure 64-41.

d. Primary Vacuum Break Adjustment

Seat vacuum break diaphragm using Special Tool J-23417, Vacuum Break Actuator.

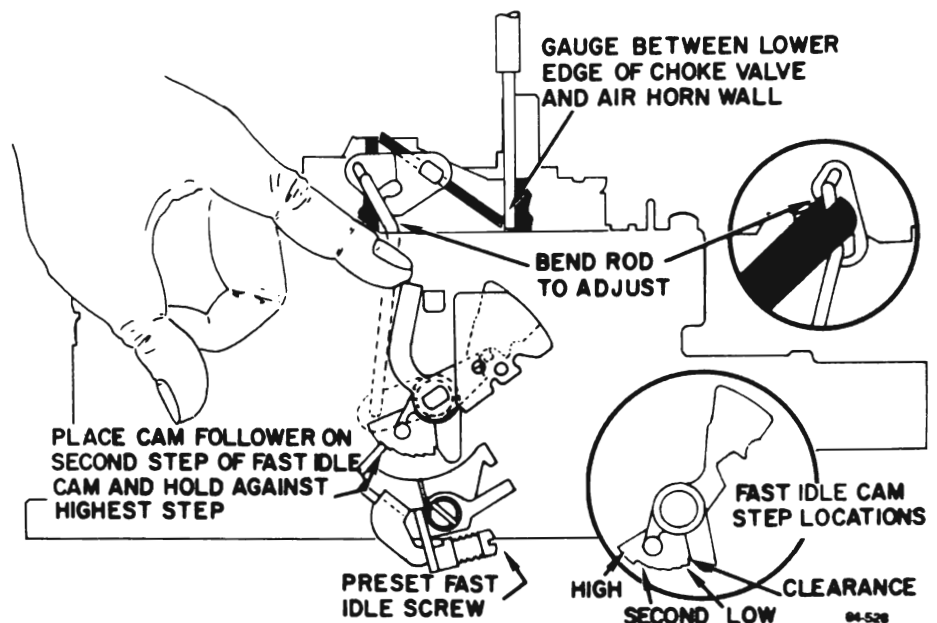

Figure 64-41 - Choke Rod Adjustment

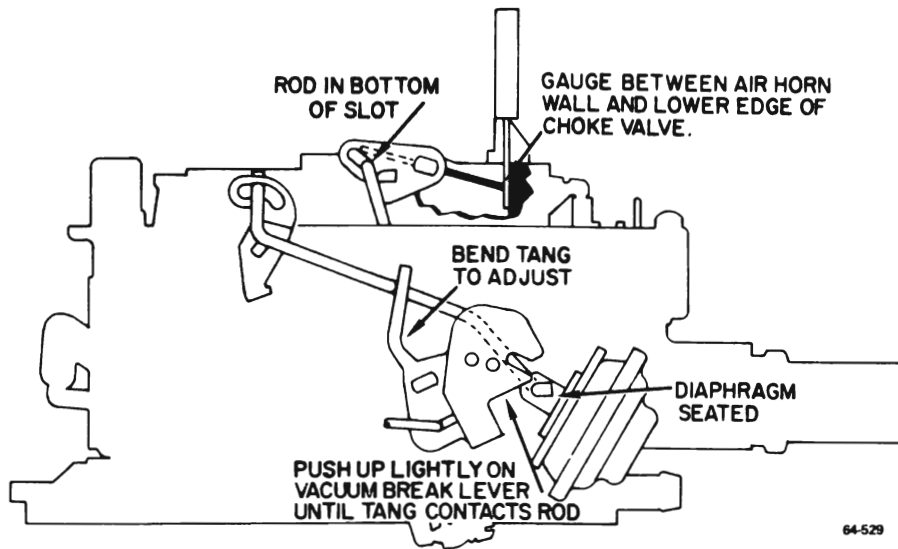

Figure 64-42 - Primary Vacuum Break Adjustment

With vacuum break diaphragm seated and with vacuum break lever tang held lightly against the vacuum break rod, measure the dimension between the lower edge of choke valve and air horn, as shown.

Bend vacuum break tang on lever to adjust. See Figure 64-42.

e. Secondary Vacuum Break Adjustment

Fully seat the auxiliary vacuum break diaphragm plunger using an outside vacuum source. With the secondary vacuum break diaphragm in the fully seated position, rotate the choke valve towards the closed choke position, pushing on the vacuum break lever until the spring loaded diaphragm plunger is fully extended. With the choke valve held in this position, measure the distance between the lower edge of choke valve and inside air horn wall. Dimensions should be as specified; if not, bend the vacuum break link at the point shown to adjust. See Figure 64-43.

CAUTION: Care should be used when compressing the diaphragm plunger spring so that the force used in closing the choke valve does not pull the vacuum diaphragm off its seat.

f. Air Valve Dash Pot Adjustment

With the vacuum break diaphragm seated, there must be .030 inch clearance between the dash pot rod and end of slot in air valve lever.

Bend rod, at air valve end, to adjust. See Figure 64-44.

g. Choke Unloader Adjustment

Push up lightly on vacuum break lever, then open the primary throttle to the wide open position. With the

valves in this position, the dimension between the lower edge of choke valve and air horn wall should be .325 inch.

Bend the tang on the fast idle lever to adjust. See Figure 64-45.

h. Air Valve Lockout Adjustment (350 cu. in. automatic transmission only)

With choke valve wide open, apply sufficient force to thermostatic coil lever to move choke rod to top of slot in choke lever. Move air valve in direction to open valve.

Bend upper end of air valve lockout lever, if necessary, to give a specified opening between lockout tang and front edge of air valve. See Figure 64-46.

i. Choke Coil Rod Adjustment

Hold choke valve fully closed by rotating vacuum break lever counter-clockwise, as shown. Pull upward on choke thermostatic coil rod to end of travel. Rod should fit freely in gaging notch at edge of lever. Bend rod at loop as required to make it fit gaging notch.

Connect the thermostatic coil rod to the specified hole in lever. See Figure 64-47.

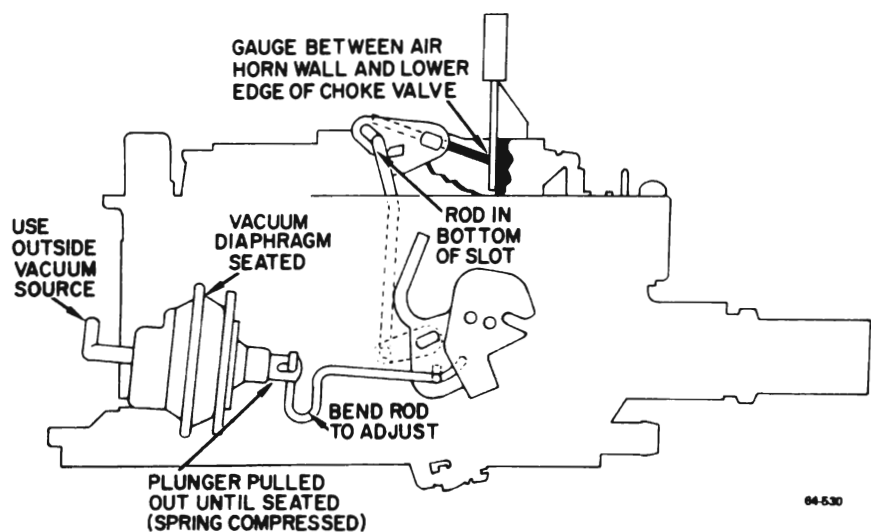

Figure 64-43 - Secondary Vacuum Break Adjustment

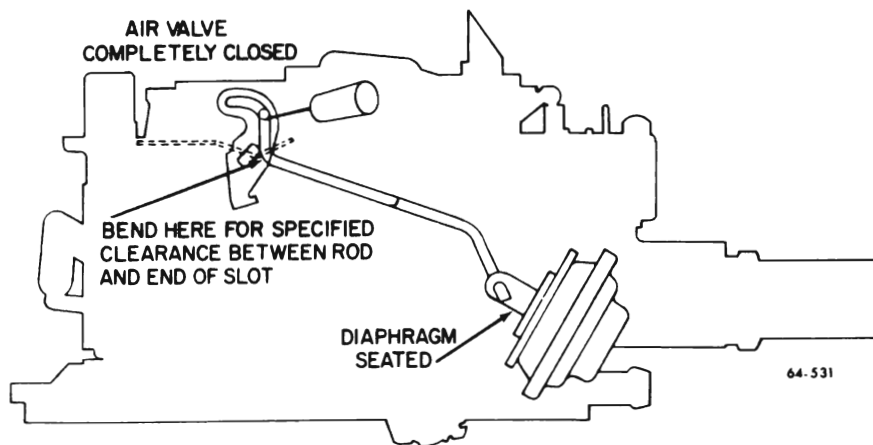

Figure 64-44 Air Valve Dash Pot Adjustment

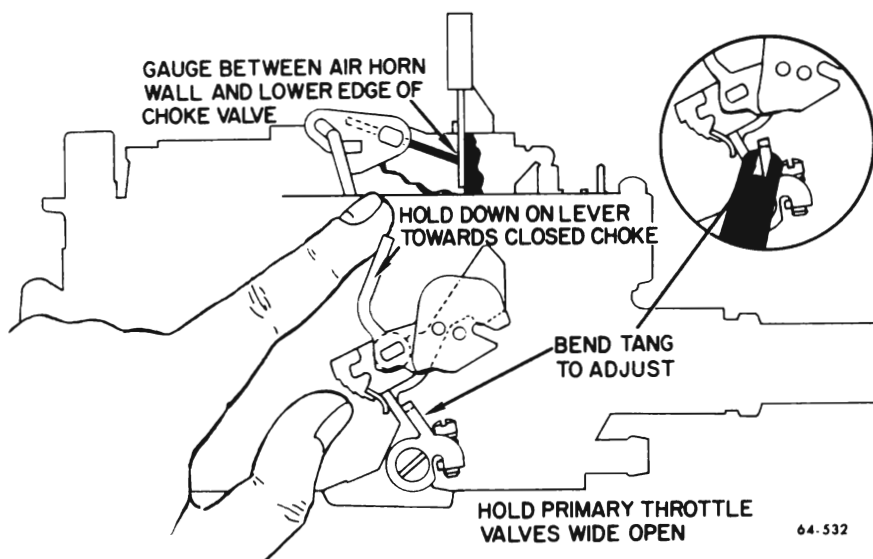
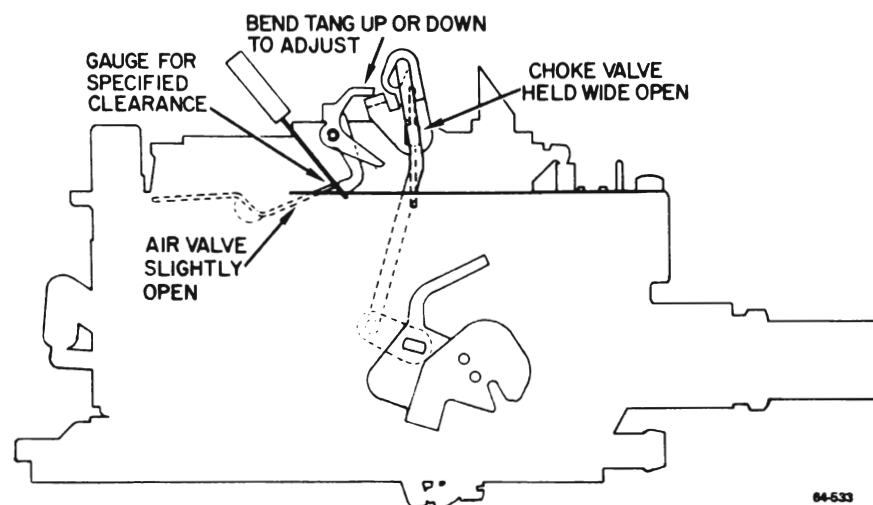

Figure 64-45 Choke Unloader Adjustment



AIR VALVE LOCKOUT ADJUSTMENT

Figure 64-46 Air Valve Lockout Adjustment

j. Air Horn Screw Tightening Sequence

To prevent binding of the choke valve or air valve due to distortion of the air horn, the air horn screws must be tightened in the proper sequence. Figure 64-48 show the proper tightening sequence. s

k. Secondary Closing Adjustment

To insure proper closing of the secondary throttle valves, check the closing adjustment as follows:

1. Set slow idle (curb idle) to recommended engine RPM, making sure cam follower is not resting on the steps of the fast idle cam (choke valve wide open).
2. There should be .020" clearance between secondary throttle actuating rod and front of slot in secondary throttle lever with closing tang on throttle lever resting against actuating lever.
3. Bend tang on primary throttle actuating lever to adjust. See Figure 64-49.

l. Secondary Opening Adjustment

For correct opening of the secondary throttle valves, the following adjustment should be checked:

1. Open primary throttle valves until actuating link contacts upper tang on secondary lever. When valve s are in this position:
 - (a) *With 2 point pick-up linkage*, bottom of link should be in center of secondary lever slot. See lower part of Figure 64-50.
 - (b) *With 3 point pick-up linkage*, clearance between link and middle tang should be .070 inch. See upper part of Figure 64-50.

2. Bend upper tang on secondary lever as required to adjust.

m. Secondary Metering Rod Adjustment

1. Check secondary metering rod adjustment by measuring from top of each metering rod to top of air horn casting next to air cleaner stud hole. Measurement should be $53/64$ in. See Figure 64-51.

2. Adjust, if necessary, by bending metering rod hanger at point shown in Figure 64-51. Make sure *both* rods are correctly adjusted.

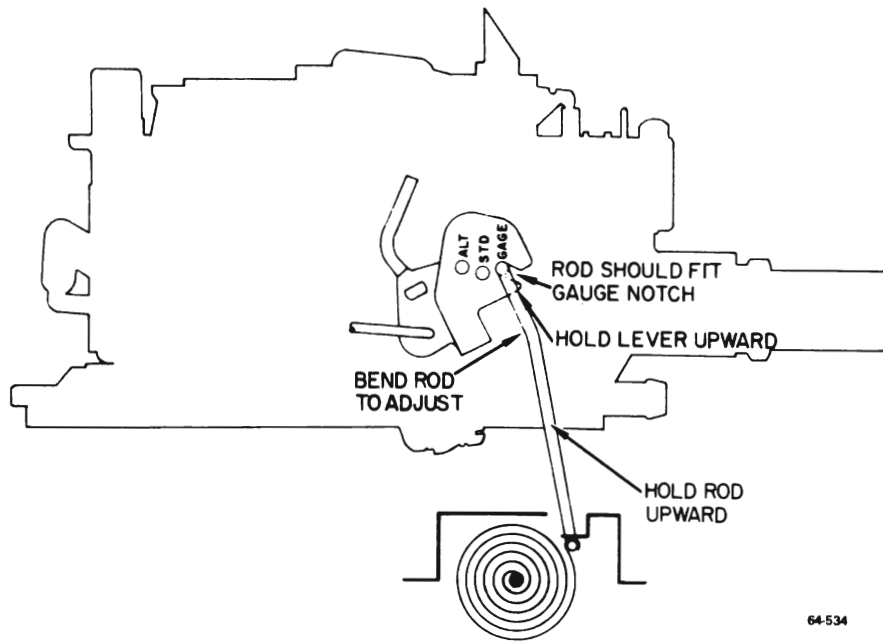

Figure 64-47 Choke Coil Rod Adjustment

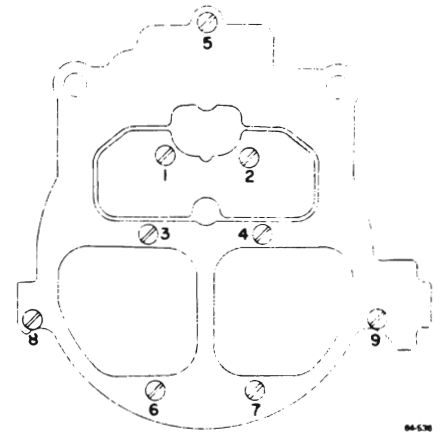
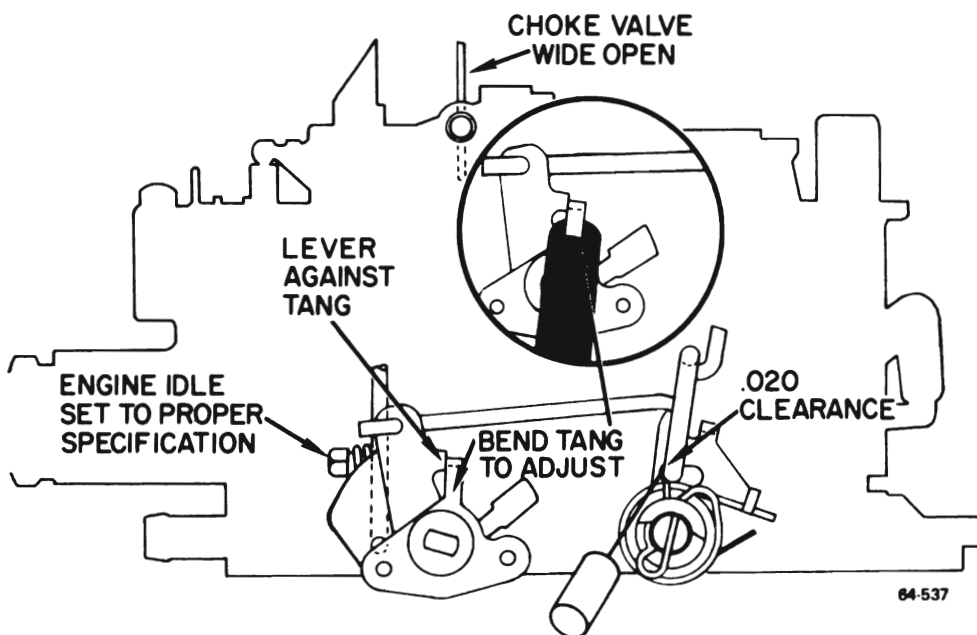

Figure 64-48 - Air Horn Screw Tightening Sequence



SECONDARY CLOSING ADJUSTMENT

Figure 64-49 - Secondary Closing Adjustment

n. Air Valve Spring Wind-Up Adjustment

To adjust air valve spring wind-up, loosen lock screw (Allen screw) and turn adjusting screw counterclockwise to remove all spring tension. With air valve held closed, turn adjusting screw clockwise until torsion spring just contacts pin in shaft; then turn adjusting screw clockwise exactly $1/2$ turn. While holding adjusting screw in this position, tighten lock screw. See Figure 64-52.

p. Secondary Throttle Valve Lockout Adjustment

NOTE: The secondary throttle valve lockout is used on all units except the small engine, automatic transmission model. This uses an air valve lockout in its place.

To adjust the secondary throttle valve lockout, proceed as follows:

1. *Opening Clearance* - Hold choke valve wide open by rotating vacuum break lever toward open choke (clockwise). With secondary throttle valves held partially open, measure the clearance between the end of the lockout pin and toe of lockout lever, as shown. Bend lockout lever at point shown to adjust.

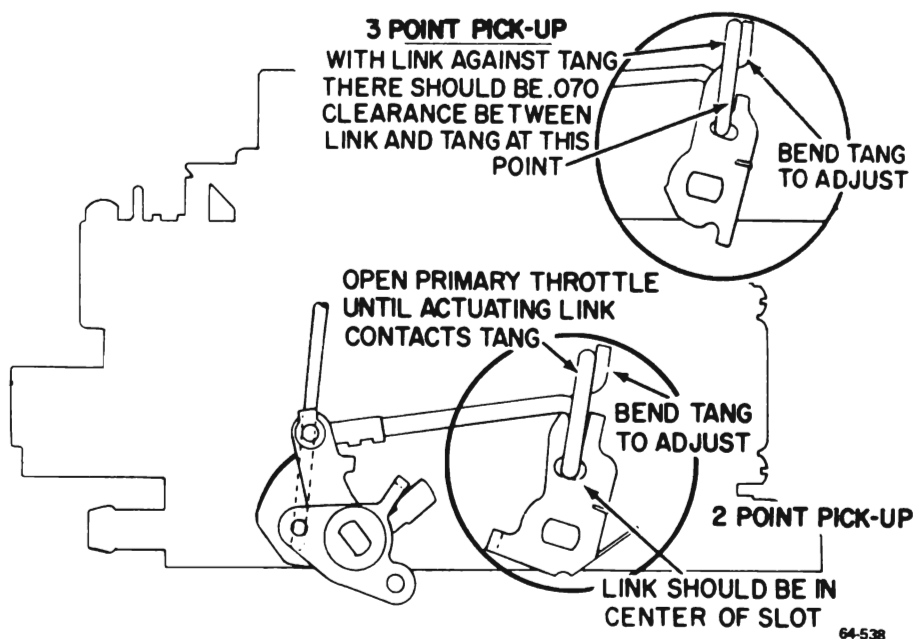

Figure 64-50 - Secondary Opening Adjustment

2. *Secondary Lockout Pin Side Clearance* - With choke valve and secondary throttle valve fully closed, bend lockout pin at point shown to maintain specified side clearance between side of lockout pin and lockout lever. See Figure 64-52A.

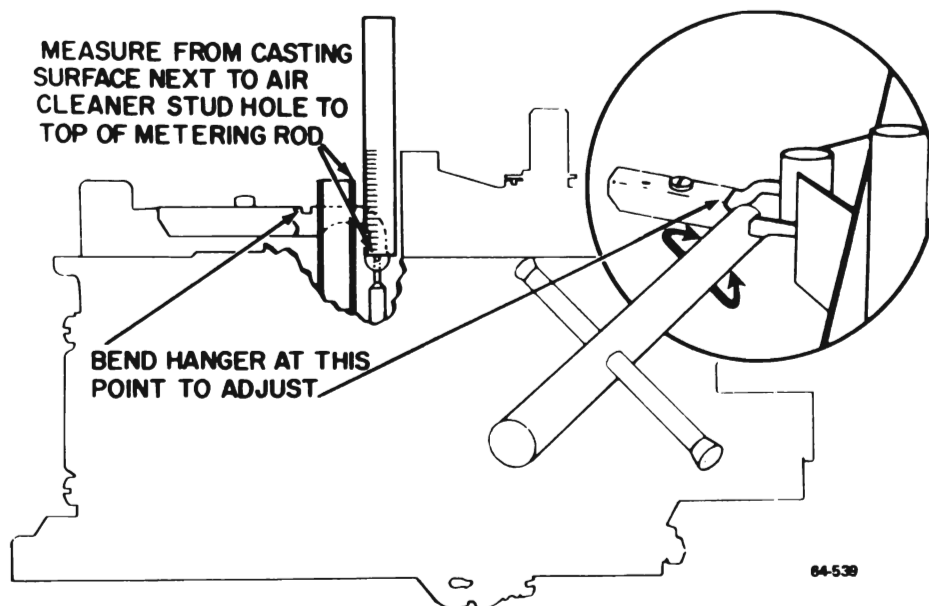

Figure 64-51 - Secondary Metering Rod Adjustment

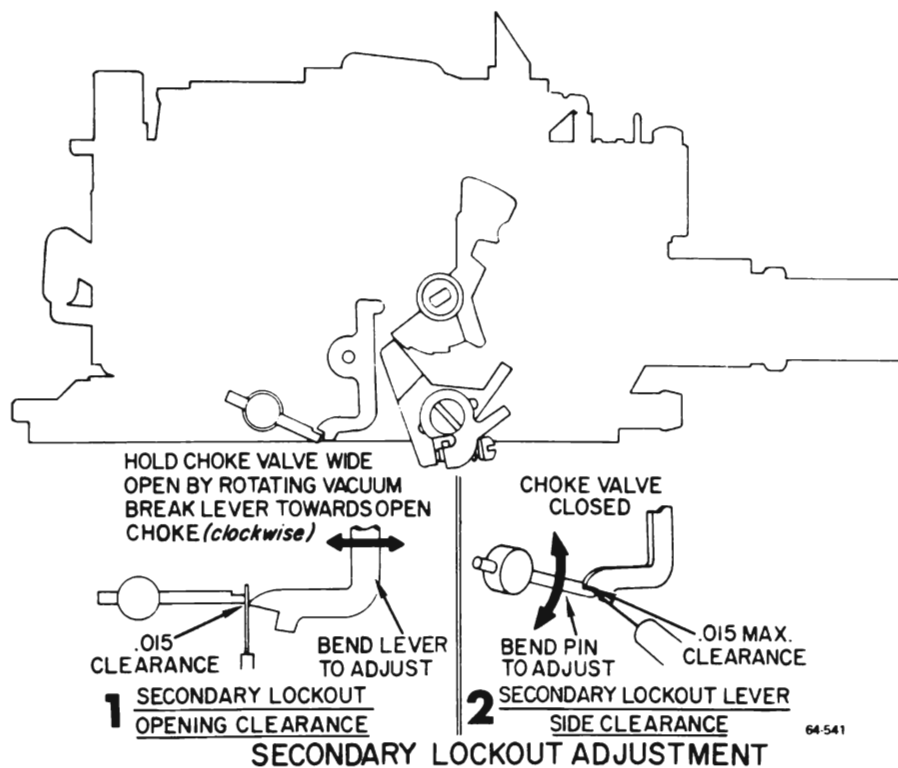

Figure 64-52 - Air Valve Spring Wind-Up Adjustment

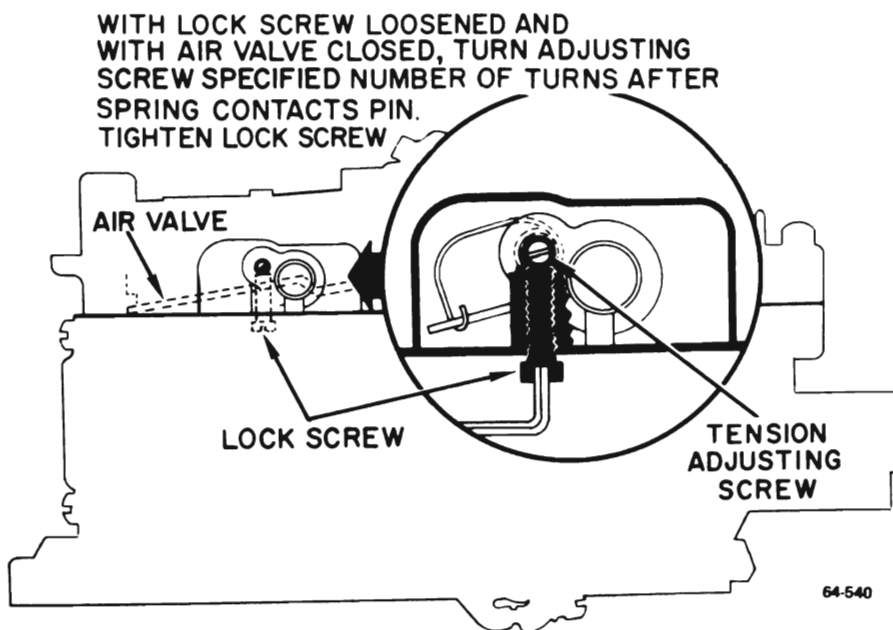

Figure 64-52A - Secondary Lockout Adjustment

MODEL 4 MV DIAGNOSIS CHART

CONDITION										CHECK POINTS
HARD STARTING—COLD	HARD STARTING—HOT	POOR OPERATION—DURING WARM UP	STUMBLE ON ACCELERATION	STALLING	ROUGH IDLE	ECONOMY	FLOODING	SURGE	LACK OF HIGH SPEED PERFORMANCE	
1	1					1				IMPORTANT
*		4				*				Before attempting carburetor diagnosis as outlined below, all other engine systems must be operating properly. Diagnosis of these systems (electrical, exhaust, mechanical, and in the case of fuel economy, odometer accuracy) is found in this Service Manual. The numbers 1, 2 and 3, under the CONDITION are the order of probability. The * indicates additional possibilities.
*		*				*				Driver Habits (Instruct Owner on Proper Procedures)
*		*				*				Check Choke Rod Adjustment
*										Check Vacuum Break Adjustments
										Check Choke Coil Rod Adjustment
										Check Choke Unloader Adjustment
2		1				2				Check Choke Valve & Linkage, Binding, Stuck or Gummed Up
			3						3	Air Valve Binding, Stuck, Wrong Spring Tension Adjustment
			*						*	Check Air Valve Lock-Out Adjustment (350 only)
			*						*	Secondary Metering Rods Bent, Wrong Part
			*						*	Secondary Baffle Plates Missing
			*						*	Secondary Main Discharge Nozzles Plugged or Dirty
			*			3		3	*	Power Piston Stuck or Binding
			*			*		*		No Vacuum to Power Piston
			*			4		*	*	Primary Metering Rods Altered, Bent or Wrong Part
*		*	1							Check Accelerator Pump System & Adjustment
				3						Throttle Return Check Misadjusted
									2	Fuel Pump Pressure or Vacuum Not to Specification
			*	1	1	*				Check Slow Idle Adjustment
		2		*		*				Check Fast Idle Adjustment
						*		1	*	Primary Metering Jets Loose or Wrong Part
	*		*		*	*	2	4	*	Float Sticking or Level Misadjusted
*	*				*	*	3	*		Float Bowl Porous, Cracked, Etc.
*					*				*	Throttle Body to Float Bowl Screws Loose
	2	*		*		*	1	2		Needle Leaking
				*	2					Idle Passages Plugged or Dirty
				*	*	*				Crankcase Vent Valve Plugged
								*	*	Fuel Filter in Gas Tank Plugged
							*	*	1	Fuel Filter in Carburetor Plugged or Dirty, By Passing Fuel
						6				Air Cleaner Element Plugged
								*	4	Hole in Fuel Pump Suction Line or Kinked Hose
		3	*			5				Heat Riser Valve Stuck Open or Closed (350 only)
*	*	*	*	2	*					Secondary Throttle Valves Sticking Open
									*	Check for Full Throttle Position at Carburetor
*		*	2							Accelerator Pump Inoperative
									*	Fuel Tank Vent Plugged