

# SECTION A

## ENGINE FUEL SYSTEM – GENERAL

## CONTENTS

Division	Subject	Paragraph
I	<b>SPECIFICATIONS AND ADJUSTMENTS:</b>	
	Specifications and Adjustments . . . . .	64-1
	Carburetor Idle Speed & Mixture Adjustments . . . . .	64-2
	Throttle Linkage and Dash Pot Adjustments . . . . .	64-3
II	<b>DESCRIPTION AND OPERATION:</b>	
	Description of Engine Fuel System . . . . .	64-4
	Air Cleaner, Fuel Filter and Ventilator Valve Service . . . . .	64-5
III	<b>SERVICE PROCEDURES</b>	
IV	<b>TROUBLE DIAGNOSIS:</b>	
	Hard Starting . . . . .	64-6
	Improper Engine Performance . . . . .	64-7
	Excessive Fuel Consumption . . . . .	64-8

### DIVISION I SPECIFICATIONS AND ADJUSTMENTS

#### 64-1 SPECIFICATIONS AND ADJUSTMENTS

Gasoline Tank Capacity (Approximately)	
Series 43-44000 . . . . .	20 Gal.
Series 45-46-48000 . . . . .	25 Gal.
Series 49000 . . . . .	21 Gal.
Gasoline Gauge, Make & Type . . . . .	A.C. Electric
Fuel Pump, Make . . . . .	A.C.
Fuel Pump, Type & Location	
Riviera . . . . .	Electric, Bottom of Fuel Tank
All other . . . . .	Mechanical, Left Front Engine
Fuel Pump Pressure—At Carb. Level	
250-350 Engines . . . . .	3 Lbs. Min.
455 Engine . . . . .	4-1/2 Lbs. Min.
Fuel Pump Volume . . . . .	1 Pt. in 30 Seconds or Less
Fuel Filter In Carb. Inlet, Make & Type	
1 & 2-Barrel Carb. . . . .	A.C., 1 In. Paper, GF-427
4-Barrel Carb. . . . .	A.C., 2 In. Paper, GF-441
Fuel Filter, in Gas Tank . . . . .	Woven Plastic
Carburetor, Make & Type . . . . .	Rochester, Remote Choke Coil
Air Cleaner, Make & Material . . . . .	A.C., Oiled Paper Element
Air Cleaner Element, Type—Standard	
L-6 Engines . . . . .	A169CW
G. S. Engines . . . . .	A212CW
All Other Engines . . . . .	A329C

<b>Air Cleaner Element, Type—Heavy Duty</b>	
L-6 Engines .....	A227C
G. S. Engines .....	A279C
All Other Engines .....	A368C
<b>Positive Crankcase Ventilator Valve, Type</b>	
L-6 Engine .....	CV-723C
V-8 Engine .....	CV-679C
<b>Intake Manifold Heat, Type</b> .....	
Thermostat Wind-Up @ 70° F., Valve Closed .....	Exhaust Crossover 1/2 Turn
<b>Idle Speed (Automatics in Drive)</b>	
250 Eng.—Manual Transmission .....	750 RPM
250 Eng.—Automatic Transmission .....	600 RPM
350 Eng.—Manual Transmission .....	700 RPM
350 Eng.—Automatic Transmission .....	600 RPM
455 Eng.—Manual Transmission .....	700 RPM
455 Eng.—Automatic Transmission .....	600 RPM
<b>Fast Idle Speed (On Low Step of Cam)</b>	
Automatic Transmission .....	650 RPM
Manual Transmission .....	720 RPM

64A-3

## 64-2 CARBURETOR IDLE SPEED AND MIXTURE ADJUSTMENTS

Carburetor adjustments should not be attempted until it is known that engine ignition and compression are in good order. Any attempt to adjust or alter the carburetor to compensate for faulty conditions elsewhere will result in reduced economy and overall performance.

### a. Idle Speed and Mixture Adjustments

e The air cleaner must be left in place while making idle speed and mixture adjustments. The positive crankcase ventilator system should also be in good operating condition when making carburetor adjustments. Either of these items noticeably affects the air-fuel ratio at idle.

1. Connect an accurate tachometer to engine.

2. Start engine and run it at fast idle until upper radiator inlet is hot and choke valve is wide open.

**CAUTION:** *Idle speed and mixture adjustments cannot be made satisfactorily with an abnormally hot engine. On any engine having a hot idle compensator valve or a thermo vacuum switch, it is particularly important that idle adjustments be made at*

*normal temperature so that these valves will be in normal position.*

3. To insure that thermo vacuum switch does not switch distributor vacuum over to full manifold vacuum due to excessive coolant temperature, always remove vacuum hose from distributor and plug it with a pencil while adjusting idle.

4. On automatic transmission cars, place a block in front of a front wheel and apply parking brake firmly, then shift transmission into drive.

**CAUTION:** *Any car which is equipped with an Automatic Level Control has a vacuum regulator valve which shuts off all vacuum to the air compressor during engine idle, thereby preventing compressor from operating and upsetting engine idle. Feel compressor with hand; if it is operating, this malfunction must be fixed before adjusting engine idle. See Group 40, Section B.*

5. On V-8 engines, adjust throttle stop screw to set idle speed according to specifications listed above.

6. Adjust idle mixture needles, one at a time, to obtain highest tachometer reading. After highest reading is reached using mixture needles, readjust throttle stop screw as required to obtain 20 RPM faster than specified idle. Next turn *each* mixture needle

in (lean) as required to reduce engine speed 10 RPM. This reduces idle speed to the recommended RPM.

7. On L-6 engines adjust solenoid plunger screw to set specified idle speed. Stop engine.

8. Turn mixture screw *in* until it contacts seat lightly, then back *out* four (4) full turns.

9. Disconnect and plug distributor vacuum line, start engine, set ignition timing.

10. Re-adjust *solenoid* screw to 830 RPM (man in neutral) or 630 RPM (auto in drive).

11. Adjust mixture screw *in* to achieve specified idle speed, reconnect vacuum line.

**NOTE:** *This method of adjusting idle mixture must be used on all cars to keep hydrocarbon and carbon monoxide emissions to a minimum.*

12. Adjust fast idle speed on all two-barrel and four-barrel carburetors. Fast idle must be adjusted after slow (curb) idle speed and mixture have been adjusted. Automatic transmission cars are adjusted on the low step of the fast idle cam in Drive to 620 RPM. Manual transmission cars are adjusted on the low cam step to 720 RPM.

**64-4 ENGINE FUEL SYSTEM GENERAL****b. L-6 Engine Throttle Stop Screw Adjustment**

The normal idle speed adjustment is made by adjusting the length of the idle stop solenoid plunger. This solenoid is energized electrically whenever the ignition switch is on; when energized, the solenoid plunger extends to contact the throttle lever and determine idle speed.

When the ignition switch is turned off, however, the solenoid plunger pulls-in so that the throttle lever cannot reach it. With ignition off, then, the throttle lever closes farther until it contacts the carburetor throttle stop screw.

In this position the throttle valve is nearly closed so that the air-fuel mixture is nearly shut-off. This shutting-off of the air-fuel mixture is necessary on L-6 engines to prevent dieseling (after-run with ignition off).

Adjustment of the carburetor throttle stop screw is necessary to make sure the throttle valve does not close tight in the carburetor bore, which could cause jamming with resulting damage to the throttle valve and bore. Adjust carburetor throttle stop screw as follows:

1. Make sure normal idle speed and mixture adjustments are correct as described in subparagraph a above.
2. Disconnect wire from idle stop solenoid to de-energize solenoid. Adjust carburetor throttle stop screw to obtain 400 RPM (automatic or manual transmission). Do not touch mixture or idle stop solenoid screws.
3. Reconnect wire to solenoid. Accelerate engine slightly to allow solenoid to extend, then recheck normal idle speed.

**64-3 THROTTLE LINKAGE AND DASH POT ADJUSTMENTS**

Series 43-44000 Buicks have a flexible cable type throttle linkage.

Series 45-46-48-49000 Buicks have the rod type throttle linkage. Automatic transmission cars do not have an idle stator switch because the "switch-the-pitch" feature is no longer in any automatic transmission. There is still a downshift mechanism which is operated by the throttle linkage. Automatic transmission cars also have a dash pot which delays the closing action of the throttle to reduce any possibility of the engine stalling on a sudden deceleration.

**a. Throttle Linkage Adjustments**

**NOTE:** *The flexible cable type linkage on Series 43-44000 is not adjustable.*

1. Remove air cleaner. Check throttle linkage for proper lubrication. Make sure that linkage is free in all positions and that nothing touches or interferes with the linkage. Hold choke open and make sure that return spring fully closes throttle, even though throttle is released very slowly.
2. Adjust engine idle speed and mixture. See paragraph 64-2. With throttle linkage in hot curb idle position, measurement from throttle rod pin horizontally to dash must be 5-7/8 inches 1/4 inch (Series 45-46-48000) or 6-1/8 inches 1/4 inch (Series 49000). If measurement is off, shorten or lengthen throttle rod as required to correct. See Figure 64- 2 and 3.
3. Operate linkage to open carburetor and make sure carburetor wide open stop is contacting.
4. As a final check, have a helper depress accelerator pedal and check to make sure wide open stop contacts at carburetor.

**b. Dash Pot Adjustments**

Before adjusting the dash pot, the engine idle speed and mixture should be correctly adjusted. With the engine idling at normal operating temperature, adjust the dash pot as follows:

1. While observing dash pot, open carburetor and allow throttle to snap closed. Time dash pot delaying action from the point where the throttle lever hits the dash pot to the point where the lever stops moving. The dash pot should delay or cushion closing action for two seconds on 4 BBL. carburetors, and one second on 2 BBL. carburetors. Measure two seconds by saying, "one thousand and one, one thousand and two."
2. As a final check, hold car with brakes and put transmission in drive, then jab accelerator pedal. If engine stalls, adjust dash pot for slightly more interference and recheck as necessary.
3. Tighten lock nut securely.

**DIVISION II****DESCRIPTION AND OPERATION****64-4 DESCRIPTION OF ENGINE FUEL SYSTEM****a. Fuel Filter**

All engines have a pleated paper fuel filter located in the carburetor inlet.

All cars have a woven plastic fuel filter in the fuel tank on the lower end of the pick-up pipe.

**b. Fuel Pump**

The fuel pump is mounted at the lower left side of the timing chain cover. (Rivieras have an electric fuel pump mounted in the bottom of the fuel tank.) It is actuated by an eccentric mounted on the front end of the camshaft. The pump is inverted, thereby placing it in a lower, cooler location. It has a built-in air pocket to dampen out pulsations in fuel pressure. The construction and operation of the fuel pump are described in Section 64-B.



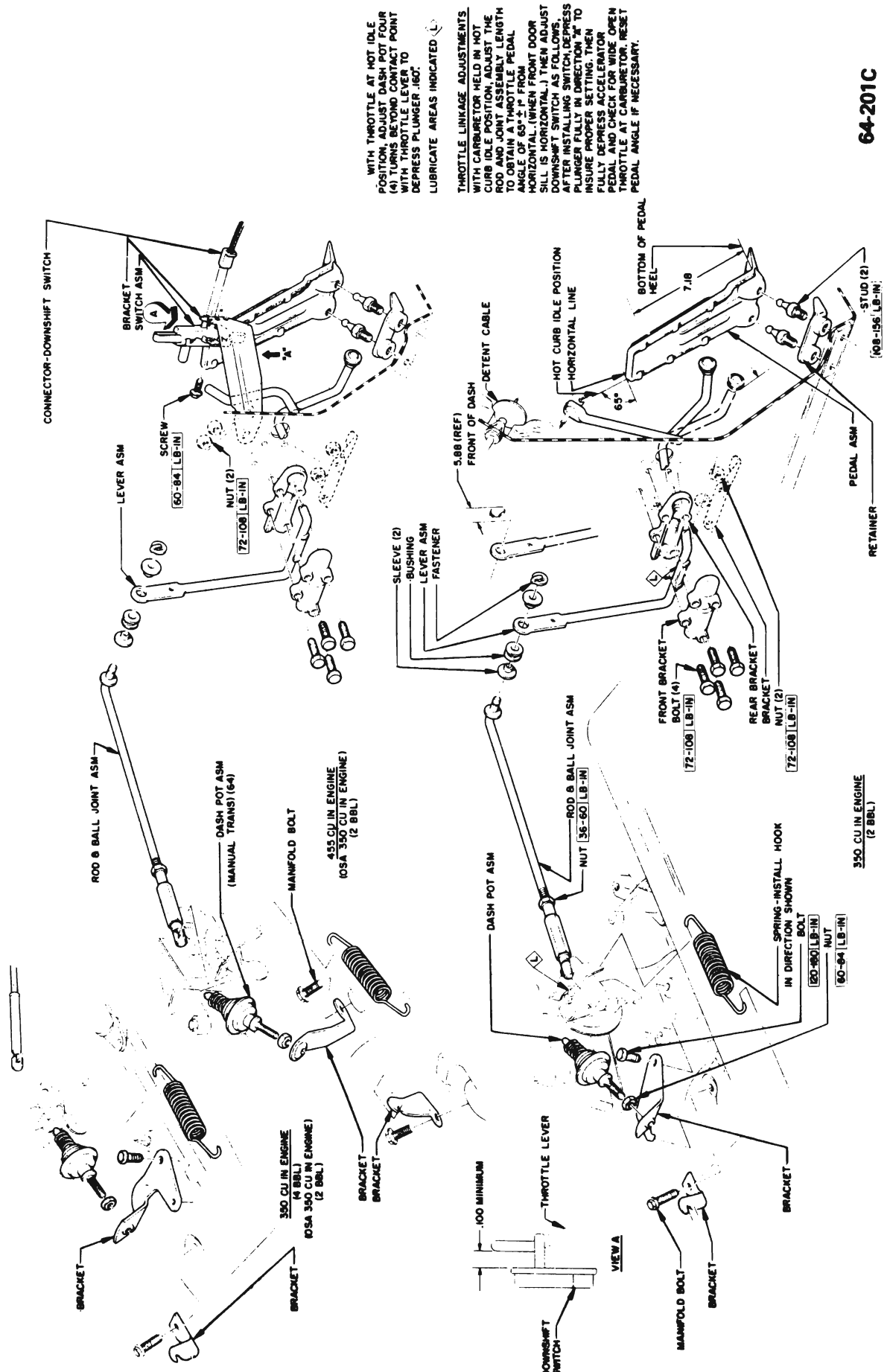

WITH THROTTLE AT HOT IDLE POSITION, ADJUST DASH POT FOUR (4) TURNS BEYOND CONTACT POINT WITH THROTTLE LEVER TO DEPRESS PLUNGER .160". LUBRICATE AREAS INDICATED (L).

THROTTLE LINKAGE ADJUSTMENTS WITH CARBURETOR HELD IN HOT CURB IDLE POSITION, ADJUST THE ROD AND JOINT ASSEMBLY LENGTH TO OBTAIN A THROTTLE PEDAL ANGLE OF 65° ± P FROM HORIZONTAL. (WHEN FRONT DOOR SILL IS HORIZONTAL.) THEN ADJUST DOWNSHIFT SWITCH AS FOLLOWS. AFTER INSTALLING SWITCH, DEPRESS PLUNGER TO DEPRESS THROTTLE. INSURE POWER RESISTANCE TO PULL DEPRESS RESISTANCE TO PEDAL AND CHECK FOR WIND UP. THROTTLE AT CARBURETOR. RESET PEDAL ANGLE IF NECESSARY.

64-201C

Figure 64-2 · Throttle Linkage · 45-46-48000

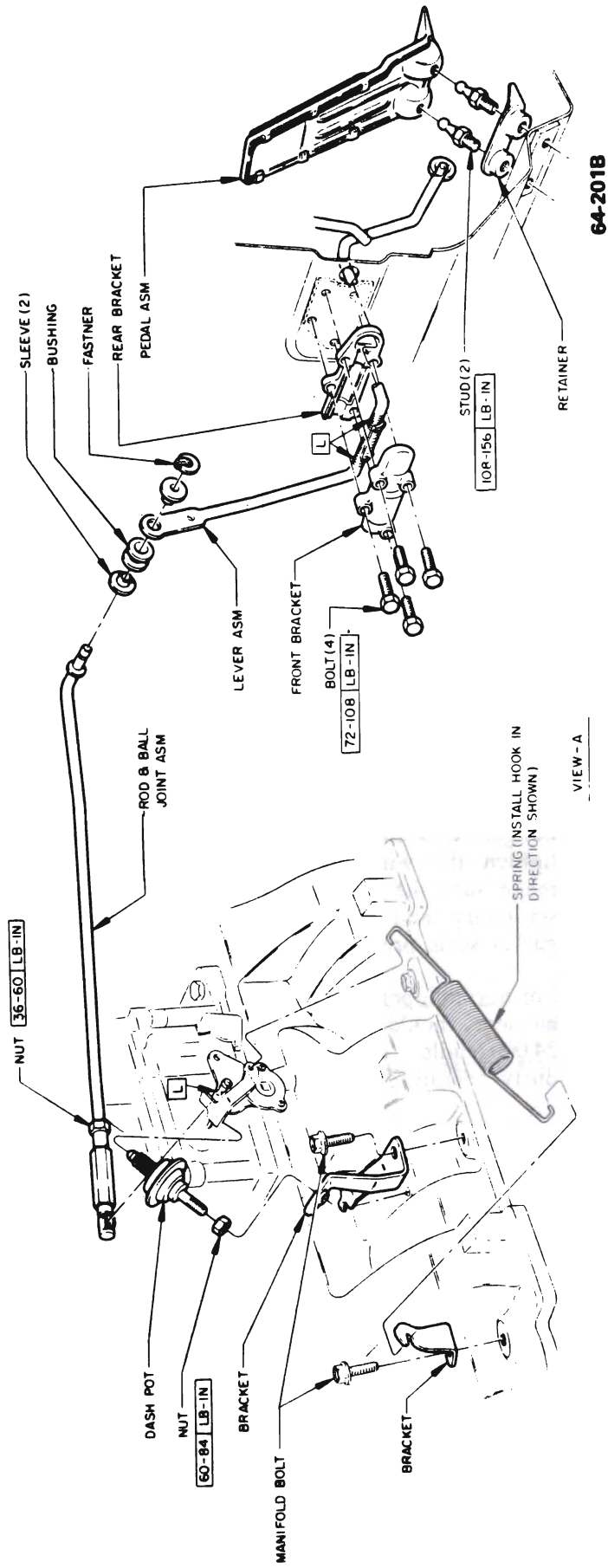

Figure 64-3 · Throttle Linkage · 49000

All V-8 air conditioner equipped cars (except Rivieras) have a special fuel pump which has a metering outlet for a vapor return system. Any vapor which forms is returned to the fuel tank along with hot fuel through a separate line alongside the supply line. This greatly reduces any possibility of vapor lock by keeping cool fuel from the tank constantly circulating through the fuel pump. All 455 engines (except in Rivieras) have the vapor return system regardless of whether or not the car is equipped with an air conditioner.

Rivieras have a turbine type electric fuel pump located at the lower end of the fuel pick-up pipe in the bottom of the fuel tank. This fuel pump runs continuously whenever the engine is running, maintaining a steady pressure whether fuel is needed or not.

The electrical supply circuit is not complete to the pump when the ignition is turned on. This supply circuit is controlled by a special oil pressure switch which has two sets of contacts. One set of contacts is closed and the other is open when no oil pressure is present; when oil pressure is over 3 lbs., the open and closed contacts are reversed. During engine cranking, with no oil pressure, the fuel pump circuit is from the starter solenoid, through the oil pressure switch to the fuel pump; after the engine starts, with oil pressure, the circuit is from the ignition switch, through the other oil pressure switch contacts to the fuel pump. See Figure 64-4.

The fuel pump will not operate if the ignition switch is accidentally left on, thereby avoiding possible engine flooding due to a leaky needle and seat. Also, if the engine should stop due to an automobile accident, the fuel pump will not operate. As an added protection against engine damage, if oil pressure is low for any reason, the fuel pump will not operate and the engine will stop running.

#### c. Air Cleaner and Intake Silencer

All engines are equipped with oiled paper element air cleaners as standard equipment; the optional heavy duty air cleaner is identical except that it contains a two layer element of oiled polyurethane and oiled paper. The air cleaner removes abrasive dust and dirt from the air before it enters the engine through the carburetor. The intake silencer reduces to a very low level the roaring noise made by the air as it is drawn through the intake system. The cleaner and silencer also functions as a flame arrester in event of "backfire" through the intake system.

There are five standard air cleaner and silencer assemblies: one for L-6 engines, one for 350 two-barrel carburetor engines, one for standard four-barrel carburetor engines, one for G.S. 350-455 engines and one for G.S. Riviera engines.

Before installing an air cleaner, always make sure the air cleaner gasket is in good condition and is properly located on the carburetor flange. It is important to securely tighten the wing nut *by hand* to make sure the air cleaner remains stationary and to make sure the gasket seals properly.

For normal operating conditions, the element should be replaced every 24,000 miles (more often under dusty operating conditions).

#### d. Carburetor Throttle Control Linkage (Upper Series)

The carburetor throttle control linkage is designed to provide positive control of the throttle valves through their entire range without being affected by movement of the engine on its rubber mountings. See Figure 64-2 or 3.

The accelerator pedal is mounted on two ball studs which are screwed into weld nuts in the floor pan. Depressing the accelerator pedal causes the pedal to make a rolling contact with a roller on the throttle operating lever, forcing the lower part of the

lever to pivot forward and down. The lever pivots in a bearing mounted on the body cowl. See Figure 64-2 or 3.

As the lower part of the throttle operating lever is pushed forward by the accelerator pedal, the upper part of the lever is pulled rearward. This pulls the throttle rod rearward, causing the carburetor throttle lever to open the throttle valves.

The return spring returns the throttle linkage to idle position whenever pressure is released from the accelerator pedal. See Figure 64-2 or 3.

On all automatic transmission cars, a dash pot is mounted in position to be contacted by an arm of the carburetor throttle lever as the throttle is closed. The dash pot cushions the closing of the throttle to prevent engine stalling when the accelerator pedal is suddenly released.

On all automatic transmission cars, a transmission downshift mechanism is mounted inside the car just above the accelerator pedal. When the accelerator pedal is moved to wide open throttle position (fully depressed), the mechanism operates, causing the transmission to "downshift". See Figure 64-1 thru 3.

## 64-5 AIR CLEANER, FUEL FILTER AND VENTILATOR VALVE SERVICE

### a. Air Cleaner Service

An air cleaner with a dirty element will not properly remove dirt from the air and the dirt entering the engine will cause abnormal formation of carbon, sticking valves, and wear of piston rings and cylinder bores.

Regular replacement of the element at 24,000 mile intervals (or more frequently in dusty territory) is necessary to prevent excessive engine wear.

64-202B

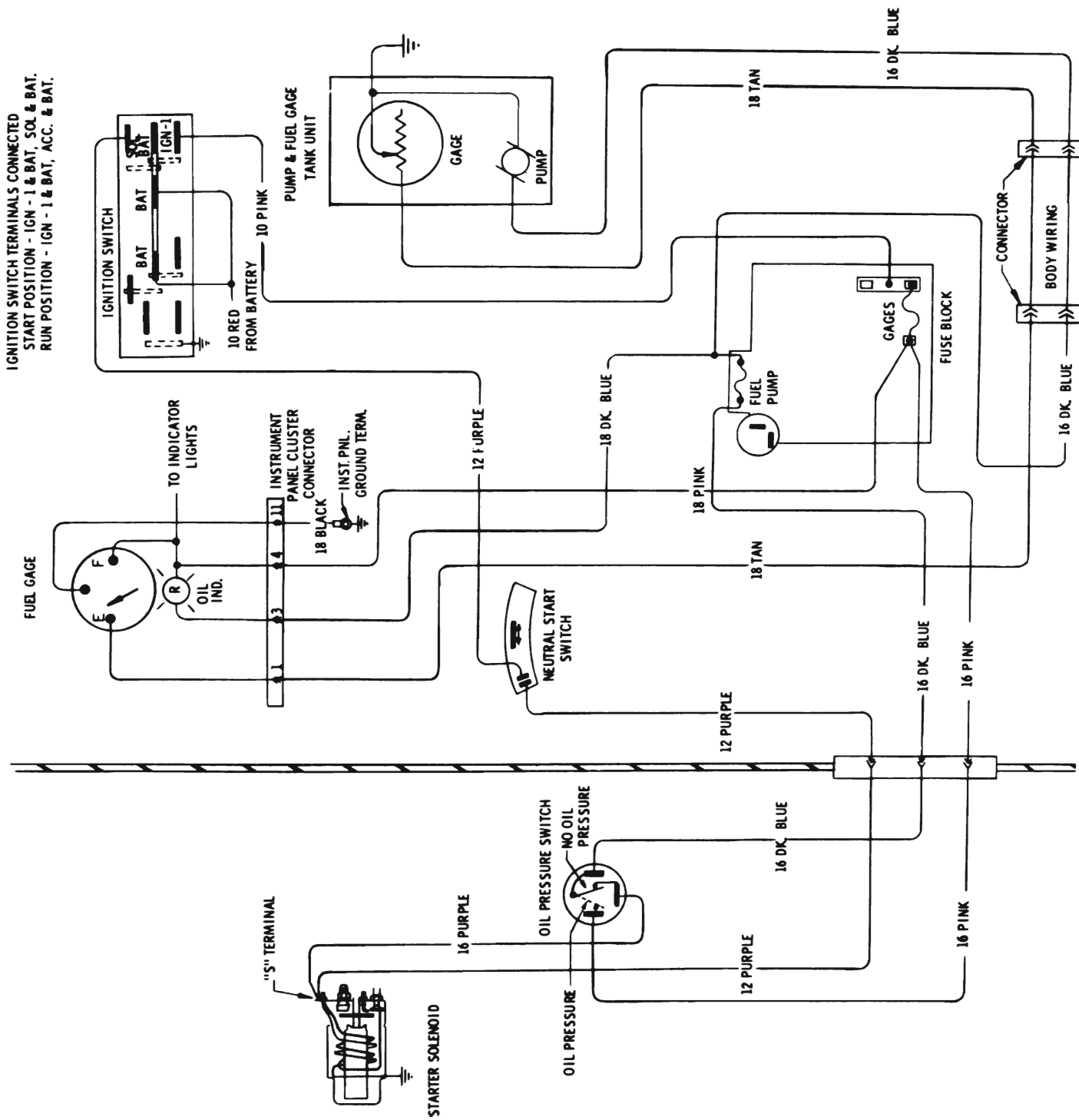

Figure 64-4 - Electric Fuel Pump Circuit Diagram

PART OF INSTRUMENT PANEL HARNESS



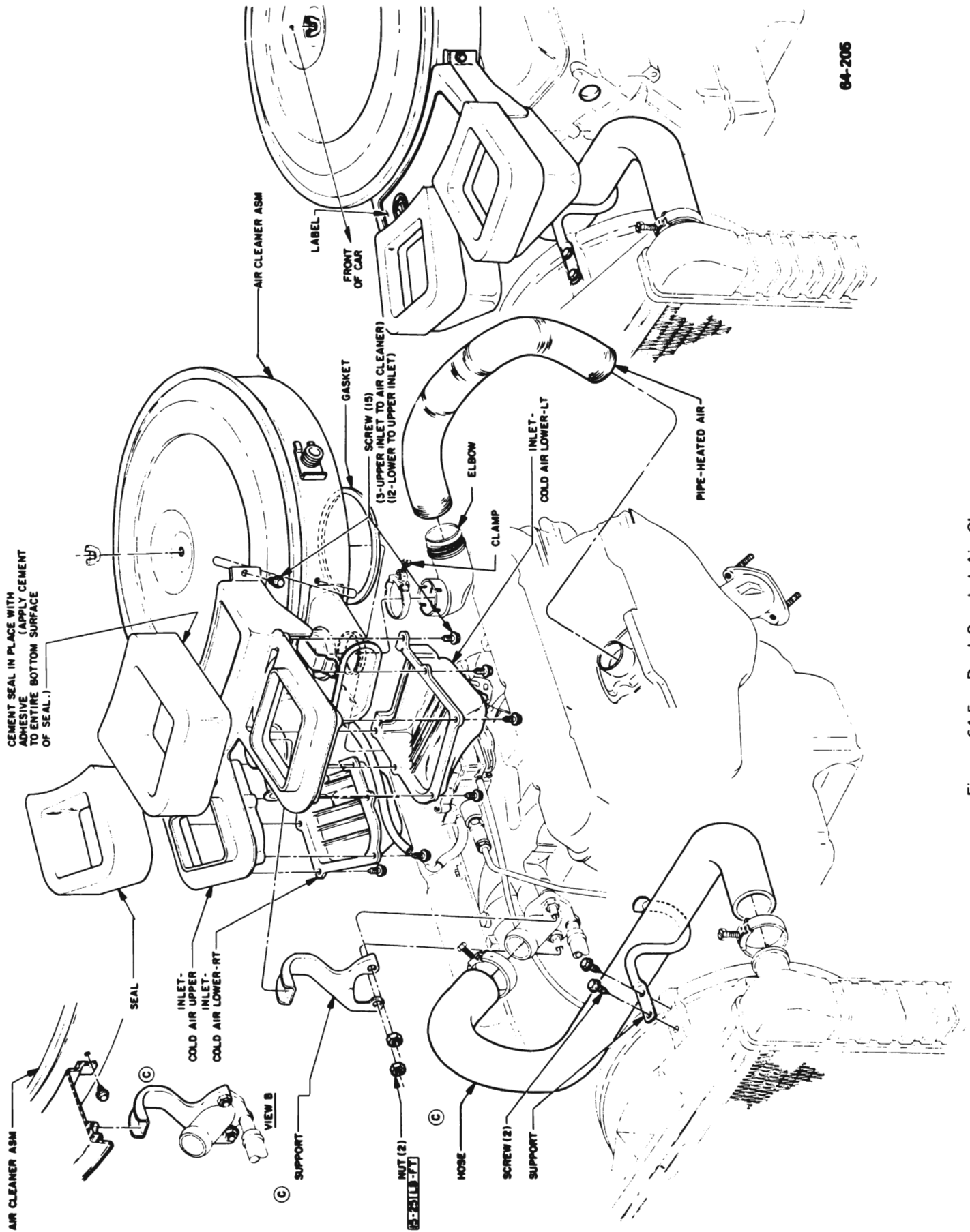

Figure 64-5 - Dual Snorkel Air Cleaner

### b. Fuel Filter--All Engines

All engine fuel filters are located in the carburetor fuel inlet. See Figure 64-6. These fuel filter elements are of pleated paper. Elements are placed in the inlet hole with the cupped end outward. A spring holds the element outward, sealing it by compressing a gasket surface against the inlet fitting. If the element should ever become plugged, pump pressure is sufficient to depress the spring slightly so that some fuel bypasses the element. Thus, a plugged element, instead of causing a car stoppage on the road, allows the engine to continue running on unfiltered fuel. However, the spring pressure is designed to allow only enough fuel to by-pass to let the car run 50 to 60 MPH at a constant speed, or to cut-out at a much lower speed with heavy acceleration. If surging is encountered in the 50 to 60 MPH range, try several hard accelerations; if the engine also runs out of fuel during acceleration, the problem is insufficient fuel, and the most likely reason is a plugged filter. If the owner has "put-up" with this trouble for some time, there is probably dirt in the carburetor due to usage of unfiltered fuel and also due to "dumping" of dirt from the plugged filter element.

The carburetor inlet fuel filter should be replaced every 12,000 miles.

After assembling any filter element in the carburetor, always start the engine and check for leaks in the fuel line and fittings before installing the air cleaner.

### c. Other Filters or Strainers

A woven plastic filter is located on the lower end of the fuel pickup pipe in the gas tank. This filter prevents dirt from entering the fuel line and also stops water unless the filter becomes completely submerged in water. This filter is self cleaning and normally requires no maintenance. Fuel stoppage at this point indicates that the gas tank contains an

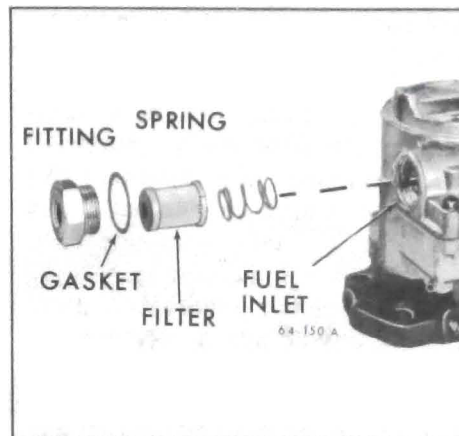

Figure 64-6 - Fuel Filter Parts

abnormal amount of sediment or water; the tank should therefore be removed and thoroughly cleaned.

### d. Closed Positive Crankcase Ventilator System Service

All cars have a closed positive crankcase ventilating system to help reduce air pollution and to provide more complete scavenging of crankcase impurities. Ventilation air is drawn through a filter assembly located in the air cleaner, through a hose, into the left rocker arm cover, down into the crankcase, across and up into the rear of the intake manifold, up through the ventilator valve, through a hose, and into the intake manifold. Intake manifold vacuum draws any fumes from the crankcase to be burned in the engine. See Figure 64-8.

When air flow through the carburetor is high, added air from the positive crankcase ventilating system has no noticeable effect on engine

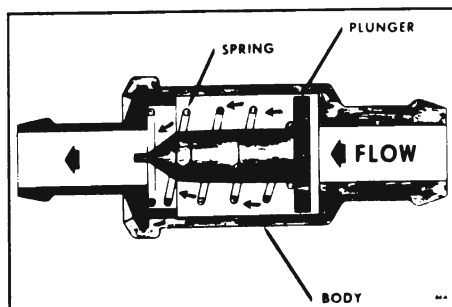

Figure 64-7 - Positive Crankcase Ventilator Valve

operation; however, at idle speed, air flow through the carburetor is so low that any large amount added by the ventilating system would upset the air fuel mixture, causing rough idle. For this reason, a flow control valve is used which restricts the ventilating system flow whenever intake manifold vacuum is high. See Figure 64-7.

After a period of operation, the ventilator valve tends to become clogged, which reduces and finally stops all crankcase ventilation. An engine which is operated without any crankcase ventilation can be damaged seriously. Therefore, it is important to replace the ventilator valve periodically.

**CAUTION:** *If an engine is idling too slow or rough, this may be caused by a clogged ventilator valve or a hose; therefore, never adjust the carburetor idle without first checking the crankcase ventilator check valve and hose.*

With the crankcase ventilator system operating normally, about 1/4 of the air used in the idle mixture is supplied through the ventilator valve. Therefore, if the ventilator air is shut off, the idle speed will be noticeably slower. Check operation of the ventilator system as follows:

1. Connect a reliable tachometer and adjust idle as specified.
2. Squeeze-off crankcase ventilator hose to stop all air flow.
3. If idle speed drops 60 RPM or more, crankcase ventilator system is okay.
4. If idle speed drops less than 60 RPM, ventilator system is probably partially clogged; install a new ventilator valve and recheck operation of system as described above.
5. After installing a new ventilator valve, always readjust engine idle.

All cars have a closed P.C.V. system. With this system, any blow-by in excess of the system capacity (from a badly worn engine, sustained heavy

**64-12 ENGINE FUEL SYSTEM GENERAL**

load, etc.) is exhausted into the air cleaner and is drawn into the engine.

**e. P.C.V. Filter**

Inspect positive crankcase ventilator filter every 4 months or 6000 miles and replace if necessary. Remove filter from inside air cleaner by removing breather hose clamp, breather hose and filter retainer clip. See Figure 64-8.

**DIVISION IV****TROUBLE DIAGNOSIS****64-6 HARD STARTING****a. Improper Starting Technique**

Hard starting may be due to improper starting technique. If possible, observe the owner's method of starting; if not correct, suggest that he use the following procedure.

1. *Automatic Transmission.* Place control lever in "P" or "N" position. Starter cannot be operated in any other position.

*Manual Transmission.* Place control lever in neutral and depress clutch pedal to floor. Starter cannot be operated unless clutch pedal is depressed.

2. *Engine Cold.* Depress accelerator pedal to floor once, release and remove foot completely from accelerator pedal. This presets the automatic choke and throttle.

*Engine Warm* Hold accelerator pedal about 1/3 down.

3. Turn ignition switch to "START" and release when engine starts. As soon as the engine is running smoothly, "jab" the accelerator pedal to slow the engine down to warm up speed.

If the engine is warm, but fails to restart promptly, there may be an excess of fuel or "flooding". (This is

more likely to occur at low temperatures)

*Flooding.* Hold the accelerator pedal to the floor (fully depressed) while cranking the engine; this opens the choke to "unload" any excess fuel. When the engine fires, do not immediately release the accelerator pedal, but hold it down until the engine speed increases.

If the engine has not been started for several days, most of the fuel will have evaporated from the carburetor. Pumping the accelerator pedal, while cranking, will pump fuel directly into the engine which will hasten the start.

**b. Improper Ignition**

Before attempting any correction in fuel system make certain that the battery and ignition system are in proper condition. See paragraph 120-4 and 68-28.

**c. Improper Adjustment of Fast Idle Cam or Choke Unloader**

An incorrectly adjusted fast idle cam may not provide sufficient throttle opening and stalling will result.

If the choke unloader goes into action too soon it may cause hard starting when engine is cold. If choke unloader goes into action too late or not at all, it may cause hard starting when engine is flooded.

**d. No Fuel at Carburetor**

Fuel may not be delivered to carburetor due to empty gasoline tank or stoppages in filters, strainers or feed hoses, or inoperative fuel pump. Test fuel supply as described in paragraph 64-10.

**e. Improper Carburetor Adjustment**

Improper setting of carburetor idle needle valve s may cause stalling after starting. A high fuel level in float bowl will cause flooding and consequent hard starting. Adjust carburetor (par. 64-2).

**f. Low Grade Gasoline**

Low grade gasoline is usually insufficiently volatile to provide easy starting in cold weather even though it may perform reasonably well after the engine is started and warmed up. A change to high grade gasoline is the only remedy.

**g. Volatile Gasoline**

In some parts of the country, gasolines are marketed which are very volatile and generally advertised as "easy starting gasolines." Some of these fuels are so volatile they boil (commonly referred to as "percolation") in a carburetor bowl which is only normally warm, especially when the engine is shut off following a run. This overloads the manifold, resulting in an over rich mixture which may cause "delayed" starting.

**64-7 IMPROPER ENGINE PERFORMANCE****a. Engine Idles Too Fast**

A cold engine should operate on fast idle for two to five minutes depending on air temperature. At 32 F. the fast idle cam should move to slow idle position in approximately 1/2 to 1 1/4 mile of driving. At high temperatures it should move to slow idle position in a correspondingly shorter distance.

If the engine operates too long on the fast idle cam, check the choke coil ro setting and the fast idle d cam adjustment.

If the engine idles faster than the specified idle speed when off the fast idle cam, check throttle linkage for binding or weak return spring and adjust throttle stop screw (par. 64-3). This trouble can also be caused by a sticking choke.

**b. Improper Idle and Low Speed Performance**

Rough idling and tendency to stall

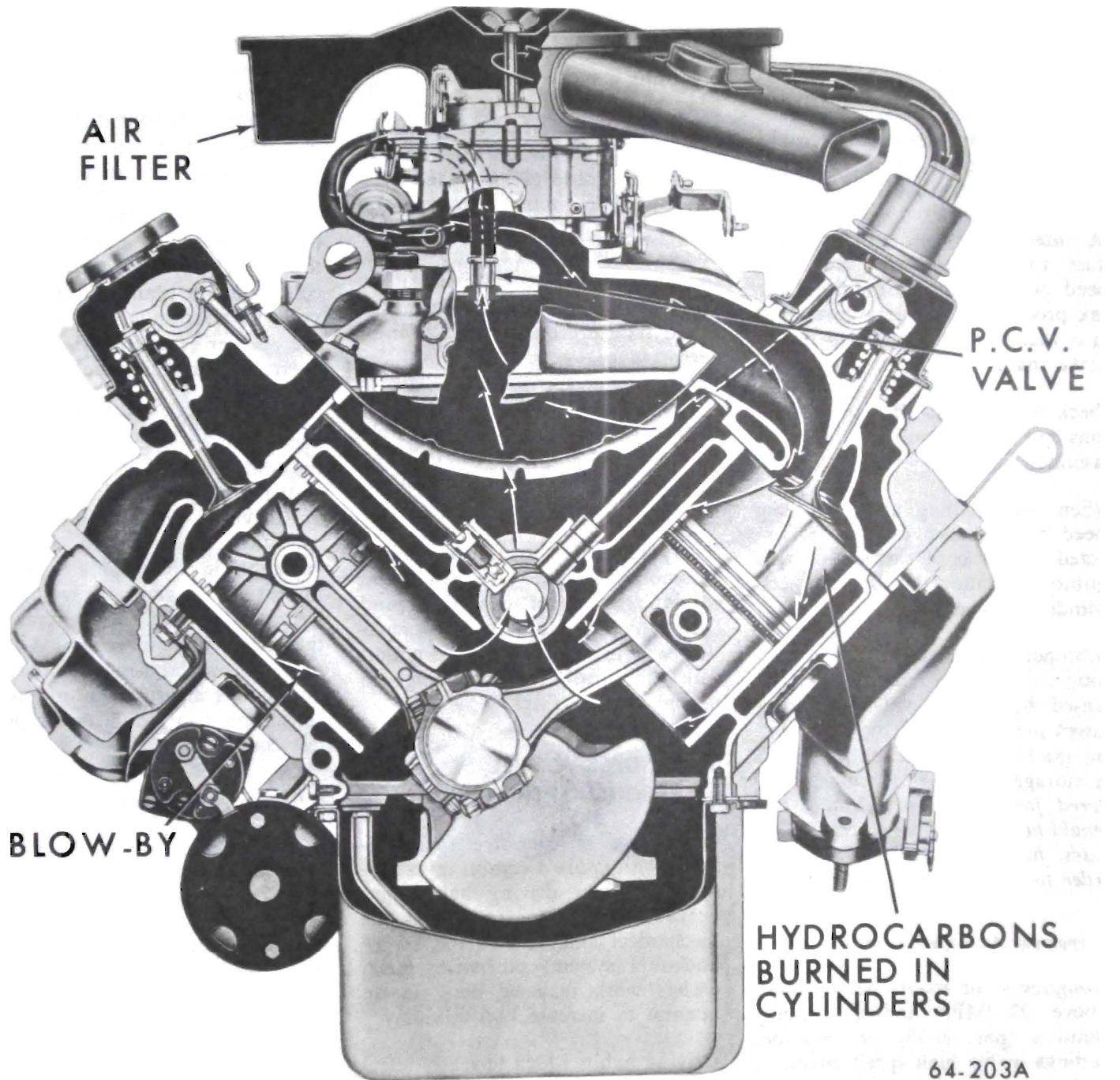

Figure 64-8 · Positive Crankcase Ventilator System

**64-14 ENGINE FUEL SYSTEM GENERAL**

may be caused by idling speed set below the specified idle speed. Idle mixture may be wrong due to improper needle valve adjustment (par. 64-2).

Rough idling, poor performance, and back firing at low speeds frequently originates in improper ignition. Check ignition system.

High fuel pump pressure will cause rough idling and poor low speed performance (par. 64-11).

An intake manifold air leak will cause rough idling and poor low speed performance. A manifold air leak produces a low, erratic reading on a vacuum gage connected to the intake manifold.

Check for leaks at all pipe connections and check manifold joints with gasoline.

When rough idling and poor low speed performance cannot be corrected by checks of carburetion and ignition mentioned above, check cylinder compression.

Improper performance which is most noticeable at low speeds may be caused by sticking valves. Sticking valves may be caused by the use of low grade fuel or fuel that has been in storage too long. *When a car is stored for any length of time, fuel should be drained from the tank, feed hoses, fuel pump, and carburetor in order to avoid gum formation.*

**c. Improper High speed Operation**

Roughness or poor performance above 22 MPH indicates faulty ignition (par. 10-33) or improper settings in the high speed circuit of carburetor. Surging at high speed may be caused by low fuel pump pressure (par. 64-11).

Surging at 75 to 80 MPH constant speed indicates that the power jet is stopped up or the vacuum piston is sticking.

If there is lack of power at top

speed, check throttle linkage to insure full throttle valve opening (par. 64-3).

**d. Excessive Detonation or Spark Knock**

*Light detonation* may occur when operating a synchromesh car in high gear with full throttle between 14 and 22 MPH, or when operating an automatic transmission car in Drive with full throttle at low speed even when ignition timing is correct and proper fuel is used. This light detonation is normal and no attempt should be made to eliminate it by retarding the ignition timing, which would reduce economy and over-all performance.

*Heavy detonation* may be caused by improper ignition timing (par. 68-24), improper grade of fuel, or by an accumulation of carbon in combustion chambers.

Heavy detonation is injurious to any automotive engine. A car driven continuously under conditions and fuels which produce heavy detonation will overheat and lose power, with the possibility of damage to pistons and bearings.

**64-8 EXCESSIVE FUEL CONSUMPTION**

Complaints of excessive fuel consumption require a careful investigation of owner driving habits and operating conditions as well as the mechanical conditions of the engine and fuel system; otherwise, much useless work may be done in an attempt to increase fuel economy.

Driving habits which seriously affect fuel economy are: high speed driving, frequent and rapid acceleration, driving too long in a low speed range when getting under way, excessive idling while standing.

Operating conditions which adversely affect fuel economy are: excessive acceleration, frequent starts and stops, congested traffic,

poor roads, hills and mountains, high winds, low tire pressures.

High speed is the greatest contributor to low gas mileage. Air resistance increases as the square of the speed. For instance, a car going sixty miles an hour must overcome air resistance four times as great as when going thirty miles an hour. At eighty miles an hour the resistance is over seven times as great as when going thirty miles an hour.

Over seventy-five per cent of the power required to drive a car eighty miles an hour is used in overcoming air resistance, while at thirty miles an hour only thirty per cent of the power required is used to overcome air resistance.

Gas mileage records made by car owners never give a true picture of the efficiency of the engine fuel system since they include the effects of driving habits and operating conditions. Because of the wide variation in these conditions, it is impossible to give average mileage figures for cars in general use; therefore, any investigation of a mileage complaint must be based on an accurate measurement of gasoline consumption per mile under proper test conditions.

**a. Gasoline Mileage Test**

A gas mileage test should be made with an accurate measuring device on a reasonably level road, at fixed speeds, without acceleration or deceleration. Test runs should be made in both directions over the same stretch of road to average the effect of grades and wind resistance. Test runs made at 30-50 and 70 MPH will indicate the approximate efficiency of the low speed, high speed, and power systems of the carburetor and show whether fuel consumption is actually abnormal. If a mileage test indicates that the fuel consumption is above normal, check the following items.

1. *Fuel Leaks.* Check all gasoline hose connections, fuel pump, gasoline

filter, and carburetor bowl gasket.

2. *Tires.* Check for low tire pressures.

3. *Brakes.* Check for dragging brakes.

4. *Ignition Timing--Spark Plugs.* Late ignition timing causes loss of power and increases fuel consumption. Dirty or worn out spark plugs are wasteful of fuel.

5. *Low Grade Gasoline.* Use of gasoline of such low grade that ignition timing must be retarded to avoid excessive detonation will give

very poor fuel economy.

6. *Air Cleaner.* Check for dirty or clogged cleaner element (par. 64-5).

7. *Automatic Choke.* Check for sticking choke valve and improper setting of choke coil rod.

8. *Valves.* Check for sticking valves.

9. *Fuel Pump.* Check for excessive fuel pump pressure (par. 64-10).

10. *Carburetor Adjustment.* Check idle adjustment (par. 64-1).

For all other adjustments to high speed and power systems, the carburetors must be removed and disassembled.

#### **b. Changing Carburetor Calibrations**

*Under no circumstances should the jet sizes, metering rods or other calibrations of a carburetor be changed from factory specifications.* The calibrations given in the calibrations paragraph must be adhered to unless these are later changed by a bulletin issued from the Buick Service Department.