

SECTION J

POSITIVE TRACTION FOR THE TYPE "C" DIFFERENTIAL

CONTENTS

Division	Subject	Paragraph
I	SPECIFICATIONS AND ADJUSTMENTS: Lubrication of Positive Traction Differential.....	40-51
II	DESCRIPTION AND OPERATION: Description of Positive Traction Differential..... Operation of Positive Traction Differential.....	40-52 40-53
III	SERVICE PROCEDURES: Positive Traction Differential Service Procedures Positive Traction Differential Flushing Procedure	40-54 40-55
IV	TROUBLE DIAGNOSIS: Testing the Positive Traction Differential.....	40-56

40-1-1

DIVISION I

SPECIFICATIONS AND ADJUSTMENTS

NOTE: All specifications and adjustments, except for the lubricant used are the same as those listed in Section I for the standard differential.

40-51 LUBRICATION OF POSITIVE TRACTION DIFFERENTIAL

The lubricant level should be checked every 6,000 miles and maintained to a point full to 1/4 inch below the bottom of the filler plug opening by adding Special Positive Traction Lubricant (SAE 90 gear lube meeting specification for GM Part No. 1050081) or equivalent if necessary. Never use standard dif-

ferential lubricant in a Positive Traction Differential.

Positive Traction Differentials can readily be identified by the letter "E" metal stamped under the code number on the front of the right axle tube which is approximately three inches outboard of the carrier as well as by a red plastic tag attached to the filler plug.

The lubricant capacity of this differential assembly is 3-1/2 pints.

DIVISION II

DESCRIPTION AND OPERATION

40-52 DESCRIPTION OF POSITIVE TRACTION DIFFERENTIAL

Positive Traction Differentials are optional equipment on all Buicks. It is designed to perform all the desirable functions of a conventional differential and at the same time overcome its limitations. With a conventional differential, when one wheel is on a slippery surface, its pulling power is limited by the wheel with the lowest traction. Unlike the conventional differential, with the Positive Traction device, the anti-spinning action is limited by the wheel having the best traction, thus limiting the possibility of becoming stuck.

The Positive Traction differential case is designed to incorporate two clutch packs, two spring retainers and four preload springs which are not used in the standard differential case.

Buick Positive Traction Differential

is not a fully locking type and will release before excessive driving force can be directed to one rear wheel. The safety value of this feature eliminates the possibility of dangerous steering reaction. When the rear wheels are under extreme unbalanced tractive conditions, such as having one wheel on ice and the other on dry pavement, wheel spin can occur if over-acceleration is attempted. However, even when wheel spin does occur, the major driving force is directed to the non-spinning wheel.

Another advantage of the Positive

Traction Differential is that on uneven surfaces such as railroad tracks, chuck holes, etc., wheel action is not adversely affected. During power application on a conventional differential, when one wheel hits a bump and bounces clear of the road, it spins momentarily. When this rapidly spinning wheel again contacts the road, the sudden shock may cause the car to swerve. This action is also hard on tires and the entire drive train. With a Positive Traction Differential the free wheel rotates at the same speed as the wheel on the road, thereby minimizing adverse effects.

40-53 OPERATION OF POSITIVE TRACTION DIFFERENTIAL

The Positive Traction Differential has pinion gears and side gears which operate in a manner similar to those in a conventional differential. The Positive Traction unit has a clutch pack installed behind each side gear. These clutch packs are statically spring preloaded to provide an internal resistance to the differential action within the case itself. See Figure 40-202. This preload assures an adequate amount

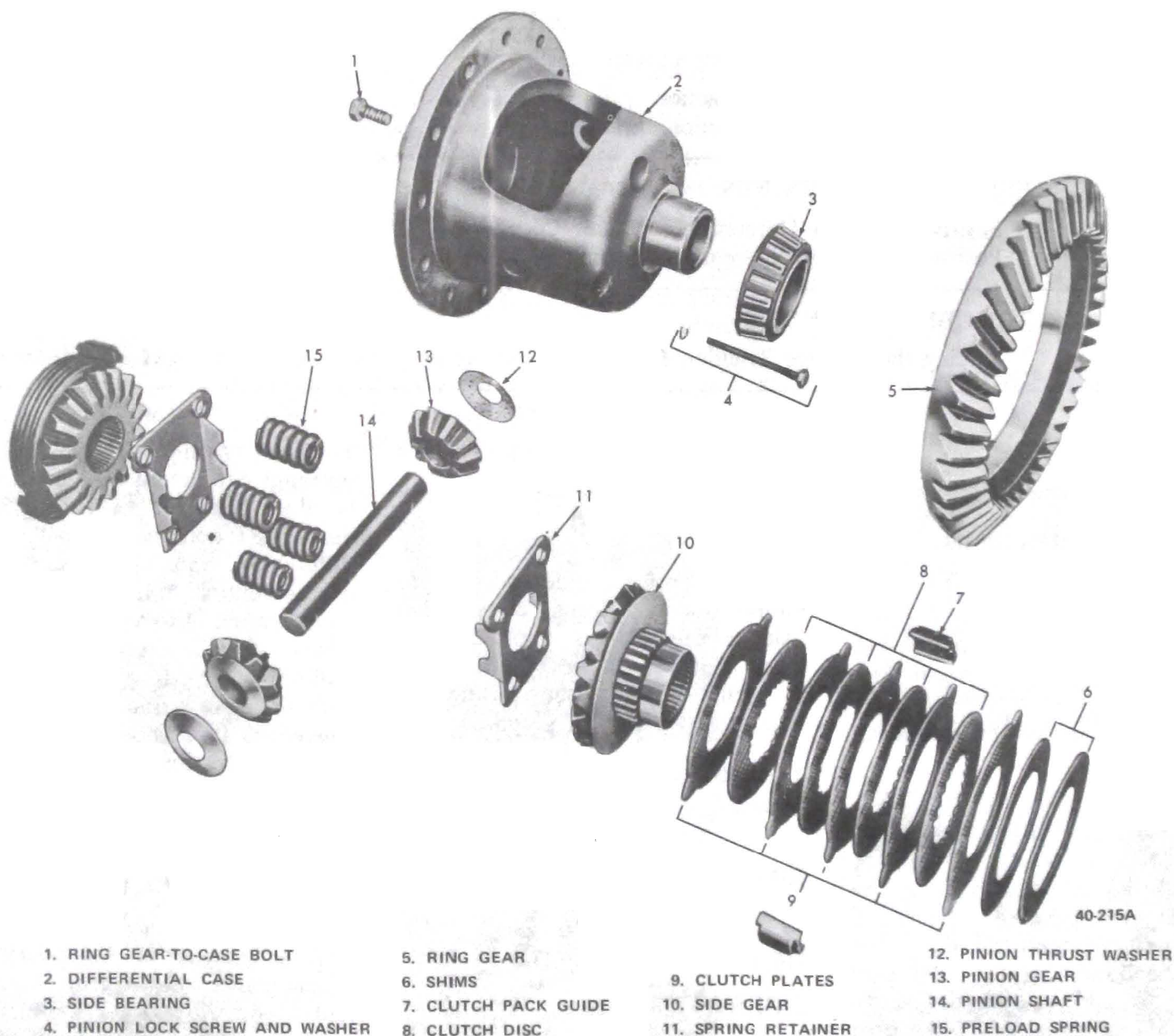

Figure 40-202 · Positive Traction for the Type 'C' Differential · Exploded View

of pull when extremely low tractive conditions such as ice, mud or snow are encountered at one rear wheel. It also provides smooth transfer of torque when traveling over alternating tractive to non- tractive conditions at either rear wheel.

During application of torque to the axle, the initial spring loading of the clutch packs is supplemented by the gear separating forces between the side and spider gears which progressively increases the resistance in the differential. The unit therefore provides greater resistance under greater torque loads. This is not, however, a positive lock differential and it will release before excessive driving force can be applied to one rear wheel.

CAUTION: *When working on a car with a Positive Traction Differential, never raise one rear wheel and run the engine with the transmission in gear. The driving force to the wheel on the floor may cause the car to move.*

DIVISION III

SERVICE PROCEDURES

40-54 POSITIVE TRACTION DIFFERENTIAL SERVICE PROCEDURES

Overhaul procedures for a Positive Traction Differential are the same as the standard differential except for the internal portion of the case and that the ring gear must be removed.

a. Disassembly

1. Remove differential case and ring gear following the procedures set forth in Section "I" paragraph 40-50.
2. Remove differential case pinion lock screw, lock washer and pinion shaft.
3. Insert a brass drift through observation hole in the case and by tapping on the spring retainers.

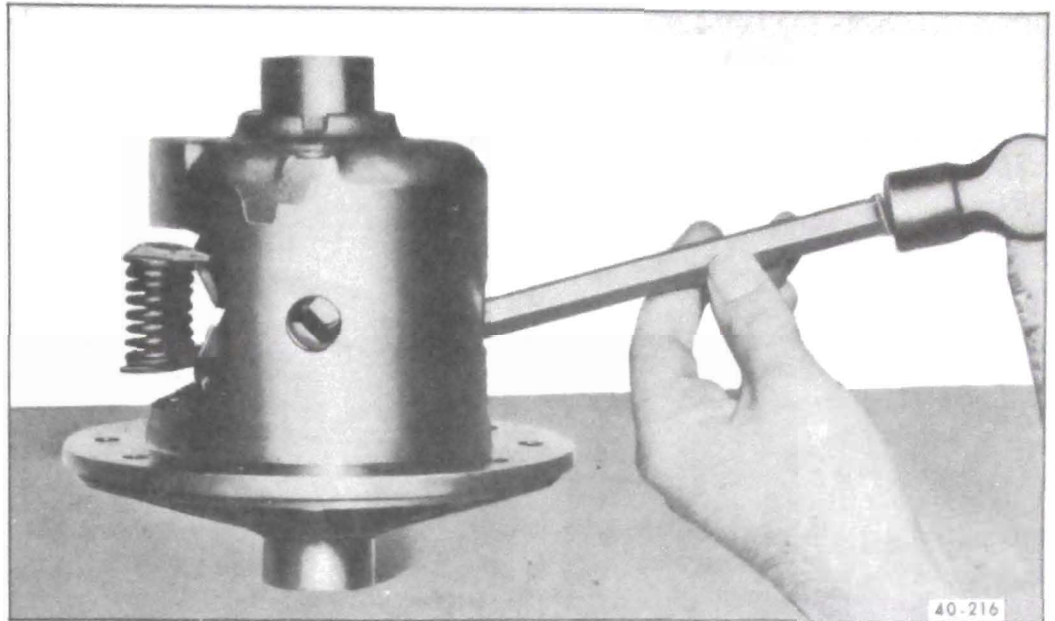

Figure 40-203 - Partial Removal of Preload Springs and Retainers

partially remove the preload springs and retainers. See Figure 40-203.

4. Install 1/4" bolts through retainers and springs and secure each bolt with a nut.

5. Continue to drive spring and retainer assembly from case until retainers are sufficiently exposed to permit installation of bar stock and a "C" clamp over the center of the

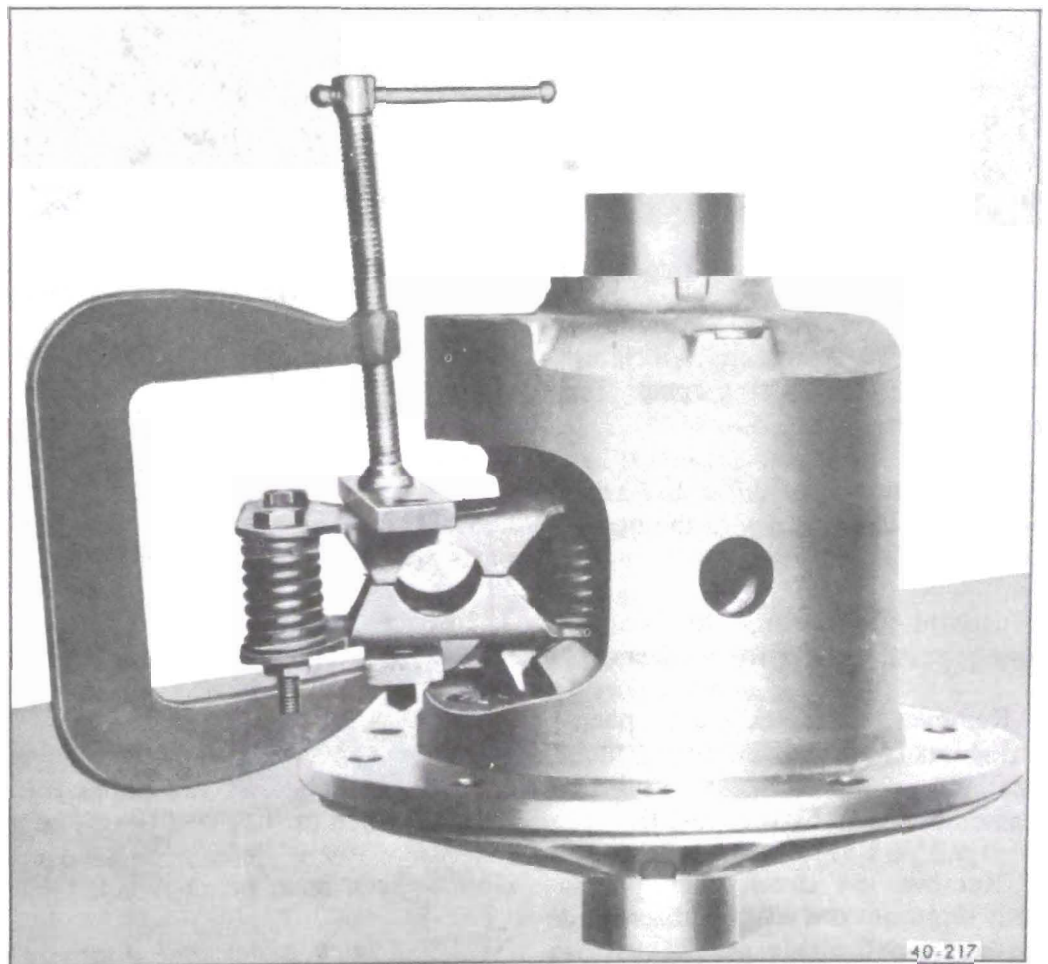

Figure 40-204 - Install 1/4' Bolts, Bar Stock and 'C' Clamp

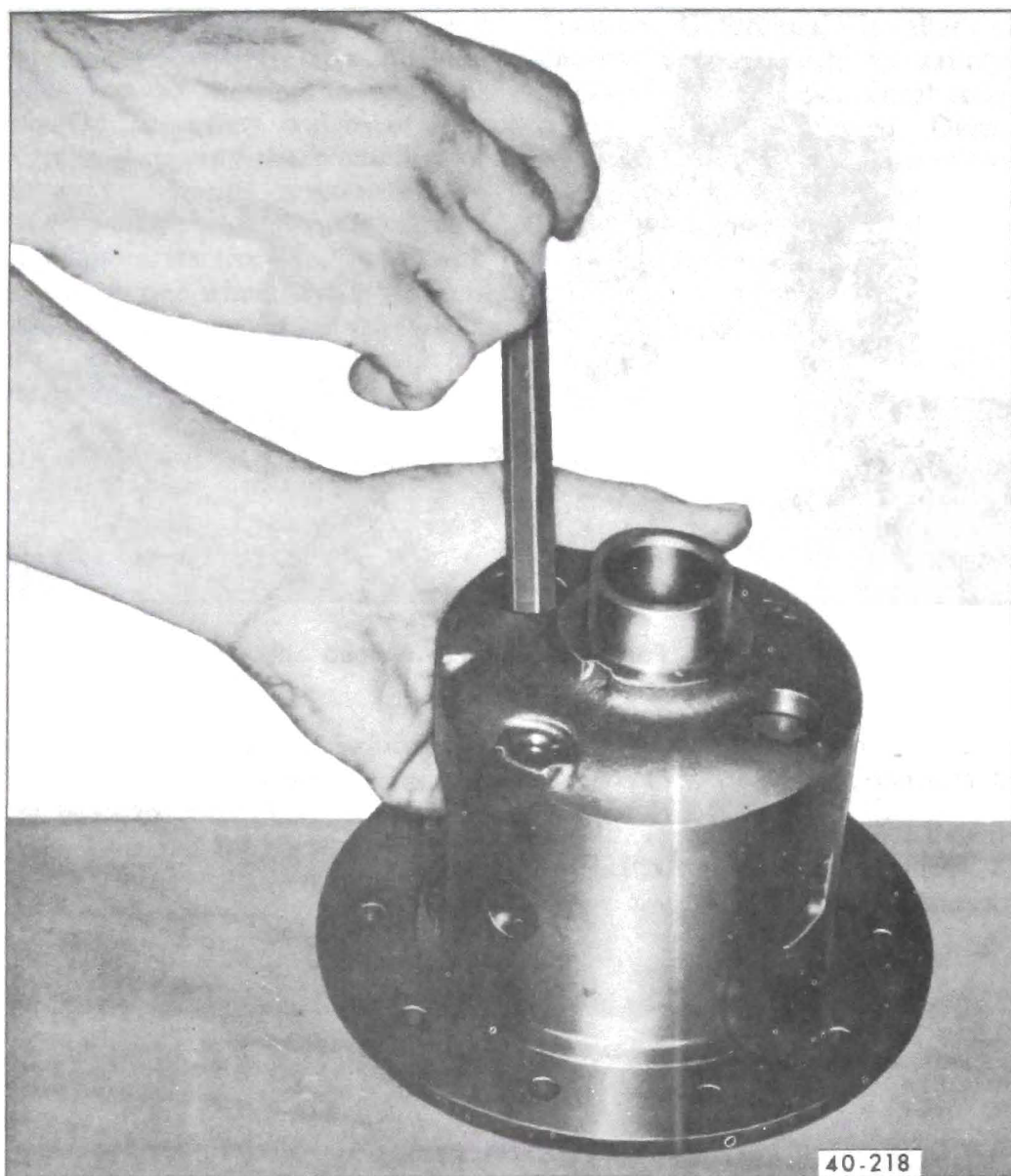

Figure 40-205 - Removing Clutch Pack

axle shaft holes. Tighten "C" clamp to compress the spring pack for removal. See Figure 40-204.

6. The spring pack can be disassembled and reassembled with the use of a vise.

7. Rotate side gears to remove pinion gears and thrust washers.

8. Remove side gears, clutch packs and shims from the case noting their location in the case to aid in reassembly. See Figure 40-205.

9. Remove the clutch pack guides and separate the clutch discs and plates from the side gears.

NOTE: *Keep the clutch plates and*

discs in their original location in the clutch pack.

b. Cleaning and Inspection of Parts

1. Make certain that all differential parts are absolutely clean and dry.

2. Inspect pinion shaft, pinion and side gears. Replace any parts which are excessively scored, pitted or worn.

3. Inspect clutch discs and plates for worn, cracked or distorted condition. If any of these defects exist, new clutch packs must be installed.

NOTE: *Clutch plates and discs are not serviced separately, if replacement is necessary, the clutch pack must be*

replaced as an assembly.

c. Assembly

1. Lubricate clutch plates and discs with special Buick Positive Traction lubricant.

2. Alternately install a clutch plate and a clutch disc on each side gear totalling 5 clutch plates and 4 clutch discs in each clutch pack. See Figure 40-206.

3. Install clutch pack guides on the clutch pack lugs making sure that the clutch disc lugs are engaged in the side gear splines.

4. Select side gear shims of equal thickness to those removed from the case, or if old shims are suitable, reinstall them on the side gear hub.

5. Check the pinion to side gear clearance as follows:

a. Install one side gear, clutch pack and shims in the case.

b. Install both pinion gears, thrust washers, pinion shaft and lock bolt.

c. Compress the clutch pack by inserting a screwdriver or other suitable wedge between the pinion shaft and the side gear. See Figure 40-207.

d. Install dial indicator with the contact button against a pinion gear tooth.

e. Rotate pinion gear back and forth and observe clearance. Pinion to side gear clearance should be within .001" - .006".

f. If clearance is more than .006", increase shim thickness between the clutch pack and case.

If clearance is less than .001", decrease shim thickness. A change in shim thickness of .002" will alter the clearance by approximately .001". If it is necessary to change the shim thickness, recheck the pinion to side gear clearance.

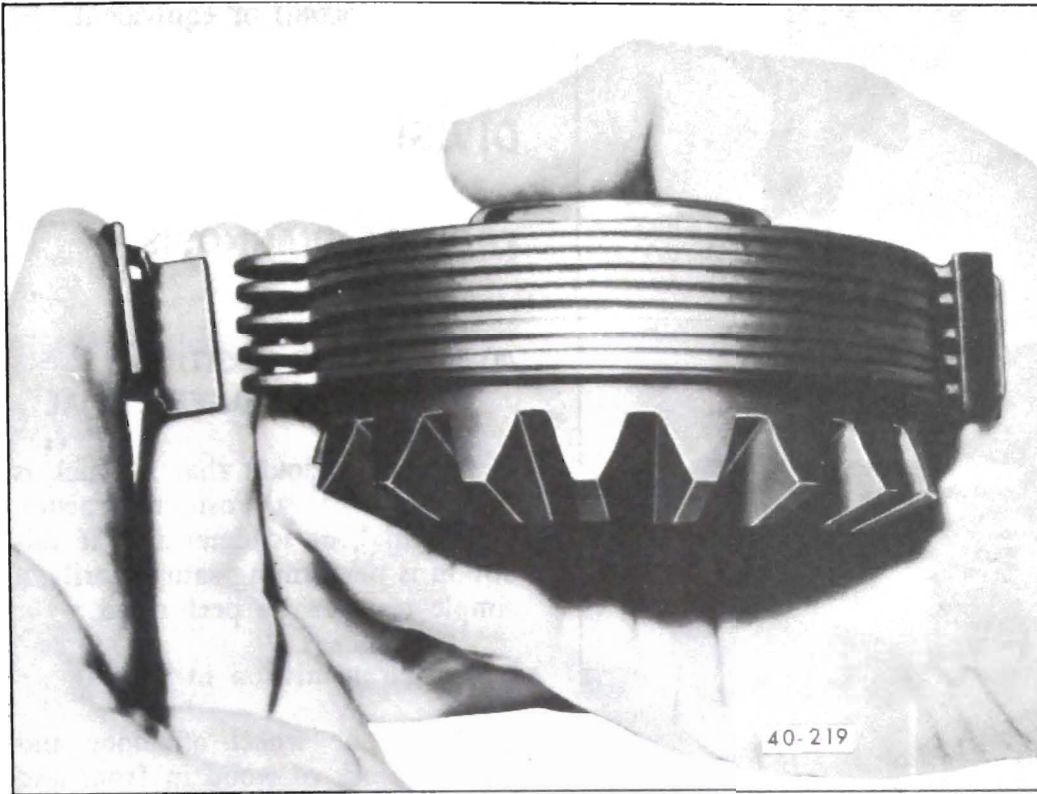

Figure 40-206 - Assembling Clutch Pack

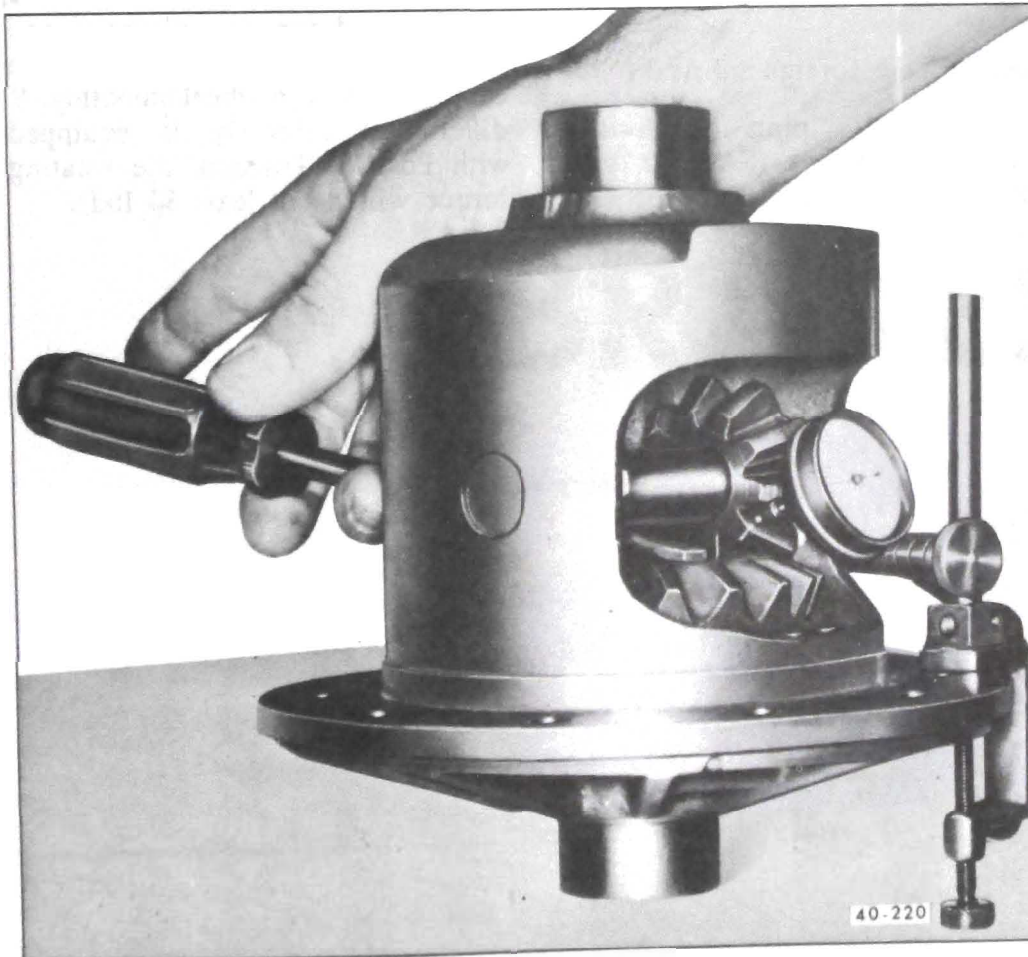

Figure 40-207 - Checking Pinion to Side Gear Clearance

g. Remove this side gear assembly and install the other side gear assembly in the opposite side of case and repeat the preceding procedure.

h. When the correct clearance has been obtained, remove pinion shaft and pinion gears, install the first side gear, clutch pack and shims, reinstall pinion gears with thrust washers and rotate into their operating position.

6. Reassembly preload springs and retainers with the aid of a vise. "C" clamp with bar stock and two 1/4 inch bolts and nuts.

7. Insert spring pack between side gears sufficiently to remove "C" clamp and bar stock.

8. Tap spring pack further into position and remove 1/4 inch bolts and nuts. Then complete the installation. See Figure 40-208.

9. Install ring gear and torque the attaching bolts to 50 lb.ft.

10. Install case assembly into carrier following the procedures in paragraph 40-50, subparagraph (f).

11. Install axle shaft assemblies as outlined in paragraph 40-49, subparagraph (b).

40-55 POSITIVE TRACTION DIFFERENTIAL FLUSHING PROCEDURE

The following procedure is established for flushing the Positive Traction Differential in the event the wrong lubricant is accidentally added.

1. Drain original lubricant from differential housing.

2. Fill axle with a light, non-detergent engine oil.

3. Raise both rear wheels off floor.

4. With car properly supported, run car in "Drive" range for three to four minutes. Do not exceed 30 MPH on speedometer or accelerate or decelerate rapidly.

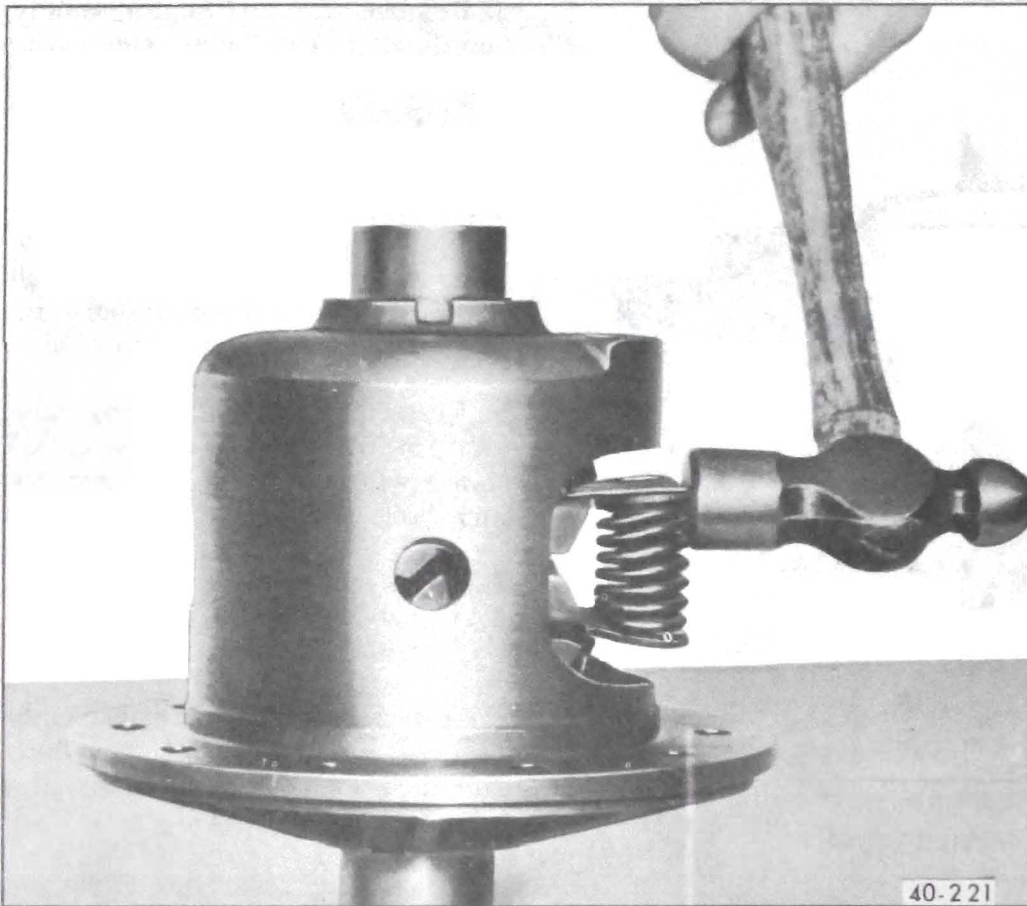

Figure 40-208 - Installing Preload Springs and Retainers

5. Remove oil from axle.
6. Repeat Steps 2, 3, 4 and 5. It is important that the axle be flushed two times to insure complete removal of the foreign lubricant.
7. Install 3-1/2 pints of Positive Traction Lubricant (SAE 90 gear lube meeting specification for GM

Part No. 1050081) or equivalent.

DIVISION IV

TROUBLE DIAGNOSIS

40-56 TESTING POSITIVE TRACTION DIFFERENTIAL

If there is a doubt that a Buick is equipped with a Positive Traction Differential, or to determine if this option is performing satisfactorily, a simple test can be performed.

1. Place transmission in neutral.
2. Raise one wheel off floor and place a block of wood in front and rear of opposite wheel.
3. Remove wheel cover and install torque wrench with extension on lug nut.
4. Disregard breakaway torque and observe only torque required to continuously turn wheel smoothly. If differential assembly is equipped with Positive Traction, the rotating torque will be at least 30 lb.ft.