

# SECTION I

## 43-44000 TYPE "C" DIFFERENTIAL

### CONTENTS

Division	Subject	Paragraph
I	SPECIFICATIONS AND ADJUSTMENTS: Differential Specifications .....	40-47
II	DESCRIPTION AND OPERATION: Description and Operation of the Type "C" Differential .....	40-48
III	SERVICE PROCEDURES: Removal and Installation of Axle Shaft, Bearing and Seal. .... Removal and Installation of Differential Case and Drive Pinion. ....	40-49 40-50
IV	TROUBLE DIAGNOSIS:	

## DIVISION I SPECIFICATIONS AND ADJUSTMENTS

### 40-47 DIFFERENTIAL SPECIFICATIONS

#### a. Tightening Specifications

Use a reliable torque wrench to tighten the parts listed, to insure proper tightening without straining or distorting parts. These specifications are for clean and lightly lubricated threads only; dry or dirty threads produce increased friction which prevents accurate measurement of tightness.

Part	Location	Torque Lb. Ft.
Nut	Rear Universal Joint to Pinion Flange .....	12
Bolt	Differential Pinion Shaft Locking Bolt .....	25
Bolt	Rear Axle Housing Cover to Carrier .....	25
Nut	Brake Assembly to Rear Axle Housing .....	35
Bolt	Ring Gear to Differential Case .....	50
Bolt	Bearing Cap to Carrier .....	55
Nut	Rear Wheel to Axle Shaft .....	65
*Nut	Upper and Lower Control Arm .....	80
*Bolt	Upper and Lower Control Arm .....	110
Nut	Lower End of Shock Absorber to Lower Control Arm Axle Bracket .....	45

\*Torquing of Nut or Bolt to be Optional.

#### b. General Specifications

Rear Axle Type .....	Semi-Floating Hypoid
Drive and Torque .....	Through 4 Arms
Rear Axle Oil Capacity .....	3½ Pints
Ring & Pinion Gear Set Type .....	Hypoid
Differential Lubricant (Standard Axle) .....	MPG SAE 80 or 80-90 (MIL-L-2105-B)

**c. Limits for Fitting and Adjusting**

**Pinion Bearing Preload (Measured at Pinion Flange Nut)**

- New Bearings ..... 20-25 Lb. In. Rotating Torque with New Seal
- Reused Bearings ..... 10-15 Lb. In. Rotating Torque with New Seal

**Total Assembly Bearing Preload (Measured at Pinion Flange Nut)**

- New Bearings ..... 35-40 Lb. Ins.
- Reused Bearings ..... 20-25 Lb. Ins.

Ring Gear Position ..... .005" — .008" Backlash

40I-2

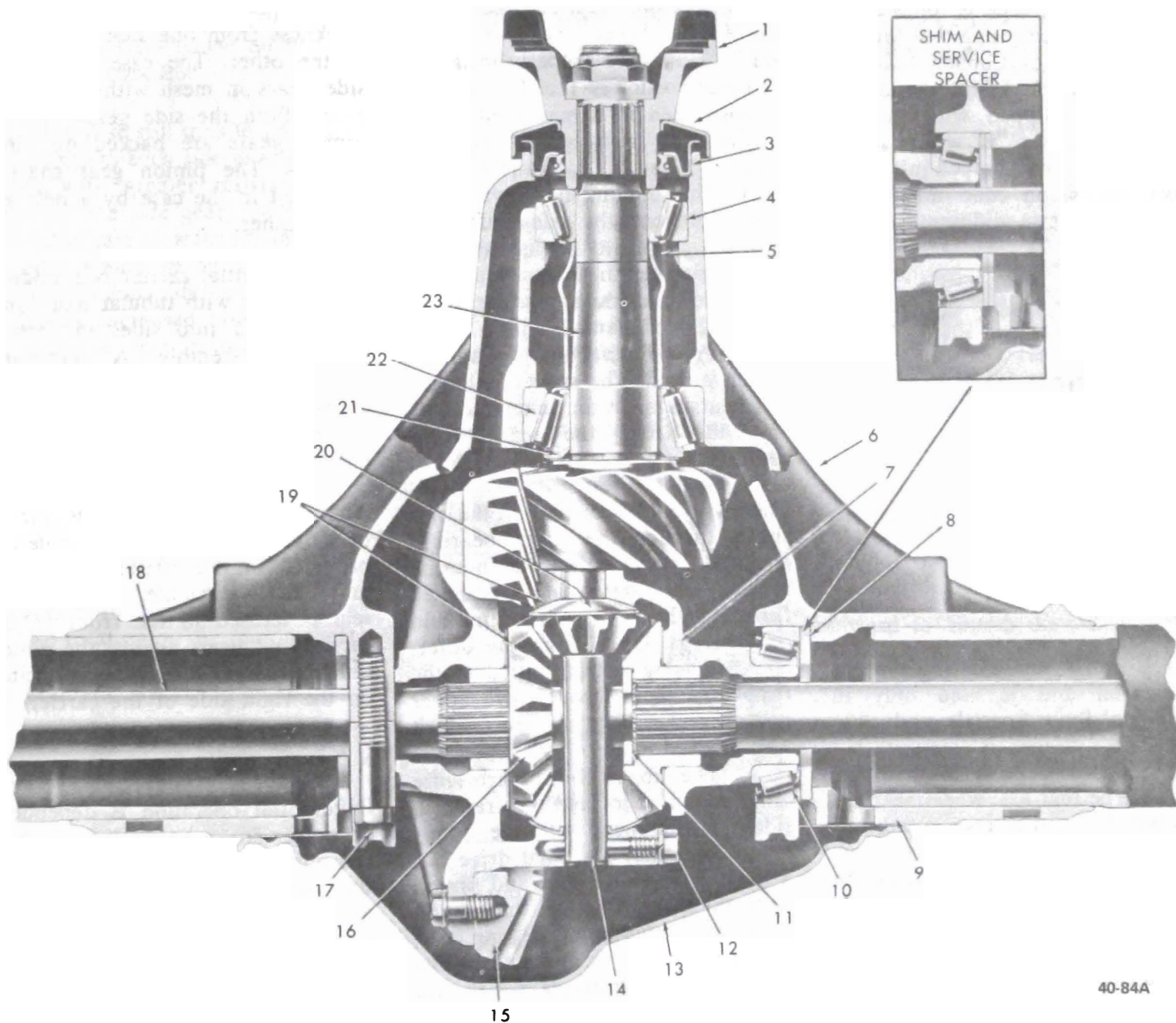

40-84A

- |                          |                            |                  |                         |
|--------------------------|----------------------------|------------------|-------------------------|
| 1. COMPANION FLANGE      | 7. DIFFERENTIAL CASE       | 13. COVER        | 19. THRUST WASHER       |
| 2. DEFLECTOR             | 8. SHIM                    | 14. PINION SHAFT | 20. DIFFERENTIAL PINION |
| 3. PINION OIL SEAL       | 9. GASKET                  | 15. RING GEAR    | 21. SHIM                |
| 4. PINION FRONT BEARING  | 10. DIFFERENTIAL BEARING   | 16. SIDE GEAR    | 22. PINION REAR BEARING |
| 5. PINION BEARING SPACER | 11. "C" LOCK               | 17. BEARING CAP  | 23. DRIVE PINION        |
| 6. DIFFERENTIAL CARRIER  | 12. PINION SHAFT LOCK BOLT | 18. AXLE SHAFT   |                         |

Figure 40-177 · Type 'C' Differential · Cross Section

**d. Differential Gear Ratios**

Gear ratios are indicated by letters stamped on the front face of the right axle tube about 3 inches from the carrier. These letters are followed by a production date code consisting of four digits of which the first two represent the month of the year 01 January, and the last two represent the day of the month. The production date code is followed by the letter "K" indicating that McKinnon Industries of Canada built the assembly. When a differential assembly is equipped with positive traction the letter "E" which stands for Eaton, will be stamped just under the identification code number as well as having a different pair of prefix letters.

AXLE RATIO	STD. AXLE	P.T. AXLE	NUMBER OF PINION TEETH	NUMBER OF RING GEAR TEETH
2.56	LJ	LY	16	41

40-85B

Figure 40-178 - Differential Identification Codes

assembly by means of "C" locks that are positioned in circular grooves machined near the inner end of the axle shafts. When the axle shafts and "C" locks are properly installed, the outer portion of the "C" lock will be positioned in a machined recess in the side gear which prevents removal of the "C" lock and the axle shaft. The pinion shaft, when installed, prevents the axle shaft from moving inward to release the "C" lock. Pinion depth and backlash are calculated in a similar manner to the regular Special and Skylark differential. A different type collapsible spacer is used. The spacer is longer and bears against the inner races of both the front and rear pinion bearings.

The car weight is carried on the axle shafts through the roller bearings enclosed in the outer axle housing tubes. This differential is designed for use with an open drive line and coil springs. Drive from the differential housing is transmitted to the frame members through two upper and two lower control arms which are designed to absorb vibration and noise. The upper control arms are angle mounted to hold the frame in sidewise alignment with the differential assembly. The final drive has a hypoid type ring gear and pinion with the centerline of the pinion below the centerline of the ring gear. The drive pinion is mounted in two tapered roller bearings which are preloaded by the collapsible spacer during assembly. The pinion is positioned by shims located between the drive pinion shoulder and the rear bearing. The pinion and front bearing are held in place by a large pinion nut. The differential case is supported in the carrier by two tapered roller side bearings which are preloaded by inserting shims

between the outer race and the carrier. Ring gear to pinion backlash is changed by varying the shim thickness from one side of the case to the other. The case houses two side gears in mesh with two pinion gears. Both the side gears and the pinion gears are backed by thrust washers. The pinion gear shaft is anchored in the case by a bolt and lock washer.

The differential carrier is a nodular iron casting with tubular axle housings pressed into sides to form a complete assembly. A removable heavy steel cover is bolted to the carrier to permit servicing of the differential without removing the entire assembly from the car.

An oil feed passage to the pinion bearings and an oil return hole are provided in the carrier casting for lubricant to circulate. A pinion oil seal is located in the front of the carrier and bears against the pinion flange. The oil filler plug is located on the right side of the carrier.

**b. Operation**

Differential operation is dependent on power from the engine which is transmitted by way of the transmission and propeller shaft to the drive pinion. As the pinion rotates, power is transferred to the differential case through the ring gear. Since the differential side gears are in mesh with the pinion gears and the pinion gears are held in one position in the differential case by the pinion shaft, power is distributed evenly to each axle shaft providing the road surface resistance to each rear wheel is equal. If the road surface at one rear wheel is soft or slippery it will offer less resistance to spin for that wheel. When this situation occurs the

**DIVISION II****DESCRIPTION AND OPERATION****40-48 DESCRIPTION AND OPERATION OF THE 'C' TYPE DIFFERENTIAL****a. Description**

This is also a semi-floating type of differential and is used only in Canadian Built Specials and Skylarks. Its design is similar but different from regular Buick differentials. The rear axle wheel bearings consist of an outer race, a cage, 15 rollers and two snap rings which retain the cage and rollers in the outer race. The outer race and roller assembly is press fit in the outer end of the rear axle tube at a predetermined depth and is followed by the axle shaft seal. The axle shaft inner splines engage the differential side gears with a floating fit. The shaft has two machined and polished surfaces near the flange end. One of these surfaces is a mating or sealing surface for the axle seal and the other surface is the inner race for the rear axle bearing. The axle shafts are retained in differential

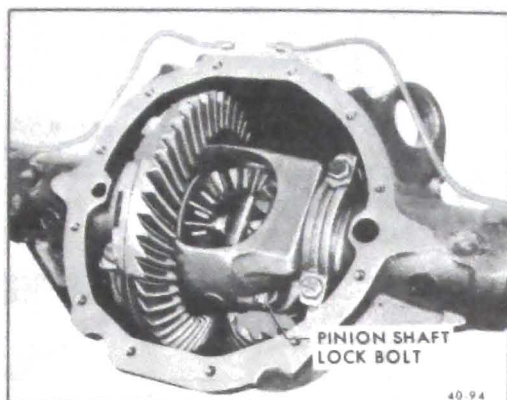

Figure 40-179 - Pinion Shaft Lock Bolt

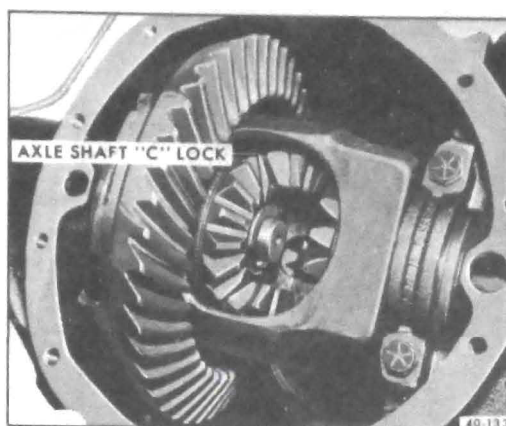

Figure 40-180 - Axle Shaft 'C' Locks

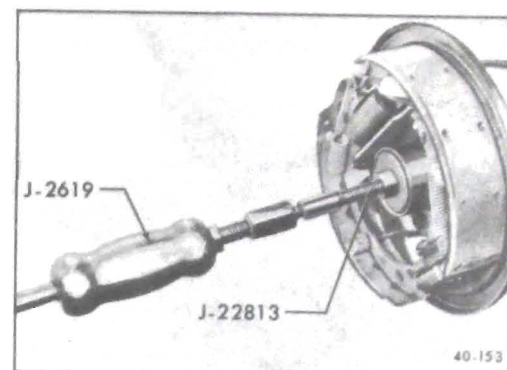

Figure 40-182 - Axle Shaft Bearing and Seal Remover Installed

differential case still tries to transmit equal power to each side gear but in meeting with greater resistance to motion by one side gear, the pinion gears will rotate or walk around this side gear which in turn aids the pinion gears and differential case in distributing increased power to the side gear of less resistance thus causing the one wheel to spin.

The differential acts in the same manner when the car is turning a corner except both wheels are turning. In this case the inside wheel and side gear are rotating slower than the outside wheel and side gear. The pinion gears are at this time revolving with the slower side gear and also rotating on the pinion shaft to increase the speed of the outside side gear and wheel.

## DIVISION III

### SERVICE PROCEDURES

#### 40-49 REMOVAL AND INSTALLATION OF AXLE SHAFT, BEARING AND SEAL

##### a. Removal

1. Raise and suitably support car leaving the rear wheels and differential assembly suspended.
2. Remove rear wheel(s) and brake drum(s).

3. Remove differential carrier cover and allow lubricant to drain.

4. Remove pinion shaft lock bolt and pinion shaft. See Figure 40-179.

5. Push axle shaft(s) inward to permit removal of "C" locks then remove axle shaft(s). See Figure 40-180.

6. Install axle shaft bearing and seal remover J-22813 and remove the bearing and seal. See Figures 40-181 and 182.

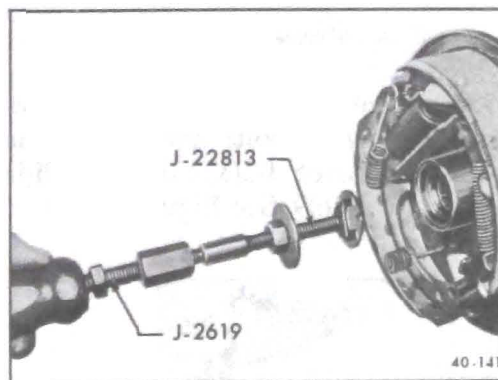

Figure 40-181 - Axle Shaft Bearing and Seal Remover

##### b. Installation

1. Using the axle shaft bearing and seal installer J-21491 install the bearing and then the seal. See Figure 40-183.

2. Insert axle shaft through the seal and bearing and as far as possible through the side gear.

3. Install "C" lock onto axle shaft. Move axle shaft and "C" lock

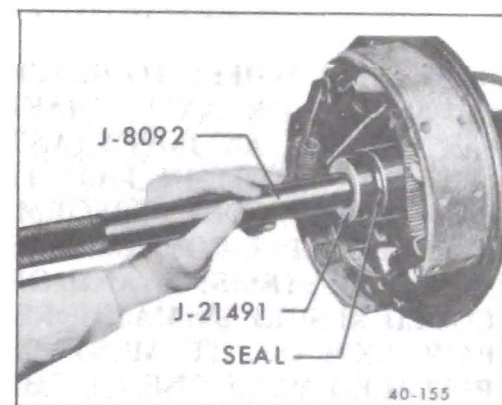

Figure 40-183 - Axle Shaft Bearing and Seal Installer

outward to bottom the "C" lock in the recess of the side gear.

4. Install pinion shaft and secure with lock bolt (25 lb.ft.)

5. Install new gasket and cover, torque bolts to 25 lb.ft.

6. Install 3-1/2 pints of lubricant. Standard Axle - SAE 80, multipurpose gear lube meeting specification MIL-L-2105B. Positive Traction Axle - SAE 90 gear lube meeting specification for GM part 1050081.

7. Install brake drum(s) and wheel(s). Torque wheel nuts to 65 lb.ft.

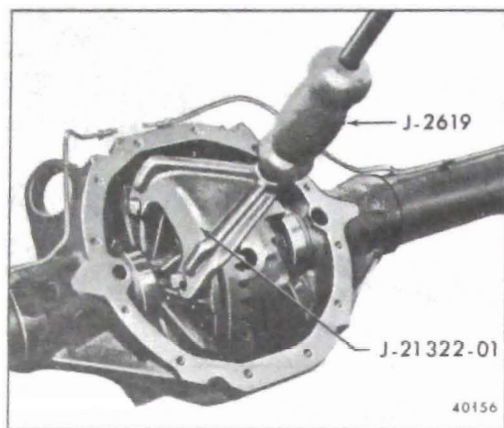

Figure 40-184 - Removing Differential Case From Carrier

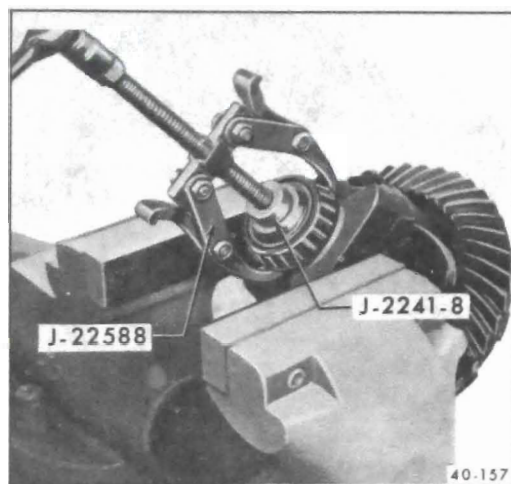

Figure 40-185 - Removing Differential Side Bearings

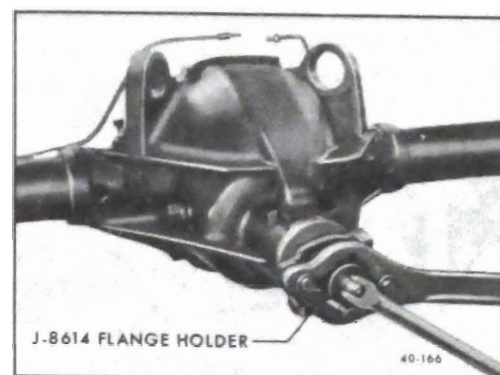

Figure 40-187 - Removing Pinion Nut

**NOTE: THIS WHEEL TO BRAKE DRUM AND/OR AXLE SHAFT FASTENER IS AN IMPORTANT ATTACHING PART IN THAT IT COULD AFFECT THE PERFORMANCE OF VITAL COMPONENTS AND SYSTEMS, AND/OR COULD RESULT IN MAJOR REPAIR EXPENSE. IT MUST BE REPLACED WITH ONE OF THE SAME PART NUMBER OR WITH AN EQUIVALENT PART IF REPLACEMENT BECOMES NECESSARY. DO NOT USE A REPLACEMENT PART OF LESSER QUALITY OR SUBSTITUTE DESIGN. TORQUE VALUES MUST BE USED AS SPECIFIED DURING REASSEMBLY TO ASSURE PROPER RETENTION OF THIS PART.**

3. Mark one bearing cap and the carrier to insure correct position during reassembly.

4. Remove bearing cap bolts and caps.

**CAUTION: Do not pry on bearing caps as the machined face may become damaged.**

5. Remove the two previously loosened ring gear bolts and install the Case Remover J-21322-01 and Slide Hammer J-2619. See Figure 40-184.

6. Remove ring gear and case assembly and place bearing cups and shims with respective bearing cap.

**CAUTION: Do not allow case assembly to drop as this may cause injury or damage parts.**

**b. Disassembly of Case Assembly**

1. Roll out pinion gear and thrust washers and remove the side gears and thrust washers.

2. Position case in vise and remove side bearings using Remover J-22588 and Plug J-2241-8. See Figure 40-185.

3. Loosen and remove ring gear to case attaching bolts and lock washer. Tap ring gear off case using a soft face hammer.

**CAUTION: Do not pry ring gear from case as machined surfaces may become damaged.**

8. Raise the car to remove supports (jack stands) and lower the car.

**40-50 REMOVAL AND INSTALLATION OF DIFFERENTIAL CASE AND DRIVE PINION**

**a. Removal**

1. Remove axle shafts as outlined in paragraph 40-49.

2. Loosen two ring gear to case attaching bolts for assembling ring gear and Case Remover J-21322-01.



Figure 40-186 - Installing Differential Side Bearing

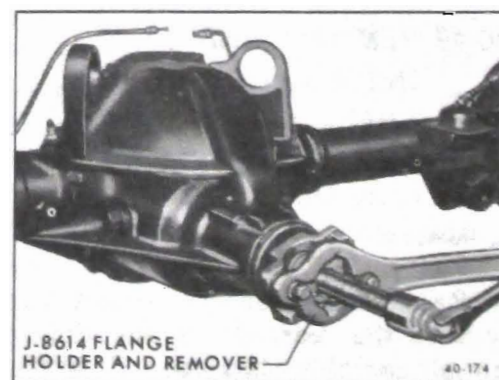

Figure 40-188 - Removing Pinion Flange



Figure 40-189 - Removing Rear Pinion Bearing

**c. Assembly of Differential Case**

1. Install guide pins, made from 3/8"-24x1-1/2" long cap screws with heads cut off and ends slotted, into ring gear.
2. Position ring gear over pilot diameter of case with guide pins aligned in case holes. Install ring gear bolts and lock washer and

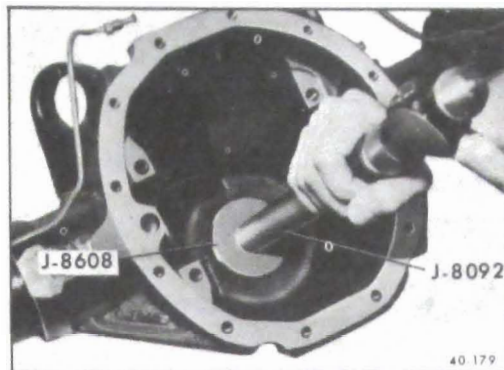

Figure 40-191 - Installing Rear Pinion Bearing Outer Race

tighten evenly and alternately to specifications (50 lb.ft.)

3. Install case side bearings using Installer J-22771 and Drive Handle J-8092. See Figure 40-186
4. Install side gears and respective thrust washers.
5. Install one pinion gear and thrust washer, then rotate with side gears to allow the second pinion gear and thrust washer to be installed 180° from the first. Turn one or both of the side gears until all pinion shaft holes are aligned.

**d. Removal and Disassembly of the Drive Pinion**

1. Install pinion Flange Holder J-8614 to pinion flange and remove pinion nut. See Figure 40-187.
2. Install flange removing portion of Tool J- 8614 and remove pinion flange. See Figure 40-188.
3. By pulling on the gear end of the pinion with one hand and taping the threaded end with a soft faced hammer, remove the pinion and collapsible spacer.
4. Using a screwdriver or other suitable tool remove the pinion seal and front bearing.
5. Remove rear pinion bearing using Remover J-8612 and note the shim used. See Figure 40-189.
6. The front and rear pinion bearing outer races can be removed with the use of a brass drift.

**e. Assembly and Installation of the Drive Pinion**

1. To install the front pinion bearing outer race use Installer J-8611-01 and Drive Handle J-8092. See Figure 40-190.

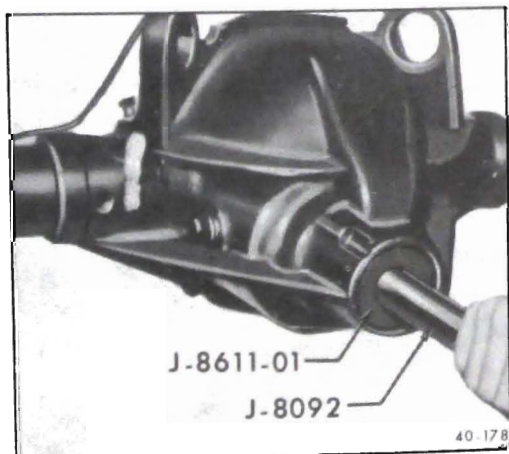

Figure 40-190 - Installing Front Pinion Bearing Outer Race

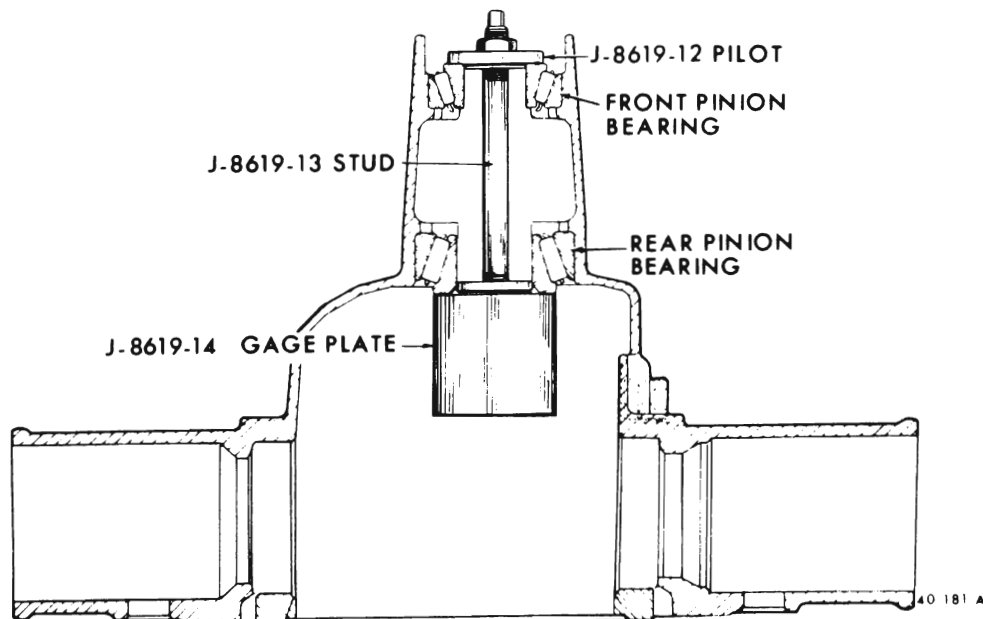

Figure 40-192 - Gage Plate and Bearings Installed

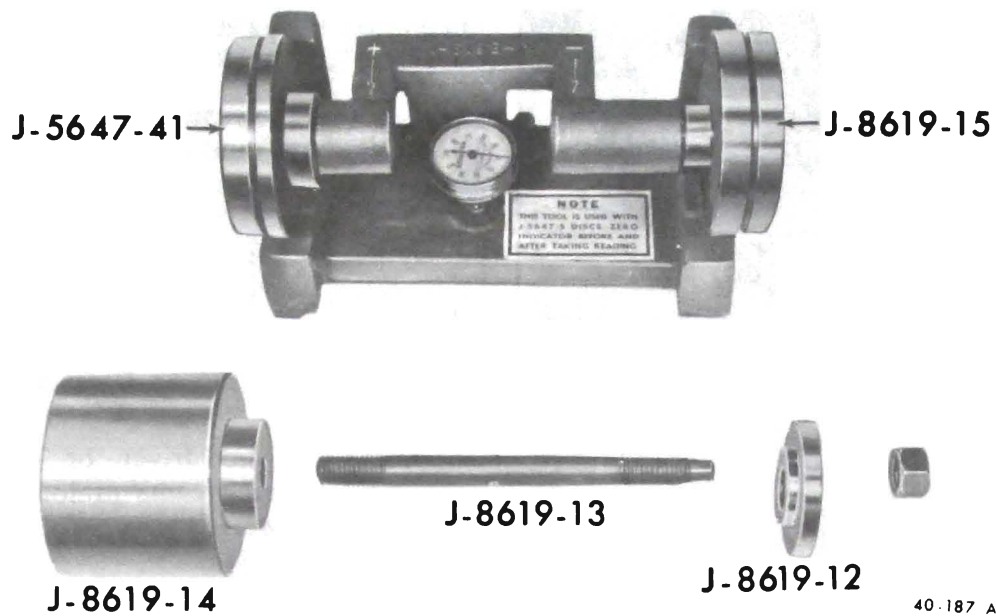

Figure 40-193 - Pinion Setting Gage Assembly

2. To install the rear pinion bearing outer race use Installer J-8608 and Drive Handle J-8092. See Figure 40-191.

3. Assemble pinion bearings, pinion setting Gage Plate J-8619-14, Stud Assembly J-8619-13 and front bearing Pilot J-8619-12 into carrier assembly and tighten hex nut until 20-25 lb.in. (new bearings) or 10-15 lb.in. of torque is required to rotate the bearings. See Figure 40-192.

4. Install dial indicator, with ball-tipped contact button attached on the indicator gage. Install Discs J-8619-15(L) and J-5647-41(R) on indicator gage.

5. Position indicator gage assembly on the master gage so that its spring loaded centering pin is engaged in

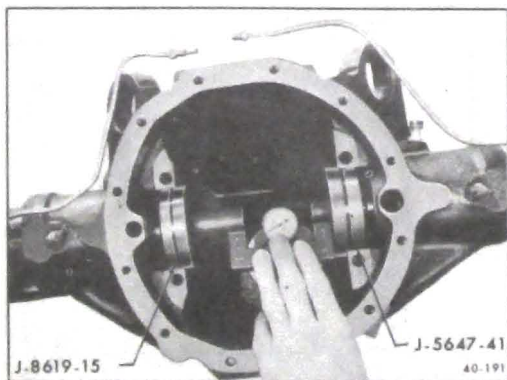

Figure 40-194 - Measuring Pinion Depth

the centering hole in the master gage. See Figure 40-193.

6. Center the dial indicator button on the contact pad and lock the indicator in place by tightening the thumb screw.

7. With the large diameters of the discs contacting both the vertical and horizontal pads of the master gage, press gage yoke down firmly and set dial indicator to zero.

8. After making certain the side bearing bores in the carrier are free of dirt and burrs, install indicator

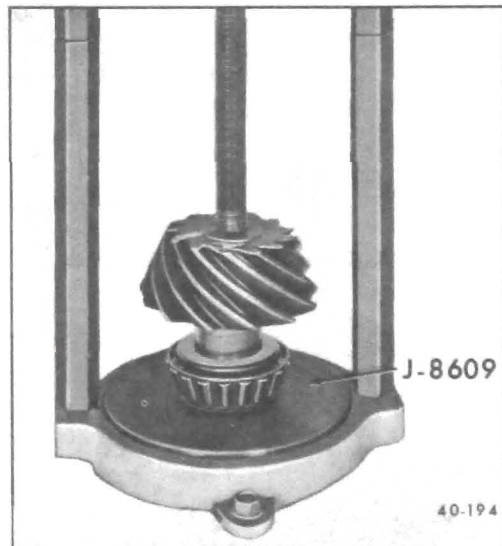

Figure 40-195 - Installing Rear Pinion Bearing

Thick-ness	Identification Notches	
	I.D.	O.D.
.064	0	2
.066	0	3
.068	0	4
.070	1	0
.072	1	1
.074	1	2
.076	1	3
.078	1	4
.080	2	0
.082	2	1
.084	2	2
.086	2	3
.088	2	4
.090	3	0
.092	3	1
.094	3	2
.096	3	3
.098	3	4
.100	4	0

40-240

Figure 40-196 - Shim Chart

gage in carrier with the small diameter of the discs resting in the side bearing bores. The centering pin of the yoke must be located in the centering hole in the gage plate and the ball-tipped contact button of the dial indicator must be positioned against the machined top surface of the gage plate.

9. Press gage yoke down firmly against gage plate and record the number of thousandths registered on the dial. See Figure 40-194. Remove indicator gage and recheck "zero setting" on master gage to insure against error.

**NOTE:** All service drive pinions have a code number 45 stamped on the threaded end of the pinion.

10. Determine the correct thickness

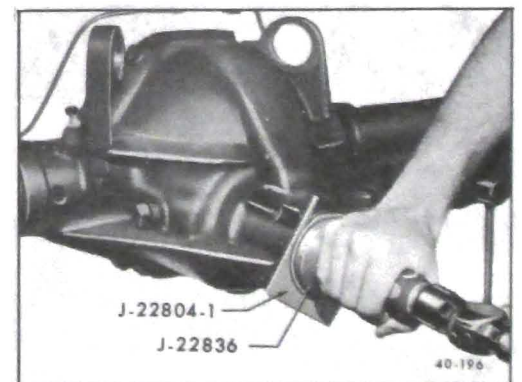

Figure 40-197 - Installing Pinion Oil Seal

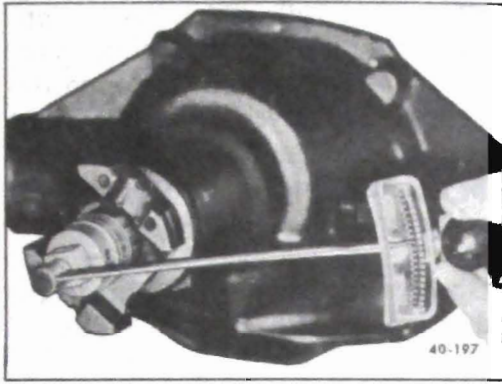

Figure 40-198 - Checking Pinion Preload

of shim required to properly set the pinion by subtracting the figure recorded in step 9 from 100.

**EXAMPLE:**

Base Number 100 Dial Indicator Reading 18 Difference 82 Proper Shim Thickness .082" **NOTE:** Shims are available in .001" increments ranging from .021" to .037". Each shim has its thickness etched on it for easy identification.

11. Install selected shim and rear pinion bearing onto drive pinion using Installer J-8609 and press. See Figure 40-195.

12. Slide a new collapsible spacer on the pinion shaft, position pinion assembly in carrier and install front pinion bearing onto pinion shaft using pinion seal Installer J-22836.

13. Coat cavity between pinion oil seal lips with front wheel bearing grease and install the seal into the carrier bore using Installer J-22836 and Spacer J-22804-1. Rotate spacer occasionally to insure that seal is not slanted in carrier bore. See Figure 40-197.

14. Install pinion flange far enough to come in contact with front pinion bearing, using Flange Holder J-8614 and a suitable wrench, then remove pinion nut and washer.

15. Pack the cavity between the end of the pinion splines and the pinion

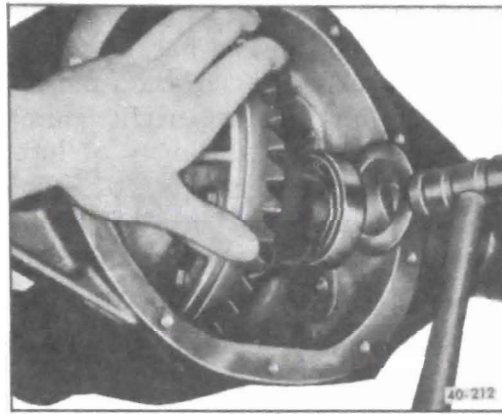

Figure 40-199 - Installing Side Bearing Shims

flange with a nonhardening sealer (such as Permatex type A).

16. Install washer and new self-locking pinion nut on pinion. Tighten nut to remove pinion end play. When end play is removed, alternately tighten nut and check pinion preload until a torque of 20-25 lb.in is required to rotate the pinion with new bearings and seal installed or 10-15 lb.in. when used parts are reinstalled. See Figure 40-198.

**f. Installation of Differential Case Assembly**

Differential side bearing preload is adjusted by changing the thickness of both the right and left shims by an equal amount. By changing the thickness of both shims equally, the original backlash will be maintained. All differential side bearing preload shims used in production are cast. Shims used during service repairs of

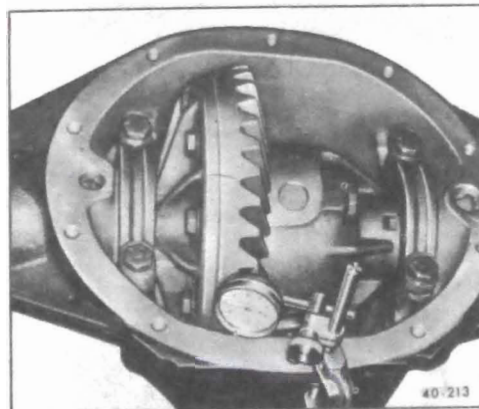

Figure 40-200 - Checking Ring Gear to Pinion Backlash

the differential are of a stamped steel design and are used along with a production type, .160"

or - .001" thick, cast spacer. Stamped steel service shims must be used when differential repairs are made that require removal of the case assembly. Service, steel, adjusting shims are available in thickness ranging from .064" to .100" in increments of .002". See shim identification and availability chart.

1. Before installation of case assembly, make sure that side bearing surfaces in carrier are clean and free of burrs. Side bearings must be oiled with gear lube and if same bearings are being reused, they must have original outer races in place.

2. Place differential case and bearing assembly in position in carrier. Install a service spacer .160" between each bearing outer race and the carrier. Using a micrometer, measure the production cast iron shims initially removed from carrier and record the measurements. Add the thickness difference (in shims) between the service spacer (.160") and the original shim to the respective end of the case between the bearing outer race and the cast service spacer by using a soft faced hammer. See Figure 40-199. Install side bearing caps, as previously marked and tighten bolts to 55 lb.ft. before checking side bearing preload or backlash.

3. Rotate differential case assembly several complete turns to seat bearings. Check bearing preload using an inch pound torque wrench connected at pinion nut. Bearing preload should read 35-40 lb.in. of rotating torque with new bearings or 20-25 lb.in. of rotating torque with reused bearings. See Figure 40-198. If preload is not according to these specifications, increase shim thickness on each side .002" for each additional 10 lb.in. preload desired, or decrease shim thickness .002" on each side for each 10 lb.in. preload to be subtracted.

4. Rotate differential case several



times to seat bearings, then mount dial indicator as shown in Figure 40-200. Use a small button on indicator stem so that contact can be made near heel end of tooth. Set dial indicator so that stem is as nearly as possible in line with gear rotation and perpendicular to tooth angle for accurate backlash reading.

5. With pinion locked to carrier, check gear lash at 3 or 4 points around ring gear. Lash must not vary over .001" around ring gear. If variation is over .001" check for burrs, uneven bolting conditions or distorted case flange and make corrections as necessary.

6. Ring gear to pinion backlash should be in the range of .005" to .008".

If original gear set is being reinstalled, original gear lash should be maintained within + or - .001".

7. If gear backlash is not within specifications, correct by increasing thickness of one differential shim and decreasing thickness of other shim the same amount. In this way, correct differential bearing preload will be maintained.

Shift .002" in shim thickness for each .001" change in backlash desired. If backlash is .002" too much, decrease thickness of right shim .004" and increase thickness of left shim .004". If backlash is .002" too little, increase thickness of right shim .004" and decrease thickness of left shim .004".

8. Check contact pattern with red lead as follows:

a. Wipe oil out of carrier and carefully clean each tooth of ring gear.

b. Mix a small amount of powdered red lead (available from paint manufacturers and suppliers) with a few drops of rear axle lubricant (until the powder is just moist) and apply this mixture sparingly to all ring gear teeth using a medium stiff brush. When properly used, the area of pinion tooth contact will be visible when hand load is applied.

c. Tighten bearing cap bolts to 55 lb.ft. Expand brake shoes until a torque of 40-50 lb.ft. is required to turn the pinion. A test made without loading the gears will not give a satisfactory pattern. Turn pinion flange with wrench so that ring gear

rotates one full revolution, then reverse rotation so that ring gear rotates one revolution in opposite direction. Excessive turning of ring gear may indicate good tooth pattern because one or two teeth are making proper contact.

d. Observe pattern on ring gear teeth and compare with Figure 40-201.

**NOTE:** *The important thing to note is that the contact pattern is centrally located up and down on the face of the ring gear teeth.*

#### g. Axle Shaft Installation

1. Install axle shafts as outlined in paragraph 40-49 subparagraph b.

#### h. Propeller Shaft to Pinion Flange Connection

1. Connect propeller shaft to pinion flange with respect to the alignment marks and torque the four nuts to 12 lb.ft.

## DIVISION IV

### TROUBLE DIAGNOSIS

Refer to paragraph 40-26.

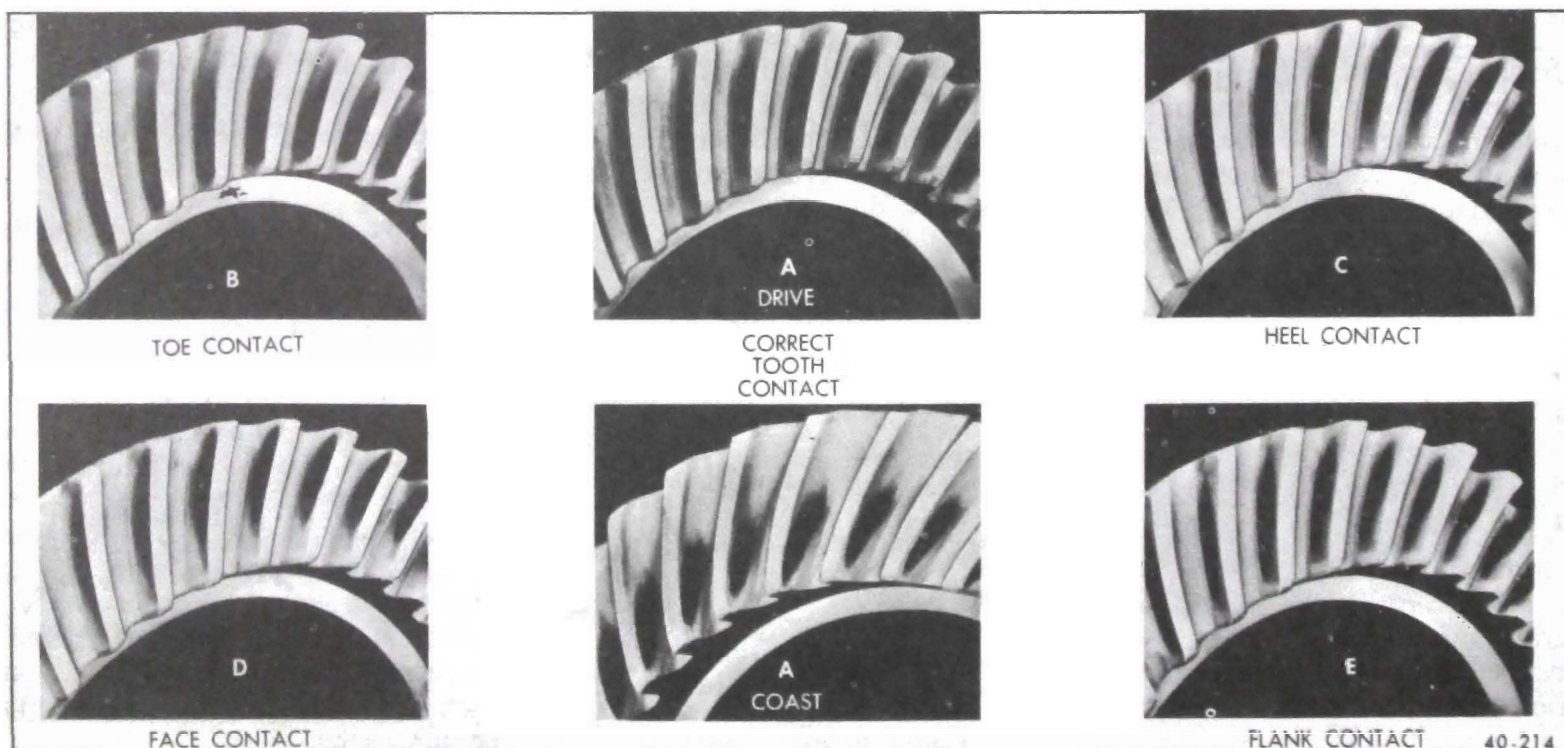

Figure 40-201 - Ring Gear to Pinion Contact Patterns