

SECTION G

46-48-49000 STANDARD DIFFERENTIAL

CONTENTS

Division	Subject	Paragraph
I	SPECIFICATIONS AND ADJUSTMENTS: Differential Specifications	40-33
II	DESCRIPTION AND OPERATION: Description and Operation of Standard Differential	40-34
III	SERVICE PROCEDURES: Removal and Installation of Rear Axle Assembly..... Removal and Installation of Axle Shaft, Wheel Bearing or Oil Seal..... Removal and Disassembly of Differential Case Assembly..... Assembly and Installation of Differential Case Assembly.....	40-35 40-36 40-37 40-38
IV	TROUBLE DIAGNOSIS: Pre-Repair Investigation and Trouble Diagnosis..... Checking Rear Axle Toe and Camber (All Models).....	40-39 40-40

DIVISION I SPECIFICATIONS AND ADJUSTMENTS

40-33 DIFFERENTIAL SPECIFICATIONS

a. Tightening Specifications

Use a reliable torque wrench to tighten the parts listed, to insure proper tightening without straining or distorting parts. These specifications are for clean and lightly lubricated threads only; dry or dirty threads produce increased friction which prevents accurate measurement of tightness.

Part	Location	Thread Size	Torque Lbs. Ft.
Nut	Clamp, Rear U-Joint to Pinion Flange, 46-48000	5/16-18	15
Bolt	Rear CV Joint to Pinion Flange, 49000	7/16-14	85
Bolt	Differential Cover to Housing	5/16-18	30
*Nut	Upper and Lower Control Arm	1/2-13	80
*Bolt	Upper and Lower Control Arm	1/2-13	110
*Nut & Bolt	Upper Control Arm Vernier Adjustment (49000)	7/16-14	48
Nut	Rear Shock, Lower End	1/2-20	65
Bolt	Ring Gear to Case	7/16-20 L.H.	85
Nut	Wheel Bearing Retainer and Brake Assembly to Housing	3/8-24	35
Bolt	Differential Bearing Cap to Housing	7/16-14	53
Nut	Wheel and Brake Drum to Rear Axle Shaft	1/2-20	65
Nut & Bolt	Track Bar to Differential or Frame Bracket, 49000	5/8-18	120

*Torquing of Nut or Bolt to be Optional.

b. General Specifications

Item	All Series (Except as otherwise noted)
Differential Lubricant (Standard Axle)	MPG SAE 80 or 80-90 (MIL-L-2105-B)
Differential Type	Semi-Floating Hypoid
Drive and Torque 46-48000	Through 4 Control Arms
Drive and Torque 49000	Through 3 Control Arms
Differential Oil Capacity	4¼ Pints
Ring and Pinion Gear Set Type	Hypoid
Rear Universal Joint Angle Adjustment, 46-48000	See Section C
Rear Universal Joint Angle Adjustment, 49000	See Section D

c. Limits for Fitting and Adjusting**Pinion Bearing Preload (Measured at pinion flange nut)**

New Bearings	25-30 inch lb. rotating torque with new seal, less ring gear
Reused Bearings	10-15 inch lb. rotating torque with new seal, less ring gear

Total Assembly Preload (Measured at pinion flange nut)

New Bearings	35-40 inch lb. rotating torque with new seal, less ring gear
Reused Bearings	25-30 inch lb. rotating torque with new seal, less ring gear
Ring Gear Position007", .008", .009" Backlash

40G-2

d. Differential Gear Ratio

The gear ratio is indicated by letters stamped on the bottom of the left axle tube. The production date is also indicated by a stamped number which represents the day of the year starting with "1" for January 1. See Figure 40-121.

e. Speedometer Gear

Speedometer gear must correspond to axle ratio and tire size in order to have correct speedometer and odometer reading.

two upper and two lower control arms. Coil springs are seated in brackets which are welded to the axle tubes.

On the 49000 Series, drive from the differential housing is transmitted to the frame through one upper and two lower control arms. The upper control arm is adjustable in length to give the desired universal joint angle. Coil springs are seated in brackets which are welded to the axle tubes.

On all series, large rubber bushings at both ends of the control arms absorb vibration and noise. The final drive is a hypoid type ring gear and pinion with the centerline of the pinion gear below the centerline of the ring gear. See Figures 40-122 and 40-123.

The drive pinion is mounted on two tapered roller bearings which are preloaded by a collapsible spacer during assembly. The pinion is positioned by shims located between the head of the drive pinion and the rear pinion bearing. The front bearing is held in place by a large locking nut. The differential carrier casting has an oil feed passage to the pinion bearings and an oil return hole so that the oil will circulate and cool.

The differential case is supported in the carrier by two tapered roller side bearings. These are preloaded by

inserting shims between the bearings and the pedestals. The differential case assembly is positioned for proper ring gear to pinion backlash by varying these shims. The ring gear is bolted to the case. The case houses two side gears in mesh with two pinion gears mounted on a pinion shaft which is anchored in the case by a roll pin. The pinions and side gears are backed by bronze thrust washers.

The axle shaft inner splines engage the differential side gears with a floating fit. On 46-48-49000 except Estate Wagons, the outer end of the axle shaft is supported in the axle housing by thrust type ball bearings which are factory packed for the life of the bearings and sealed on both sides. The axle shaft oil seals are located inboard of the bearings. On Estate Wagons, the outer end of the axle shaft is supported in the housing by a tapered roller bearing which receives its lubricant from the differential. The axle shaft oil seal is located outboard of the bearing. The bearings are secured against a shoulder on the shaft by a press fit retaining ring. Inward movement of the bearing and shaft assembly is stopped by a shoulder in the housing; outward movement is stopped by a retainer plate. Wheel side thrust is taken at the wheel bearings, so an axle shaft may be removed by removing the nuts holding the bearing retainer and

DIVISION II**DESCRIPTION AND OPERATION****40-34 DESCRIPTION AND OPERATION OF STANDARD DIFFERENTIAL**

The differential assembly is of the semi-floating type in which the car weight is carried on the axle shafts through ball bearings enclosed in the outer axle housing. The differential assembly is designed for use with an open drive line and coil springs.

On the 46 and 48000 Series, drive from the differential housing is transmitted to the frame through

40-76 46-48-49000 STANDARD DIFFERENTIAL

MODELS	ENGINE	TRANSMISSION	AXLE ASSEMBLY RATIO USAGE														
			STANDARD			ECONOMY			PERFORMANCE				SPECIAL CAR ORDER - POSITIVE TRACTION				
			RATIO	REGULAR	CODE	POSITIVE TRACTION	RATIO	REGULAR	CODE	POSITIVE TRACTION	CODE	RATIO	NO. "1"	CODE	RATIO	NO. "2"	CODE
4327-49 4337-49	250 L-4	3-SPEED MANUAL THM 350 WITH AC THM 350	3.23	1917284	LC	1917289	LP					3.42			3.42	1917290	OO
			2.93	1917283	LB	1917288	LW					3.23			3.42	1917290	OO
4327-49 4337-49 4357-49 4407-49-39-49	350 V-8	3-SPEED MANUAL THM 350 2.8BL. THM 350 2.8BL. AC THM 350 4.8BL.	2.93	1917283	LB	1917288	LW										
			2.56	1917284	LK	1917286	LT					3.23					
			2.73	1917282	LL	1917287	LO	2.56	1917281	LK	1917286	LT					
4347	350 V-8	3 & 4-SPEED MANUAL THM 350	3.23	1917284	LC	1917289	LP					3.42			3.64	1917291	OH
3435-76	350 V-8		3.23	1917284	LC	1917289	LP										
			2.93	1917283	LB	1917288	LW	2.73	1917282	LL	1917287	LO	3.23		3.91	1917293	OZ
4407-49	495 V-8	3 & 4-SPEED MANUAL THM 400	3.42	1917285	OH	1917290	OO					3.64					
			2.93	1917283	LB	1917288	LW					3.42			3.64	1917291	OH
4420-39-49 4407-49-45-49	350 V-8	3-SPEED MANUAL THM 350	3.23	1917284	LC	1917289	LP										
			2.93	1917283	LB	1917288	LW	2.73	1917282	LL	1917287	LO	3.23		3.91	1917293	OZ
4407-49	495 V-8	3-SPEED MANUAL THM 400	2.78	1917411	PA	1917412	PT					3.23					
4443-39-49 4407-39-47	495 V-8	3-SPEED MANUAL THM 400	3.07	1917304	PG	1917308	PV	2.78	1917303	PL	1917307	PO	3.23				
4420-39-49 4407-39-47-49	495 V-8	THM 400	2.56	1917302	PB	1917306	PH					3.07		3.91	1917311	PK	3.23
4407			3.07	1917312	PJ	1917314	PH					3.42					
4407-6.5.			3.42			1917315	PY							3.91	1917316	PZ	3.23

FOR FIELD IDENTIFICATION, ALL AXLE ASSEMBLIES TO BE STAMPED WITH LETTERS 3/16" HIGH ON BOTTOM OF AXLE TUBE AS INDICATED FROM CHART. SAMPLE MARKING FOR 3.07 RATIO, DATE: JULY '22, DAY IN THE YEAR 'MFG'D' WOULD BE STANDARD AXLES PG 203, POSITIVE TRACTION AXLES PV 203.

ASSEMBLY PLANT IDENTIFICATION MFG. AXLE CODE LETTERS 1.5 INCHES HIGH STAMPED IN YELLOW INK ON LEFT BRAKE DRUM IN AREA OF WHEEL BOLTS.

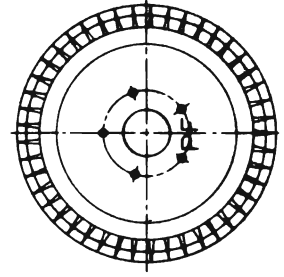
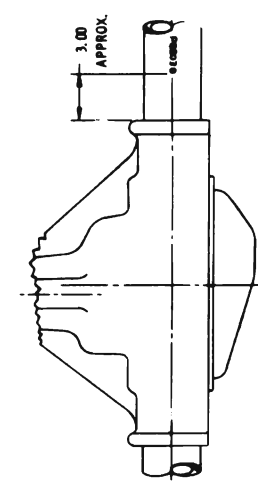

40-120D

Figure 40-121 Differential Identification

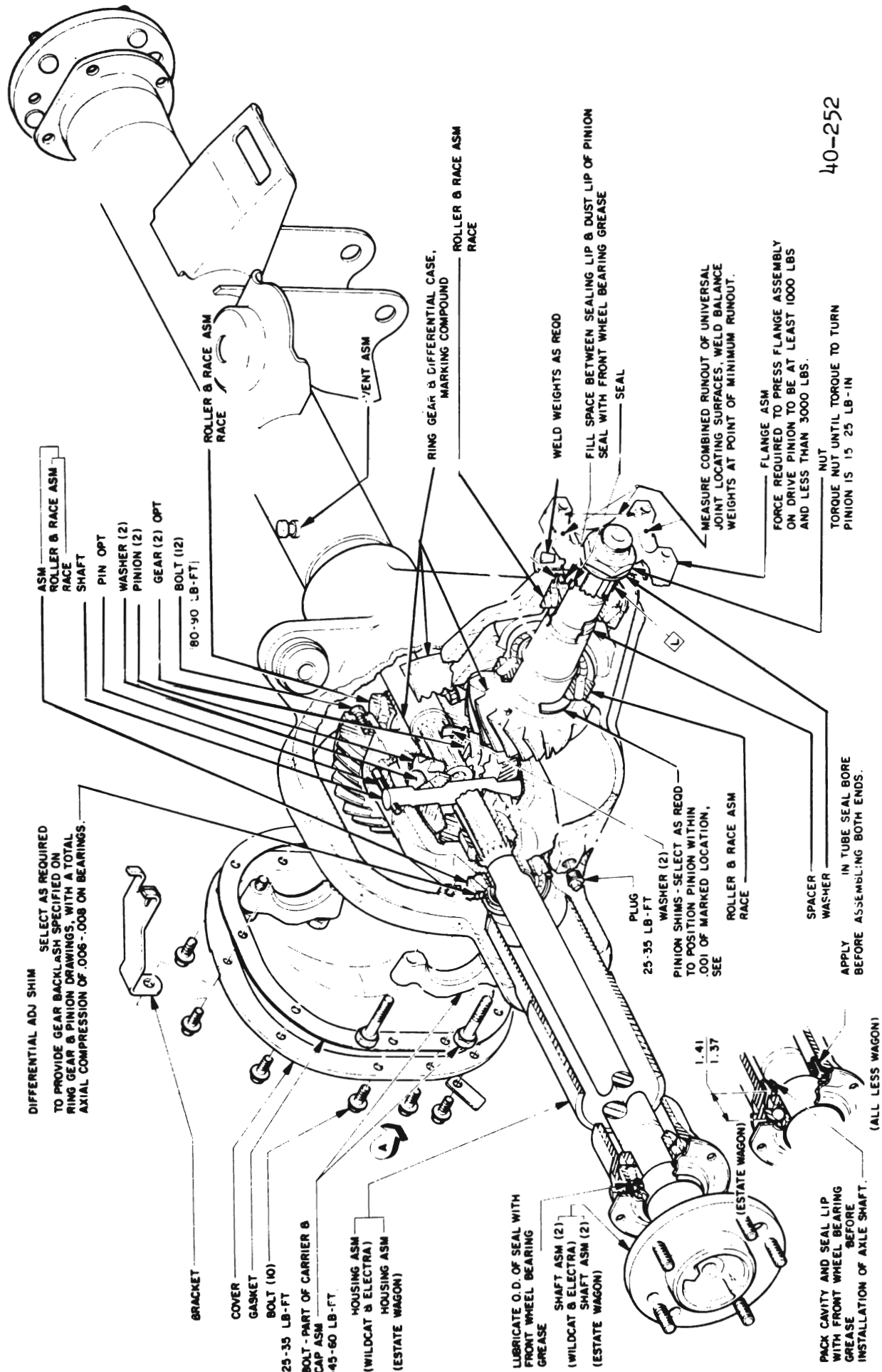

40-252

Figure 40-122 46-48000 Differential Assembly

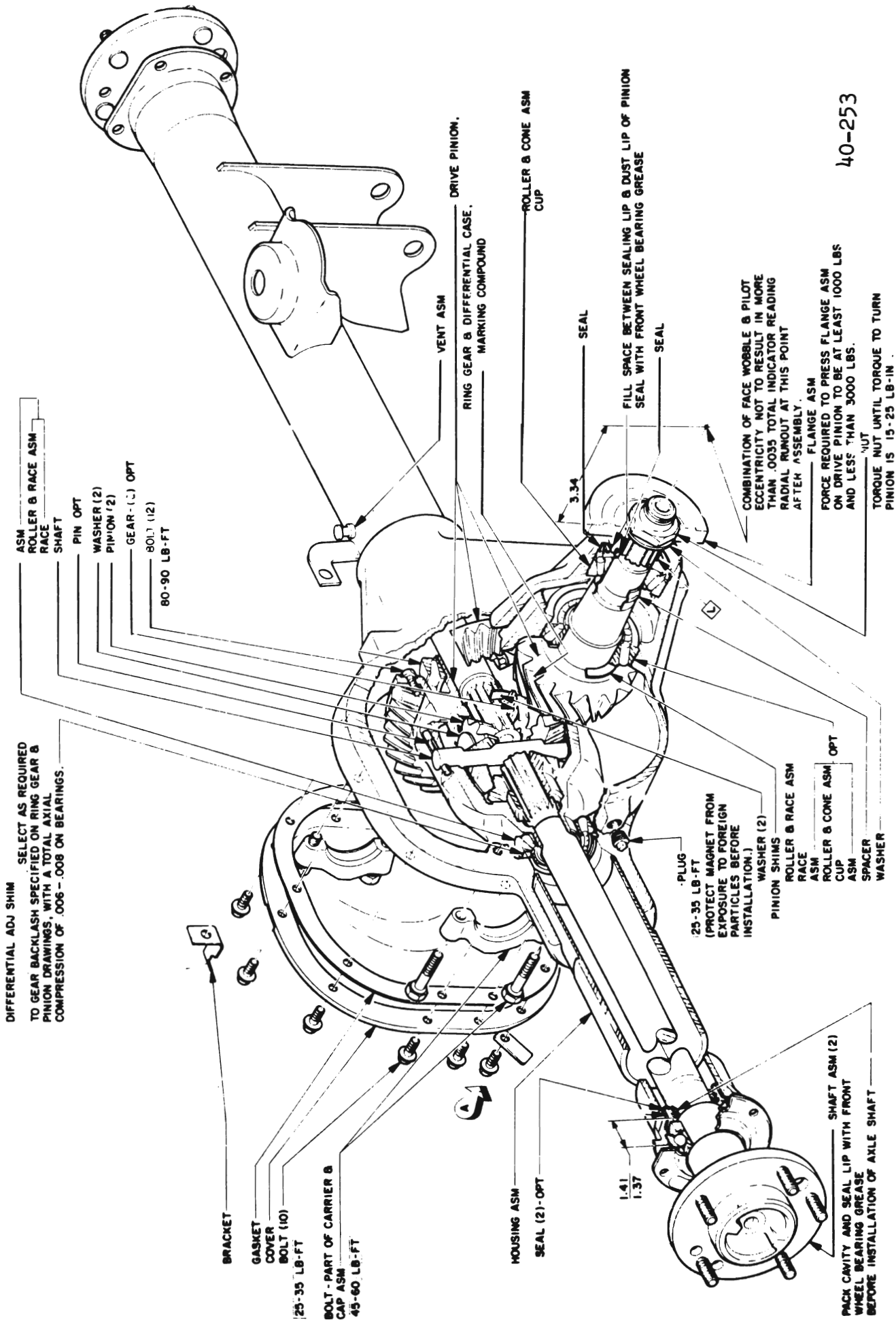

40-253

Figure 40-123 49000 Differential Assembly

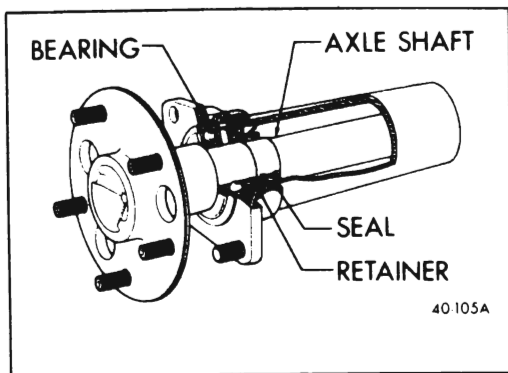

Figure 40-124 Rear Axle Shaft Bearing and Seal for 46-48-49000 Except Estate Wagon

brake backing plate to the axle housing flange. See Figure 40-124.

The rear axle filler plug, which is magnetic, is located in the right side of the carrier casting. The lubricant level is correct when the level is at the filler opening to 1/4 inch below the filler opening. Since periodic lubricant changes are not recommended, there is no drain plug.

The rear brake drum is mounted against the axle shaft flange on bolts pressed through the inboard side of the axle flange. Right and left side wheel bolts both have right hand threads.

A seal in the front of the carrier runs on the pinion flange to prevent differential lubricant from leaking around the O.D. of the flange. An "O" ring seal is compressed between the pinion flange and the drive pinion to prevent lubricant from leaking out through the splines.

DIVISION III

SERVICE PROCEDURES

40-35 REMOVAL AND INSTALLATION OF REAR AXLE ASSEMBLY

It is not necessary to remove the rear axle assembly for any normal repairs. However, if the housing is damaged, the rear axle assembly can

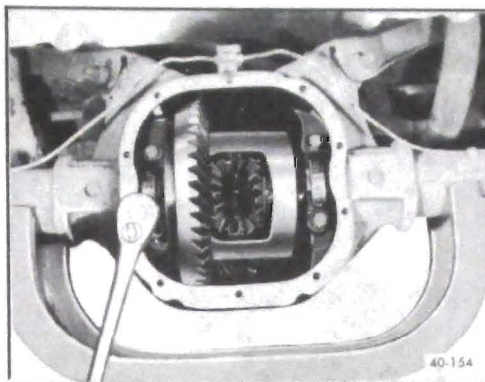

Figure 40-125 Differential in Position for Repair in Car

be removed and installed using the following procedure.

a. Removal of Rear Axle Assembly

1. Raise rear of car and support securely using jack stands under both frame side rails.
2. Mark rear universal joint and pinion flange for proper reassembly. Disconnect rear universal joint by removing two U-bolts. (On 49000, mark flanged ball stud yoke and rear pinion flange for proper alignment as reassembly. Then disconnect rear CV joint from differential by removing four pinion flange bolts.) Push propeller shaft forward as far as possible, then wire it to the upper control arm frame bracket to support it out of the way.
3. Disconnect brake hose at support bracket. Cover hose and brake pipe openings to prevent entrance of dirt.
4. Disconnect parking brake cables. Unclip each cable at two places, disengage from guides, pull each cable free and lay-out forward from rear wheels.
5. Place a jack under center of differential housing and raise until shock absorbers are compressed slightly. Disconnect shock absorbers at lower ends.
6. Disconnect track bar at axle housing on 49000.
7. Disconnect upper control arm (or arms, 46-48000) at axle housing.

8. Lower jack slightly and disconnect lower control arms at axle housing.

9. Lower jack under axle housing and remove.

10. Roll rear axle assembly out from under car.

b. Installation of Rear Axle Assembly

NOTE: Fasteners used on installation of rear axle assembly are important attaching parts in that they could affect the performance of vital components and systems, and/or could result in major repair expense. It must be replaced with one of the same part number or with an equivalent part if replacement becomes necessary. Do not use a replacement part or lesser quality or substitute design. Torque values must be used as specified during reassembly to assure proper retention of this part.

1. Place a jack under center of rear axle housing and raise until aligned with lower control arms. Install lower control arm bolts and nuts. Torque to specified torque.

NOTE: Control arm bushing bolts and shock absorbers to be tightened with suspension in normal load position.

2. Raise jack slightly and connect upper control arms (or arm 49000) to axle housing. Torque to specified torque.

3. Connect track bar to differential housing. Torque nut to 120 lb.ft.

4. Connect shock absorber lower ends. Torque nut to 45 lb.ft.

5. Install parking brake cables through clips and guides and adjust parking brake.

6. Connect brake hose at support bracket and lock in place with clip and bleed both rear wheel cylinders.

7. Connect rear universal joint to pinion flange according to alignment marks. Compress bearings using a

C-clamp so that bearing snap rings will engage pinion flange without gouging. (On 49000, connect flanged ball stud yoke and rear pinion flange according to alignment marks.)

8. Torque U-bolt nuts to 12 lb.ft. using an extension such as J-9113. (On 49000, torque 4 pinion flange bolts to 85 lb.ft.)

9. With car approximately level, fill differential housing to filler plug hole using specified gear lubricant. If differential housing or any rear suspension parts were replaced due to damage, rear universal joint angle must be checked and adjusted as required.

40-36 REMOVAL AND INSTALLATION OF AXLE SHAFT, WHEEL BEARING OR OIL SEAL

a. Remove Axle Shaft Assembly

1. Place jack stands solidly under differential housing so that wheels are clear of floor.

2. Remove rear wheel and brake drum. Both left and right side wheel bolts have right hand threads.

3. Remove nuts holding wheel bearing retainer plate to brake backing plate. Pull retainers clear of bolts and reinstall two opposite nuts finger tight to hold brake backing plate in position.

4. Pull out axle shaft assembly using Puller J-21579 with a slide hammer. See Figure 40-126.

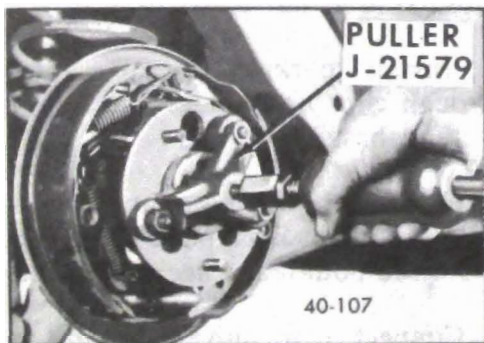

Figure 40-126 Removing Rear Axle Shaft

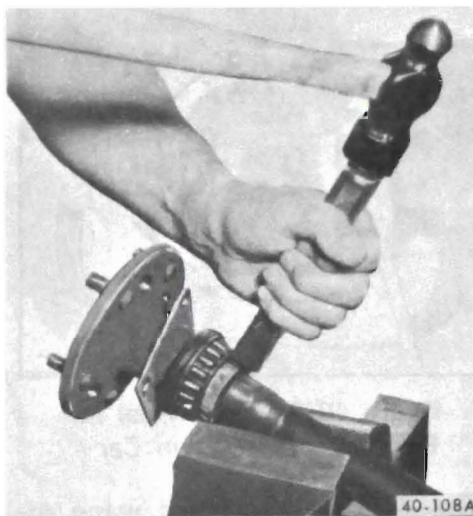

Figure 40-127 Removing Axle Shaft Bearing Retainer (Estate Wagons)

NOTE: While pulling axle shaft out through seal, (46-48-49000 except Estate Wagon) support shaft carefully cutting seal lip.

b. Remove and Install Rear Wheel Bearing

The rear wheel bearing and bearing retainer ring both have a heavy press fit on the axle shaft. Because of this fit, they should be removed or installed separately.

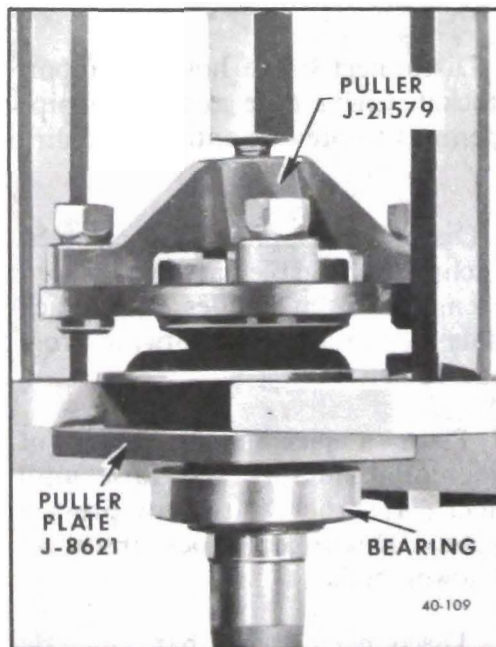

Figure 40-128 Removing Axle Shaft Bearing (46-48-49000 except Estate Wagons)

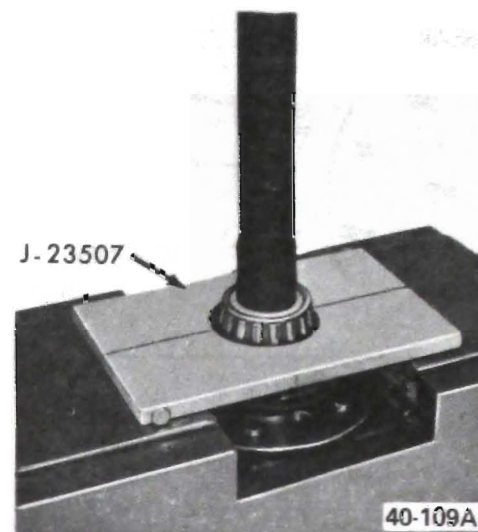

Figure 40-128A Removing Axle Shaft Bearing (Estate Wagon)

Position axle shaft in vise with bearing retainer resting on vise jaws. Use heavy chisel and hammer to split retainer ring. See Figure 40-127.

NOTE: Axle shaft may be nicked if ring is cut completely through.

2. Press axle shaft bearing off, using Puller Plate J-8621 with Remover J-6525 on 46-48-49000 except Estate Wagons or Removal Plate J-23507 for Estate Wagons, either in a press or in a set-up using ram and yoke assembly. See figure 40-128 for 46-48-49000 except Estate Wagons and figure 40-128A for Estate Wagons.

3. Install bearing retainer. Press new and retainer ring against shoulder of axle shaft using Installer J-9739 on 46-48-49000 (except Estate Wagons). See figure 40-129.

4. On Estate Wagons, install seal retainer plate and new seal on axle shaft. Press new bearing and retainer ring on axle shaft using Installer Plate J-6377. See figure 40-129A.

c. Remove and Install Axle Shaft Oil Seal

The oil seal is located inboard of the axle shaft bearing on 46-48-49000 (except Estate Wagons) and outboard of the axle shaft bearing on Estate Wagons with its O.D. tight in

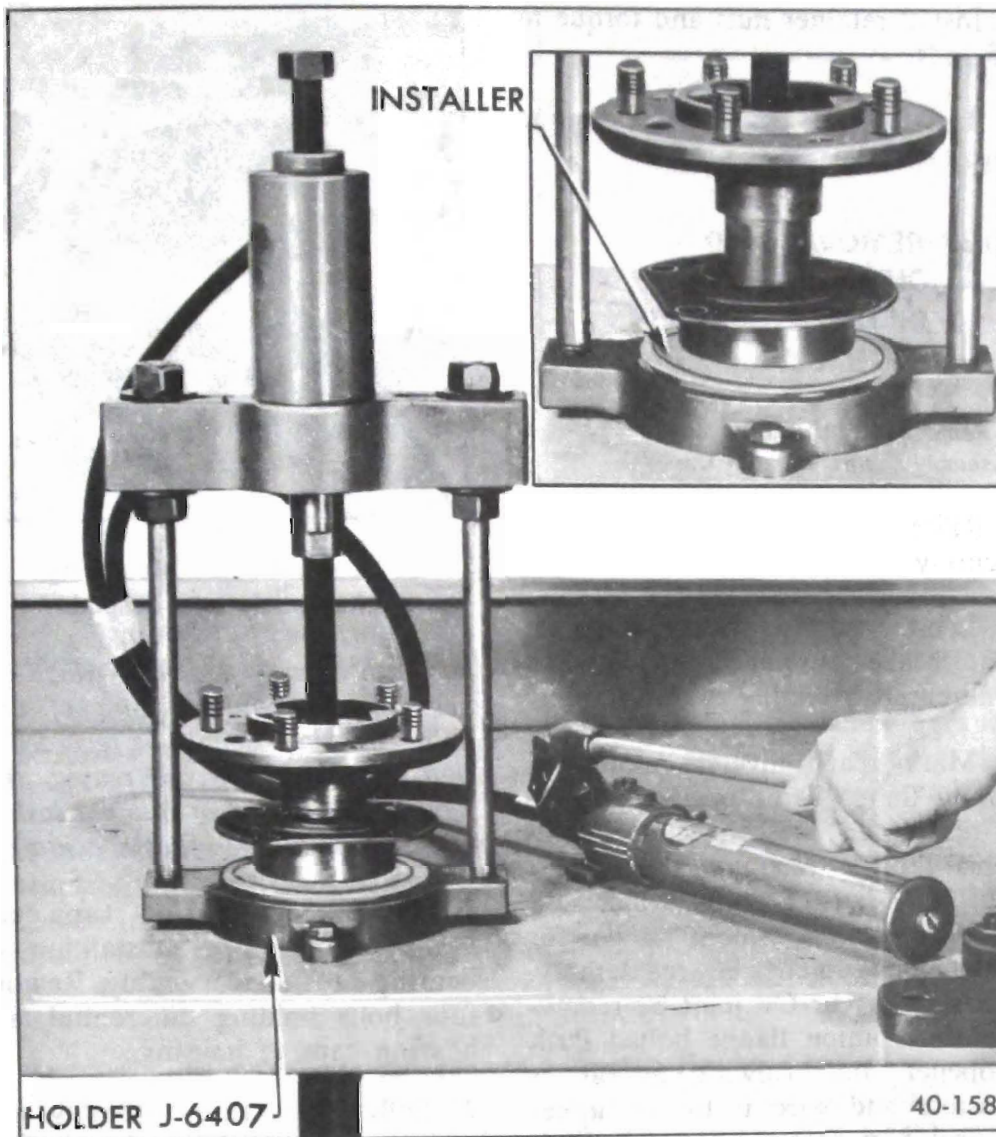

Figure 40-129 Installing Axle Shaft Bearing 46-48-49000 (Except Estate Wagons)

the axle shaft tube and its sealing lip contacting a ground surface on the axle shaft. See figure 40-124. Before removing, install two nuts finger tight to retain backing plate to axle shaft tube. This protects the brake lines.

NOTE: *On Estate Wagons, axle shaft bearing removal and installation procedures must be followed for removal and installation or axle shaft seal.*

1. To remove oil seal, insert Puller J-6199 just through seal and expand. Pull seal with slide hammer. See Figure 40-130.
2. Apply sealer to O.D. of new seal.
3. Position seal over Installer J-22892 and drive seal straight into tube until installer bottoms against wheel bearing shoulder. See Figure 40-131.
4. Pack cavity of seal lip with front wheel bearing grease before installing axle shaft.

d. Remove and Install Rear Wheel Bolt

1. To remove and install a rear wheel bolt, axle shaft assembly must be out of car. Remove rear wheel bolt by pressing from axle flange.

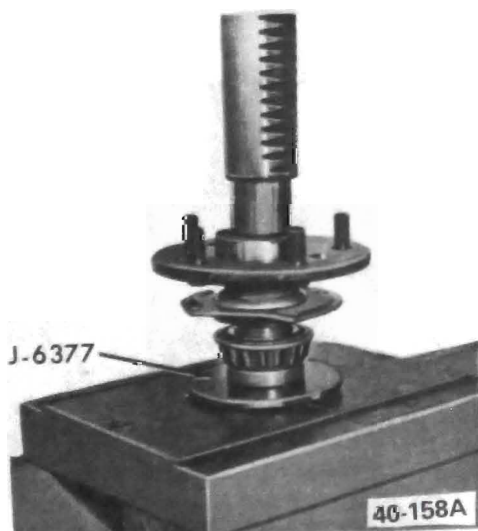

Figure 40-129A Installing Axle Shaft Bearing (Estate Wagons)

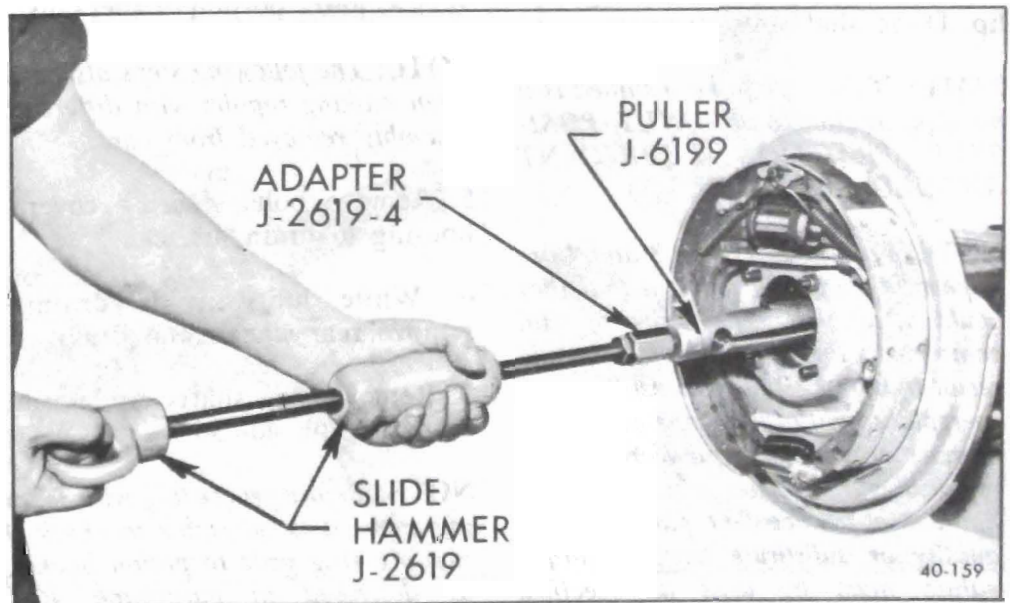

Figure 40-130 Removing Axle Shaft Seal

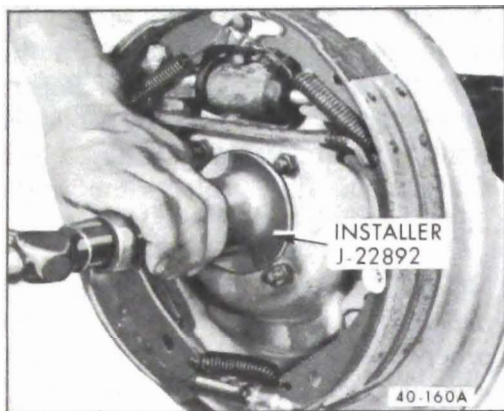

Figure 40-131 Installing Axle Shaft Seal

2. Install new rear wheel bolt by pressing through axle shaft flange. Check new bolt for looseness; if bolt can be moved at all with fingers, axle shaft must be replaced.

e. Install Axle Shaft Assembly

Rear axle shafts are interchangeable between sides.

1. Apply a light coat of wheel bearing grease in wheel bearing recess of housing.

2. Apply gear lubricant to the splines at the inner end of the axle shaft. Apply a coat of wheel bearing grease on the seal surface of the shaft to approximately 6 inches inboard of the shaft. Install axle shaft through seal carefully to avoid cutting seal lip. Drive shaft into position.

NOTE: If the axle to be installed is a positive traction axle, ONLY POSITIVE TRACTION LUBRICANT SHOULD BE USED.

NOTE: Fasteners in steps 3 and 4 are important attaching parts in that they could affect the performance of vital components and systems, and/or could result in major repair expense. It must be replaced with one of the same part number or with an equivalent part if replacement becomes necessary. Do not use a replacement part or lesser quality or substitute design. Torque values must be used as specified during reassembly to assure proper retention of this part.

3. Install retainer nuts and torque to 35 lb.ft.

4. Install drum and wheel. Torque lug nuts to 65 lb.ft.

40-37 REMOVAL AND DISASSEMBLY OF DIFFERENTIAL CASE ASSEMBLY

a. Removal of Differential Case Assembly - Differential in Car

1. Raise rear of car and support securely under rear of frame.

2. Loosen parking brake cable so that brake is not applied when differential assembly is lowered.

3. Mark rear universal joint and pinion flange for proper alignment at reassembly. Disconnect rear universal joint by removing two Ubolts. (On 49000, mark flanged ball stud yoke and rear pinion flange for proper alignment at reassembly. Disconnect rear CV joint by removing four pinion flange bolts.) Push propeller shaft forward as far as possible and wire it to the upper control arm frame bracket to support it out of the way.

4. Disconnect lower ends of both rear shock absorbers and lower differential assembly just far enough to clear lower portion of fuel tank.

NOTE: The following steps also apply when making repairs with differential assembly removed from car.

5. Remove bolts securing cover to housing to drain lubricant.

6. While lubricant is draining, remove rear wheels and drums.

7. Remove axle shafts as described in paragraph 40- 36.

NOTE: Before proceeding with following steps, it is advisable to check the existing ring gear to pinion backlash as described in paragraph 40-38, subparagraph f. This will indicate gear or bearing wear or an error in

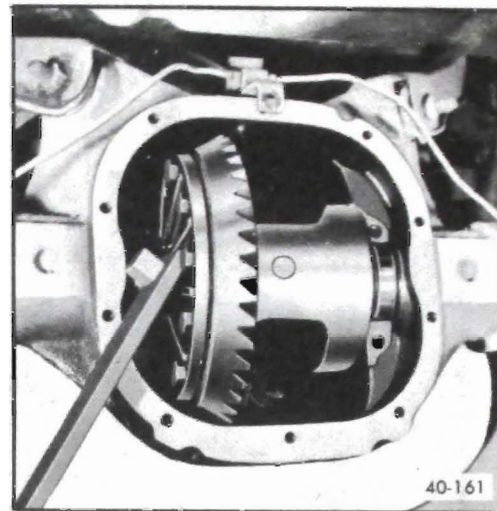

Figure 40-132 - Removing Differential Case Assembly

backlash or preload setting which will help in determining cause of axle noise. Backlash should be recorded so that if same gears are reused, they may be reinstalled at original lash to avoid changing gear tooth contact.

8. Mark side bearing caps and housing for proper installation of bearing caps at reassembly. Remove four bolts holding differential side bearing caps to housing.

9. Differential case assembly can now be removed by prying against ring gear bolt using a suitable pry bar. See Figure 40-132.

CAUTION: Do not allow case assembly to drop as this may cause injury or damage parts.

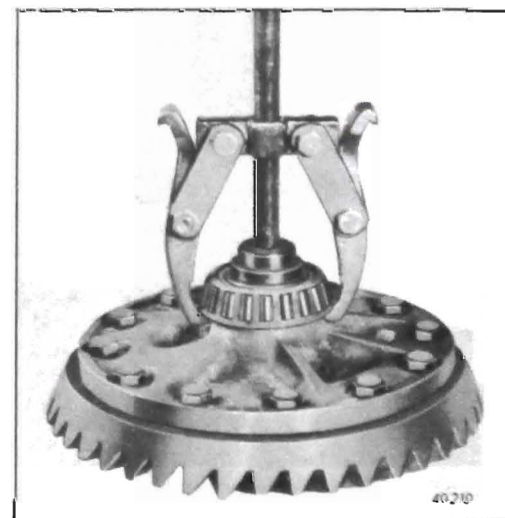

Figure 40-133 Removing Differential Side Bearing

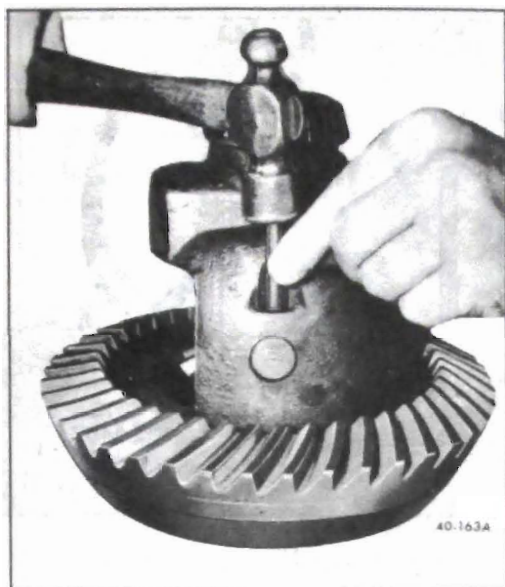

Figure 40-134 Removing Differential Pinion Shaft Pin

b. Disassembly of Differential Case Assembly

1. If differential side bearings are to be replaced, insert Remover Adapter J-2241-8 in center hole and pull bearing using Puller J-22588. See Figure 40-133.

2. Remove pin that retains differential pinion shaft using a suitable punch. See Figure 40-134. Remove differential pinion gears, side gears and thrust washers from case.

3. If ring gear or case is to be replaced and gear is tight on case after removing bolts, tap gear off

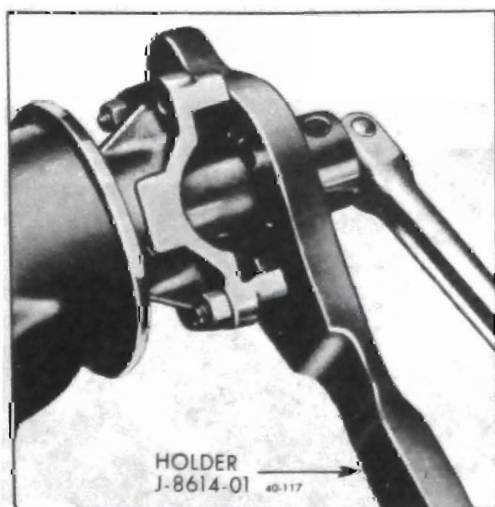

Figure 40-135 46-48000 Removing Pinion Nut

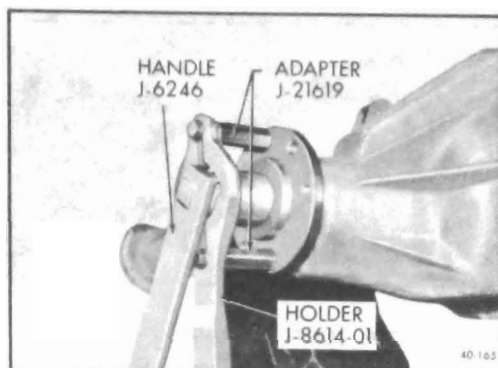

Figure 40-136 49000 Removing Pinion Nut

using a soft hammer; *Do not pry between ring gear and case.*

c. Removal of Pinion and Bearings

1. Check pinion preload as described in paragraph 40-38, subparagraph a. If there is no preload reading, check for looseness of pinion assembly by shaking. Any noticeable looseness indicates worn or defective bearings, requiring replacement. If assembly is run long with very loose bearings, ring gear and pinion will be damaged and also need replacing.

2. Install Holder J-8614-01 on pinion flange using two 5/16-18x2" bolts with flat washers. (On 49000, install Holder J-8614-01 on pinion flange using Adapters J-21619). Remove pinion nut and washer. See Figures 40-135 or 40-136.

NOTE: *Because of differences in castings, it may be necessary to file*

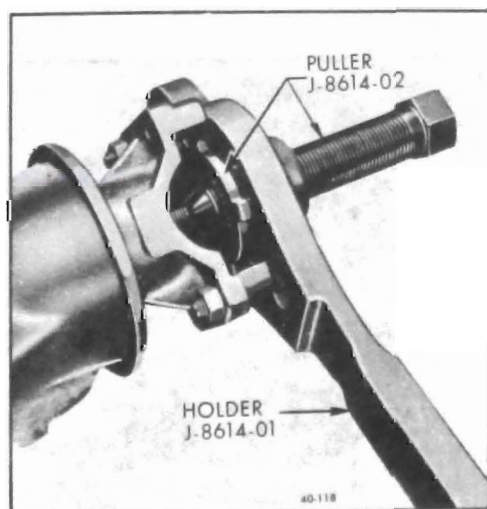

Figure 40-137 46-48000 Removing Pinion Flange

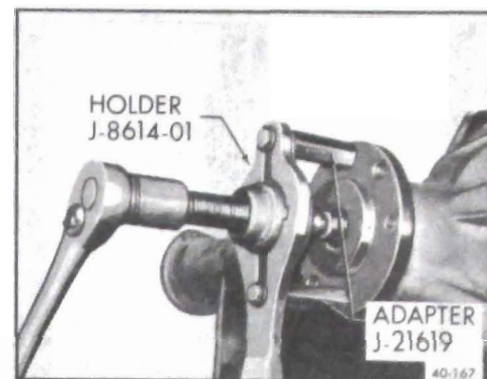

Figure 40-138 49000 Removing Pinion Flange

out slightly the slotted bolt holes in Holder in order to accommodate J-21619 Adapters.

3. Pull flange from pinion using Puller J-8614-02 in Holder J-8614-01. (On 49000 use Puller J-8614-02 in Holder J-8614-01 with Adapters J-21619.) To install puller, back out puller screw, insert puller through holder, and rotate 1/8 turn. See Figures 40-137 or 40-138.

4. As pinion flange is removed, hold hand under pinion to catch it, as it may fall through. Remove "O" ring seal from pinion. If necessary, tap pinion out with a soft hammer.



Figure 40-139 Installing Rear Pinion Bearing Remover

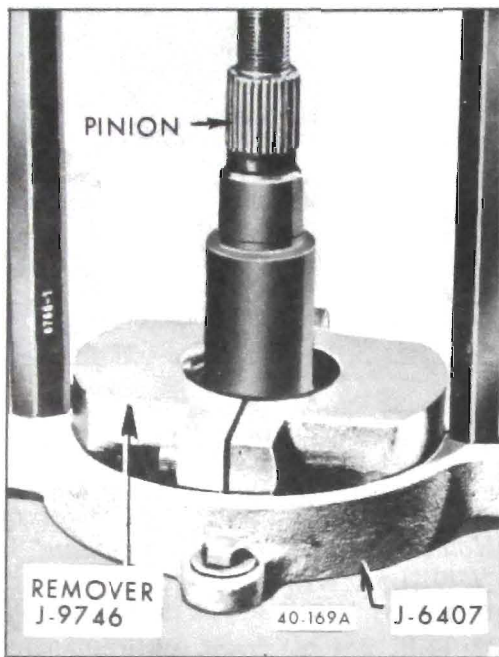

Figure 40-140 Removing Rear Pinion Bearing

being careful to guide pinion with hand to avoid damage to bearing outer races.

5. If pinion or rear pinion bearing is to be replaced, remove rear bearing from pinion shaft using Remover J-9746 and Holder J-6407 in a press or in a set-up using Ram and Yoke Assembly as shown in Figures 40-139 and 40-140.

6. Pry pinion oil seal from carrier, being careful not to damage front pinion bearing outer race. If front pinion bearing is to be replaced, drive outer race from carrier using a drift.

7. If rear pinion bearing is to be replaced, drive outer race from carrier using a drift.

40-38 ASSEMBLY AND INSTALLATION OF DIFFERENTIAL CASE ASSEMBLY

Before installation of any parts, examine the wearing surfaces of all parts for scoring or unusual wear. Make certain that the interior of the carrier housing is absolutely clean and dry. Also make certain that the parts to be assembled are absolutely

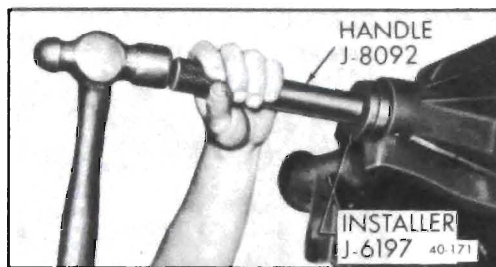

Figure 40-141 Installing Front Pinion Bearing Outer Race

clean and that there are no burred edges. Lubricate all parts with the specified rear axle lubricant just before assembly.

NOTE: *If the Buick is equipped with a Positive Traction Differential, only Positive Traction Lube, G.M. Part No. 1050081 or equivalent should be used.*

NOTE: *If the ring gear and pinion are changed, only factory hypoid lubricant should be used for filling because of its special anti-scoring properties. For this reason the proper lubricant is included in the carton with the replacement gears.*

a. Install Pinion Bearings and Pinion Gear and Adjust Pinion Preload

1. Drive front pinion bearing outer race against shoulder on carrier using Installer J-6197 with driver handle. See Figure 40-141.

2. Drive rear pinion bearing outer race against shoulder in carrier

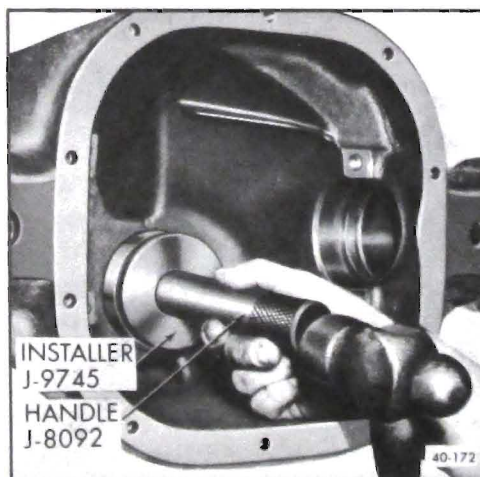

Figure 40-142 Installing Rear Pinion Bearing Outer Race

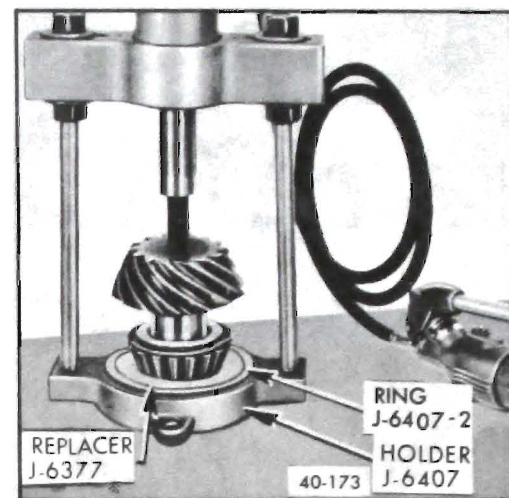

Figure 40-143 Installing Rear Pinion Bearing

using Installer J-9745 with driver handle. See Figure 40-142.

3. Place correct shim (as determined in subpar. b) against head of pinion and install rear pinion bearing using Installer J-6377 and Holder J-6407 with Ring J-6407-2 in a press or as shown in Figure 40-143.

4. Position pinion assembly in carrier and install collapsible spacer as shown in Figure 40-144.

5. Place front pinion bearing in position on pinion. Hold pinion fully forward and lightly drive bearing over pinion until seated. Use Installer J-21005. See Figure 40-145.

6. Install new "O" ring seal on pinion. Coat O.D. of new pinion seal with sealing compound and install seal using Installer J-21005. See Figure 40-146.

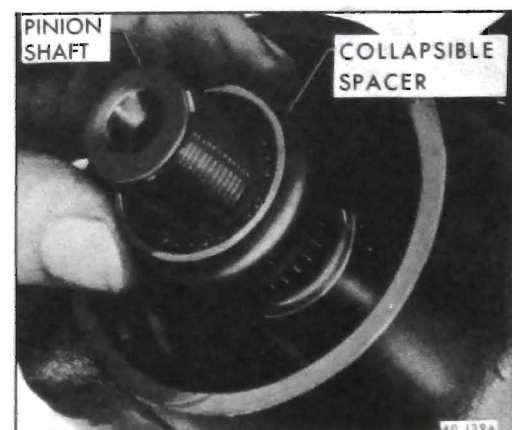

Figure 40-144 Installing Collapsible Spacer

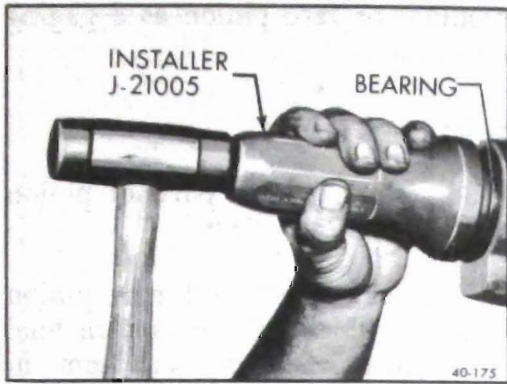

Figure 40-145 Installing Front Pinion Bearing

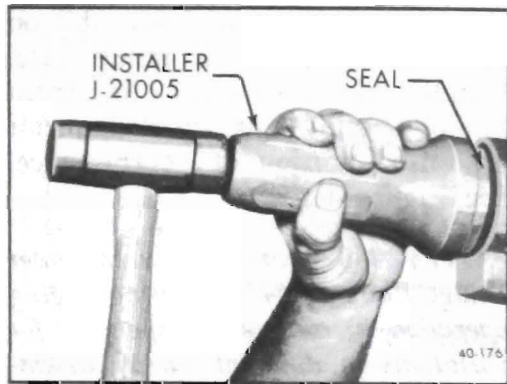

Figure 40-146 Installing Pinion Seal

7. Coat lips of pinion oil seal and seal surface of pinion flange with gear lube. Install pinion flange on pinion by tapping with a soft hammer until a few pinion threads project through flange.

8. Install pinion washer and nut.

Hold pinion flange with Holder J-8614-01. While intermittently rotating

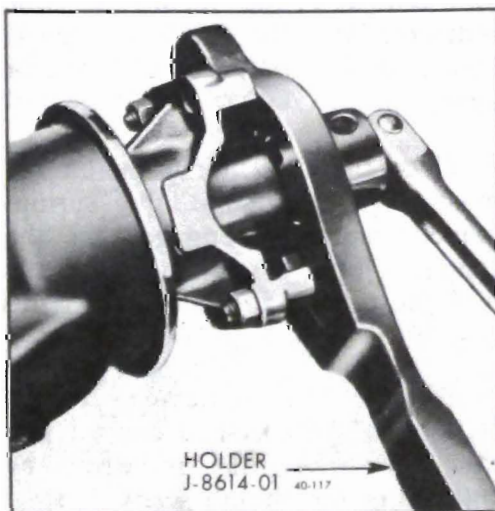

Figure 40-147 Installing Pinion Nut

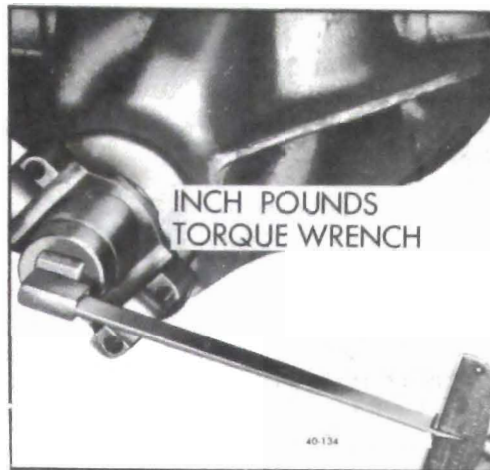

Figure 40-148 Checking Pinion Preload

pinion to seat bearings, tighten pinion nut until end play begins to be taken up. See Figure 40-147.

NOTE: When no further end play is detectable, and when Holder J-8614 will no longer pivot freely as pinion is rotated, preload specifications are being neared. Further tightening should be done only after preload has been checked.

9. Check preload by using an inch pound torque wrench as shown in Figure 40-148.

NOTE: After preload has been checked, final tightening should be done very cautiously. For example, if when checking, preload was found to be 5 inch pounds, additional tightening of the pinion nut as little as 1/8 turn can add 5 additional inch pounds drag. Therefore, the pinion nut should be further tightened only a little at a time and preload should be checked after each slight amount of tightening. Exceeding preload specifications will compress the collapsible spacer too far and require its replacement.

10. While observing the preceding note, carefully set preload drag at 25 to 30 inch pounds on new bearings or 10 to 15 inch pounds on used bearings.

11. Rotate pinion several times to insure that bearings have been seated. Check preload again. If drag has been reduced by rotating pinion, re-set preload to specifications.

NOTE: If new companion flange is installed, the runout of the U-joint surfaces may cause some propeller shaft unbalance. In such a case, refer to Section C or D to correct.

b. Pinion Setting Marks and Setting Gauges

All Buick ring and pinion gear sets are selectively matched for best operating position and proper tooth contact. After matching, a serial number is painted on both the pinion and the ring gear to aid in keeping matched parts together. Parts having different serial numbers must never be used together.

Ring and pinion gear sets are matched in a special test machine which permits adjustment of pinion depth in ring gear until a point is reached where best operation and proper tooth contact under load is obtained. At this point, the setting of the pinion with reference to the centerline of the ring gear is indicated by the machine. This setting may vary slightly from the design or "nominal" setting due to allowable variation in machining the parts. However, most production pinions and all pinions used for service replacement are zero or nominal pinions.

If during repair, a pinion is found having a plus or minus reading recorded in thousandths on the rear face of the pinion, this indicates that the pinion during testing was found to have best tooth contact at a position varying from design or nominal depth.

In order to compensate for all of the allowable machining variables, a procedure of gaging the carrier and shimming the pinion has been developed. After gaging a carrier, the assembler is able to install a shim between the front face of the pinion and its bearing so that pinion depth can be adjusted to an exact required specification for best tooth contact in each axle assembly.

Pinion Setting Gage J-5647 with

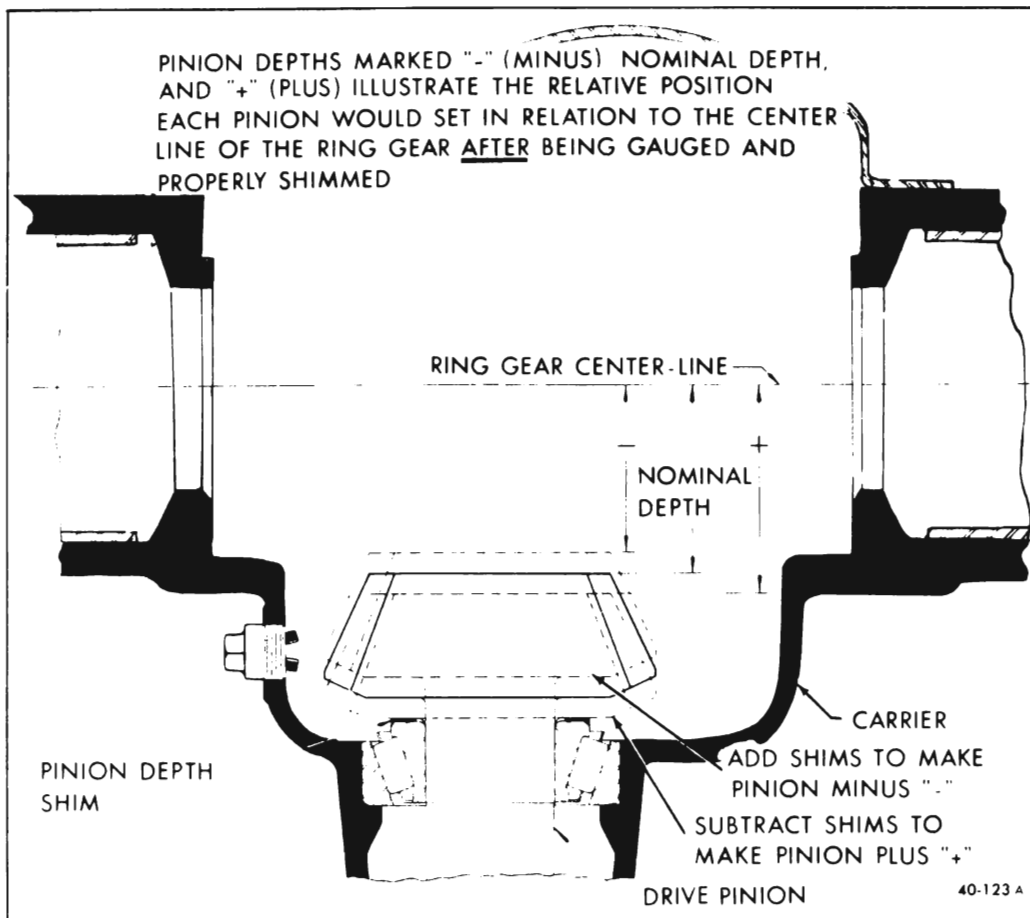

Figure 40-149 Nominal Pinion Setting Depth

Discs J-5647-41 and 42, Pilot J-5647-37, Gage Plate J-5647-36, and Stud and Nut Assembly J-8619-13 is used to set pinion depth. See Figure 40-150.

It is not necessary to reassemble and install the pinion depth shim since the pinion depth setting gage arrangement provides in effect, a

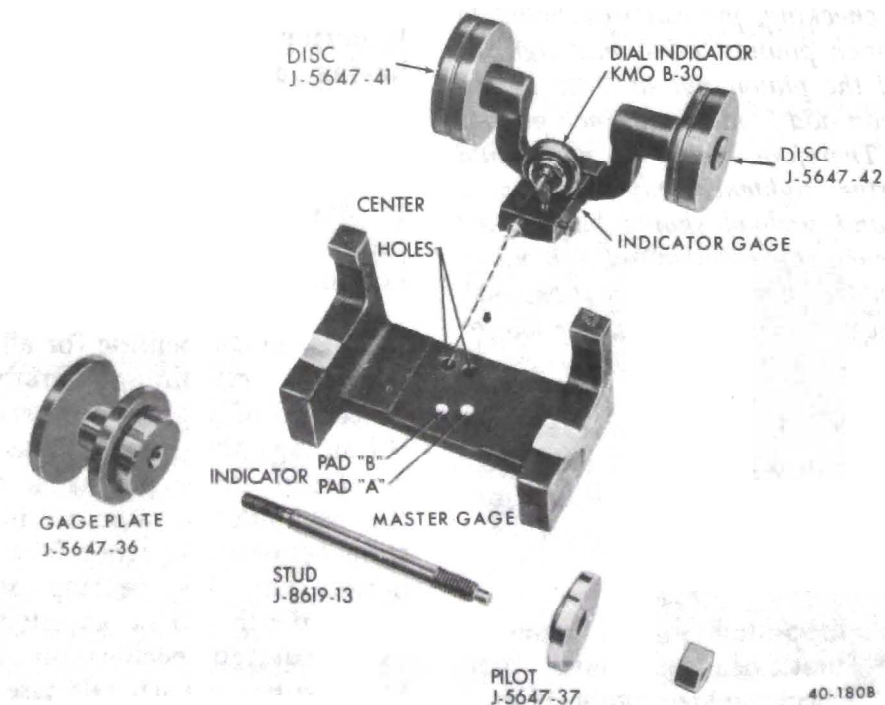

Figure 40-150 Pinion Setting Gage

nominal or zero pinion as a gaging reference.

c. Set Pinion Depth

1. Be certain that all parts of pinion setting gage are clean.

2. Lubricate front and rear pinion bearings which will be used in final reassembly and position them in their respective races in the carrier. Thread Stud J-8619-13 into Gage Plate J-5647-36. With bearings held in place in races, install a 0.50" shim and gage plate and stud assembly on rear pinion bearing inner race. Install Pilot J-5647-37 on front pinion bearing with small diameter on raised portion of bearing race. See Figure 40-151.

NOTE: .050" shim is required under Gauge Plate J-5647-36 during gaging operation in order to compensate for variations in different carrier assemblies. By using .050" shim, the dial indicator will contact Gage Plate J-5647-36 in any carrier assembly during gaging operation.

3. Install nut on Stud J-8619-13. Hold stud stationary with wrench positioned on flats on end of stud; tighten nut until a reading of 20 inch pounds is obtained when rotating the gage plate assembly with an inch pound torque wrench.

4. Install the small ball tipped contact button on the stem of the dial indicator and mount the dial indicator on the indicator gage. Install the discs on the indicator gage.

5. Place the indicator gage on the master gage so that the spring-loaded center is engaged in the centering hold corresponding to the dial indicator pad "B". See Figure 40-152.

6. Center the indicator contact button on the specified contact pad and lock the dial indicator by tightening the thumb screw.

7. With large diameter of Disc J-5647-41 and small diameter of Disc

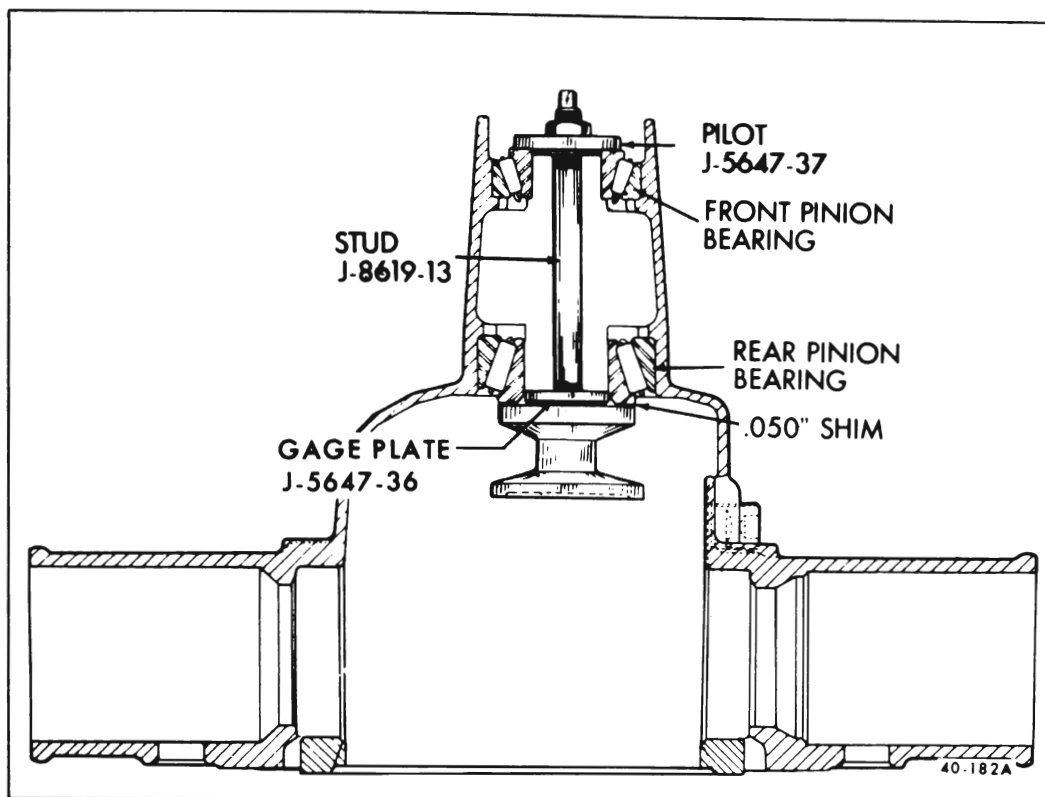

Figure 40-151 Installing Gage Plate In Carrier

J-5647-42 contacting both the horizontal and vertical surfaces on the master gage, hold gage yoke down firmly with thumbs placed on indicator gage between arrow heads and unmachined portion of round disc support legs. Set dial indicator at zero.

8. Be certain that differential bearing support bores are free of dirt and burrs. Place indicator gage in carrier so that small diameter of Disc J-5647-41 and large diameter of Disc J-5647-42 rest in differential bearing pedestal support bores. Hold indicator gage as shown in Figure 40-153. Spring-loaded center of gage must

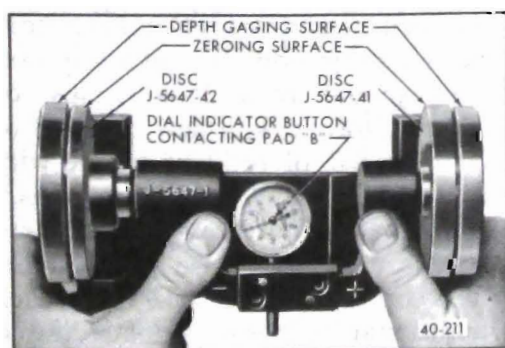

Figure 40-152 Zeroing Pinion Setting Gage

be located in centering hole of gage plate, and ball-tipped contact button of dial indicator must be positioned to bear against gage plate top surface.

9. Press gage yoke down firmly. Record number of thousandths dial indicator moves in a "+" (plus)

or "-" (minus) direction from zero. (Reading will usually be "

" (plus). Remove dial indicator from carrier and check zero setting on

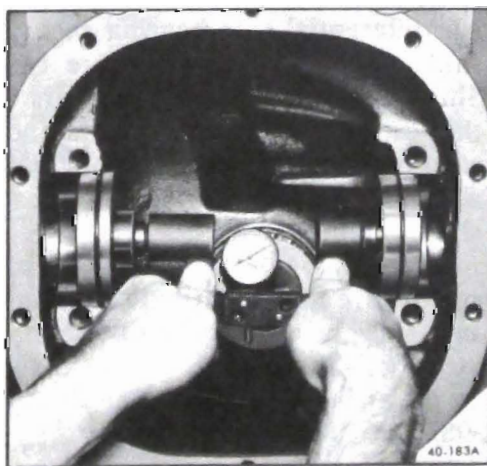

Figure 40-153 Checking Pinion Depth

master gage to make certain this setting was not disturbed by handling. If zero setting is still correct, remove gaging set-up (including 50 thousandths shim), then add a plus reading or subtract a minus reading from 50 thousandths. This answer indicates the thickness of the shims to be selected as further qualified in Step 11.

NOTE: The usual dial indicator reading will average from 1 to 10 thousandths in a plus direction with a corresponding shim thickness after computation of between 51 and 60 thousandths.

10. Examine ring gear and pinion for nicks, burrs or scoring. Any of these conditions will require replacement of the set.

11. The correct pinion shim to be used during pinion reassembly should be selected as follows:

a. If a production (marked) pinion is being reused and pinion is marked "+"

(plus), subtract the amount specified on the pinion from the shim thickness as determined in Step 9.

b. If a production (marked) pinion is being reused and the pinion is marked "-" (minus), add the amount specified on the pinion to the shim thickness as determined in Step 9.

c. If a service pinion is being used (no marking) shim pinion using shim thickness directly as determined in Step 9.

NOTE: Frequently, production pinions are nominal or zero pinions (no marking). When reusing a nominal production pinion, shim as with service pinion using shim thickness directly as determined in Step 9.

d. Assemble Differential Case Assembly

Before assembling the differential, examine the wearing surfaces of all parts for scoring or unusual wear. Also make certain that all parts are absolutely clean. Lubricate parts

with differential lubricant just before assembly.

1. Place side gear thrust washers over side gear hubs and install side gears in case. If same parts are reused, replace in original sides.

2. Position one pinion (without washer) between side gears and rotate gear until pinion is directly opposite from loading opening in case. Place other pinion between side gears so that pinion axle holes are in line, then rotate gears to make sure holes in pinions will line up with holes in case.

3. If holes line up, rotate pinions back toward loading opening just enough to permit sliding in pinion thrust washers.

4. Install pinion axle. Drive pinion axle retaining pin through hole in case and pinion axle until pin is flush with case.

5. Check matching numbers on ring gear and pinion to make sure the two parts have not been mixed with another gear set.

6. After making sure that mating surfaces of case and ring gear are clean and free of burrs, bolt ring gear to case using three Studs J-6251 to align parts. See Figure 40-154.

Do not use lock washers or any substitute bolts.

7. First tighten bolts alternately on opposite sides of the case to 35 lb.ft.

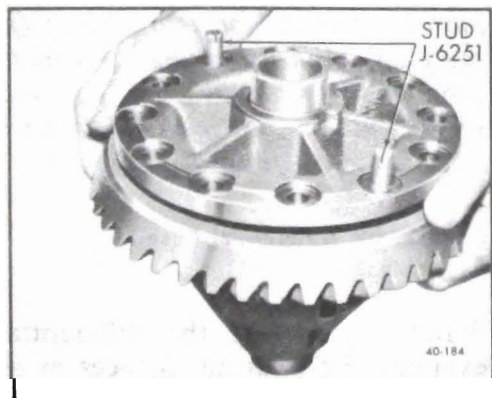

Figure 40-154 Installing Ring Gear on Differential Case

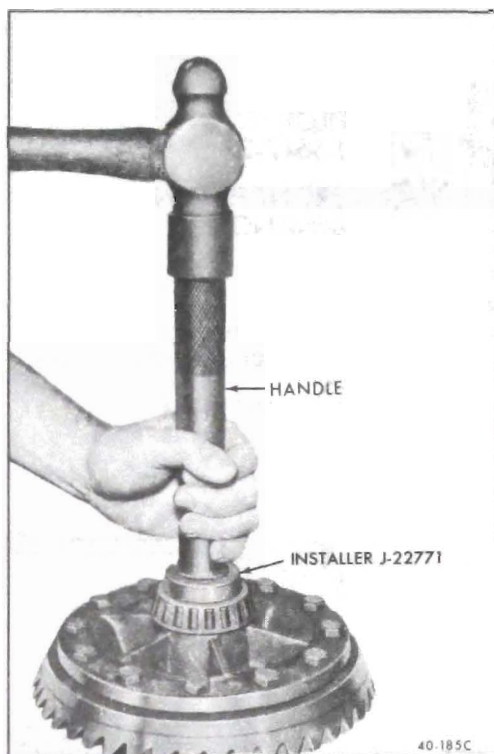

Figure 40-155 Installing Differential Side Bearings

torque, then tighten in the same manner to 85 lb.ft.

8. If differential side bearings were removed, install new bearings using Installer J-22771 with Driver Handle J-8092. See Figure 40-155.

e. Install Differential Case and Adjust Side Bearing Preload

Differential side bearing preload is adjusted by changing the thickness of both the right and left shims by an equal amount. By changing the thickness of both shims equally, the original backlash will be maintained. All differential side bearing preload shims used in production are cast. Shims used during service repairs of the differential are of a stamped steel design and are used along with a production type, .140" thick, cast shim. Stamped steel service shims must be used when differential repairs are made that require changing side bearing preload. Service, steel, adjusting shims are available in thicknesses ranging from .040" to .082" in increments of .002".

Before installation of case assembly, make sure that side bearing

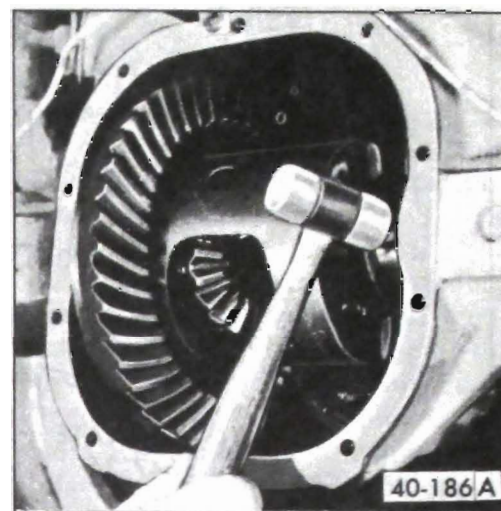

Figure 40-156 Installing Differential Adjusting Shims

surfaces in carrier are clean and free of burrs. Side bearings must be oiled with gear lube and if same bearings are being reused, they must have original outer races in place.

2. Place differential case and bearing assembly in position in carrier. Use service type adjusting shims totaling same thickness as production type adjusting shims if either new or reused bearings are to be used. Slip left shims in position at left bearing with steel shim next to bearing, then place .140" shim for right side in position and drive steel shim carefully into position between bearing and case shim using a soft hammer. See Figure 40-156

Install side bearing caps, as previously marked and tighten bolts to 53 lb.ft. before checking side bearing preload or backlash.

3. Rotate differential case assembly several complete turns to seat bearings. Check bearing preload using an inch pound torque wrench connected at pinion nut. Bearing preload should read 35-40 in.lbs. of rotating torque with new bearings or 20-25 in.lbs. of rotating torque with reused bearings. See Figure 40-148. If preload is not according to these specifications, increase shim thickness on each side .002" for each additional 10 in.lbs. preload desired or decrease shim thickness .002" on each side for each 10 in.lbs. preload to be subtracted.

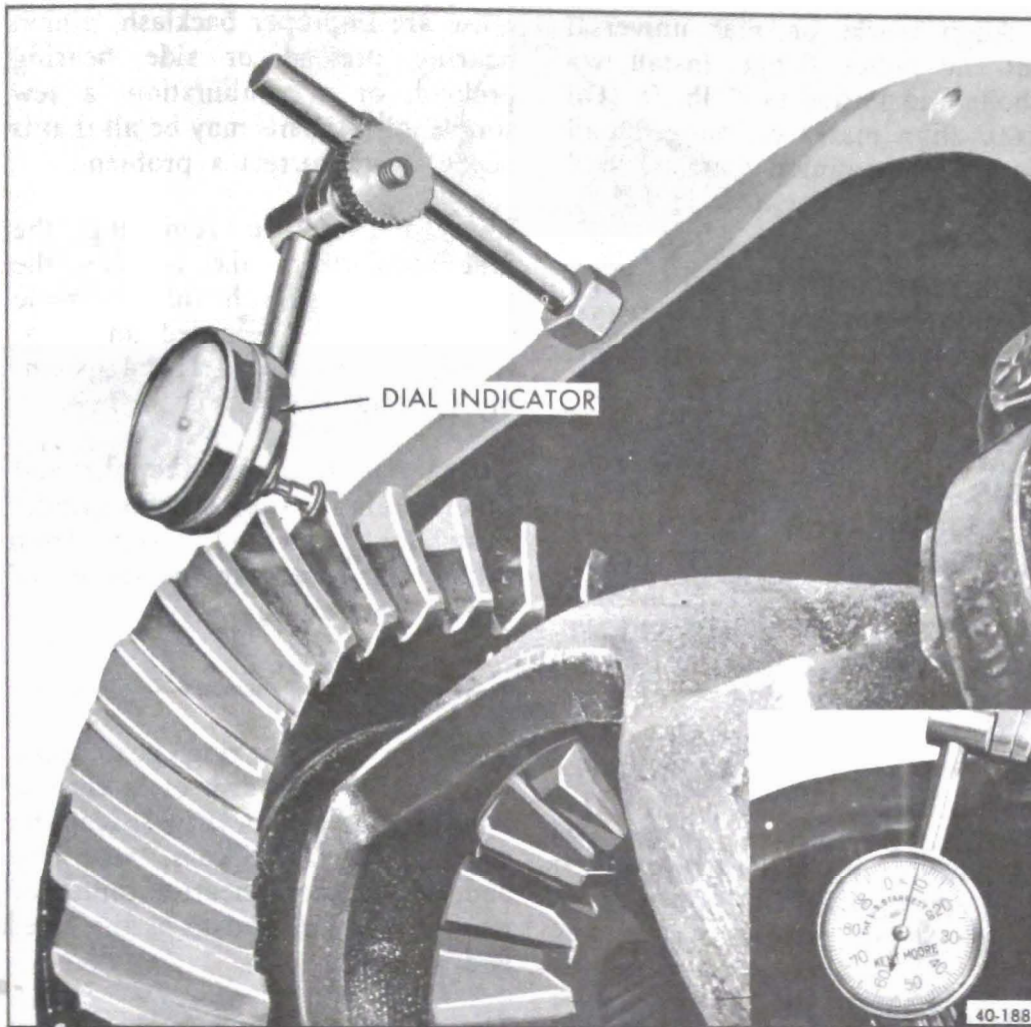

Figure 40-157 Checking Ring Gear to Pinion Backlash

f. Adjust Differential Backlash

1. Mount dial indicator as shown in Figure 40-157. Use a small button on indicator stem so that contact can be made near heel end of tooth. Set dial indicator so that stem is as nearly as possible in line with gear rotation and perpendicular to tooth angle for accurate backlash reading.

2. With pinion locked to carrier, check gear lash at 3 or 4 points around ring gear. Lash must not vary over .001" around ring gear.

If variation is over .001" check for burrs, uneven bolting conditions or distorted case flange and make corrections as necessary.

3. Gear lash at the point of minimum lash should be .007", .008", or .009" when using new ring gear and pinion. Backlash should be adjusted as near as possible to .008".

If original gear set having a wear pattern is being reinstalled, original gear lash should be maintained with

or - .001"

NOTE: Some original gear sets may be as tight as .006", or as loose as .010". Either of these maximum limits are acceptable for original production gear sets only.

4. If gear backlash is not within specifications, correct by increasing thickness of one differential shim and decreasing thickness of other shim the same amount. In this way, correct differential bearing preload will be maintained.

Shift .002" in shim thickness for each .001" change in backlash desired. If backlash is .002" too much, decrease thickness of right shim .004" and increase thickness of left shim .004". If backlash is .002" too little, increase thickness of right

shim .004" and decrease thickness of left shim .004".

5. Install new gasket on housing. Install cover. Torque cover bolts to 30 lb. ft. Wait 20 minutes and retorque cover bolts to specifications.

6. Install axle shaft assemblies as described in paragraph 40-36.

7. Install 4-1/4 pints of MPG SAE 80 or 80-90 (MIL- L-2105-B LUBRICANT or equivalent.)

NOTE: Fasteners in steps 8 and 9 are important attaching parts in that they could affect the performance of vital components and systems, and/or could result in major repair expense. It must be replaced with one of the same part number or with an equivalent part if replacement becomes necessary. Do not use a replacement part or lesser quality or substitute design. Torque values must be used as specified during reassembly to assure proper retention of this part.

8. Raise rear axle assembly and connect lower ends of both rear shock absorbers. Torque nuts to 45 lb. ft.

9. Align marks on rear universal joint and pinion flange. Install two U-bolts and torque to 12 lb. ft. (On 49000, align marks on flanged ball stud yoke and pinion flange. Install four bolts and torque to 85 lb. ft.)

10. Tighten parking brake cable and adjust as necessary.

11. Remove frame supports and lower car.

g. Install Pinion Oil Seal with Differential Installed in Car

1. Raise car and remove wheels and brake drums. Mark rear universal joint and pinion flange for proper alignment at reassembly. Then disconnect rear universal joint by removing two U-bolts. (On 49000, mark flanged ball stud yoke and rear pinion flange for proper alignment at reassembly. Then disconnect rear

CV joint by removing four pinion flange bolts.) Push propeller shaft forward as far as possible, then wire it to the upper control arm frame bracket to support it out of the way.

2. Install an inch pound torque wrench on pinion nut and record torque required to rotate pinion freely.

3. Mark position of pinion flange, pinion shaft threads and pinion nut so that proper preload can be obtained at reassembly.

4. Remove pinion flange nut and washer using Holder J-8614-01 to hold flange.

5. Remove flange.

6. Pry pinion oil seal out of assembly.

7. Examine oil seal running surface of flange for nicks or damaged surface. If damaged, replace flange.

NOTE: *If new companion flange is installed, the runout of the U-joint surfaces may cause some propeller shaft unbalance. In such a case, refer to Section C or D to correct.*

8. Examine carrier bore and remove any burrs that might cause leaks around O.D. of seal.

9. Coat O.D. of new pinion oil seal with sealing compound and install seal using Installer J-21005.

10. Coat lips of pinion oil seal and seal surface of pinion flange with gear lube. Install pinion flange on pinion by tapping with a soft hammer until a few pinion threads project through flange.

11. While holding pinion flange with Holder J-8614-01, install flange washer and nut. Tighten nut 1/8 turn beyond alignment marks on pinion shaft threads in order to preload collapsible spacer. Check preload using an inch pound torque wrench. Torque reading should be equal to or five inch pounds above that recorded in Step 2.

12. Align marks on rear universal joint and pinion flange. Install two U-bolts and torque to 12 lb. ft. (On 49000, align marks on flanged ball stud yoke and pinion flange. Install four bolts and torque to 85 lb. ft.)

NOTE: THIS PROPELLER SHAFT TO PINION FLANGE FASTENER IS AN IMPORTANT ATTACHING PART IN THAT IT COULD AFFECT THE PERFORMANCE OF VITAL COMPONENTS AND SYSTEMS, AND/OR COULD RESULT IN MAJOR REPAIR EXPENSE. IT MUST BE REPLACED WITH ONE OF THE SAME PART NUMBER OR WITH AN EQUIVALENT PART IF REPLACEMENT BECOMES NECESSARY. DO NOT USE A REPLACEMENT PART OF LESSER QUALITY OR SUBSTITUTE DESIGN. TORQUE VALUES MUST BE USED AS SPECIFIED DURING REASSEMBLY TO ASSURE PROPER RETENTION OF THIS PART.

DIVISION IV

TROUBLE DIAGNOSIS

40-39 PRE-REPAIR INVESTIGATION AND TROUBLE DIAGNOSIS ALL MODELS

The pinion and ring gear must be completely assembled, installed and all preload and backlash adjustments completed prior to the start of this method of pinion depth setting. The following procedure can be used in place of the gage method of pinion depth setting.

A close examination of the differential prior to disassembly will often reveal valuable information as to the extent and type of repairs or adjustments necessary. The information thus gained, coupled with the report of malfunctioning will provide a basis for determining the degree of disassembly required. Since the frequent cause of axle

noise are improper backlash, pinion bearing preload or side bearing preload, or a combination, a few simple adjustments may be all that is necessary to correct a problem.

Therefore, before removing the differential from the housing the following checks should be made with the results recorded and analyzed; (1) Backlash, (2) Total Assembly Preload, (3) Red Lead Test.

Use care at all times to keep dirt and other foreign matter, such as grinder dust, soot or sand, away from differential to prevent possibility of subsequent failure.

a. Gear Tooth Nomenclature

The side of the ring gear tooth which curves outward, or is convex, is referred to as the "drive" side. The concave side is the "coast" side. The end of the tooth nearest center of ring gear is referred to as the "toe" end.

The end of the tooth farthest away from center is the "heel" end. Toe end of tooth is smaller than heel end. It is very important that tooth contact be tested before the differential carrier assembly is disassembled. Variations in the carrier or pinion rear bearing may cause the pinion to be too far away from, or close to, the ring gear. Thus, the tooth contact must be tested and corrected if necessary, or the gears may be noisy.

b. Red Lead Test

1. Wipe oil out of carrier and carefully clean each tooth of ring gear.

2. Mix a small amount of powdered red lead (available from paint manufacturers and suppliers) with a few drops of rear axle lubricant (until the powder is just moist) and apply this mixture sparingly to all ring gear teeth using a medium stiff brush. When properly used, the area of pinion tooth contact will be visible when hand load is applied.

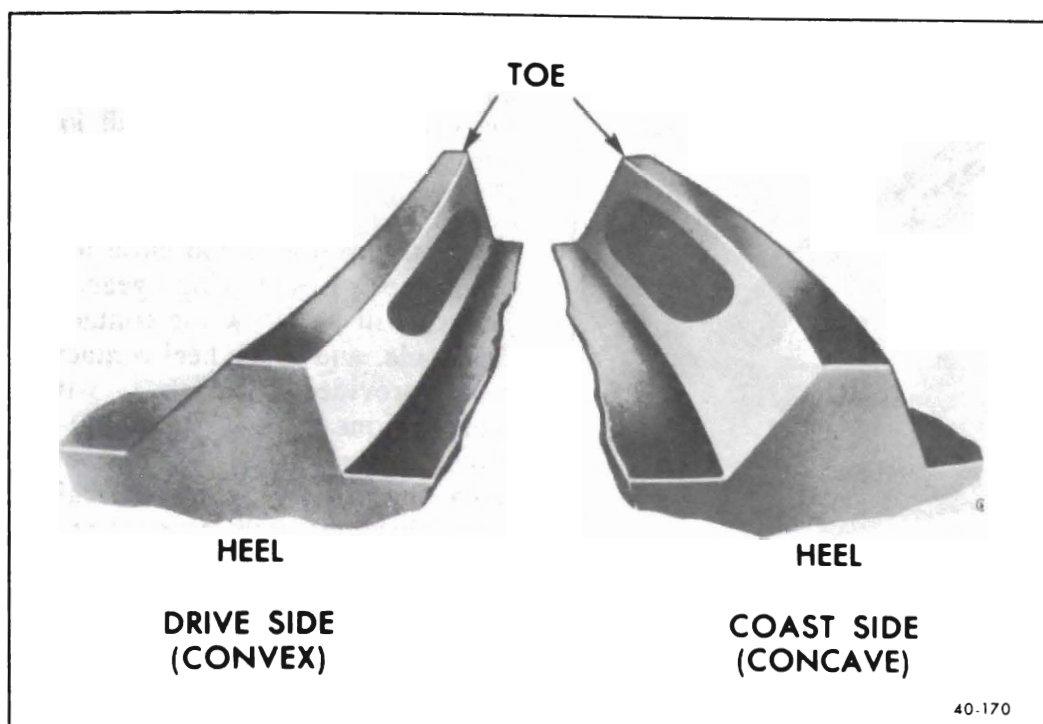

Figure 40-158 Gear Tooth Nomenclature

3. Tighten bearing cap bolts to 55 lb. ft.

4. Expand brake shoes until a torque of 40-50 lb.ft. is required to turn the pinion.

A test made without loading the

gears will not give a satisfactory pattern. Turn companion flange with wrench so that ring gear rotates one full revolution then reverse rotation so that ring gear rotates one revolution in opposite direction. Excessive turning of ring gear may indicate good tooth pattern because one or

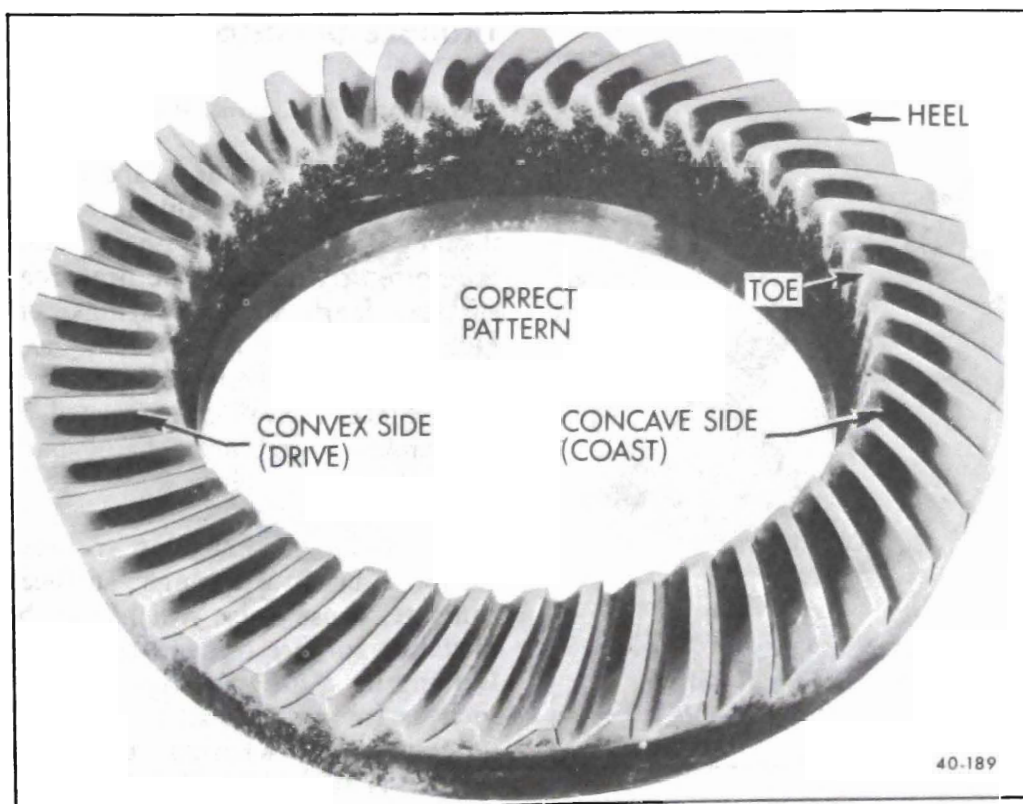

Figure 40-159 Desired Tooth Contact Under Light Load

two teeth are making proper contact.

5. Observe pattern on ring gear teeth and compare with Figures 40-158 and 40-159.

c. Effects of Increasing Load on Tooth Contact Pattern

When "load" on ring and pinion gear is increased, such as when car is accelerated forward from standstill or from normal drive, the tooth contact will tend to spread out, and under very heavy load will extend from near toe to near heel on the drive side. The entire contact also tends to shift toward heel under increasingly heavier loads and will become somewhat broader with respect to tops and bottoms of teeth. The patterns obtained by red lead tests, dependent upon degree of "loading", approximate a normal light load. For this reason, they will extend only about halfway.

The important thing to note is that the contact pattern is centrally located up and down on the face of the ring gear teeth.

d. Adjustments Affecting Tooth Contact

Two adjustments can be made which will affect tooth contact pattern, backlash, and position of drive pinion in carrier. The effects of bearing preloads are not readily apparent on (hand loaded) red lead tests; however, these adjustments should be within specifications before proceeding with backlash and drive pinion adjustments.

Backlash is adjusted by means of the side bearing adjusting shims which moves the entire case and ring gear assembly closer to, or farther from, the drive pinion. (The adjusting shims are also used to set side bearing preload.)

The position of the drive pinion is adjusted by increasing or decreasing the shim thickness between the pinion head and inner race of rear bearing. The shim is used in the differential to compensate for manu-

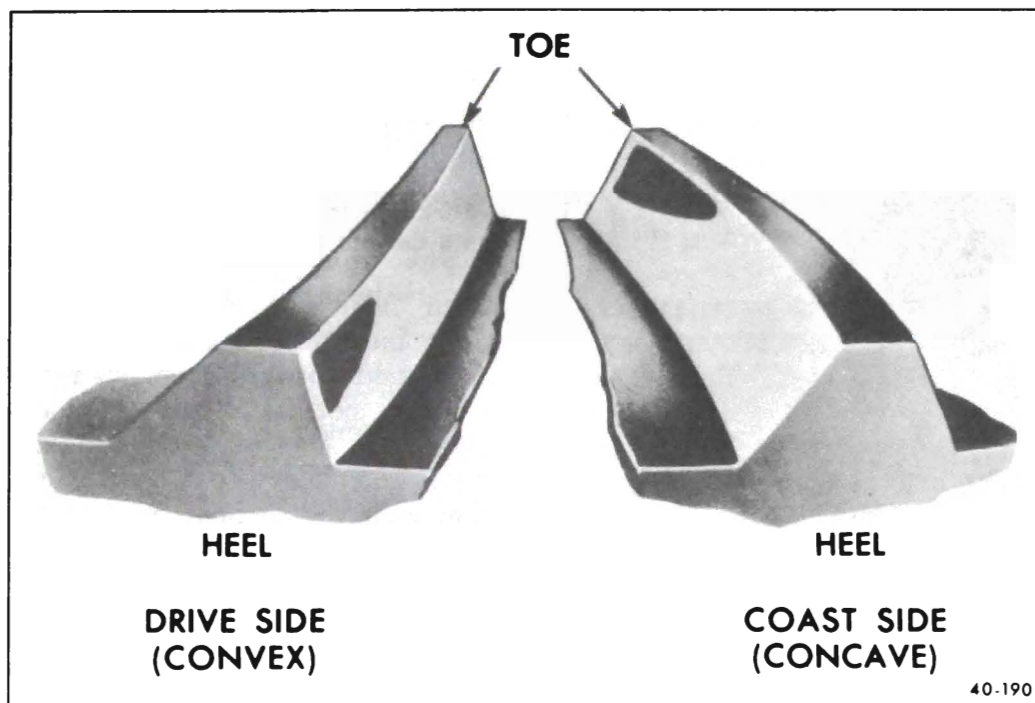

Figure 40-160 Tooth Pattern - Pinion too Far Away from Ring Gear (Insufficient Shim Thickness)

facturing tolerances. Increasing shim thickness will move the pinion closer to centerline of the ring gear. Decreasing shim thickness will move pinion farther away from centerline of the ring gear.

e. Effects of Pinion Position on Tooth Pattern

When the drive pinion is too far away from centerline of the ring gear, the pattern will be a high heel contact on drive side and high toe contact on coast side, provided backlash is within specifications of .007", .008", .009". See Figure 40-160. Moving the pinion closer to centerline of the ring gear by increasing

shim thickness will cause the high heel contact on drive side to lower and move toward the toe; the high toe contact on coast side will lower and move toward the heel. See Figure 40-161.

When the pinion is too close to the centerline of the ring gear, the pattern will be a low toe contact on drive side, and a low heel contact on coast, provided backlash is within specifications. See Figure 40-162. Moving the pinion farther away from the ring gear by decreasing shim thickness will cause low toe contact on drive side to raise and move toward the heel; the low heel contact on coast side will raise and move toward the toe. See Figure 40-163.

NOTE: *Whenever the rear axle is overhauled to the point of requiring a new ring gear and pinion set, the rear axle should be filled ONLY with the lubricant included with the gear set. Whenever the rear axle is overhauled to the point of requiring only pinion and/or side bearings, it is recommended that lubricant 5.535 - 1050081 or equivalent be used to refill for positive traction units or 5.535 - 1388901 or equivalent for regular units.*

TROUBLE DIAGNOSIS

a. Elimination of External Noises

When a rear axle is suspected of being noisy it is advisable to make a thorough test to determine whether the noise originates in the tires, road surface, front wheel bearings, engine, transmission, or rear axle assembly. Noise which originates in other places cannot be corrected by adjustment or replacement of parts in the rear axle assembly.

(1) *Road Noise.* Some road surfaces, such as brick or rough surfaced concrete, cause noise which may be mistaken for tire or rear axle noise. Driving on a different type of road, such as smooth asphalt or dirt, will quickly show whether the road surface is the cause of noise. Road noise usually is the same on drive or coast.

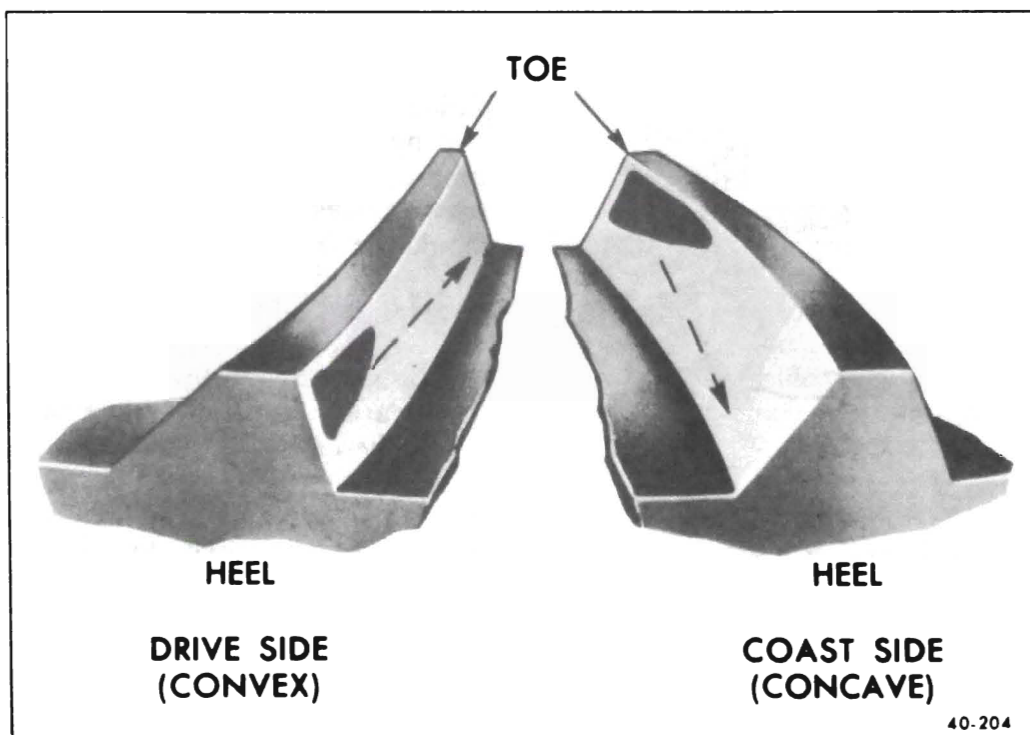

Figure 40-161 Effect on Pattern as Shim Thickness is Increased

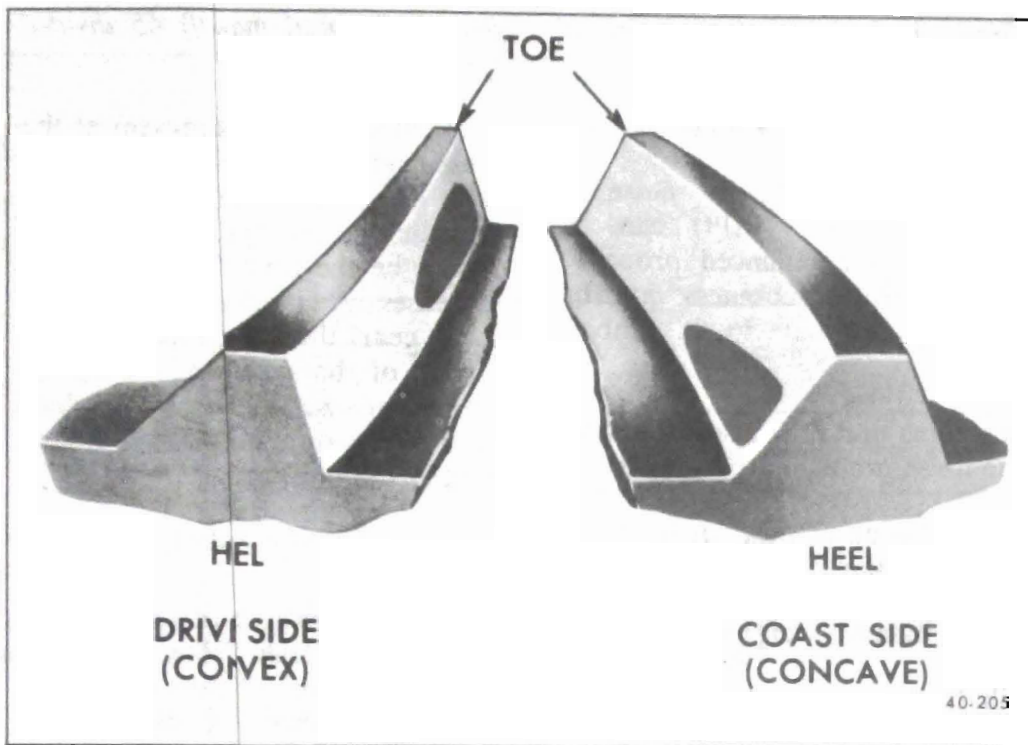

Figure 40-162 Tooth Pattern - Pinion too Close to Ring Gear (Excessive Shim Thickness)

(2) *Tire Noise* Tire noise may easily be mistaken for rear axle noise even though the noisy tires may be located on the front wheels. Tires worn unevenly or having surfaces on non-skid divisions worn in saw-tooth fashion are usually noisy, and may produce vibrations

which seem to originate elsewhere in the vehicle. This is particularly true with low tire pressure. (3) *Test for Tire Noise* Tire noise changes with different road surfaces, but rear axle noise does not. Temporarily inflating all tires to approximately 50 pounds pressure, for test purposes only, will

materially alter noise caused by tires, but will not affect noise caused by rear axle. Rear axle noise usually ceases when coasting at speeds under 30 miles per hour; however, tire noise continues but with lower tone as car speed is reduced. Rear axle noise usually changes when comparing "pull" and "coast", but tire noise remains about the same.

(4) *Front Wheel Bearing Noise* Loose or rough front wheel bearings will cause noise which may be confused with rear axle noises; however, front wheel bearing noise does not change when comparing "pull" and "coast". Light application of brake while holding car speed steady will often cause wheel bearing noise to diminish as this takes some weight off the bearing. Front wheel bearings may be easily checked for noise by jacking up the wheels and spinning them, also by shaking wheels to determine if bearings are loose.

(5) *Engine and Transmission Noises* Sometimes a noise which seems to originate in the rear axle is actually caused by the engine or transmission. To determine which unit is actually causing the noise, observe approximate car speeds and conditions under which the noise is most pronounced; then stop car in a quiet place to avoid interfering noises. With transmission in neutral, run engine slowly up and down through engine speeds corresponding to car speed at which the noise was most pronounced. If a similar noise is produced with car standing, it is caused by the engine or transmission, and not the rear axle.

b. Rear Axle Noises

If a careful test of car shows that noise is not caused by external items as described in subparagraph a, it is then reasonable to assume that noise is caused by rear axle assembly. The rear axle should be tested on a smooth level road to avoid road noise. It is not advisable to test rear axle for noise by running with rear wheels jacked up.

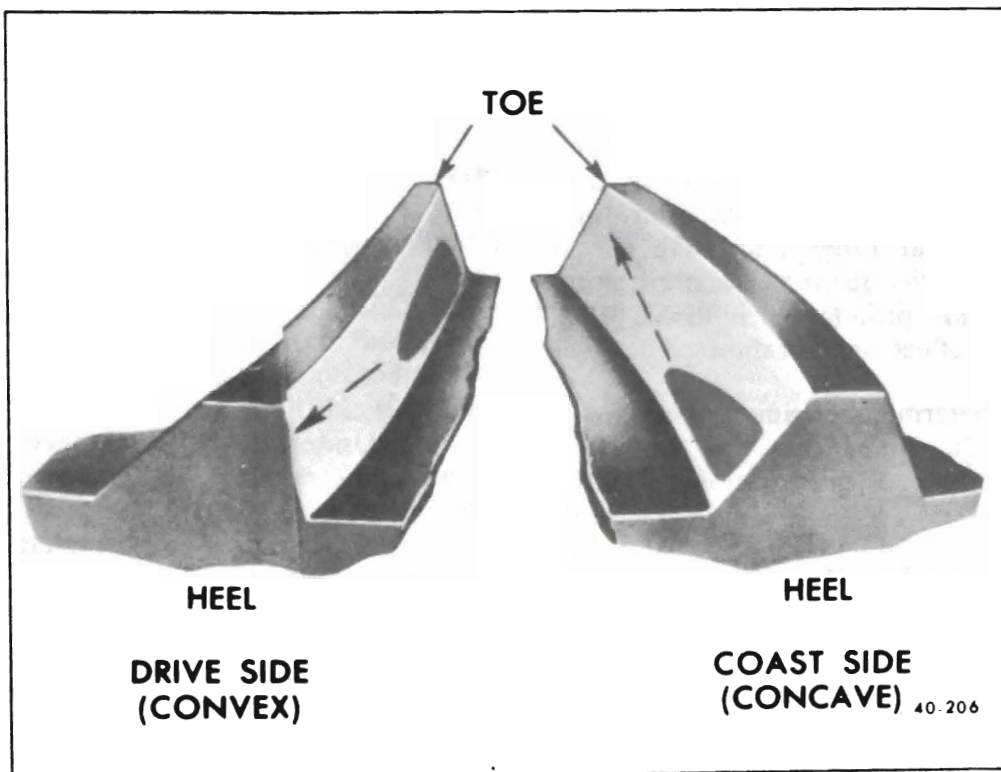

Figure 40-163 Effect on Tooth Pattern as Shim Thickness is Decreased

Noises in rear axle assembly may be caused by a faulty propeller shaft, faulty rear wheel bearings, faulty differential or pinion shaft bearings, misalignment between two U-joints, or worn differential side gears and pinions; noises may also be caused by mismatched, improperly adjusted, or scored ring and pinion gear set.

(1) *Rear Wheel Bearing Noise.* A rough rear wheel bearing produces a vibration or growl which continues with car coasting and transmission in neutral. A brinelled rear wheel bearing causes a knock or click approximately every two revolutions of rear wheel, since the bearing rollers do not travel at the same speed as the rear axle and wheel. With rear wheels jacked up, spin rear wheels *by hand* while listening at hubs for evidence of rough or brinelled wheel bearing.

(2) *Differential Side Gear and Pinion Noise.* Differential side gears and pinions seldom cause noise since their movement is relatively slight on straight ahead driving. Noise produced by these gears will be most pronounced on turns.

(3) *Pinion Bearing Noise.* Rough or brinelled pinion bearings produce a continuous low pitch whirring or scraping noise starting at relatively low speed.

(4) *Ring and Pinion Gear Noise.* Noise produced by the ring and pinion gear set generally shows up as drive noise, coast noise, or float noise.

(a) Drive noise is noise produced during vehicle acceleration.

(b) Coast noise is noise produced while allowing car to coast with throttle closed.

(c) Float noise is noise occurring while just maintaining constant car speed at light throttle on a level road.

(d) Drive, coast, and float noises will vary in tone with speed, and will be very rough and irregular if the

differential or pinion shaft bearings are rough, worn, or loose.

c. Body Boom Noise or Vibration

Objectional "body boom" noise or vibration at 55-65 MPH can be caused by an unbalanced propeller shaft. Excessive looseness at the spline can contribute to this unbalance.

Other items that may also contribute to the noise problem are as follows:

1. Undercoating or mud on the shaft causing unbalance.
2. Shaft balance weights missing.
3. Shaft damage such as bending, dents or nicks.
4. Tire-type roughness. Switch tires from a known good car to determine tire fault.

d. Check for Propeller Shaft Vibration

Objectionable vibrations at high speed (65 MPH or higher) may be caused by a propeller shaft that is out of balance. Out of balance may be due to a bent shaft.

To determine whether propeller shaft is causing vibration, drive car through speed range and note speed at which vibration is most pronounced. Shift transmission into lower gear range and drive car at same *engine speed* as when vibration was most pronounced in direct drive. Note effect on vibration.

To determine engine speed, divide vehicle speed by the following transmission gear ratios as listed below:

EXAMPLE: *If vibration is most pronounced in direct drive at 65 mph, the same engine speed would be produced in second gear (L-6, three-speed manual) at 65 divided by 1.68=39 mph; in low range second gear (THM 350) at 65 divided by 1.52=42 mph; in low range second gear (THM 400) at 65 divided by 1.51=43 mph; in second*

gear (four-speed manual) 65 divided by 1.64= 40 mph.

If the vibration is still present at the *same engine speed* whether in direct drive or in the low gear, since the propeller shaft speed varies, this cannot be the fault. If the vibration decreases or is eliminated in the lower gear, then the propeller shaft is out of balance and should be rebalanced. See Section C for balancing procedure and more complete trouble diagnosis.

e. Oil Leaks

It is difficult to determine the source of some oil leaks. When there is evidence of an oil leak, determine source as follows:

(1) Oil coming from the drain hole under the axle housing at the brake backing plate is caused by a leaking axle shaft seal or a leaking wheel bearing inner gasket.

(2) Oil coming from between the rear pinion flange slinger and the carrier is caused by a leaking pinion seal.

Even after the point of leakage has been determined it is hard to tell whether the oil is leaking past the lip of the seal or past the O.D. of the seal. Therefore it is a good idea to make sure the leak is stopped by using a non-hardening sealing compound around the O.D. of the new seal.

(3) Oil leaking at the junction of the axle tubes to the carrier or at the puddle weld holes are difficult to repair. Under no circumstances should any welding be done in attempts to stop leaks in these areas. If the leak is severe, the complete rear axle housing should be replaced.

40-40 CHECKING REAR AXLE TOE AID CAMBER (ALL MODELS)

The following method is given for

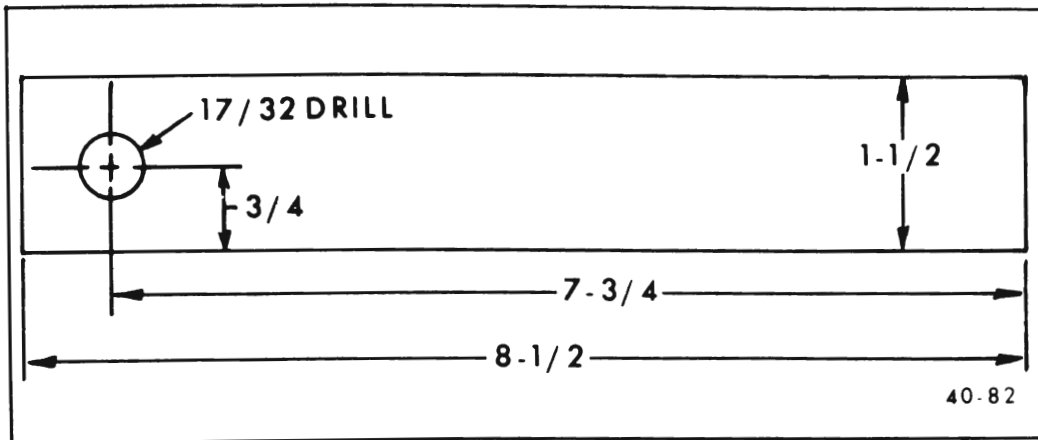

Figure 40-164 Special Tool Fabrication Specifications

checking alignment (toe and camber) of rear axle assemblies.

It is recommended that no straightening be done due to danger of cracking the differential carrier during the straightening process.

If any rear axles are found to be outside of limits specified, it is recommended that the housing be changed.

a. Special Tools

Using 1/4" thick bar stock, fabricate

two identical special tools as shown in Figure 40-164.

b. Checking Instructions

1. Jack up the vehicle so that the rear wheels clear the floor and put two stands under the axle near the spring seats.

2. Raise the body so that there is working clearance between the body and the axle.

3. Remove the wheels and brake drums.

4. With dial indicator, measure

runout of axle shaft flange and wheel pilot diameter. Runout should not exceed .008 total indicator reading on flange and .005 total indicator reading on pilot diameter. If readings are within specifications continue with Step 5.

5. Attach the two special tools to the wheel studs and secure with wheel nuts.

6. Turn both tools in as near horizontal position as possible to a point toward front of vehicle where a tape measure can be stretched from end of one tool to the other without hitting any obstructions. Measure and record this distance.

7. Rotate tools 180° by turning pinion and measure again. The tolerances are shown in Figure 40-165.

8. Turn both tools to an upward vertical position. Measure and record this distance.

9. Rotate tools 180° by turning pinion and measure again. The tolerances are shown in Figure 40-165.

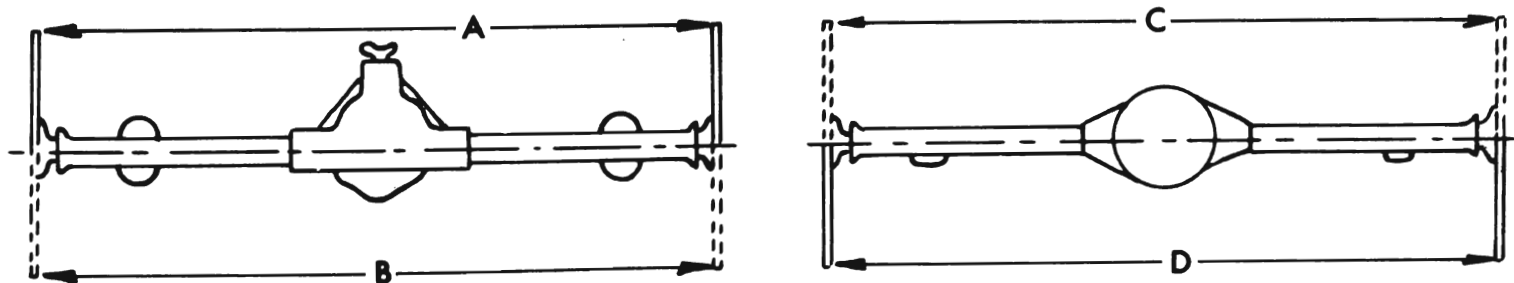

"A" May be Equal to "B" or up to 7/64" Greater
 "A" Should Never be Less Than "B"
 "C" May be Equal to "D" or up to 7/64" Greater
 "C" Should Never be Less Than "D"

40-83B

Figure 40-165 Checking Rear Axle Toe and Camber