

SECTION A

43-44000 FRAME AND BODY MOUNTINGS

CONTENTS

Division	Subject	Paragraph
I	SPECIFICATIONS AND ADJUSTMENTS: Body Mount Specifications.....	20-1
II	DESCRIPTION AND OPERATION: Description of Body Mounts.....	20-2
III	SERVICE PROCEDURES: Removal and Installation of Body Mounts.....	20-3
IV	TROUBLE DIAGNOSIS: Trouble Diagnosis	20-4

20A-3

DIVISION I SPECIFICATIONS AND ADJUSTMENTS

20-1 BODY MOUNT SPECIFICATION AND ADJUSTMENT

See diagrams for correct installation and torque specifications.

DIVISION II DESCRIPTION AND OPERATION

20-2 DESCRIPTION OF BODY MOUNTS

The body of the car is mounted to the chassis by means of thick rubber

mounts. These mounts are specifically designed for each location to give the maximum amount of structure rigidity while at the same time providing optimum road noise isolation. Two basically different mounts are used for this purpose. At those locations where a bolt is used, the mounting consists of a load carrying mount which rests on top of the frame side rails or mounting brackets, a metal tube spacer which limits the amount of compression of the mount and an insulator which fits on the bottom side of the frame side rail surface. All bolt-in body mounts have a specified bolting torque.

The second type of body mount used is of a plug-in design and has no mounting bolt. This mount plugs into a mounting hole on top of the frame side rail or rear spring seat and acts as a steady rest for the body.

DIVISION III SERVICE PROCEDURES

20-3 REMOVAL AND INSTALLATION OF BODY MOUNTS

The removal of any one body mount necessitates the loosening of adjacent body mountings to permit the frame to be separated from the body.

During installation of a body mount, caution should be used to insure that the body mount is properly seated in the frame mounting hole, otherwise a direct metal to metal short circuit will result between the frame and body. The tube spacer should be in all bolt-in body mounts and the insulator and metal washer posi-

tioned to prevent the washer from contacting the frame side rail. Do not use lubricants of any kind on the rubber parts of the mounts. Proper clamping by the mount depends on clean and dry surfaces. Do not over-torque the body mount or a collapsed tube spacer or stripped bolt will result. Lubricating the bolt threads will result in a higher clamping force for the same torque setting. If the body mount bolt does not screw in smoothly, it may be

necessary to run a tap through the cage nut in the body to remove foreign material. If caution is not observed, broken body mount bolts may result.

DIVISION IV

TROUBLE DIAGNOSIS

20-4 TROUBLE DIAGNOSIS

Improper body mount installations

may result in the following problems:

1. Structure shake
2. Road noise
3. Squeaks

The above problems can sometimes be caused by the wrong part being installed or the mount not being properly torqued.

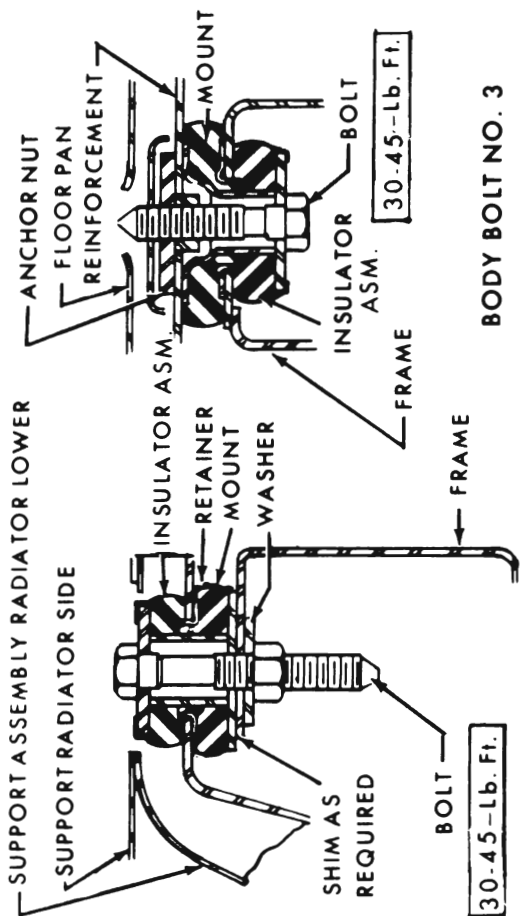

BODY BOLT NO. 3

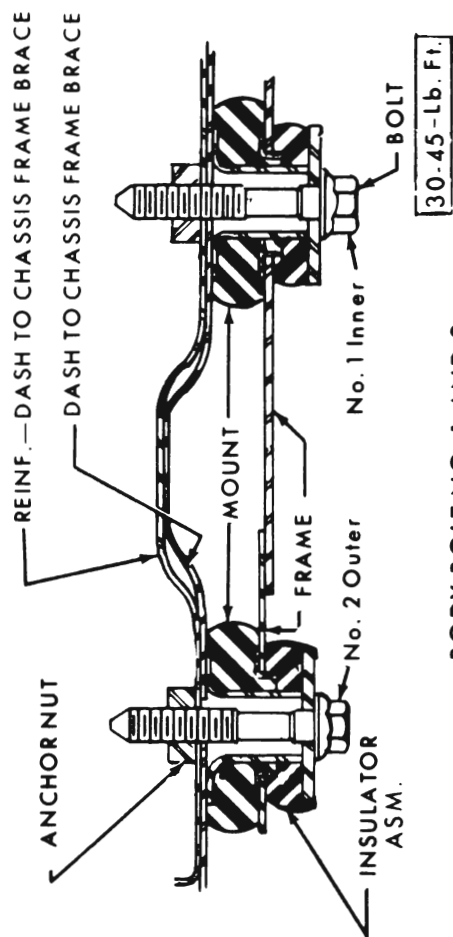

BODY BOLT NO. 1 AND 2

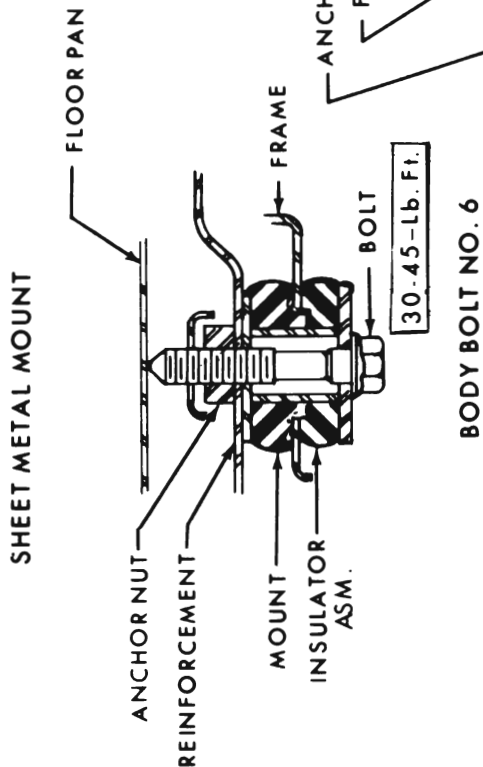

BODY BOLT NO. 6

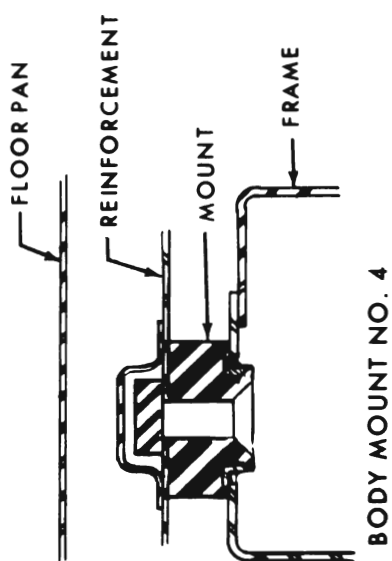

BODY MOUNT NO. 4

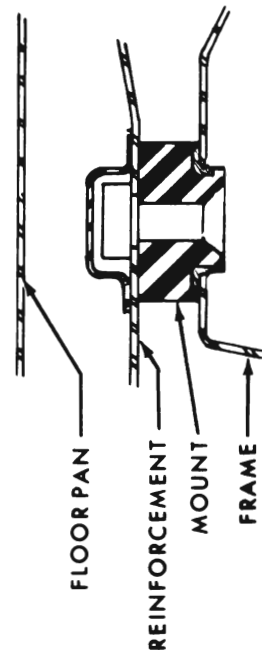

BODY MOUNT NO. 5
ALL BODIES

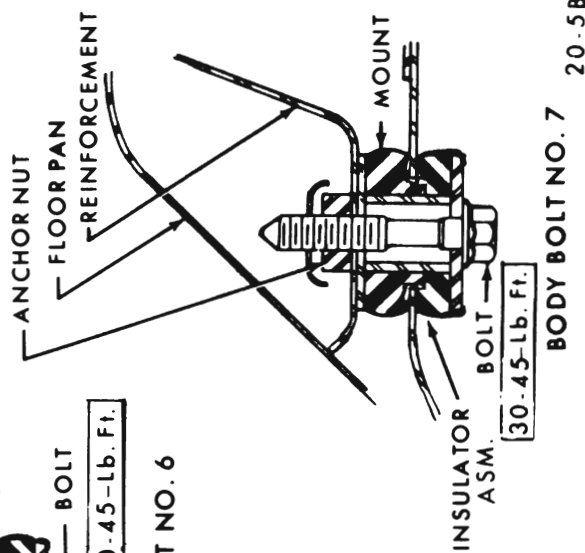

BODY BOLT NO. 7 20-5B

Figure 20-1 - 43-44000 Body Mounts

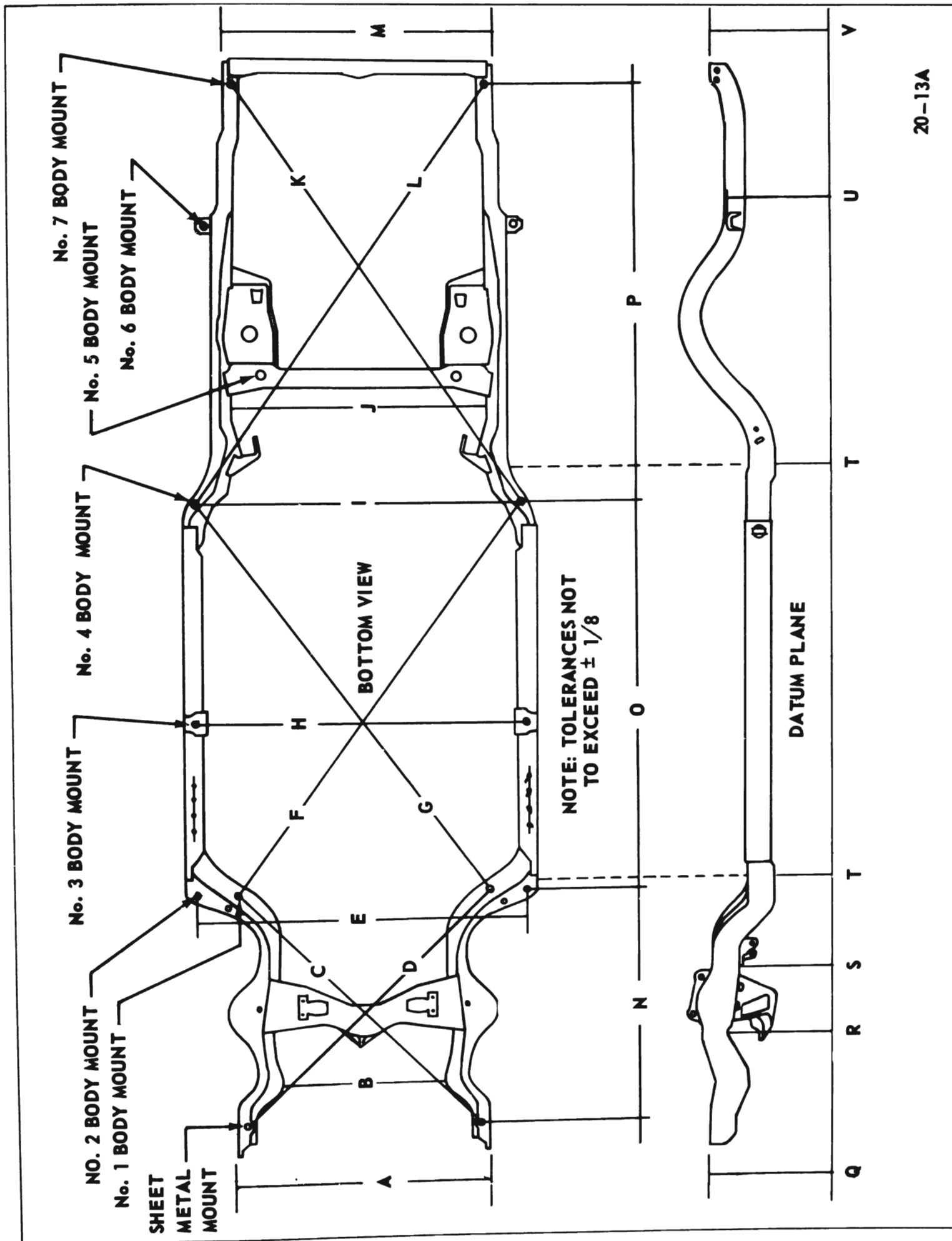
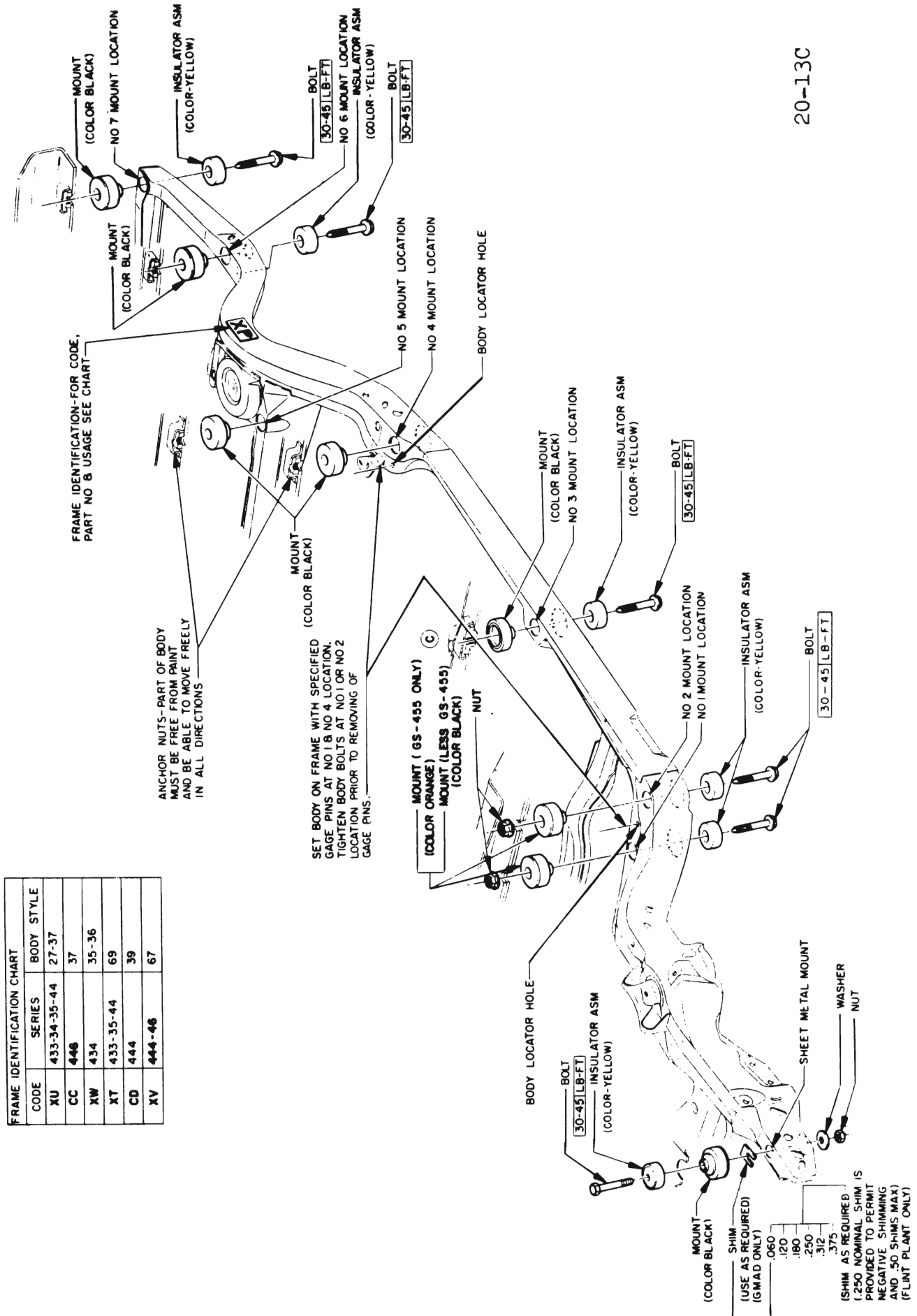

Figure 20.2 · 43-44000 Frame Details

20-6 43-44000 FRAME AND BODY MOUNTINGS

112"	116"	Wheelbase
2-Dr. Coupe TP	4-Dr. Sedan TP	Skylark
2-Dr. Coupe Hardtop		G.S.
2-Dr. Coupe Hardtop	4-Dr. Sedan TP	Skylark .350
2-Dr. Coupe Hardtop 2-Dr. Convertible	4-Dr. Hardtop 4-Dr. Sedan TP	Skylark Custom
	4-Dr. 2-Seat Wagon	Sportwagon
2-Dr. Coupe Hardtop 2-Dr. Convertible		G.S. 455
A	41 ³ / ₈	Outside edge to outside edge of frame horns.
B	28 ¹ / ₂	Between frame siderails at lower steering gear bolt hole and idler arm mounting surface.
C	60 ³ / ₈	Center of left sheet metal mount bolt head to center of right number 2 body mount bolt head.
D	60 ³ / ₈	Center of left sheet metal mount bolt head to center of left number 2 body mount bolt head.
E	52 ³ / ₈	Center of left number 2 body mount bolt head to center of right number 2 body mount bolt head.
F	73	Center of left number 1 body mount bolt head to center of right number 4 body mount bolt head.
G	73	Center of right number 1 body mount bolt head to center of left number 4 body mount bolt head.
H	53	Center of left number 3 body mount bolt head to center of right number 3 body mount bolt head.
I	48 ¹ / ₈	Center of left number 4 body mount bolt head to center of right number 4 body mount bolt head.
J	40 ³ / ₈	Between frame side rails ahead of cross member.
K	82 ¹ / ₈	Center of left number 4 body mount bolt head to center of right number 7 body mount bolt head.
L	82 ¹ / ₈	Center of right number 4 body mount bolt head to center of left number 7 body mount bolt head.
M	43 ¹ / ₈	Outside edge to outside edge at rear of frame side rails.
N	46 ³ / ₄	Center of sheet metal mount bolt head to center of number 2 body mount bolt head (Either Side).
O	50 ¹ / ₈	Center of number 2 body mount bolt head to center of number 4 body mount bolt head (Either Side).
P	69 ¹ / ₄ (Wagon 75 ¹ / ₄)	Center of number 4 body mount bolt head to center of number 7 body mount bolt head (Either Side).
Q	15	Top edge of frame horn to datum plane.
R	11 ⁷ / ₈	Bottom surface of frame directly ahead of coil spring hole to datum plane.
S	10	Bottom surface of frame at "A" frame rear bracket to datum plane.
T	5	Locations for mounting #2 and #3 datum gages. Adjust sight pins to 5" below bottom edge of frame.
U	13	From top edge of number 6 body mount bracket to datum plane.
V	15 ³ / ₄ (Wagon 14 ¹ / ₂)	From top rear surface of frame to datum plane.

Figure 20-3 · Frame Dimensions · 43-44000



20-13C

Figure 20-4 - Body Mount and Frame Usage - 43-44000