

SECTION A

HEATER – AIR CONDITIONER SYSTEM

ALL SERIES

CONTENTS

Division	Subject	Paragraph
I	SPECIFICATIONS AND ADJUSTMENTS: Specifications Adjustment of Temperature Lever and Temperature Door Adjustment of Outside Air Inlet Door	13-1 13-2 13-3
II	DESCRIPTION AND OPERATION: General Description of System Description of Air Flow Thru System Operation of Instrument Panel Controls Operation of Heater Portion of System Operation of Air Conditioner Portion of System Description of Air Conditioning Components	13-8 13-9 13-10 13-11 13-12 13-13
III	SERVICE PROCEDURES: (Servicing Refrigerant Charged Components) General Service Information and Safety Precautions Discharging System Adding Oil to System Flushing System Removal and Installation of Compressor Disassembly and Assembly of Compressor Clutch Drive Plate and Shaft Seal Disassembly and Assembly of Compressor Pulley Assembly, and Coil and Housing Assembly Disassembly and Assembly of Internal Parts of Compressor and Leak Testing Removal and Installation of Muffler Removal and Installation of Condenser Removal and Installation of Receiver-Dehydrator Removal and Installation of Expansion Valve Removal and Installation of Evaporator Removal and Installation of POA Valve Charging System (Servicing Air Distribution Components) Removal and Installation of Blower Motor Removal and Installation of Air Conditioner-Heater Assembly, Heater Core or Air Distributor Ducts Removal and Installation of Air Conditioner Control Assembly	13-14 13-15 13-16 13-17 13-18 13-20 13-21 13-22 13-23 13-24 13-25 13-26 13-27 13-28 13-29 13-30 13-31 13-32
IV	TROUBLE DIAGNOSIS: General Information Leak Testing System Functional Testing System Heater-Air Conditioner Vacuum and Electrical Circuits Test Sequence and Trouble Diagnosis Table Heater-Air Conditioner Refrigerant Circuit Trouble Diagnosis Chart	13-33 13-34 13-35 13-36 13-37

DIVISION I SPECIFICATIONS AND ADJUSTMENTS

13-1 SPECIFICATIONS

a. Tightening Specifications

Part	Location	Torque Lb. Ft.
Nut	Drive Plate Nut to Compressor Shaft	15
Nut	Rear Head to Shell	21
Cap	Schrader Service Valve	5

b. Compressor Specifications

Type	Six Cylinder Axial Opposed
Make	Frigidaire
Effective Displacement (cu. in.)	12.6
Oil	525 Viscosity
Oil Content (New)	10½ fl. oz.
Air Gap Between Clutch Drive Plate and Pulley	0.022 to 0.057 inch
Clutch Type	Magnetic
Belt Tension	100 lbs.

Metal Tube Outside Diameter	Thread and Fitting Size	Steel Tubing Torque Lb.-Ft.	Aluminum or Copper Tubing Torque Lb. Ft.	Nominal Torque Wrench Span
¼	7/16	10-15	5-7	5/8
3/8	5/8	30-35	11-13	¾
5/8	7/8	30-35	21 - 27	1 1/16
¾	1 1/16	30-35	28 -33	1 ¼

If a connection is made with steel to aluminum or copper, use torques for aluminum. In other words, use the lower torque specification.

Use steel torques *only* when *both* ends of connection are steel.

Figure 13-1 Pipe and Hose Connection Torque Chart

c. General Specifications

Thermostat Opening Temperature	
L-6	190°
V-8 (All)	195°
Capacity of Cooling System with Air Conditioner (Quarts)	
L-6	16.0
V-8, 350 cu. in.	16.5
V-8, 430 cu. in.	20.0
Type of Refrigerant	Refrigerant 12
Refrigerant Capacity (Fully Charged)	
43-44000 Series	3¾ lbs.
45-46-48-49000 Series	4¼ lbs.

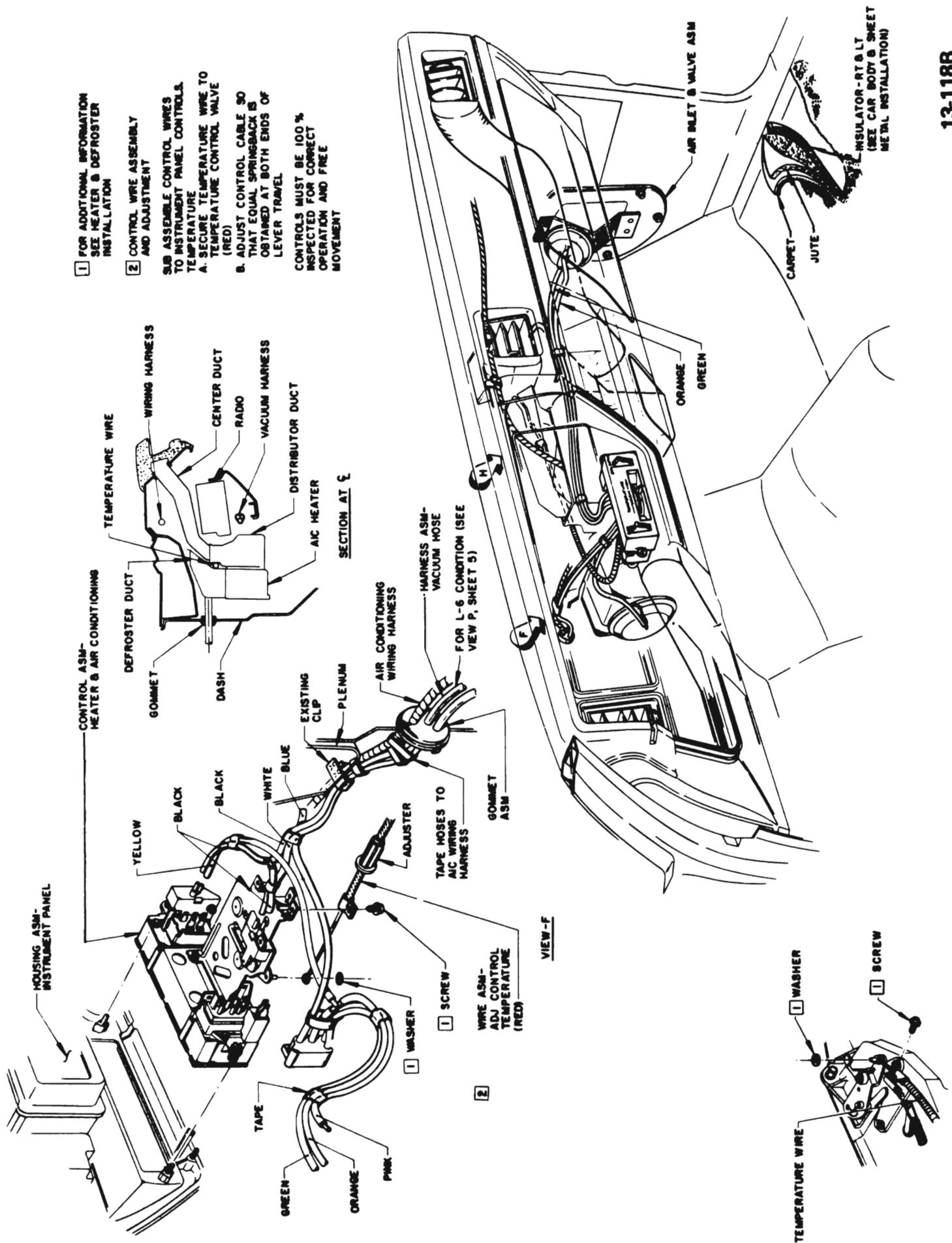

13-118B

Figure 13-2 43-44000 Series Control Wire and Vacuum Hose Installation

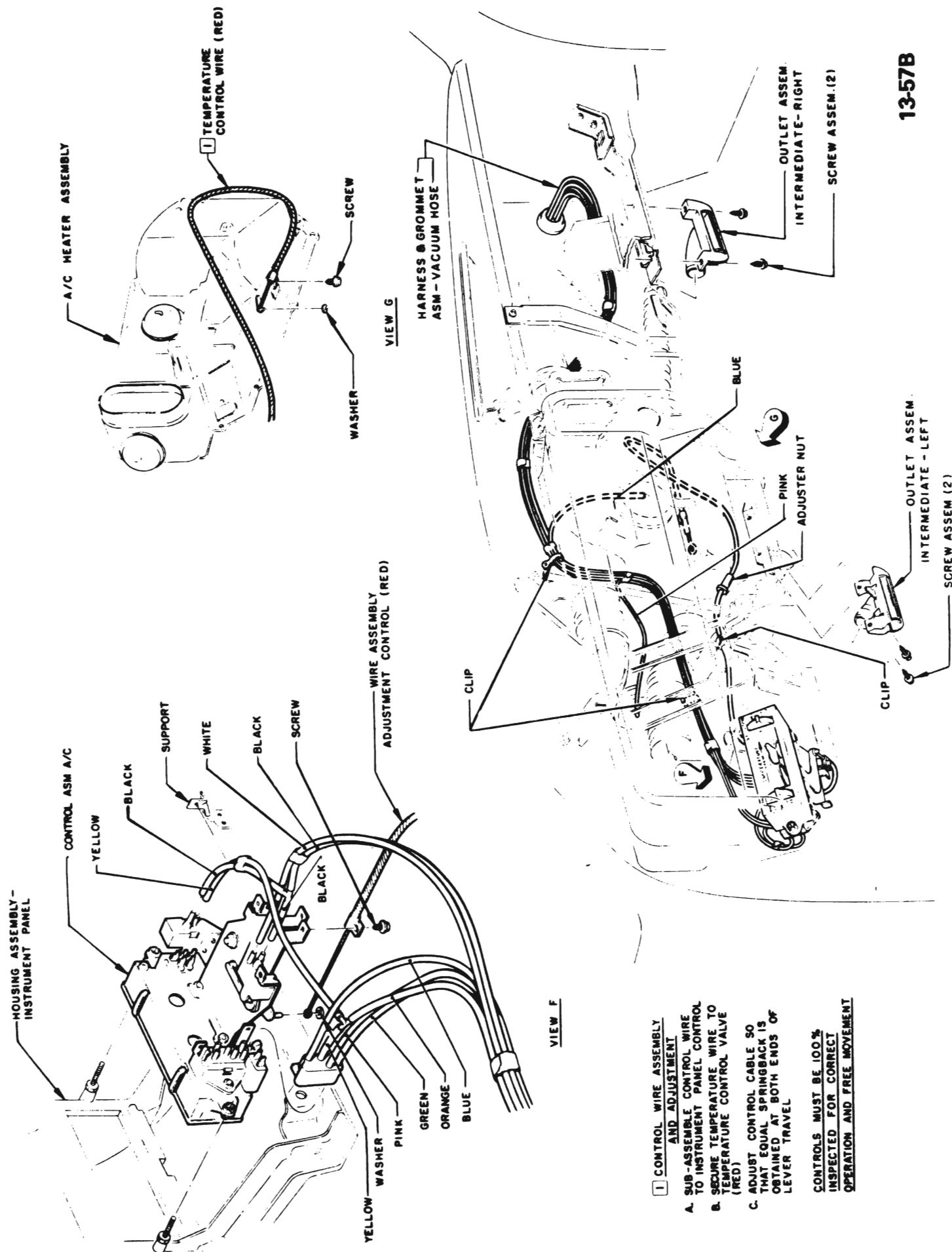

- 1** CONTROL WIRE ASSEMBLY AND ADJUSTMENT
- A. SUB-ASSEMBLE CONTROL WIRE TO INSTRUMENT PANEL CONTROL
- B. SECURE TEMPERATURE WIRE TO TEMPERATURE CONTROL VALVE (RED)
- C. ADJUST CONTROL CABLE SO THAT EQUAL SPRINGBACK IS OBTAINED AT BOTH ENDS OF LEVER TRAVEL
- CONTROLS MUST BE 100% INSPECTED FOR CORRECT OPERATION AND FREE MOVEMENT

13-57B

Figure 13-3 45-46-48000 Series Control Wire and Vacuum Hose Installation

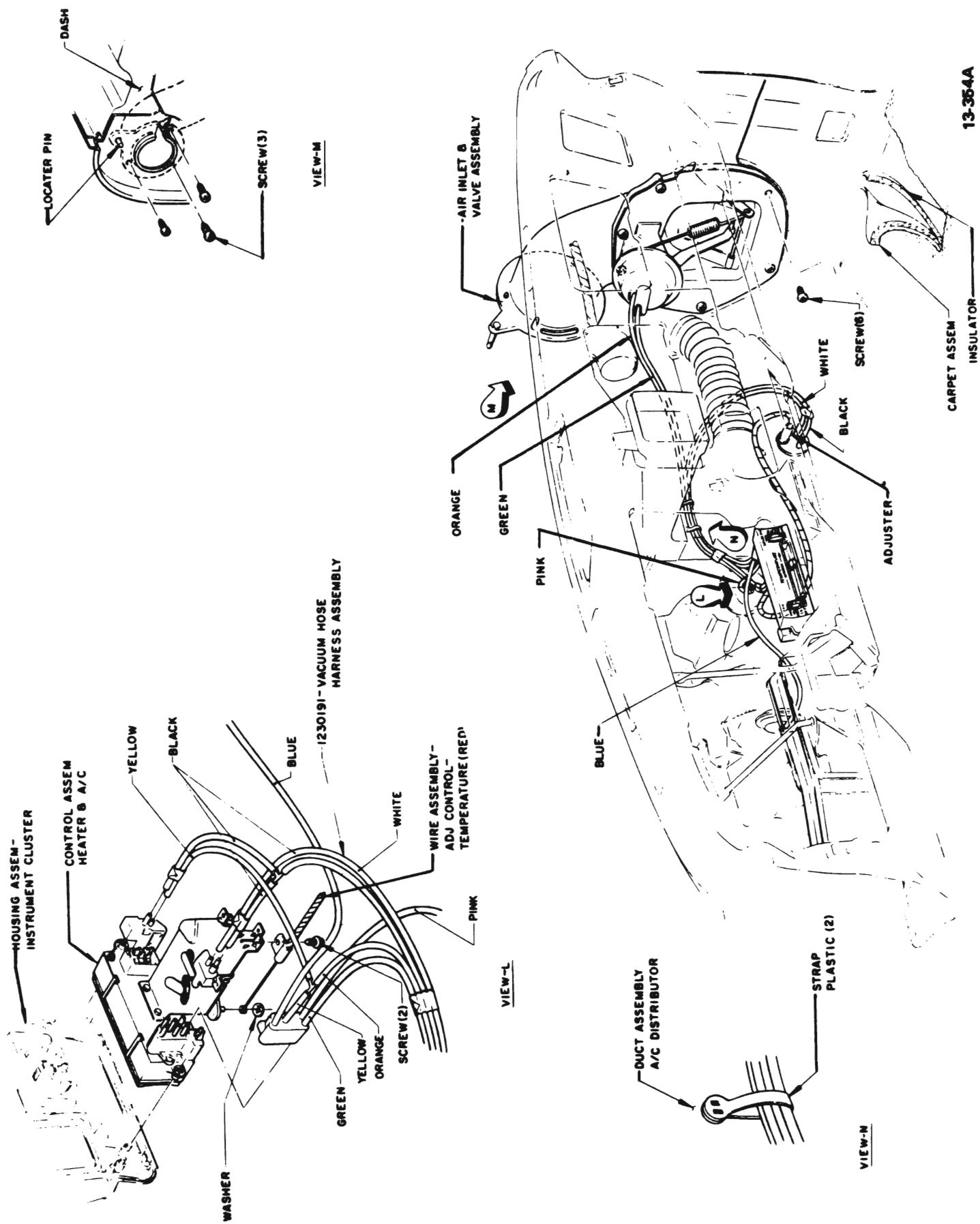

Figure 13-4 49000 Series Control Wire and Vacuum Hose Installation

13-2 ADJUSTMENT OF TEMPERATURE LEVER AND TEMPERATURE DOOR

The control cable should be adjusted when the recommended equal springback is not obtained at both ends of lever travel. This adjustment should also be made when the air conditioner-heater assembly has been removed or when the temperature door does not properly regulate the mixing of, or blocking off of heated air.

To adjust, position the TEMPERATURE lever to extreme left and rotate the control cable adjuster nut until equal springback is obtained at both ends of lever travel. 43-44000 Series see Figure 13-2, 45-46-48000 Series see Figure 13-3, 49000 Series see Figure 13-4.

13-3 ADJUSTMENT OF OUTSIDE AIR INLET DOOR

The linkage between the outside air inlet door and the vacuum diaphragm on the air inlet and valve assembly may be adjusted to insure full closing of the air door.

To adjust, remove shroud side foundation. Remove vacuum hoses and loosen linkage and allow spring to close door fully, then resecure linkage, install hoses and install shroud side foundation.

DIVISION II

DESCRIPTION AND OPERATION

13-8 GENERAL DESCRIPTION OF SYSTEM

The heater-air conditioner system is a series type in which the cooling unit and heating unit are so arranged that the air flows through both units. With an arrangement of this type it is possible to simultaneously control both the air conditioning and heating of the air in the

car. Thus the air may be cooled, heated or both cooled and reheated.

The following description of the heater-air conditioner system is divided into five areas: (1) a description of the route air takes as it flows through the system during various modes of operation, (2) how the doors (which regulate the flow of air) operate and the sequence in which they operate, (3) the theory behind obtaining hot air from the system, (4) the theory of how the system cools the air, and (5) a description of the function and purpose of each component in the air conditioning refrigeration circuit.

13-9 DESCRIPTION OF AIR FLOW THRU SYSTEM

The following description of the route the air takes as it flows thru the system during various modes of operation is divided into four parts; air flow during air conditioning mode of operation, air flow during heating mode, air flow during defrosting mode and air flow during simultaneous air conditioning and reheating modes of operation.

a. Air Flow During Air Conditioning Mode of Operation

During normal mode of operation of the air conditioner, the FAN switch (see Figure 13-5) is set at any of the four positions away from the "OFF" position. The TEMPERATURE lever will be positioned fully to the left. The SELECTOR switch will be positioned to "A/C".

Under these conditions the air flows into the system thru the opening in front of the windshield into the plenum chamber. Moving of the FAN switch to one of the four positions away from the "OFF" position opens the main vacuum switch and applies vacuum to recirculated air port of the outside-recirculated air door diaphragm causing it to partially open. Placing the SELECTOR switch in "A/C"

position applies vacuum to outside air port of outside-recirculated air door diaphragm. When vacuum is applied to both ports of the diaphragm the air door fully opens. 43-44000 Series see Figure 13-6, 45-46-48000 Series see Figure 13-10, 49000 Series see Figure 13-14.

The air now flows from the plenum chamber into the blower air inlet assembly. From here the air flows to the evaporator-blower assembly. Because the TEMPERATURE lever is fully to the left, the temperature door is closed blocking air flow thru the heater core. Consequently the cooled air flows past the normally open heater-air conditioner mode door and out to the air conditioner outlets. The above described air flow also applies to "VENT" mode of operation, the only difference being that the compressor does not operate in "VENT".

During recirculate mode of operation the SELECTOR switch is in "REC" position. The air flow is the same as in "A/C" except that no vacuum is applied to outside air port of the outside recirculated air door diaphragm. The effect of this is to cause the air door to only partially open thereby causing the system to draw some of its air supply from inside the car. 43-44000 Series see Figure 13-7, 45-46-48000 Series see Figure 13-11, 49000 Series see Figure 13-15. This has an added cooling effect because the already cooled air from inside the car can now be recirculated and further cooled.

b. Air Flow During Heater Mode of Operation

For operation of the heater portion of the system the controls are set as follows: FAN switch in one of four positions away from "OFF" position, TEMPERATURE lever positioned to "WARM", and SELECTOR switch positioned to "HTR". The FAN switch, being away from the "OFF" position, permits vacuum to flow to the recirculated air port of the outside-recirculated diaphragm

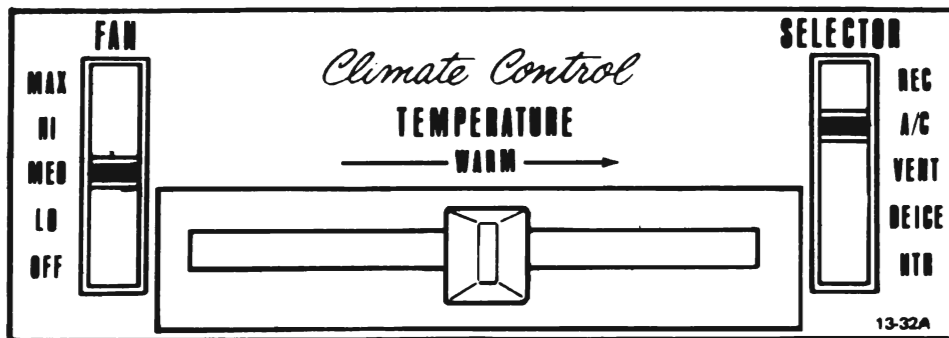

Figure 13-5 Instrument Panel Control Assembly

thereby causing the air door to partially open. The SELECTOR switch being positioned to "HTR" position permits vacuum to flow to the outside air port of the outside-recirculated air door diaphragm thereby causing the air door to open to its full extent. In addition vacuum is also applied to the heater-air conditioner mode door diaphragm, and the vacuum vents on 43-44 and 49000 series models. The effect of this is that the diaphragm pulls its related air door closed. 43-44000 Series see Figure 13-8, 45-46-48000 Series see Figure 13-12, 49000 Series see Figure 13-16.

The outside air flows as before into the plenum chamber, down into the blower and air inlet assembly thru the evaporator core, and then into the heater assembly. At this point the air flow divides (according to the opening of the temperature door) and some of it flows thru the heater core and then remixes with the non-heated air. Because the heater-air conditioner mode door is closed, air flow to the air conditioner outlets is blocked and air is thereby forced out the heater outlets.

c. Air Flow For Defroster Mode of Operation

The air flow and position of the controls is very similar to the conditions of the system during heater mode of operation with the exception that the SELECTOR switch is now positioned as required to "DEICE". This has the effect of tilting the defroster door to direct

most of the air to the defroster outlets. The position of the defroster door is controlled by a vacuum diaphragm.

d. Air Flow For Both Air Conditioning and Heater Mode of Operation

When both the air conditioner and the heater are operated simultaneously to cool, dry and then reheat the air, the controls are set as follows: FAN switch in one of four positions away from "OFF" position, TEMPERATURE lever positioned as desired toward "WARM", and SELECTOR switch positioned to "A/C". The effect of this setting of the controls will be to position the air doors to allow air flow through both evaporator and heater core. 43-44000 Series see Figure 13-9, 45-46-48000 Series see Figure 13-13, 49000 Series see Figure 13-17.

The air flow is from the plenum chamber, into the blower and air inlet assembly, and then thru the evaporator core. The air at this point divides according to the opening of the temperature door and some of it flows thru the hot heater core. Then the heated air remixes with the cooled air and is channeled to the air conditioner outlets. Vacuum is applied to both ports of the outside-recirculated air door diaphragm to cause the air door to fully open permitting only outside (no recirculated) air into the system.

13-10 OPERATION OF INSTRUMENT PANEL CONTROLS

All the controls for regulation of the heater-air conditioner system are located on the instrument panel control assembly. See Figure 13-5. They operate the system as follows:

a. FAN Switch

FAN This switch operates the heater-air conditioner blower motor. When this switch is moved from one extreme to the other, four positions will be felt. Moving from "OFF", the 1st detent will provide low blower speed. The second, third and fourth detents respectively provide medium, high and maximum blower speeds.

The FAN switch is mechanically linked to the master vacuum switch. Whenever the FAN switch is away from the "OFF" position, vacuum is applied to recirculated port of the outside-recirculated air door diaphragm via this vacuum switch and the door is partially opened.

b. TEMPERATURE Lever

When this lever is positioned fully to left, no vacuum is applied to the diaphragm of the water valve. Movement of the lever to the right applies vacuum to the diaphragm of the water valve and coolant from the engine is circulated thru the heater core. In addition, movement of the lever to the right opens the temperature door via a control cable. Regardless of the position of the SELECTOR switch (REC, A/C, VENT, DEICE, or HTR) the air flow will be warmed in proportion to TEMPERATURE lever position.

NOTE: Cars equipped with the L-6 engine are not equipped with a water valve. Therefore, water will flow through the heater core at all times.

c. SELECTOR Switch

This switch operates the outside-recirculated air door, the heater-air

conditioner mode door, and the vacuum deroster door. In addition, the switch is mechanically linked to the compressor clutch switch. Movement of the switch actuates these components in the following sequence.

"REC" - In this position the compressor clutch switch is closed completing half the circuit to the compressor clutch (the fan switch must be away from "OFF" before the compressor clutch will be energized).

"A/C" - This position maintains the clutch compressor switch closed and applies vacuum to the outside air port of the outside-recirculated air door diaphragm. With vacuum applied to both ports of this vacuum diaphragm, (vacuum is also being applied by the FAN switch being on) the outside-recirculated air door opens completely thereby drawing on only outside air and blocking off the recirculated air supply.

"VENT" In this position the compressor clutch control switch is open thereby disrupting half the electrical circuit of the compressor clutch. If the FAN switch was closed and the air conditioning system operating, the compressor would thus be shut off. Vacuum is maintained at both the outside air and recirculated air ports of the outside-recirculated air door diaphragm. The VENT position is provided to afford the driver with uncooled outside air from the air conditioner outlets.

"DEICE" - In this position the compressor clutch control switch is open thereby disrupting half the electrical circuit of the compressor clutch. On the 45000, 46000, and 48000 series, vacuum is maintained at both the outside air and recirculated air ports of the outside-recirculated air door diaphragm. In addition vacuum is applied to the heater-air conditioner mode door diaphragm and to the defroster door diaphragm on all models but 49000 series, which are vented.

"HTR" - In this position the clutch control switch remains open and vacuum remains applied to both ports of the outside-recirculated air door diaphragm. In addition vacuum is applied to the heater-air conditioner mode door diaphragm (45000, 46000, and 48000 series only). The door changes position and blocks off air flow to air conditioner outlets and directs air flow to heater outlets.

13-II OPERATION OF HEATER PORTION OF SYSTEM

Engine heat is transmitted to the heater core by flow of coolant through the core. The flow of coolant or water through the heater core is as shown in Figure 13-18 for 43-44000 Series, Figure 13-19 for 45-46-48000 Series, or Figure 13-20 for 49000 Series. Coolant enters the lower port of the heater core and exits from the upper port. A vacuum operated water valve (all engines except L-6) which is regulated by the position of the TEMPERATURE lever, controls the flow of coolant to the heater core. When the TEMPERATURE lever is fully to the left the water valve has no vacuum applied to it - hence is closed. When the TEMPERATURE lever is moved approximately 1/3 of the travel from the left, the water valve has vacuum applied to it permitting flow of coolant. The water valve will remain fully open for the remainder of the travel of the TEMPERATURE lever.

13-12 OPERATION OF AIR CONDITIONER PORTION OF SYSTEM

The state of the refrigerant at the inlet port of the compressor is a low pressure gas. The compressor compresses the gas into a high pressure, high temperature gas (See Figure 13-26). Because of the increase in pressure, the heat in the gas has been concentrated and therefore is increased above the ambient (outside air) temperature. This heat in excess above the ambient tempera-

ture tends to dissipate itself. A condenser is utilized in the refrigeration circuit to provide a means whereby the heat of the refrigerant can be easily dissipated. The high pressure, high temperature (hot) gas flows through the condenser and is cooled and condensed to a high pressure liquid as it gives up its heat. From the condenser the high pressure liquid flows to the receiver-dehydrator and then to the expansion valve where the pressure is reduced and the liquid is allowed to expand in the evaporator. When the pressure is reduced the refrigerant will successively transform itself from a high pressure liquid to a low pressure liquid, and then to a low pressure gas. As the low pressure liquid expands and becomes a low pressure gas it absorbs heat. To satisfy the refrigerant demand for heat, the air passing over the evaporator gives up heat to the evaporator and in doing so, is cooled.

The low pressure gas returns to the inlet port of the compressor (the original starting point) where the cycle just described repeats itself. Although the foregoing description holds true in actual system operation, it should be qualified insofar as whenever the compressor is running, a portion of the refrigerant remains in a liquid state and consequently there is a certain amount of continuous liquid flow of refrigerant and oil throughout the system at all times during the refrigerating cycle.

13-13 DESCRIPTION OF AIR CONDITIONING COMPONENTS

a. Compressor

The compressor is located on the right side of the engine compartment. The purpose of the unit is to draw the low pressure gas from the evaporator and compress this gas into a high temperature, high pressure gas. This action will result in the refrigerant having a higher temperature than the surrounding air.

13-10 HEATER-AIR CONDITIONING SYSTEM

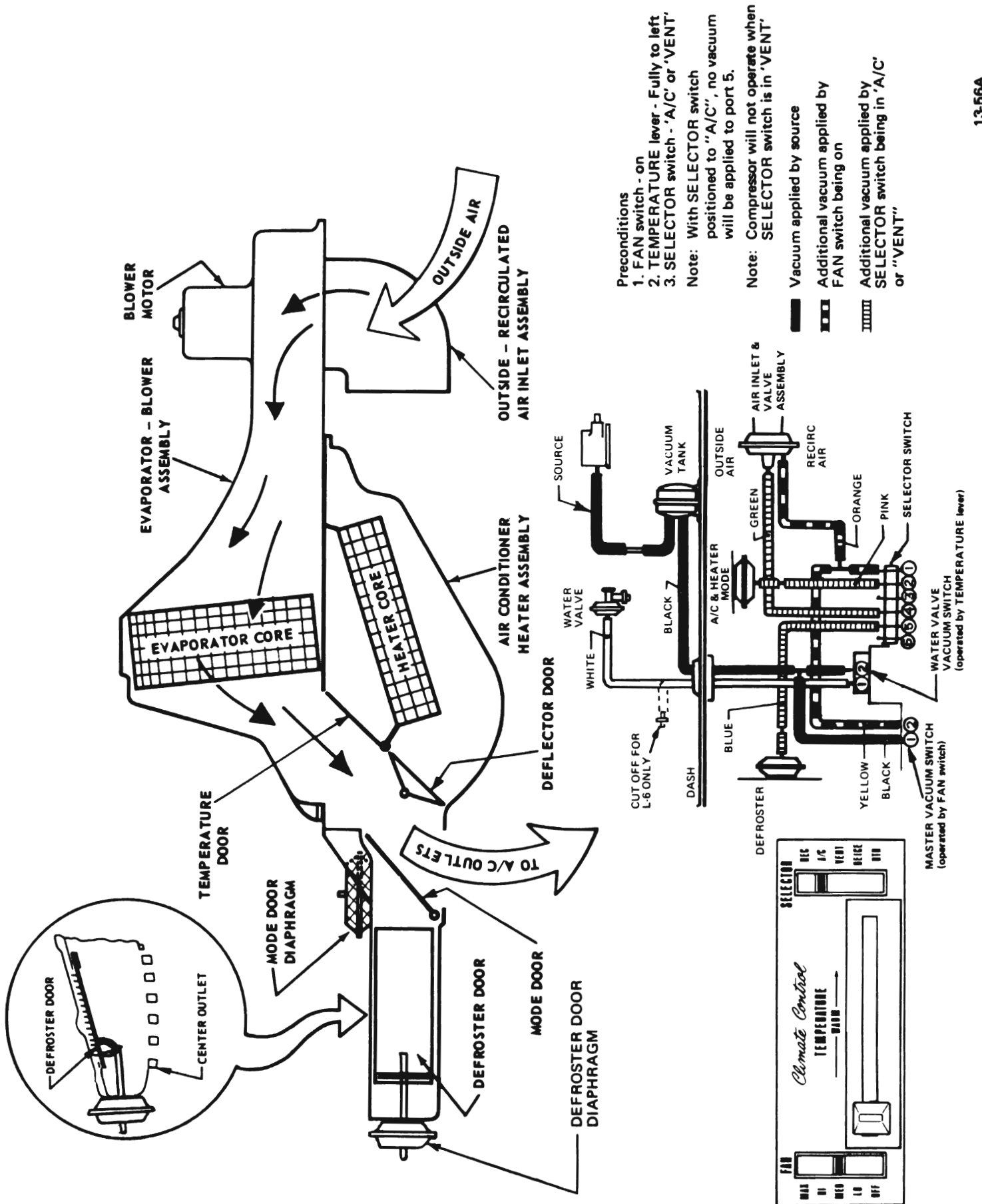

Preconditions
 1. FAN switch - on
 2. TEMPERATURE lever - Fully to left
 3. SELECTOR switch - 'A/C' or 'VENT'

Note: With SELECTOR switch positioned to "A/C", no vacuum will be applied to port 5.

Note: Compressor will not operate when SELECTOR switch is in "VENT".

Vacuum applied by source [Solid line symbol]

Additional vacuum applied by FAN switch being on [Dashed line symbol]

Additional vacuum applied by SELECTOR switch being in 'A/C' or "VENT" [Dotted line symbol]

Figure 13-6 43-44000 Series Control Position, Vacuum Circuits, and Air Flow During VENT or A/C Mode

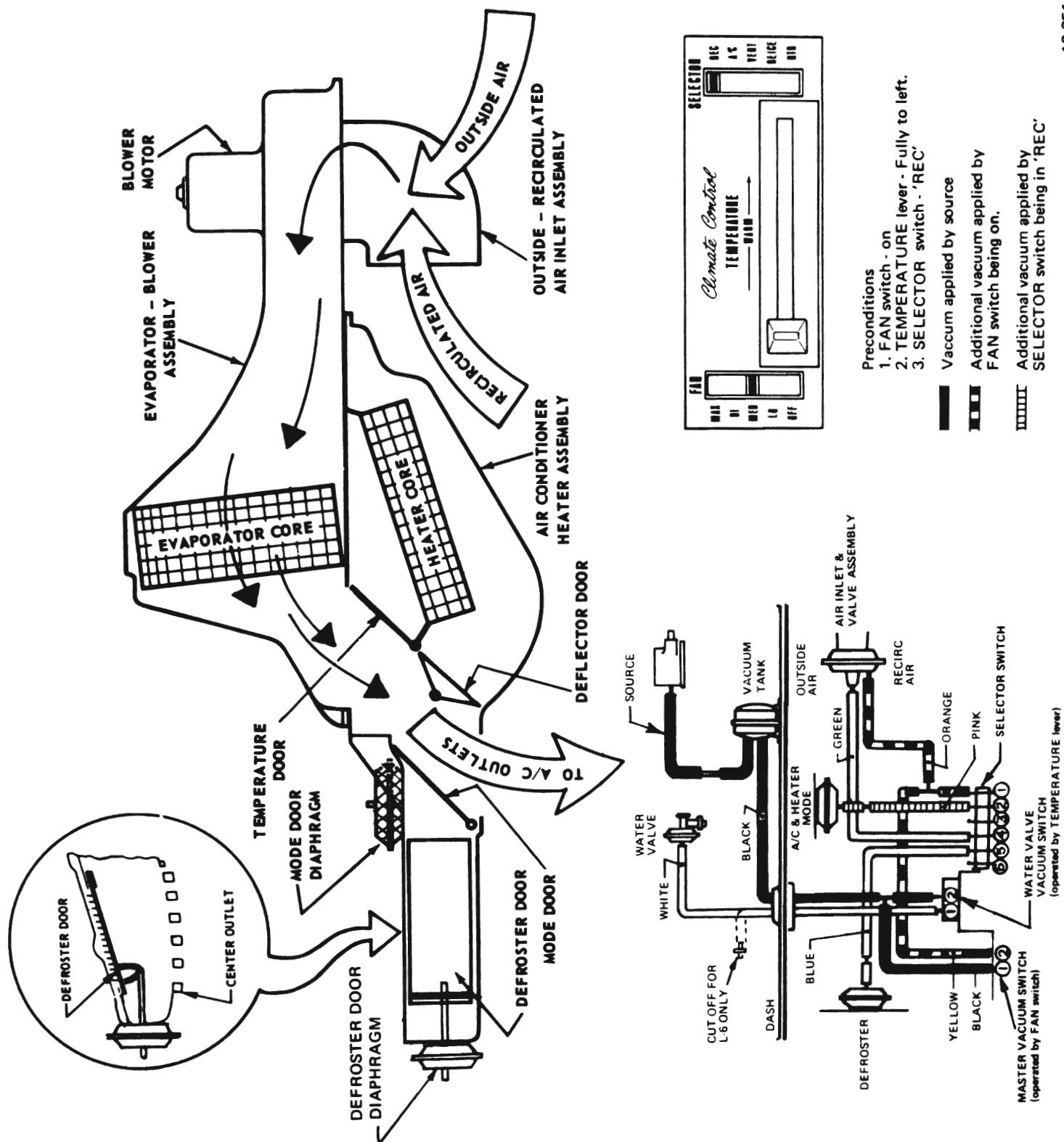

13-351A

Figure 13-7 43-44000 Series Control Position, Vacuum Circuits, and Air Flow During REC Mode

13-12 HEATER-AIR CONDITIONING SYSTEM

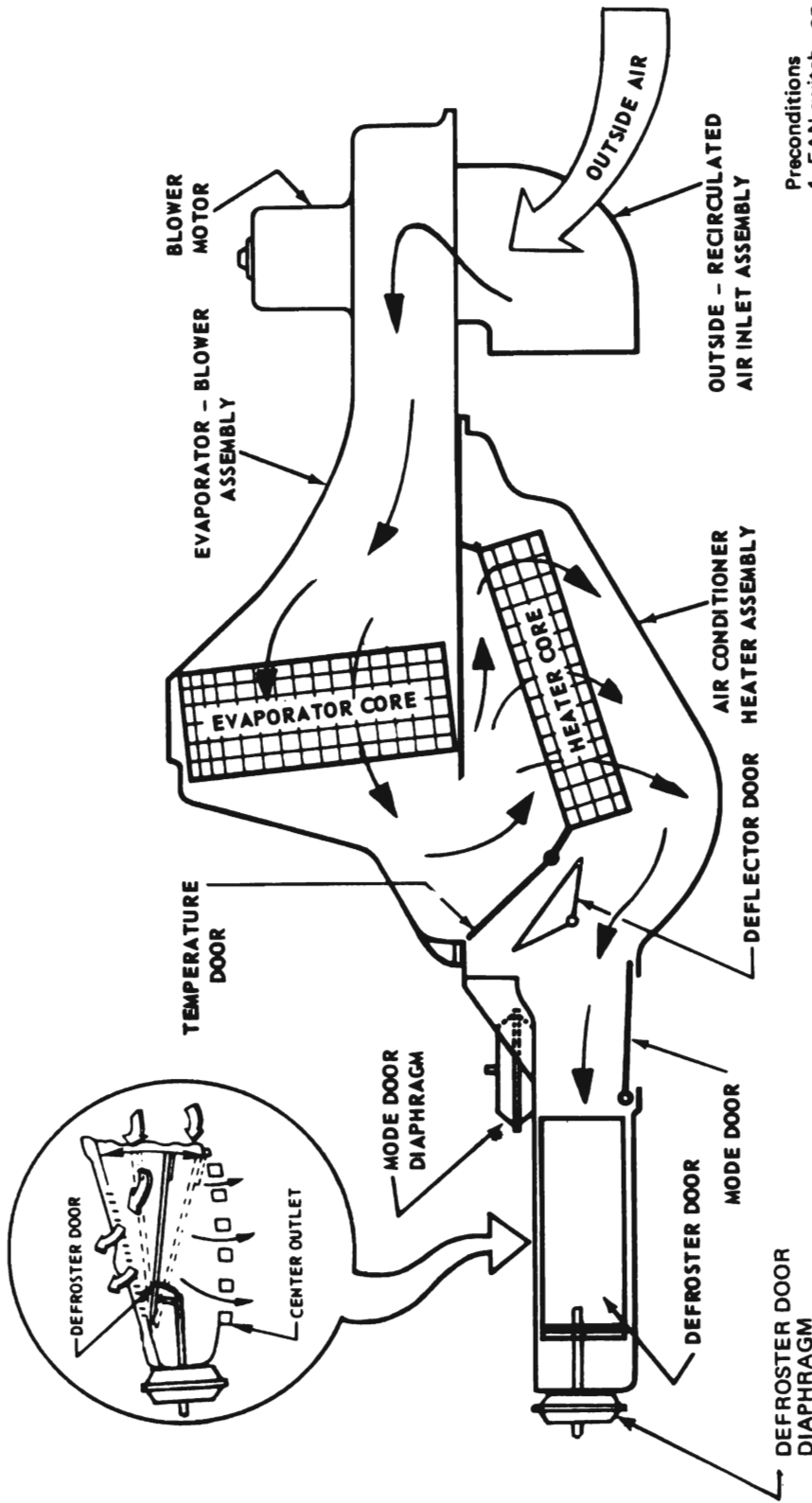

- Preconditions**
1. FAN switch - on
 2. TEMPERATURE lever - as required
 3. SELECTOR switch - 'HTR'
- Note: If SELECTOR switch is positioned to 'DEICE', vacuum would also be applied to selector switch port 5.
- Vacuum applied by source
 - ▨ Additional vacuum applied by FAN switch being on
 - ▤ Additional vacuum applied by SELECTOR switch being in 'HTR'
 - ▦ Additional vacuum applied by TEMPERATURE lever being away from 'COOL'

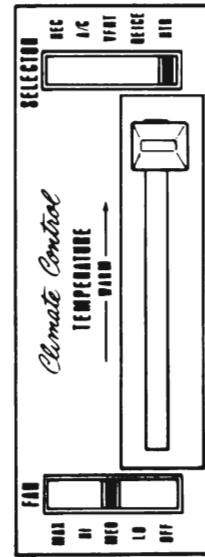
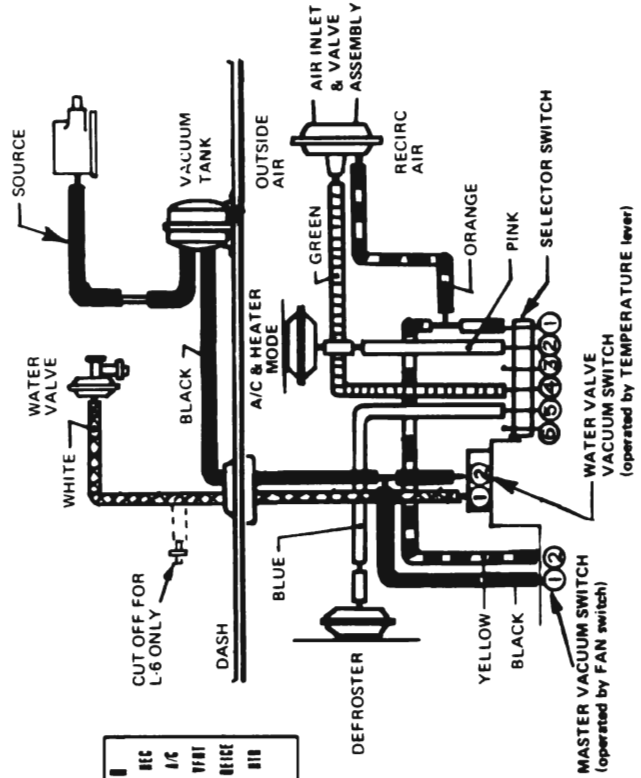

13-352A

Figure 13-8 43-44000 Series Control Position, Vacuum Circuits, and Air Flow During HTR Mode

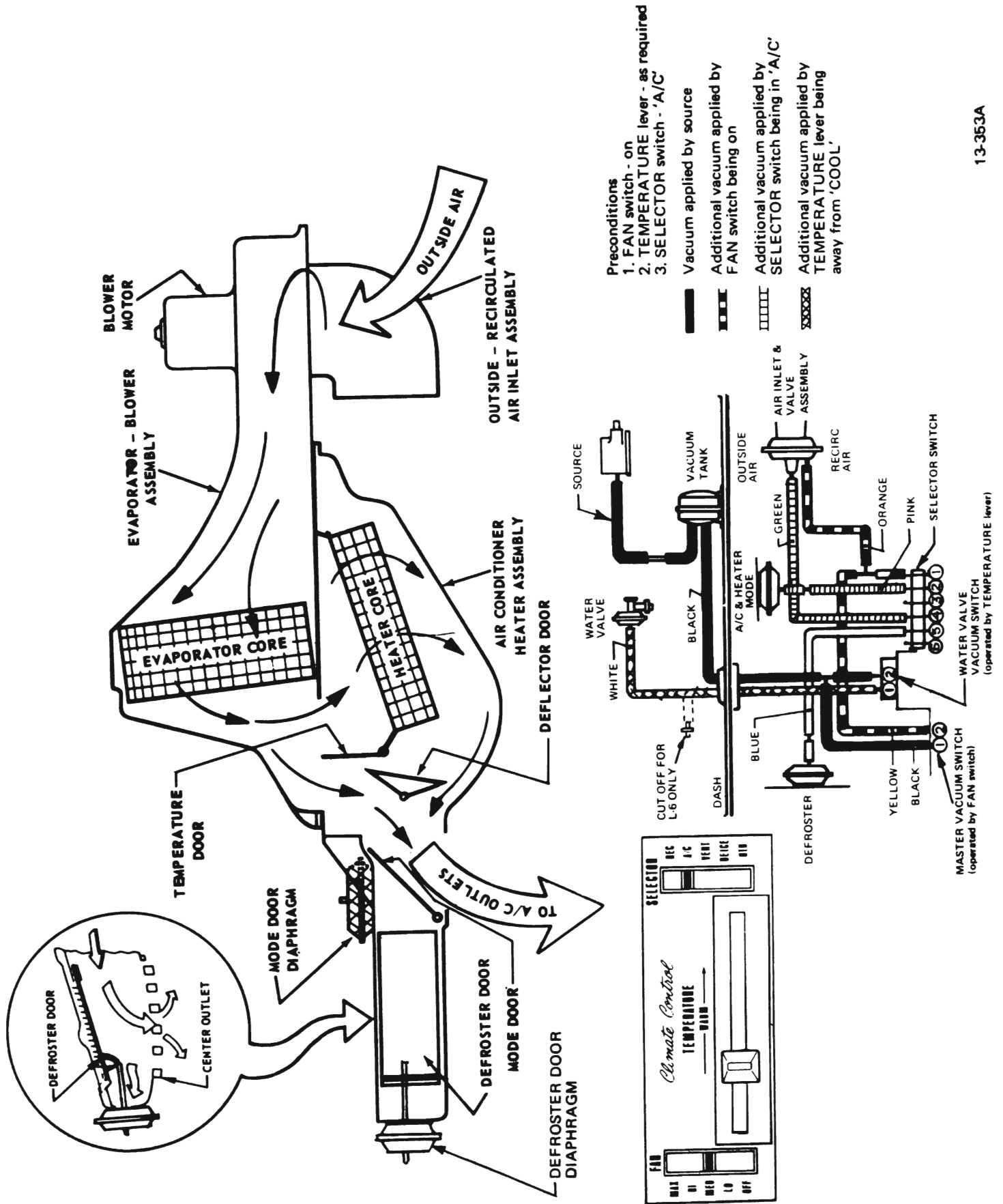
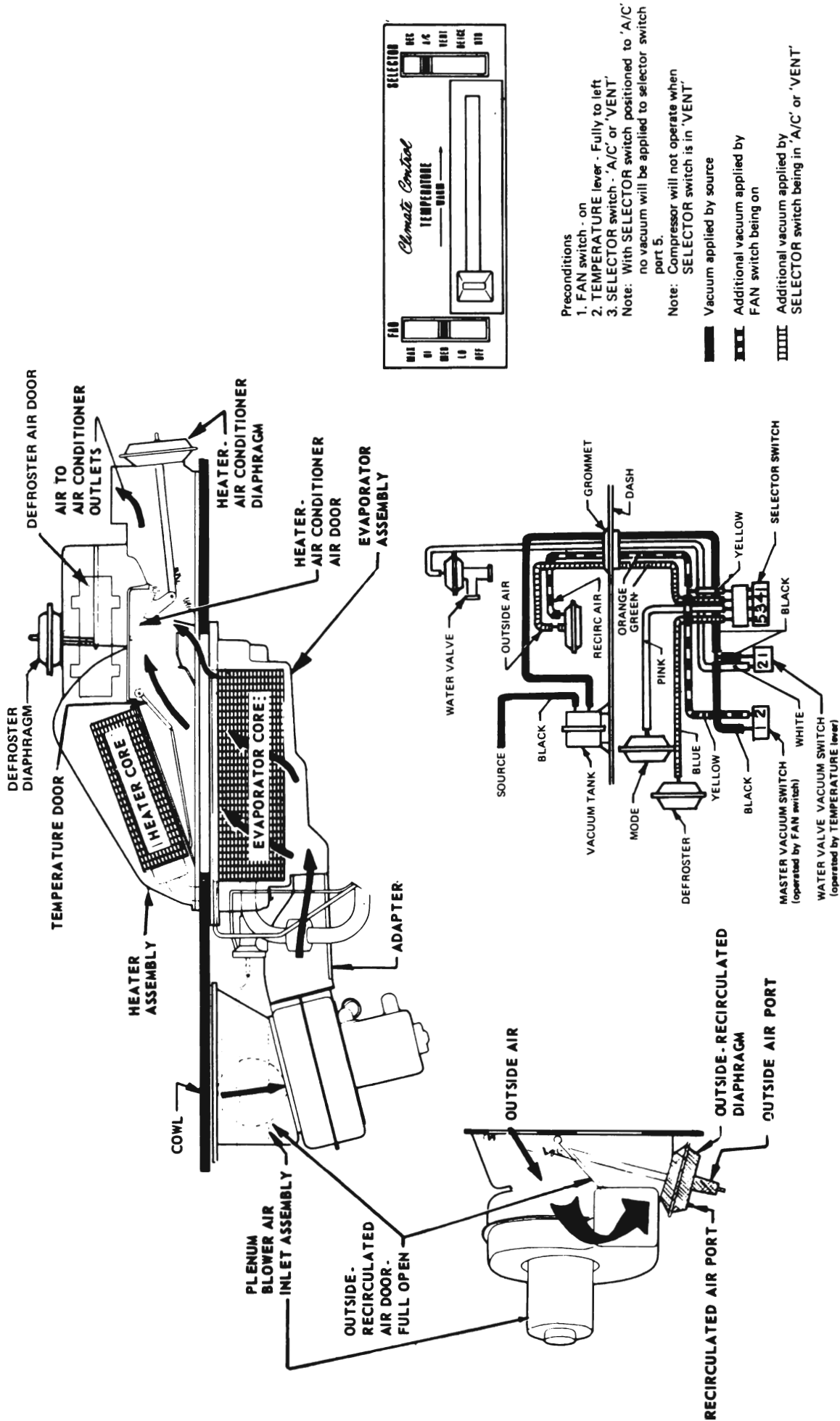

Figure 13-9 43-44000 Series Control Position, Vacuum Circuits, and Air Flow with Heater and Air Conditioner On

13-14 HEATER-AIR CONDITIONING SYSTEM



13-355A

Figure 13-10 45-46-48000 Series Control Position, Vacuum Circuits, and Air Flow During VENT or A/C Mode

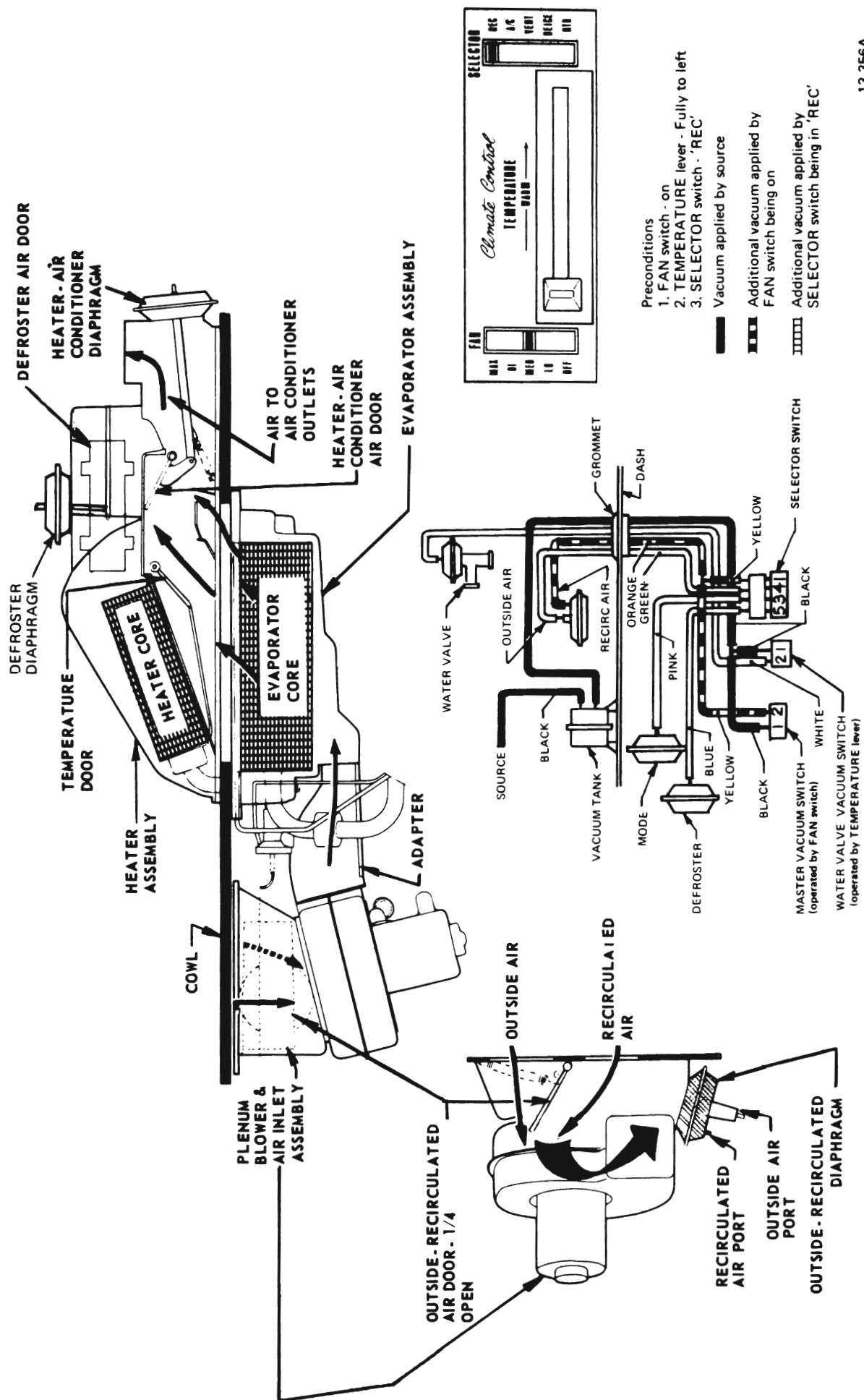

13-356A

Figure 13-11 45-46-48000 Series Control Position, Vacuum Circuits, and Air Flow During REC Mode

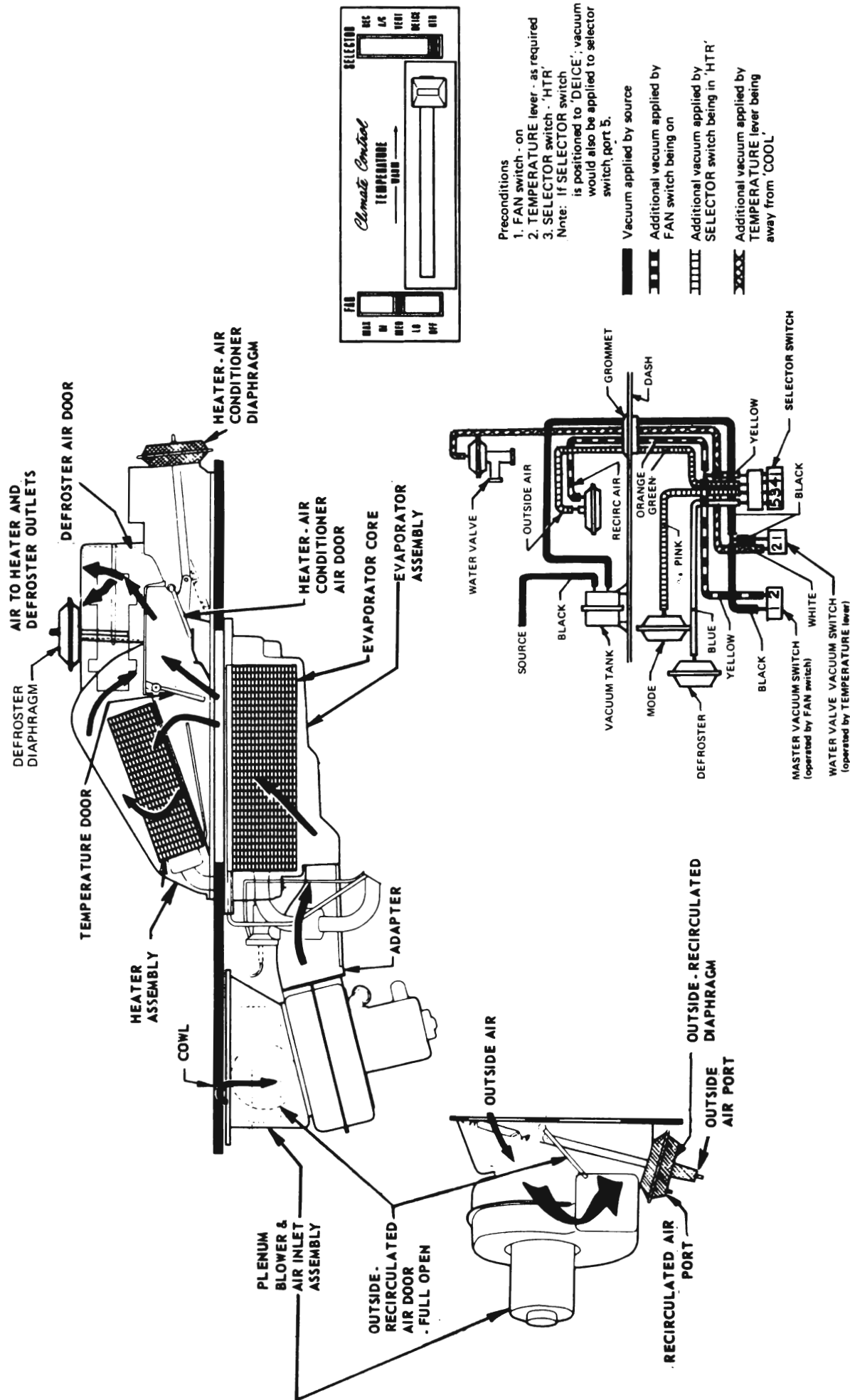

13-357A

Figure 13-12 45-46-48000 Series Control Position, Vacuum Circuits, and Air Flow During HTR Mode

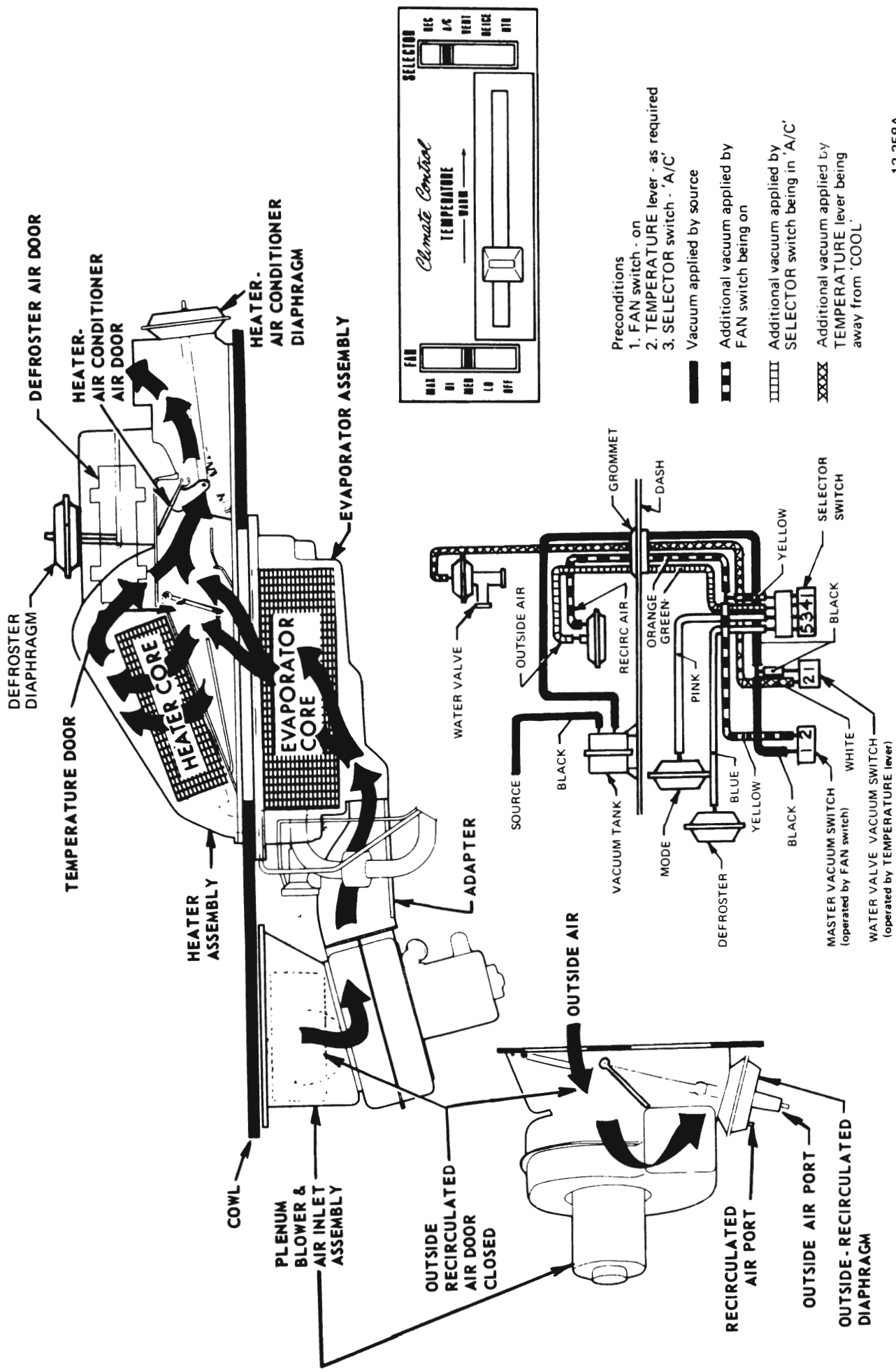

13-358A

Figure 13-13 45-46-48000 Series Control Position, Vacuum Circuits, and Air Flow with Heater and Air Conditioner On

13-18 HEATER-AIR CONDITIONING SYSTEM

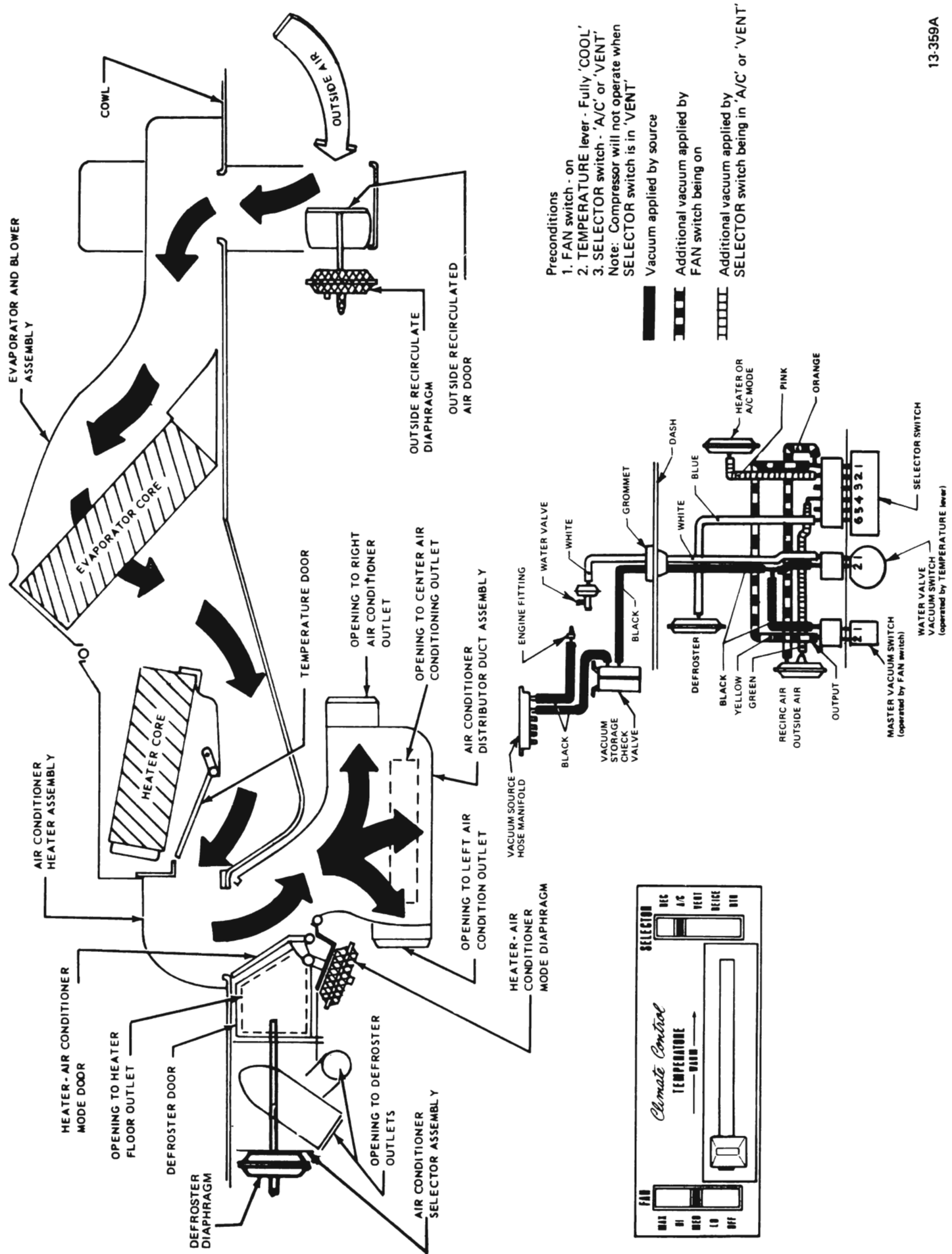

13-359A

Figure 13-14 49000 Series Control Position, Vacuum Circuits, and Air Flow During VENT or A/C Mode

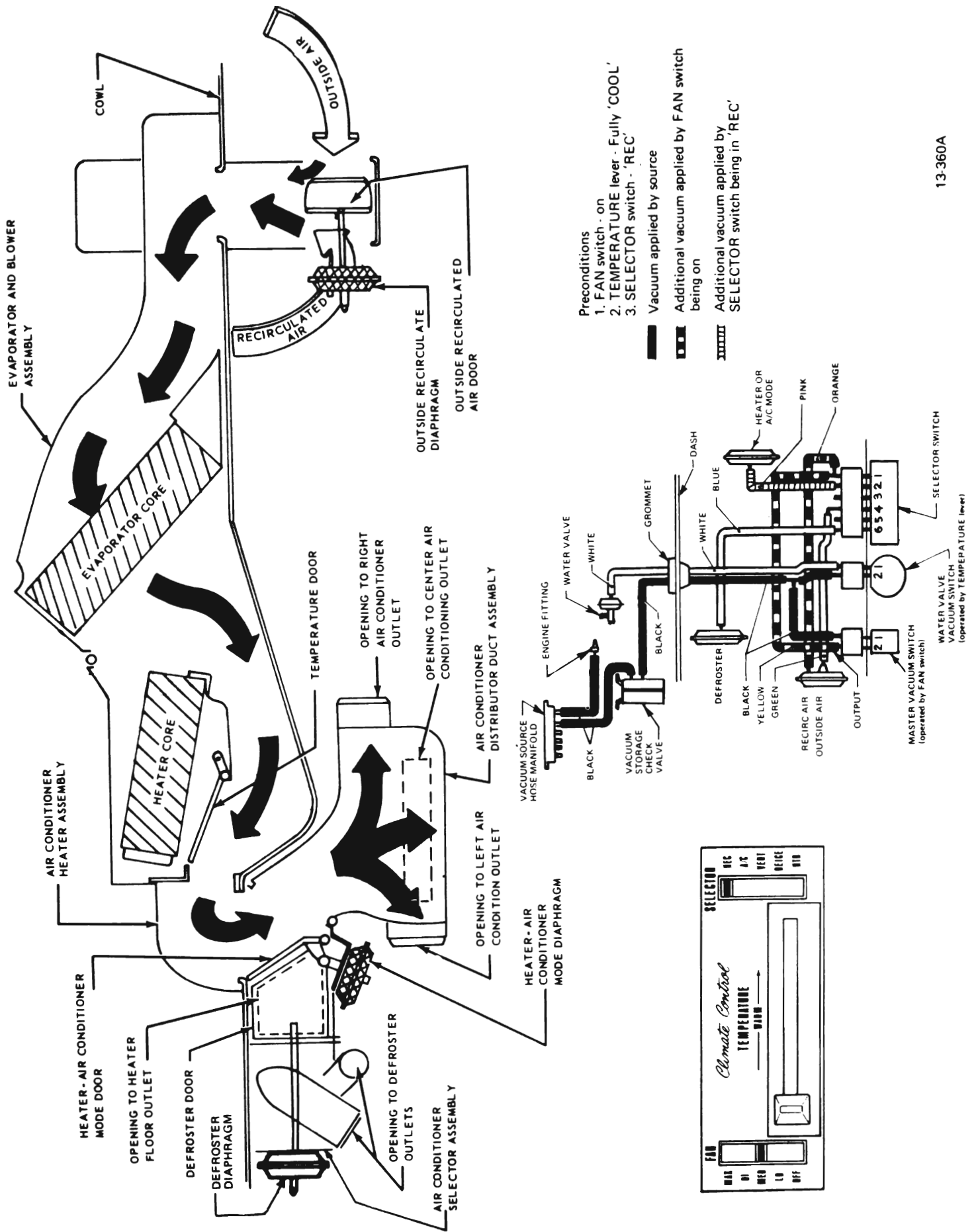

13-360A

Figure 13-15 49000 Series Control Position, Vacuum Circuits, and Air Flow During REC

13-20 HEATER-AIR CONDITIONING SYSTEM

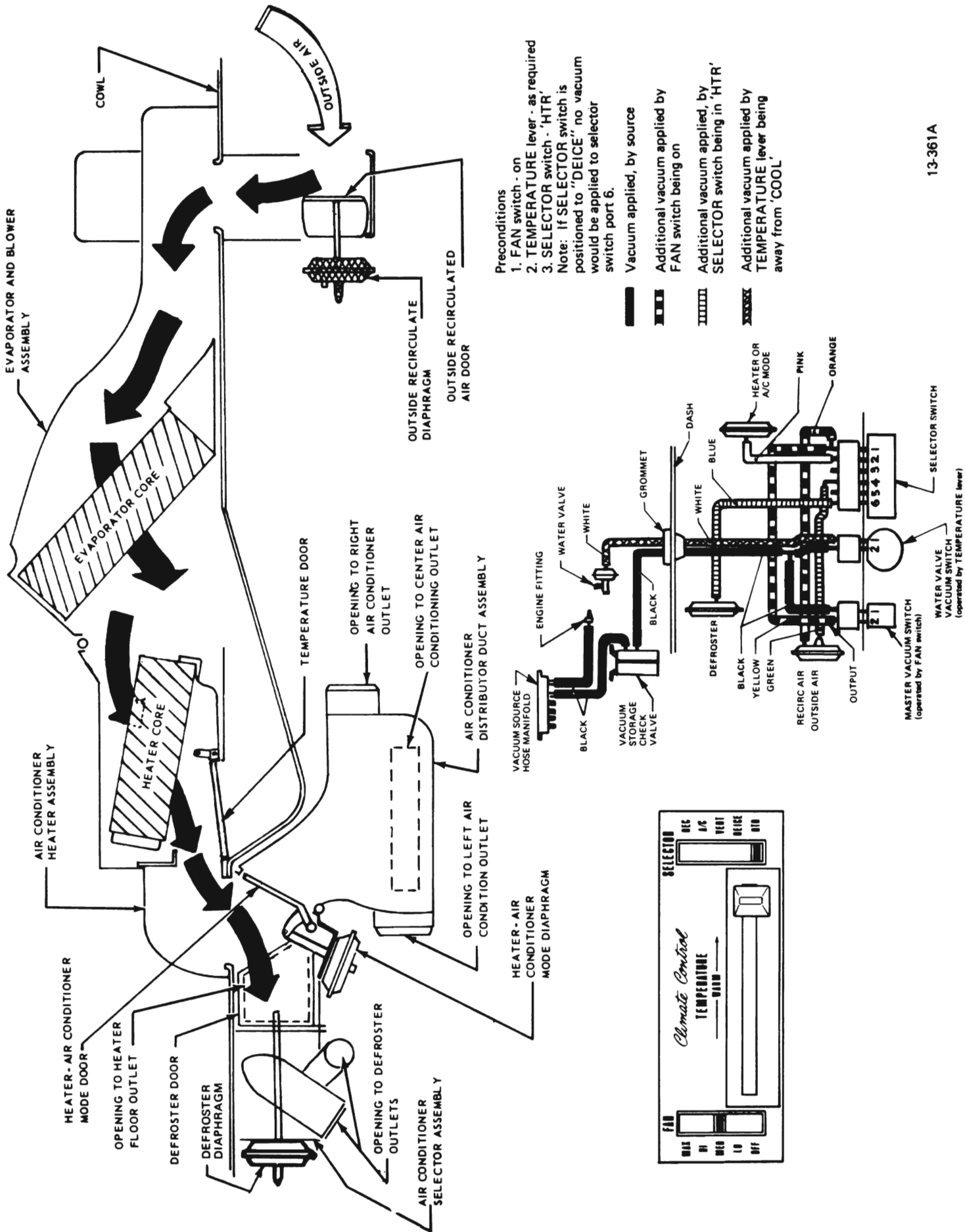

13-361A

Figure 13-16 49000 Series Control Position, Vacuum Circuits, and Air Flow During HTR Mode

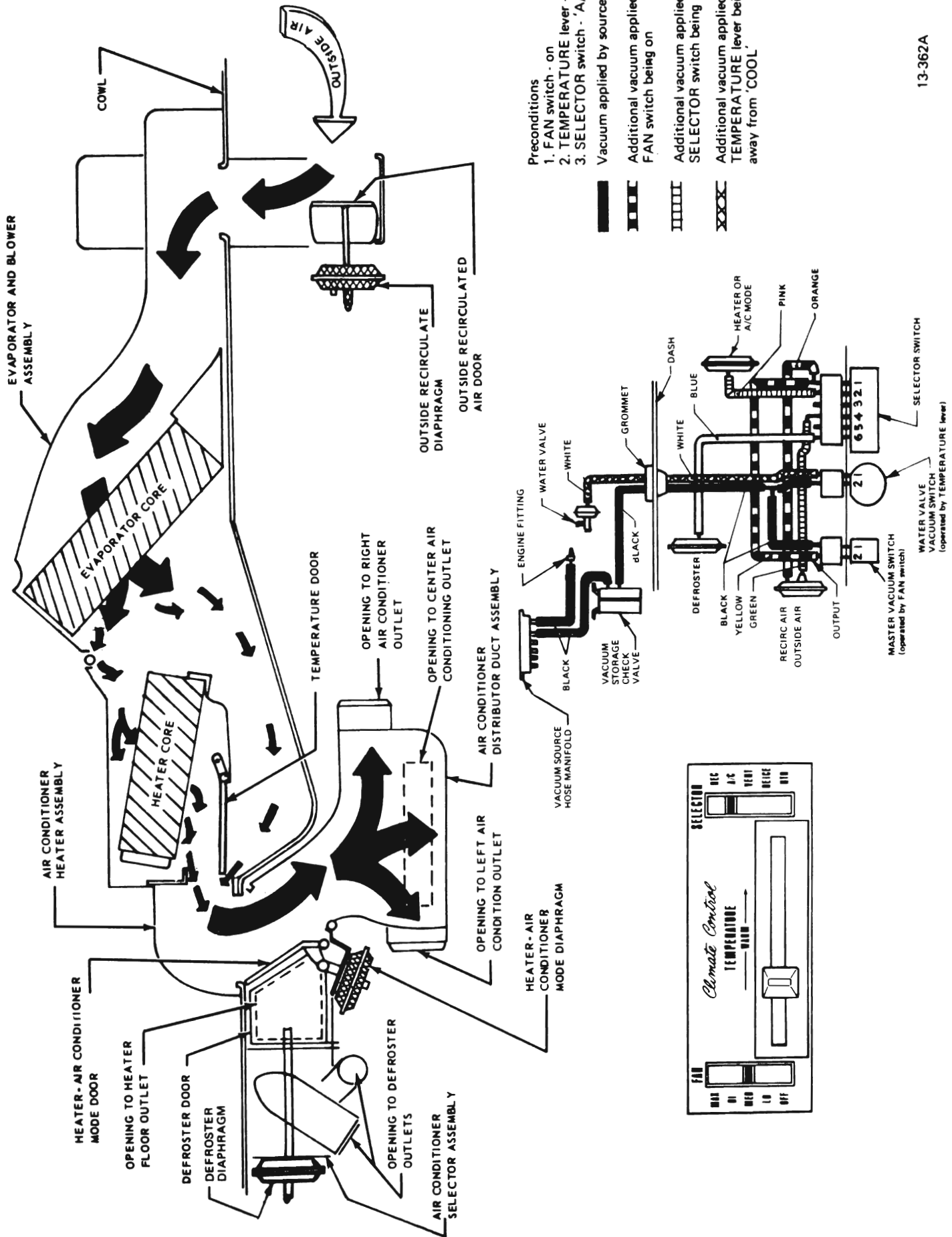

13-362A

Figure 13-17 49000 Series Control Position, Vacuum Circuits, and Air Flow with Heater and Air Conditioner On

13-22 HEATER-AIR CONDITIONING SYSTEM

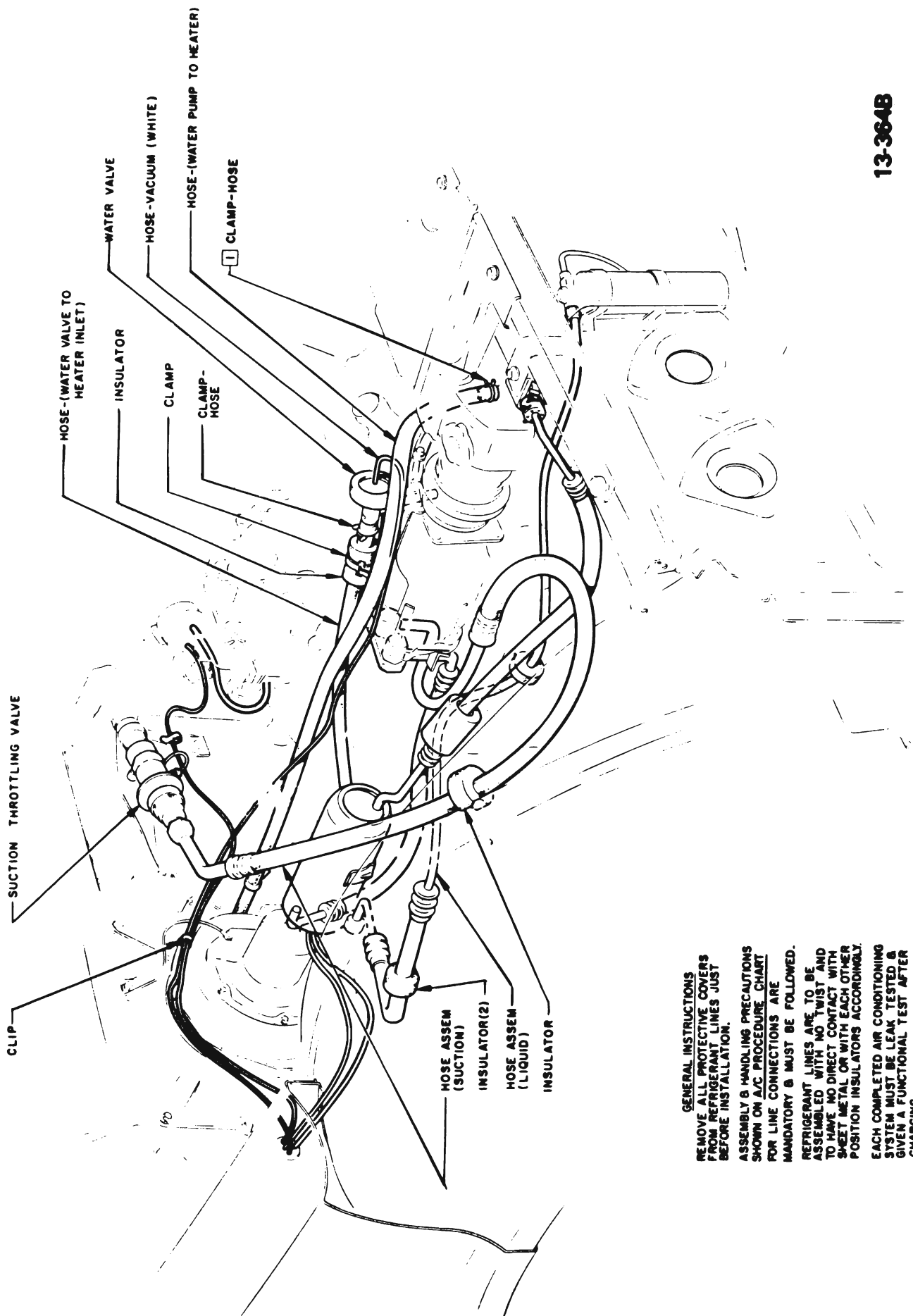

13-364B

GENERAL INSTRUCTIONS
 REMOVE ALL PROTECTIVE COVERS FROM REFRIGERANT LINES JUST BEFORE INSTALLATION.

ASSEMBLY & HANDLING PRECAUTIONS SHOWN ON A/C PROCEDURE CHART FOR LINE CONNECTIONS ARE MANDATORY & MUST BE FOLLOWED.

REFRIGERANT LINES ARE TO BE ASSEMBLED WITH NO TWIST AND TO HAVE NO DIRECT CONTACT WITH SHEET METAL OR WITH EACH OTHER POSITION INSULATORS ACCORDINGLY.

EACH COMPLETED AIR CONDITIONING SYSTEM MUST BE LEAK TESTED & GIVEN A FUNCTIONAL TEST AFTER CHARGING.

Figure 13-18 45-46-48000 Series Coolant Flow

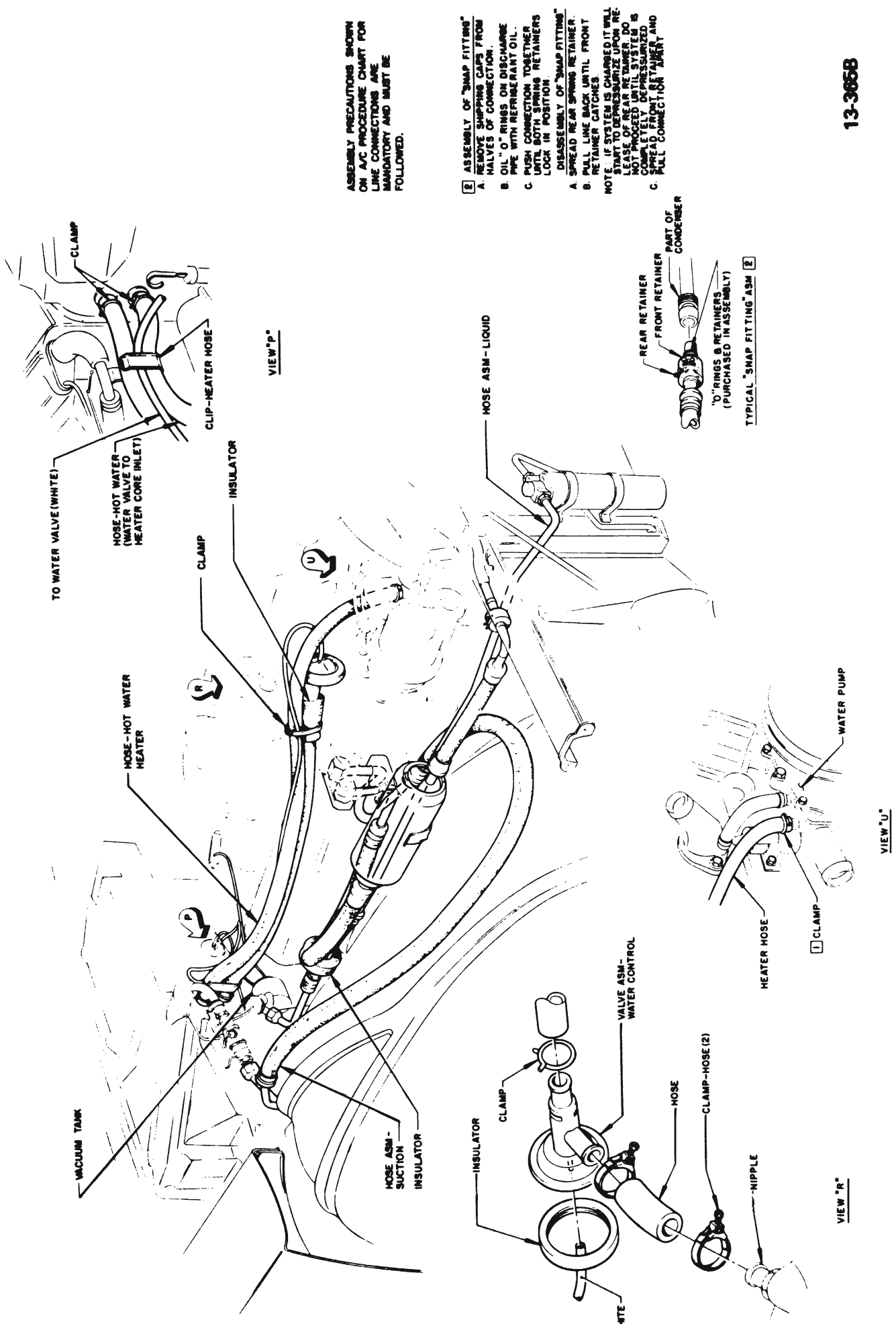

ASSEMBLY PRECAUTIONS SHOWN ON A/C PROCEDURE CHART FOR LINE CONNECTIONS ARE MANDATORY AND MUST BE FOLLOWED.

- E ASSEMBLY OF "SNAP FITTING"**
- REMOVE SHIPPING CAPS FROM HALVES OF CONNECTION.
 - OIL "D" RINGS ON DISCHARGE PIPE WITH REFRIGERANT OIL.
 - PUSH CONNECTION TOGETHER UNTIL BOTH SPRING RETAINERS LOCK IN POSITION.
- DISASSEMBLY OF "SNAP FITTING"**
- SPREAD REAR SPRING RETAINER.
 - PULL LINE BACK UNTIL FRONT RETAINER CATCHES.
- NOTE: IF SYSTEM IS CHARGED IT WILL BE NEARLY IMPOSSIBLE TO REMOVE REAR RETAINER DO NOT PROCEED UNTIL SYSTEM IS COMPLETELY DEPRESSURIZED.
- PULL FRONT RETAINER AND SPREAD FRONT RETAINER AND

13-365B

Figure 13-19 49000 Series Coolant Flow

13-24 HEATER-AIR CONDITIONING SYSTEM

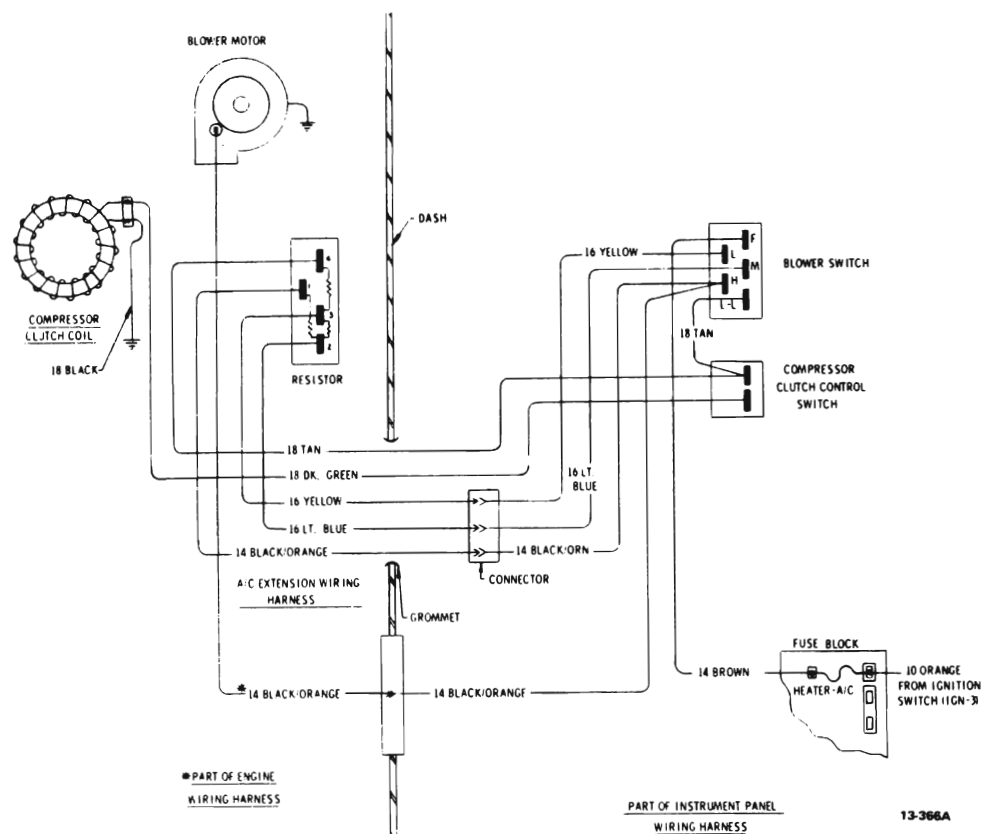

Figure 13-23 43-44000 Series Heater-Air Conditioner Wiring

The compressor is of basic double action piston design. Three horizontal double acting pistons make up a six cylinder compressor (see Figure 13-27). The pistons operate in 1-1/2 inch bore and have a 1-1/8 inch stroke. A swash plate keyed to the shaft drives the pistons. The shaft is belt driven through a magnetic clutch and pulley arrangement. An oil pump mounted at the rear of the compressor picks up oil from the bottom of the compressor and lubricates the bearings and other internal parts of the compressor.

Reed type valves at each end of the compressor open or close to control the flow of incoming and outgoing refrigerant. Two gas tight passages interconnect chambers of the front and rear heads so that there is one common suction port, and one common discharge port. The internal

parts of the compressor function as follows:

1. Suction Valve Reed Discs and Discharge Valve Plates - The two suction valve reed discs and two discharge valve plates (see Figure 13-28) operate in a similar but opposite manner. The discs are composed of three reeds and function to open when the pistons are on the intake portion of their stroke (downstroke), and close on the compression stroke. The reeds allow low pressure gas to enter the cylinders. The discharge valve plates also have three reeds, however, they function to open when the pistons are on the compression portion of their stroke (upstroke), and close on the intake stroke. High pressure gas exits from the discharge ports in the discharge valve plate. Three retainers riveted directly above the reeds on the valve plate

serve to limit the opening of the reeds on the compression stroke.

2. Front and Rear Heads - The front and rear heads (Figure 13-29) serve to channel the refrigerant into and out of the cylinders. The front head is divided into two separate passages and the rear head is divided into three separate passages. The outer passage on both the front and rear heads channels high pressure gas from the discharge valve reeds. The middle passage on both front and rear heads channels low pressure gas to the suction valve plate reeds. The inner passage on the rear head houses the oil pump inner and outer rotors. A Teflon sealing material is bonded to the sealing surfaces separating the passages in the rear head. "O" rings are used to affect a seal between the mating surfaces of the heads and the shell. The front head suction and discharge passages are connected to the suction and discharge passages of the rear head by a discharge tube and suction passage in the body of the cylinder assembly. A screen located in the suction port of the rear head prevents foreign material from entering the circuit.

3. Oil Pump - An internal tooth outer rotor and external tooth inner rotor comprise the oil pump. The pump works on the principle of a rotary type pump. Oil is drawn up from oil reservoir in underside of shell through the oil inlet tube (see Figure 13-30) and circulated through the system via a 3/16 inch diameter oil passage through the shaft center and also four 5/64 inch diameter holes drilled perpendicular to the shaft. The inner rotor is driven by the shaft.

4. Shaft and Swash Plate Assembly - The shaft and swash plate assembly (see Figure 13-27) consists of an elliptical plate positioned obliquely to the shaft. As the plate and shaft rotate, the surface of the plate moves to and fro lengthwise relative to the centerline of the shaft. This reciprocating motion is transmitted to the pistons which contact the surface of

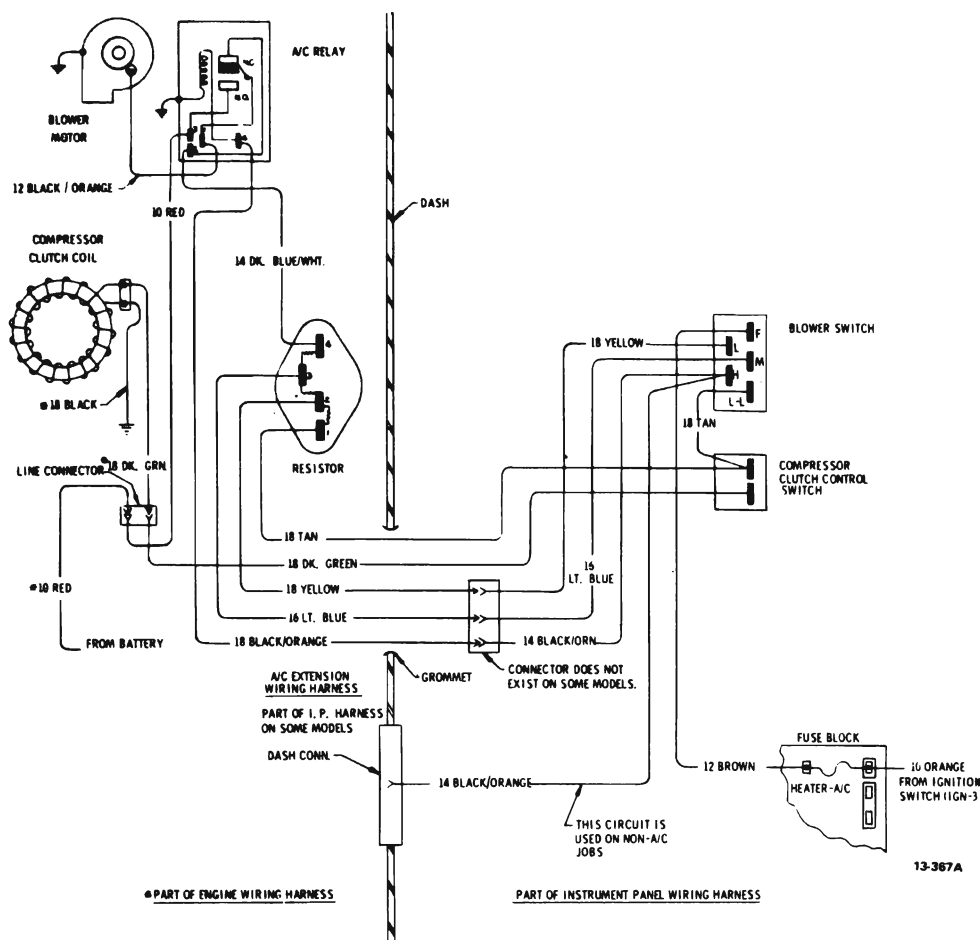

Figure 13-24 45-46-48000 Series Heater-Air Conditioner Wiring Diagrams

the swash plate. A woodruff key locks the swash plate onto the shaft. The swash plate and shaft are serviced as an assembly. The shaft is driven by a pulley when the magnetic clutch is energized. A needle thrust bearing and a mainshaft bearing support the shaft horizontally and vertically.

5. Needle Thrust Bearing and Races - Two needle thrust bearings, each "sandwiched" between two races are located on either side of the swash plate hub. The front needle thrust bearing and races provide 0.010" to 0.015" clearance between the top of the pistons and the rear side of the front suction valve reed disc (see Figure 13-31). The rear needle thrust bearings and races provide 0.0005" to 0.0015" clearance between the hub of the swash plate and the rear hub

of the rear cylinder. Races of various thicknesses are provided for service replacement to achieve required clearances when rebuilding units.

6. Cylinder Assembly and Pistons - The cylinder assembly (front cylinder and rear cylinder) is serviced only as a matched set. Alignment of the two halves is maintained by two dowel (locater) pins.

The double ended pistons are made of cast aluminum. There are two grooves on each end of the piston. The outer grooves will receive a piston ring. The inner grooves act as oil scraper grooves to collect any excess oil. Two oil return holes are drilled into the scraper grooves and allow oil to drain back into the reservoir.

7. Shoe Discs - The shoe discs are made of bronze and act as a bearing between the ball and the swash plate. An oil circulation hole is provided through the center of each shoe for lubrication purposes. These shoes are of various thicknesses and are provided in 0.0005 inch increments. Ten sizes are available for service replacement. A basic "zero" shoe size is available for preliminary gauging procedures when rebuilding a cylinder assembly.

8. Suction Passage Cover - The suction passage cover fits over a suction passage (see Figure 13-32) in the body of the cylinder assembly. Low pressure vapor flows from the suction port through the suction passage in the cylinder assembly, and into the suction cavity of the front head.

9. Discharge Tube - The discharge tube is used to connect the discharge cavity in the front head with the discharge cavity in the rear head. High pressure vapor discharge is channeled via the tube to the discharge cavity and port. A slightly modified discharge tube is provided to be used as a service replacement (see Figure 13-33). The service replacement tube has a reduced end and a built up shoulder to accommodate an "O" ring and bushing. These added parts achieve the necessary sealing of the high pressure vapor within the compressor.

10. Pressure Relief Valve - The purpose of the pressure relief valve is to prevent the discharge pressure from exceeding 440 psi. Opening of the pressure relief valve will be accompanied by a loud popping noise and the ejection of some refrigerant from the valve. If the pressure relief valve is actuated due to excessive pressures in the compressor, the cause of the malfunction should be corrected immediately. The pressure relief valve is located on the rear head of the compressor.

11. Shell and Oil Drain Screw - The shell of the compressor contains a

13-26 HEATER-AIR CONDITIONING SYSTEM

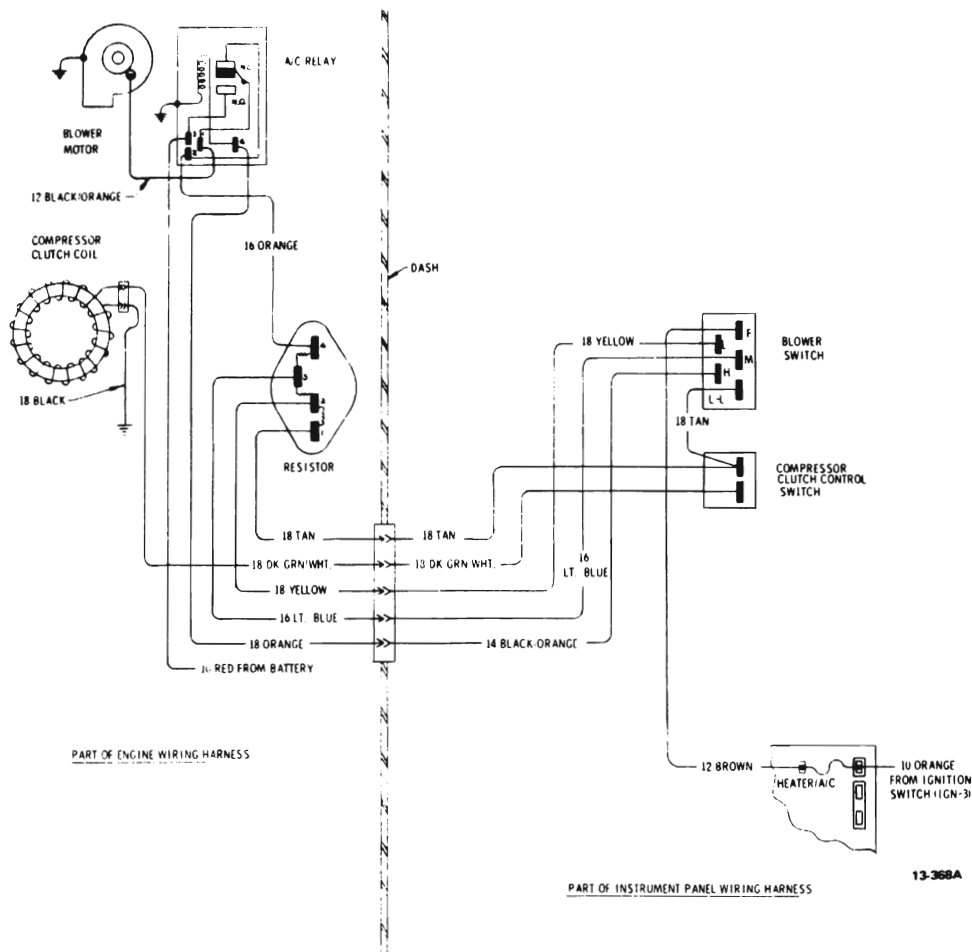

Figure 13-25 49000 Series Heater-Air Conditioner Wiring Diagrams

reservoir which furnishes a continuous supply of oil to the moving parts of the compressor. A baffle plate covers the reservoir and is tack-welded to the inside of the shell. In addition an oil drain screw and gasket are located on the side of the reservoir and are provided for draining or adding of oil to system. To add oil, compressor must be removed from car. The necessity to add oil should only be required when the system has ruptured violently and oil has been lost along with refrigerant. Under controlled conditions or slow leak conditions it is possible to lose only a small amount of oil with the refrigerant gas. The serial number, part or model number, and rating of the compressor is stamped on name plates located on top of shell.

12. Magnetic Clutch and Pulley Assembly - The magnetic clutch and pulley assembly (see Figure 13-34) together transmit power from the engine crankshaft to the compressor. The magnetic clutch is actuated when the air conditioning clutch compressor switch and the fan switch located on the instrument panel control assembly are closed. When the switches are closed, the coil sets up a magnetic field and attracts the armature plate (movable element of the clutch driven plate). The armature plate portion of the clutch driven plate moves forward and contacts the friction surface of the pulley assembly, thereby mechanically linking the compressor to the engine. The compressor will operate continuously whenever the air conditioner clutch compressor

switch and the fan switch are closed. When one or both of the switches are open the armature plate will be released due to spring tension and move away from the pulley assembly. This allows the pulley to rotate without driving the shaft. It should be noted that if the air conditioner system was in use when the engine was turned off, the armature plate may remain in contact with the pulley due to residual magnetism. When the engine is started the armature plate will separate from the pulley assembly. The coil is rated at 3.85 ohms (85°F.) and will draw 3.2 amperes at 12 volts D.C.

b. Muffler

A muffler is located on the discharge line side of the compressor. The muffler acts to reduce the characteristic pumping sound of the compressor. To further reduce compressor noise transfer through the body to the passenger compartment, a sheet of soft rubber insulation is wrapped around the outside of the muffler.

c. Condenser

The condenser which is made of aluminum is located in front of the radiator so that it receives a high volume of air flow. Air passing over the condenser absorbs the heat from the high pressure gas and causes the refrigerant to condense into a high pressure liquid.

d. Receiver - Dehydrator

The receiver-dehydrator is mounted on the front of the condenser. The purpose of the receiver-dehydrator is twofold: the unit insures a solid column of liquid refrigerant to the expansion valve at all times, and also absorbs any moisture in the system that might be present. A bag of desiccant (moisture absorbing material) is provided to absorb moisture. A sight glass (see Figure 13-35) permits visual checking of the refrigerant flow for bubbles or foam. The continuous appearance of bubbles or foam above an ambient

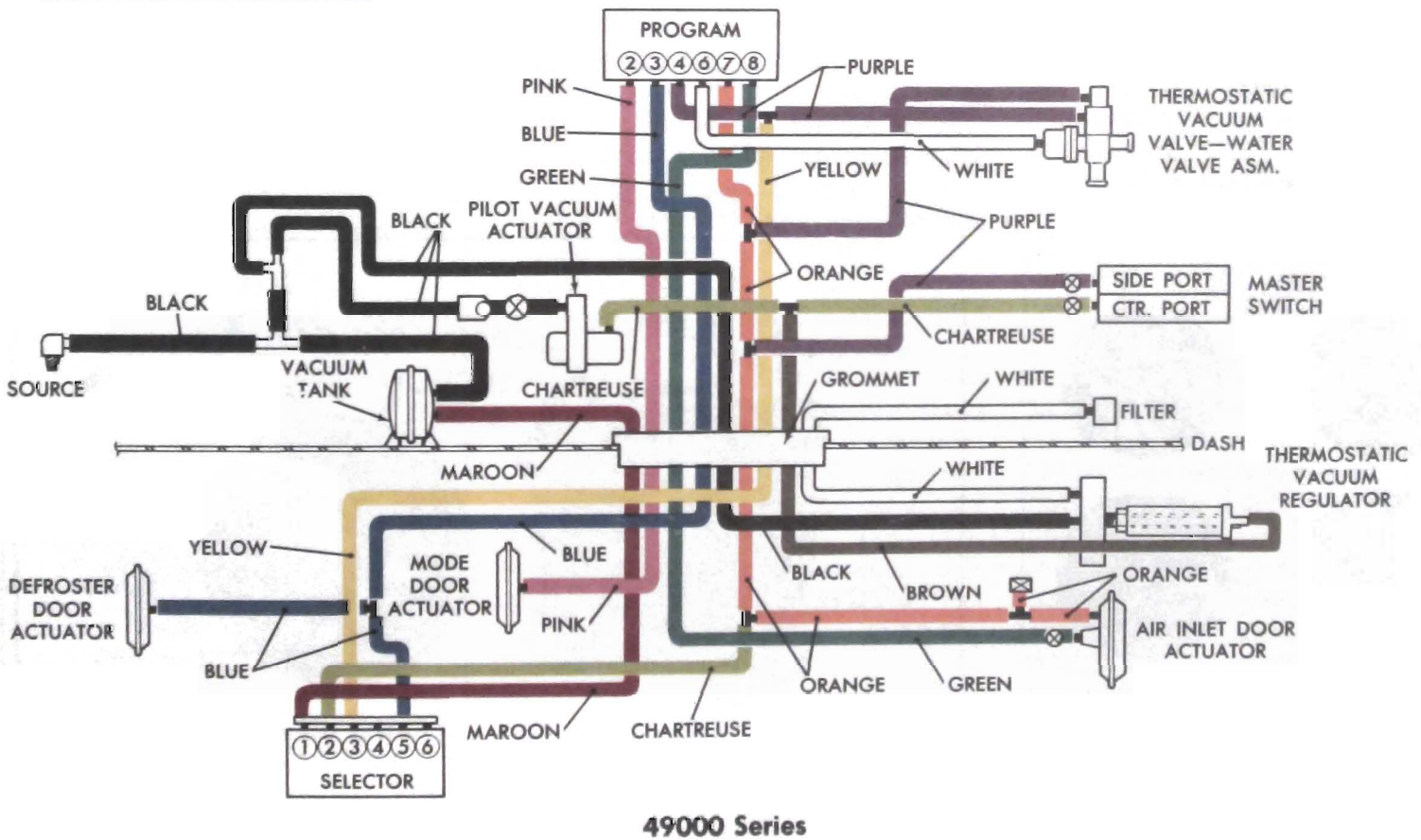
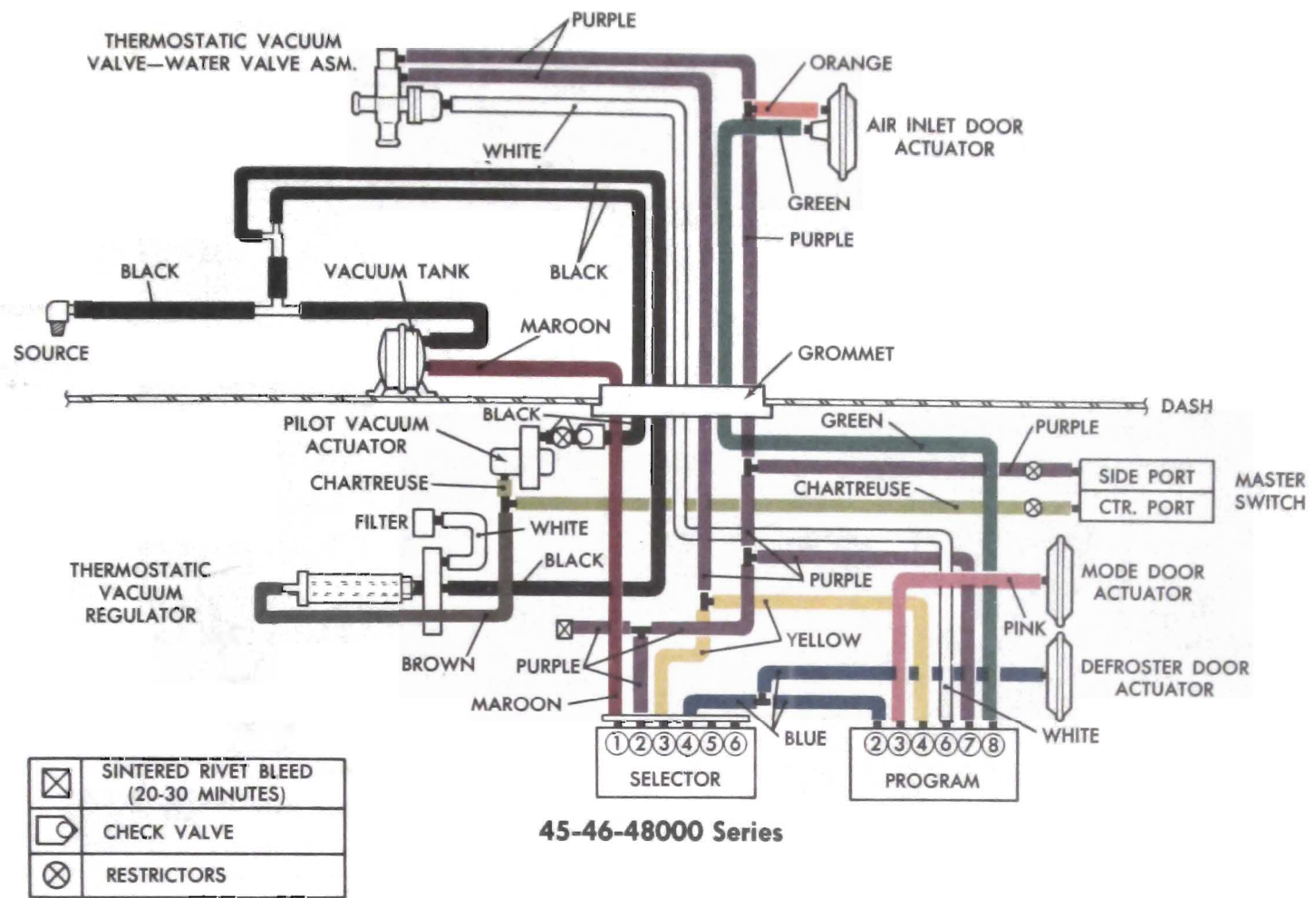

Figure 13-26 Air Conditioner Refrigeration Circuit

13-28 HEATER-AIR CONDITIONING SYSTEM

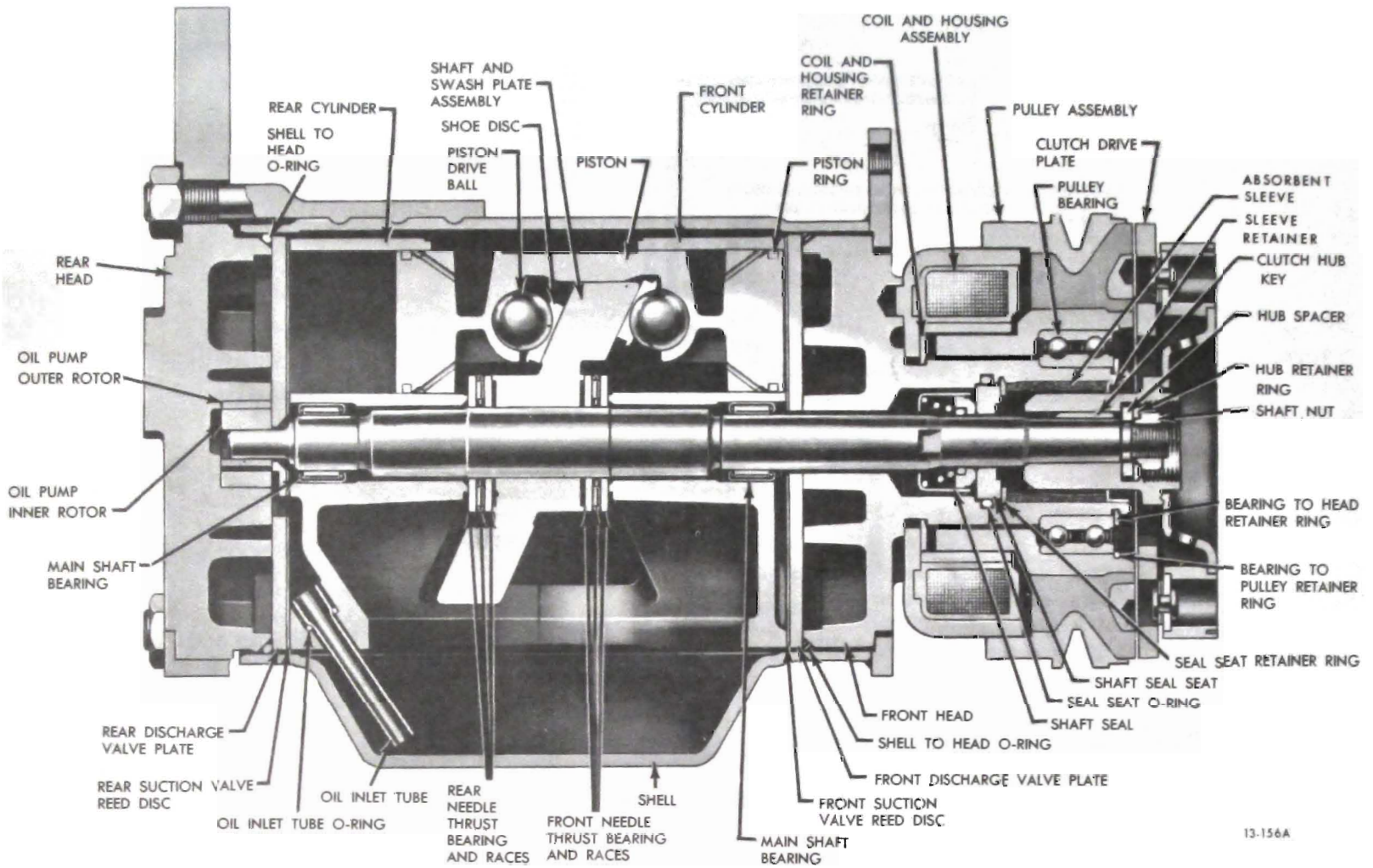

Figure 13-27 Compressor - Section View

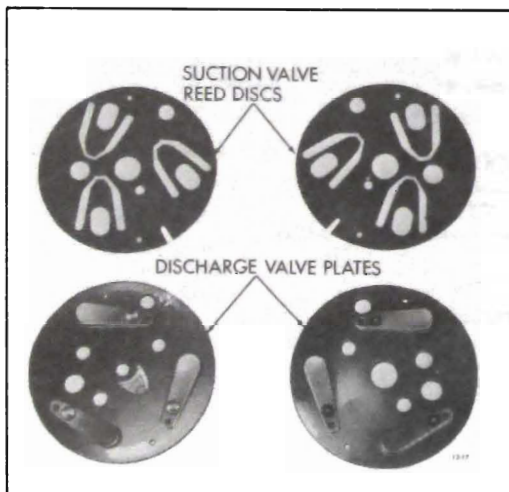

Figure 13-28 Compressor Suction Valve Reed Discs and Discharge Valve Plates

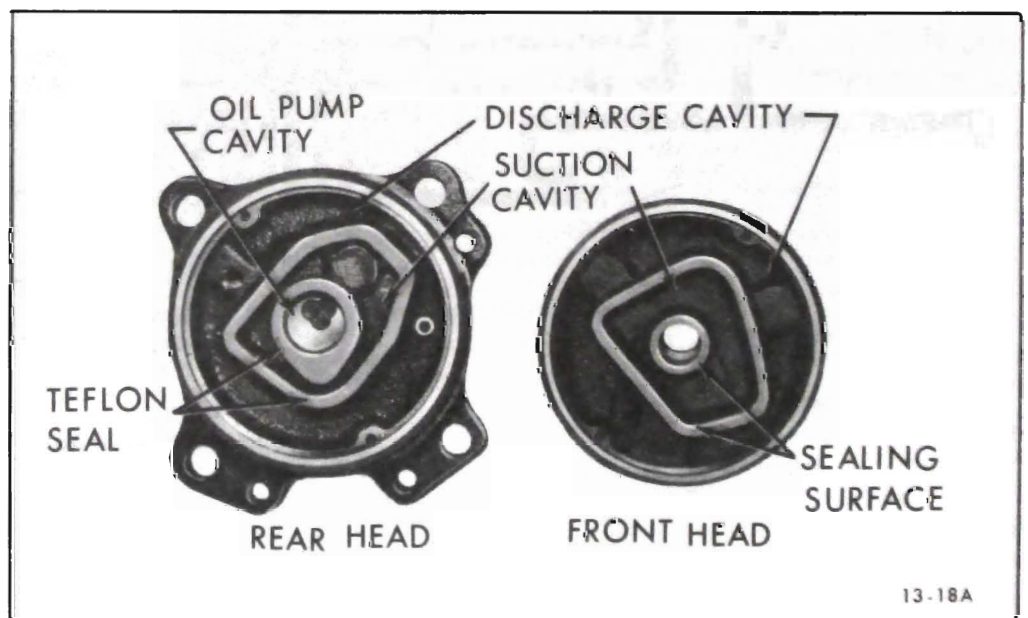

Figure 13-29 Compressor Front and Rear Heads

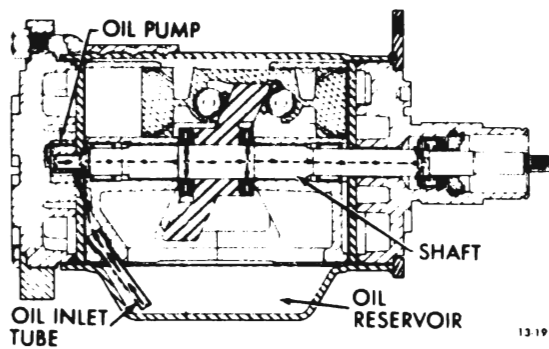

Figure 13-30 Compressor Oil Flow

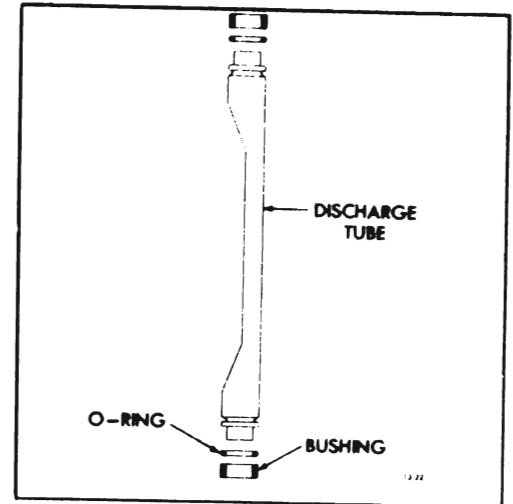

Figure 13-33 Service Replacement Discharge Tube

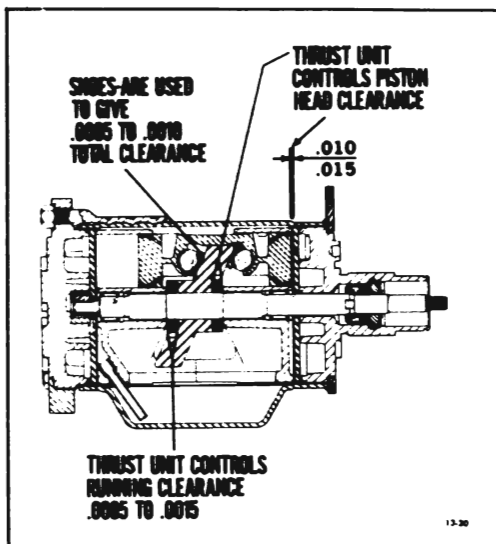

Figure 13-31 Compressor Needle Thrust Bearings and Races

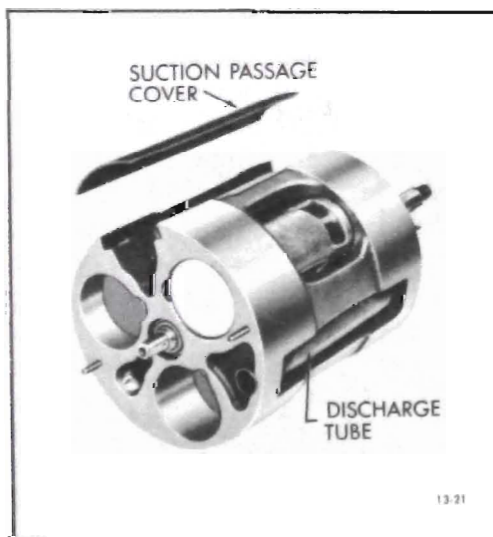

Figure 13-32 Suction Passage and Discharge Tube

temperature of 70°F. usually indicates an inadequate refrigerant charge. Bubbles or foam appearing at ambient temperatures below 70°F. do not necessarily indicate an inadequate charge and may appear even when the system is operating properly. A filter screen in the unit prevents foreign material from entering the remainder of the system.

e. Expansion Valve

The expansion valve is located at the rear of the engine compartment on the passenger side of the car. It is held secure by a bracket which is attached to the plenum blower assembly. The function of the expansion valve is to automatically regulate the flow of refrigerant into the evaporator. The expansion valve is the dividing point in the system between the high and low pressure liquid refrigerant. A temperature sensing bulb is connected by a capillary tube to the expansion valve (see Figure 13-36). The temperature sensing bulb (clamped to the outlet pipe on the evaporator) measures the temperature of the evaporator outlet pipe and transmits the temperature variations to the expansion valve (see Figure 13-26). The capillary tube and bulb are filled with carbon dioxide and sealed to one side of the expansion valve diaphragm.

An increase in temperature will cause the carbon dioxide in the bulb and capillary tube to expand, overcoming the spring pressure and pushing the diaphragm against the operating pins (see Figure 13-36).

This in turn will force the valve off its seat. When the refrigerant low pressure gas flowing through the outlet pipe of the evaporator becomes more than 6° higher or warmer than the temperature at which it originally began to vaporize or boil, the expansion valve will automatically allow more refrigerant to enter evaporator. If the temperature of the low pressure gas decreases to less than 6° above the temperature at which it originally began to vaporize or boil, the expansion valve will automatically reduce the flow of refrigerant. Thus, an increase or decrease in the flow of refrigerant through the evaporator will result in an increase or decrease in the cooling by the evaporator. The temperature, humidity and volume of the air passing over the evaporator affects the rate of absorption of heat by the evaporator. As the ambient temperature varies, the frequency which the temperature bulb calls for more or less refrigerant will increase or decrease. When the air is very warm, the heat transfer from the air to the refrigerant is great and a greater quantity of refrigerant is required to maintain the temperature at the evaporator pipe at the predetermined value. Conversely, cool days will result in less heat transfer and thereby require lesser quantities of refrigerant to maintain the predetermined temperature of the evaporator outlet pipe.

13-30 HEATER-AIR CONDITIONING SYSTEM

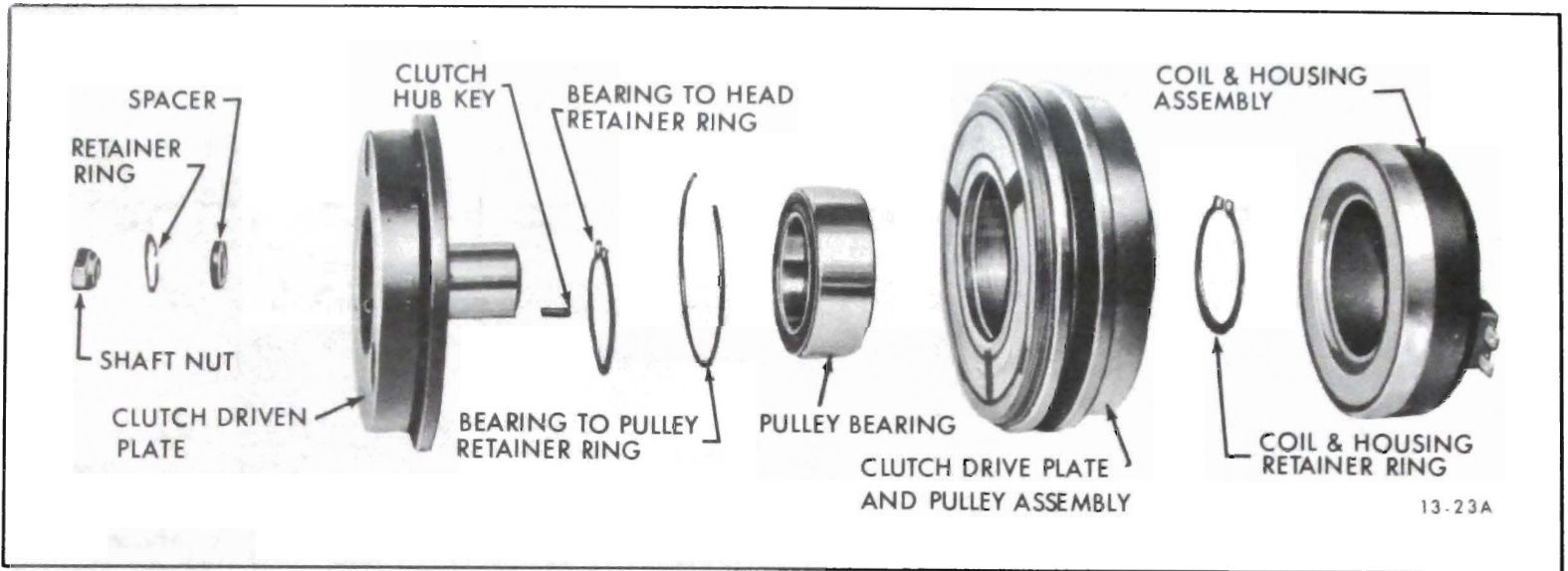

Figure 13-34 Magnetic Clutch and Pulley Assembly

An equalizer line connects the expansion valve to the suction throttling valve. The equalizer line is used primarily to prevent prolonged or constant operation of the compressor under conditions where it is not receiving enough refrigerant.

This operation is undesirable due to the resultant noise factor, and also due to the possibility of subjecting the compressor to reduced oil return. The equalizer line functions to permit the outlet pressure of the POA valve to be imposed on the diaphragm of the expansion valve. When the outlet pressure of the suction throttling valve drops below a predetermined pressure, this decrease in pressure is also transmitted to the diaphragm of the expansion valve, via the equalizer line. The expansion valve is caused to open

and flood refrigerant through the evaporator, thereby resulting in an increase in the evaporator pressure. This action only occurs during times when the compressor capacity becomes greater than the evaporator output with the resultant drop in POA suction throttling valve outlet pressure.

f. Evaporator

The function of the evaporator is to cool and dehumidify the air flow

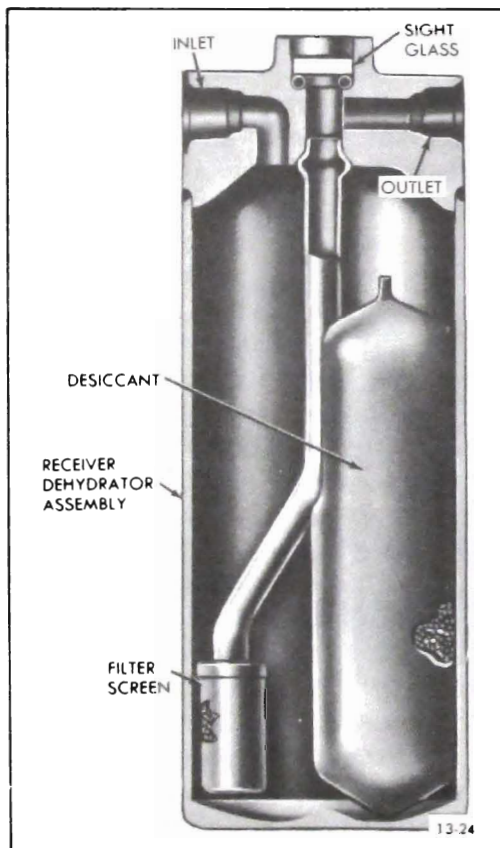

Figure 13-35 Receiver Dehydrator Assembly

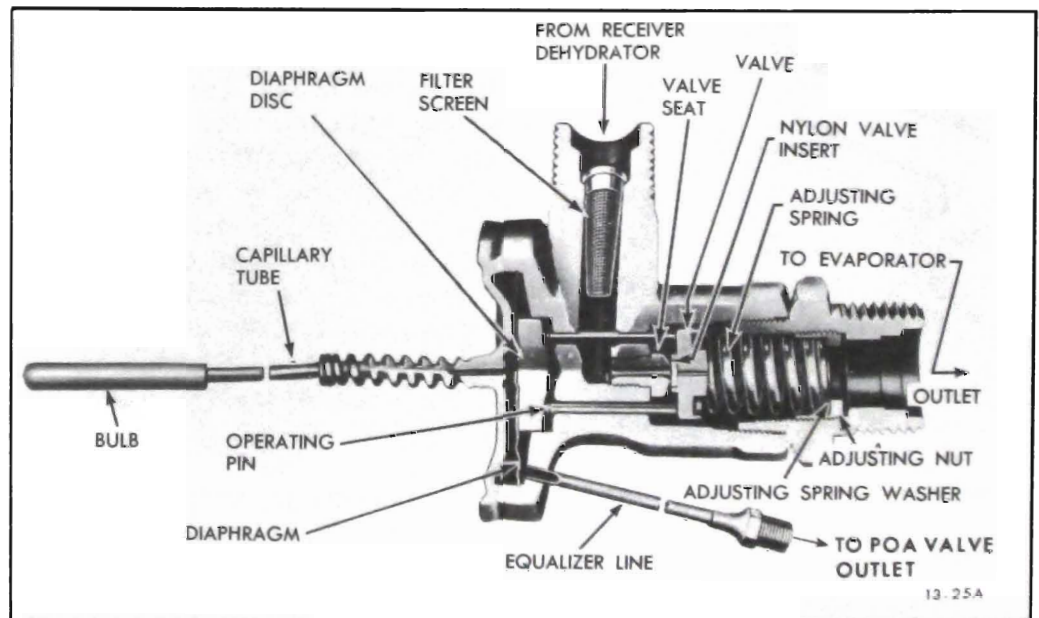

Figure 13-36 Expansion Valve

before it enters the passenger compartment. The evaporator assembly consists of an aluminum core enclosed in a reinforced plastic housing. A water drain port is located in the bottom of the housing. Two refrigerant lines are connected to the side of the evaporator core: one at the bottom and one at the top. The expansion valve is attached to the lower (inlet) pipe, and the suction throttling valve is attached to the upper (outlet) pipe. The temperature sensing bulb of the expansion valve is clamped to the outlet pipe of the evaporator core. The high pressure liquid refrigerant, after it is metered through the expansion valve, passes into the evaporator core where it is allowed to expand under reduced pressure. As a result of the reduced pressure the refrigerant begins to expand and return to the original gaseous state. To accomplish this transformation it begins to boil.

The boiling action of the refrigerant demands heat. To satisfy the demand for heat, the air passing over the core gives up heat to the evaporator and is subsequently cooled.

g. POA Valve

The pilot operated absolute suction throttling valve (POA valve) regulates the pressure inside the evaporator and thereby affects the air temperature at the instrument panel outlets (See Figure 13-37). The POA valve has a sealed inner chamber which controls the pressure regulating mechanism of the valve independently of the exterior atmospheric pressure. This design insures that the valve does not change its calibration as the system is operated in various altitudes. It should be remembered; however, that any gage used to check the valve pressure will not be free from the effect of atmospheric pressure. For this reason it might appear that it is the pressure within the valve that is changing. Actually the reverse is true. The pressure within the valve remains unaffected by atmospheric variations, while the gage used to read

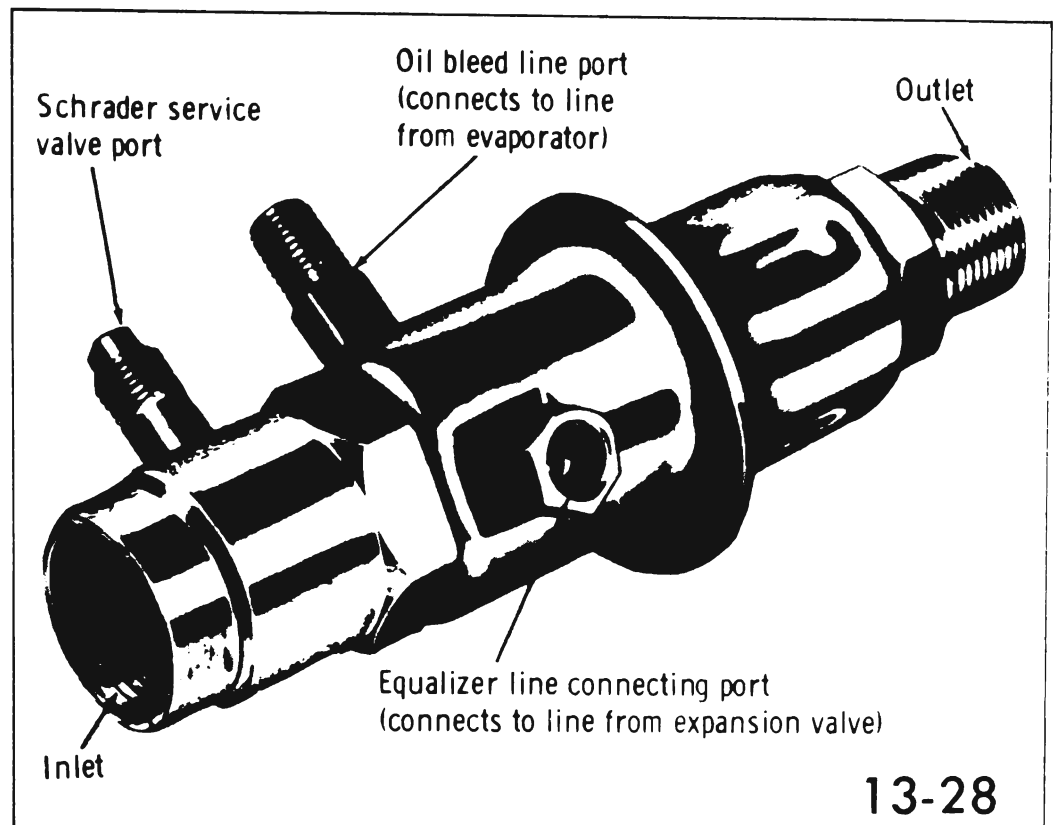

Figure 13-37 Pilot Operated Absolute - Suction Throttling Valve (POA Valve)

these pressures is affected by atmospheric pressure. The table shown in Figure 13-38 indicates the gage pressure that should be obtained at various altitudes. If readings are obtained other than these, it is likely that the valve is malfunctioning. The POA valve cannot be disassembled or adjusted. If it is determined that the valve is malfunctioning, it should be replaced.

h. Fan Drive Clutch Assembly

During periods of operation when radiator discharge air temperature is low (below approximately 150°F.), the fan clutch limits the fan speed to 800- 1600 RPM. Under these conditions the clutch is disengaged since a small oil pump gear driven by the separator plate forces the silicone oil into the reservoir between the separator plate and the front cover assembly. Under these conditions also, the passage from this cavity to the clutch area is closed by the coil spring leaf valve. As operating conditions produce a high radiator discharge air temperature (above

approximately 150 degrees F.), the temperature sensitive bimetal coil tightens to move the leak valve (attached to the coil) which opens a port in the separator plate. Silicone oil flows into the clutch chamber engaging the clutch and providing a maximum fan speed of approximately 2350 RPM.

The clutch coil is calibrated so that at road load with an ambient temperature of approximately 90°F., the clutch is just at a point of shift between high and low fan speed.

No attempt should be made to disturb the calibration of the engine fan clutch assembly as each assembly is individually calibrated at the time of manufacture.

DIVISION III

SERVICE PROCEDURES

(SERVICING REFRIGERANT CHARGED COMPONENTS)

13-32 HEATER-AIR CONDITIONING SYSTEM

ALTITUDE OF LOCALE (FT.)	GAGE PRESSURE (PSI)	ALTITUDE OF LOCALE	GAGE PRESSURE (PSI)
0 (Sea Level)	28.5	6000	31.4
1000	29.0	7000	31.8
2000	29.5	8000	32.3
3000	30.0	9000	32.7
4000	30.5	10000	33.2
5000	31.0		

Allowable tolerance of POA valve is \pm 1 psi 13-29A

Figure 13-38 Table of Altitude Corrected Gage Pressure for Evaluating POA Valve Performance

13-14 GENERAL SERVICE INFORMATION AND SAFETY PRECAUTIONS

a. General Information

All subassemblies are shipped sealed and dehydrated. They are to remain sealed until just prior to making connections, and should be at room temperature before uncapping. This prevents condensation of moisture from air that enters the system.

All precautions should be taken to prevent damage to fittings or connections. Even minute damage to a connection could cause it to leak. Any fittings with grease or dirt on them should be wiped clean with a cloth dipped in alcohol.

Do not clean fitting or hoses with solvents because they are contaminants. If dirt, grease or moisture gets inside the pipes or hoses and cannot be removed, the pipe or hose is to be replaced. Use a small amount of clean refrigeration oil on all tube and hose connecting joints, and lubricate the "O" ring gasket with this oil before assembling the joint. The oil will help in effecting a leak-proof joint and assist the "O" ring to slip into the proper location without being cut or damaged. Always use new "O" rings.

When tightening joints, use a second wrench to hold the stationary part of the connection to prevent twisting and to prevent hose kinking. Kinked hoses are apt to transmit noise and vibration. Tighten all connections in accordance with recommended torques (see Figure 13-1).

Do not connect receiver-dehydrator assembly until all other connections have been made. This is necessary to insure maximum moisture removal from system.

It is important that air conditioning hoses do not rest on or contact body or chassis sheet metal except where necessary. Because of the high frequency at which the compressor operates, the passenger compartment is susceptible to transfer of noise.

b. Safety Precautions

The following safety precautions should always be followed when servicing refrigerant charged components:

1. Do not leave Refrigerant-12 cylinder uncapped.
2. Do not carry cylinder in passenger compartment of car.
3. Do not subject cylinder to high temperatures.

4. Do not weld or steam clean on or near cylinder.

5. Do not fill cylinder completely.

6. Do not discharge vapor into area where flame is exposed or directly into engine air intake.

7. Do not expose eyes to liquid - **WEAR SAFETY GOGGLES** whenever discharging, charging or leak testing system.

13-15 DISCHARGING SYSTEM

Removal of any part in the refrigerant circuit will require discharging of the entire system.

1. Remove protective cap from the Schrader valve located on the POA valve and Schrader valve located on discharge port of compressor.

2. Install Adapters (J-5420) onto each Schrader valve, see Figure 13-49, and connect a Gage Charging Line (J-5418) between each adapter and the outer connecting ports of the Manifold and Gage Set (J-5725-01). Both valves of manifold and gage set must be closed.

3. Hold a large size rag over center port of manifold and gage set and slowly open both valves on manifold and gage set until refrigerant starts to flow without discharging refrigerant oil.

NOTE: Do not open valves too fast as oil will be blown out of system.

13-16 ADDING OIL TO THE SYSTEM

The oil in the refrigeration system does not remain in the compressor during system operation, but circulates throughout the system. The compressor is initially charged with 10-1/2 oz. of 525 viscosity oil. After system has been in operation the oil content in the compressor will vary depending on the engine RPM and air conditioning load. At higher engine RPM's a lesser amount of oil

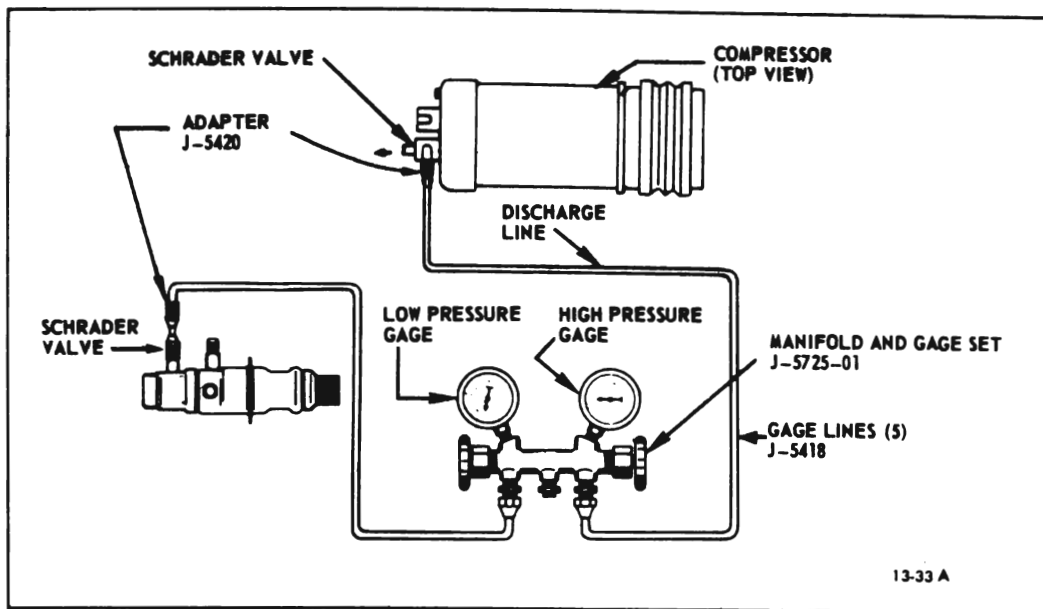

Figure 13-49 Set-Up for Discharging System

The refrigeration system will not require adding of oil unless there is an oil loss because of a ruptured line, badly leaking compressor seal, replacement of evaporator, compressor, receiver-dehydrator, or loss due to a collision. Oil is generally added to the system via the oil drain hole in the lower side of the compressor. To add oil to the system via the compressor, the compressor must be removed. If no major loss of oil has occurred and a component (condenser, receiver-dehydrator or evaporator) is removed for servicing, the oil may be added directly to the component. To add oil to a component removed for servicing and when no major loss has occurred, drain and measure oil in component, then replace with a like amount. To add oil to the system when a major loss of oil is evidenced, or when the compressor is being serviced, remove compressor, drain and measure oil,

will be retained in the compressor reservoir. It is important that the total system oil content does not vary from a total of 10-1/2 oz. Excessive

oil content will reduce cooling capacity. Inadequate oil content may result in damage to compressor moving parts.

CONDITION	AMOUNT OF OIL DRAINED FROM COMPRESSOR	AMOUNT OF 525 OIL TO INSTALL IN COMPRESSOR
1. Major loss of oil and a component (condenser, receiver-dehydrator, or evaporator) has to be replaced.	a. More than 4 oz.	a. Amount drained from compressor plus amount for component being replaced: Evaporator—Add 2 oz. Condenser—Add 1 oz. Receiver Dehydrator—Add 1 oz.
	b. Less than 4 oz.	b. Install 6 oz. plus amount for component being replaced as shown above.
2. Compressor being replaced with a service replacement compressor—no major oil loss.	a. More than 1-1/2 oz.	a. Same amount as drained from compressor being replaced.
	b. Less than 1-1/2 oz.	b. Install 6 oz.
3. Compressor being replaced with a service replacement compressor—major oil loss evident.	a. More than 4 oz.	a. Same amount as drained from compressor being replaced.
	b. Less than 4 oz.	b. Install 6 oz.
4. Compressor being rebuilt or repaired—no major oil loss evident.	a. More than 1-1/2 oz.	a. Same amount as drained from compressor plus 1 oz. additional.
	b. Less than 1-1/2 oz.	b. Install 7 oz.
5. Compressor being rebuilt or repaired—major loss of oil evident.	a. More than 4 oz.	a. Same amount as drained from compressor plus 1 oz. additional.
	b. Less than 4 oz.	b. Install 7 oz.

13-34A

Figure 13-50 Oil Replacement Table

13-34 HEATER-AIR CONDITIONING SYSTEM

and replace oil amount specified in Figure 13- 51.

If foreign material is noted in oil drained from system or evidence of moisture is obvious in the components removed, it is recommended that the entire system be flushed (ref. par. 13-17) and the receiver-dehydrator be replaced. A full oil charge of 10-1/2 oz. of 525 viscosity refrigeration oil should be replaced in the system. It should be noted that all service replacement compressors will be supplied with 10-1/2 oz. of oil. In most cases it will be necessary to drain oil from service replacement compressor and refill it with amount as specified in Figure 13-50.

13-17 FLUSHING THE SYSTEM

Flushing of the system may involve all the components of the system or individual components in the system. The components may be flushed while mounted in the engine compartment or may be removed for flushing. When a component is not removed, disconnect all refrigerant lines or hoses attached to component. To perform flushing operation, connect a cylinder of refrigerant-12 to the component to be flushed, then invert the cylinder and open the cylinder valve so that the liquid refrigerant pours out and through the component.

CAUTION: *When liquid Refrigerant-12 reaches atmospheric pressure it immediately drops to -21.7°F. Insure that area immediately surrounding outlet of component is clear of anything that may be damaged by contact because of the sudden drop in temperature.*

In all cases where a complete system flushing operation is performed, the receiver-dehydrator and the filter screen on the expansion valve should be replaced. If the evaporator assembly is flushed while installed in the car, the temperature bulb on the evaporator outlet pipe must be disconnected to keep the expansion valve from closing at the inlet source.

NOTE: *It is recommended that dry nitrogen be used as a flushing agent due to the low cost involved. In addition, dry nitrogen will not cause a temperature drop, as in the case of refrigerant-12, which results in thickening of refrigerant oil. Dry nitrogen has the additional advantage of removing moisture from the system.*

13-18 REMOVAL AND INSTALLATION OF COMPRESSOR**a. Removal**

1. Discharge refrigerant from system (refer to par. 13-15).
2. Remove wire connector from compressor.
3. Remove bolt and plate holding suction and discharge lines into rear head. Disengage both lines from compressor and tape closed openings in both lines and ports in rear head.

NOTE: *It is important to seal compressor ports to avoid a loss of refrigeration oil and also to prevent foreign material and moisture from entering compressor.*

4. Remove bolts in slots of compressor mounting brace (see Figure 13-51, 13-52, or 13-53) and tilt compressor inward.
5. Remove two bolts holding front and rear adapter plates to compressor mounting bracket and lift out compressor.

NOTE: *During removal, maintain the compressor positioned so that the sump is downward. Do not rotate compressor shaft.*

b. Installation

1. Installation is reverse of removal. Torque bolts as specified in Figure 13-51, 13-52, or 13-53.

NOTE: *Insure that compressor has sufficient oil charge.*

2. Use new "O" rings when attaching suction and discharge lines.
3. Adjust compressor belt tension to 100 pounds using Belt Tension Gage (J-7316).
4. Charge compressor (refer to par. 13-29).
5. Make sure compressor hoses are properly aligned and do not have any direct contact with sheet metal or each other.

13-20 DISASSEMBLY AND REASSEMBLY OF CLUTCH DRIVE PLATE AND SHAFT SEAL

NOTE: *It is not necessary to remove the compressor or disconnect refrigerant lines to remove or install clutch parts. However, it is necessary to position the compressor out of the mounting brackets for tool clearance.*

a. Disassembly

1. Firmly clamp holding fixture (J-9396) in a vise and attach compressor assembly to fixture (see Figure 13-61).
2. Hold hub of clutch drive plate with wrench (J-9403). Using special thin wall 9/16 inch socket (J-9399) and 3/8 inch drive, remove shaft nut.
3. Install threaded hub puller (J-9401) onto hub of clutch drive plate (see Figure 13-62). Hold body of hub puller with wrench, tighten center screw of hub puller, and lift off clutch drive plate and woodruff key.
4. Using No. 21 Truarc pliers (J-5403) take out retainer ring from hub of clutch drive plate (see Figure 13-63). Lift out spacer.
5. If compressor has an absorbent sleeve in the neck, pry out the sleeve retainer and remove the sleeve. Remove the seal seat retainer ring, using No. 21 Truarc pliers, Tool J-5403, (see Figure 13- 64).

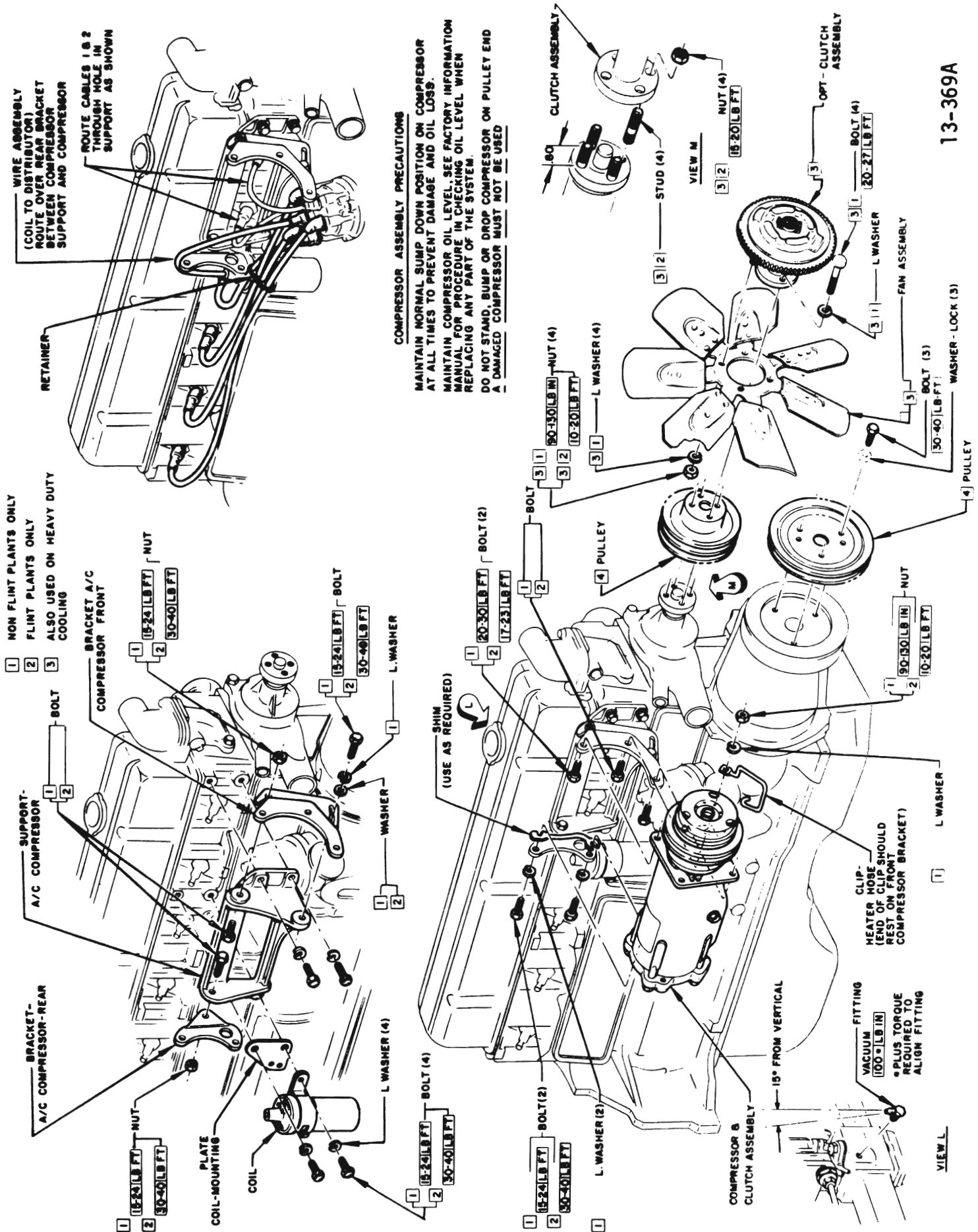

Figure 13-51 Compressor Installation, L-6 Engine

13-36 HEATER-AIR CONDITIONING SYSTEM

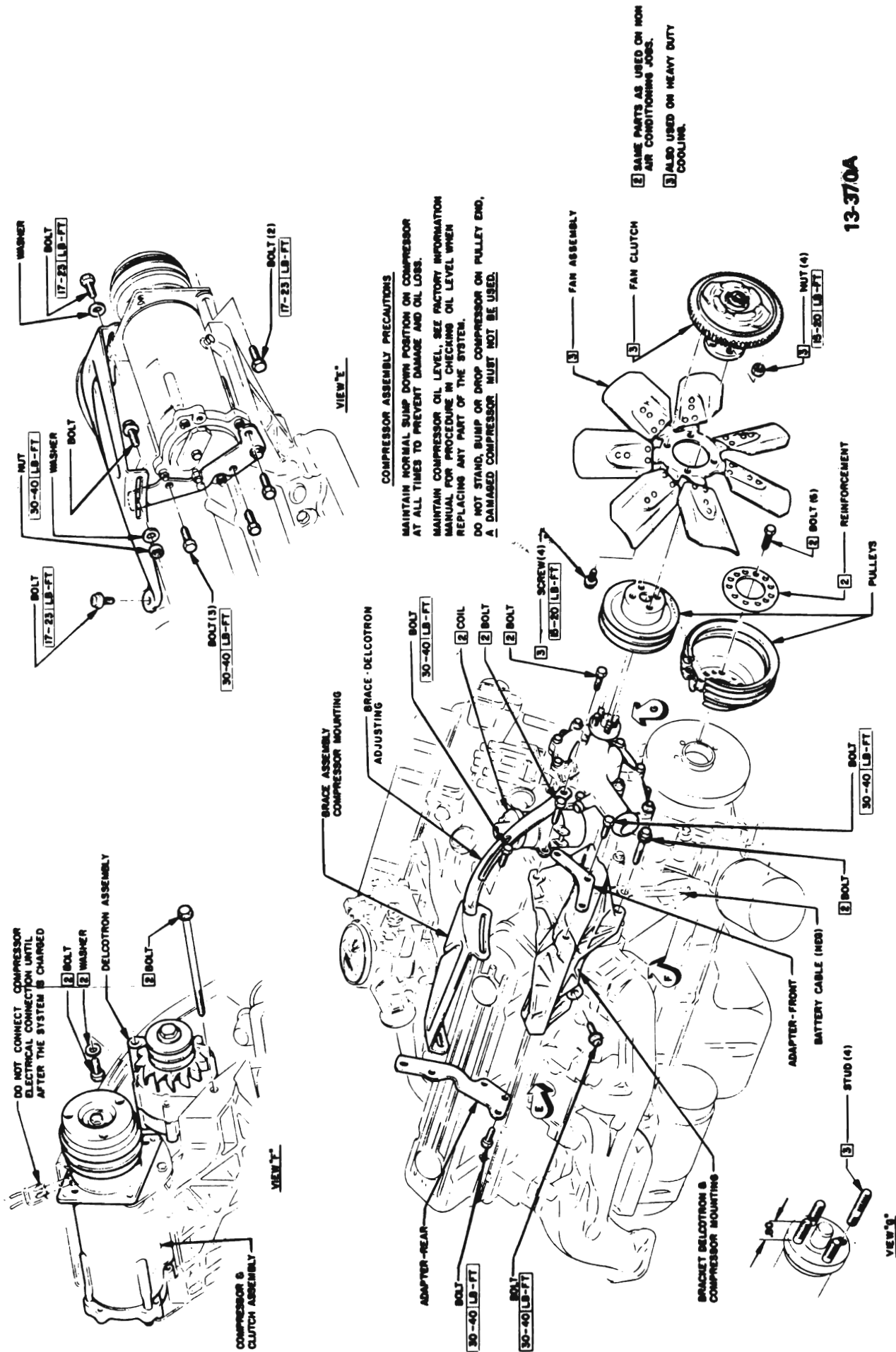
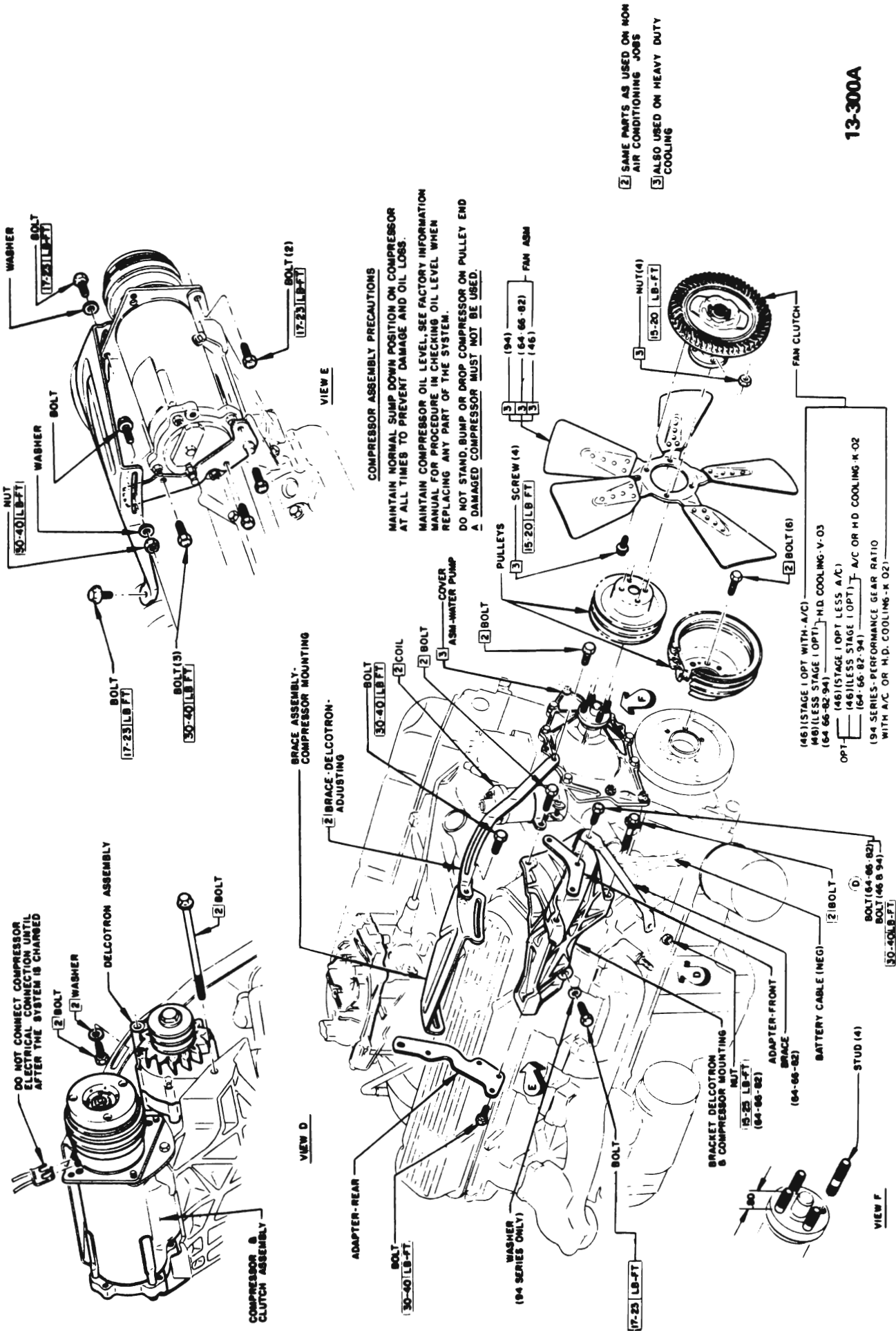
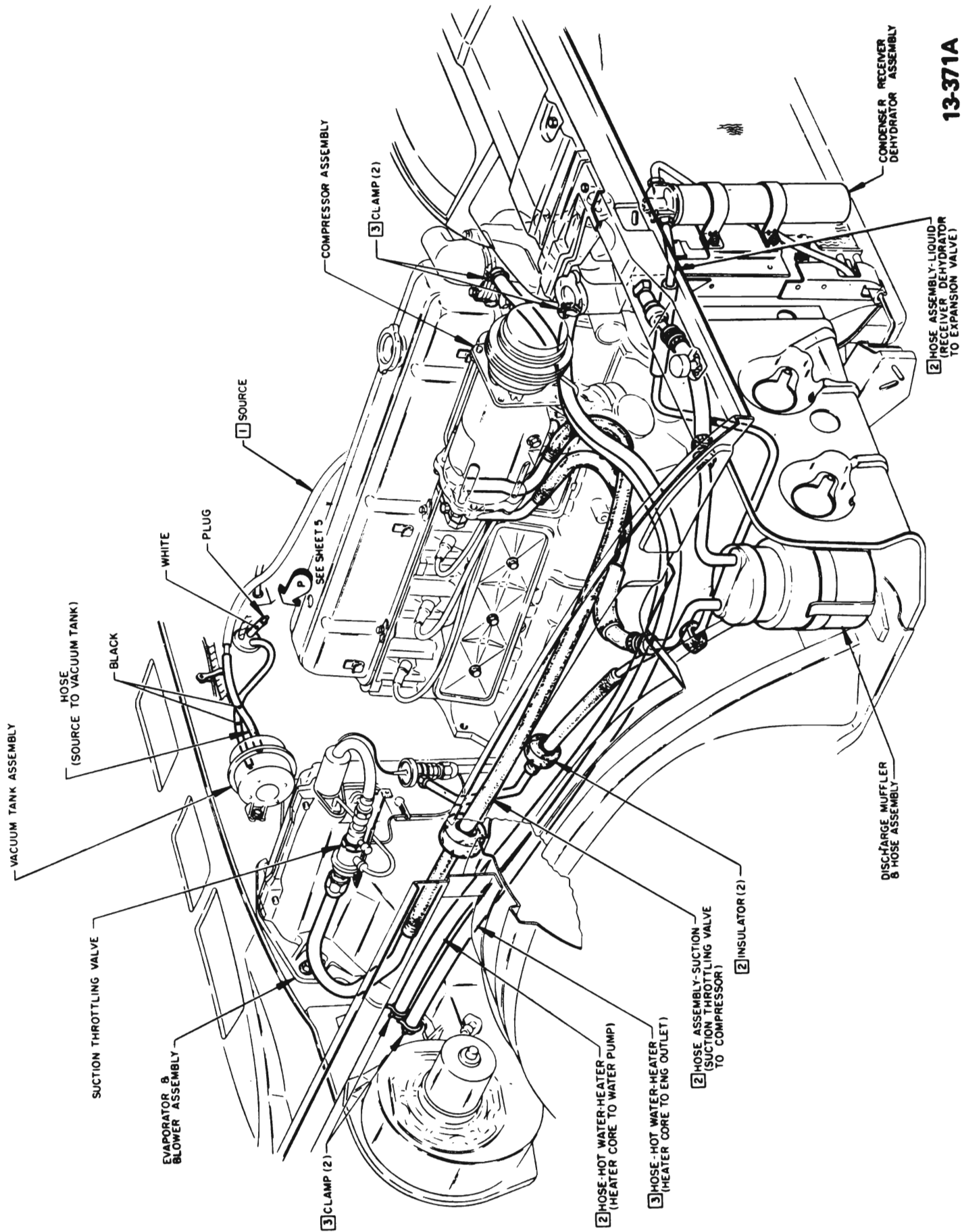

Figure 13-52 Compressor Installation, 350 Cu. In. V-8 Engine



13-38 HEATER-AIR CONDITIONING SYSTEM



13-371A

Figure 13-54 Refrigerant Line Installation, 43-44000 Series L-6 Engine

SUCTION THROTTLING VALVE

- 1- THE OPERATION OF THE SUCTION THROTTLING VALVE MUST BE CHECKED DURING FUNCTIONAL TEST.
- 2- THE SUCTION THROTTLING VALVE WILL BE ADJUSTED AT THE SOURCE. IN THE EVENT SUCTION PRESSURES DO NOT FALL WITHIN THE REQUIRED LIMITS, REPLACE THE VALVE.

GENERAL INSTRUCTIONS

REMOVE ALL PROTECTIVE COVERS FROM REFRIGERANT LINES JUST BEFORE INSTALLATION.

ASSEMBLY & HANDLING PRECAUTIONS SHOWN ON A/C PROCEEDURE CHART FOR LINE CONNECTIONS ARE MANDATORY & MUST BE FOLLOWED.

REFRIGERANT LINES ARE TO BE ASSEMBLED WITH NO DIRECT CONTACT AND TO HAVE METAL CONTACT WITH SHEET METAL OR WITH EACH OTHER, POSITION INSULATORS ACCORDINGLY.

EACH COMPLETED AIR CONDITIONING SYSTEM MUST BE LEAK TESTED & GIVEN A FUNCTIONAL TEST AFTER CHANGING.

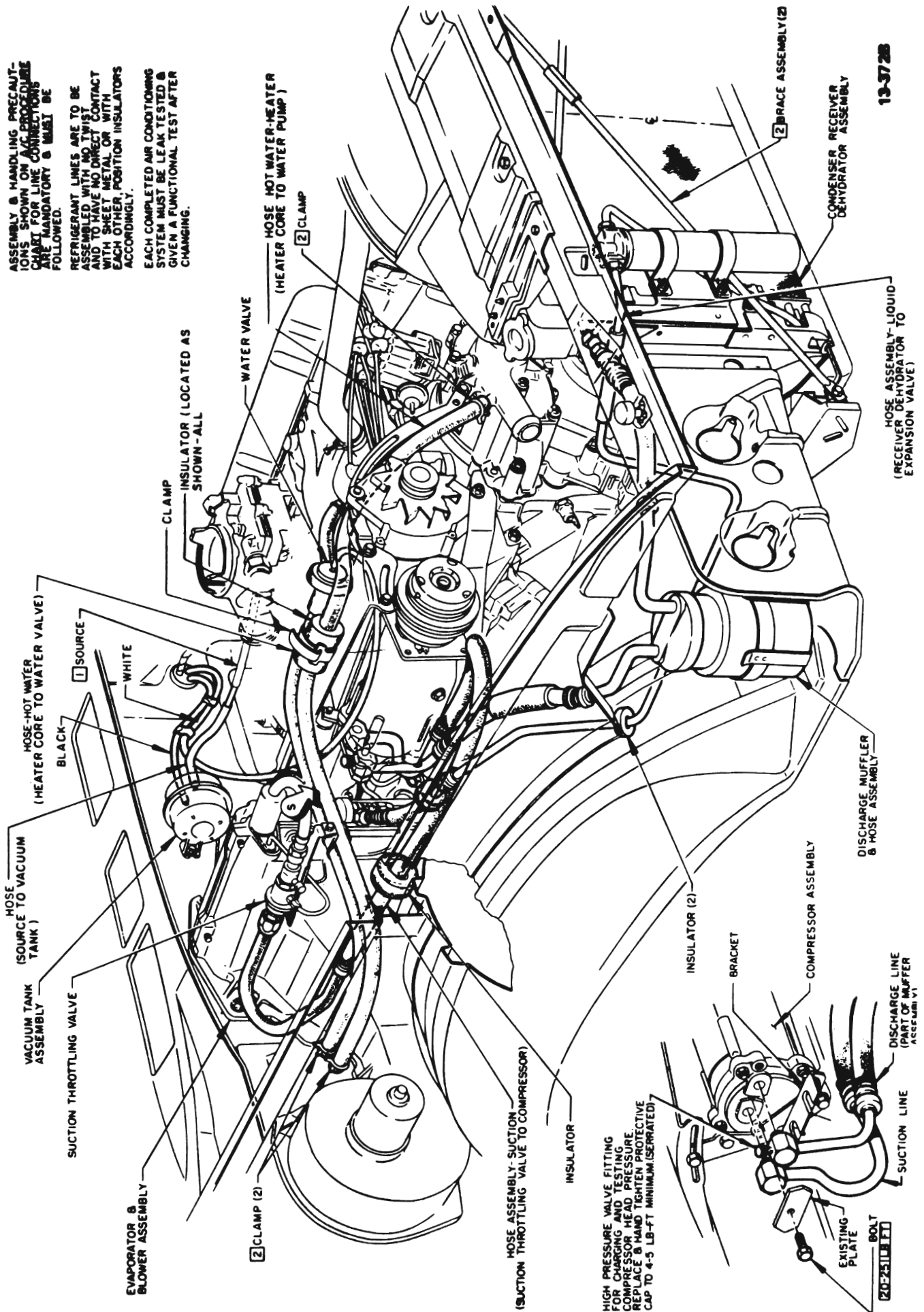

13-3728

Figure 13-55 Refrigerant Line Installation, 43-44000 Series V-8 Engine

13-40 HEATER-AIR CONDITIONING SYSTEM

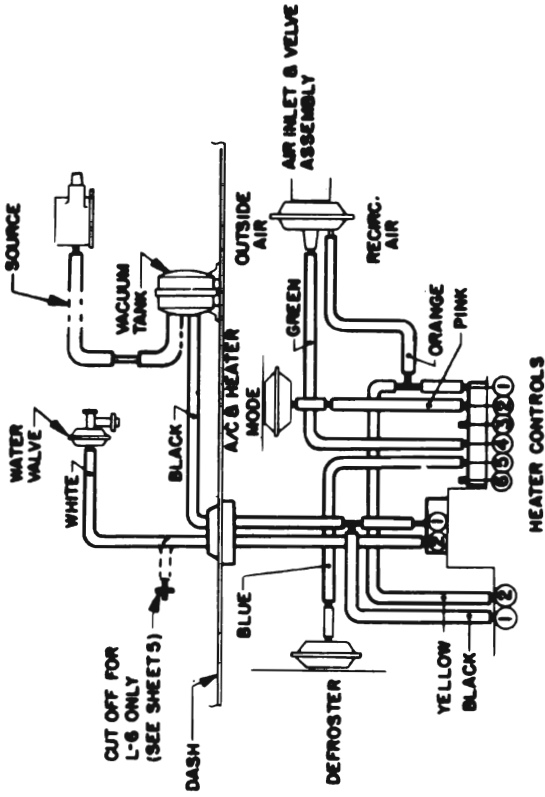

VACUUM HOSE CHART

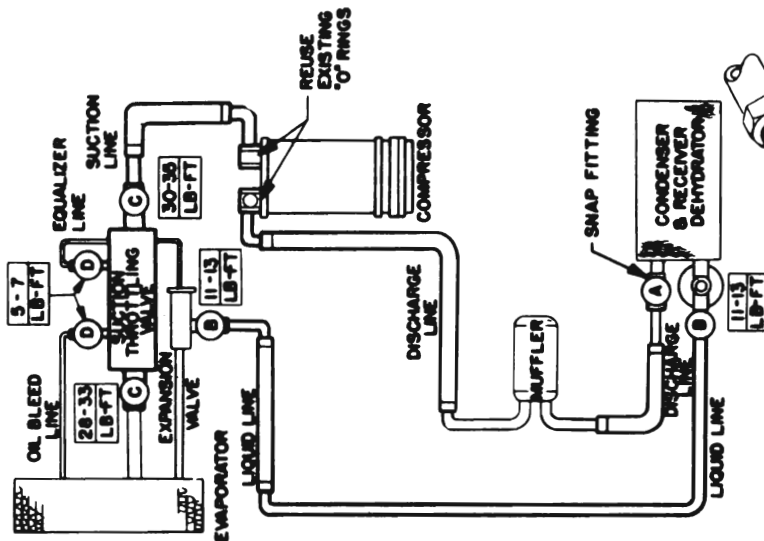

USE OIL ON ALL JOINTS & "O" RING GASKETS FOR EASE OF ASSEMBLY

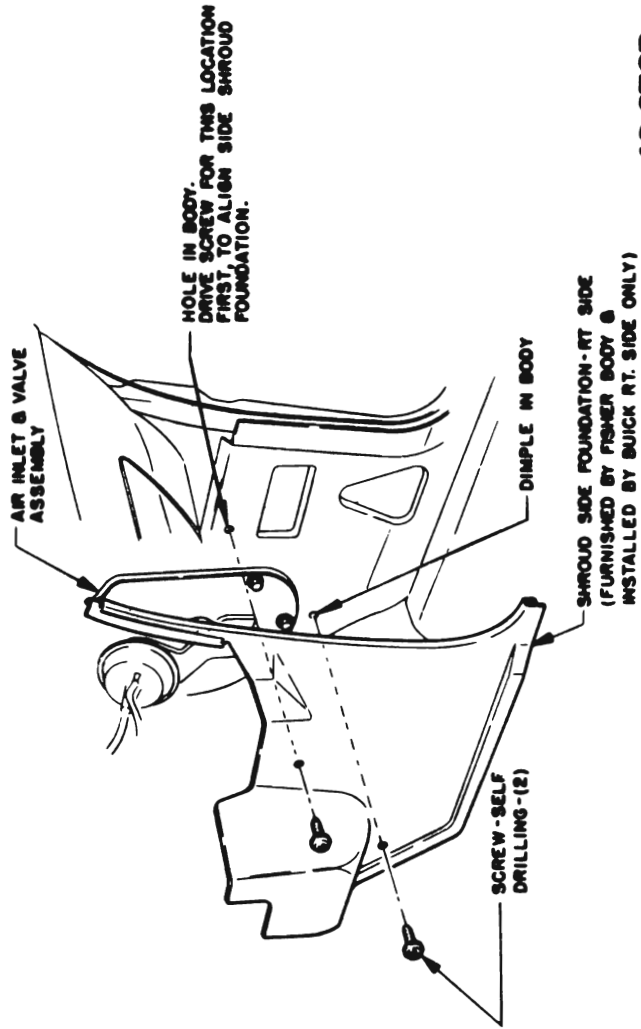
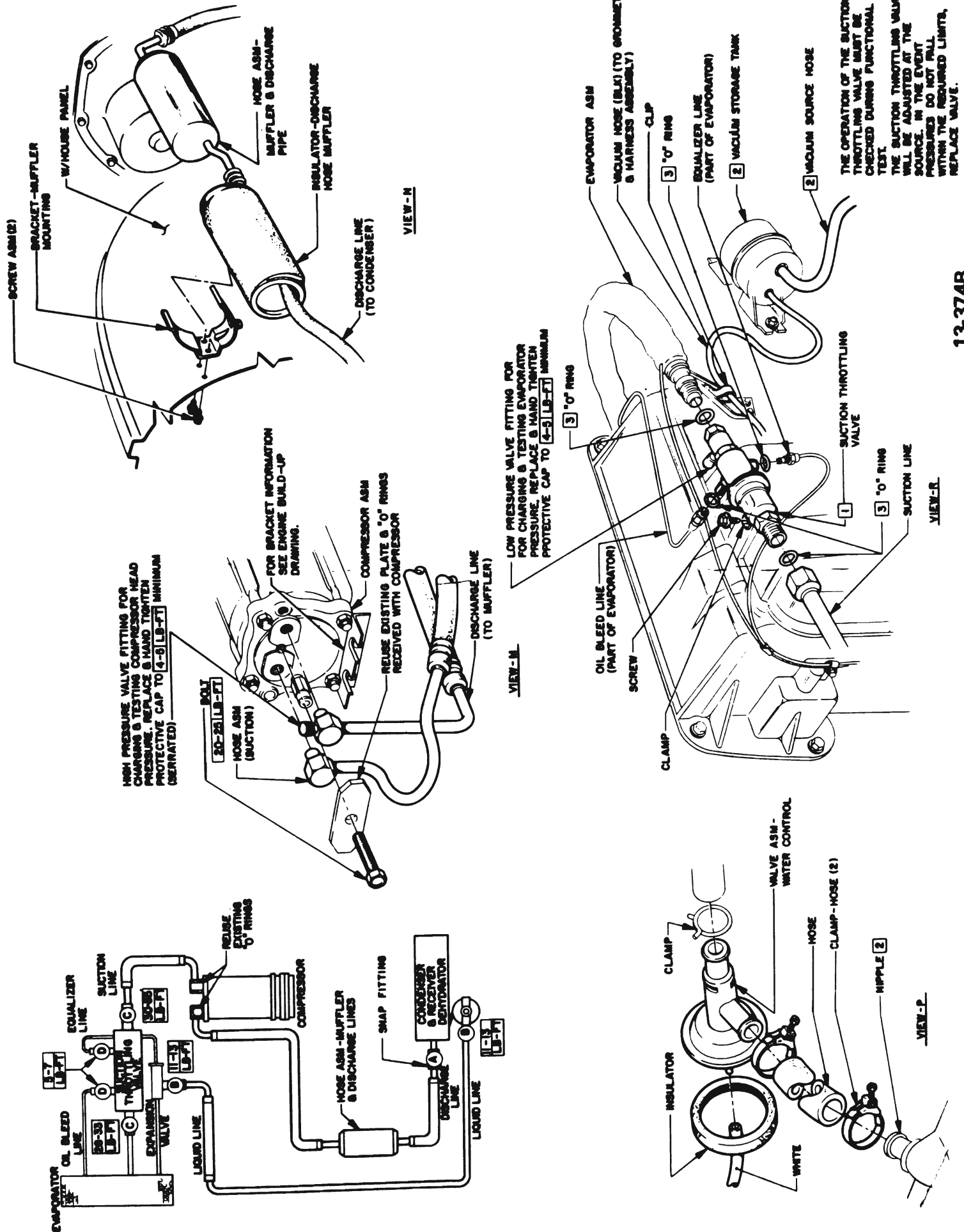

Figure 13-56 Refrigerant Line Torque Requirements and Vacuum Hose Chart, 43-44000 Series

13-3738



THE OPERATION OF THE SUCTION THROTTLING VALVE MUST BE CHECKED DURING FUNCTIONAL TEST.
THE SUCTION THROTTLING VALVE WILL BE ADJUSTED AT THE SOURCE. IN THE EVENT PRESSURES DO NOT FALL WITHIN THE REQUIRED LIMITS, REPLACE VALVE.

13-374B

Figure 13-57 Refrigerant Line Installation, 45-46-48000 Series

13-42 HEATER-AIR CONDITIONING SYSTEM

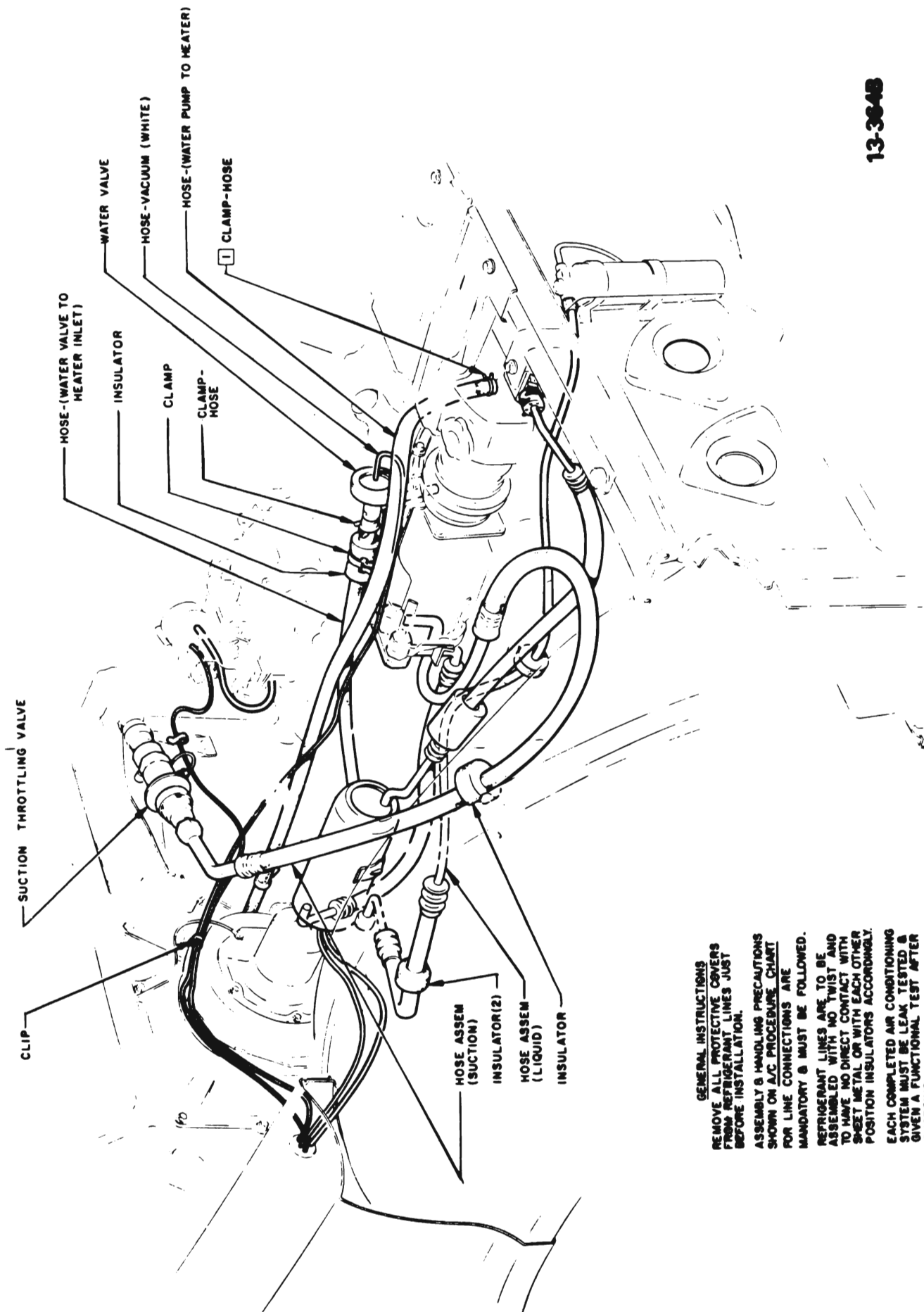

13-364B

GENERAL INSTRUCTIONS
 REMOVE ALL PROTECTIVE COVERS FROM REFRIGERANT LINES JUST BEFORE INSTALLATION.
 ASSEMBLY & HANDLING PRECAUTIONS SHOWN ON A/C PROCEDURE CHART FOR LINE CONNECTIONS ARE MANDATORY & MUST BE FOLLOWED.
 REFRIGERANT LINES ARE TO BE ASSEMBLED WITH NO TWIST AND TO HAVE NO DIRECT CONTACT WITH SHEET METAL OR WITH EACH OTHER POSITION INSULATORS ACCORDINGLY.
 EACH COMPLETED AIR CONDITIONING SYSTEM MUST BE LEAK TESTED & GIVEN A FUNCTIONAL TEST AFTER CHARGING.

Figure 13-58 Refrigerant Line Installation, and Vacuum Hose Chart 45-46-48000 Series

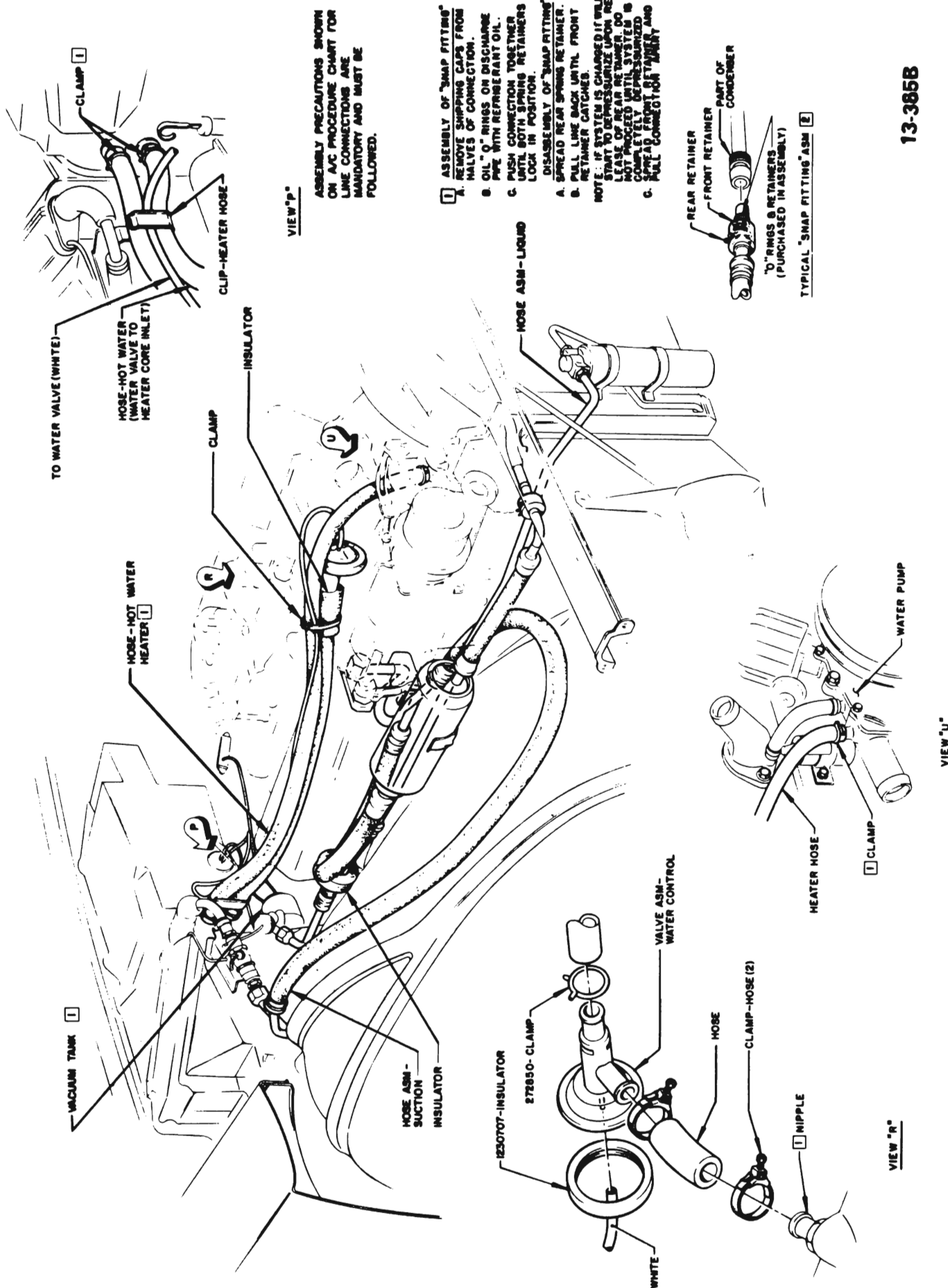

13-385B

Figure 13-59 Refrigerant Line Installation, 49000 Series

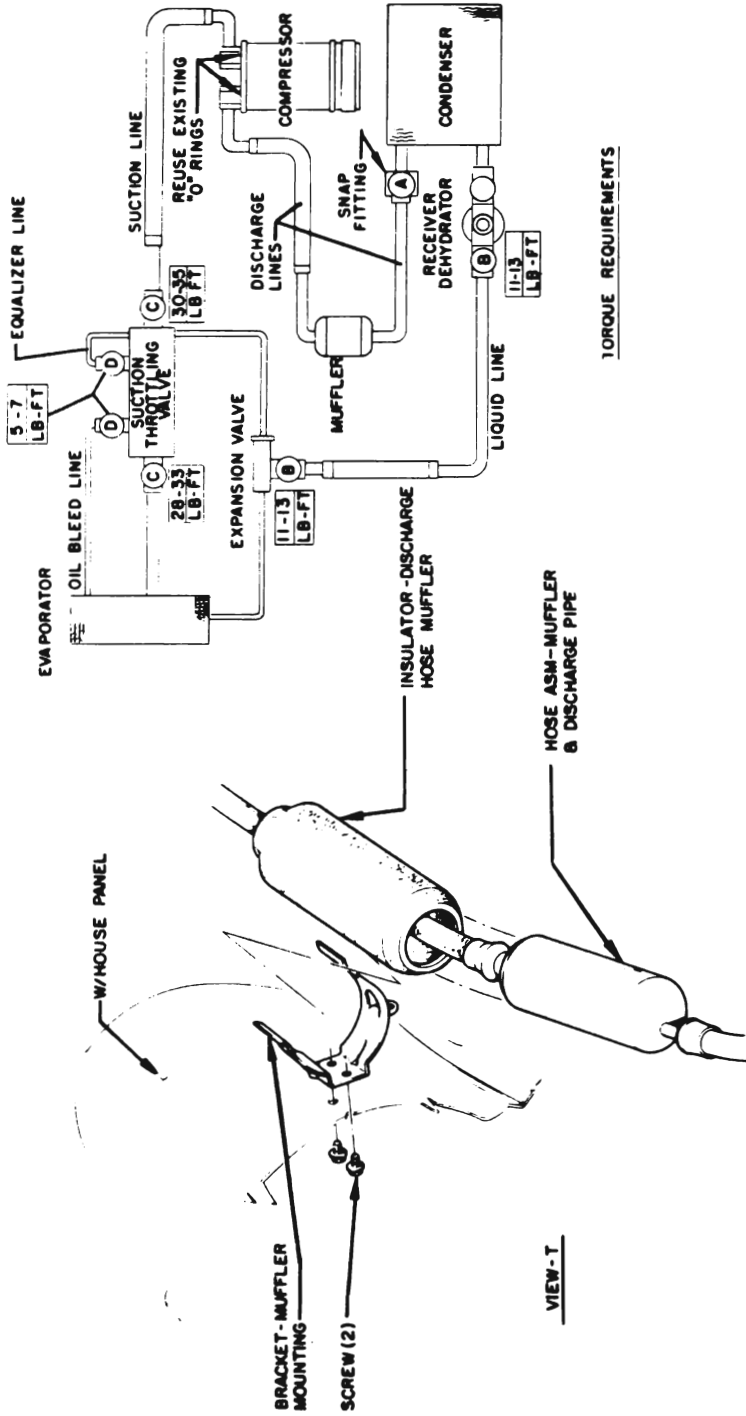

TORQUE REQUIREMENTS

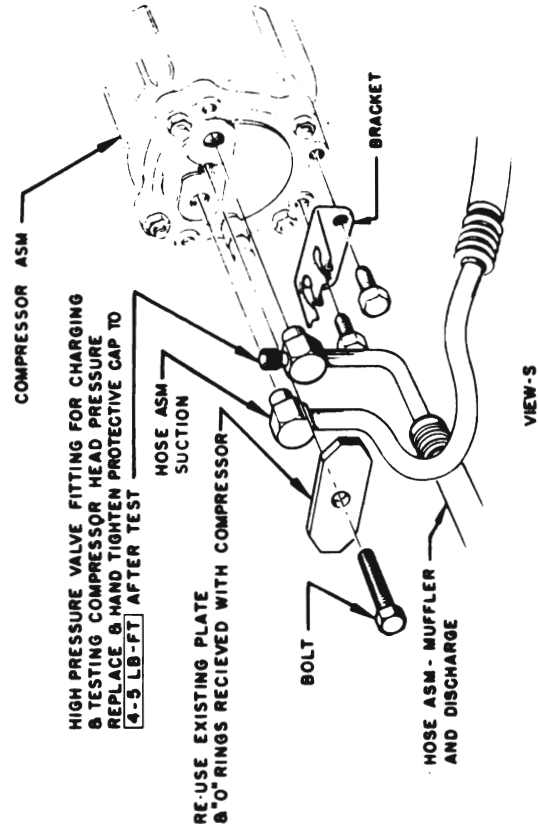

HIGH PRESSURE VALVE FITTING FOR CHARGING & TESTING COMPRESSOR HEAD PRESSURE
 REPLACE & HAND TIGHTEN PROTECTIVE CAP TO 4-5 LB-FT AFTER TEST

RE-USE EXISTING PLATE & O-RINGS RECEIVED WITH COMPRESSOR

REFRIGERANT LINES TO BE ASSEMBLED WITH NO TWIST AND TO HAVE NO DIRECT CONTACT WITH SHEET METAL OR EACH OTHER
 USE OIL ON ALL JOINTS AND O-RING GASKETS FOR EASE OF ASSEMBLY

13-375B

Figure 13-60 Refrigerant Line Installation, 49000 Series

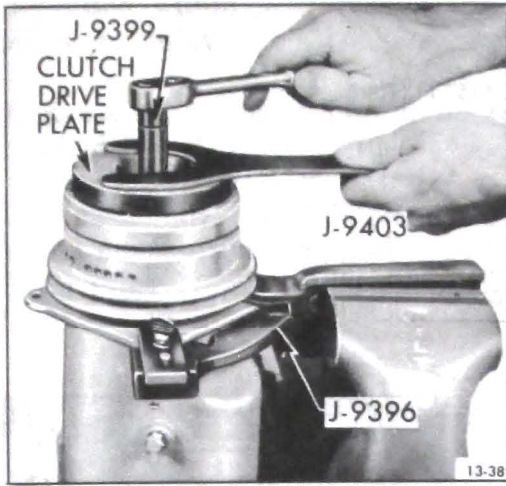

Figure 13-61 Removing or Installing Shaft Nut

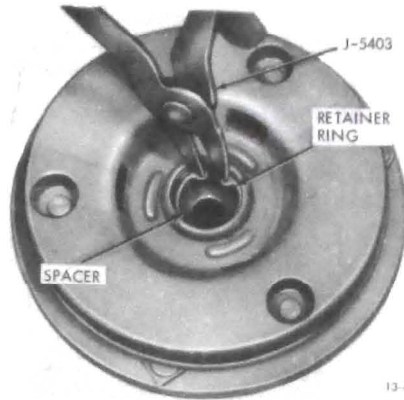

Figure 13-63 - Removing or Installing Retainer Ring in Clutch Drive Plate

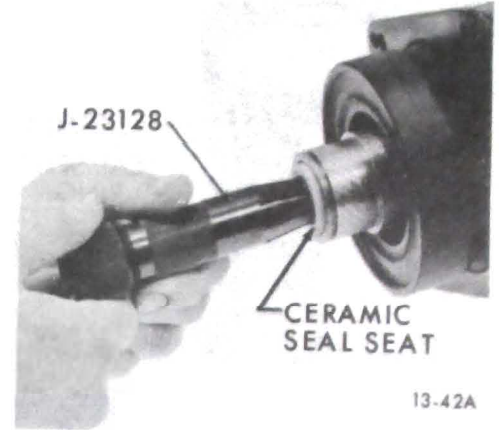

Figure 13-65 Removing or Installing Ceramic Shaft Seal Seat

6. Thoroughly clean the area inside the compressor neck surrounding the shaft, the exposed portion of the seal seat and the shaft itself of any dirt or foreign material. This is absolutely necessary to prevent any such material from getting into the compressor.

7. Remove the seal seat (see Figure 13-65) using Tool J-23128. Insert Tool J-23128 into seal seat and tighten, using a twisting motion remove the seal seat.

8. Remove the seal assembly, using Tool J-9392. Press tool downward on seal while twisting it clockwise to engage the tabs of the seal assembly.

Gently but firmly, pull tool straight out (see Figure 13-66).

9. Remove the seal seat "O" ring, using Tool J-9553 (see Figure 13-67).

10. Re-check the inside of the compressor neck and the shaft. Be sure these areas are perfectly clean before installing new parts.

b. Reassembly

1. Coat the new seal seat "O" ring with clean refrigeration oil and install it in its groove in the compressor neck. Tool J-21508 may be used to accomplish this (see Figure 13-68).

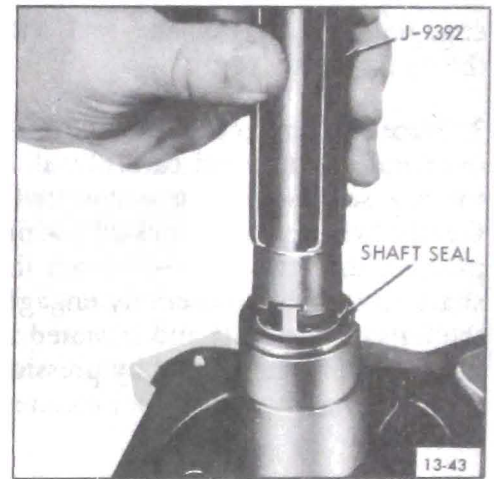

Figure 13-66 Removing or Installing Shaft Seal

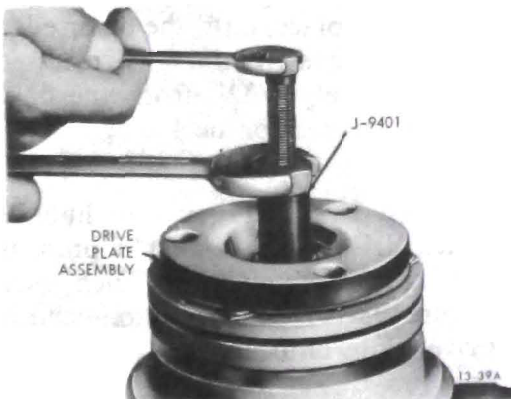

Figure 13-62 Removing Clutch Drive Plate

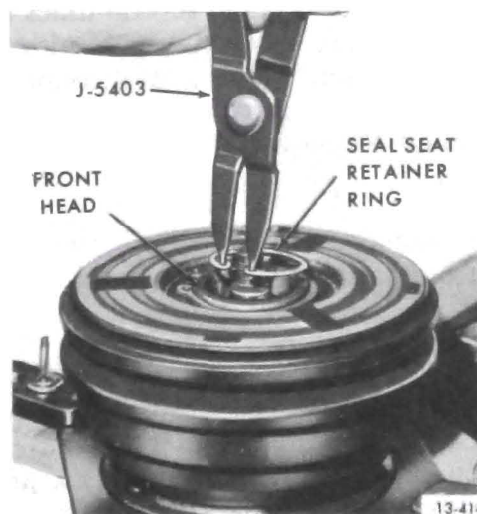

Figure 13-64 Removing or Installing Shaft Seal Seat Retaining Ring

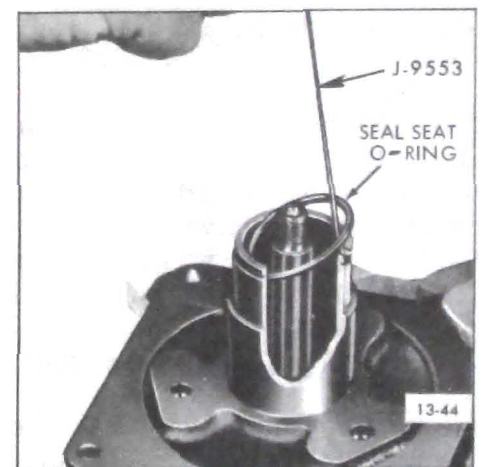

Figure 13-67 Removing Seal Seat 'O' Ring

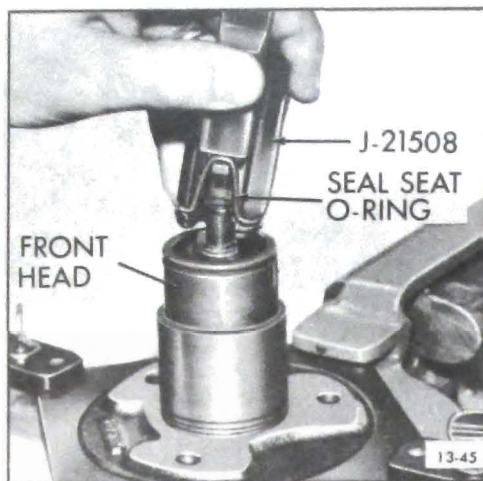

Figure 13-68 Installing Seal Seat 'O' Ring

2. Coat the "O" ring and seal face of the new seal assembly with clean refrigeration oil. Carefully mount the seal assembly to Tool J-9392 by engaging the tabs of the seal with the tangs of the tool.

3. Place seal protector, Tool J-22974, over end of shaft and carefully slide the new seal assembly onto the shaft. Gently twist the tool clockwise while pushing the seal assembly down the shaft until the seal assembly engages the flats on the shaft and is seated in place. Disengage the tool by pressing downward and twisting tool counter-clockwise.

4. Coat the seal face of the new seal seat with clean refrigeration oil. Mount the seal seat on Tool J-9393 and install it in the compressor neck, taking care not to dislodge the seal seat "O" ring and being sure the seal seat makes a good seal with the "O" ring.

5. Install the new seal seat retainer ring with its flat side against the seal seat, using No. 21 Truarc pliers (J-5403). Use the sleeve from Tool J-9393 to press in on the seal seat retainer ring so that it snaps into its groove. Remove seal protector J-22974 from the end of the shaft.

6. Install Compressor Leak Test Fixture (J-9625) on rear head of compressor and connect gage charging lines as shown in Figure 13-69. Pressurize suction side of compressor

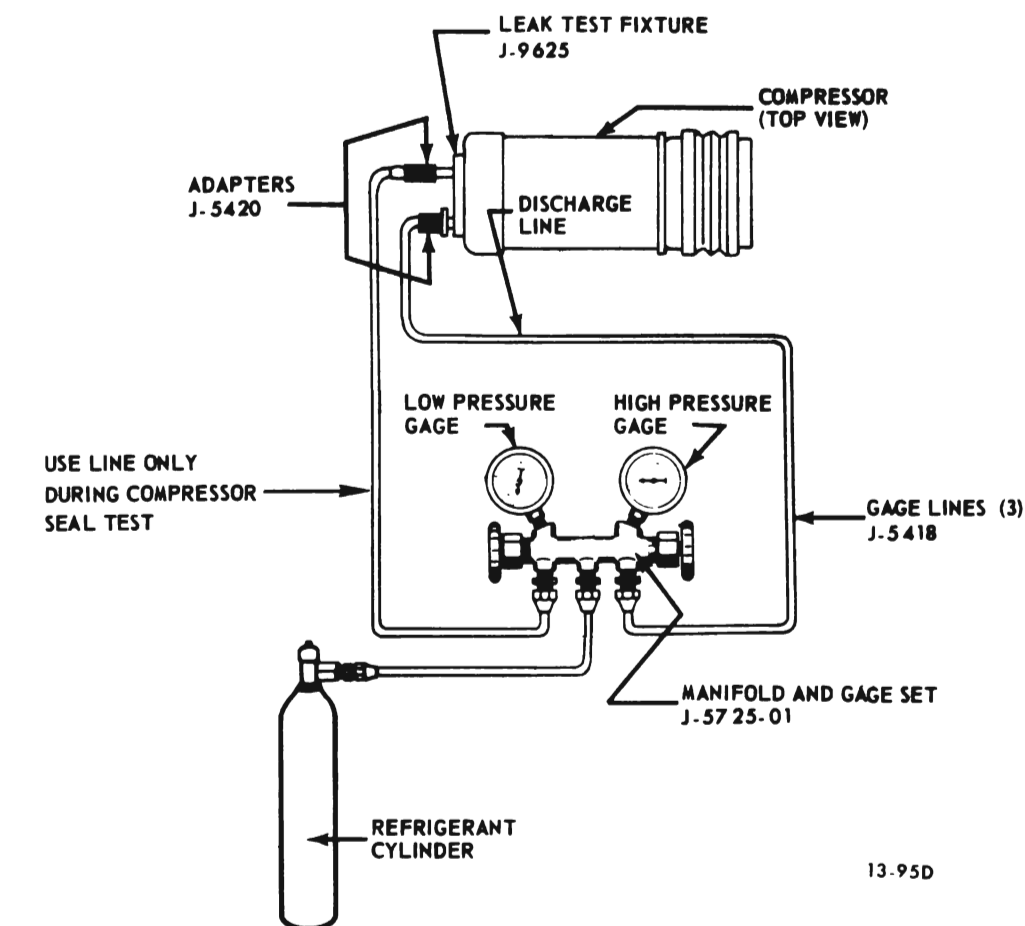

Figure 13-69 Leak Testing Shaft Seal and Seal Seat 'O' Ring

with Refrigerant-12 vapor to drum pressure. Temporarily install the shaft nut and, with compressor horizontal and oil sump down, rotate the compressor shaft in normal direction of rotation several times by hand. Leak test the seal with a propane torch type leak detector in good condition. Correct any leak found. Remove and discard the shaft nut.

7. Remove any excess oil, resulting from installing the new seal parts, from the shaft and inside the compressor neck.

8. Install the new absorbent sleeve by rolling the material into a cylinder, overlapping the ends, and slipping it into the compressor neck with the overlap at the top of the compressor. Using a small screwdriver or similar instrument, care-

fully spread the sleeve so that in its final position, the ends butt together at the top vertical centerline. Install the new sleeve retainer so that its flange face will be against the front end of the sleeve. Using the sleeve from Tool J-9393, press and tap with a mallet, setting the retainer and sleeve into place, until the outer edge of the sleeve retainer is recessed approximately 1/32" from the face of the compressor neck.

9. Insert woodruff key into hub of clutch drive plate so that it projects out approximately 3/16 inch (see Figure 13-70) and position clutch drive plate onto shaft.

10. Using drive plate installer (J-9480), screw installer on end of shaft as shown in Figure 13-71. Hold nut and turn bolt until clutch drive plate

is pressed within $3/32$ inch of the pulley assembly.

11. Reassembly spacer into hub of clutch drive plate.

12. Reassemble retainer ring into hub of clutch drive plate (see Figure 13-62) using No. 21 truarc pliers (J-5403).

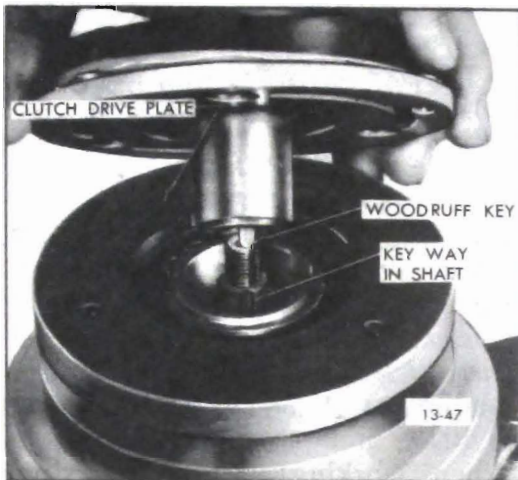

Figure 13-70 Positioning Clutch Drive Plate on Shaft

13. Thread on new shaft nut using special thin wall $9/16$ inch socket (J-9399) and $3/8$ inch drive. Hold clutch drive plate secure using Wrench (J-9403) and torque nut to 15 lb. ft. The air gap between the friction surfaces of the pulley assembly and clutch drive plate should be approximately $1/32$ to $1/16$ inch (see Figure 13-72).

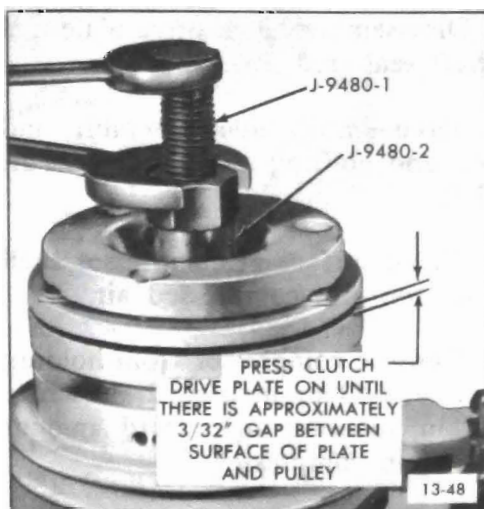

Figure 13-71 Installing Clutch Drive Plate



Figure 13-72 Torquing Shaft Nut

13-21 DISASSEMBLY AND REASSEMBLY OF PULLEY ASSEMBLY, AND COIL AND HOUSING ASSEMBLY

NOTE: It is not necessary to remove the compressor assembly or disconnect refrigerant lines to perform the following operations. However, it is necessary to position the compressor out of the mounting brackets for tool clearance.

a. Disassembly

1. Disassemble clutch drive plate (ref. par. 13-20).

2. Using No. 26 Truarc pliers (J-6435) remove bearing to head retainer ring (see Figure 13-76).

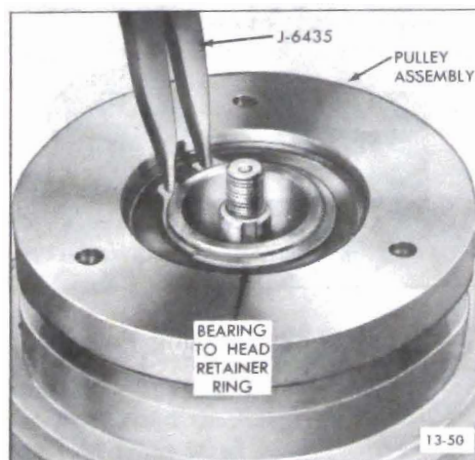

Figure 13-76 Removing or Installing Bearing to Head Retainer Ring

3. Place puller pilot (J-9395) on hub of front head and take off pulley assembly (see Figure 13-77), using pulley puller (J-8433).

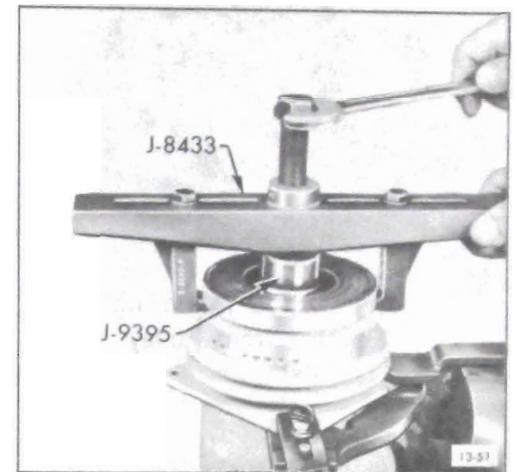

Figure 13-77 Removing Pulley Assembly

CAUTION: Puller pilot (J-9395) must be used. If force is exerted on shaft, damage will result to the internal parts of the compressor.

4. Remove bearing to pulley retaining ring with a small screwdriver (see Figure 13-78).

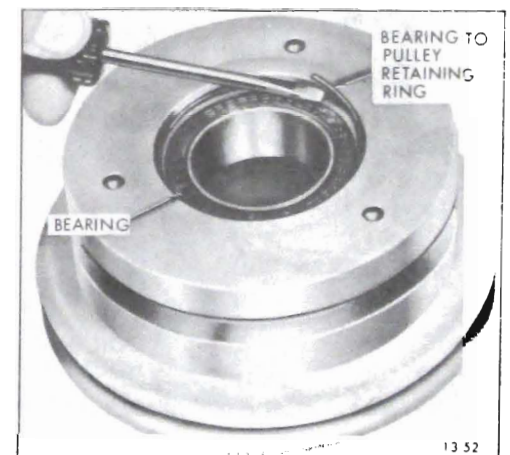

Figure 13-78 Removing Pulley Bearing Retainer

5. Drive out bearing (see Figure 13-79) by use of puller Pilot (J-9398) and Handle (J-8092).

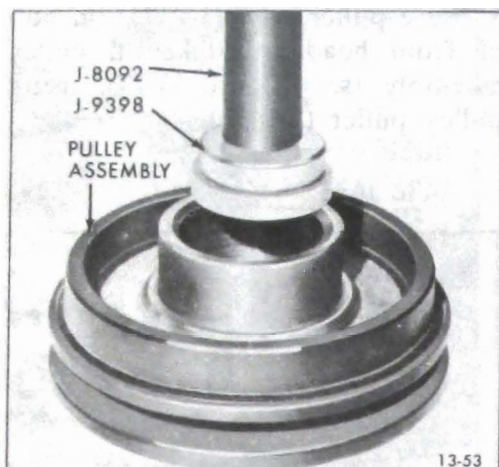

Figure 13-79 Removing Bearing from Pulley Assembly

NOTE: Do not take out pulley bearing unless it is going to be replaced as removal may damage bearing.

6. Mark position of coil and housing assembly in relationship to shell of compressor, remove coil and housing retainer ring (see Figure 13-80) using No. 26 truarc pliers (J-6435), and lift out coil and housing assembly.

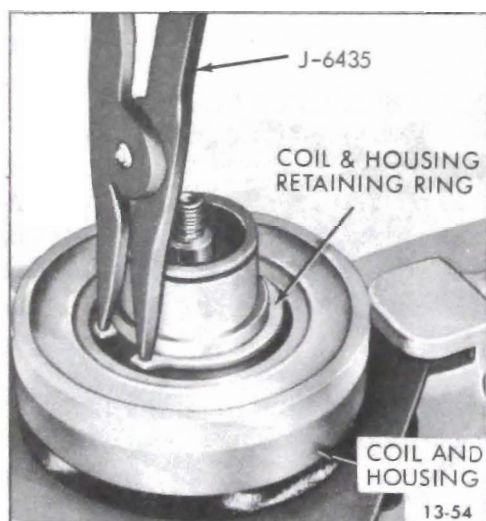

Figure 13-80 Removing or Installing Coil and Housing Retainer Ring

b. Reassembly

1. Reassemble coil and housing assembly reverse of disassembly.

2. Drive new bearing into pulley assembly (see Figure 13-81) with installer (J-9481) and handle (J-8092).

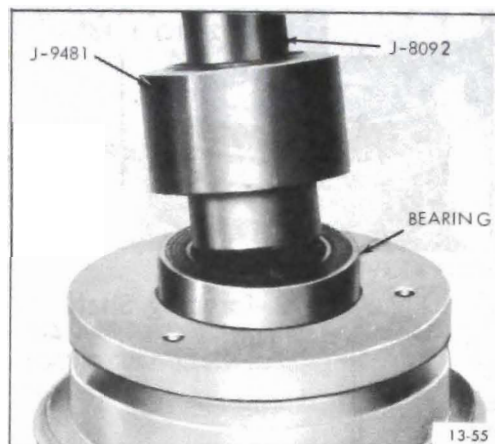

Figure 13-81 Installing Bearing into Pulley Assembly

3. Lock bearing in position with bearing to pulley retainer ring (see Figure 13-78).

4. Drive pulley assembly onto hub of front head (see Figure 13-82) using installer (J-9481) and handle (J-8092).

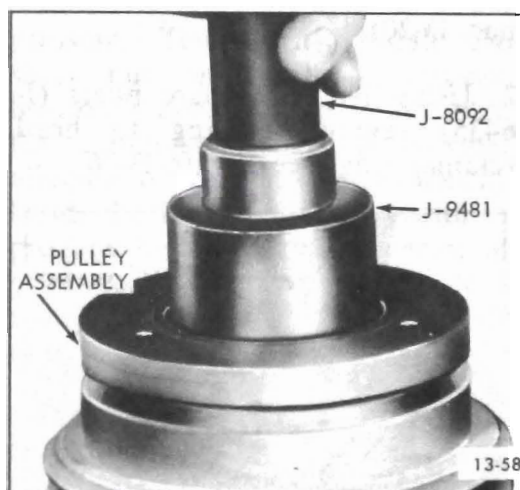

Figure 13-82 Installing Pulley Assembly

NOTE: If the pulley assembly is going to be reused, clean the friction surface with trichlorethylene, alcohol, or a similar solvent.

5. Lock pulley assembly in position with bearing to head retainer ring (flat side of retainer ring downward) using No. 26 Truarc pliers (J-6435). See Figure 13-76.

6. Reassemble clutch drive plate (refer to paragraph 13-20).

13-22 DISASSEMBLY AND REASSEMBLY OF INTERNAL PARTS OF COMPRESSOR AND LEAK TESTING COMPRESSOR

CAUTION: A clean work area and a place for each part removed is required to properly disassemble and reassemble compressor. The internal parts of the compressor must be kept free of dirt or foreign material.

When working with compressor, under no circumstances should compressor be rested on pulley end.

a. Disassembly of Rear Head, Oil Pump, Rear Discharge Valve Plate, and Rear Suction Valve Reed Disc

NOTE: If compressor is not going to be disassembled any further than removal of rear head, oil pump, rear discharge valve plate, or rear suction valve reed disc, omit Steps '1, 2 and 4'.

1. Disassemble clutch drive plate and shaft seal (ref. Par. 13-20).

2. Disassemble pulley assembly, and coil and housing assembly (ref. Par. 13-21).

3. Clean surface of compressor shell and dry with compressed air.

4. Remove compressor from holding fixture (J-9396), unscrew drain screw. Drain, measure and record amount of oil in compressor.

5. Reinstall compressor in holding fixture (J-9396) positioned as shown in Figure 13-83.

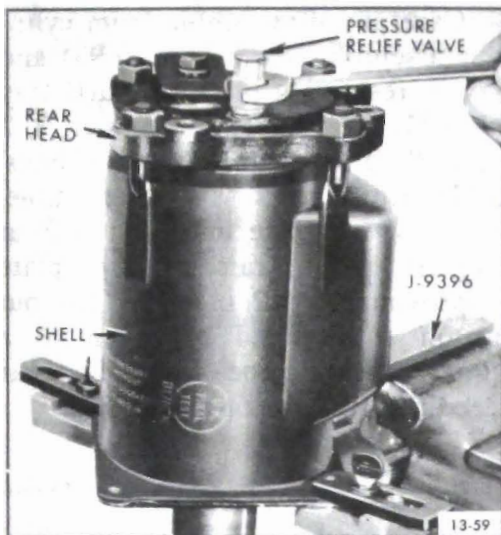

Figure 13-83 Compressor Installed in Holding Fixture

6. Unscrew and discard four lock nuts from rear of compressor, and lift off rear head by tapping it with a mallet.

NOTE: If Teflon sealing surface is damaged (see Figure 13-84), replace rear head. Clean or replace suction screen as necessary.

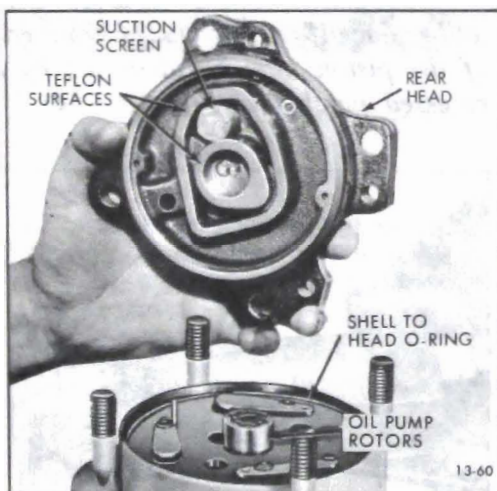

Figure 13-84 Rear Head Removal

7. Pencil mark top side of both oil pump rotors and lift out rotors.

NOTE: Replace both oil pump inner and outer rotors if one or both are damaged or worn.

8. Take out and discard shell to head "O" ring.

9. Carefully pry out rear discharge valve plate and rear suction valve reed disc with screwdrivers (see Figure 13-85 and 13-86). Check both pieces and replace as necessary.

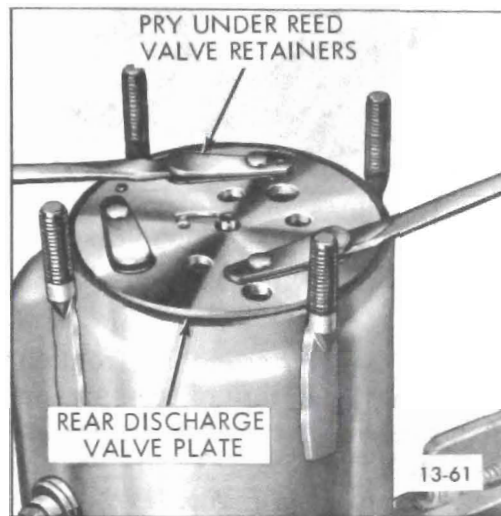

Figure 13-85 Removing Rear Discharge Valve Plate

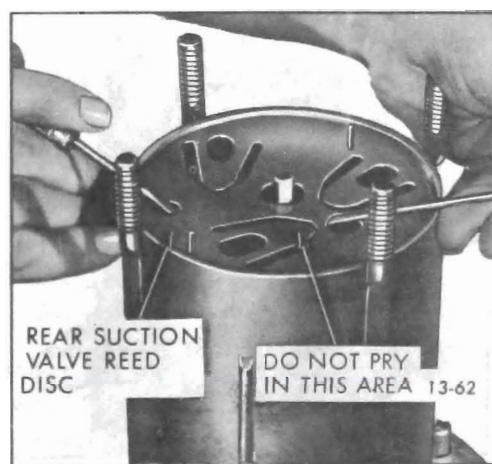

Figure 13-86 Removing Rear Suction Valve Reed Disc

NOTE: During disassembly, the disc generally adheres to the plate and both pieces lift out together.

b. Removing Cylinder Assembly, and Disassembly of Front Suction Valve Reed Disc, Front Discharge Valve Plate, and Front Head

1. Pull out oil inlet tube (see Figure 13-87) and oil inlet tube "O" ring using Remover (J-6586).

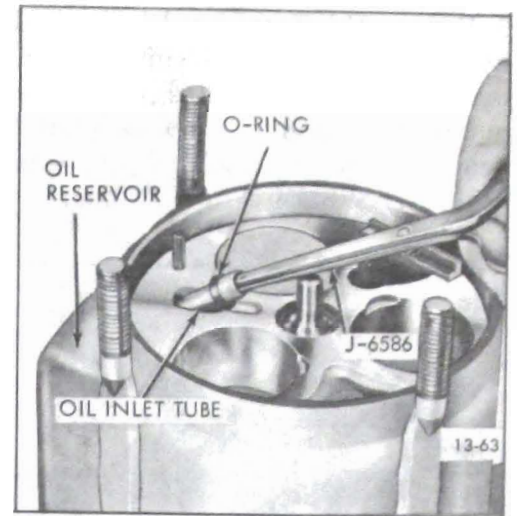

Figure 13-87 Removing Oil Inlet Tube

2. Push shaft upward from front head and lift out cylinder assembly (see Figure 13-88), front suction valve reed disc, and front discharge valve plate.

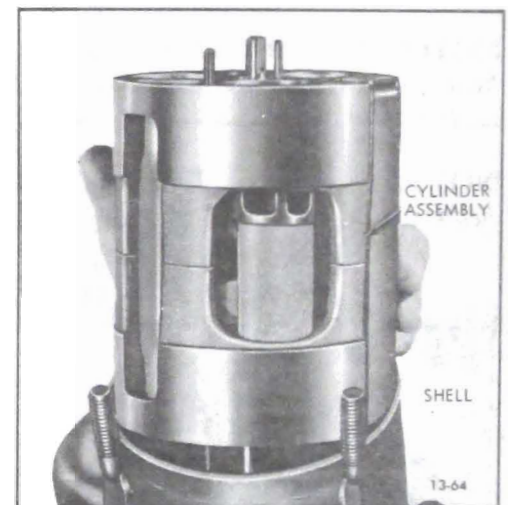

Figure 13-88 Removing Internal Cylinder Assembly

NOTE: When lifting out the cylinder assembly, the front suction valve reed disc and the front discharge valve plate generally adhere to the cylinder assembly and lift out with it. Check and replace if necessary.

Depending on wear or damage to cylinder assembly, it may be advisable to replace complete cylinder assembly. If service replacement cylinder is used omit following steps and continue on with subparagraph entitled "FINAL REASSEMBLY OF CYLINDER ASSEMBLY".

13-50 HEATER-AIR CONDITIONING SYSTEM

3. Disassemble front head from shell by tapping front head with a mallet to unseat head, and lifting straight out through rear of shell the front head and shell to head "O" ring (see Figure 13-89). Discard "O" ring.

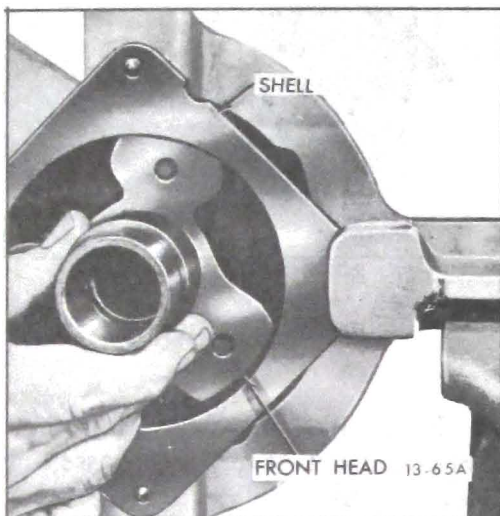

Figure 13-89 Removing Front Head

NOTE: If sealing surfaces of front head (see Figure 13-90) are damaged, replace front head.

NOTE: There is no Teflon on front head sealing surface.

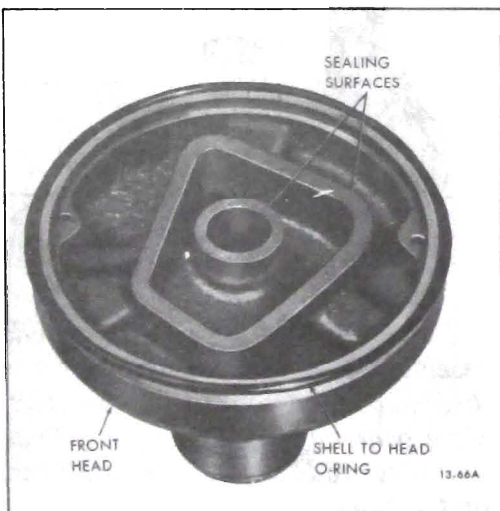

Figure 13-90 Front Head Sealing Surfaces

c. Disassembly of Cylinder Assembly

1. Pry off suction pass cover using screwdriver (see Figure 13-91).

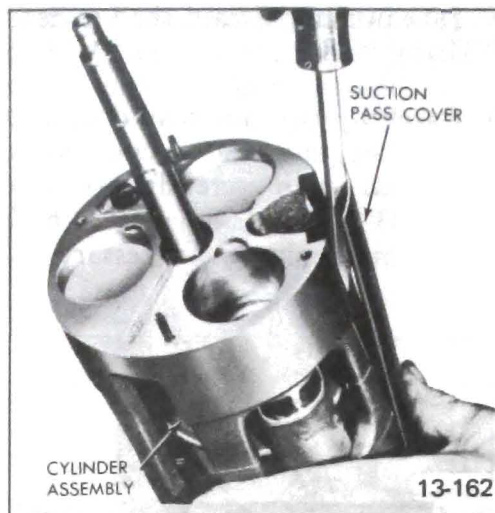

Figure 13-91 Removing Suction Pass Cover

2. Place cylinder assembly (front end downward) on top of compressing fixture (J-9397), number pistons and cylinders "1, 2 and 3" to facilitate reassembly (see Figure 13-92), and separate cylinder halves using a hard rubber mallet or hammer and wood block.

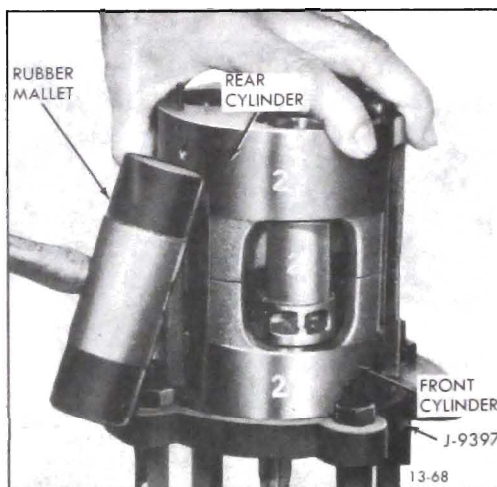

Figure 13-92 Separating Cylinder Halves

3. Disassemble rear cylinder half and discharge tube from cylinder assembly and discard discharge tube.

NOTE: Depending on whether or not discharge tube comes out with rear cylinder half or remains in front cylinder half it may be necessary to rotate shaft and swash plate assembly (using 9/16 inch opened wrench on shaft seal portion of shaft) to achieve necessary clearance.

4. Carefully disassemble from cylinder assembly (see Figure 13-93) and lay in respective place on parts tray (J-9402) the following: number "1, 2 and 3" pistons, piston drive balls, and piston rings. To disassemble, rotate swash plate until piston is at highest point, raise swash plate approximately 1/2 inch and lift out piston and related parts one at a time. Discard shoe discs and rear needle thrust bearing and races.

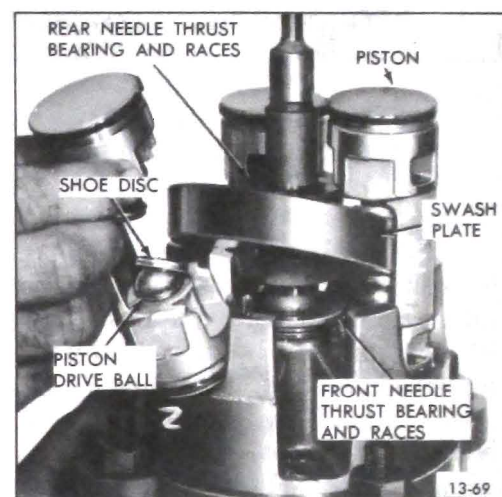

Figure 13-93 Disassembly of Cylinder Assembly

NOTE: Examine piston drive balls and replace if necessary. The front end of the piston may be identified by a recessed notch (see Figure 13-94).

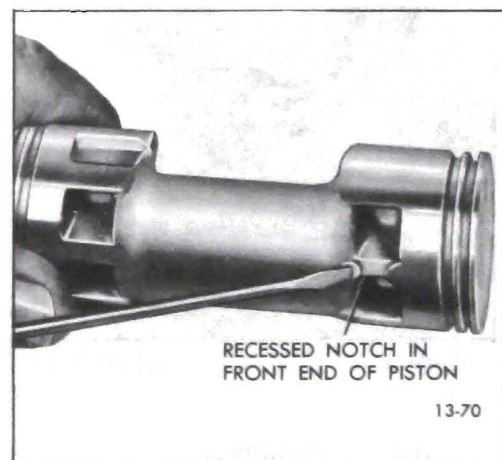

Figure 13-94 Piston Identification

5. Lift out shaft and swash plate assembly and front needle thrust bearing races. Discard front needle thrust bearing and races.

Examine shaft and swash plate assembly and replace as necessary.

6. Wash all salvaged parts of cylinder assembly in bath of trichloroethylene, alcohol, or similar solvent and dry parts with filtered, dry compressed air.

NOTE: Examine front and rear cylinder halves, front and rear main shaft bearings, and replace as necessary.

If bearings are to be replaced, drive out of cylinder halves with suitable socket or punch. Install new bearing (lettering on bearing edge facing outward) using bearing installer (J-9432). See Figure 13-95.

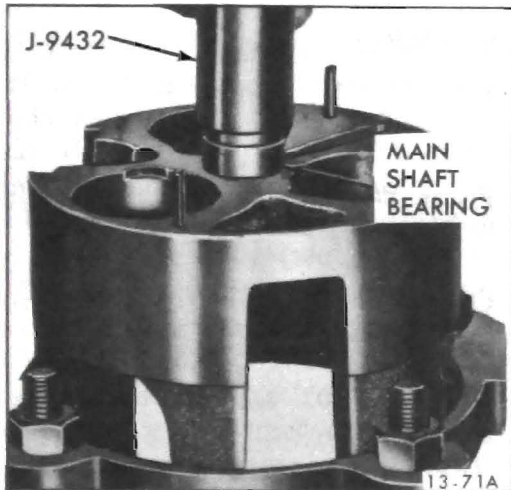

Figure 13-95 Installing Main Shaft Bearing

d. Partial Reassembly of Cylinder Assembly, and Gaging of Piston Play and Shaft End Play

1. Obtain from parts stock four "zero" thrust races, two needle thrust bearings, and three "zero" shoe discs.

2. Place front cylinder on top of compressing fixture (J-9397) as shown in Figure 13-96.

3. Generously coat with clean petroleum jelly two "zero" thrust races, and a new needle thrust bearing. Assemble races and bearing to front end of shaft and swash plate assembly and insert assembly into front cylinder (see Figure 13-96.)

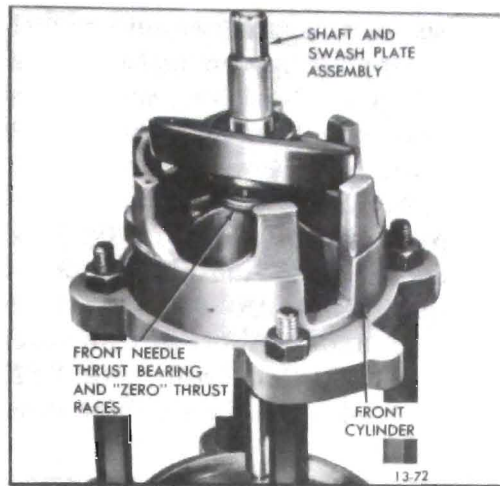

Figure 13-96 Shaft and Front Needle Thrust Bearing in Cylinder Half

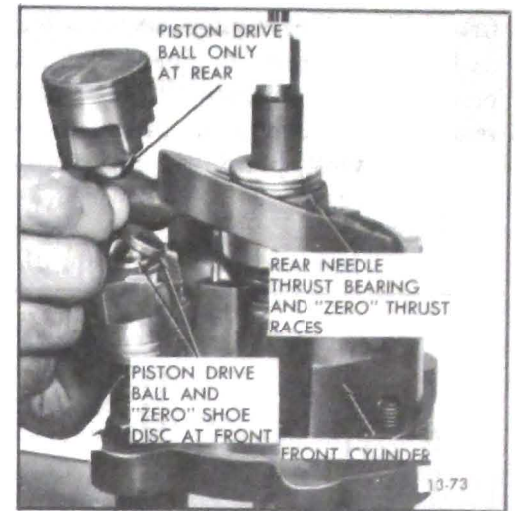

Figure 13-97 Installing Piston into Cylinder Half

4. Assemble two additional "zero" thrust races and a new needle thrust bearing to rear end of shaft and swash plate assembly.

5. Lightly coat ball pockets of the three pistons with clean petroleum jelly and place a piston drive ball in each pocket.

6. Lightly coat the three "zero" shoe discs with clean petroleum jelly and place a disc on only the piston drive ball at the front of each piston.

NOTE: Do not place shoe discs on rear piston drive balls. Do not reassemble piston rings on pistons at this time. Use lubricant in sufficient quantity so that piston drive balls and shoe discs stick to piston.

7. Rotate shaft and swash plate assembly until high point of swash plate is over No. "1" cylinder bore. Position No. "1" piston onto swash plate (see Figure 13-97) and lower the piston and swash plate so the front end (notched end - see Figure 13-97) of the piston enters the cylinder bore.

NOTE: In order to fit the piston onto the swash plate, the shaft and swash plate assembly must be raised approximately 1/2 inch, and also the front needle thrust bearing and races must be held up against the hub of the swash plate.

8. Repeat preceding step for reassembly of pistons No. "2" and No. "3".

9. reassemble rear cylinder onto front cylinder using wood block and mallet (see Figure 13-98).

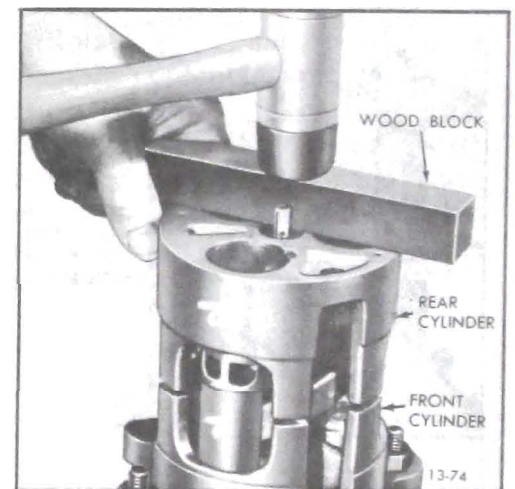

Figure 13-98 Assembling Rear Cylinder Half

10. Remove cylinder assembly from on top of compressing fixture (J-9397), position assembly inside fixture so that discharge tube opening in cylinder halves is located between fixture legs, and front of cylinder assembly is downward. Install and torque fixture nuts to 15 lb. ft.

11. Gage piston play as follows:

13-52 HEATER-AIR CONDITIONING SYSTEM

(a) Using a feeler gage, select a leaf or combination of leaves which result in satisfactory "feel" when inserted between rear piston drive ball and swash plate (see Figures 13-99 and 13-100).

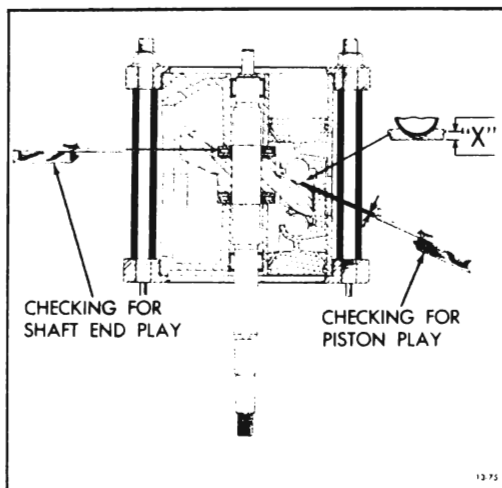

Figure 13-99 Checking Piston and Shaft End Play

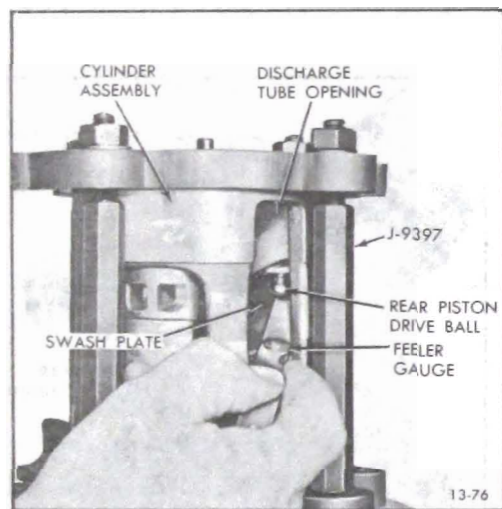

Figure 13-100 Checking Clearance Between Rear Piston Drive Ball and Swashplate.

(b) Remove selected leaf or leaves from feeler gage and attach end of spring scale that is calibrated in ounces. (A generator brush spring scale (J-5184) or the spring scale for checking distributor point setting may be used for this step).

(c) Reinsert feeler gage leaf or leaves between rear piston drive ball and swash plate and draw leaf or

leaves out again, simultaneously measuring "drag" on leaf or leaves (see Figure 13-104). If correct leaf (leaves) has been selected, spring scale will read between 4 to 8 ounces pull (the higher reading is desired). To perform this step correctly, feeler gage leaf (leaves) must be withdrawn straight out with a steady even motion, and all surfaces involved must be coated with No. 525 viscosity oil. Record gage dimension.

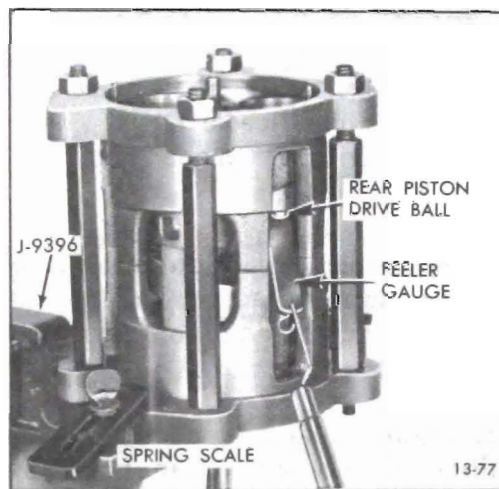

Figure 13-104 Checking 'Drag' on Selected Feeler Gage Leaf with Spring Scale

NOTE: Use of the spring scale establishes a standard of measurement of the amount of feeler gage leaf 'drag' required.

(d) Rotate the shaft and swash plate assembly 120 degrees and perform a second check (Steps "a, b and c") between same piston drive ball and swash plate. Record gage dimension.

(e) Rotate shaft and swash plate again approximately 120 degrees and repeat third check (Steps "a, b and c") between same piston drive ball and swash plate. Record gage dimension.

(f) From the three recorded checks (Steps "c, d and e") select minimum feeler gage reading and obtain from stock (ref. Figure 13-105 for part number of shoe disc) one shoe disc corresponding to the minimum gage reading (ref. example below). Place

shoe disc in respective position on parts tray (J-9402).

SERVICE PART NO.	IDENTIFICATION NO. STAMPED SHOE DISC
6557000	0 ("ZERO" SHOE DISC)
6556175	17½
6556180	18
6556185	18½
6556190	19
6556195	19½
6556200	20
6556205	20½
6556210	21
6556215	21½
6556220	22

Figure 13-105 Shoe Disc Table

EXAMPLE

1st 2nd 3rd
check check check

Piston #1 .019 .020 .019 (Select No. 19 shoe disc)

Piston #2 .020 .020 .020 (Select No. 20 shoe disc)

Piston #3 .021 .020 .021 (Select No. 20 shoe disc)

(g) Repeat Steps "c, d, e and f" for other two pistons and obtain two more selected shoe discs for other two pistons.

NOTE: In the rebuilt cylinder assembly, each piston will have one selected shoe disc and one 'zero' shoe disc.

12. Gage shaft end play as follows:

(a) Using a feeler gage, select a leaf or combination of leaves which result in satisfactory "feel" when inserted between rear needle thrust bearing and outer rear thrust race (see Figure 13-106).

(b) Remove selected leaf or leaves from feeler gage. Attach to end of spring scale calibrated in ounces. (A generator brush spring scale (J-5184) or the spring scale for checking distributor point setting may be used for this step).

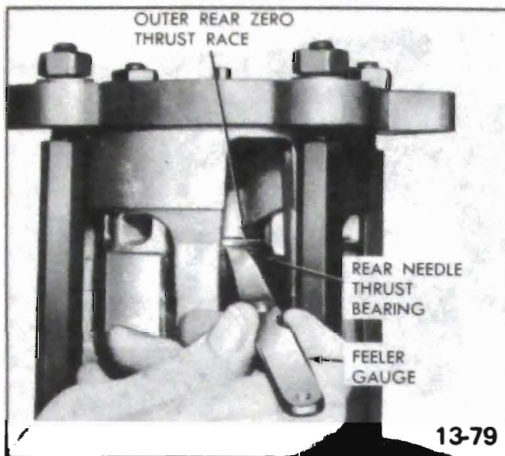

Figure 13-106 Gaging Clearance Between Rear Needle Thrust Bearing and Outer Rear Thrust Race

(c) Reinsert feeler gage leaf (leaves) between rear needle thrust bearing and outer rear thrust race and draw leaf (leaves) out again, this time simultaneously noting the "drag" or pull on the leaf (leaves) as measured by the spring scale (see Figure 13-107). If correct leaf (leaves) have been selected, spring scale will read between 4 to 8 ounces pull (the higher reading is desired). To perform this step correctly, the feeler gage leaf (leaves) must be withdrawn straight out with a steady, even motion. All contacting surfaces involved in gaging operation must be coated with No. 525 viscosity oil.

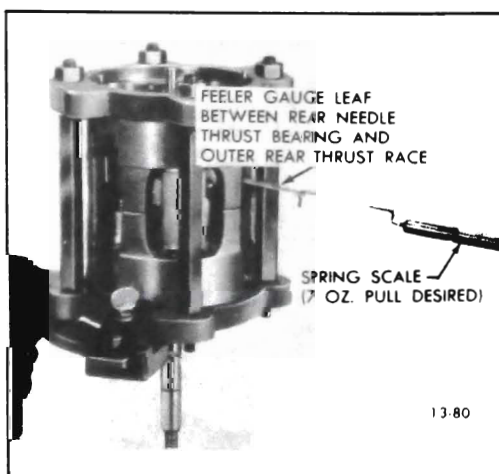

Figure 13-107 Checking 'Drag' on Selected Feeler Gage Leaf with Spring Scale

NOTE: The measurement for selection of the thrust race needs to be performed at only one place on the shaft and swash plate assembly.

(d) Select from stock one thrust race (ref. Figure 13-108 for part number of thrust race) corresponding to the feeler gage reading determined in Step "c", and place the selected thrust race in the parts tray slot designated for the outer rear thrust race. If, for example a feeler gage reading of 0.009 inch results, a thrust race with a number "9", stamped on it should be selected.

SERVICE PART NO.	IDENT. NO. ON RACE	THICKNESS
6556000	0	.0920
6556050	5	.0965
6556055	5½	.0970
6556060	6	.0975
6556065	6½	.0980
6556070	7	.0985
6556075	7½	.0990
6556080	8	.0995
6556085	8½	.1000
6556090	9	.1005
6556095	9½	.1010
6556100	10	.1015
6556105	10½	.1020
6556110	11	.1025
6556115	11½	.1030
6556120	12	.1035

Figure 13-108 Thrust Race Table

NOTE: The selected thrust race will replace only the 'zero' outer rear thrust race. The remaining three 'zero' thrust races will remain as part of the cylinder assembly.

13. Remove cylinder assembly from inside compressing fixture (J-9397), place on top of compressing fixture (see Figure 13-96) and disassemble rear cylinder from front cylinder using rubber mallet or hammer and wood block.

14. Carefully disassemble one piston at a time from front cylinder and lay piston, front and rear piston drive balls and front "zero" shoe disc in respective slot of parts tray (J-9402). To disassemble, rotate swash plate until piston is at highest point, raise swash plate approximately 1/2 inch and lift out piston and related parts, one at a time.

15. Remove outer rear "zero" thrust race from shaft and set it aside for future gaging procedures.

16. Remove previously selected outer rear thrust race from parts tray, lightly coat with clear petroleum jelly and assemble onto shaft.

e. Final Reassembly of Cylinder Assembly

1. Reassemble piston rings onto pistons (ring scraper groove toward center of piston) and rotate ring so that break or gap in ring can be squeezed together when piston is being inserted into cylinder bore.

2. Reassemble piston drive balls, "zero" and selected shoe discs onto No. "1" piston, and apply clear petroleum jelly to piston pockets and shoe discs so that balls and discs stick to piston.

NOTE: BE SURE to reassemble balls and shoe discs into their specific positions on front and rear of piston.

3. Rotate shaft and swash plate assembly until high point of swash plate is over No. "1" cylinder bore. Position No. "1" piston onto swash plate (see Figure 13-109) and lower the piston and swash plate so that the front end (notched end) of the piston enters the cylinder bore.

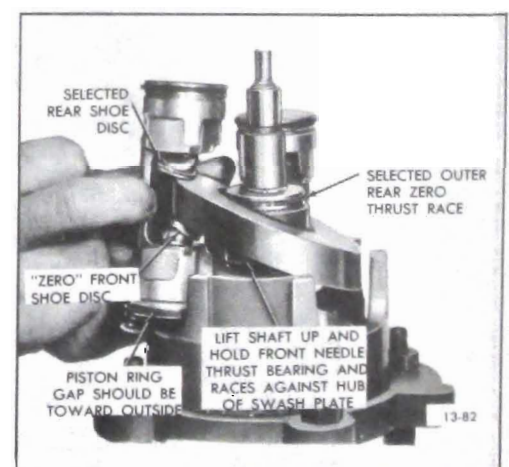

Figure 13-109 Installing Piston Assembly in Front Cylinder Half

NOTE: In order to fit the piston onto the swash plate and into the cylinder bore, the swash plate must be raised approximately 1/2 inch, the front needle thrust bearing and races must be held up against the hub of the swash plate, and the piston rings must be squeezed together (see Figure 13-110). Lubricate cylinder bore, piston assembly and swash plate with No. 525 viscosity oil to facilitate reassembly.

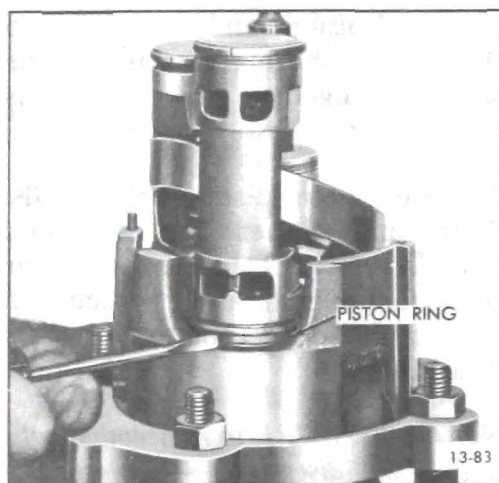

Figure 13-110 Compressing Front Piston Rings

4. Repeat procedure in Steps 1 and 2 for installation of No. 2 and No. 3 pistons.

5. Obtain new service replacement discharge tube and assemble into front cylinder (see Figure 13-111).

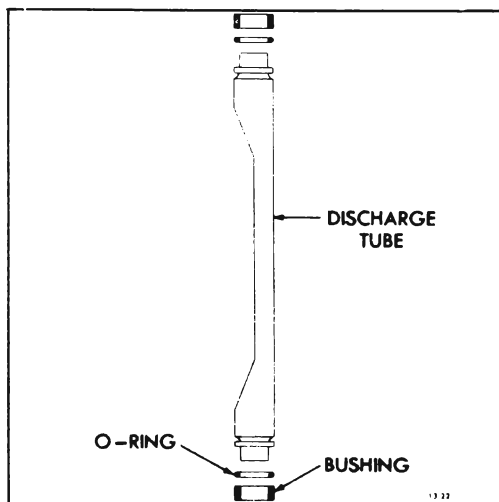

Figure 13-111 Service Replacement Discharge Tube

6. Liberally lubricate cylinder bores of rear cylinder with No. 525 viscosity oil and reassemble rear cylinder onto front cylinder being sure to compress piston rings. Align discharge tube and dowel pins, and tap cylinder halves together. Check for free rotation of shaft.

NOTE: If pistons are positioned in a 'stair-step' arrangement (see Figure 13-112), installation of rear cylinder will be facilitated. In addition once the piston and ring are started into the cylinder, slight rotation of the shaft to and fro will work the ring into the bore.



Figure 13-112 Pistons Positioned in 'Stair-Step' Arrangement

7. Liberally lubricate with No. 525 viscosity oil, suction pass cover and lips of suction passage in body of cylinder assembly, and reassemble suction pass cover over suction passage (see Figure 13-113).

8. Assemble both service replacement discharge tube "O" rings and bushings (see Figure 13-114) onto cylinder assembly.

f. Reassembly of Front Suction Valve Reed Disc, Front Discharge Valve Plate, Front Head, and Installing of Cylinder Assembly

1. Assemble suction reed valve disc to front of cylinder assembly and align with dowel pins, suction port and discharge port (see Figure 13-115).



Figure 13-113 Installing Suction Pass Cover



Figure 13-114 Installing Discharge Tube 'O' Ring and Bushing

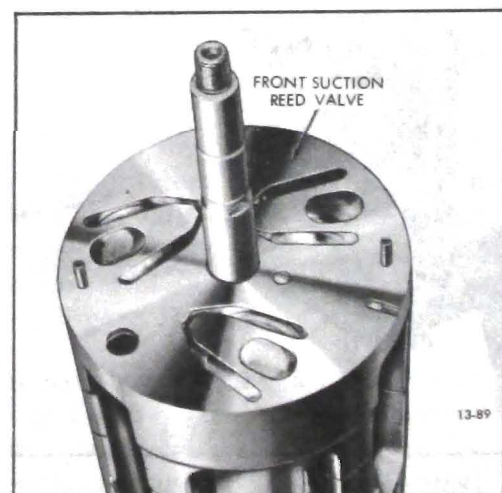

Figure 13-115 Front Suction Valve Reed Disc Installed

2. Assemble front discharge valve plate to front of cylinder assembly and align with dowel pins.

3. Coat sealing surfaces on front head (see Figure 13-116) with No. 525 viscosity oil.

4. Mark with pencil on side of front head the location of dowel pin holes (see Figure 13-116), align front head with dowel pins, and tap head lightly with mallet to seat on cylinder assembly.



Figure 13-116 Placing Front Head on Cylinder Assembly

5. Place new shell to head "O" ring on shoulder of front head (see Figure 13-117) and liberally coat "O" ring and front head sealing surface with No. 525 viscosity oil.



Figure 13-117 Shell to Front Head 'O' Ring Installation

6. Install shell in holding fixture (J-9396) and position so that rear studs of shell are up. Coat inside surface of shell with No. 525 viscosity oil.

7. Reassemble, as a unit, cylinder assembly and front head into the shell (see Figure 13-118).

NOTE: *Extreme care must be used to prevent shell to head 'O' ring seal from being damaged.*

g. Reassembly of Rear Suction Valve Reed Disc, Rear Discharge Valve Plate, Oil Pump and Rear Head

1. Rotate the cylinder assembly and front head until the hole for the oil inlet tube in the cylinder assembly is aligned with the reservoir hole in the shell, and reassemble the oil inlet tube and "O" ring.

2. Assemble suction reed valve disc to rear of cylinder assembly and

align with dowel pins, suction port, and discharge port of cylinder assembly.

3. Assemble rear discharge valve plate to rear of cylinder assembly and align with dowel pins.

4. Reassemble inner and outer oil pump rotors so that the sides previously identified are in their original location, and then position oil pump outer rotor as shown in Figure 13-119.

5. Generously coat with No. 525 viscosity oil new shell to head "O" ring and install in shell (see Figure 13-119).

6. Coat Teflon sealing surface of rear head with No. 525 viscosity oil, mark with pencil on side of rear head the location of the dowel pin holes and reassemble onto compressor.

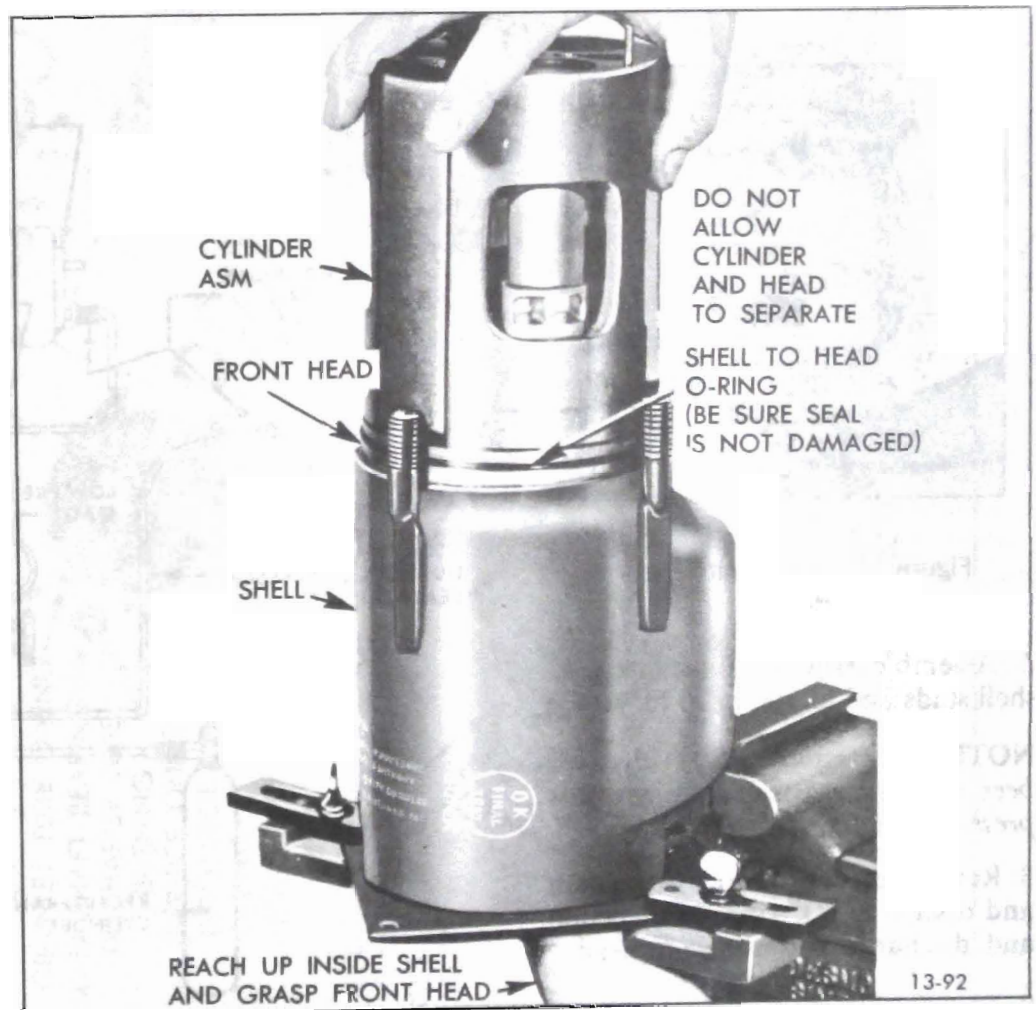

Figure 13-118 Installing Front Head and Cylinder Assembly in Shell

13-56 HEATER-AIR CONDITIONING SYSTEM

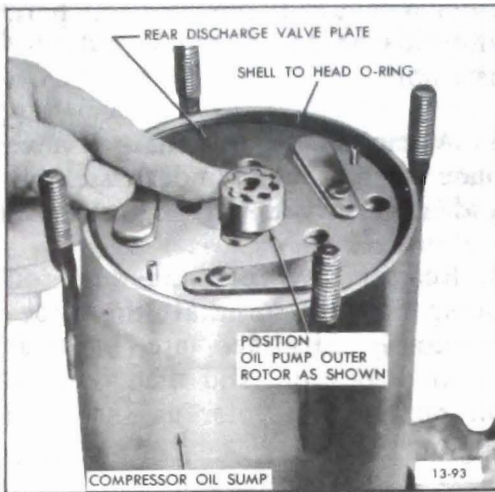

Figure 13-119 Positioning Oil Pump Outer Rotor

NOTE: It may be necessary to reposition oil pump outer rotor slightly in order to install rear head. In addition, if dowel pins do not engage holes in rear head, grasp front head and rotate cylinder assembly slightly (See Figure 13-120).

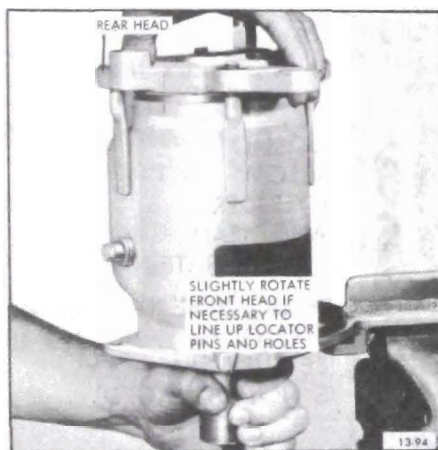

Figure 13-120 Installing Rear Head

7. Assemble new nuts to threaded shell studs and torque to 20 lb. ft.

NOTE: If pressure relief valve has been removed, reassemble using a new pressure relief valve gasket.

8. Reassemble new lubricated suction and discharge "O" rings into suction and discharge ports of rear head.

9. Reassemble shaft seal onto front of shaft and swash plate assembly (ref. Par. 13-20).

NOTE: Do not reassemble clutch drive plate at this time.

h. Leak Testing Compressor

1. After the shaft seal pressure test (ref. Par. 13-20, Step 6) has been performed, change the test circuit to the configuration shown in Figure 13-121.

2. With hose attached only to high pressure side of Leak Test Fixture J-9625, open high pressure valve to charge high pressure side of compressor. As soon as high pressure gage stabilizes reading, close valve. If high pressure gage drops back immediately when valve is closed, an internal leak is indicated. Correct leak as necessary.

NOTE: If an internal leak is indicated, the leak may exist about the head sealing surface or Teflon seal, discharge tube, shell to head 'O' rings, or suction valve reed discs.

3. Remove drain screw from shell and add No. 525 viscosity oil as specified in Par. 13-16.

4. Reassemble pulley assembly, and coil and housing assembly onto hub of front head (ref. Par. 13-21).

5. Complete reassembly by installing clutch drive plate onto hub of front head (ref. Par. 13-20). See Figure 13-122 disassembled view of compressor.

13-23 REMOVAL AND INSTALLATION OF MUFFLER

a. Removal

1. Discharge system (refer to Par. 13-15).

2. Disconnect refrigerant lines connected to muffler and tape closed both open ends of refrigerant lines.

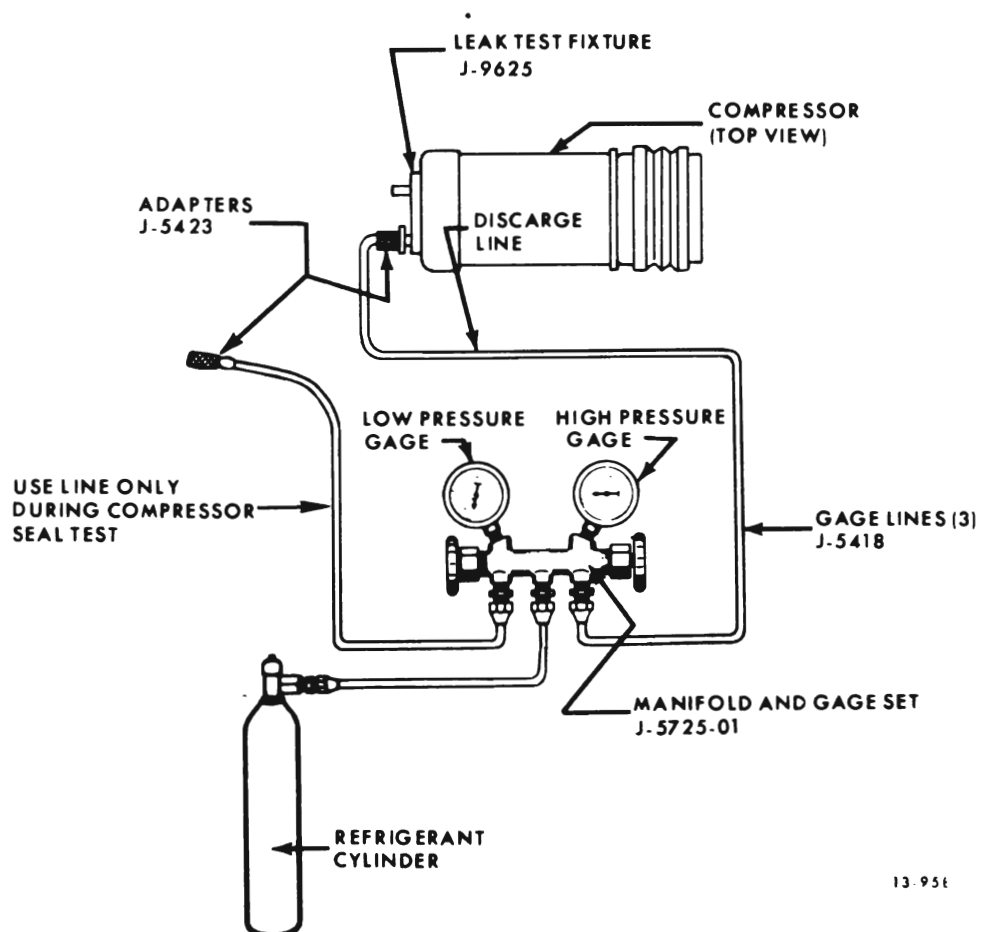
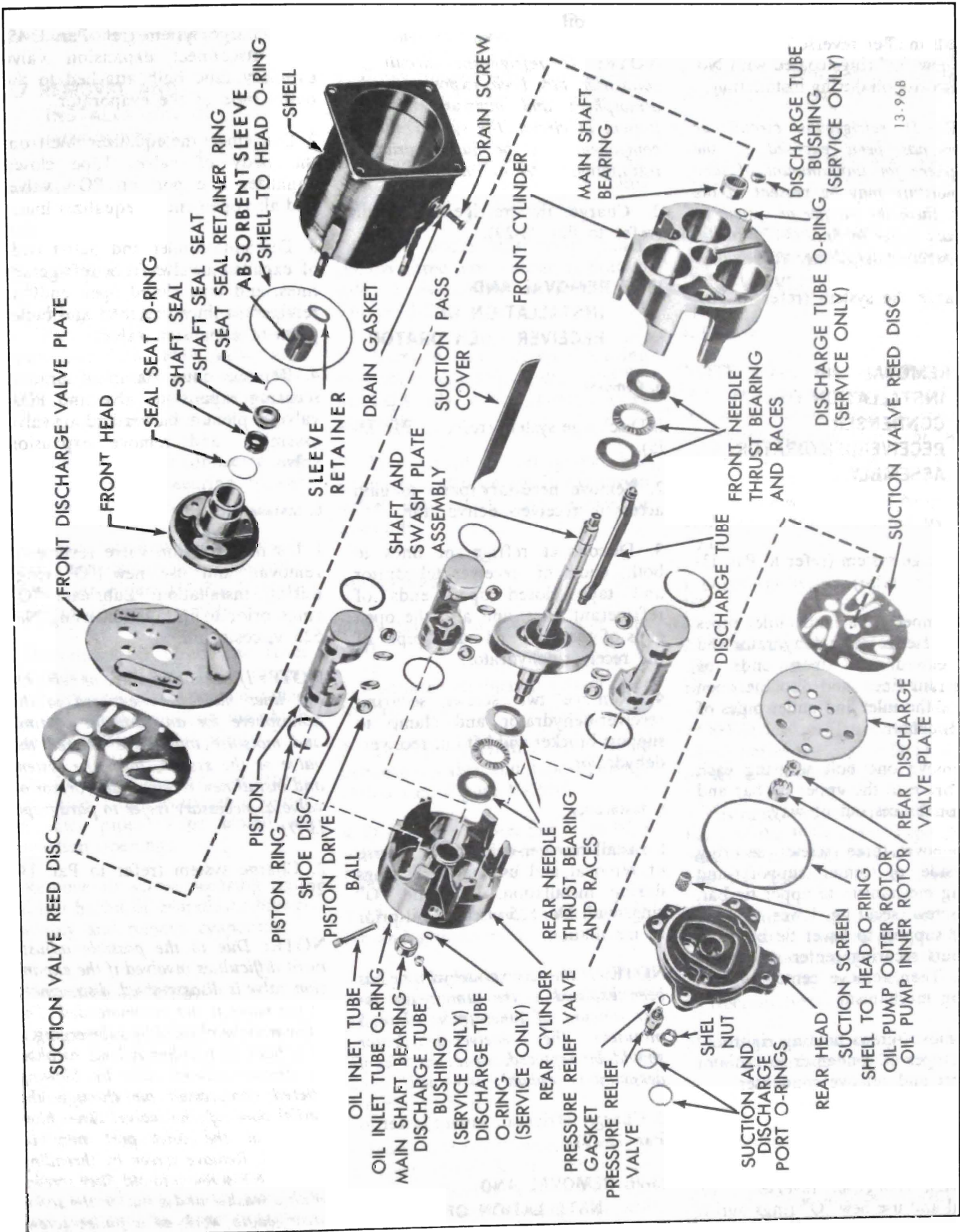

Figure 13-121 Compressor Internal Leak Test



13-968

Figure 13-122 · Compressor · Exploded View

13-58 HEATER-AIR CONDITIONING SYSTEM**b. Installation**

1. Install muffler reverse of removal, using new "O" rings coated with No. 525 viscosity oil during installation.

NOTE: *If refrigerant circuit or muffler has been exposed to the atmosphere for any amount of time and moisture may be present in the circuit, flush the muffler or system as necessary (refer to Par. 13-17). Install a new receiver-dehydrator in system.*

2. Charge the system (refer to Par. 13-29).

13-24 REMOVAL AND INSTALLATION OF CONDENSER RECEIVER-DEHYDRATOR ASSEMBLY

a. Removal

1. Discharge system (refer to Par. 13-15).

2. Disconnect inlet and outlet pipes of condenser receiver dehydrator and tape closed the open ends of refrigerant lines, and also the open ends of the inlet and outlet pipes of the condenser.

3. Remove one bolt securing each cross brace to the upper tie bar and position braces out of way.

4. Remove three screws securing underside of center support and locking mechanism to upper tie bar, one screw securing lower end of center support to lower tie bar, and two nuts securing center support to grille. Then remove center support locking mechanism.

5. Remove screws holding right and left flanges of condenser to radiator support and remove condenser.

b. Installation

1. Install condenser reverse of removal and use new "O" rings during installation. Lubricate "O" rings

prior to installation using NO. 525 viscosity oil.

NOTE: *If refrigerant circuit or condenser has been exposed to the atmosphere and moisture may be present in circuit, the system and/or component must be flushed prior to installation (refer to Par. 13-17).*

2. Charge the refrigerant circuit (refer to Par. 13-29).

13-25 REMOVAL AND INSTALLATION OF RECEIVER - DEHYDRATOR

a. Removal

1. Discharge system (refer to Par. 13-15).

2. Remove necessary parts to gain access to receiver- dehydrator.

3. Disconnect refrigerant lines to both ends of receiver-dehydrator and tape closed open ends of refrigerant lines, and also the open ends of the inlet and outlet pipes of the receiver-dehydrator.

4. Remove two screws securing receiver-dehydrator and clamp to support bracket and lift out receiver-dehydrator.

b. Installation

1. Install receiver-dehydrator reverse of removal and use new "O" rings during installation. Lubricate "O" rings with No. 525 viscosity oil prior to installation.

NOTE: *If the receiver-dehydrator has been exposed to the atmosphere for any amount of time, (more than 5 minutes) the receiver-dehydrator should be replaced, since the life of dessicant is probably expended.*

2. Charge refrigerant circuit (refer to Par. 13-29).

13-26 REMOVAL AND INSTALLATION OF EXPANSION VALVE

a. Removal

1. Discharge system (ref. Par. 13-15) and disconnect expansion valve capillary tube bulb attached to the outlet pipe of the evaporator.

2. Disconnect the equalizer line from the body of valve. Tape closed equalizer line port on POA valve, and also open end of equalizer line.

3. Disconnect inlet and outlet ends of expansion valve from refrigerant lines, and tape closed open ends of refrigerant lines and inlet and outlet ports of expansion valve.

4. Remove outer clamp of bracket securing expansion valve and POA valve to plenum blower and air valve assembly, and remove expansion valve.

b. Installation

1. Install expansion valve reverse of removal, and use new "O" rings during installation. Lubricate "O" rings prior to installation using No. 525 viscosity oil.

NOTE: *If expansion valve or refrigerant lines have been exposed to the atmosphere for any amount of time and moisture may have entered the valve or the system, flush the system and install new receiver- dehydrator or valve as necessary (refer to paragraph 13-17).*

2. Charge system (refer to Par. 13-29).

NOTE: *Due to the possible adjustment difficulties involved if the expansion valve is disassembled, disassembly of the valve is not recommended. The valve may be cleaned by submerging it in a bath of trichlorethylene, alcohol, or similar solvent. Dry by blowing filtered compressed air through the outlet port of the valve. The filter screen at the inlet port may be replaced. Remove screen by threading a 10-32 NF screw into old filter screen. With a washer and a nut on the screw arranged to work as a puller screw, hold the body of the screw and turn*

the nut. Insert the new filter screen into the inlet port and lightly tap screen only enough to seat.

13-27 REMOVAL AND INSTALLATION OF EVAPORATOR

a. Removal

(43-44000 SERIES)

1. Remove right front fender skirt.
2. Discharge refrigerant from system (ref. Par. 13- 15) and disconnect suction line from POA valve and liquid line from expansion valve. See Figure 13-55. Tape closed openings in valve and line.
3. Disconnect resistor connector and remove one screw securing blower motor ground wire to dash.
4. Remove four nuts and six screws securing evaporator-blower assembly to dash. See Figure 13- 123. Remove evaporator-blower assembly.
5. Disconnect oil bleed line from POA valve. Peel back black insulation putty around evaporator outlet pipe and remove capillary tube bulb from evaporator outlet pipe.
6. Disconnect POA valve and expansion valve from evaporator outlet and inlet pipes. Tape closed all connection openings.
7. Remove six screws securing right and left halves of evaporator-blower assembly and remove evaporator.

(45-46-48000 SERIES)

1. Discharge refrigerant from system (refer to Par. 13-15).
2. Disconnect oil bleed line, equalizer line and suction line from POA valve (See Figure 13-57).
3. Peel back black insulating putty from around evaporator assembly outlet pipe and disconnect expansion valve bulb.

4. Disconnect clips from side of evaporator that secure expansion valve lines in place.
5. From underside of car unscrew nut holding expansion valve to evaporator assembly.
6. Disconnect any vacuum hoses or electrical wires attached to clips along topside of evaporator.
7. From under instrument panel, remove three screws securing bottom side of evaporator to dash. (See Figure 13-125).
8. Remove six screws securing evaporator assembly to dash and lift out POA valve and evaporator as an assembly.
9. Tape closed all refrigerant line openings and openings in expansion valve, POA valve, and evaporator assembly.

(49000 SERIES)

1. Remove right front fender and skirt.
2. Discharge refrigerant system refer to Par. 13- 15.
3. Disconnect liquid line from expansion valve and tape openings closed (see Figure 13-59).
4. Disconnect suction line from POA valve and tape openings closed (see Figure 13-59).
5. Disconnect blower motor connector and ground wire.
6. Remove eight screws securing evaporator and blower assembly to dash. See Figure 13-126.
7. Loosen six screws securing air conditioner-heater assembly to dash. See Figure 13-127.
8. Move blower end slightly forward to clear dash flange, then slide evaporator housing outboard enough to clear heater housing lip and remove.

b. Installation

(ALL SERIES)

1. Reverse removal procedure to install, using new "O" rings on line fittings.
2. Evacuate, charge and leak test system.

13-28 REMOVAL AND INSTALLATION OF POA VALVE

a. Removal

NOTE: *When replacing a POA valve, the serviceman should check the interior of the old valve for corrosion or crystalization of salts. This would indicate excessive moisture in the system. If this condition exists, the receiver-dehydrator should be replaced and the system evacuated for one hour.*

1. Discharge system (refer to Par. 13-15).
2. Disconnect evaporator oil bleed line from body of POA valve and tape closed opening on POA valve and also end of oil bleed line. 43-44000 Series see Figure 13-123. 45-46-48000 Series see Figure 13-57. 49000 Series see Figure 13-126.
3. Disconnect equalizer line from the body of the POA valve. Tape closed equalizer line port on body of valve and also end of equalizer line.
4. Disconnect inlet and outlet ends of POA valve from refrigerant lines, and tape closed inlet and outlet ends of valve. Also tape closed both refrigerant lines.
5. Remove screw securing POA valve to bracket and remove POA valve.

b. Installation

1. Install reverse of removal using new "O" rings lubricated with No. 525 viscosity oil.

13-60 HEATER-AIR CONDITIONING SYSTEM

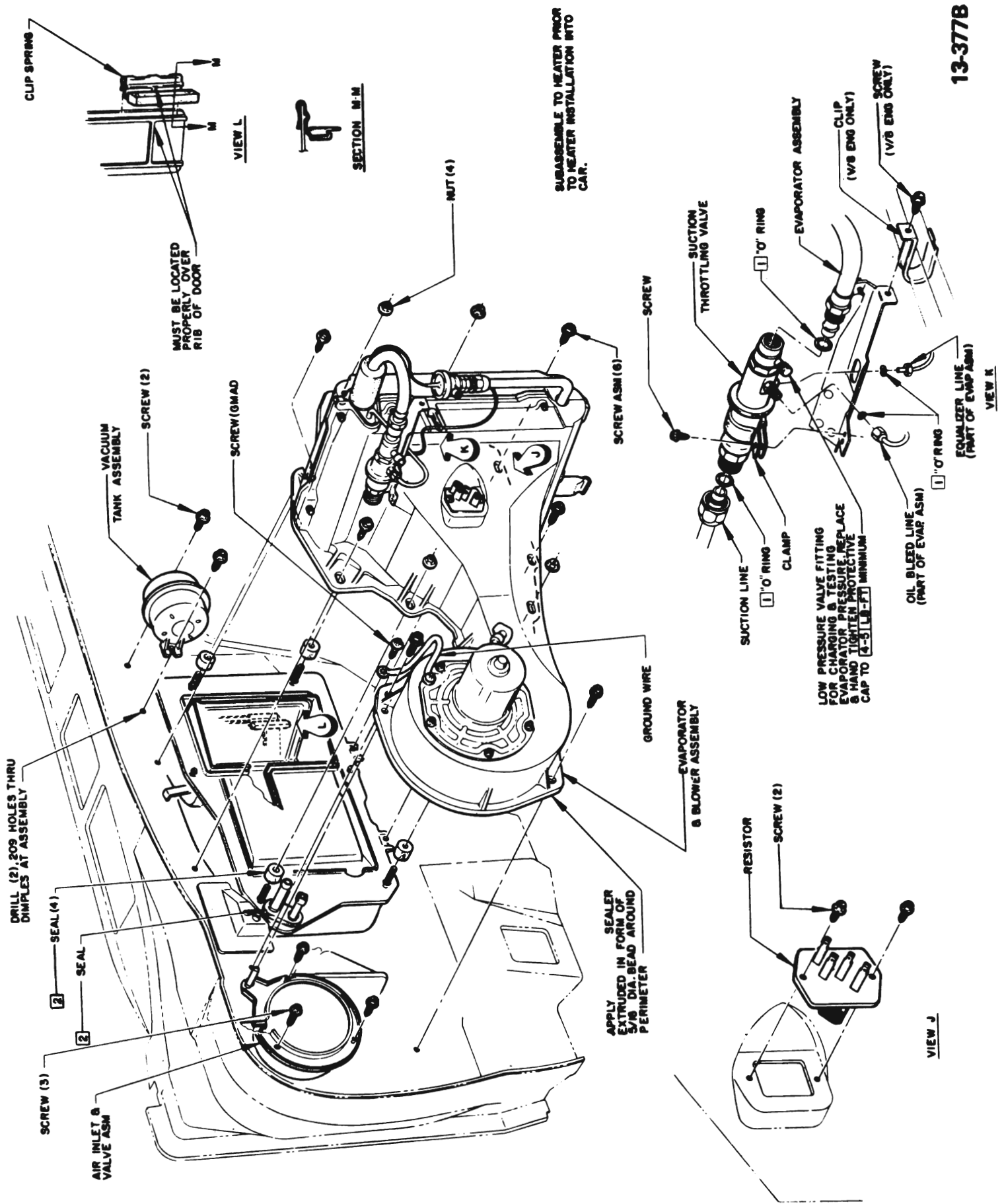

13-377B

SUBASSEMBLY TO HEATER PRIOR TO HEATER INSTALLATION INTO CAR.

MUST BE LOCATED PROPERLY OVER RIB OF DOOR

LOW PRESSURE VALVE FITTING FOR CHARGING & TESTING EVAPORATOR PRESSURE REPLACE & HAND TIGHTEN TO MINIMUM CAP TO (4-5 LB-FI) MINIMUM

APPLY SEALER EXTRUDED IN FORM OF 5/8 DIA. BEAD AROUND PERIMETER

Figure 13-23 Evaporator - Blower Assembly, 43-44000 Series

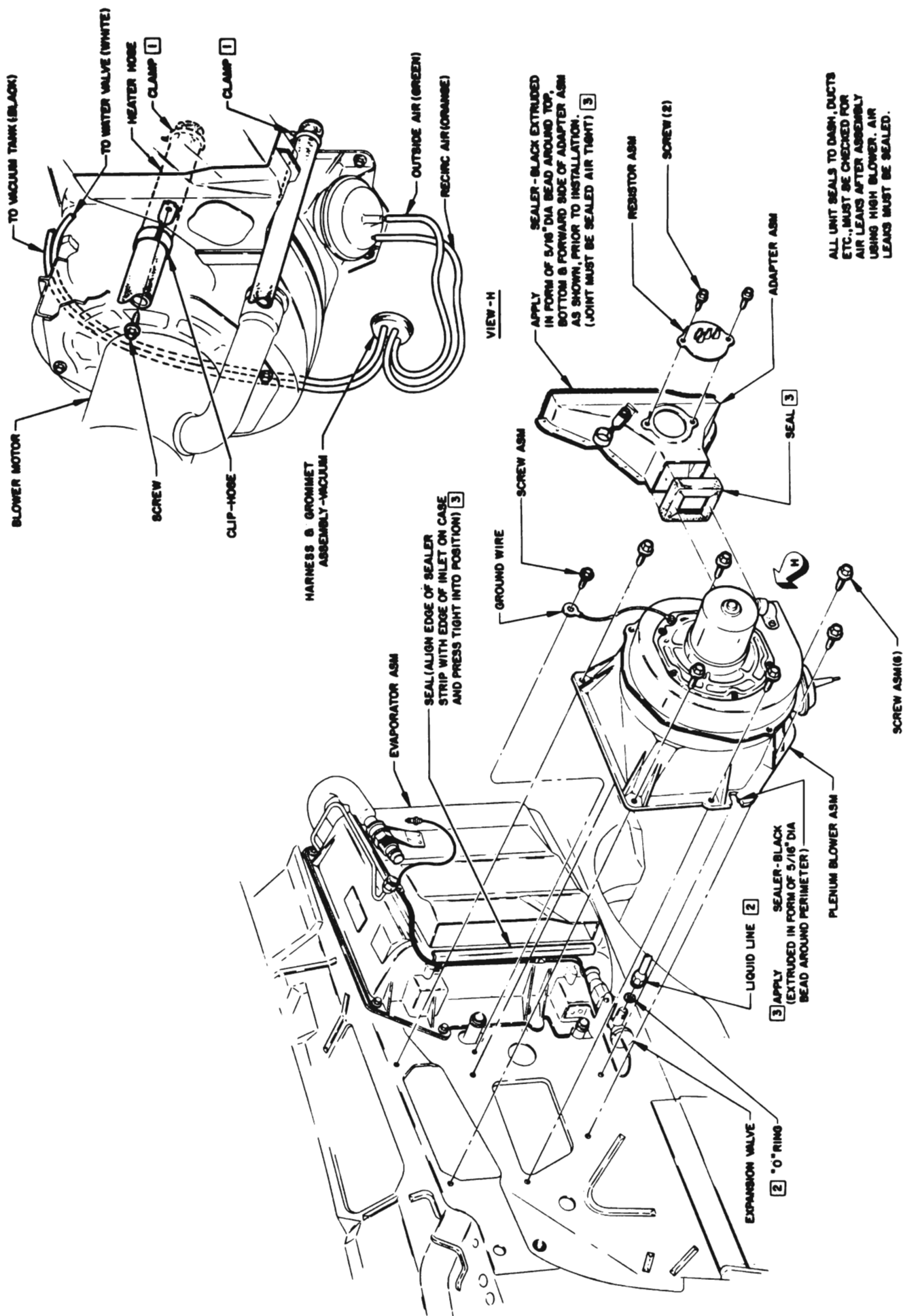

ALL UNIT SEALS TO DASH, DUCTS ETC., MUST BE CHECKED FOR AIR LEAKS AFTER ASSEMBLY USING HIGH BLOWER. AIR LEAKS MUST BE SEALED.

13-379B

Figure 13-124 Plenum Blower Assembly and Adapter, 45-46-48000 Series

13-62 HEATER-AIR CONDITIONING SYSTEM

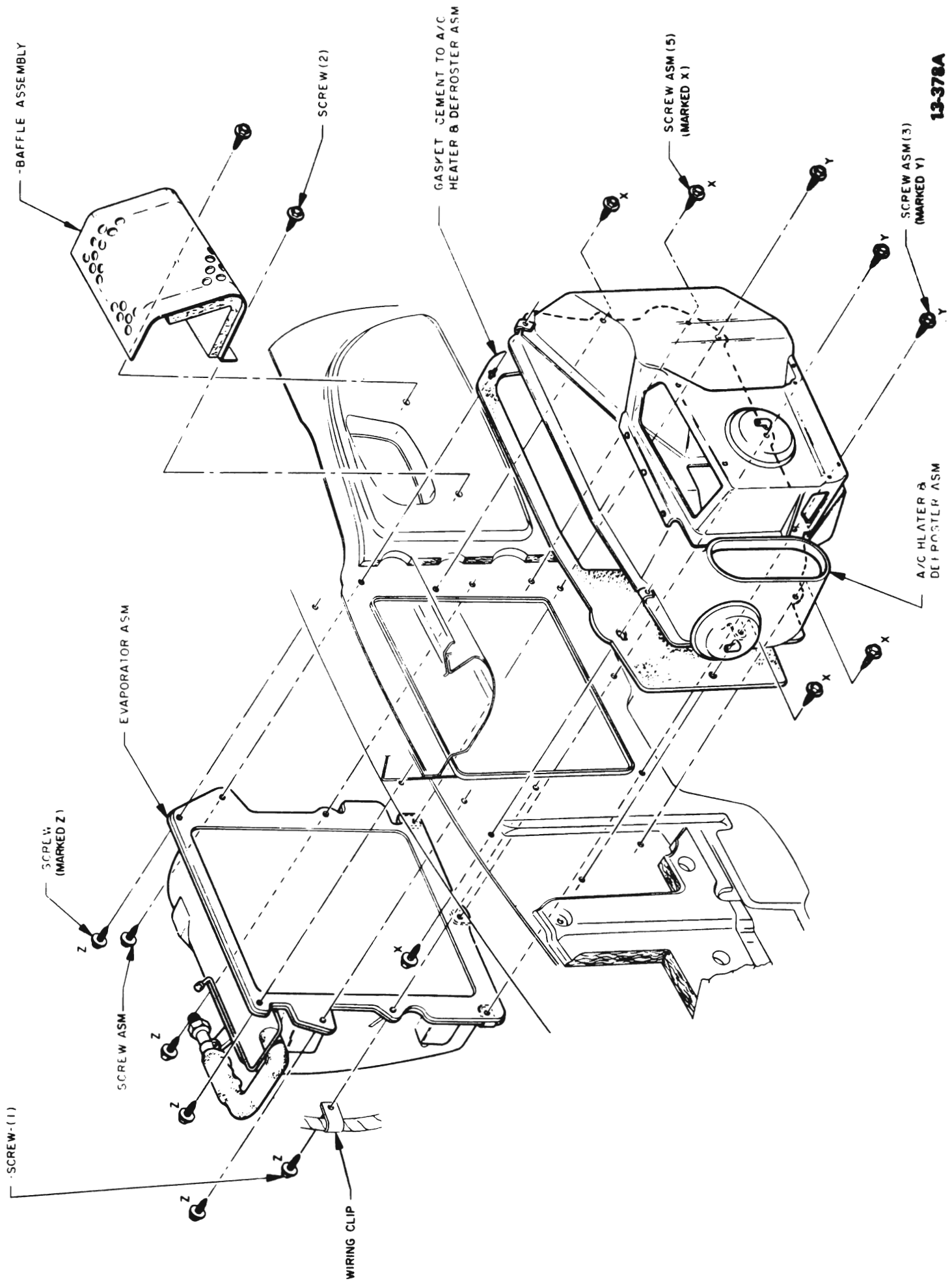

13-378A

Figure 13-125 Air Conditioner-Heater Assembly, and Evaporator Assembly, 45-46-48000 Series

SUCTION THROTTLING VALVE

- (A) THE OPERATION OF THE SUCTION THROTTLING VALVE MUST BE CHECKED DURING FUNCTIONAL TEST.
- (B) THE SUCTION THROTTLING VALVE WILL BE ADJUSTED AT THE SOURCE. IN THE EVENT SUCTION PRESSURES DO NOT FALL WITHIN THE REQUIRED LIMITS, REPLACE VALVE.

THE ASSEMBLY PRECAUTIONS ON AIR CONDITIONING LINES SHOWN ON THESE DRAWINGS ARE MANDATORY & MUST BE FOLLOWED.

EACH COMPLETED AIR CONDITIONING SYSTEM MUST BE LEAK TESTED & GIVEN A FUNCTIONAL TEST AFTER CHARGING

- 1 LOW PRESSURE VALVE FITTING FOR CHARGING & TESTING EVAPORATOR PRESSURE. REPLACE & HAND TIGHTEN PROTECTIVE CAP (4-3 LBS FT)

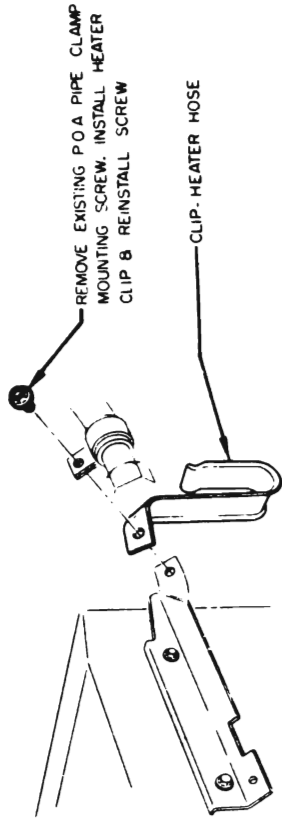
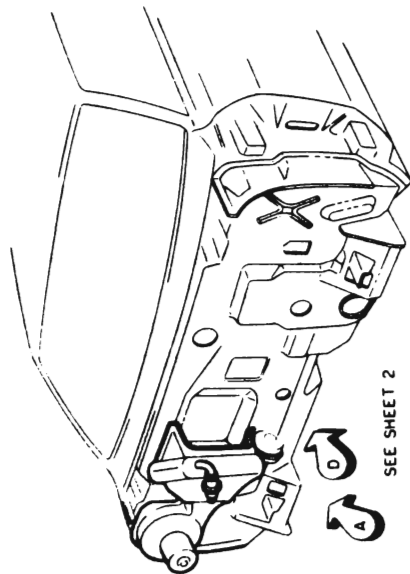

VIEW "B"

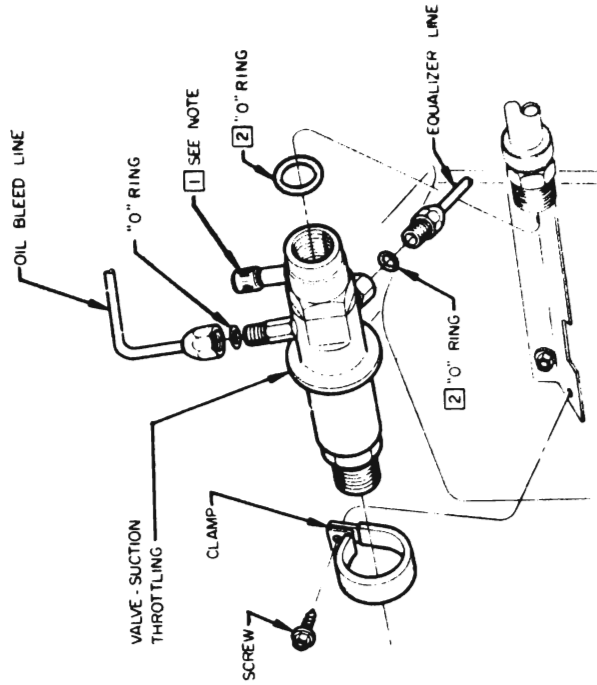

VIEW "C"

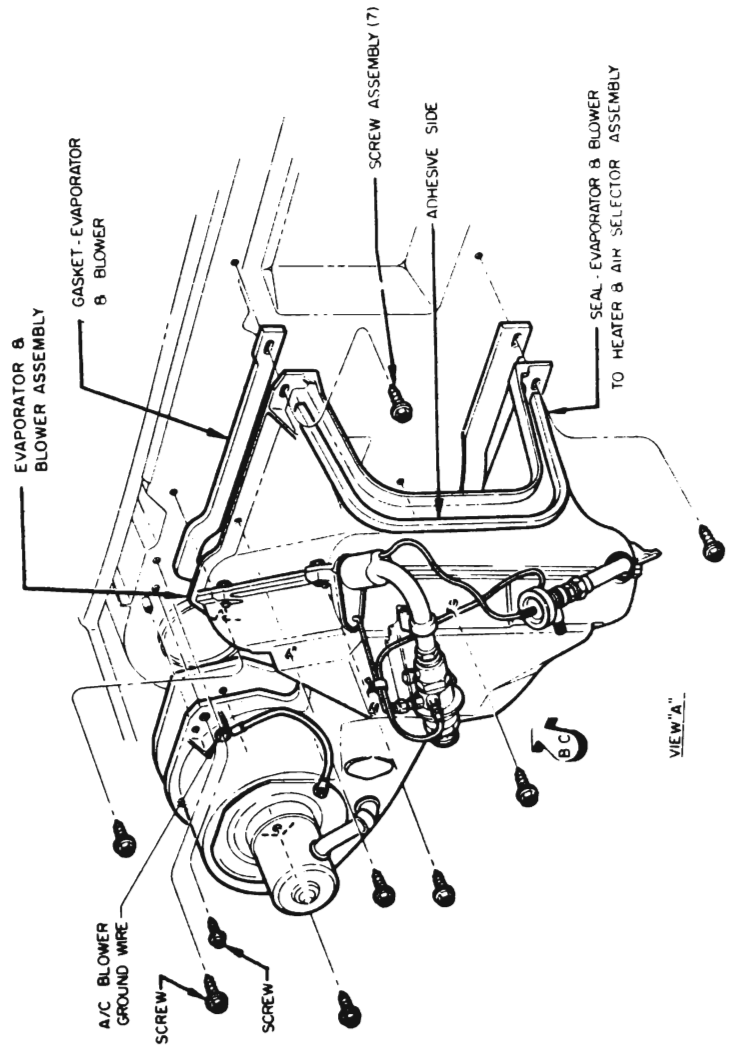

VIEW "A"

13-380A

Figure 13-126 Evaporator-Blower Assembly, 49000 Series

NOTE: *If POA valve and refrigerant line openings have been exposed excessively to the atmosphere it is recommended that system be flushed out to remove any traces of moisture (refer to Par. 13-17).*

2. Charge system (refer to Par. 13-29).

13-29 CHARGING SYSTEM

Charging of air conditioner system consists essentially of evacuating the system, checking for leaks, primary charging, final evacuation and final charging of system. Proceed as follows using either the cylinder-pail method or the service station method.

a. Cylinder-Pail Method of Charging and Evacuating System

(EVACUATING SYSTEM)

1. Remove protective cap from Schrader valve located on POA suction throttling valve, and Schrader valve located on discharge port of compressor.

2. Interconnect vacuum pump (J-5428), manifold and gage set (J-5225-01), gage hook-up set (J-5462), gage adapters (J-5420), five gage charging lines (J-5418) and Refrigerant-12 cylinder with air conditioning system with air conditioning system (see Figure 13-128). Be sure all valves are closed.

3. Start vacuum pump and open both high and low pressure valves on manifold and gage set. Slowly open shut-off valve of gage hook-up set.

NOTE: *If shut off valve is opened too quickly, oil may be forced out of vacuum pump.*

4. Operate pump until at least 28 inches of vacuum (at sea level) registers on the low pressure gage of the manifold and gage set and operate vacuum pump for 10 minutes at or below this vacuum level.

(CHECKING FOR LEAKS)

5. Close shut-off valve, stop vacuum pump, and observe that vacuum does not drop more than 2 inches in 5 minutes.

NOTE: *Allowance should be made for elevation when obtaining a vacuum. Compute vacuum level to be obtained by subtracting 1 inch of vacuum for each 1000 feet of elevation above sea level.*

6. If 28 inches of vacuum (sea level) cannot be obtained, or if vacuum drop with vacuum pump off is more than 2 inches in 5 minutes, then open cylinder valve to charge system at ambient cylinder pressure. Close cylinder valve, test the system for leaks using appropriate equipment and correct any leaks found. Repeat preceding Step 5.

(PRIMARY CHARGING)

7. Primary charge system at ambient cylinder pressure by opening cylinder valve allowing refrigerant vapor to flow into system.

(FINAL EVACUATION)

8. Final-evacuate system by closing cylinder valve, starting vacuum pump, and slowly opening shut-off valve. Maintain 28 inches of vacuum for 10 minutes and then close shut-off valve and stop vacuum pump.

9. Close high pressure valve on manifold and gage set.

(FINAL CHARGING)

10. Heat a pail of water to 125°F and place it on a scale. Place refrigerant cylinder in pail and record total weight.

CAUTION: *Never heat cylinder above 125°F as dangerous hydrostatic pressures result in cylinder. When there is danger of cylinder overheating, a suitable pressure relief valve should be connected into the circuit. It may be necessary to reheat the water during charging operation to maintain proper temperature.*

11. Open cylinder valve, idle engine and operate compressor until scale has decreased by amount required to charge the system. This indicates that the required amount of refrigerant has been charged into the system.

12. Close valve on cylinder, low pressure valve, and remove cylinder from pail of water.

13. Perform functional test (refer to Par. 13-35).

14. Remove gage charging lines from system and replace protective caps over Schrader valve fittings and tighten caps securely.

b. Charging Station Method of Charging

(INITIAL HOOK-UP OF CHARGING STATION)

1. Close all valves on charging station J-8393.

2. Connect high pressure charging line to Schrader valve on compressor using adapter J-5420 (see Figure 13-128).

(FILLING CHARGING STATION)

3. Open refrigerant cylinder valve, charging cylinder fill valve and charging cylinder bleed valve, allow charging cylinder to fill to required level, then shut off refrigerant cylinder valve and charging cylinder bleed valve.

NOTE: *When filling the cylinder, it will be necessary to close the bleed valve periodically to allow to allow bubbling to stop so that refrigerant level in charging cylinder can be accurately read.*

(PURGING AND EVACUATING SYSTEM)

4. Open low pressure valve and high pressure valve on charging station.

NOTE: *If there is any refrigerant charge in the system, the controls should be opened only far enough to*

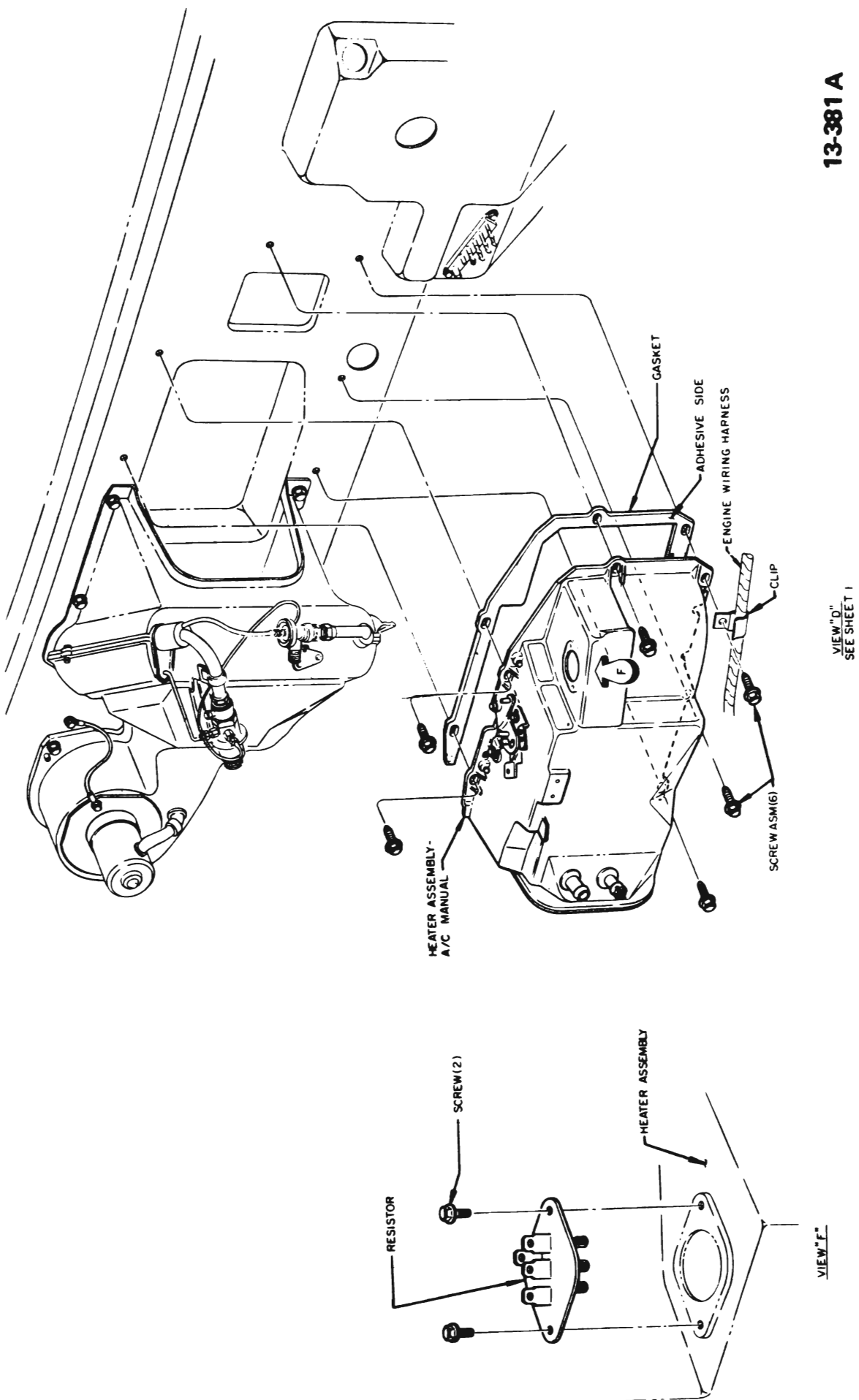
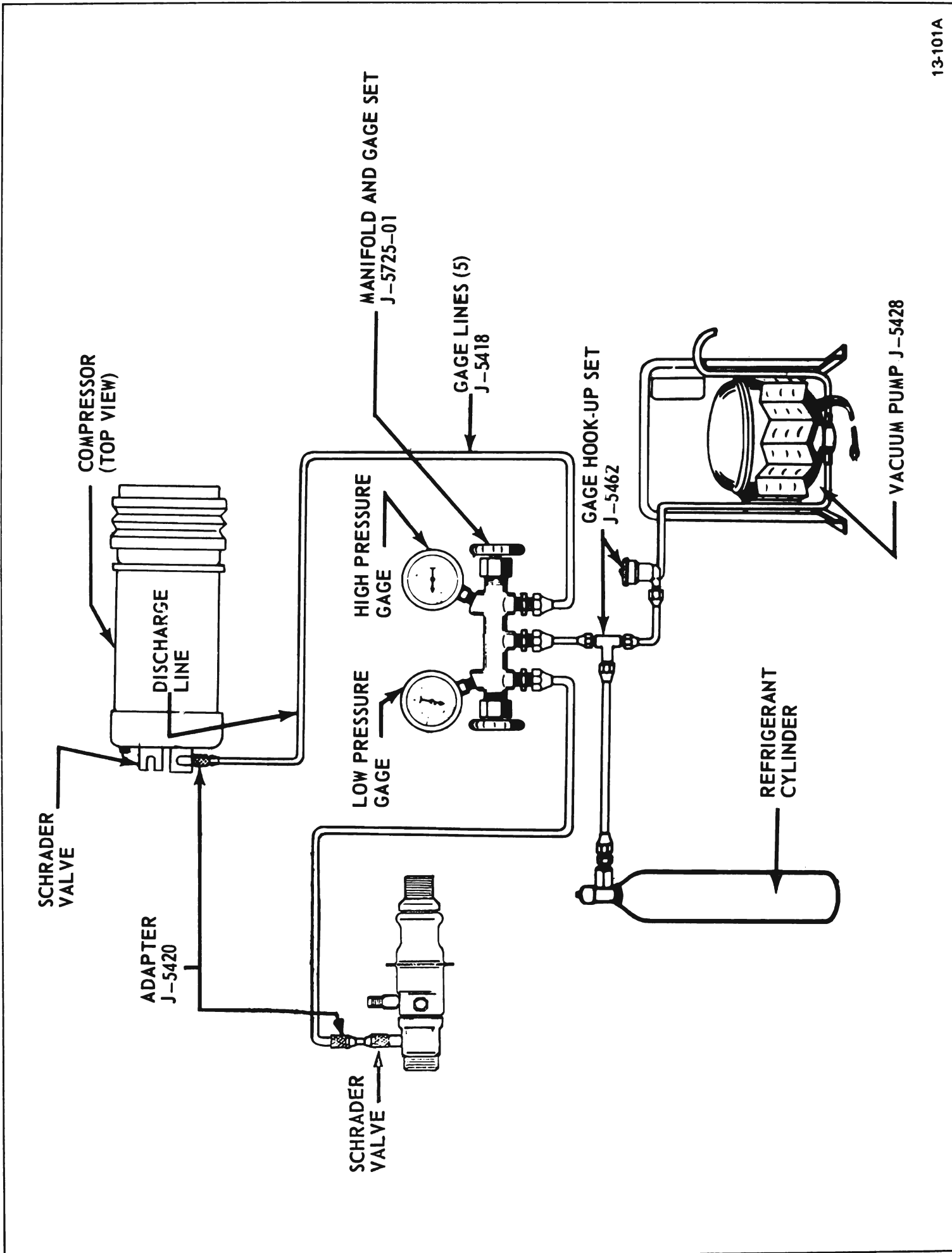

Figure 13-127 Air Conditioner-Heater Assembly, 49000 Series



13-101A

Figure 13-128 Charging Air Conditioner System

perform refrigerant to slowly discharge. If the system discharges too fast, oil will escape along with the refrigerant.

5. Connect the low pressure charging line (blue) to the Schrader valve on the POA valve, open vacuum valve, and turn vacuum pump switch on. Low pressure gage reading should decrease to 26 to 28 inches of vacuum. Allow pump to operate for 10 minutes after this gage reading is obtained, then close shut-off valve and stop vacuum pump.

NOTE: The specified vacuum of 26 to 28 inches is obtainable only in areas situated at or near sea level. For each 1000 feet above sea level where this procedure is performed, the specification of 26 to 28 inches should be lowered by one inch.

6. If 26 to 28 inches of vacuum (corrected to the area in which this procedure is performed) cannot be obtained, then close vacuum valve, open refrigerant valve and allow about one pound of refrigerant to enter system. Close refrigerant valve and using a leak detector, locate the source of the leak and correct condition.

7. Repeat Steps 5 and 6 until satisfactory results are obtained.

(FLUSHING SYSTEM)

8. Close vacuum valve and open refrigerant valve until 1/2 pound of refrigerant enters system, then close refrigerant valve.

9. Open vacuum valve, turn on vacuum pump switch and operate pump for about 10 minutes. Then close vacuum valve, and shut off vacuum pump switch.

(CHARGING SYSTEM)

10. Close low pressure valve, open refrigerant valve and allow full charge of refrigerant to enter system.

11. If full charge of refrigerant will not enter system, then start engine

and run it at fast idle with compressor operating. Intermittently open and close low pressure valve until full charge of refrigerant enters system.

(SERVICING AIR DISTRIBUTION COMPONENTS)

13-30 REMOVAL AND INSTALLATION OF BLOWER MOTOR

a. Removal

(43-44000 SERIES)

1. Remove right front fender skirt.

NOTE: Refer to Group 110, paragraph 110-7.

2. Remove one screw securing ground wire to motor and disconnect electrical connector from blower motor. See Figure 13-123.

3. Remove five screws securing blower motor to evaporator housing and remove blower motor.

(45-46-48000 SERIES)

1. Remove one screw securing ground wire to motor and disconnect electrical connector from blower motor. See Figure 13-124.

2. Remove five screws securing blower motor to plenum blower assembly and remove blower motor.

(49000 SERIES)

1. Remove right front fender skirt.

NOTE: Refer to Group 110, paragraph 110-24.

2. Remove one screw securing ground wire to motor and disconnect electrical connector from blower motor. See Figure 13-126.

3. Remove five screws securing blower motor to evaporator housing and remove blower motor.

b. Installation

(ALL SERIES)

Install reverse of removal procedures.

13-31 REMOVAL AND INSTALLATION OF AIR CONDITIONER-HEATER ASSEMBLY, HEATER CORE, OR AIR DISTRIBUTOR DUCTS

a. Removal

(43-44000 SERIES)

1. Drain radiator and disconnect heater hoses from inlet and outlet pipes of heater core. Insert cork or rubber plugs in heater core inlet and outlet pipes.

2. Remove instrument panel cover with right side A/C outlet and hose attached. See Figures 13-131 and 13-132.

3. Remove center A/C duct, left A/C outlet duct, A/C distributor duct and defroster assembly. See Figure 13-133.

4. Disconnect defroster and temperature control wires. See Figure 13-134.

5. Remove four nuts and two screws securing air condition heater assembly to dash and remove assembly. See Figure 13-134.

(45-46-48000 SERIES)

1. Drain radiator and disconnect heater hoses from inlet and outlet pipes of heater core. Insert cork or rubber plugs in heater core inlet and outlet pipes.

2. Remove instrument panel cover with center A/C outlet and right A/C outlet and hose attached. See Figures 13-135 and 13-136.

3. Remove center A/C duct, A/C distributor duct and defroster outlet manifold assembly. See Figure 13-137.

13-68 HEATER-AIR CONDITIONING SYSTEM

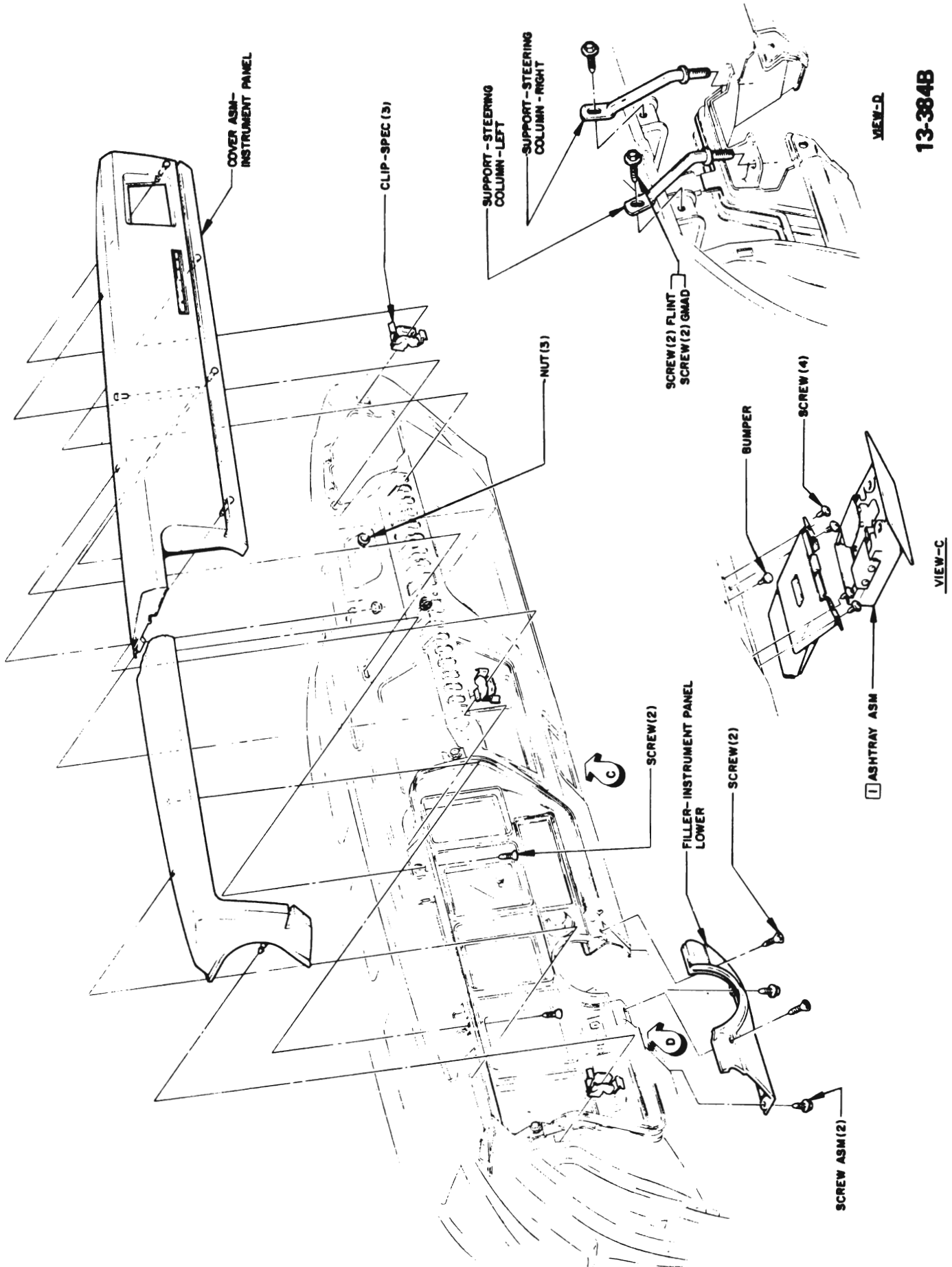
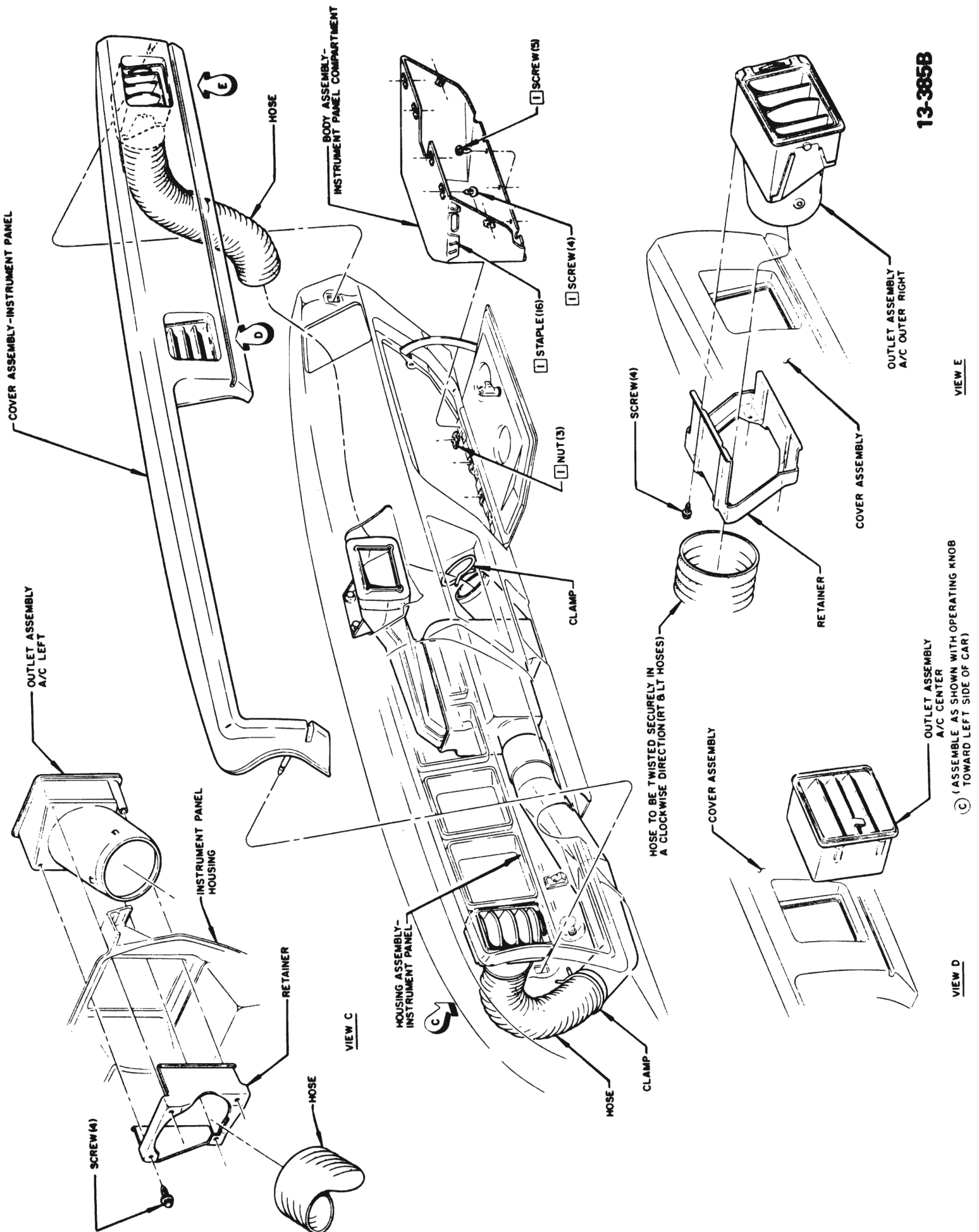

Figure 13-13I Instrument Panel Cover Installation, 43-44000 Series



13-385B

Figure 13-132 A/C Outlets and Air Hoses, 43-44000 Series

13-70 HEATER-AIR CONDITIONING SYSTEM

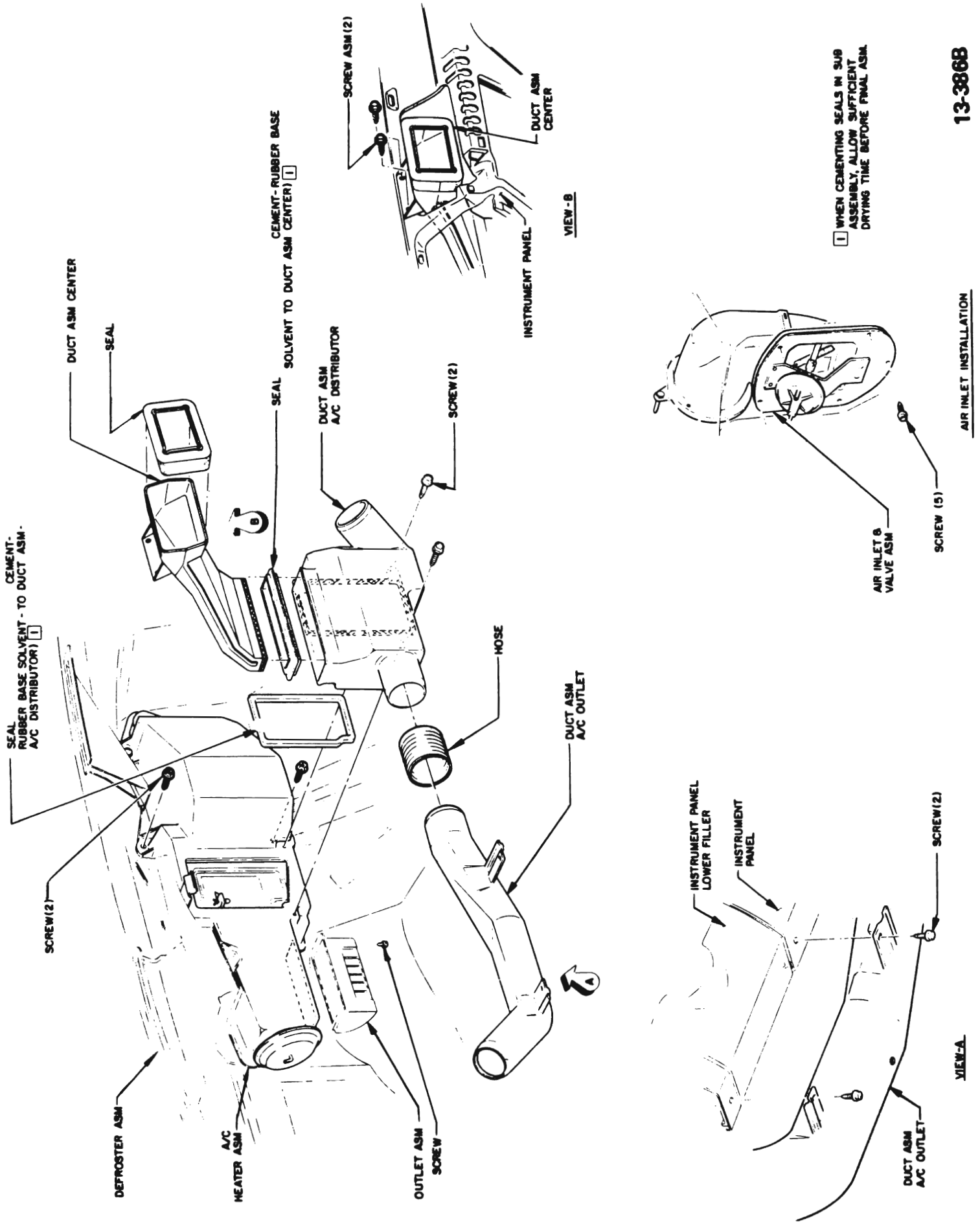

13-386B

Figure 13-133 Defroster Assembly and A/C Ducts, 43-44000 Series

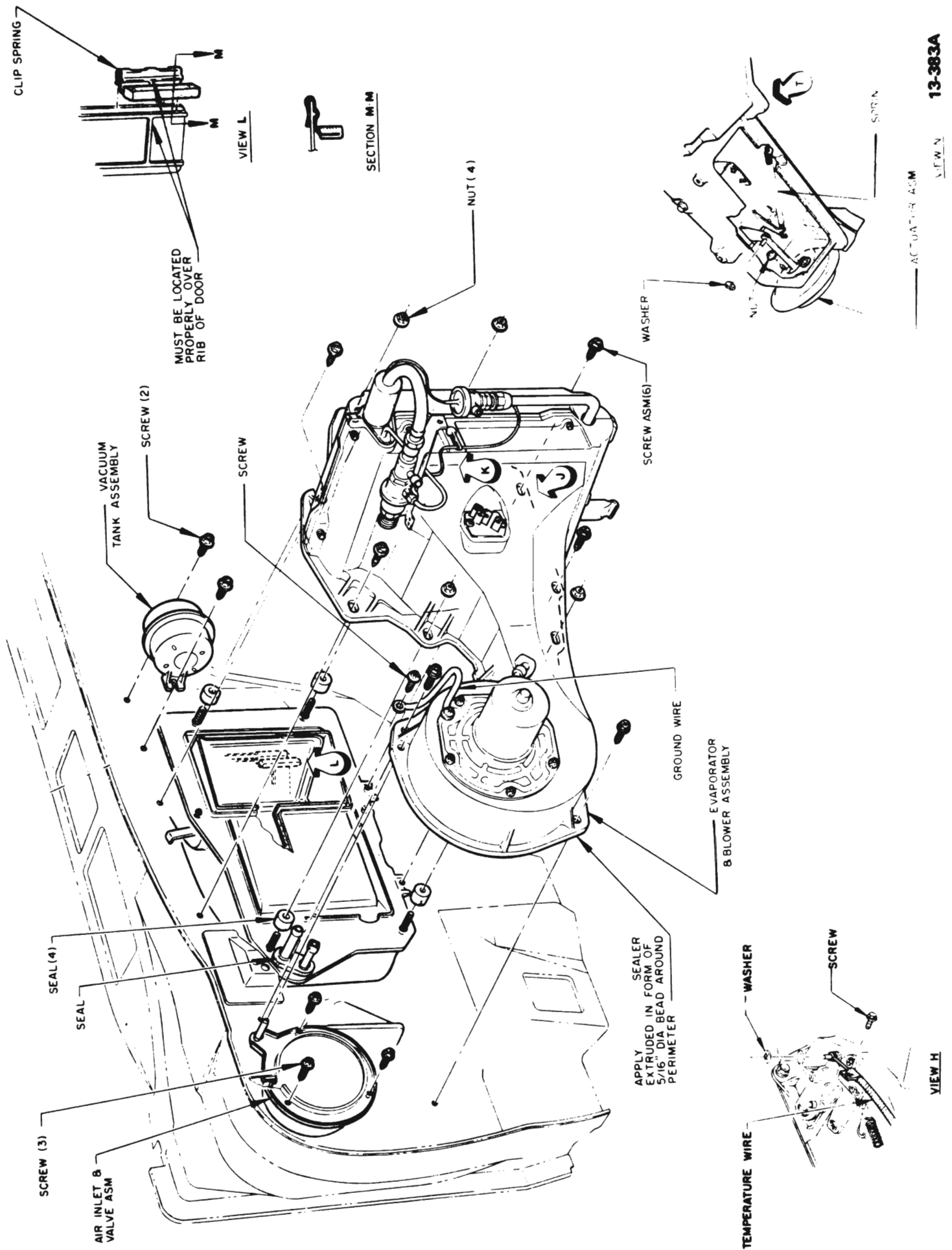
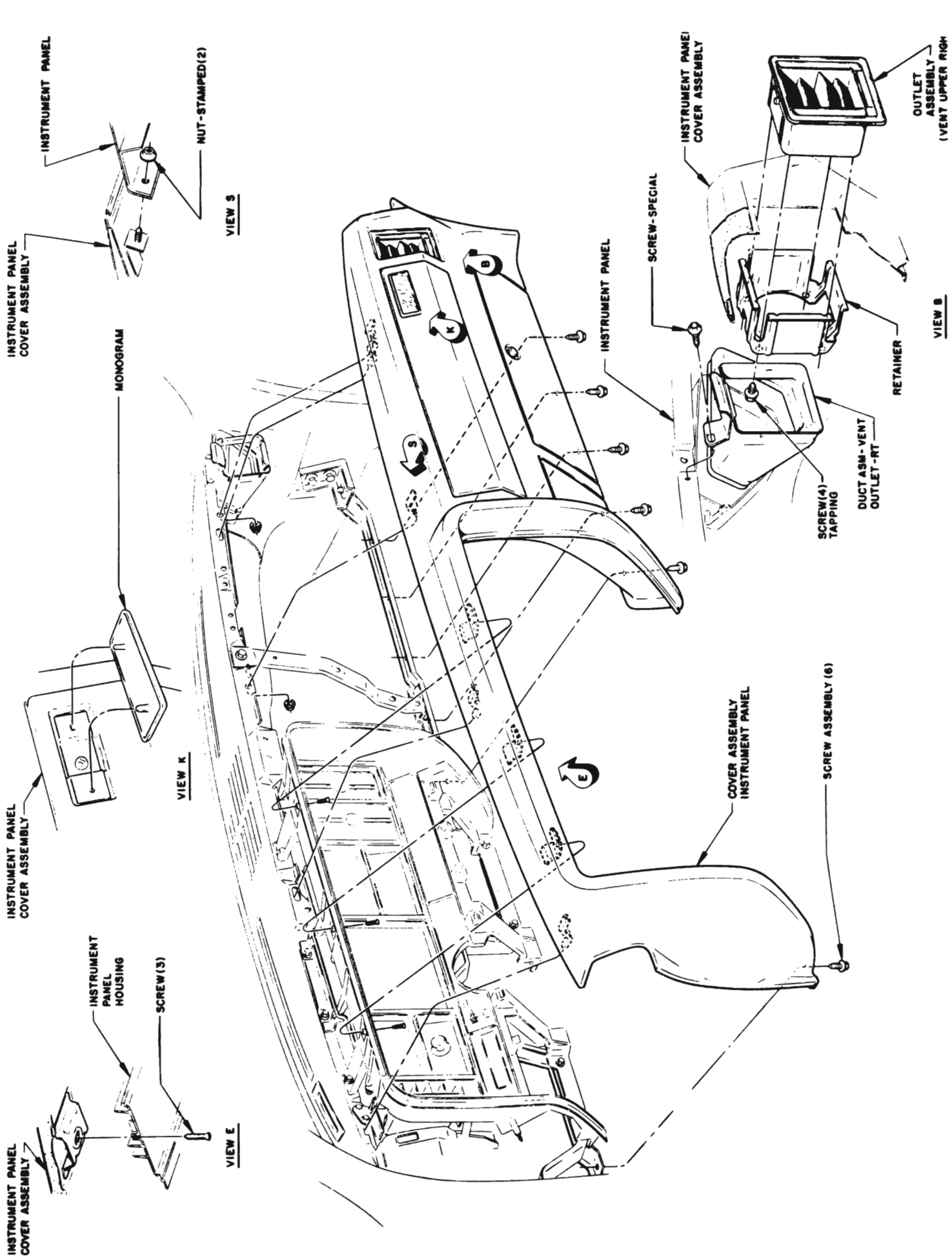

Figure 13-134 Air Conditioner Heater Assembly, 43-44000 Series

13-72 HEATER-AIR CONDITIONING SYSTEM



13-387B

Figure 13-135 Instrument Panel Cover Installation, 45-46-48000 Series

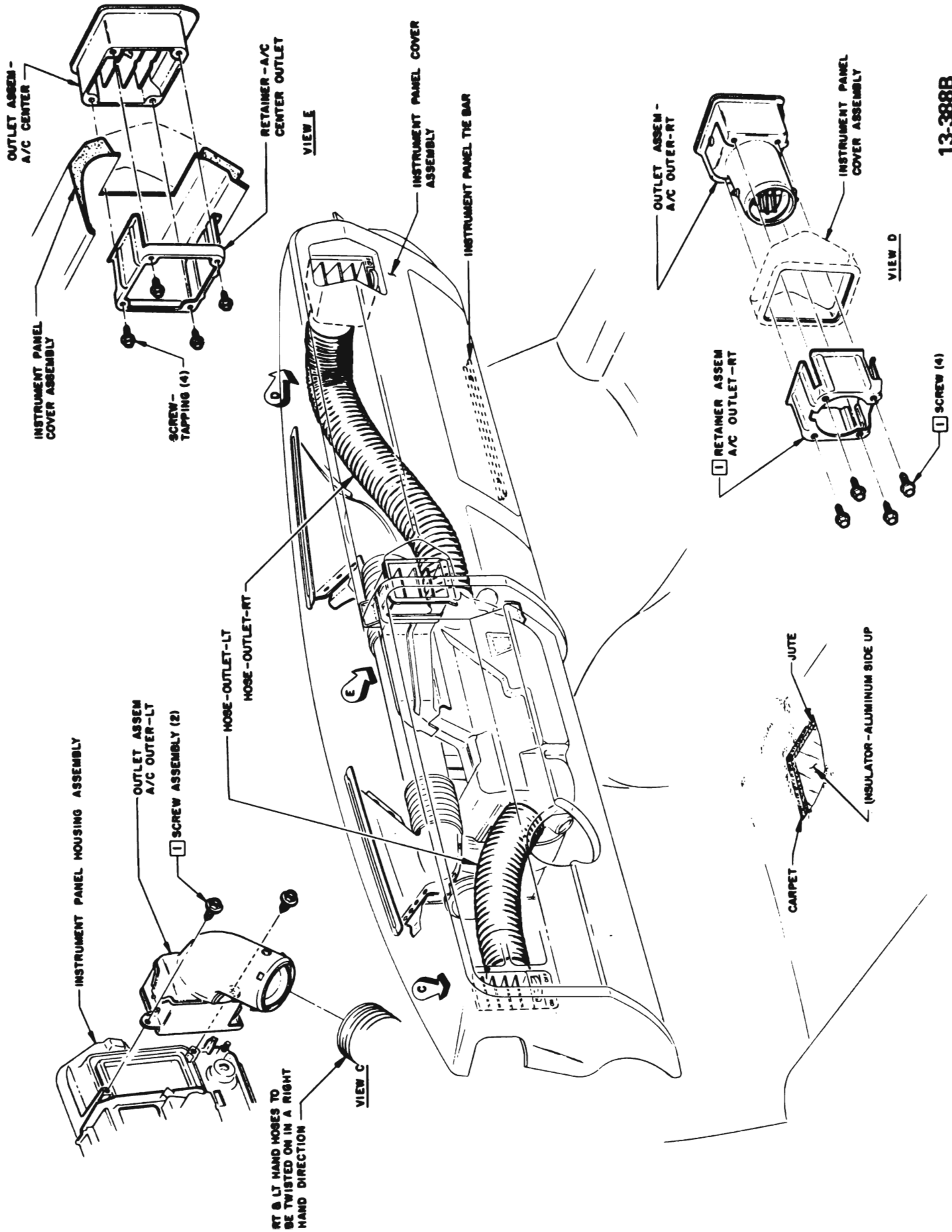

Figure 13-136 A/C Outlets and Air Hoses, 45-46-48000 Series

13-74 HEATER-AIR CONDITIONING SYSTEM

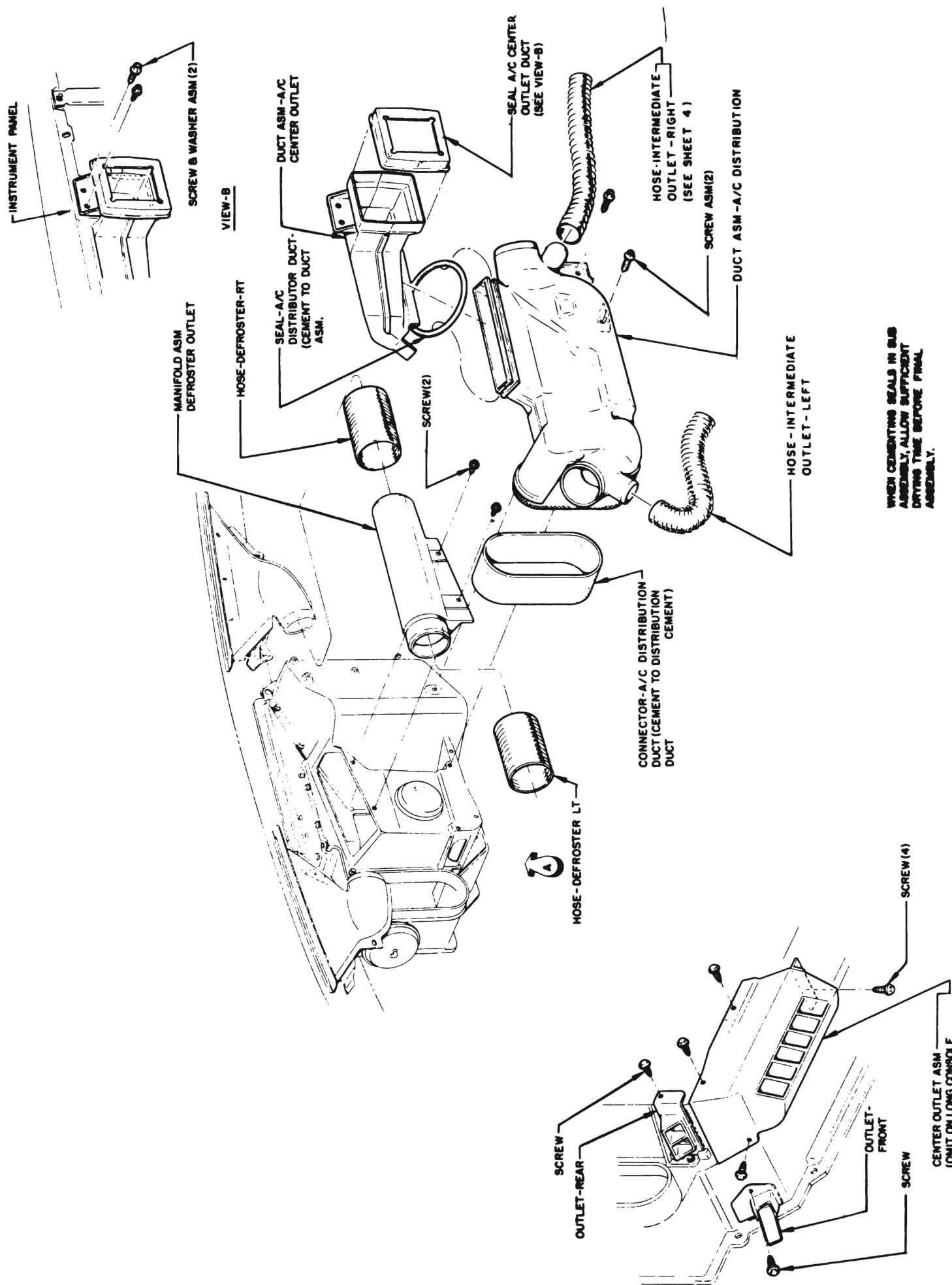

Figure 13-137 Defroster Manifold and A/C Ducts, 45-46-48000 Series

4. Disconnect defroster and temperature control wires and pink hose from mode door diaphragm. See Figure 13-138.

5. Remove seven screws from inside (under instrument panel) and two screws from engine compartment side of dash that secure air conditioner heater assembly to dash and remove assembly. See Figure 13-138.

(49000 SERIES)

1. Drain radiator and disconnect heater hoses from inlet and outlet pipes of heater core.

2. Disconnect temperature door control cable and blower resistor electrical connector. See Figure 13-127.

3. Remove six screws securing air conditioner heater assembly to dash and remove assembly.

4. Air distributor duct removal is shown in Figures 13-139 and 13-140.

b. Installation

(ALL SERIES)

Install reverse of removal procedures.

**13-32 REMOVAL AND
INSTALLATION OF AIR
CONDITIONER CONTROL
ASSEMBLY**

a. Removal

(43-44000 SERIES)

1. Remove left A/C outlet duct.

2. Disconnect light sockets, electrical and vacuum connections.

3. Loosen self-contained nuts on back of control assembly.

4. Move control assembly back out of instrument panel and remove Bowden cable. Remove control assembly.

(45-46-48000 SERIES)

1. Disconnect light sockets, electrical and vacuum connections.

2. Loosen self-contained nuts on back of control assembly.

3. Move control assembly back out of instrument panel and remove Bowden cable. Remove control assembly

(49000 SERIES)

1. Remove ash tray assembly.

2. Remove radio.

3. Loosen self-contained nuts on back of control assembly.

4. Move control assembly back and remove light sockets, electrical and vacuum connections, and Bowden cable.

5. Remove control assembly through ash tray opening.

b. Installation

(ALL SERIES)

1. Install control assembly reverse of removal procedure.

2. Adjust as necessary.

DIVISION IV

TROUBLE DIAGNOSIS

13-33 GENERAL INFORMATION

The following is a brief description of the type of symptom each refrigerant component will evidence if a malfunction occurs:

a. Compressor

Compressor malfunction will appear in one of four ways: noise, seizure, leakage, or low discharge pressure.

NOTE: *Resonant compressor noises are not cause for alarm; however,*

irregular noise or rattles may indicate broken parts or excessive clearances due to wear. To check seizure, de-energize the magnetic clutch and check to see if drive plate can be rotated. If rotation is impossible, compressor is seized. To check for a leak, refer to Par. 13-22 sub-paragraph 'h'. Low discharge pressure may be due to a faulty internal seal of the compressor, or a restriction in the compressor.

NOTE: *Low discharge pressure may also be due to an insufficient refrigerant charge or a restriction elsewhere in the system. These possibilities should be checked prior to servicing the compressor. If the compressor is inoperative; however, is not seized, check to see if current is being supplied to the magnetic clutch coil terminals.*

b. Condenser

A condenser may malfunction in two ways: it may leak, or it may be restricted. A condenser restriction will result in excessive compressor discharge pressure. If a partial restriction is present, sometimes ice or frost will form immediately after the restriction as the refrigerant expands after passing through the restriction. If air flow through the condenser or radiator is blocked, high discharge pressures will result. During normal condenser operation, the outlet pipe will be slightly cooler than the inlet pipe.

c. Receiver-Dehydrator

A receiver-dehydrator may fail due to a restriction inside body of unit. A restriction at the inlet to the receiver-dehydrator will cause high head pressures. Outlet tube restrictions will be indicated by low head pressures and little or no cooling. An excessively cold receiver-dehydrator outlet may be indicative of a restriction.

d. Expansion Valve

Expansion valve failures usually will

be indicated by low suction and discharge pressures, and insufficient evaporator cooling. The failure is generally due to malfunction of the power element and subsequent closing of the valve. A less common cause of the above symptom is a clogged inlet screen.

e. Evaporator

When the evaporator malfunctions, the trouble will show up as inadequate supply of cool air. A partially plugged core due to dirt, a cracked case, or a leaking seal will generally be the cause.

f. POA Valve

If the POA valve is defective, it may cause evaporator pressure (hence air temperature) to be either too high or too low depending on the type of failure. No adjustment is possible on POA valves. If it is determined that a POA valve has failed it should be replaced. See Par. 13-35.

g. Refrigerant Line Restrictions

Restrictions in the refrigerant lines will be indicated as follows:

1. Suction Line - A restricted suction line will cause low suction pressure at the compressor, low discharge pressure and little or no cooling.
2. Discharge Line - A restriction in the discharge line generally will cause the pressure relief valve to open.
3. Liquid Line - A liquid line restriction will be evidenced by low discharge and suction pressure, and insufficient cooling.

h. Use of Receiver-Dehydrator Sight Glass for Diagnosis

At temperatures higher than 70°F, the sight glass may indicate whether the refrigerant charge is sufficient. A shortage of liquid refrigerant is indicated after about five minutes of compressor operation by the appearance of slow-moving bubbles (vapor)

or a broken column of refrigerant under the glass. Continuous bubbles may appear in a properly charged system on a cool day. This is a normal situation. If the sight glass is generally clear and performance is satisfactory, occasional bubbles do not indicate refrigerant shortage.

If the sight glass consistently shows foaming or a broken liquid column, it should be observed after partially blocking the air to the condenser. If under this condition the sight glass clears and the performance is otherwise satisfactory, the charge shall be considered adequate.

In all instances where the indications of refrigerant shortage continues, additional refrigerant should be added in 1/4 lb. increments until the sight glass is clear. An additional charge of 1/2 lb. should be added as a reserve. In no case should the system be overcharged.

13-34 LEAK TESTING SYSTEM

The following two methods are recommended when attempting to locate refrigerant leaks in the system. Loss of refrigerant is always indicative of a leak since refrigerant is not consumed and does not wear out.

1. Open Flame Method - This method utilizes a gas operated torch type leak detector (J-6084). Use of this method is recommended when checking for leaks in confined areas. To perform test, light torch and adjust to obtain a pale blue flame, approximately 1. Suction Line - A restricted suction line will cause low suction pressure at the compressor, low l. Suction Line - A restricted suction line will cause low suction pressure at the compressor, low discharge pressure and little or no cooling.

2. Discharge Line - A restriction in the discharge line generally will cause the pressure relief valve to open.

3. Liquid Line - A liquid line

restriction will be evidenced by low discharge and suction pressure, and 1. Suction Line - A restricted suction line will cause low suction pressure at the compressor, low discharge pressure and little or no cooling.

2. Discharge Line - A restriction in the discharge line generally will cause the pressure relief valve to open.

3. Liquid Line - A liquid line restriction will be evidenced by low discharge and suction pressure, and insufficient cooling.

h. Use of Receiver-Dehydrator Sight Glass for Diagnosis

At temperatures higher than 70°F, the sight glass may indicate whether the refrigerant charge is sufficient. A shortage of liquid refrigerant is indicated after about five minutes of compressor operation by the appearance of slow-moving bubbles (vapor) or a broken column of refrigerant under the glass. Continuous bubbles may appear in a properly charged system on a cool day. This is a normal situation. If the sight glass is generally clear and performance is satisfactory, occasional bubbles do not indicate refrigerant shortage.

If the sight glass consistently shows foaming or a broken liquid column, it should be observed after partially blocking the air to the condenser. If under this condition the sight glass clears and the performance is otherwise satisfactory, the charge shall be considered adequate.

In all instances where the indications of refrigerant shortage continues, additional refrigerant should be added in 1/4 lb. increments until the sight glass is clear. An additional charge of 1/2 lb. should be added as a reserve. In no case should the system be overcharged.

13-34 LEAK TESTING SYSTEM

The following two methods are recommended when attempting to

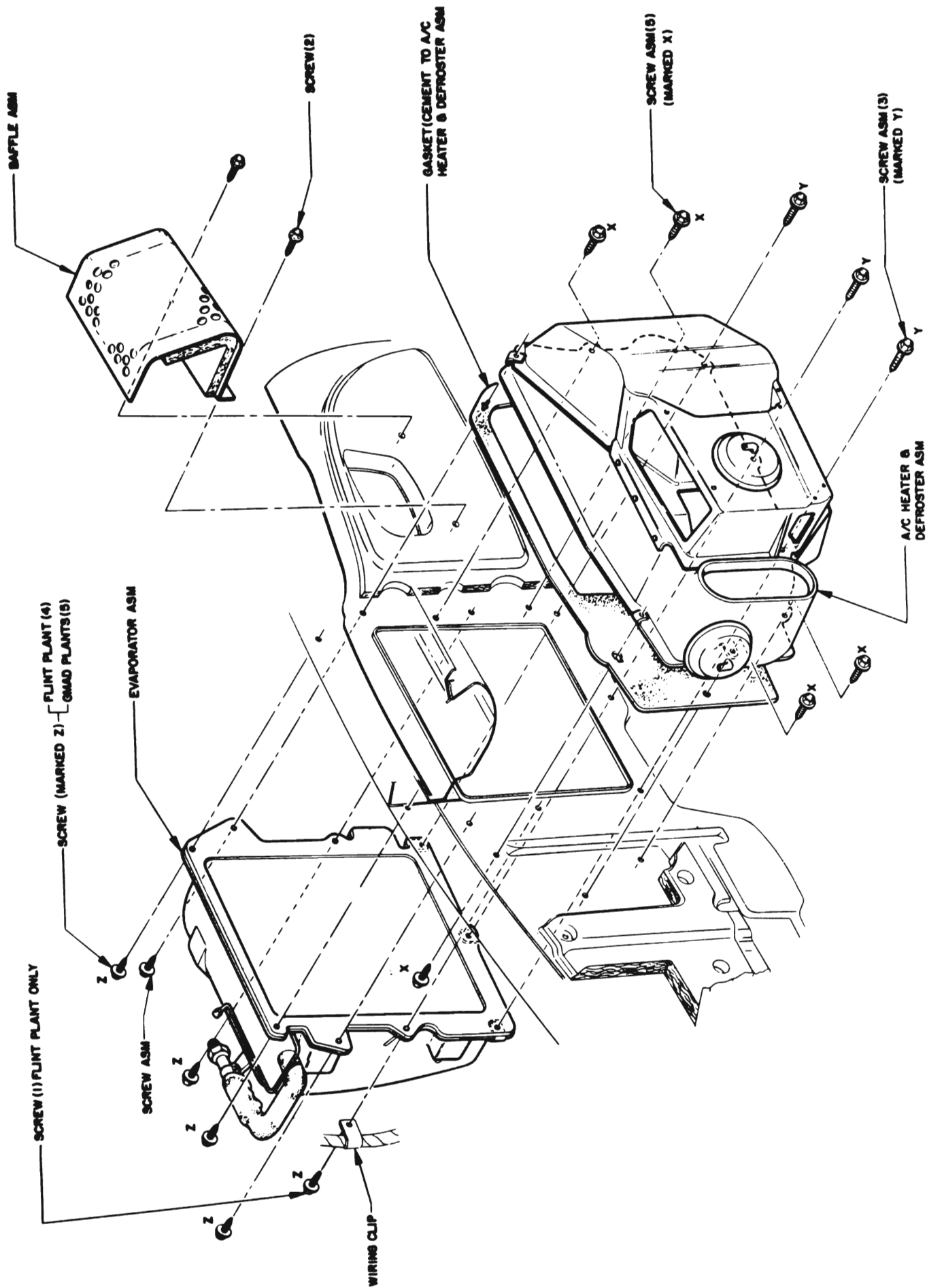

13-390B

Figure 13-138 Air Conditioner Heater Assembly, 45-46-48000 Series

13-78 HEATER-AIR CONDITIONING SYSTEM

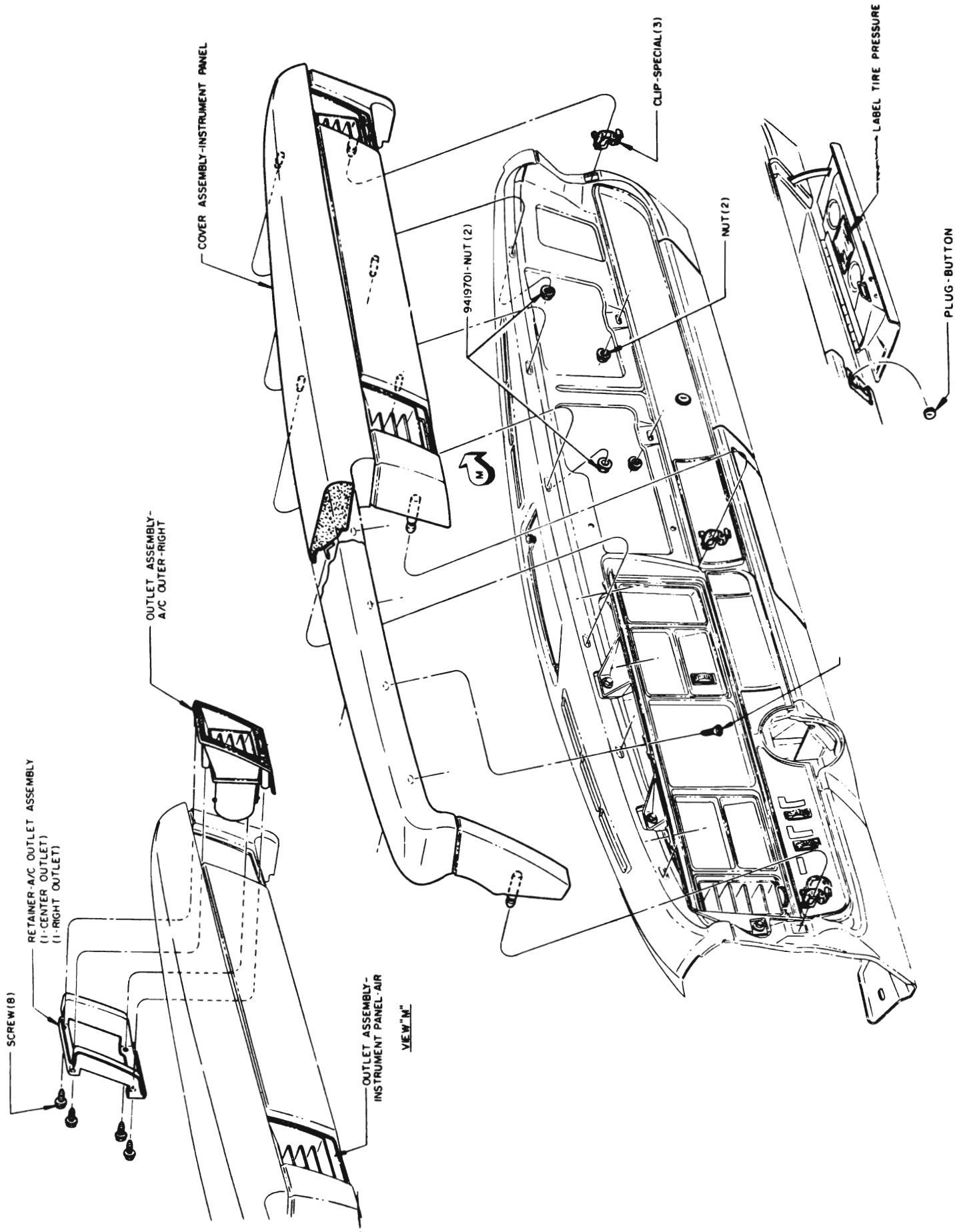

12-46B

Figure 13-139 Instrument Panel Cover Installation, 49000 Series

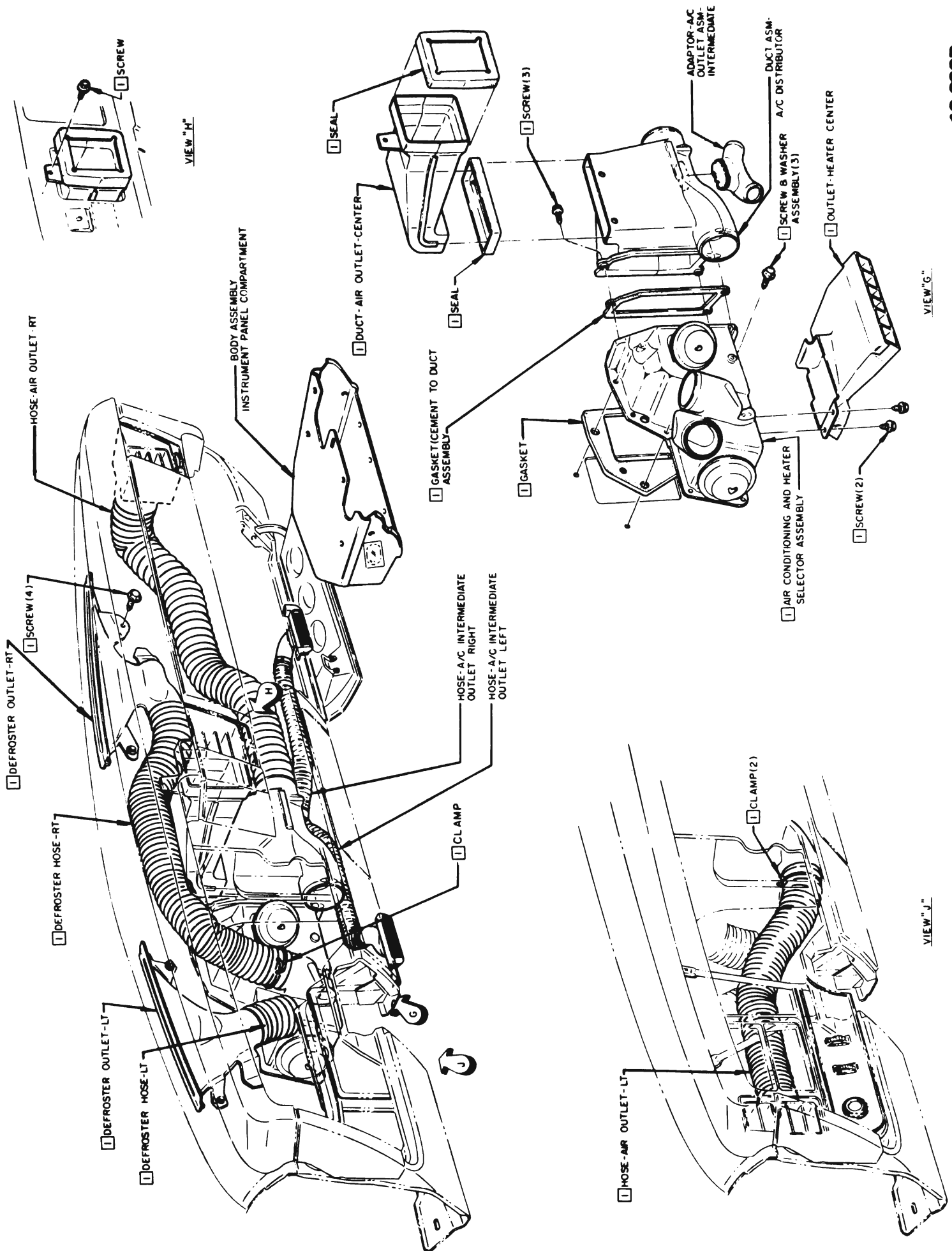

13-392B

Figure 13-140 Air Distributor Ducts and Hoses, 49000 Series

13-80 HEATER-AIR CONDITIONING SYSTEM

locate refrigerant leaks in the system. Loss of refrigerant is always indicative of a leak since refrigerant is not consumed and does not wear out.

1. **Open Flame Method** - This method utilizes a gas operated torch type leak detector (J-6084). Use of this method is recommended when checking for leaks in confined areas. To perform test, light torch and adjust to obtain a pale blue flame, approximately 3/8 inch in height, in burner.

Explore for leaks by moving end of search tube around suspected area. Check bottom of connections since Refrigerant-12 is heavier than air and will be more apparent at underside of fittings. The flame color will turn yellow-green when a small leak is detected. Large leaks will turn the flame blue or purple.

CAUTION: Do not breath fumes resulting from burning of refrigerant gas. These fumes are extremely poisonous.

When leak testing the POA valve, it is necessary to check only the hose coupling ends. When using the propane torch leak detector, no evidence of Refrigerant-12 should be present at the POA valve.

2. **Liquid Leak Detectors** - This method utilizes a solution which will bubble (soap solution) to signify a gas leak. Use of this method of checking is recommended for locating small leaks.

13-35 FUNCTIONAL TESTING SYSTEM

Functional testing is a measurement of the air conditioner system performance to determine if discharge air temperature, pressure in suction line, and pressure in discharge line are within specific limitations.

To perform functional test proceed as follows:

1. Remove protective caps from Schrader valve located on suction throttle valve and Schrader valve located on compressor discharge port.
2. Interconnect manifold and gage set (J-5725-01), gage charging lines (J-5418) and gage adapters (J-5420) to air conditioning system as shown in Figure 13-143.
3. Open doors and hood of car.
4. Set TEMPERATURE lever to extreme left position and FAN to "MAX". SELECTOR switch in "REC" position.
5. Idle engine at 2000 RPM in neutral.
6. Place a high volume industrial type fan in front of radiator grille to insure minimum differential between temperature of air passing through radiator grille and condenser, and temperature of air flow through cowl air inlet and past evaporator core.
7. Measure relative humidity and ambient temperature in immediate vicinity of car to be tested.

NOTE: The temperature obtained at the air outlets will be lower on dry days and higher on humid days.

8. Open all air conditioner outlets and measure temperature at right and left outlets.

9. Compare the actual pressures and temperatures with the pressures and temperatures indicated in Test I of **Functional Test Table** (see **Figure 13-144**).

If it appears from the test results that either the POA valve or the expansion valve is at fault, the following procedure will help determine which to replace.

- a. Check temperature door, make sure the door seals in the cool position, readjust the Bowden cable if necessary.
- b. Check air hoses and ducts for proper connections.
- c. Check the sight glass for "clear" condition and make sure compressor clutch is engaged.

After these basic visual checks, install evaporator and head pressure gages. Operate the engine at 1500 RPM, "REC" control setting and "LO" blower.

d. If evaporator pressure is 30 psi or less (and discharge air temperatures are too warm) replace the expansion valve.

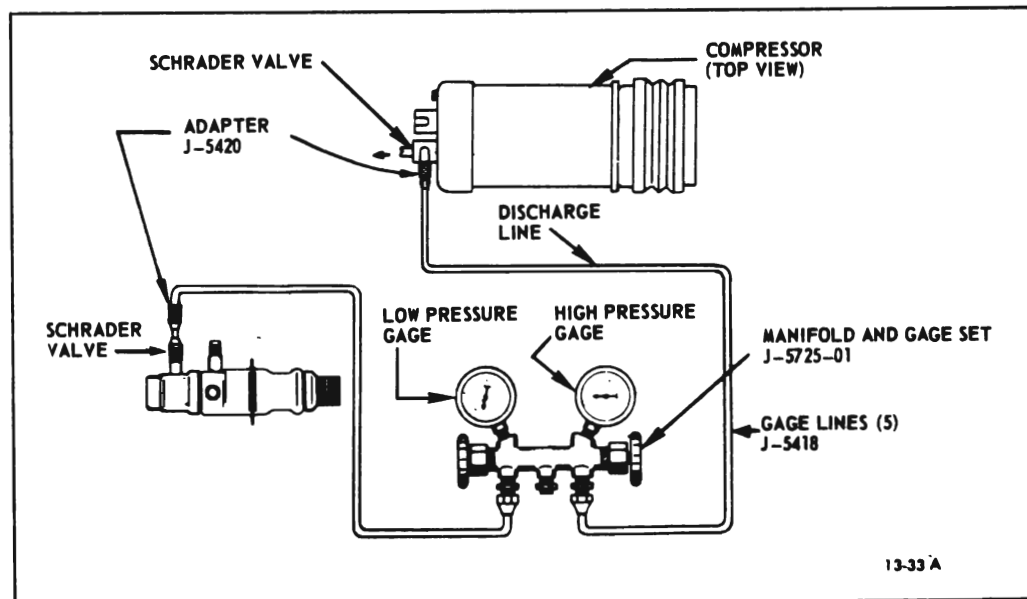

Figure 13-143 Functional Test Set-Up

e. If evaporator pressure is above 30 psi, even with blower wire disconnected, make sure the expansion valve feeler bulb is clamped tightly to the evaporator outlet pipe and the feeler bulb insulation is in place. If the bulb and insulation are OK,

replace the POA valve.

f. If evaporator pressure is 29 psi plus or minus 1 psi (and discharge air temperatures are abnormal), partially cover the condenser to obtain head pressure from 325 psi to

375 psi maximum. If evaporator pressure rises above 30 psi, change the expansion valve. If expansion pressure remains at 29 psi, install a new receiver dehydrator.

FUNCTIONAL TEST # 1						
Ambient Temperature (°F)	Evap. Pressure at POA Valve (PSIG)	Compressor Head Pressure (PSIG)		Right A/C Outlet Temp. (°F)	Left A/C Outlet Temp. (°F)	
All Series	All Series	43-44000 Series	45-46-48000 Series	49000 Series	43-44000 Series	45-46-48000 Series
70	28.5 - 30	150-225	160-195	39-43	39-42	38-41
80	28.5 - 30	200-245	180-235	40-45	40-43	40-43
90	28.5 - 30	240-290	200-280	40-45	43-45	40-45
100	28.5 - 30	270-330	230-310	42-48	45-48	42-47
110	28.5 - 30	310-345	270-335	46-53	47-52	44-52

FUNCTIONAL TEST # 2						
Ambient Temperature (°F)	Relative Humidity	Engine Speed (RPM)	Evap. Pres. at POA Valve (PSIG)	Compressor Head Pres. (PSIG)	Right A/C Outlet Temp. (°F Approx.)	Left A/C Outlet Temp. (°F Approx.)
All Series	All Series	43-48000 Series	All Series	43-48000 Series	43-48000 Series	43-48000 Series
90	Low	415-440	35	190	54	52
90	High	765-790	35	210	59	57
100	Low	620-670	35	230	55	54
100	High	950-1000	35	235	60	58
110	Low	775-825	35	270	58	58
110	High	1225-1275	35	320	59	59

NOTE: Functional test No. 2 is provided as a closer set of specifications designed to determine if the compressor is in fact at fault. Occasionally a system will check out according to the specifications in test No. 1; however, the customer will not be satisfied when car is returned to service. Under these circumstances the problem may be that the compressor is failing under load. Test No. 2 should show an inadequate compressor output if the compressor is malfunctioning.

Figure 13-144 Air Conditioner Functional Test Table

Sequence of Operation of Controls	Changes That Should Take Place in the System	Possible Cause of Malfunctions
<p>Pre Conditions— FAN switch— "OFF" TEMPERATURE lever — to extreme left.</p> <p>SELECTOR switch— "REC" Engine Idling. Move FAN switch to 1st detent.</p>	<p>Master vacuum switch will open and apply vacuum to recirculate port of outside-recirculate diaphragm. Outside-recirculate air door will open 1/4 of complete travel.</p> <p>The blower will operate at low blower speed and cold air will flow from air conditioner outlets.</p>	<p>Kinked, plugged or disconnected hose.</p> <p>Outside - rec. door diaphragm defective.</p> <p>Outside - rec. door sticking.</p> <p>Master vacuum switch defective.</p> <p>Defective vacuum storage tank.</p> <p>Vacuum hoses on wrong ports on vacuum diaphragm.</p> <p>Vacuum hoses incorrectly assembled to plug on vacuum switch.</p> <p>Defective compressor clutch switch.</p> <p>Defective resistor assembly.</p> <p>Defective blower motor.</p> <p>Brown wire not seated at blower switch connector.</p> <p>Loose or broken wire.</p> <p>Fuse</p> <p>Defective heater blower switch.</p> <p>NOTE: If only one blower speed is available regardless of switch position, it is likely resistor assembly coils are touching.</p> <p>NOTE: If air flows from the heater outlets on "A" & "E" series cars a loss of vacuum will cause air to flow out heater, or flows from both the heater and the A/C outlets it is possible that the spring which holds the door in position is broken.</p>

13-84 HEATER-AIR CONDITIONING SYSTEM

SEQUENCE OF OPERATION OF CONTROLS	CHANGES THAT SHOULD TAKE PLACE IN THE SYSTEM	POSSIBLE CAUSE OF MALFUNCTIONS
	The compressor clutch will engage.	Defective compressor clutch switch. Loose or broken wire. Brown wire not seated at blower switch connector. Defective compressor clutch coil. Compressor clutch ground wire broken. Engine harness connector disc or missed prong. Connector loose at compressor coil. NOTE: If neither the blower motor nor the compressor can be actuated, check the fuse and the blower switch.
Move the FAN switch thru 2nd, 3rd, and 4th detents	Blower will increase speed to low, medium and high.	Defective blower resistor assembly. Missed prong @ resistor or switch. Heater resistor connector under dash disconnected. Defective blower switch. NOTE: If no high blower speed, check A/C relay.
Move SELECTOR switch to "A/C."	Vacuum will be applied to outside air port of out-side-rec. diaphragm thereby fully opening door and decreasing air noise level in the car.	Kinked hose. Outside – rec. door diaphragm defective. Outside – rec. door sticking. No vacuum to diaphragm.
Move SELECTOR switch to "VENT."	Compressor clutch will disengage.	Selector switch defective.
Move SELECTOR switch to "DEICE."	Air will be directed to defroster outlets.	Selector switch defective. No vacuum to diaphragm (43-44-45-46-48000). Defroster door diaphragm defective.

Sequence of Operation of Controls	Changes That Should Take Place in the System	Possible Cause of Malfunctions
<p>Move SELECTOR switch to "HEAT".</p> <p>Move TEMPERATURE lever to extreme right.</p>	<p>Vacuum will be applied to htr. - A/C diaphragm and door will reposition directing air out of heater outlets.</p> <p>Vacuum will be applied to diaphragm of water valve and open valve permitting coolant to circulate thru heater core. Warm air will flow from under outlets.</p>	<p>Defective wiring.</p> <p>Kinked or pinched hoses.</p> <p>Htr. - A/C Mode door defective.</p> <p>No vacuum to diaphragm (45 - 46 - 48000).</p> <p>Sticking htr. - A/C Mode door.</p> <p>Kinked vacuum hoses.</p> <p>Defective water valve vacuum switch.</p> <p>Incorrect vacuum hose connection.</p> <p>Kinked water hoses.</p> <p>Defective water valve.</p> <p>Plugged heater core.</p> <p>Plugged or defective water pump.</p>

13-37 HEATER-AIR CONDITIONER REFRIGERANT CIRCUIT TROUBLE DIAGNOSIS CHART

