

# SECTION D

## INSTRUMENT PANEL— SKYLARK

### CONTENTS

Division	Subject	Paragraph
I	SPECIFICATIONS AND ADJUSTMENTS:	
II	DESCRIPTION AND OPERATION: Description of Instrument Panel- Skylark .....	120-19
III	SERVICE PROCEDURES: Removal and Installation of Instrument Panel Parts — Skylark .....	120-20

### DIVISION II

### DESCRIPTION AND OPERATION

#### 20-19 DESCRIPTION OF INSTRUMENT PANEL - SKYLARK

##### a. Description of Instrument Cluster Assembly

The instrument cluster assembly is comprised of three individual units. See Figure 120-17.

The left hand unit houses the fuel gauge dash unit, indicator lights and/or oil pressure gauge and ammeter. The center unit contains the speedometer. The right hand unit contains the clock or tachometer when specified.

The generator, temperature and oil pressure indicators use red lights to warn the driver of conditions other than normal when the engine is running.

Each unit contains its own printed circuit fastened by three screws and bulb sockets on the rear of the housing.

A rectangular pin type disconnect plug, which is part of the instrument panel wiring harness, attaches to the printed circuit contacts. The pins are positioned to insure correct assembly of the disconnect plug in the printed circuit.

If the printed circuit should become defective, it should be replaced as it is not practical to repair it.

To remove the printed circuit, it is

not necessary to remove the instrument cluster units.

**CAUTION:** *Disconnect battery ground cable from battery terminal before removing any instrument panel unit or wiring.*

##### b. Generator Charge Indicator

The red "GEN" warning light should light when the ignition is turned "ON" and before the engine is started; if not lighted, either the bulb is burned out or the indicator light wiring has an open circuit. After the engine is started, the "GEN" light should be out at all

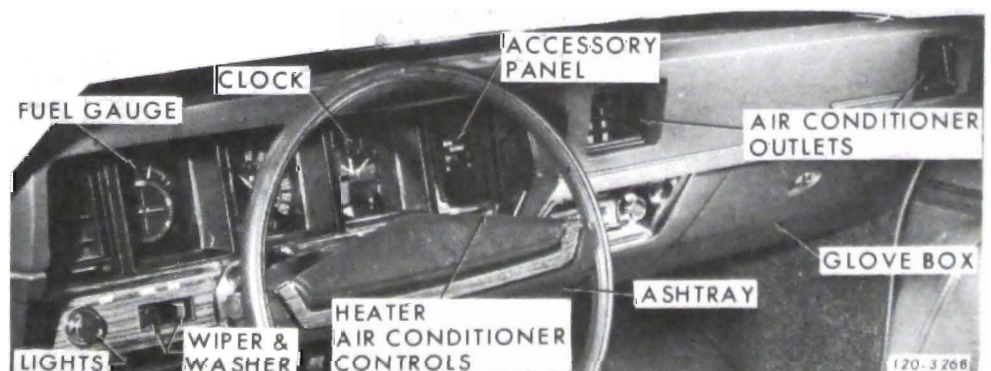

Figure 120-17 Instrument Panel - 43-44000

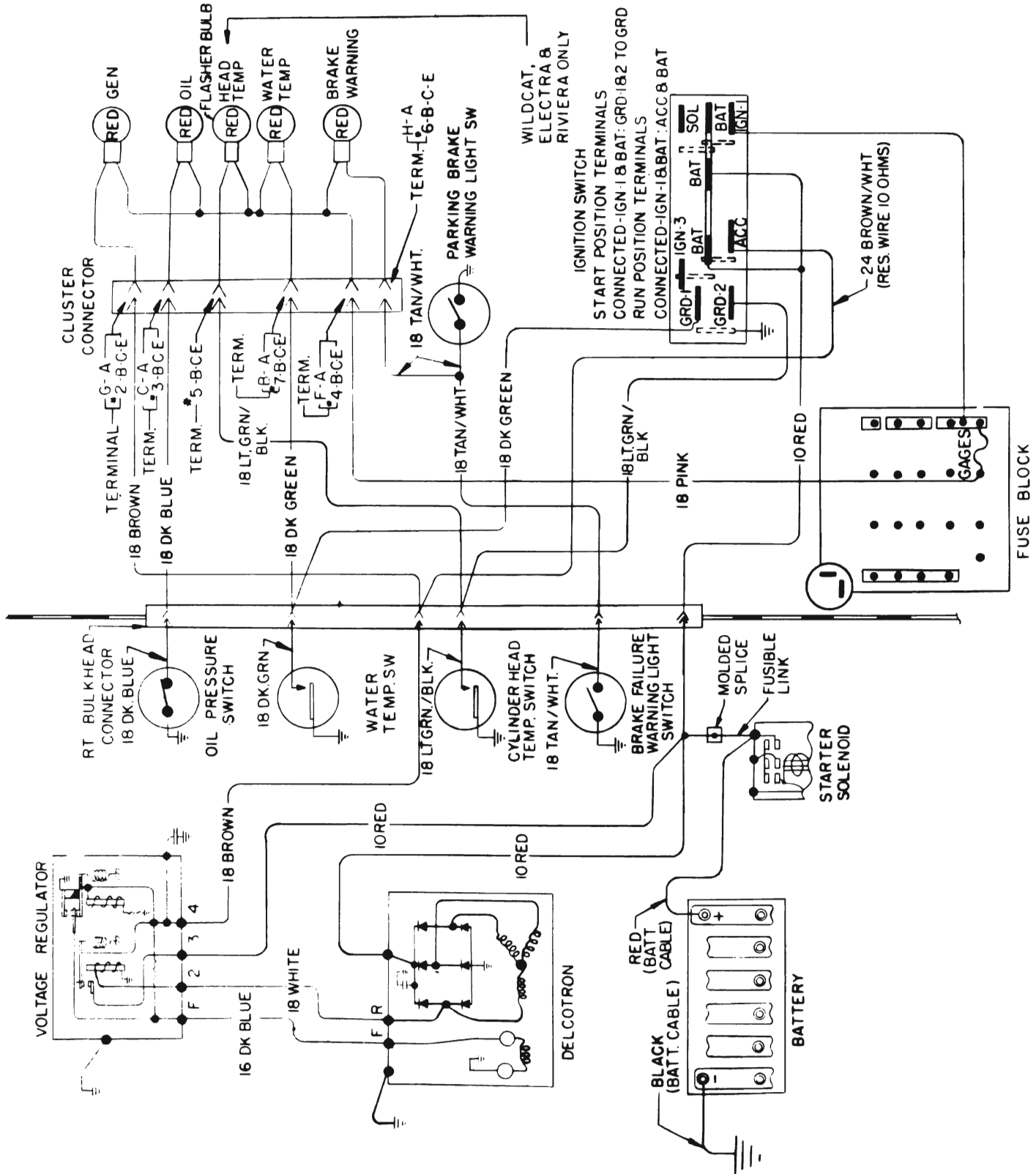
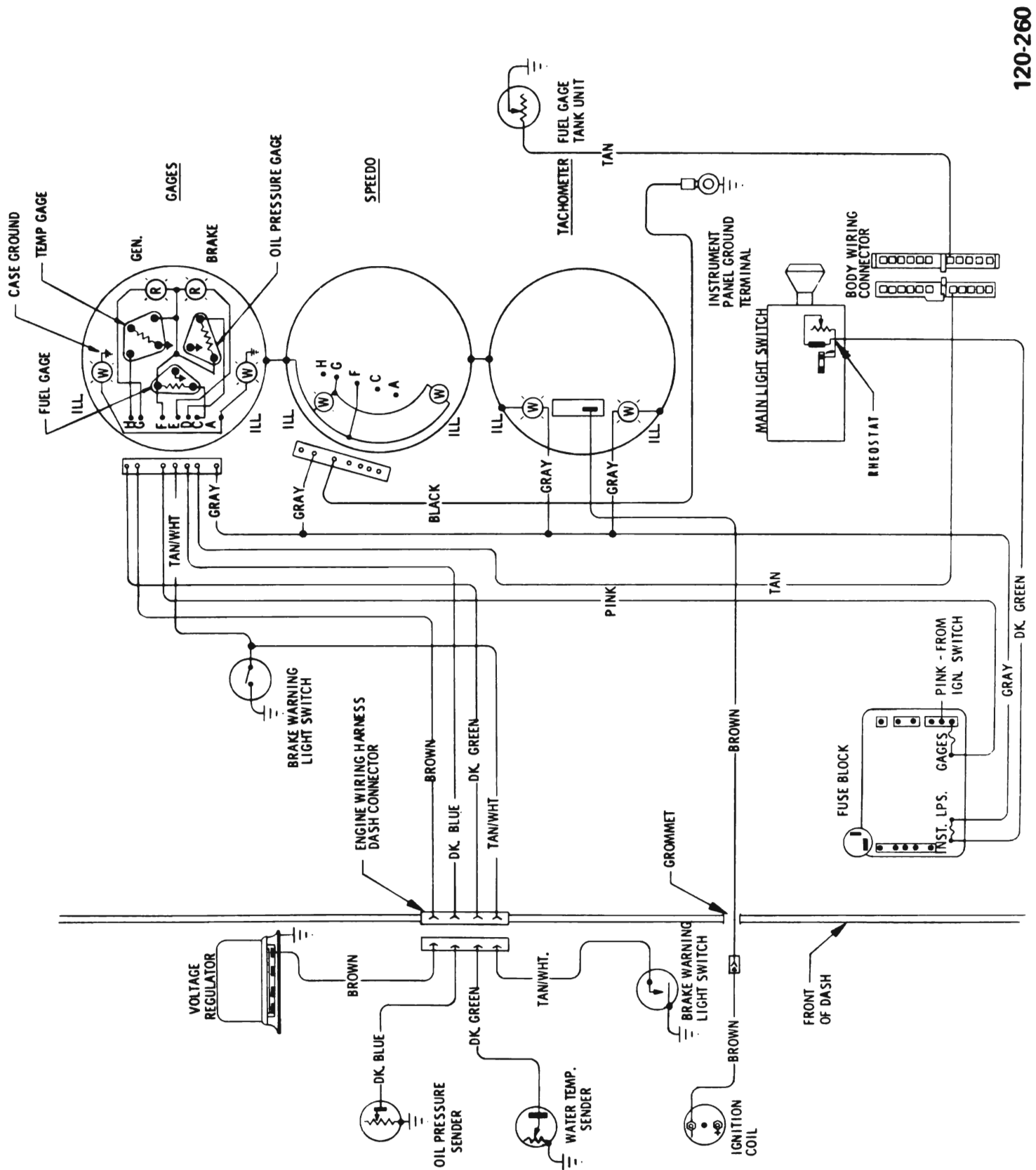

Figure 120-18 Instrument Warning Light Wiring Diagram



120-260

Figure 120-18A Instrument Panel Gauges

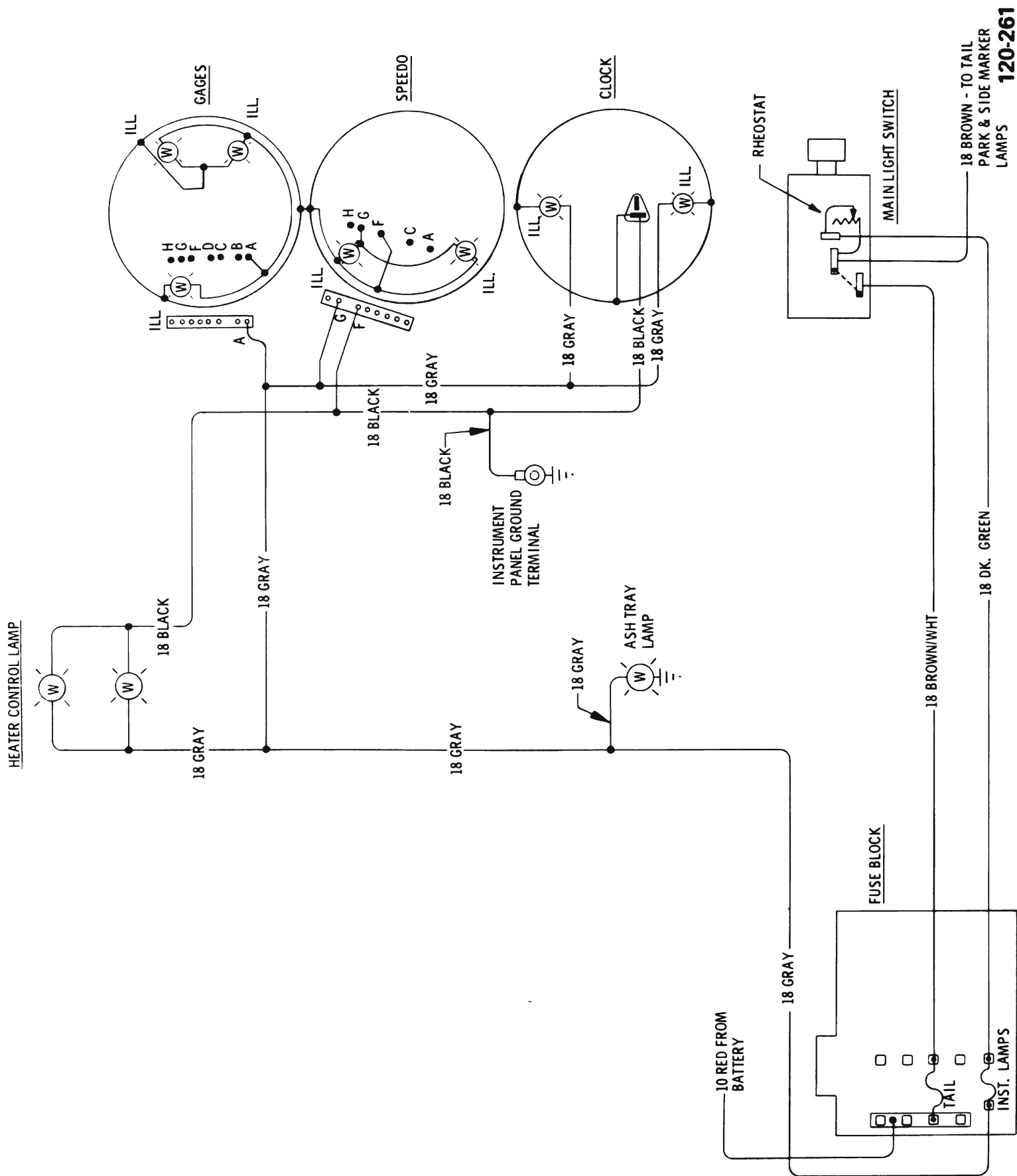

Figure 120-18B Instrument Panel Illumination Lights

120-261

times; if the light comes on, the generator belt may be loose or missing, the generator or regulator may be defective, or the charging circuit may be defective.

To trace the generator indicator light circuit, see Figure 120-18.

With the ignition switch turned on (engine not running), current flow is through the ignition switch, through the generator light in the instrument cluster, in the "4" terminal of the regulator, through the lower contacts of the voltage regulator (held closed by the spring), out the "F" terminal, in the "F" terminal of the generator, through the brush and slip ring, through the field, through another brush and slip ring to ground.

Before the engine is started, the generator light should glow at about 1/2 brightness. This is because the voltage in the circuit before the light is about 12 volts, but the voltage at the "4" terminal after the light is about 5 volts. This makes the effective voltage across the generator light approximately 7 volts for about 1/2 brightness.

After the engine is started, the voltage put out by the generator immediately closes the field relay. This causes battery voltage from the "3" terminal to be present at the "4" terminal. See Figure 120-18. Since battery voltage is present on both sides of the generator light, the light goes out. If the generator light comes on with the engine running, the charging circuit should be tested at the first opportunity to determine the cause of the trouble. See paragraph 68-9.

#### c. Oil Pressure Indicator

The engine oil pressure indicator light is controlled by a pressure operated switch located at the right front of the engine. This light should come on when the ignition is turned "on" and the engine is not running. If not lit, either the bulb is burned out, the wiring has an open circuit or the oil switch is defective.

If the engine oil pressure drops below a safe level during operation, the circuit is completed through the pressure switch to ground, and the "Oil" indicator light in the cluster will be turned on. See Figure 120-18.

If the "Oil" indicator stays on or comes on when the engine is running at speeds above idle, stop engine immediately and find out reason. The following may be the cause, rather than low oil pressure.

1. Wiring circuit between oil pressure switch and light grounded. Remove connector from pressure switch, if light stays on trouble is in wiring.

2. Switch defective. Replace switch.

#### d. Temperature Indicator

A temperature switch located in right front of the intake manifold controls the operation of the "HOT" indicator light located in instrument cluster.

If the engine cooling system is not functioning properly and the water temperature should reach 253°F., the "HOT" indicator will be turned on by the temperature switch. As a test circuit to check whether the "HOT" indicator bulb is functioning properly, a light wire which leads to the "GND" terminal of the ignition switch is connected into the temperature switch circuit. See Figure 120-18. When the ignition is in the "START" position (engine cranking), the "GND" terminal is grounded inside the switch and the "HOT" bulb will be lit. When the engine is started and the ignition switch is in the "ON" position, the test circuit is opened and the bulb is then controlled by the temperature switch.

#### e. Trouble Diagnosis - Generator, Oil Pressure and Temperature Indicators

Use Figure 120-18 to trace wiring circuits for indicator lights. To determine if there is a ground in the indicator light circuit, remove connector from control switch. If light stays on, trouble is in circuit.

## DIVISION III

### SERVICE PROCEDURES

#### 120-20 REMOVAL AND INSTALLATION OF INSTRUMENT PANEL PARTS - SKYLARK

Before starting any instrument repair, always disconnect battery ground cable.

##### a. R and I Instrument Cluster Assembly

**CAUTION:** *If equipped with cruise control, upper speedo cable must be disconnected from transducer to prevent damage when cluster housing is pulled back.*

1. Remove glove box (9 screws).
2. Remove instrument panel upper cover by removing two screws thru cluster housing and two nuts above glove box opening. Pull cover rearward to disengage three guide pins from clips.
3. Remove steering column opening filler (four screws). (A/C cars, drop left air conditioner plastic duct by removing two screws and disconnecting inner end from center distribution duct.)
4. Lower steering column by removing two nuts and disconnecting shift indicator link.
5. Pad steering column to avoid marring paint.
6. Pull instrument cluster housing back after removing 8 screws. Rest housing on steering column and rotate so that back of cluster is visible.
7. Install instrument cluster by reversing above steps.

##### b. R and I Speedometer

1. To remove a speedometer, first

Complaint	Possible Cause
<p><b>1. GENERATOR INDICATOR</b></p> <p>Light on, ignition "Off"</p> <p>Light not lit, ignition "On" and engine not running.</p> <p>Light on, engine running.</p>	<p>Positive diode shorted.</p> <p>Bulb burned out. Replace.</p> <p>Positive diode shorted.</p> <p>Open in light circuit. Locate and correct.</p> <p>No generator output. Check output, paragraph 68-9.</p> <p>Loose or broken generator belt.</p>
<p><b>2. OIL PRESSURE INDICATOR</b></p> <p>Light not lit, ignition "On" and engine not running.</p> <p>Light on, engine running above idle speed.</p>	<p>Bulb burned out. Replace.</p> <p>Open in light circuit. Locate and correct.</p> <p>Oil pressure switch defective. Replace.</p> <p>Wiring between light and switch grounded. Locate and correct.</p> <p>Oil pressure switch defective. Replace.</p> <p>Low oil pressure. Locate cause and correct.</p>
<p><b>3. TEMPERATURE INDICATOR</b></p> <p>Light not lit when cranking engine.</p> <p>Light on, engine running.</p>	<p>Bulb burned out. Replace.</p> <p>Open in light circuit. Locate and correct.</p> <p>Ignition switch defective. Replace.</p> <p>Wiring between light and switch grounded. Locate and correct.</p> <p>Temperature switch defective. Replace.</p> <p>Cooling system water temperature above 248°F. Find cause and correct.</p> <p>Ignition switch defective. Replace.</p>

Figure I20-19 Indicator Trouble Diagnosis - 43-44000

327B

remove instrument cluster housing as described in subparagraph a, above.

2. Disconnect speeds cable by depressing "quick connect" retainer spring.

3. Disconnect all electrical connections to unit.

4. Remove 3 nuts from speedometer back and remove speedometer.

5. Install speedometer by reversing above steps.

**c. R and I Speedometer Printed Circuit**

1. To remove a printed circuit, first remove instrument cluster housing as described in subparagraph a, above.

2. Remove light bulb sockets.

3. Remove 3 screws from printed circuit and remove printed circuit.

4. Install printed circuit by reversing above steps.

**d. R and I Tachometer**

1. To remove tachometer, first remove instrument cluster housing as described in subparagraph a.

2. With instrument cluster housing pulled back and rotated, remove three gauge unit screws and remove unit.

3. Disconnect electrical connections.

4. Install tachometer by reversing above steps.

**e. R and I Fuel Gauge DASH Unit and/or Printed Circuit**

1. Follow procedure for removal of instrument cluster as described in subparagraph a, for the first four steps only.

5. Remove light switch assembly.

6. Remove lower nut and loosen two upper nuts. Disconnect all electrical connectors.

7. Remove fuel gauge dash unit.

8. Remove printed circuit from rear of unit by first removing light bulb sockets and three screws holding printed circuit to rear of unit.

9. Install fuel gauge unit and/or printed circuit by reversing above steps.

**f. R and I Radio**

1. Remove radio knobs and escutcheons. Remove two 5/8 hex nuts.

2. Remove filler plate by removing 2 screws.

3. Remove ash tray. Remove ash tray slide by removing 4 screws.

4. Remove radio support by removing 2 screws. (A/C cars, remove center distributor duct by removing 2 screws and 2 hose clamps.)

5. Remove 2 nuts attaching radio face to instrument panel and move radio downward. Disconnect radio antenna lead and wiring connector and remove radio.

6. Install radio by reversing above steps.

**g. R and I Front Radio Speaker**

1. Remove radio knobs and escutcheons. Remove two 5/8 hex nuts and two screws from radio filler plate and remove plate. (Do not remove radio).

2. Unplug speaker connector from radio.

3. Remove screw at speaker bracket and remove speaker through radio filler plate opening.

4. Install speaker by reversing above steps.

**NOTE:** *In A/C car, remove radio as explained in subparagraph f. Remove instrument panel upper cover as explained in subparagraph a, and remove two screws at upper center A/C duct and remove duct.*

**h. R and I Light Switch**

1. Pull switch out to last notch, then depress latch button and pull knob and rod assembly out of switch. (A/C cars, first remove left duct by removing 2 screws and 2 hose clamps.)

2. Remove switch escutcheon.

3. Pull switch down as far as possible and unplug from connector.

4. Install light switch by reversing above steps.

**i. R and I Windshield Wiper-Washer Switch Assembly**

1. Remove steering column opening filler by removing 4 screws. (In A/C cars, remove left duct by removing 2 screws and 2 hose clamps.)

2. Unplug connectors from switch assembly.

3. Remove switch assembly by removing three screws.

4. Install wiper-washer switch assembly by reversing above steps.

**j. R and I Cigar Lighter Case**

1. Disconnect cigar lighter feed and ground wires. (In A/C cars, remove left duct by removing two screws and two hose clamps.)

2. Unscrew cigar lighter retainer (under instrument panel) from lighter case and remove retainer.

3. Remove cigar lighter element and knob, case and escutcheon.

4. Install cigar lighter parts by reversing above procedure.

**k. R and I Accessory Switch**

1. Pry switch cover plate from face of cluster housing.

2. Remove 2 retaining screws from switch.

3. Pull switch from connector (connector is retained in cluster housing).

4. Install switch by reversing above procedure.

**l. R and I Horn Relay - Buzzer Assembly**

1. Remove radio knobs and escutcheons. Remove two 5/8 hex nuts.

2. Remove radio filler plate by removing 2 screws.

3. Find relay mounted on vertical support to right of filler plate opening. Remove relay by removing 2 screws.

4. Install horn relay-buzzer by reversing above procedure.

**m. R and I Clock**

1. Disconnect battery. ) 2. Remove steering column opening filler (four screws). (A/C cars, drop left air conditioner plastic duct by removing two screws and disconnecting inner end from center distribution duct).

3. Lower steering column by removing two nuts and disconnecting shift indicator link.

**20-00 REPAIRMENT PANEL - SEVLAKI**

---

4. Disconnect battery cable from  
battery control.

area panel

7. Remove dash unit

5. Remove the control from upper  
control and lower unit from main.

6. Remove lower unit and install the  
top unit on dash unit. Disconnect all  
electrical connections.

8. Install dash unit by reversing  
above steps.



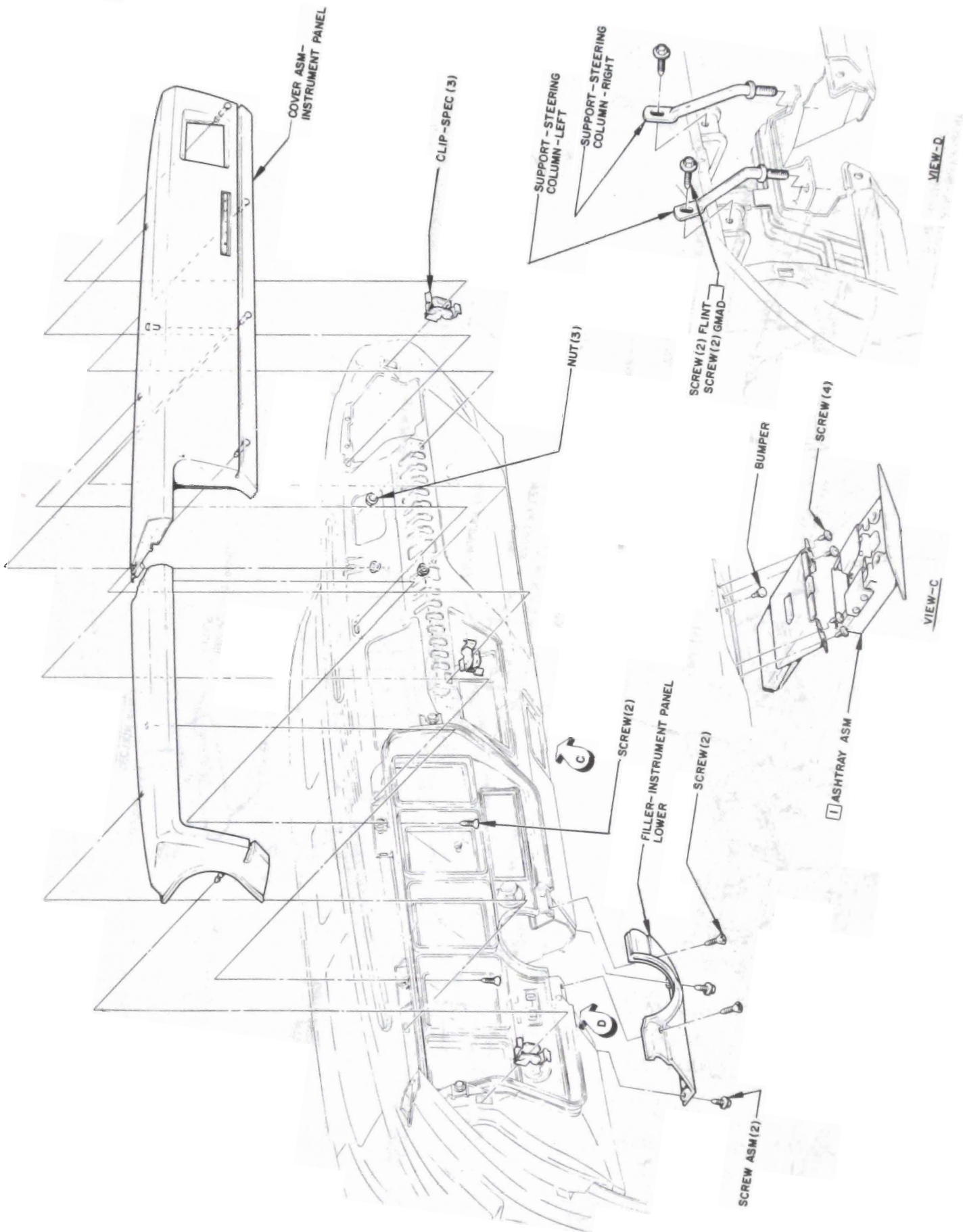

120-3288

Figure 120-20 Instrument Panel Cover and Ash Tray Installation 43-44000

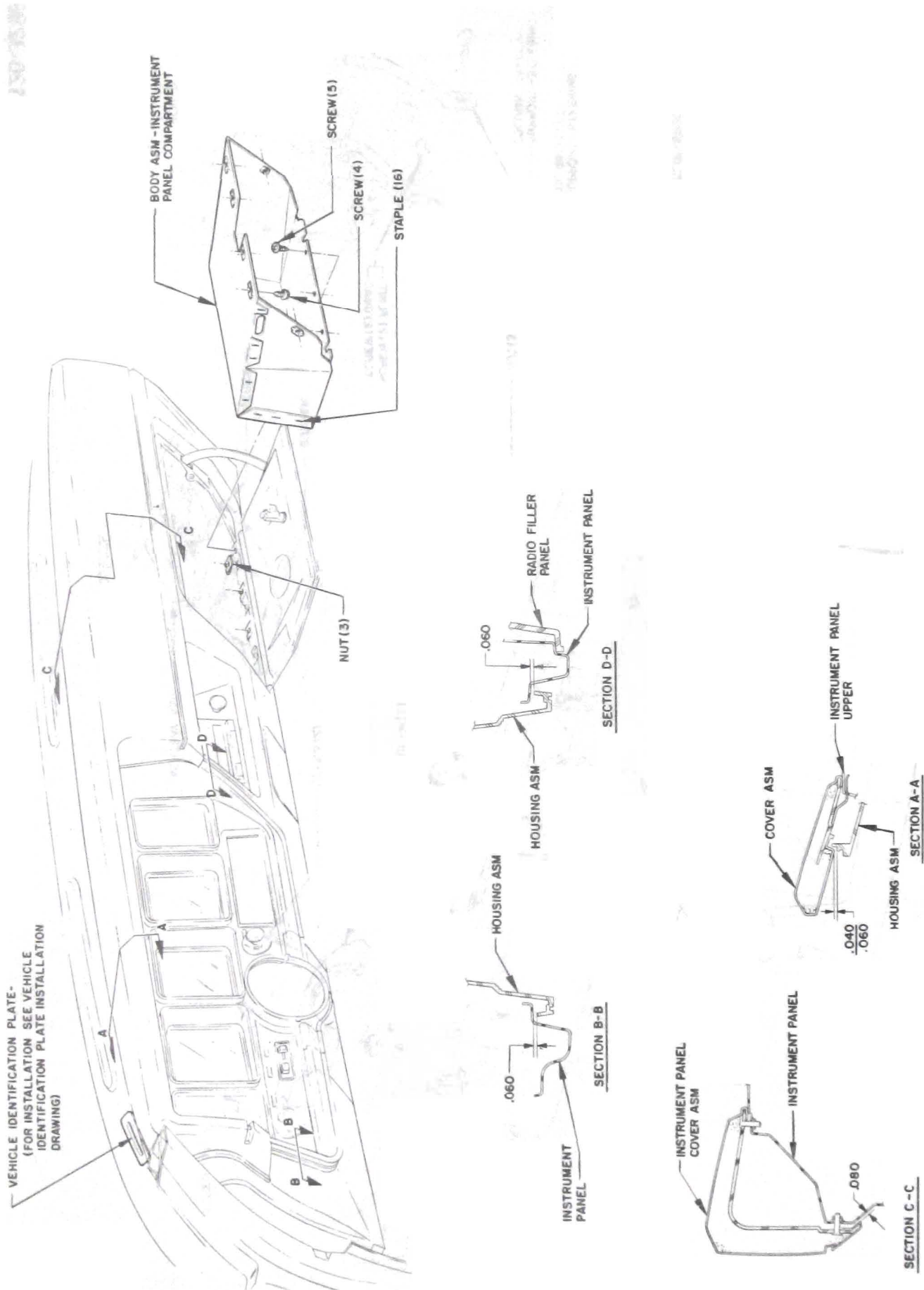

120-329B

Figure 120-21 Glove Box Installation 43-44000

150-281D

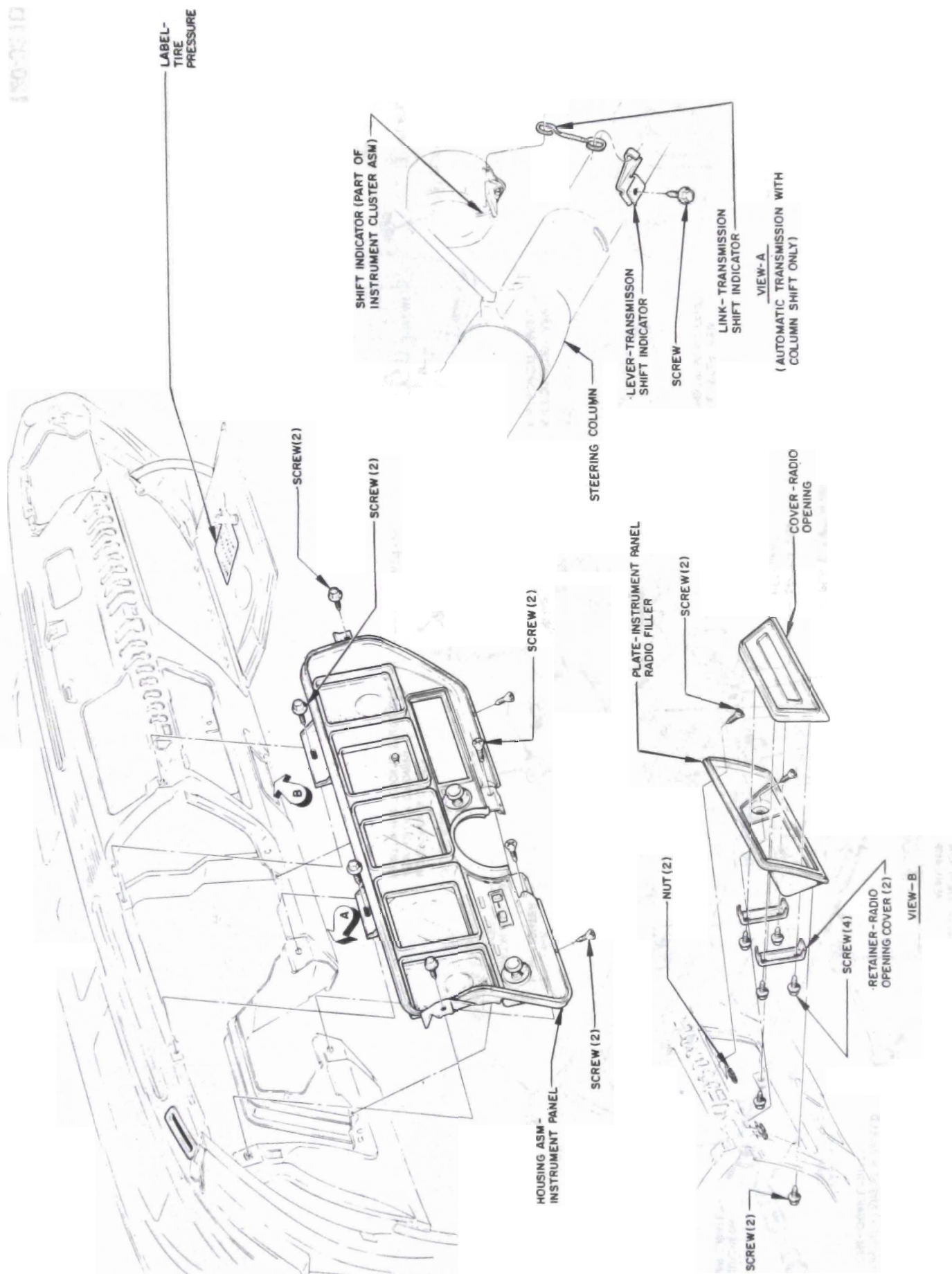

120-330B

Figure 120-22 Instrument Housing Installation 43-44000

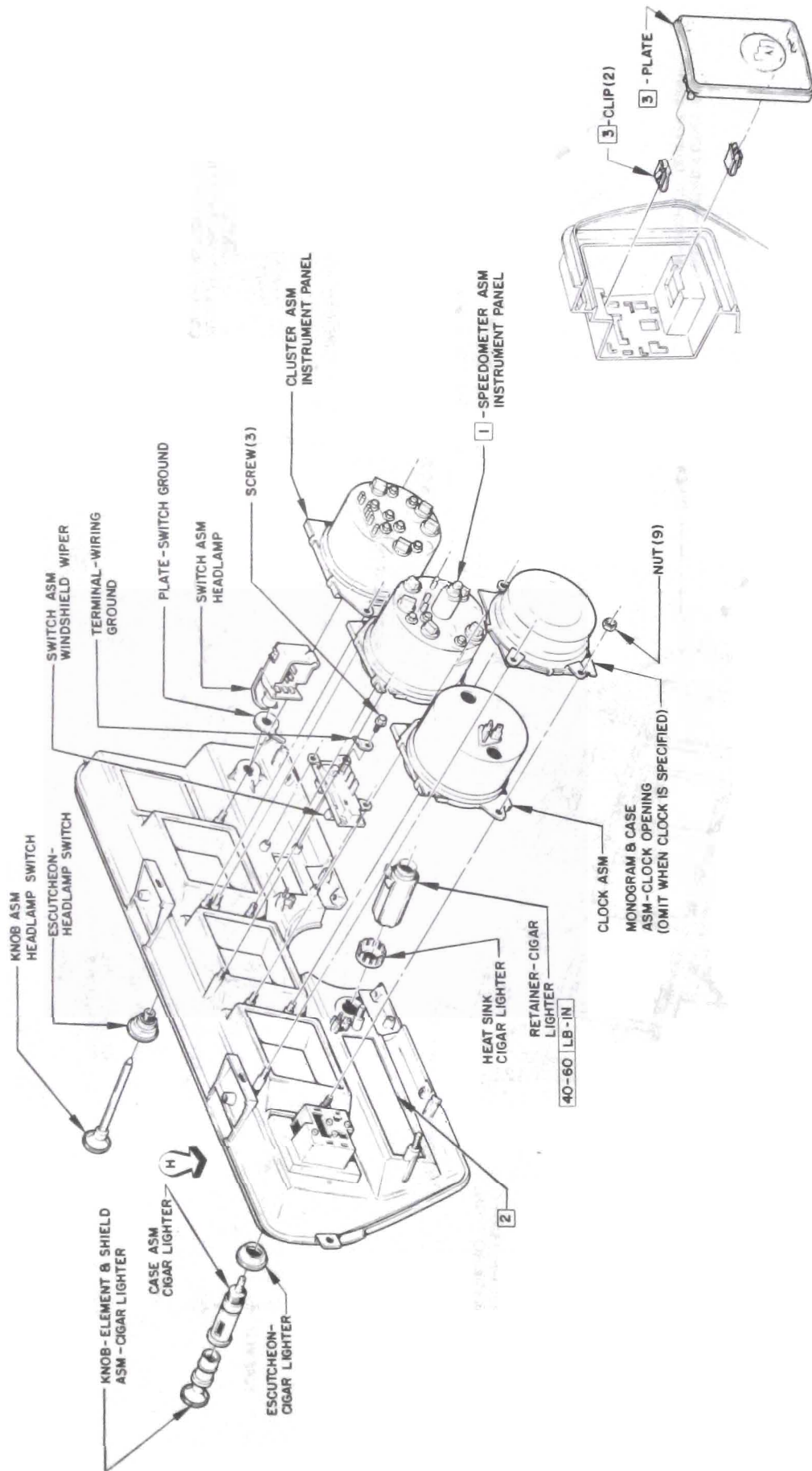

VIEW-H

120-331D

Figure 120-23 Instrument Cluster, Cigar Lighter, Clock and Switches Installation 43-44000



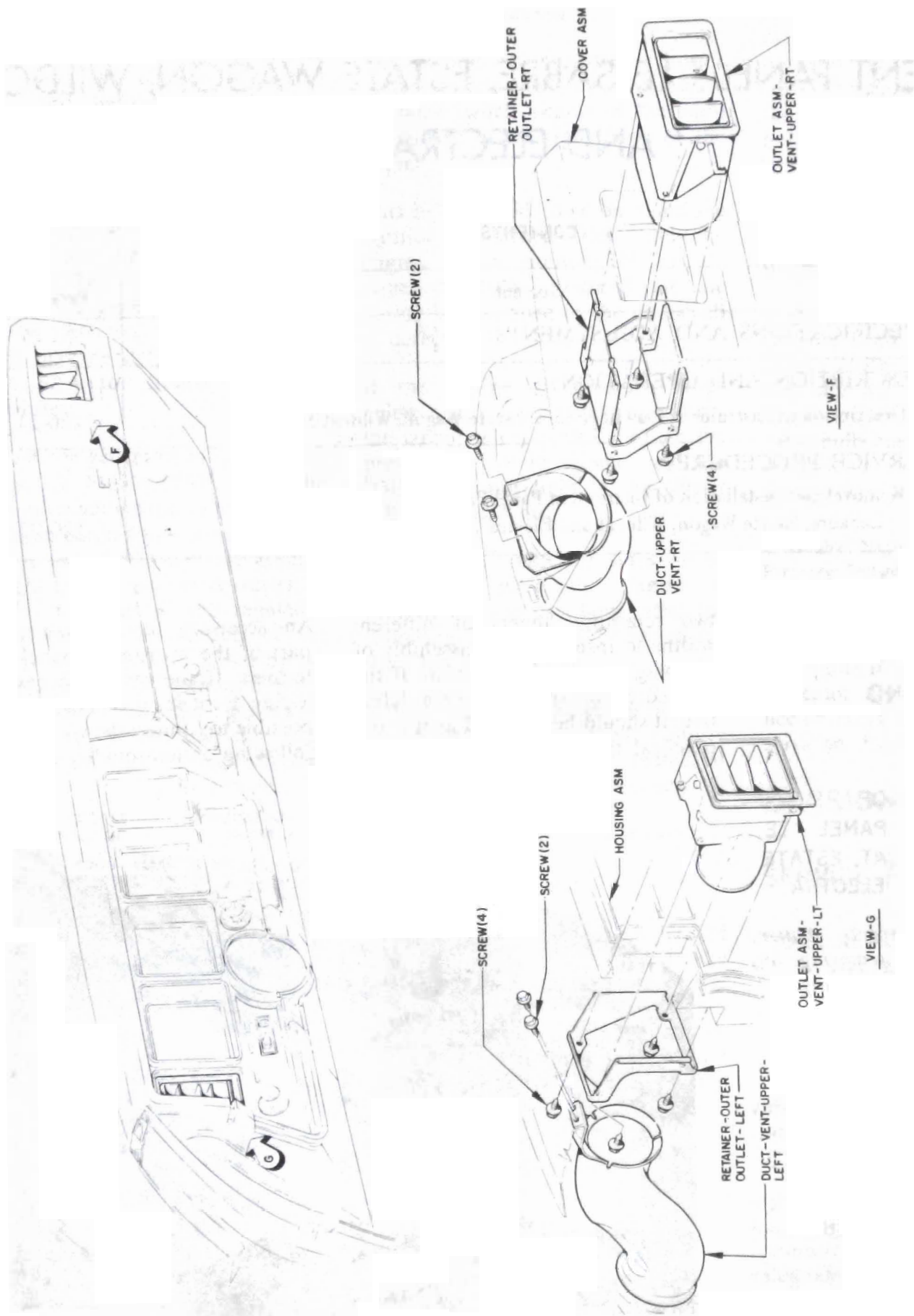

120-331C

Figure 120-24 Instrument Panel Upper Ventilation - 43-44000