

SECTION B

HEATER SYSTEM (45-46-48000 SERIES)

CONTENTS

Division	Subject	Paragraph
I	SPECIFICATIONS AND ADJUSTMENTS: General Specifications Adjustment of TEMPERATURE Selector Lever and Temperature Door..	12-11 12-12
II	DESCRIPTION AND OPERATION: Description of System..... Operation of Controls.....	12-13 12-14
III	SERVICE PROCEDURES: Removal and Installation of Heater Control Assembly..... Removal and Installation of Blower Motor or Blower Motor and Air Inlet Assembly..... Removal and Installation of Heater Assembly or Heater Core.....	12-15 12-16 12-17
IV	TROUBLE DIAGNOSIS: Heater-Defroster Trouble Diagnosis.....	12-18

DIVISION I SPECIFICATIONS AND ADJUSTMENTS

12-11 GENERAL SPECIFICATIONS

Recommended Coolant	Ethylene-glycol Base
Thermostat Opening Temperature.....	190°
Cooling System Capacity with Heater (Quarts)	
45000 Series	13.2
46-48000 Series	19.7
Blower Motor Type.....	12 VDC
Blower Motor Fan.....	Squirrel Cage

12B-1

12-12 ADJUSTMENT OF TEMPERATURE SELECTOR LEVER AND TEMPERATURE DOOR

The control cable should be adjusted when equal springback is not ob-

tained at both ends of lever travel. This adjustment should also be made when the heater assembly has been removed or when the temperature door does not open sufficiently to permit maximum air flow.

To adjust, position the TEMPERATURE lever to the "COOL" position and rotate the control cable adjuster nut until equal springback is obtained at both ends of lever travel. See Figure 12-10.

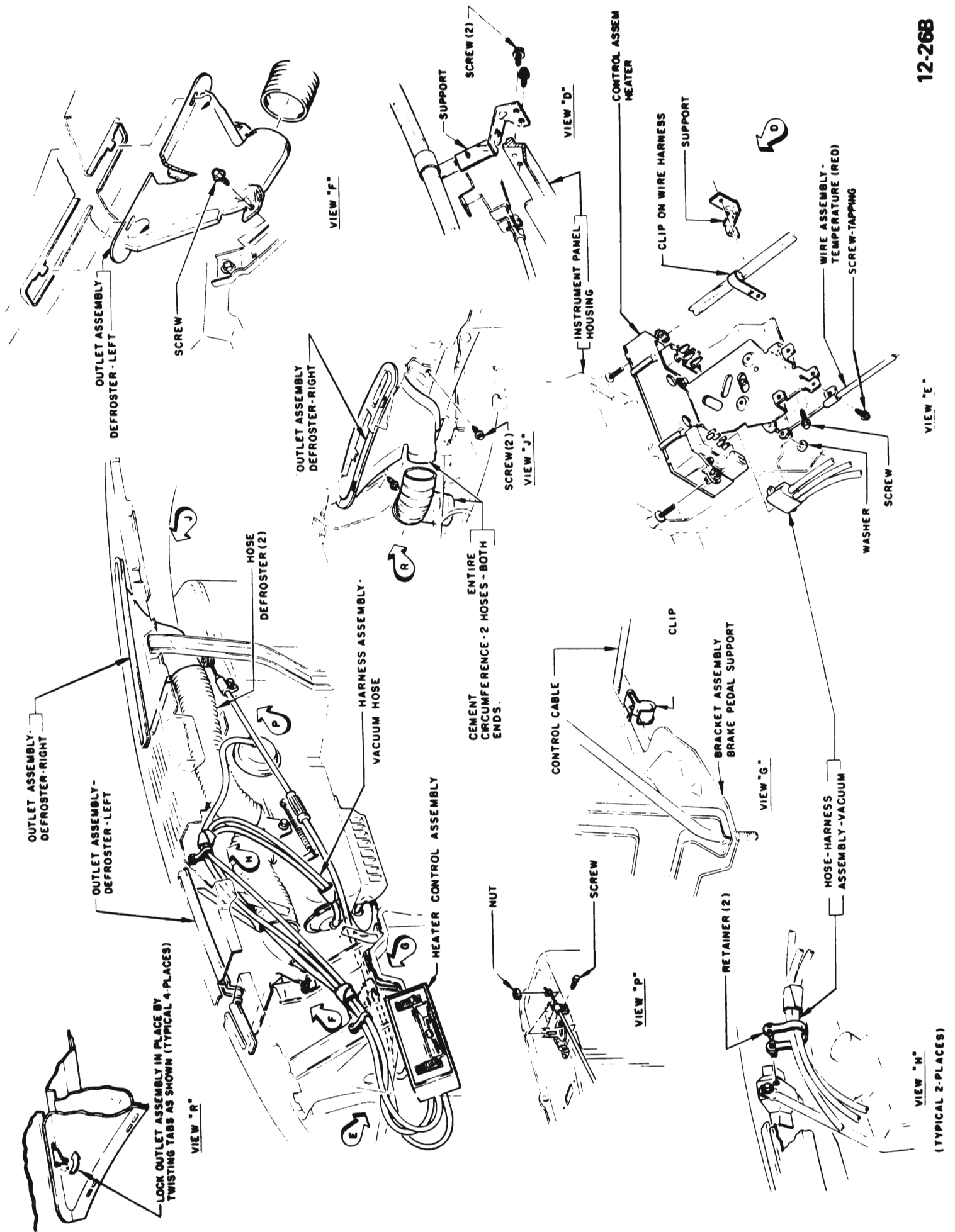

12-26B

Figure 12-10 Heater Control Wire and Defroster Hose Installation

12-12 HEATER SYSTEM (45-46-48000 SERIES)

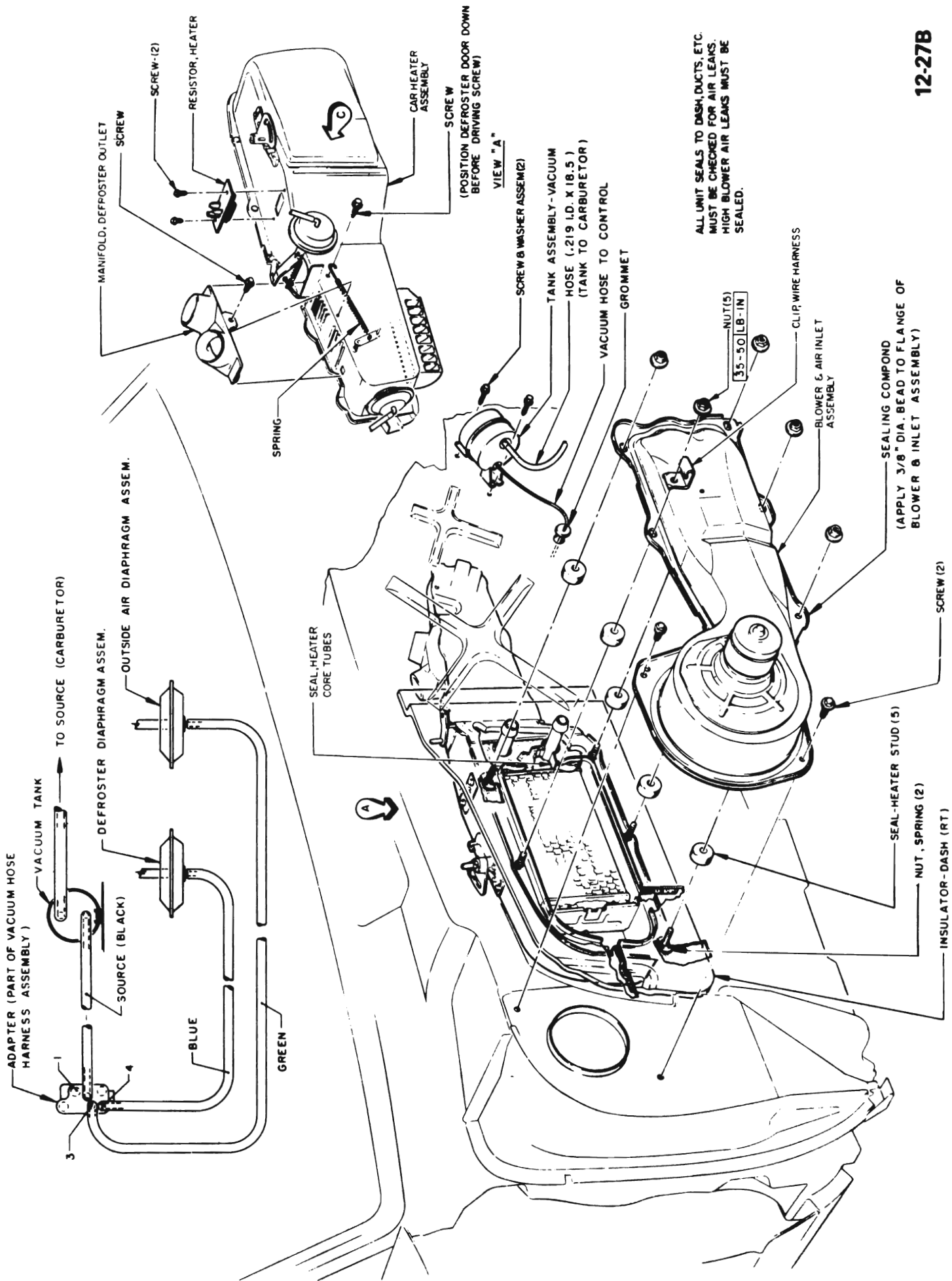

ALL UNIT SEALS TO DASH, DUCTS, ETC. MUST BE CHECKED FOR AIR LEAKS. HIGH BLOWER AIR LEAKS MUST BE SEALED.

12-27B

Figure 12-11 Heater Installation

DIVISION II

DESCRIPTION AND OPERATION

12-13 DESCRIPTION OF SYSTEM

The heater system is an air mix type system in which outside air is heated and then mixed in varying amounts with cooler outside air to attain the desired air temperature. The system consists basically of three parts: (1) the blower and air inlet assembly, (2) the heater assembly and (3) the heater control assembly (see Figure 12-11). The operation of the system is as follows:

1. Blower and Air Inlet Assembly- The blower and air inlet assembly draws outside air through the outside air inlet grille located forward of the windshield reveal molding and channels the air into the heater assembly. The operation of the blower motor is controlled by a FAN switch on the heater control. The motor is connected in series with the four position FAN switch and also the blower resistor assembly. See Figure

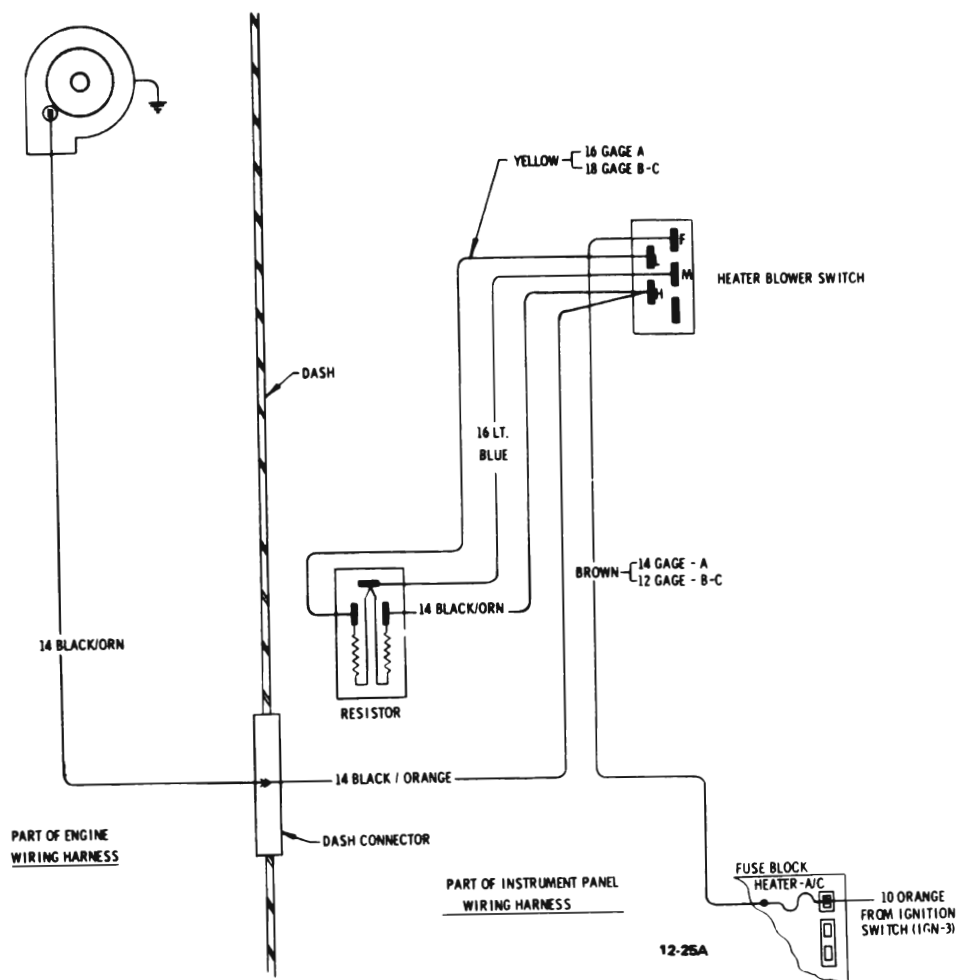

Figure 12-12 Heater System Wiring Diagram

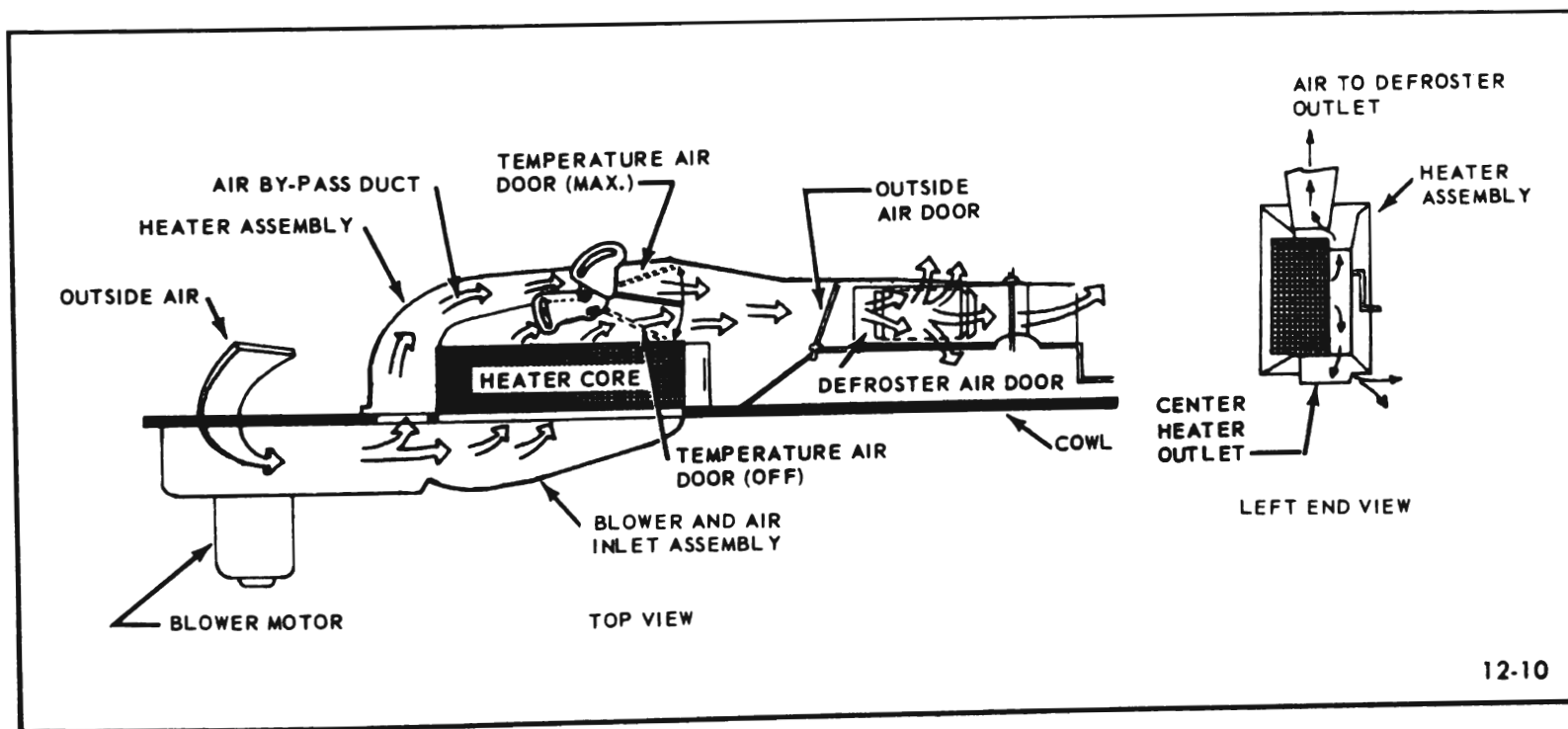
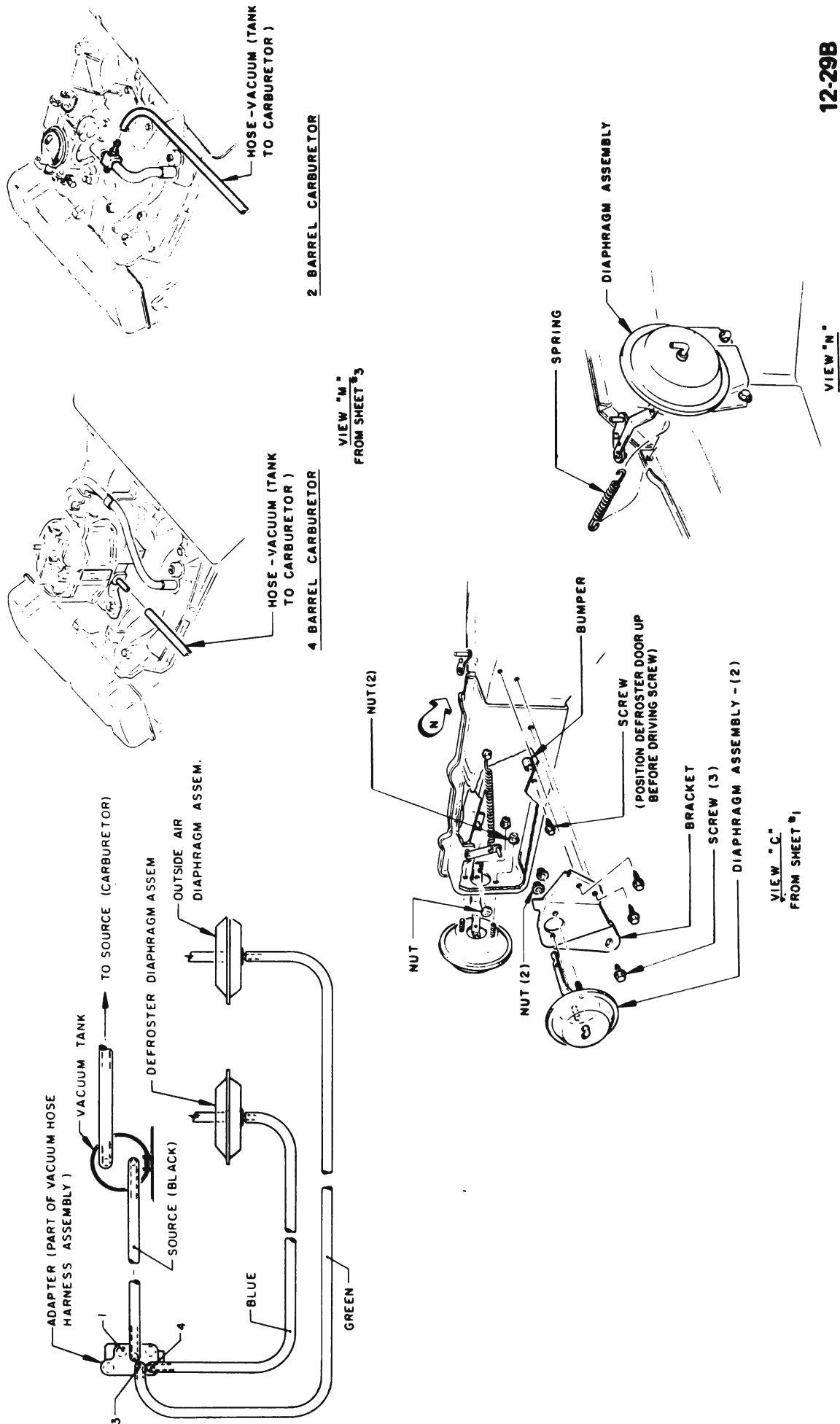

Figure 12-13 Heater System Air Flow

12-14 HEATER SYSTEM (45-46-48000 SERIES)



12-29B

Figure 12-14 Heater Hose (Water) Installation

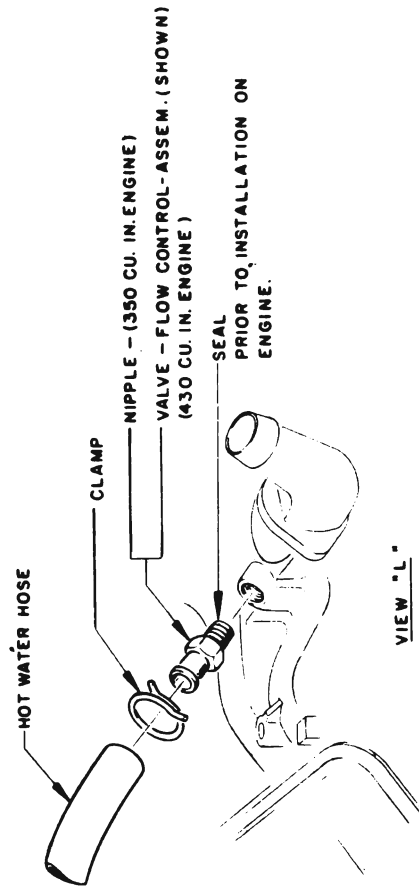
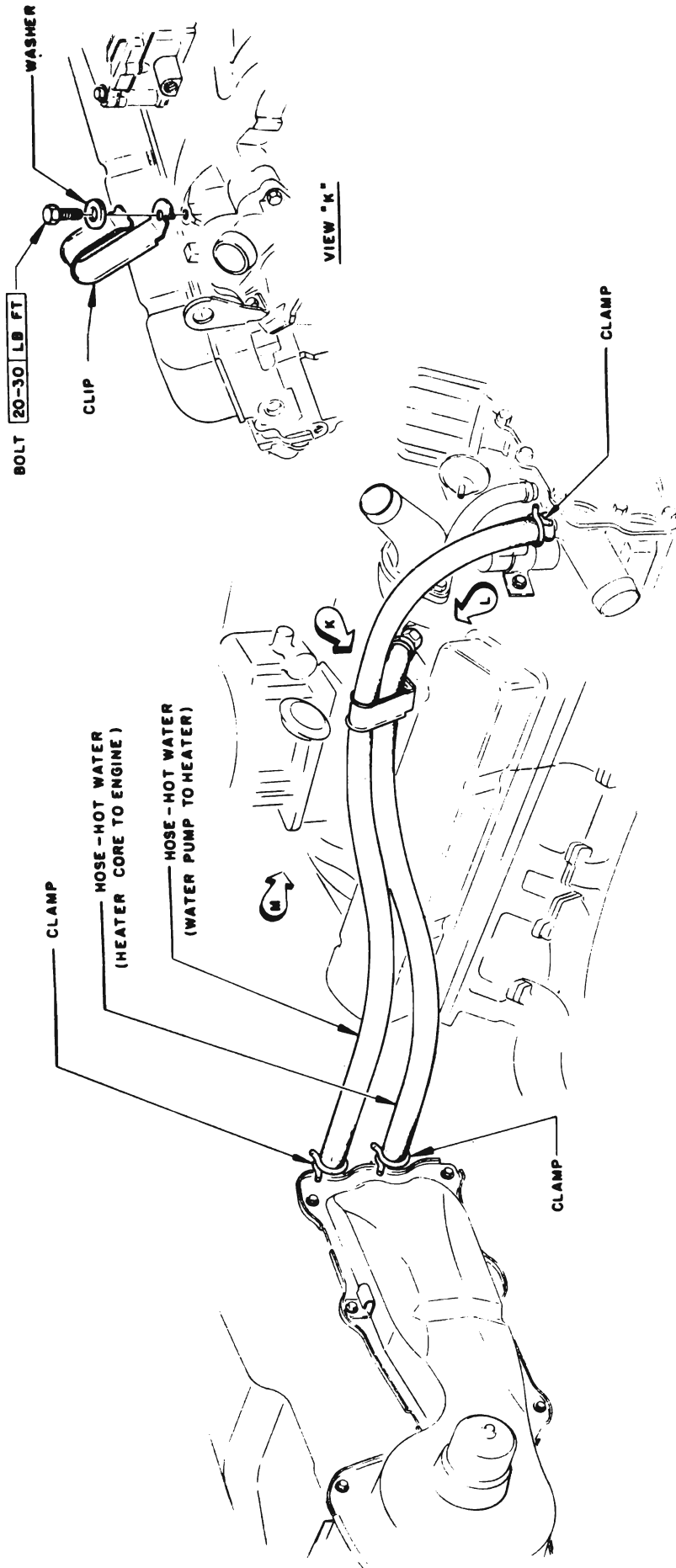

HEATER HOSE ASSEMBLY PRECAUTIONS

1. HOSE MUST BE PUSHED ON EACH CONNECTION AS FAR AS POSSIBLE.
2. HOSE CLAMP MUST BE INSTALLED STRAIGHT, AWAY FROM END OF HOSE, AND SLIGHTLY BEHIND CONNECTION.
3. NOT PERMISSIBLE TO USE ANY WETTING AGENTS TO ASSIST HOSE ASSEMBLY.
4. DO NOT OVERSPREAD SPRING TYPE CLAMPS DURING ASSEMBLY. USE PROPER TOOL WITH SPACERS.

12-29C

Figure 12-15 Heater Hose (Vacuum) Installation

12-12. A 25 amp fuse, located in the fuse block, is in series between the blower motor and the battery.

2. Heater Assembly - The heater assembly (see Figure 12-13) houses the heater core and the doors necessary to control mixing and channeling of the air. Air entering the heater assembly divides into two channels: (1) through the heater core and (2) through a by-pass around the heater core. The ratio of the mixture of heated to unheated air is controlled by the temperature door. An outside air inlet door initiates the air flow through the heater assembly. A defroster door controls the amount of air directed through the defroster outlets. The defroster door may be positioned to direct all air to the defroster outlet or all air to the floor outlet.

The heater core, located in the heater assembly, has water flowing through it at all times. The water flow begins at the front of the intake manifold and flows to the lower (inlet) port of the heater core, thru the heater core, out the upper (outlet) port of the heater core and to the suction port of the water pump. See Figure 12-14.

The heater assembly has fixed vane outlets to distribute air evenly throughout the passenger compartment.

3. Heater Control Assembly - The heater control assembly (see Figure 12-10) consists of three controls, namely the TEMPERATURE lever, outside air (SELECTOR) switch and FAN switch.

12-14 OPERATION OF CONTROLS

The TEMPERATURE lever is connected by a control wire to the temperature door on the heater assembly, and regulates the ratio of mixture between heated and unheated air, hence the temperature of the air. When the TEMPERATURE lever is positioned fully to the left, the temperature door is fully closed and prevents air flow through the heater core. When the TEMPERATURE lever is positioned midway in

its range of travel, the temperature door is moved in proportion to allow more outside air to flow through the heater core and hence be warmed. When the TEMPERATURE lever is positioned fully to the right, the temperature door is fully open and directs all outside air through the heater core.

The SELECTOR switch of the heater control assembly regulates the positioning of two doors: the outside air door and the defroster door. The SELECTOR switch has three positions: "OFF", "HTR" and "DEICE". Positioning of the SELECTOR switch to the "OFF" position closes the outside air door and the defroster door. When the outside air door is closed, all air is blocked from passing through the heater assembly. When the SELECTOR switch is moved to the "HTR" position, the outside air door is fully opened. Air is permitted to pass through the heater assembly and is directed to the floor of the car. Moving of the SELECTOR switch to "DEICE" position, opens the defroster door and directs the air to the defroster outlets.

The FAN switch operates a four position switch. A two resistor blower resistor assembly is connected in series between the blower motor and the switch, and serves to reduce the speed of the motor. When the FAN switch is positioned fully downward, the blower motor is "OFF". Movement of the switch upward provides "LO", "MED" and "HI" blower speeds.

DIVISION III

SERVICE PROCEDURES

12-15 REMOVAL AND INSTALLATION OF HEATER CONTROL ASSEMBLY

a. Removal

1. Disconnect lamp sockets, vacuum harness connector and blower switch connector from control assembly.

2. Loosen self-contained nuts on back of control assembly.

3. Slide control assembly back out of instrument panel and remove Bowden cable.

b. Installation

1. Install control assembly reverse of removal procedure.

2. Adjust TEMPERATURE control lever as necessary (Ref. paragraph 12-12).

12-16 REMOVAL AND INSTALLATION OF BLOWER MOTOR OR BLOWER MOTOR AND AIR INLET ASSEMBLY

a. Removal

1. Remove right front fender, refer to Group 110, paragraph 110-16.

2. (Blower Motor Only) Disconnect blower motor wire. Remove screws securing blower motor to air inlet assembly.

(Blower Motor and Air Inlet Assembly) Disconnect blower motor wire. Remove five nuts and two screws securing blower and air inlet assembly to dash. See Figure 12-11.

b. Installation

Install blower motor or blower motor and air inlet assembly reverse of removal procedures, and seal along mating surfaces between dash and air inlet assembly.

12-17 REMOVAL AND INSTALLATION OF HEATER ASSEMBLY OR HEATER CORE

a. Removal

1. Drain radiator and disconnect heater inlet and outlet hoses at dash. See Figure 12-15.

2. Disconnect vacuum hose from defroster door and outside air inlet door actuator diaphragms and control cable from temperature door lever.

3. Disconnect electrical connector from blower motor resistor.

4. Remove five nuts securing heater assembly to dash. See Figure 12-11.

5. Remove screw securing defroster outlet adapter to heater assembly

and raise adapter away from assembly.

6. Work heater assembly rearward until studs clear dash, and remove heater assembly.

b. Installation

1. Install heater assembly reverse of removal procedures and seal along mating surfaces between dash and

heater assembly.

2. Adjust temperature control cable as necessary (Ref. paragraph 12-12).

DIVISION IV

TROUBLE DIAGNOSIS

12-18 HEATER-DEFROSTER TROUBLE DIAGNOSIS

TROUBLE	CAUSE AND CORRECTION
Blower motor inoperative.	Check fuse. Check for defective heater blower switch. Check for defective blower resistor assembly. Check for loose connectors or broken wires.
Insufficient heating	Check operation of outside air door (paragraph 12-12), and temperature door (paragraph 12-13). Check for air leaks around sealing edges of components. Check for dirt in engine thermostat. Check for sufficient coolant. Check for dislodged diaphragm in flow control valve (46-48000 Series). Check for air leaks thru dash, around doors, windows, etc.
Inadequate defrosting	Check operation and adjustment of outside air door (paragraph 12-12), temperature door and/or defroster door. (paragraph 12-13). Check for air leaks and for sufficient coolant. Check for loose or disconnected defroster air hoses and for position of defroster duct and instrument panel openings. Twist tabs provide positive position if properly installed.
No air coming into car, but motor running.	Vacuum hose disconnected, or crossed Storage tank defective.