

# SECTION A

## SECTION A HEATER SYSTEM (43-44000 SERIES)

### CONTENTS

Division	Subject	Paragraph
I	SPECIFICATIONS AND ADJUSTMENTS:	
	General Specifications .....	12-1
	Adjustment of TEMPERATURE Selector Lever and Temperature Door..	12-2
	Adjustment of Outside Air (HEATER) Lever and Outside Air Door...	12-3
II	DESCRIPTION AND OPERATION:	
	Description of System.....	12-4
	Operation of Controls.....	12-5
III	SERVICE PROCEDURES:	
	Removal and Installation of Heater Control Assembly.....	12-6
	Removal and Installation of Blower Motor or Blower Motor and Air Inlet Assembly .....	12-7
	Removal and Installation of Heater Assembly or Heater Core.....	12-8
IV	TROUBLE DIAGNOSIS:	
	Heater-Defroster Trouble Diagnosis.....	12-9

### DIVISION I SPECIFICATIONS AND ADJUSTMENTS

#### 12-1 GENERAL SPECIFICATIONS

Recommended Coolant .....	Ethylene-glycol Base
Thermostat Opening Temperature	
L-6 .....	195°
V-8 (All) .....	190°
Cooling System Capacity with Heater (Quarts)	
L-6 .....	14.3
V-8 (350 cu. in.).....	16.5
V-8 (455 cu. in.).....	19.2
Blower Motor Type.....	12VDC
Blower Motor Fan.....	Squirrel Cage

12A-2

#### 12-2 ADJUSTMENT OF TEMPERATURE SELECTOR LEVER AND TEMPERATURE DOOR

*made before adjusting outside air (green) wire.*

The control cable should be adjusted when the recommended equal springback is not obtained at both ends of lever travel. This adjustment

should also be made when the heater assembly has been removed or when the temperature door does not open sufficiently to permit maximum air flow.

NOTE: This adjustment must be

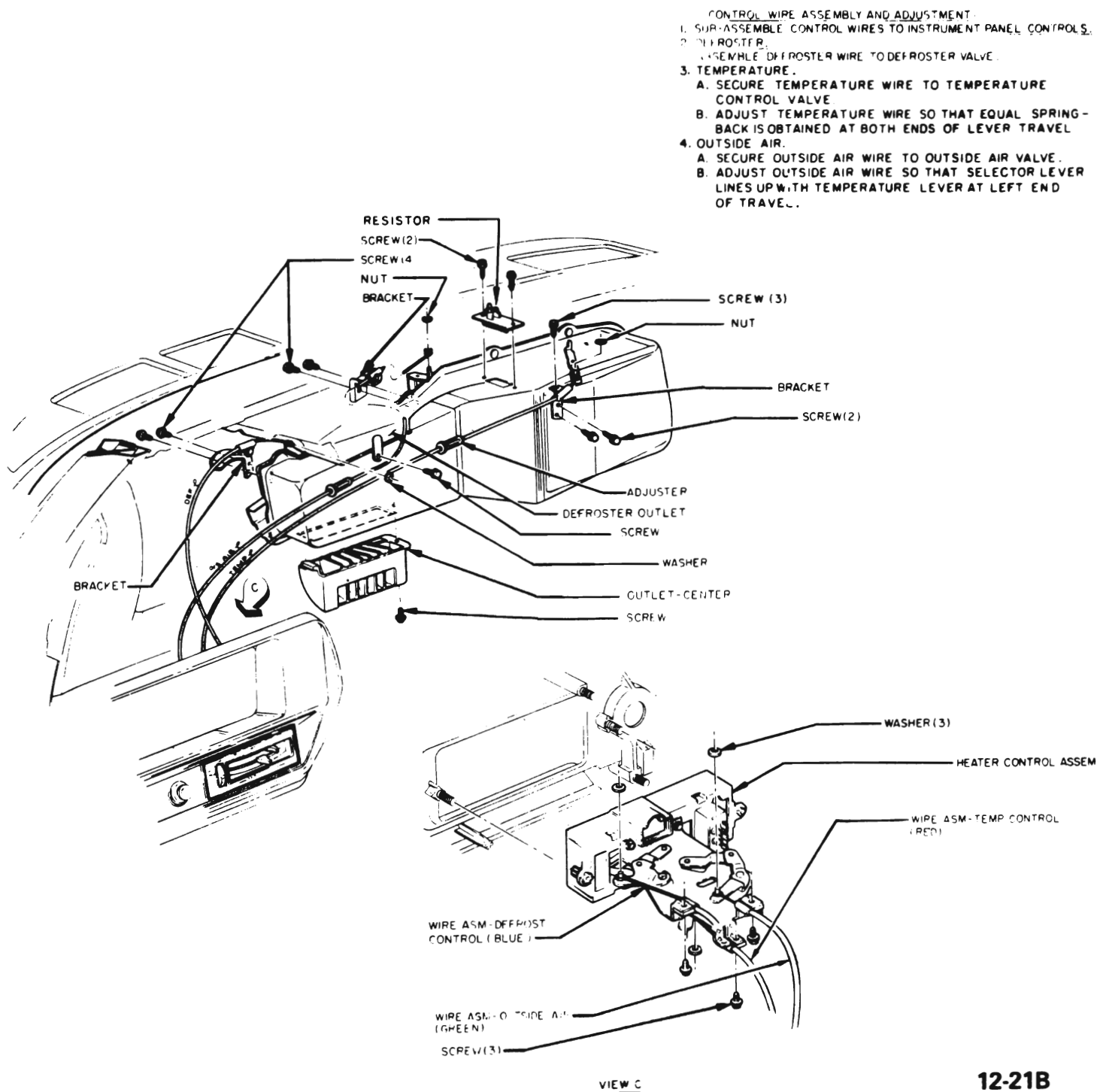

12-21B

Figure 12-1 Heater Control and Wire Installation

To adjust, position the TEMPERATURE lever to the "COOL" position and rotate the control cable adjuster nut until equal springback is obtained at both ends of lever travel. See Figure 12-1.

### 12-3 ADJUSTMENT OF OUTSIDE AIR (HEATER) LEVER AND OUTSIDE AIR DOOR

**NOTE:** The defroster control cable is a non-adjustable, fixed dimension

cable and regulates the defroster door to a predetermined travel.

The outside air control cable should be adjusted when the lever does not line-up with TEMPERATURE lever.

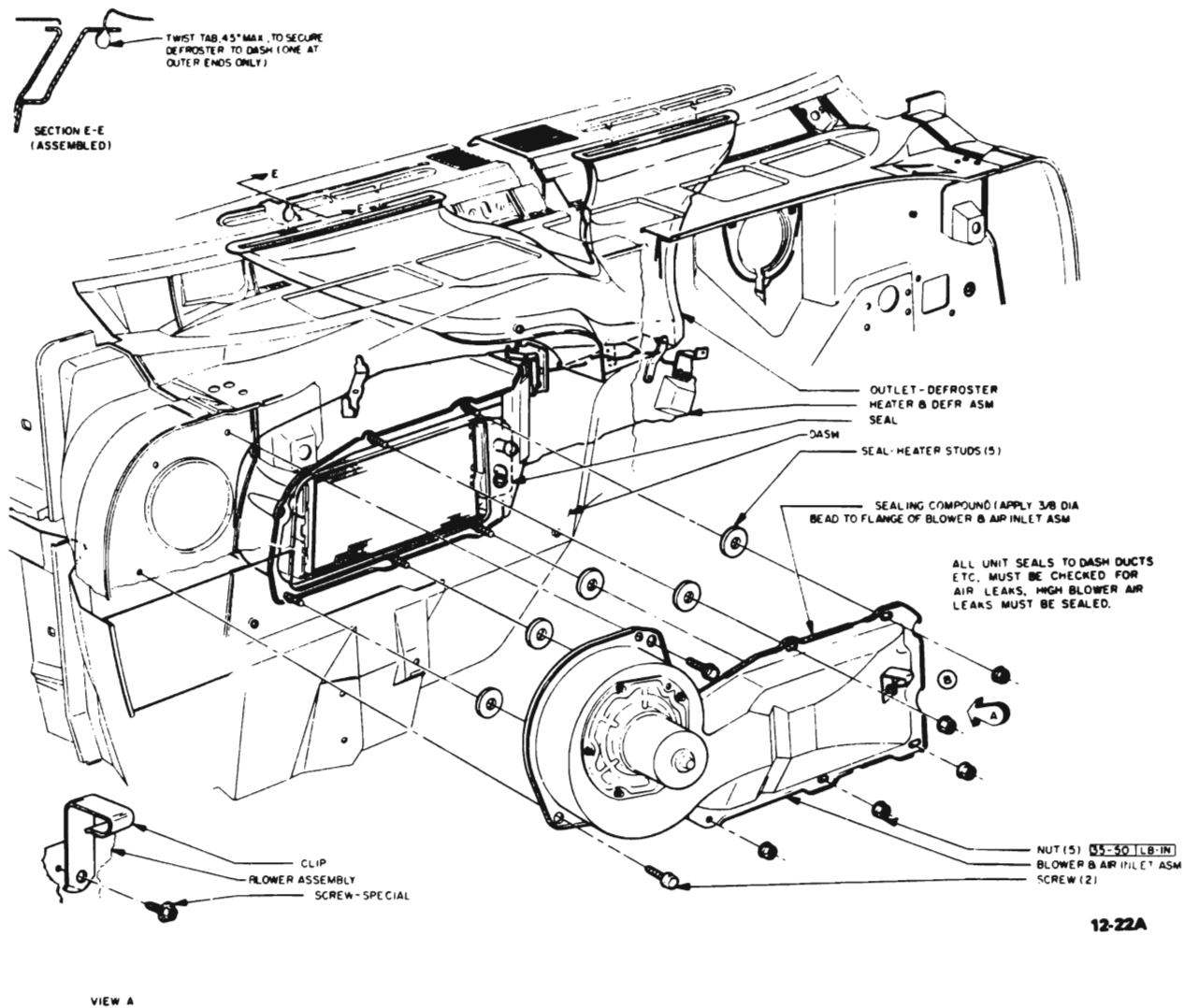

12-22A

Figure 12-2 Heater Installation

This adjustment should also be made when the heater assembly has been removed or when the outside air door does not open sufficiently to permit maximum air flow.

**NOTE:** The *TEMPERATURE* lever must be adjusted before *HEATER* lever adjustment.

To adjust, position the *TEMPERATURE* lever fully to the left, then position the *HEATER* lever to the "OFF" position and rotate the control cable adjuster nut until *HEATER* lever aligns with *TEMPERATURE* lever. See Figure 12-1.

**NOTE:** The *HEATER* control lever will lock in 'HEATER' position if outside air control cable is not properly adjusted.

## DIVISION II

### DESCRIPTION AND OPERATION

#### 12-4 DESCRIPTION OF SYSTEM

The heater system is an air mix type system in which outside air is heated and then mixed in varying amounts with cooler outside air to attain the desired air temperature. The system consists basically of three parts: (1) the blower and air inlet assembly, (2) the heater assembly and (3) the heater control assembly (see Figure 12-2). The operation of the system is as follows:

1. Blower and Air Inlet Assembly - The blower and air inlet assembly draws outside air through the outside air inlet grille located forward of the windshield reveal molding and channels the air into the heater assembly. The operation of the blower motor is controlled by the FAN switch on the heater control. The motor is connected in series with the four position FAN switch and also the blower resistor assembly. See Figure 12-3. A 25 amp fuse, located in the fuse block, is in series between the blower motor and the battery.

2. Heater Assembly - The heater assembly (see Figure 12-4) houses the heater core and the doors necessary to control mixing and channeling of the air. Air entering the heater assembly divides into two channels:

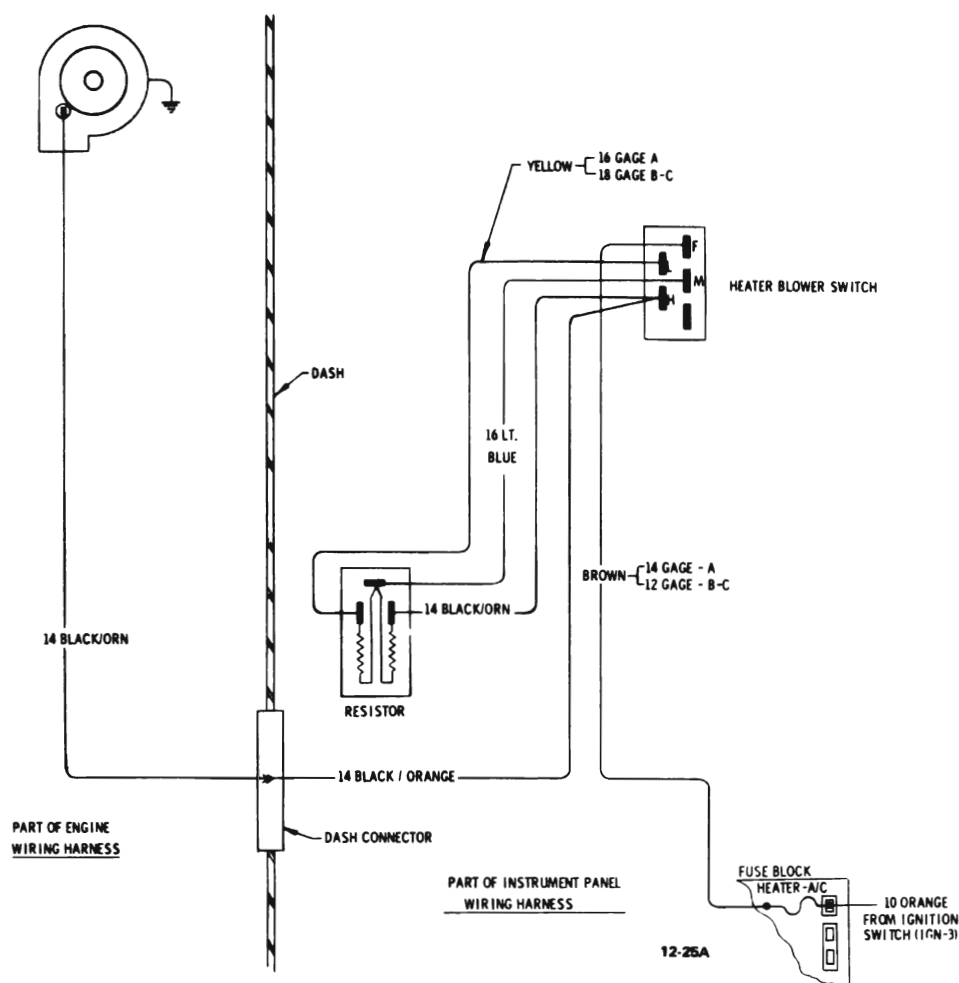

Figure I2-3 Heater System Wiring Diagram

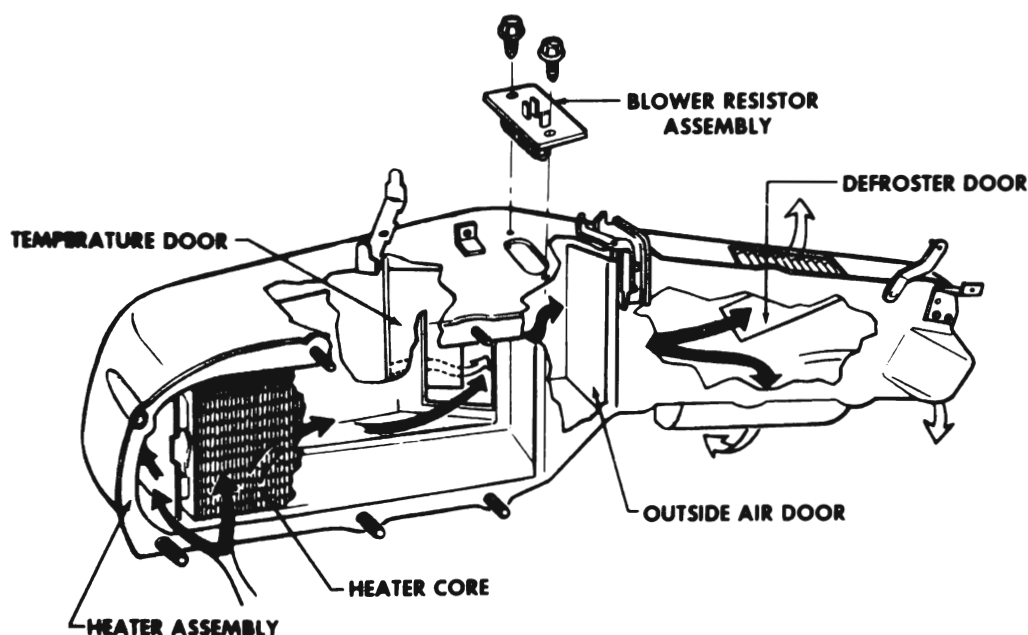

Figure I2-4 Heater System Air Flow

(1) through the heater core and (2) through a by-pass around the heater core. The ratio of the mixture of heated to unheated air is controlled by the temperature door. An outside air inlet door initiates the air flow through the heater assembly. A defroster door controls the amount of air directed through the defroster outlets. The defroster door may be positioned to direct all air to the defroster outlet, all air to the floor outlet, or to both the defroster and the floor outlets.

The heater core, located in the heater assembly, has water flowing through it at all times. The water flow begins at the front of the intake manifold (V- 8 engines) or thermostat housing (L-6 engines) and flows to the lower (inlet) port of the heater core, out the upper (outlet) port of the heater core and to the suction port of the water pump. See Figure I2-5.

The heater assembly has fixed vane outlets to distribute air evenly throughout the passenger compartment.

3. Heater Control Assembly - The heater control assembly (see Figure I2-1) consists of three controls, namely the TEMPERATURE lever, outside air-HEATER lever, and FAN switch.

## 12-5 OPERATION OF CONTROLS

The TEMPERATURE lever is connected by a control wire to the temperature door on the heater assembly, and regulates the ratio of mixture between heated and unheated air, hence the temperature of the air. The TEMPERATURE lever is positioned between "COOL" and "WARM" to control temperatures. When the temperature control is in the "COOL" position, the temperature door is fully closed and prevents air flow through the heater core. When the temperature control is positioned midway between "COOL" and "WARM", the outside air flow is split and approximately one half of the outside air flows through the heater core and one half of the



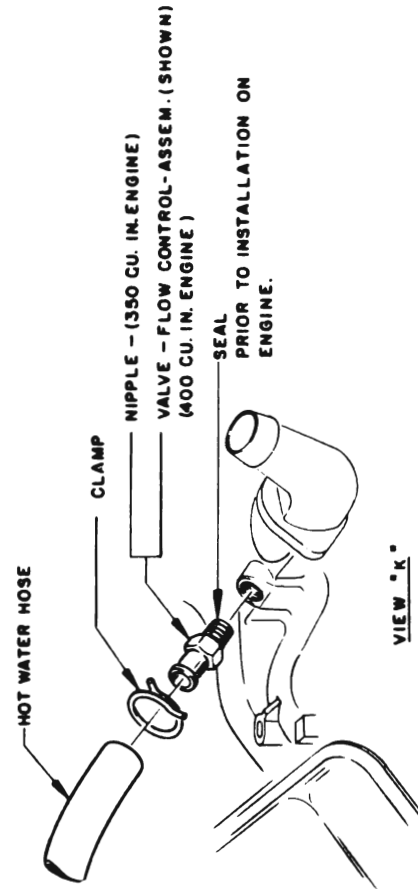
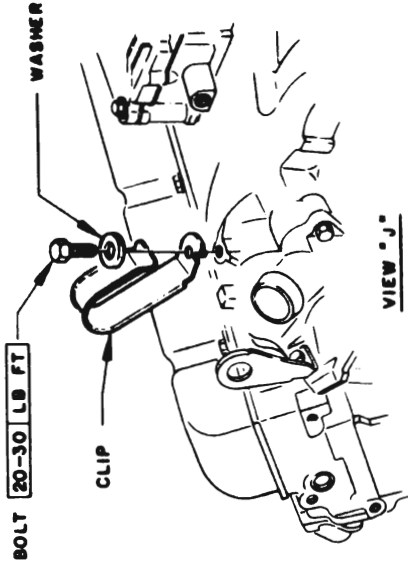
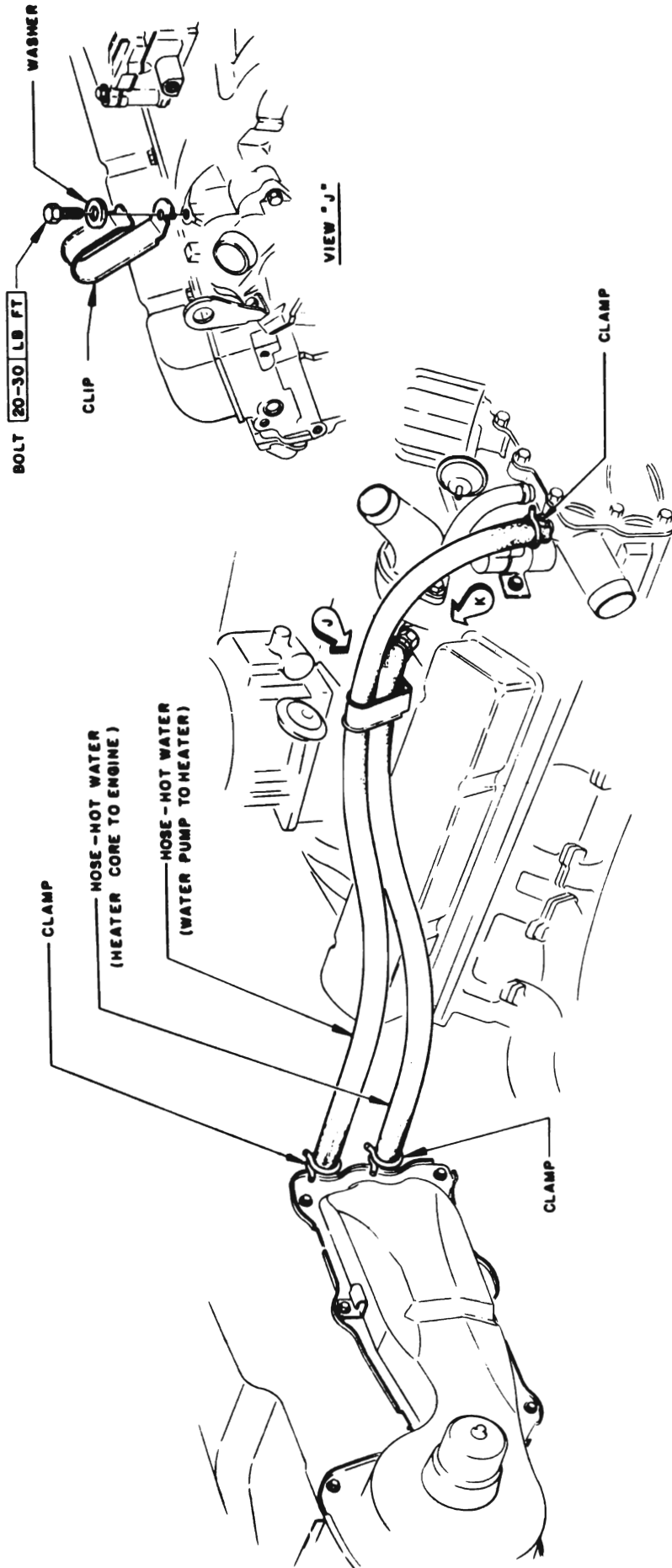

**HEATER HOSE ASSEMBLY PRECAUTIONS**

1. HOSE MUST BE PUSHED ON EACH CONNECTION AS FAR AS POSSIBLE.
  2. HOSE CLAMP MUST BE INSTALLED STRAIGHT, AWAY FROM END OF HOSE, AND SLIGHTLY BEHIND CONNECTION.
  3. NOT PERMISSIBLE TO USE ANY WETTING AGENTS TO ASSIST HOSE ASSEMBLY.
  4. DO NOT OVERSPREAD SPRING TYPE CLAMPS DURING ASSEMBLY. USE PROPER TOOL WITH SPACERS.
- SEE HEATER HOSE CHART FOR HOSE IDENTIFICATION.

**12-24C**

Figure 12-6 Heater Hose Installation (V-8)

outside air flows around and by-passes the heater core. When the temperature control is in the "WARM" position, the temperature door is fully open and prevents outside air from by-passing the heater core.

The HEATER lever of the heater control assembly regulates the positioning of two doors: the outside air door and the defroster door. Positioning of the HEATER lever to the "OFF" position closes the outside air door and the defroster door. When the outside air door is closed, all air is blocked from passing through the heater assembly. When the HEATER lever is moved to the "HEATER" position, the outside air door is fully opened. Air is permitted to pass through the heater assembly and is directed to the floor of the car. Moving of the HEATER lever to "DEICE" position, opens the defroster door and directs the air to the defroster outlets. Locating of the HEATER lever midway between "HEATER" and "DEICE" positions, causes the air to be routed to both the defroster outlets and the floor outlets proportional to lever setting.

The FAN switch operates a four position switch. A two resistor blower resistor assembly is connected in series between the blower motor and the switch, and serves to reduce the speed of the motor. When the FAN switch is positioned fully downward, the blower motor is "OFF". Movement of the switch upward provides "LO", "MED" and "HI" blower speeds.

## DIVISION III

### SERVICE PROCEDURES

#### 12-6 REMOVAL AND INSTALLATION OF HEATER CONTROL ASSEMBLY

##### a. Removal

1. Disconnect lamp sockets and blower switch connector from control assembly.
2. Loosen self-contained nuts on back of control assembly.
3. Slide control assembly back out of instrument panel and remove Bowden cables.

##### b. Installation

1. Install control assembly reverse of removal procedure.
2. Adjust HEATER and TEMPERATURE control levers as necessary (Ref. paragraphs 12-2 and 12-3).

#### 12-7 REMOVAL AND INSTALLATION OF BLOWER MOTOR OR BLOWER MOTOR AND AIR INLET ASSEMBLY

##### a. Removal

1. Remove right front fender skirt, refer to Group 110, paragraph 110-7.
2. (Blower Motor Only) Disconnect blower motor wire. Remove screws securing blower motor to air inlet assembly.
3. (Blower Motor and Air Inlet Assembly) Disconnect blower motor wire. Remove five nuts and two screws securing blower and air inlet assembly to dash. See Figure 12-2.

##### b. Installation

Install blower motor or blower motor and air inlet assembly reverse of removal procedures, and seal along mating surfaces between dash and air inlet assembly.

#### 12-8 REMOVAL AND INSTALLATION OF HEATER ASSEMBLY OR HEATER CORE

##### a. Removal

1. Remove right front fender skirt, refer to Group 110, paragraph 110-7.
2. Drain radiator.
3. Disconnect control cables from lever of defroster door and outside air inlet door on heater assembly. See Figure 12-1.
4. Disconnect temperature control cable from lever of temperature door on heater assembly.
5. Remove attaching nuts from heater assembly studs.
6. Disconnect heater inlet and outlet hoses from heater core inlet and outlet ports (see Figure 12-5).
7. Remove connector from blower motor resistor (see Figure 12-4).
8. Remove screws securing lower portion of defroster outlet assembly to top of heater assembly.
9. Work heater assembly rearward until studs clear dash, and remove heater assembly.

##### b. Installation

1. Install heater assembly reverse of removal procedures.
2. Adjust control cables as necessary (Ref. paragraph 12-2 and 12-3).

## DIVISION IV

### TROUBLE DIAGNOSIS

#### 12-9 HEATER-DEFROSTER TROUBLE DIAGNOSIS

**NOTE:** *It is suggested that prior to inspecting a car for heater system malfunctions, the owner be questioned to determine if system is being operated correctly. All windows and vents must be closed to effect maximum heat buildup.*

TROUBLE	CAUSE AND CORRECTION								
<p>Temperature of heater air at outlets too low</p> <table border="1" data-bbox="179 362 825 472"> <tr> <td>Outlet Air</td> <td>145</td> <td>150</td> <td>155</td> </tr> <tr> <td>Ambient Air</td> <td>0</td> <td>25</td> <td>40</td> </tr> </table>	Outlet Air	145	150	155	Ambient Air	0	25	40	<p>Check radiator cap for proper sealing action—replace if necessary.</p> <p>Check for proper engine coolant level. If level is down, correct cause of coolant loss and refill radiator.</p> <p>Check for dirt in engine thermostat.</p> <p>Inspect for kinks in heater or radiator hoses—relieve kink or replace hose.</p> <p>Check for dislodged diaphragm in flow control valve (400 cu. in. engine only).</p> <p>Check that TEMPERATURE lever operates temperature door full extent of travel—adjust as required.</p> <p>Heater core partially plugged due to sediment in cooling system—backflush heater core as necessary.</p>
Outlet Air	145	150	155						
Ambient Air	0	25	40						
<p>Temperature of heater air at outlets adequate—car will not build up sufficient heat</p>	<p>Check for body leaks such as: (1) floor side kick pad ventilators partially open, (2) leaking grommets in dash, (3) leaking welded seams along rocker panel and windshield, (4) leaks through access holes and screw holes, (5) leaking rubber molding around door and windows, (6) leaks between sealing edge of blower and air inlet assembly and dash, and between sealing edge of heater assembly and dash.</p>								
<p>Inadequate defrosting action</p>	<p>Check that DEFROST lever completely opens defroster door in DEICE position.</p> <p>Check that air lever completely opens defroster door in DEF position.</p> <p>Check for air leak in ducting between defroster outlet on heater assembly and defroster duct under instrument panel—seal area as necessary with body sealer.</p> <p>Check position of bottom of nozzle to heater. Locating tab provided.</p> <p>Insure that temperature and outside air doors open to full limit of travel.</p> <p>Check position of defroster nozzle openings relative to instrument panel openings. Twist tabs provide positive position if properly installed.</p>								
<p>Inadequate heated air circulated through car</p>	<p>Inspect floor carpet to insure that carpet lies flat under front seat and does not obstruct air flow under seat, and also inspect around outlet ducts to insure that carpet is well fastened to floor to prevent cupping of air flow—correct as necessary.</p> <p>Check heater air outlet for correct installation.</p>								
<p>Erratic heater operation</p>	<p>Partially plugged heater core—backflush heater core as necessary.</p> <p>Sediment in heater lines and radiator causing engine thermostat to stick open—flush system and clean or replace thermostat as necessary.</p> <p>Check for kinked heater hoses—relieve kinks or replace hose as necessary.</p> <p>Check coolant level.</p>								
<p>Hard operating or broken control wires</p>	<p>Check for loose wire tab screws or mis-adjusted wires—correct as required.</p> <p>Check for sticking heater system door(s) - lubricate as required using a silicone spray.</p>								
<p>Blower inoperative</p>	<p>Check fuse in fuse block and replace if necessary.</p> <p>Check wiring for open circuit—correct as necessary.</p> <p>Inspect for defective fan switch—replace as necessary.</p> <p>Check for defective blower motor—replace as necessary.</p> <p>Check blower resistor—replace if necessary.</p>								