

# SECTION A

## TURBO HYDRA-MATIC "400" AUTOMATIC TRANSMISSION

### CONTENTS

Division	Subject	Paragraph
I	SPECIFICATIONS AND ADJUSTMENTS: General Specifications . . . . . Bolt Torque Specifications . . . . . Idle Stator and Detent Switch Adjustments . . . . .	76-1 76-2 76-3
II	DESCRIPTION AND OPERATION: Description and Mechanical Operation . . . . . Hydraulic Operation . . . . . Functions of Valves and Hydraulic Control Units . . . . . Transmission Hydraulic Operation . . . . .	76-4 76-5 76-6 76-7
III	SERVICE PROCEDURES: Transmission Assembly-Removal and Installation . . . . . Removal of Converter and Vacuum Modulator . . . . . Removal of Governor, Speedometer Driven Gear, Oil Pan, and Filter . . . . . Removal of Valve Body Assembly, Governor Pipes and Detent Spring Assembly . . . . . Removal of Rear Servo, Solenoid, Connector, Valve Body Spacer Plate, Gasket, Front Servo, Manual Detent and Park Linkage . . . . . Removal of Rear Oil Seal and Extension Housing . . . . . Removal of Oil Pump, Forward Clutch, Direct Clutch, Intermediate Clutch and Gear Unit Assembly . . . . . Gear Unit Assembly . . . . . Governor Assembly . . . . . Front Servo Inspection . . . . . Rear Servo Assembly . . . . . Valve Body Assembly . . . . . Oil Pump Assembly . . . . . Forward Clutch Assembly . . . . . Direct Clutch and Intermediate Sprag . . . . . Center Support and Intermediate Clutch . . . . . Inspection of Transmission Parts . . . . . Assembly of Major Units . . . . . Rear Extension Housing . . . . . Installation of Manual Linkage . . . . . Installation of Check Balls, Front Servo, Gaskets, Spacer Plate and Solenoid Installation of Rear Servo Assembly . . . . . Installation of Valve Body Assembly and Governor Pipes . . . . . Installation of Oil Filter . . . . . Installation of Modulator Valve and Vacuum Modulator . . . . . Installation of Governor Assembly . . . . . Installation of Speedometer Driven Gear Assembly and Converter Assembly	76-8 76-9 76-10 76-11 76-12 76-13 76-14 76-15 76-16 76-17 76-18 76-19 76-20 76-21 76-22 76-23 76-24 76-25 76-26 76-27 76-28 76-29 76-30 76-31 76-32 76-33 76-34

## CONTENTS

Division	Subject	Paragraph
IV	TROUBLE DIAGNOSIS:	
	Sequence for Turbo Hydra-Matic "400" Transmission Diagnosis . . . . .	76-35
	Turbo Hydra-Matic "400" Transmission Oil Checking Procedures . . . . .	76-36
	External Oil Leaks . . . . .	76-37
	Turbo Hydra-Matic "400" Transmission Trouble Diagnosis Chart . . . . .	76-38
	Vacuum Modulator Diagnosis . . . . .	76-39
	Turbo Hydra-Matic "400" Transmission Oil Pressure Checks . . . . .	76-40

## DIVISION I SPECIFICATIONS AND ADJUSTMENTS

## 76-1 GENERAL SPECIFICATIONS

## a. Model Designations

Trans. Model	Engine Cu. In. Displacement	Forward Clutch		Direct Clutch		Intermediate Clutch		Forward Clutch Piston	Direct Clutch Piston	Intermediate Clutch Piston	Modulator Can Assembly	Model Use
		Steel Plate Req'd.	Composition Plate Req'd.	Steel Plate Req'd.	Composition Plate Req'd.	Steel Plate Req'd.	Composition Plate Req'd.					
BT	430	5	5	5	5	3	3	8624016	8625514	8624210	8623947	Riviera
BA	400	5	5	5	5	3	3	8624016	8625514	8624210	8623947	G.S. 400
BW	400	5	5	5	5	3	3	8624016	8625514	8624210	8623947	Sport-wagon 400
BU	350	5	5	5	5	3	3	8624016	8625514	8624210	8623947	LeSabre 400
BC	430	5	5	5	5	3	3	8624016	8625514	8624210	8623947	Wildcat-Electra
BB	400	5	5	5	5	3	3	8624016	8625514	8624210	8623947	G.S. 400

## 76-2 BOLT TORQUE SPECIFICATIONS

Location	Thread Size	Torque Lbs. Ft.
Solenoid Assembly to Case . . . . .	1/4-20	8
Valve Body to Case . . . . .	1/4-20	8
Pump Body to Cover . . . . .	5/16-18	18
Pump Assembly to Case . . . . .	5/16-18	18
Rear Servo Cover to Case . . . . .	5/16-18	18
Governor Cover to Case . . . . .	5/16-18	18
Parking Brake Bracket to Case . . . . .	5/16-18	18
Vacuum Modulator Retainer to Case . . . . .	5/16-18	18
Valve Body to Case . . . . .	5/16-18	8
Oil Pan to Case . . . . .	5/16-18	12
Case Extension to Case . . . . .	3/8-16	23
Oil Filter to Valve Body . . . . .	1/4-20	10

**b. Transmission Identification Number**

A production identification number is stamped on a metal tag, located in the lower right side of the transmission case.

The production code number is located along the top of the tag. Since the production code number furnishes the key to construction and interchangeability of parts in each transmission, the number should be used when selecting replacement parts as listed in the master parts list. The number should always be furnished on product reports, *AFA forms*, and all correspondence with the factory concerning a particular transmission.

On all 1969 Super Turbine 400 transmission the car serial number is stamped on a pad located just above the bottom pan face on the left hand side of the transmission.

**c. Turbo Hydra-matic 400 Fluid Recommendations**

Use DEXRON Automatic Transmission Fluid *only* in all 1969 model Turbo Hydra-matic 400 automatic transmissions (GM Part No. 1050568-69-70 or other fluid having DEXRON identifications).

DEXRON is an especially formulated automatic transmission fluid designed to improve transmission operation.

**NOTE:** Use DEXRON or type "A" automatic transmission fluid identified by the mark "AQ-ATF" followed by a number and the suffix letter "A" (AQ-ATF-XXXX-A) in all automatic transmissions prior to the 1968 models.

The oil pan should be drained and the filter replaced every 24,000 miles and fresh fluid added to obtain the proper level on the dipstick. See sub-paragraph 2 for proper refill procedures. For cars subjected to heavy city traffic during hot weather, or in commercial use, when the engine is regularly idled for prolonged periods, the oil pan

should be drained and the filter replaced every 12,000 miles.

**1. Checking and Adding Fluid**

Fluid level should be checked at every engine oil change. The "FULL" and "ADD" marks on the transmission dipstick indicate one pint difference.

To determine proper fluid level, proceed as follows:

**CAUTION:** The full mark on the dipstick is an indication of transmission fluid at normal operating temperature of 180°F. This temperature is only obtained after at least 15 miles of expressway driving or equivalent of city driving.

1. With manual control lever in Park position start engine. DO NOT RACE ENGINE. Move manual control lever through each range.

2. Immediately check fluid level with selector lever in Park, engine running, and vehicle on LEVEL surface.

At this point, when a reading is made, fluid level on the dipstick should be at the "FULL" mark.

3. If additional fluid is required, add fluid to the "FULL" mark on the dipstick.

If vehicle can not be driven 15 expressway miles or equivalent, and it becomes necessary to check fluid level, the transmission fluid must be at room temperature (70°F).

With fluid at room temperature (70°F) follow steps 1, 2, and 3 below.

1. With manual control lever in Park position start engine. DO NOT RACE ENGINE. Move manual control lever through each range.

2. Immediately check fluid level with selector lever in Park, engine running, and vehicle on LEVEL surface.

At this point, when a reading is made, fluid level on the dipstick

should be 1/4" below the "ADD" mark.

3. If additional fluid is required add fluid to bring level to 1/4" below the "ADD" mark on the dipstick.

**CAUTION:** Do not Overfill, as foaming and loss of fluid through the vent pipe might occur as fluid heats up. If fluid is too low, especially when cold, complete loss of drive may result which can cause transmission failure.

**NOTE:** If transmission fluid level is correctly established at 70°F it will appear at the "FULL" mark on the dipstick when the transmission reaches normal operating temperature (180°F). The fluid level is set 1/4" below the "ADD" mark on the dipstick to allow for expansion of the fluid which occurs as transmission temperatures rise to normal operating temperature of 180°F.

**2. Draining Oil Pan and Replacing Filter**

(a) Raise car on hoist or place on jack stands, and provide container to collect draining fluid.

(b) Remove oil pan and gasket. Discard gasket.

(c) Drain fluid from oil pan. Clean pan with solvent and dry thoroughly with clean compressed air.

(d) Remove oil filter retainer bolt, oil filter, intake pipe assembly and intake pipe to case "O" ring. Discard the filter and intake pipe to case "O" ring.

(e) Install new "O" ring seal on intake pipe and place pipe assembly into grommet on new filter assembly. With new "O" ring on intake pipe, install pipe and filter assembly into case, attaching filter to valve body assembly with retainer bolt. Torque to 10 lb.ft.

(f) Install new gasket on oil pan and install pan. Tighten attaching bolts to 12 lb.ft.

(g) Lower car and add 5 pints of

transmission fluid through filler tube.

(h) With manual control lever in Park position, start engine. **DO NOT RACE ENGINE.** Move manual control lever through each range.

(i) Immediately check fluid level with selector lever in Park, engine running, and vehicle on LEVEL surface.

(j) Add additional fluid to bring level to 1/4" below the "ADD" mark on the dipstick.

**NOTE: The fluid level is set 1/4" below the "ADD" mark on the dipstick to allow for expansion of the fluid which occurs as transmission temperatures rise to normal operating temperature.**

**CAUTION: Do not overfill.**

### 3. Adding Fluid to Fill Dry Transmission and Converter Assembly

The fluid capacity of the Turbo Hydra-matic 400 transmission and converter assembly is approximately 23 pints, but correct level is determined by the mark on the dipstick rather than by amount added. In cases of transmission overhaul, when a complete fill is required, including a new converter proceed as follows:

**NOTE: The converter should be replaced only if the converter itself fails. On any major failure, such as a clutch or gearset, the filter must be replaced.**

(a) Add 10 pints of transmission fluid through filler tube.

**NOTE: If installation of a new converter is not required add only 6 pints of transmission fluid.**

(b) With manual control lever in Park position start engine and place fast idle screw on middle of fast idle cam. **DO NOT RACE ENGINE.** Move manual control lever through each range.

(c) Immediately check fluid level with selector lever in Park, engine running, and vehicle on LEVEL surface.

(d) Add additional fluid to bring level to 1/4" below the "ADD" mark on the dipstick.

**NOTE: Fluid level is set at 1/4" below the "ADD" mark on the dipstick to allow for expansion as fluid heats up.**

**CAUTION: Do not overfill.**

#### d. Turbo Hydra-matic 400 Towing Instructions

If a Buick equipped with Turbo

Hydra-matic 400 transmission must be towed, the following precautions must be observed: The car may be towed safely on its rear wheels with the shift lever in neutral position at speeds of 35 miles per hour or less under most conditions.

However, the drive shaft must be disconnected or the car towed on its front wheels if:

Tow speeds in excess of 35 mph are necessary,

Car must be towed for extended distances (over 50 miles) or,

Transmission is not operating properly.

If car is towed on its front wheels, the steering wheel should be secured to keep the front wheels in a straight-ahead position.

#### e. Rocking Car

If it becomes necessary to rock the car to free it from sand, mud or snow, move the selector lever from "D" to "R" in a repeat pattern while simultaneously applying moderate pressure to the accelerator. Do not race engine. Avoid spinning wheels when trying to free the car.

### 76-3 DETENT SWITCH ADJUSTMENT

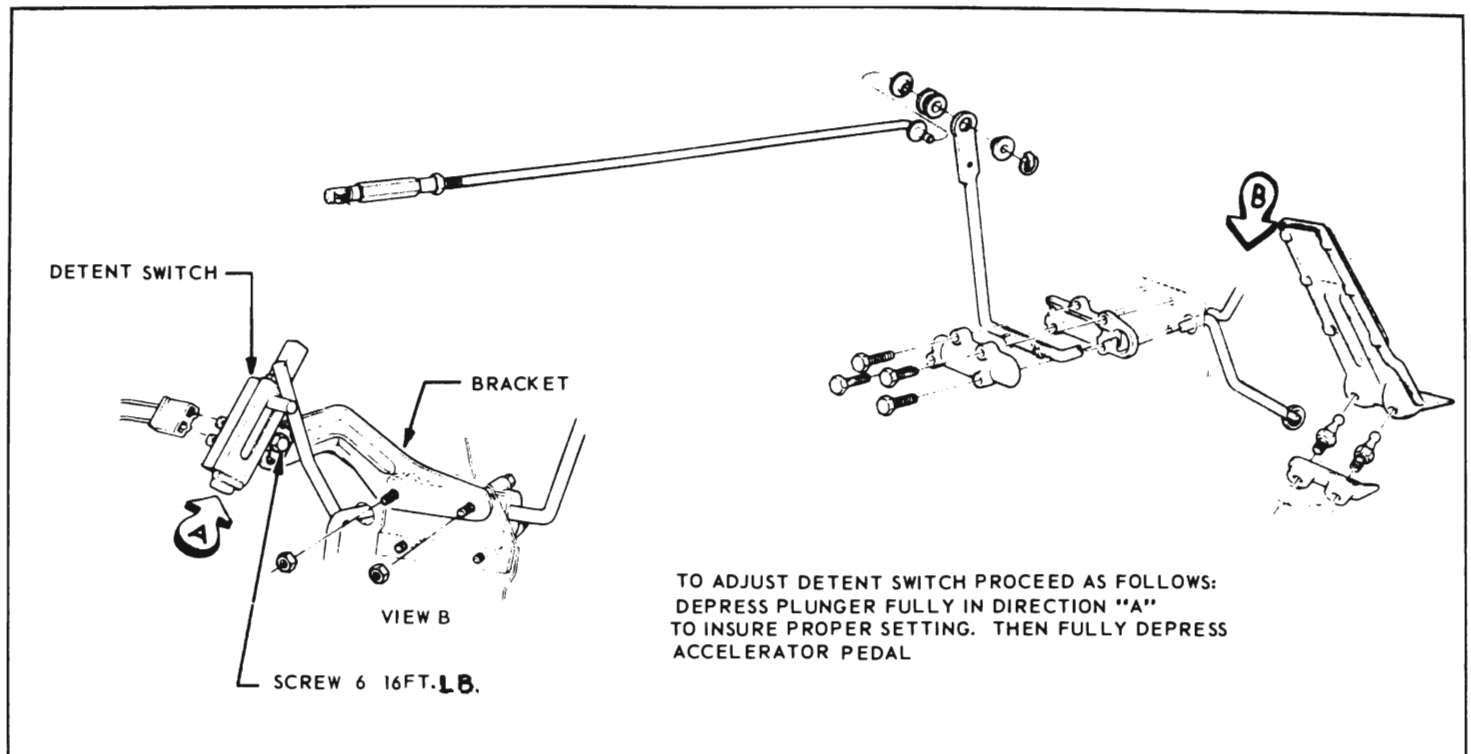

Figure 76-201 - Detent Switch Adjustment

## DIVISION II

### DESCRIPTION AND OPERATION

#### 76-4 DESCRIPTION

The Turbo Hydra-matic 400 Automatic Transmission, see Figure 76-202, is a fully automatic unit consisting primarily of a 3-element hydraulic torque converter and a compound planetary gear set. Three multiple-disc clutches, one (1) one way roller clutch, one (1) one way sprag clutch and two bands provide the friction elements required to obtain the desired function of the compound planetary gear set.

The 3-element torque converter consists of a pump, turbine and a stator assembly. The stator is mounted on a one way roller clutch which will allow the stator to turn clockwise but not counterclockwise.

The torque converter housing is filled with oil and is attached to the

engine crankshaft by a flywheel, thus always rotates at engine speed. The converter pump is an integral part of the converter housing, therefore the pump blades, rotating at engine speed set the oil within the converter into motion and direct it to the turbine, causing the turbine to rotate.

As the oil passes through the turbine it is traveling in such a direction that if it were not *redirected* by the stator it would hit the rear of the converter pump blades and impede its pumping action. So at low turbine speeds, the oil is redirected by the stator to the converter pump in such a manner that it actually assists the converter pump to deliver power, or multiply engine torque.

As turbine speed increases, the direction of the oil leaving the turbine changes and flows against the rear side of the stator vanes in a clockwise direction. Since the stator is now impeding the smooth flow of oil, its roller clutch releases and it revolves freely on its shaft. Once the

stator becomes inactive, there is no further multiplication of engine torque within the converter. At this point, the converter is merely acting as a fluid coupling as both the converter pump and turbine are being driven at approximately the same speed - or at a one-to-one ratio.

A hydraulic system, pressurized by a gear type pump, provides the working pressure required to operate the friction elements and automatic controls.

External control connections to transmission are:

Manual Linkage - To select the desired operating range.

Engine Vacuum - To operate a vacuum modulator unit.

12 Volt Electrical Signal - To operate an electrical detent solenoid.

A vacuum modulator is used to automatically sense any change in

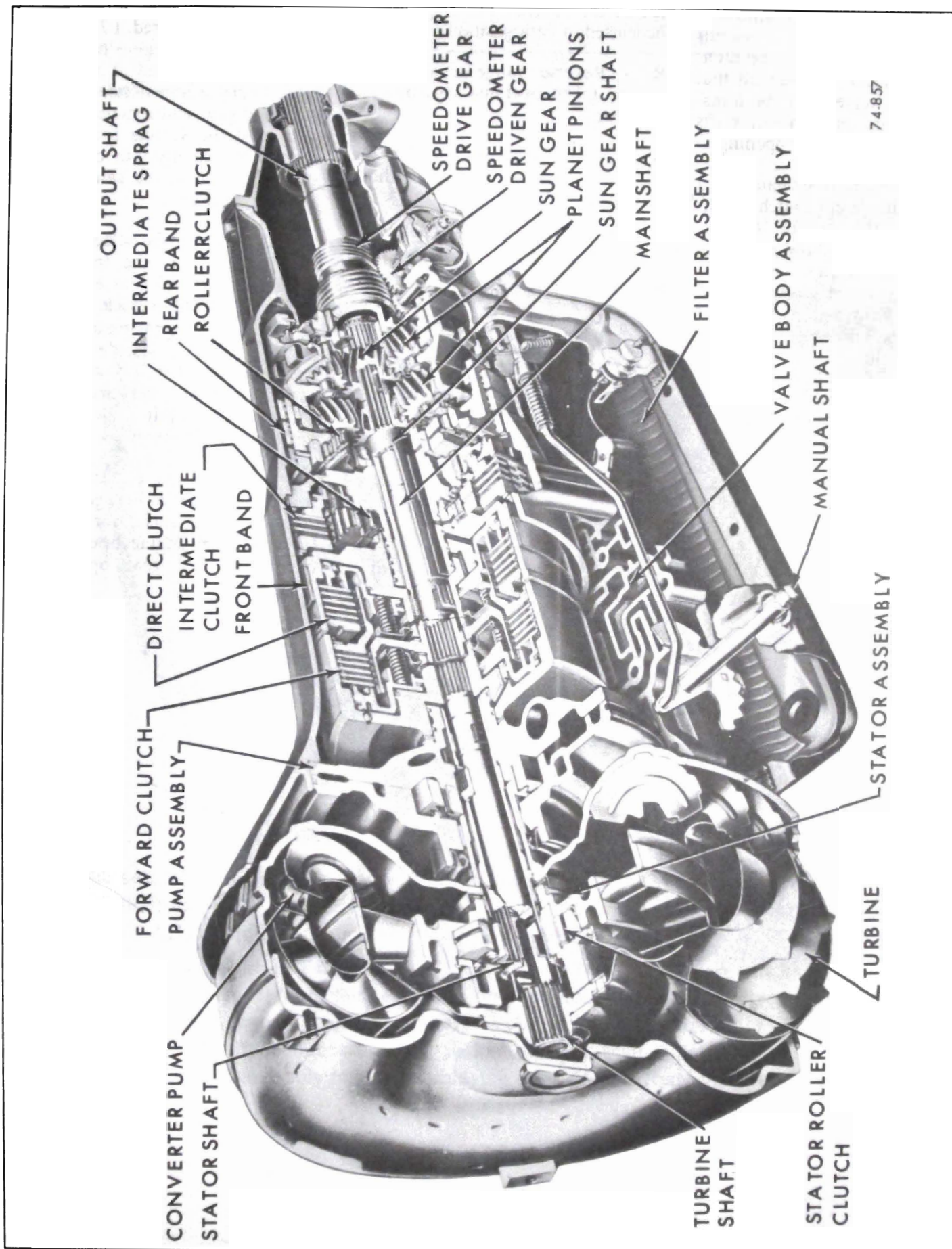

Figure 76-202 - Cross Section of Transmission

the torque input to the transmission. The vacuum modulator transmits this signal to the pressure regulator, which controls line pressure, so that all torque requirements of the transmission are met and smooth shifts are obtained at all throttle openings.

The detent solenoid is activated by a signal from the detent switch that is connected to the throttle linkage. When the throttle is fully open, the switch on the linkage is closed, energizing the detent solenoid and causing the transmission to downshift at speeds below approximately 70 MPH

The selector quadrant has six selector positions: P, R, N, D, L2, L1.

**P.** - Park position positively locks the output shaft to the transmission case by means of a locking pawl to prevent the vehicle from rolling either direction. This position should be selected whenever the driver

leaves the vehicle. The engine may be started in Park position.

**R.** - Reverse range enables the vehicle to be operated in a reverse direction.

**N.** - Neutral position enables the engine to be started and run without driving the vehicle.

**D.** - Drive range is used for all normal driving conditions and maximum economy.

Drive range has three gear ratios, from the starting ratio to direct drive. Detent downshift is available for safe passing by depressing the accelerator to the floor.

**L2** - L2 range adds new performance for congested traffic or hilly terrain. L2 range has the same starting ratio as drive range, but prevents the transmission from shifting above second gear to retain

second gear acceleration when extra performance is desired. L2 range can also be used for engine braking. L2 range can be selected at any vehicle speed, and the transmission will shift to second gear and remain in second gear until the vehicle speed or the throttle are changed to obtain first gear operation in the same manner as in drive range.

**L1** - L1 range can be selected at any vehicle speed and the transmission will shift to second gear and remain in second until vehicle speed is reduced to approximately 30-40 MPH, depending on axle ratio. The transmission will then downshift into first gear. Under no circumstances will it again upshift while the selector lever is in L1 range.

L1 range prevents the transmission from shifting out of first gear. This is particularly beneficial for maintaining maximum engine braking when continuous first gear operation is desirable.

## 76-5 MECHANICAL OPERATION

## a. Operation of Components in Drive Range – First Gear

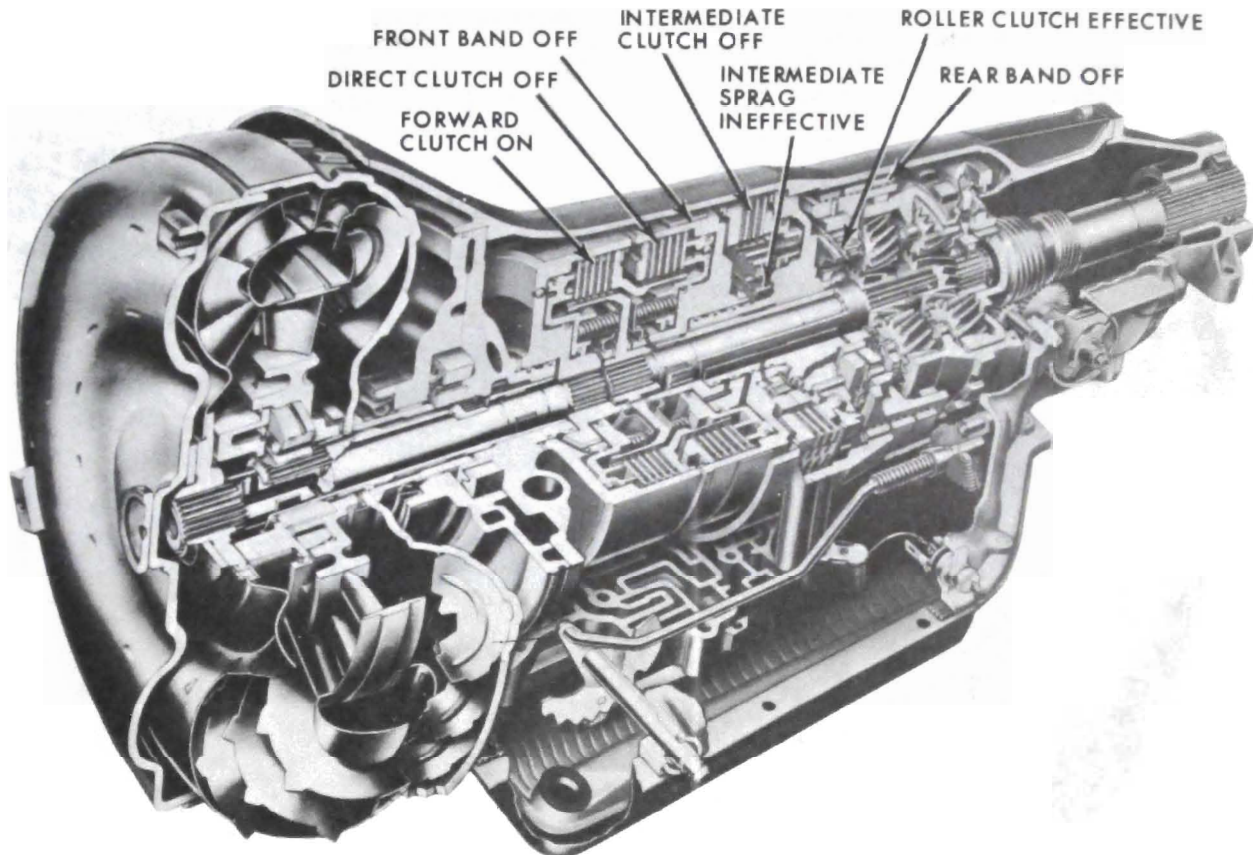

With the selector lever in Drive Range, the forward clutch is applied. This delivers turbine torque to the mainshaft and turns the rear internal gear in a clockwise direction. (Converter torque ratio = approximately 2.:1. at stall).

Clockwise motion of the rear internal gear causes the rear pinions to turn clockwise to drive the sun gear counterclockwise. In turn, the sun gear drives the front pinions clockwise, thus turning the front internal gear, output carrier, and output shaft clockwise in a reduction ratio of approximately 2.5:1. The reaction of the front pinions against the front internal gear is taken by the reaction carrier and one-way roller clutch assembly to the transmission case. (Approximate stall ratio = 5.:1.)

74-864A

Figure 76-203 · Drive Range · First Gear



## b. Operation of Components in Drive Range – Second Gear

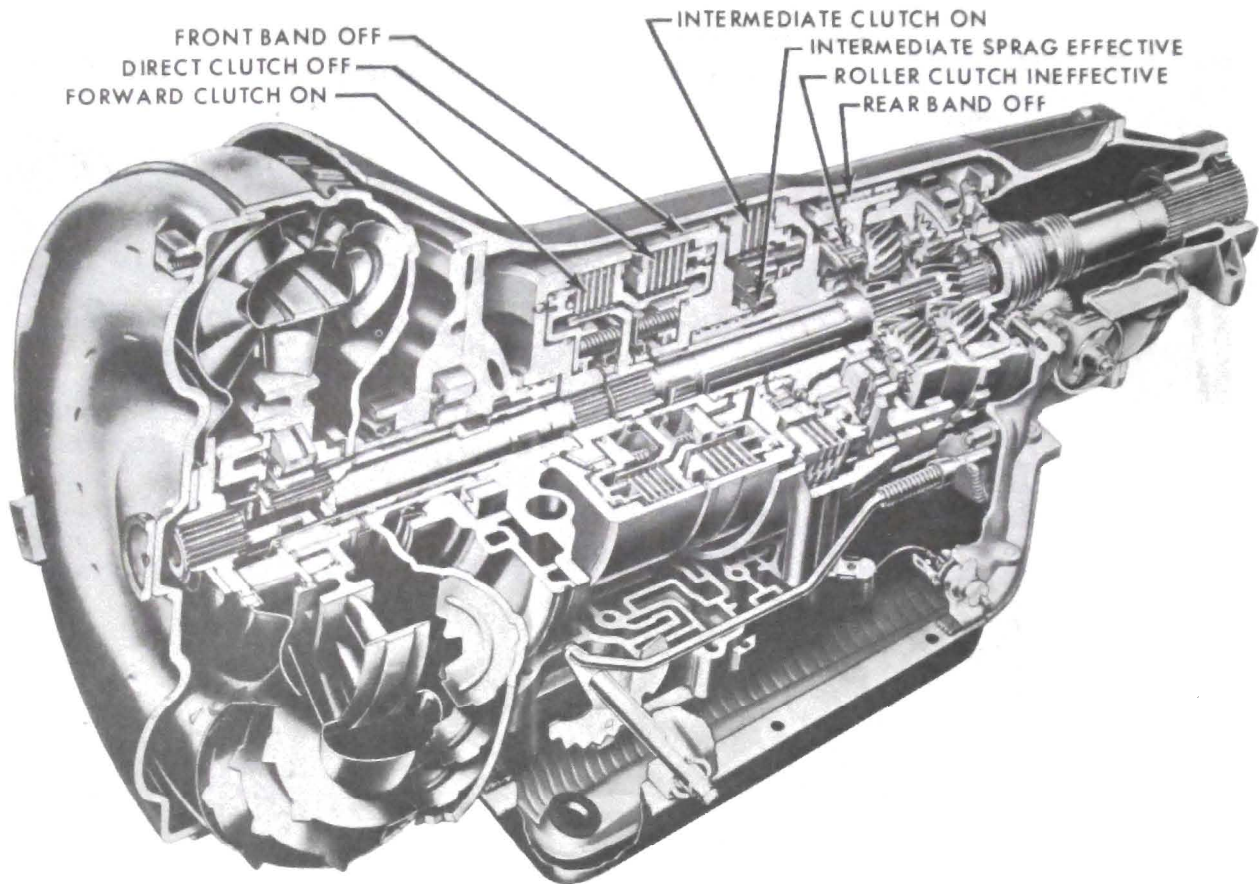

In second gear, the intermediate clutch is applied to allow the intermediate sprag to hold the sun gear against counterclockwise rotation. Turbine torque through the forward clutch is now applied through the mainshaft to the rear internal gear in a clockwise direction.

Clockwise rotation of the rear internal gear turns the rear pinions clockwise against the stationary sun gear. This causes the output carrier and output shaft to turn clockwise in a reduction ratio of approximately 1.5:1.

74-865A

Figure 76-204 · Drive Range ·  
Second Gear

### C. Operation of Components in Drive Range – Third Gear

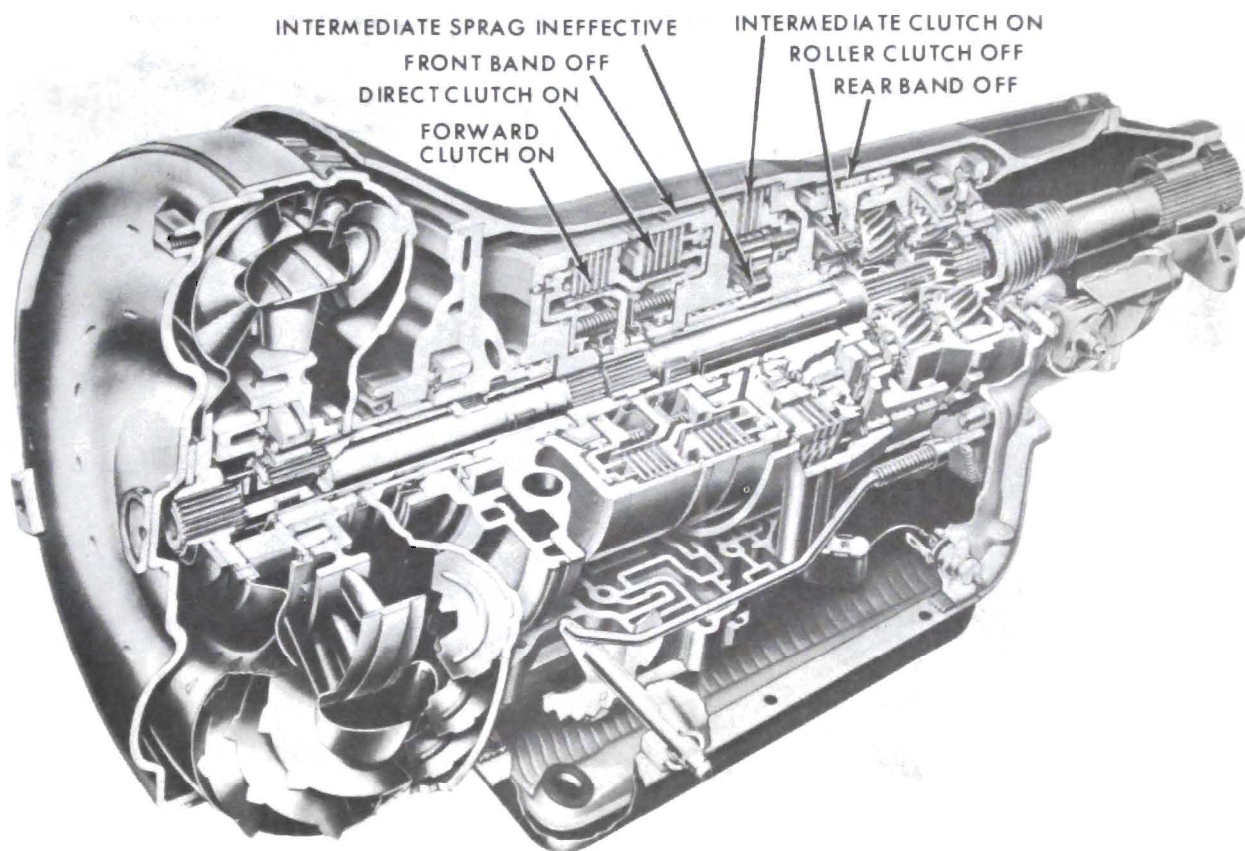

In direct drive, engine torque is transmitted to the converter through the forward clutch to the mainshaft and rear internal gear. Because the direct clutch is applied, equal power is also transmitted to the sun gear shaft and the sun gear. Since both the sun gear and internal gears are now turning at the same speed, the planetary gear set is essentially locked and turns as one unit in direct drive or a ratio of 1:1.

74-866A

Figure 74-205 - Drive Range -  
Third Gear

d. Operation of Components in Low - L<sup>2</sup> Range - Second Gear

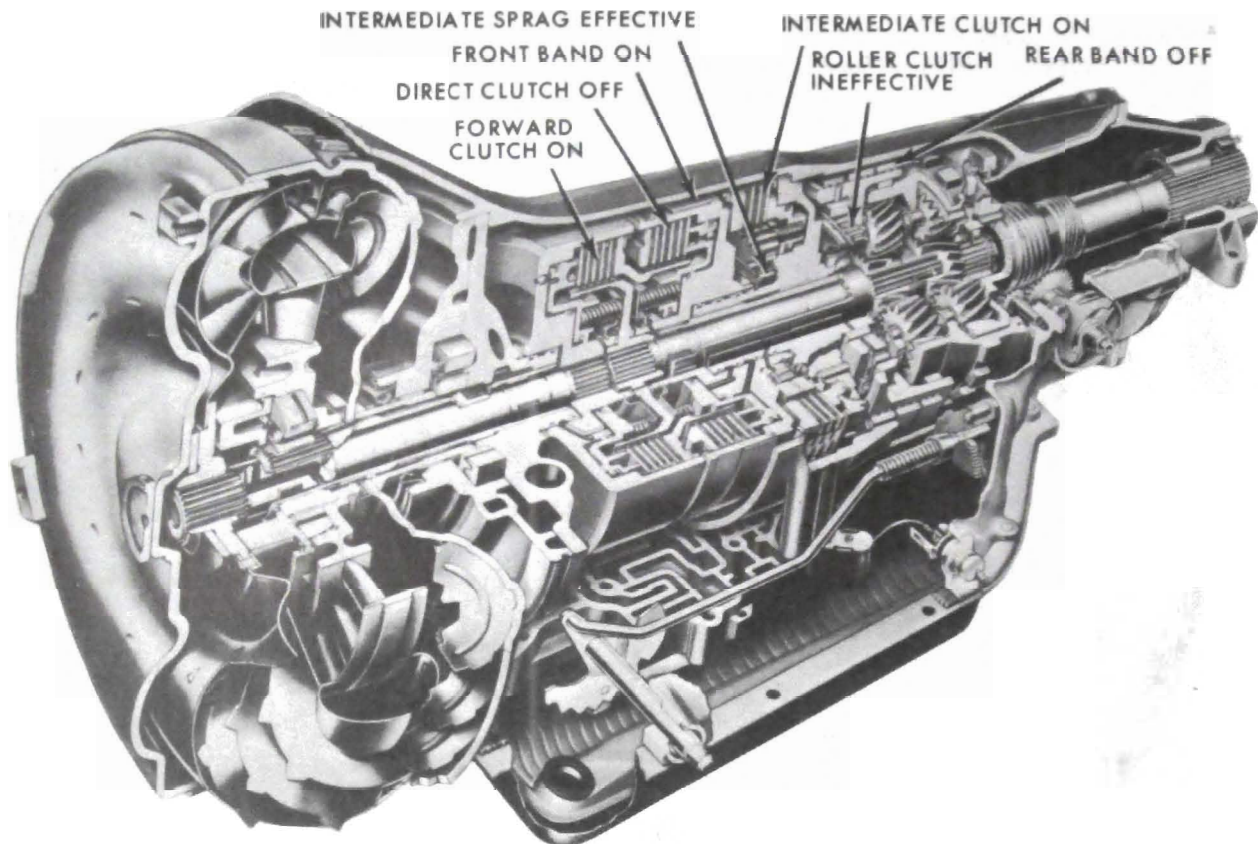

In second gear, the intermediate clutch is applied to allow the intermediate sprag to hold the sun gear against counterclockwise rotation. Turbine torque through the forward clutch is now applied through the mainshaft to the rear internal gear in a clockwise direction.

Clockwise rotation of the rear internal gear turns the rear pinions clockwise against the stationary sun gear. This causes the output carrier and output shaft to turn clockwise in a reduction ratio of approximately 1.5:1.

In L<sup>2</sup> Range second gear, overrun braking is provided by the front band as it holds the sun gear fixed. Without the band applied, the sun gear would overrun the intermediate sprag.

74-867A

Figure 74-206 - L2 Range - Second Gear

e. Operation of Components in Low – L<sup>1</sup> Range – First Gear

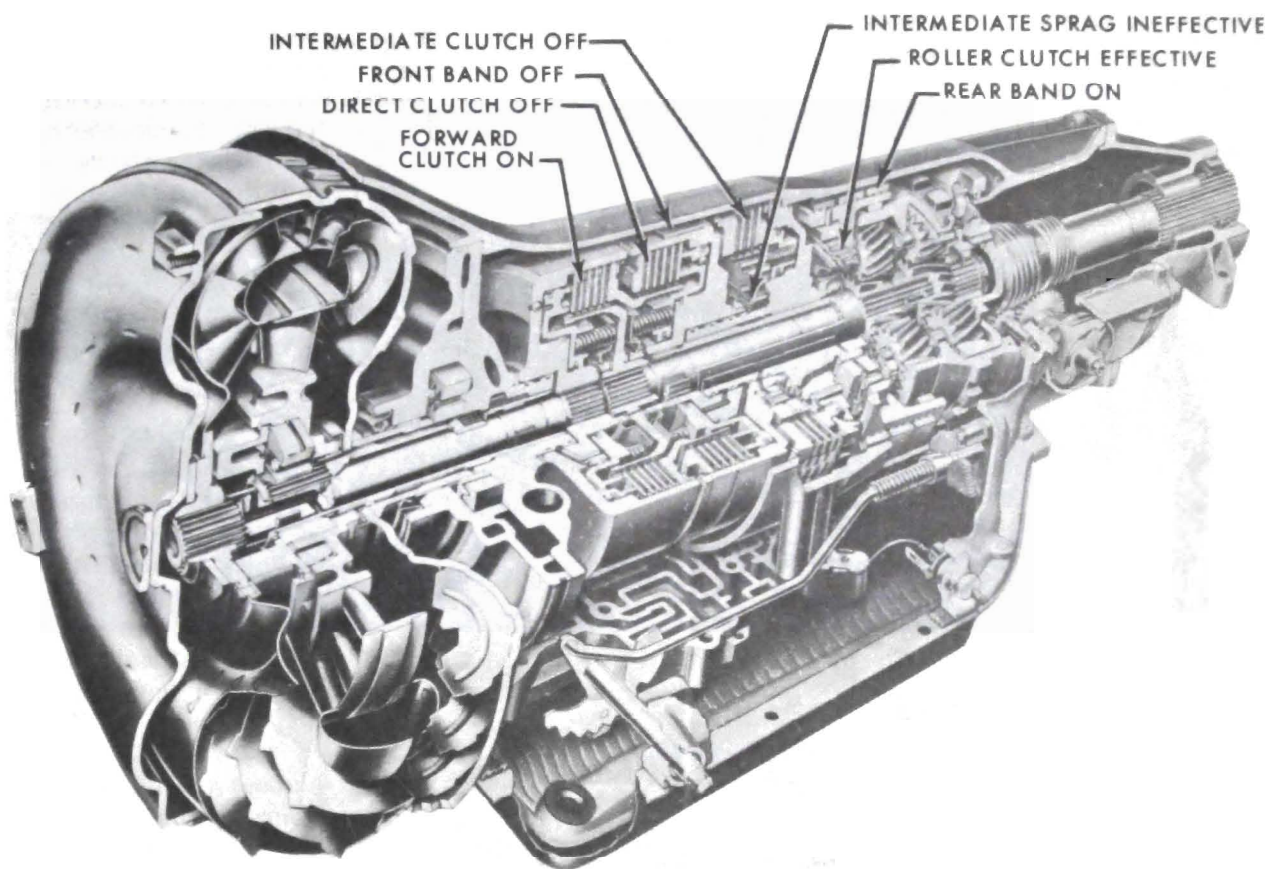

With the selector lever in L<sup>1</sup> Range, the forward clutch is applied. This delivers turbine torque to the mainshaft and turns the rear internal gear in a clockwise direction. (Converter torque ratio = approximately 2.:1. at stall.)

Clockwise motion of the rear internal gear causes the rear pinions to turn clockwise to drive the sun gear counterclockwise. In turn, the sun gear drives the front pinions clockwise, thus turning the front internal gear, output carrier, and output shaft clockwise in a reduction ratio of approximately 2.5:1. The reaction of the front pinions against the front internal gear is taken by the reaction carrier and the one way clutch. (Total stall ratio = approximately 5.:1.)

Downhill or overrun braking is provided in L<sup>1</sup> Range by applying the rear band as this prevents the reaction carrier from overrunning the one way clutch.

74-867A

Figure 76-207 - L1 Range - First Gear

## f. Operation of Components in Reverse

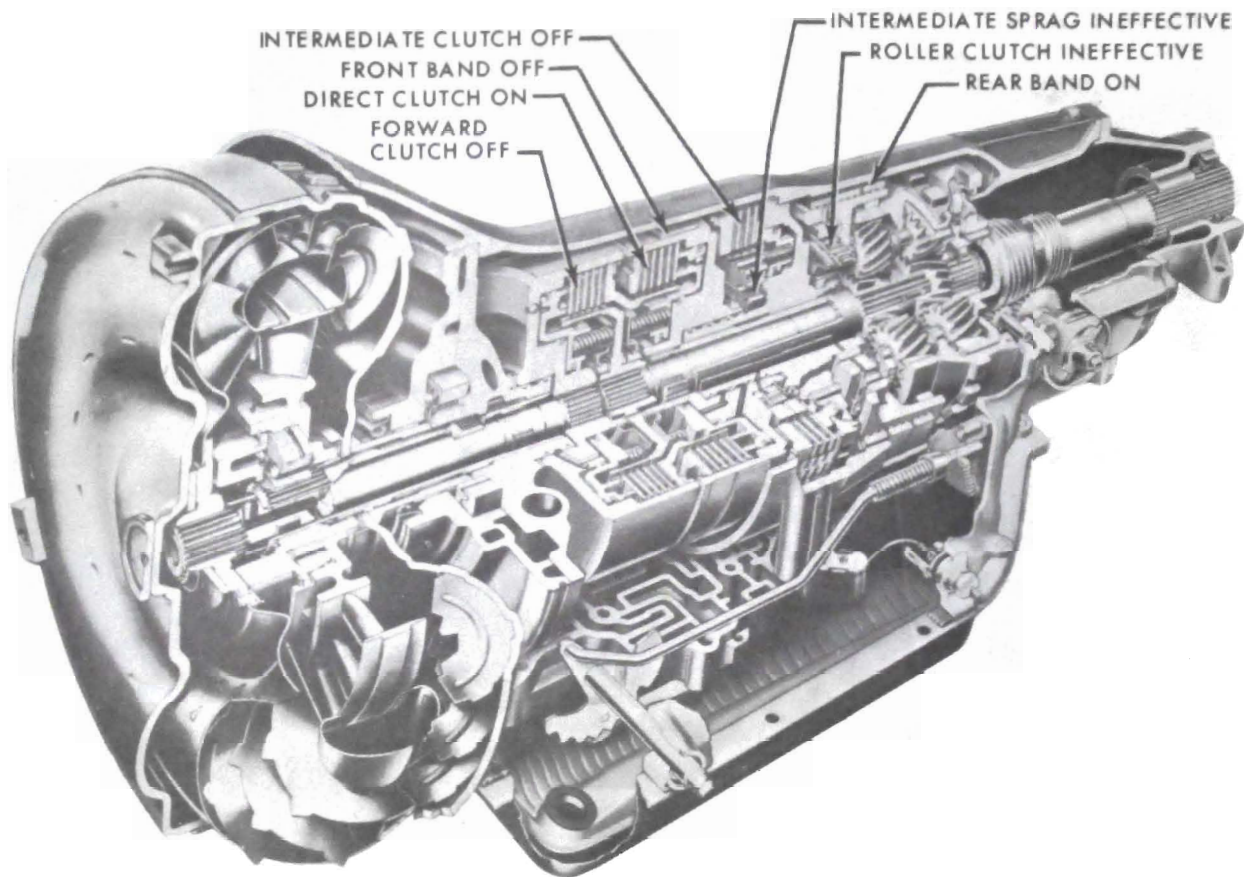

In Reverse, the direct clutch is applied to direct turbine torque to the sun gear shaft and sun gear. The rear band is also applied, holding the reaction carrier.

Clockwise torque to the sun gear causes the front pinions and front internal gear to turn counterclockwise in reduction. The front internal gear is connected directly to the output shaft, thus providing the reverse output gear ratio of approximately 2.:1. The approximate reverse torque multiplication at stall (converter and gear ratios) is approximately 4.:1.

74-868A

Figure 76-208 - Reverse

## 76-6 HYDRAULIC OPERATION, FUNCTIONS OF VALVES AND HYDRAULIC CONTROL UNITS

### a. Pressure Control

The transmission is automatically controlled by a hydraulic system. Hydraulic pressure is supplied by the transmission gear type oil pump, which is engine driven. Main line pressure is controlled by a pressure regulator valve train located in the pump. This regulator controls line pressure automatically, in response to a pressure signal from a modulator valve, in such a way that the torque requirements of the transmission are met and smooth shifts are obtained at all throttle openings. See Figure 76-209.

To control line pressure properly, modulator pressure is used which varies in the same manner as torque input to the transmission. Since the converter torque output is the product of engine torque and converter ratio, modulator pressure must compensate for changes in either or both of these.

To meet these requirements, modulator pressure is regulated by engine vacuum which is an indicator of engine torque and carburetor opening. It is decreased by governor pressure with increase in vehicle speed because converter torque ratio also decreases.

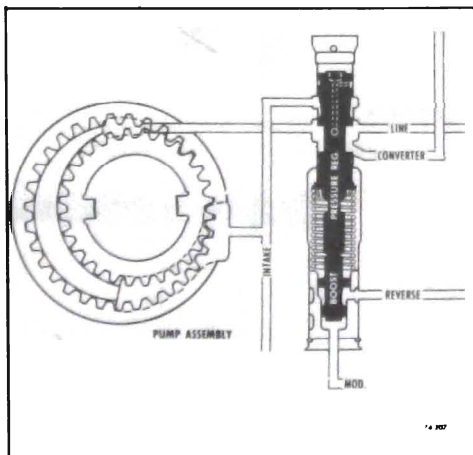

Figure 76-209 - Pump and Pressure Regulator Valve

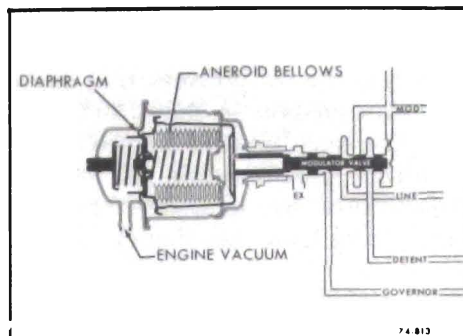

Figure 76-210 - Vacuum Modulator Assembly

### b. Vacuum Modulator Assembly

The engine vacuum signal is provided by the vacuum modulator, which consists of an evacuated metal bellows, a diaphragm and two springs. These are so arranged that when installed, the bellows and its external spring apply a force which acts on the modulator valve. This force acts on the modulator valve so that it increases modulator pressure. Engine vacuum and the internal spring act in the opposite direction to decrease modulator, or low engine vacuum high modulator pressure; high engine vacuum, and low modulator pressure. See Figure 76-210.

To reduce the effect of altitude on shift points, the effective area of the diaphragm is made somewhat larger than that of the bellows. Atmospheric pressure then acts on the resulting differential area to reduce modulator pressure.

### c. Governor Assembly

The vehicle speed signal to the modulator valve is supplied by the transmission governor, which is

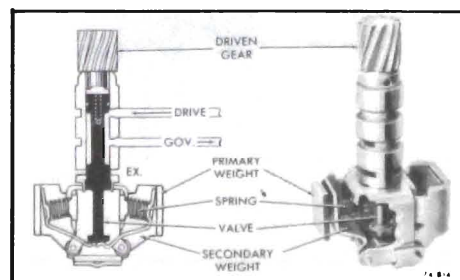

Figure 76-211 - Governor Assembly

driven by the output shaft. The governor consists of two flyweights and a regulator valve. Centrifugal force of the flyweights is imposed on the regulator valve causing it to regulate a pressure signal that increases with speed. See Figure 76-211.

To increase the accuracy of the governor signal at low speeds, the flyweights are so designed that their effective mass is greater at speeds below approximately 720 output RPM than it is above this speed.

This is done by dividing each flyweight into two parts and arranging them so that the primary weights act through preloaded springs on the secondary weights, which in turn acts on the valve. At approximately 720 RPM the centrifugal force on each primary weight exceeds the spring force and the primary weights move to a grounded stop. With the primary weights grounded, the force on the governor regulator valve is equal to the spring forces, plus the centrifugal force on the secondary weights.

Governor pressure acts on the modulator valve to cause modulator pressure to decrease as vehicle speed increases.

### 1. Pressure Regulator

a. Regulates line pressure according to a fixed spring force and forces controlled by modulator and reverse pressure. See Figure 76-209.

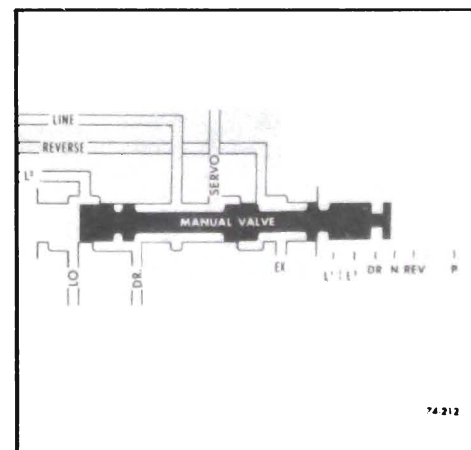

Figure 76-212 Manual Valve

b. Controls the flow of oil that charges the torque converter, feeds the oil cooler and provides lubrication for the transmission.

## 2. Manual Valve

Establishes the range of transmission operation, i.e. P, R, N, D, L2, L1, as selected by the vehicle operator through the manual control lever. See Figure 76-212.

## 3. Governor Assembly

Generates a speed sensitive oil pressure that increases with output shaft or vehicle speed. Governor pressure is used to vary the shift points and modulator pressure regulation. See Figure 76-211.

## 4. Modulator Valve

Regulates line pressure to modulator pressure that varies with torque to the transmission. See Figure 76-210. It senses forces created by:

- The vacuum modulator bellows that increases modulator pressure.
- Engine vacuum acting on a diaphragm to decrease modulator pressure.
- Governor pressure which is generated by the governor assembly. Governor pressure tends to decrease modulator pressure.

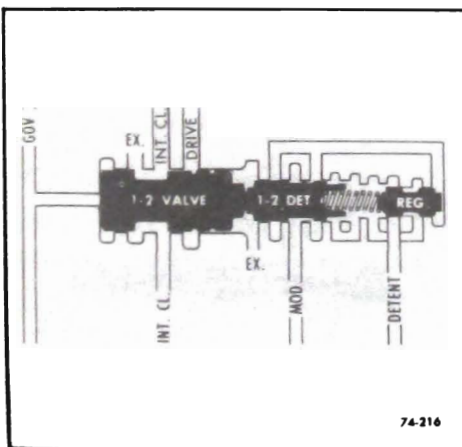

Figure 76-213 - 1-2 Shift Valve and 1-2 Detent Valve and Regulator Valve

## 5. 1-2 Shift Valve

Controls the oil pressure that causes the transmission to shift from 1-2 or 2-1. Its operation is controlled by governor pressure, low oil pressure, detent pressure, modulator pressure, and spring force. See Figure 76-213.

## 6. 1-2 Regulator Valve

Regulates modulator pressure to a pressure proportional to modulator pressure, tending to keep the 1-2 shift valve in the downshift position. See Figure 76-213.

## 7. 1-2 Detent Valve

Senses regulated modulator pressure tending to hold the 1-2 shift valve in the downshift position and provides an area for detent pressure for detent 2-1 shifts. See Figure 76-213.

## 8. 2-3 Shift Valve

Controls the oil pressure that causes the transmission to shift from 2-3 or 3-2. Its operation is controlled by modulator, L2, governor and detent pressure as well as a spring force. See Figure 76-214.

## 9. 2-3 Modulator Valve

Senses modulator pressure to apply a variable force proportional to modulator pressure which tends to hold the 2-3 shift valve downshifted. See Figure 76-214.

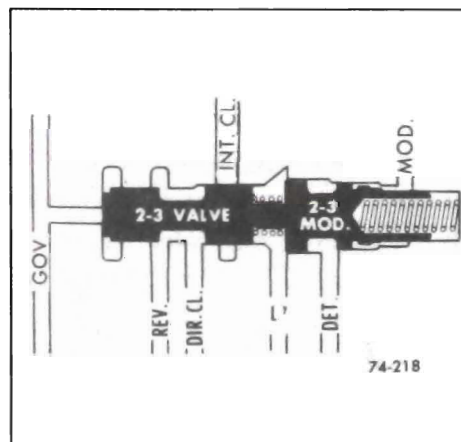

Figure 76-214 - 2-3 Valve and 2-3 Modulator Valve Train

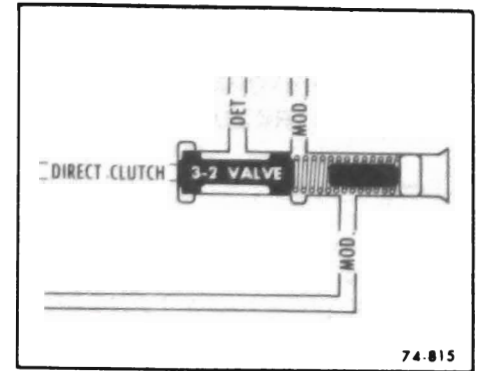

Figure 76-215 - 3-2 Valve

## 10. 3-2 Valve

Shuts off modulator pressure from acting on the shift valve trains after the direct clutch has been applied. This allows fairly heavy throttle operation in third gear without downshifting. In third speed, modulator pressure or detent pressure above 87 psi will provide part throttle downshift forces. (Resulting in a 3-2 downshift at less than wide open throttle) See Figure 76-215.

## 11. Detent Valve

Shifts when line oil is exhausted at the end of the valve when the detent solenoid is energized. Thus allowing the detent regulator valve to regulate. This directs detent pressure to the 1-2 accumulator valve, 1-2 regulator and 2-3 modulator valves, 3-2 valve, and the vacuum modulator valve. See Figure 76-216.

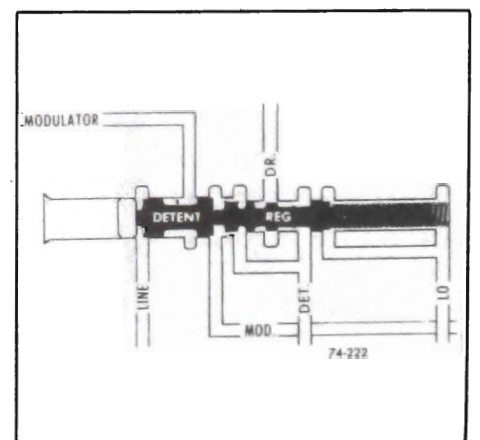

Figure 76-216 - Detent Valve and Detent Regulator Valve

## 12. Detent Regulator Valve

When the detent valve shifts, the detent regulator is free to allow drive oil to enter the detent passage and thus becomes regulated to a value of 70 psi. Detent pressure will also flow into the modulator passage which flows to the 2-3 modulator valve, 3-2 valve and the 1-2 detent valve. Lo oil moves the detent regulator open to drive oil allowing drive oil to enter the modulator and detent passages. See Figure 76-216.

## 13. Front Servo

The front servo, see Figure 76-217, applies the front overrun band to provide engine braking in 2nd gear in L2 Range. It is also used as an accumulator for the application of the direct clutch and in conjunction with a series of check balls and controlling orifices is a part of the timing for the release of the direct clutch.

To prevent the application of the front overrun band in Neutral, Drive and Reverse ranges, oil is directed

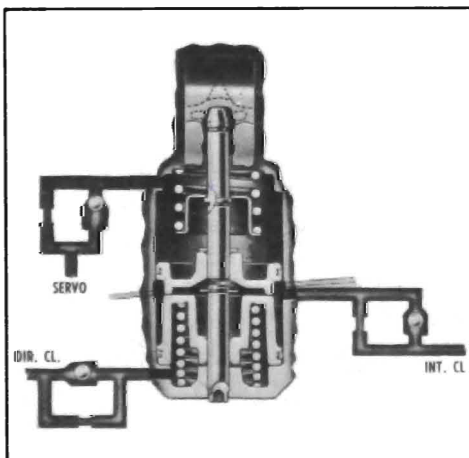

Figure 76-217 - Front Servo

from the manual valve to the release side of the servo piston.

In Drive range the servo release oil from the manual valve also acts to charge the servo in preparation for the application of the direct clutch.

Direct clutch oil is directed to the front servo accumulator piston where spring force plus direct clutch pressure stroke the piston up against the force of servo release oil. This lowers the clutch apply pressure during the shift for a smooth engagement.

The release of the direct clutch and the exhausting of the front servo accumulator is slowed down by three check balls and three orifices which permits a soft return of the drive load to the intermediate sprag and also allows engine RPM to increase during a detent 3-2 downshift in preparation for the lower gear ratio, which results in a smooth shift and better acceleration.

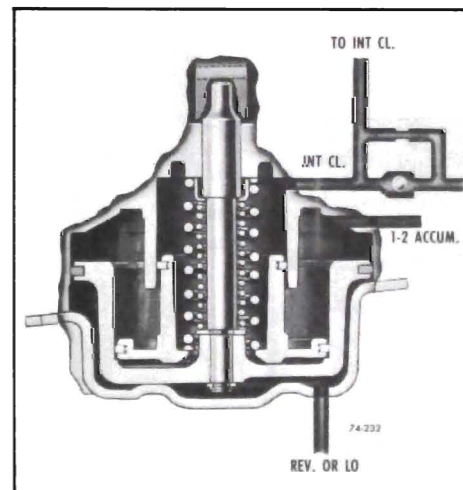

Figure 76-218 - Rear Servo

## 14. Rear Servo

The rear servo, see Figure 76-218, applies the rear band for overrun engine braking in L1 range 1st gear. It applies the band in Reverse to hold the reaction carrier to provide the reverse gear ratio.

## 15. 1-2 Accumulator

1-2 accumulator oil charges the rear servo accumulator in 1st gear in preparation for the apply of the intermediate clutch on the 1-2 shift.

The valve train consists of a 1-2 primary valve and spring, a 1-2 accumulator valve and spring and plug. See Figure 76-220.

1-2 accumulator oil pressure is a two-stage pressure which increases as modulator pressure increases to obtain greater flexibility in obtaining the desired curve during the 1-2 shift for various engine requirements.

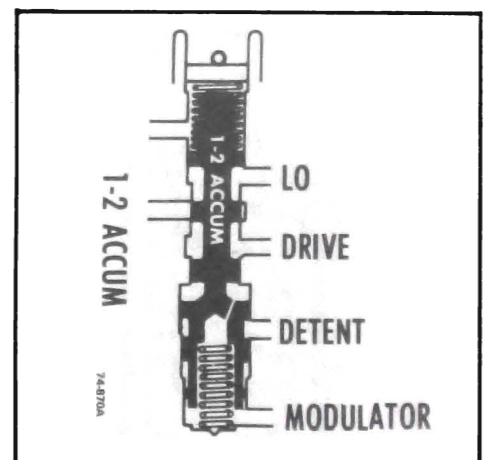
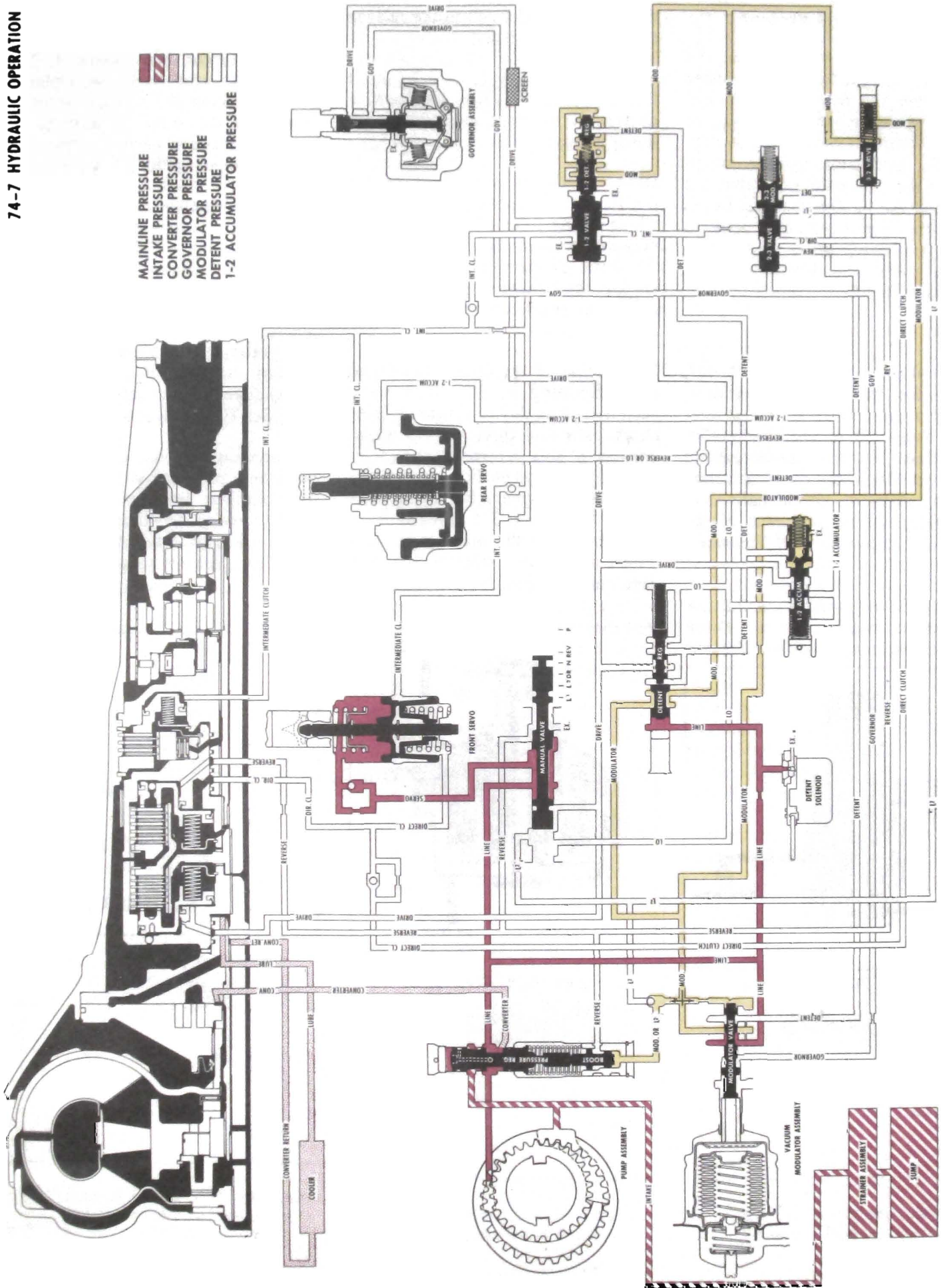

Figure 76-220 - 1-2 Accumulator Valve Train



74-7 HYDRAULIC OPERATION



- MAINLINE PRESSURE
- INTAKE PRESSURE
- CONVERTER PRESSURE
- GOVERNOR PRESSURE
- MODULATOR PRESSURE
- DETENT PRESSURE
- 1-2 ACCUMULATOR PRESSURE

Figure 76-223 - Park or Neutral

**a. Operation of Controls**  
**Park or Neutral (throttle closed)**

Forward Clutch	— Off	Front Band	— Off	Intermediate Sprag	— Ineffective
Direct Clutch	— Off	Rear Band	— Off	Detent Solenoid	— De-energized
Intermediate Clutch	— Off	Roller Clutch	— Ineffective		

Whenever the engine is running at idle with the selector lever in "P" or "N", oil from the pump is directed to the: (See Figure 76-223.)

1. Pressure Regulator Valve
2. Converter
  - a. Oil Cooler
  - b. Lubrication System
3. Manual Valve
4. Detent Valve
5. Detent Solenoid
6. Vacuum Modulator Valve
7. Front Servo (Neutral Only)

Line pressure acts on the:

1. Manual Valve
2. Detent Valve
3. Detent Solenoid
4. Modulator Valve
5. Front Servo Piston (Neutral Only)

fill the converter. Oil from the converter, termed converter return oil, is directed to the transmission cooler. Oil from the cooler is directed to the transmission lubrication system.

Line pressure at the modulator valve is regulated to a pressure called modulator oil, which acts on the pressure boost valve, 1-2 accumulator and 1-2 accumulator primary valve and passes through the detent valve and 3-2 valve to the 1-2 detent valve and 2-3 modulator valve.

**Cooling and Lubrication**

Oil flows from the pump to the pressure regulator valve which regulates the pump pressure. When the pump output exceeds the demand of line pressure, oil from the pressure regulator is directed to the converter feed passage to

**SUMMARY**

The converter is filled and all clutches and bands are released. The transmission is in Neutral.



**b. Operation of Controls**  
**Drive Range — First Gear**

Forward Clutch — On  
 Direct Clutch — Off  
 Intermediate Clutch — Off

Front Band — Off  
 Rear Band — Off  
 Roller Clutch — Effective

Intermediate Sprag — Ineffective  
 Detent Solenoid — De-energized

When the selector lever is moved into Drive position, the manual valve is repositioned to allow line pressure to enter the drive circuit. Drive oil then flows to the: (See Figure 76-224.)

1. Forward Clutch
2. 1-2 Shift Valve
3. Governor Assembly
4. 1-2 Accumulator Valve
5. Detent Regulator Valve

clutch piston to apply the forward clutch. The first, or inner area, is fed through an unrestricted passage. The outer area is fed through an orifice to insure a smooth shift from Park, Neutral and Reverse to Drive.

Drive oil at the governor assembly is regulated to a variable pressure. This pressure, called governor oil, increases with vehicle speed and acts against the ends of the 1-2 and 2-3 shift valves and an area on the modulator valve.

Drive oil is also regulated to another variable pressure at the 1-2 accumulator valve. This pressure, called 1-2 accumulator oil, is controlled by modulator oil and is directed to the rear servo. 1-2 Accumulator oil at the rear servo acts on the accumulator piston.

**Summary**

The converter is filled. The forward clutch is applied. The transmission is in first gear.

76-40

**Basic Control**

Drive oil is directed to the forward clutch where it acts on two areas of the



### c. Operation of Controls

#### Drive Range — Second Gear

Forward Clutch	— On	Front Band	— Off	Intermediate Sprag	— Effective
Direct Clutch	— Off	Rear Band	— Off	Detent Solenoid	— De-energized
Intermediate Clutch	— On	Roller Clutch	— Ineffective		

As both vehicle speed and governor pressure increase, the force of governor oil acting on the 1-2 shift valve will overcome the force of re-regulated modulator oil pressure. This allows the 1-2 shift valve to open, permitting drive oil to enter the intermediate clutch passage. Oil in this passage is called intermediate clutch oil. (See Figure 76-225.)

Intermediate clutch oil from the 1-2 shift valve is directed to the:

1. Intermediate Clutch
2. Rear Servo
3. Front Servo and Accumulator Pistons
4. 2-3 Shift Valve

#### Basic Control

Intermediate clutch oil from the 1-2 shift valve seats a one-way check ball and flows through an orifice to the intermediate clutch piston to apply the intermediate clutch. At the same time, intermediate clutch oil moves the accumulator piston against the 1-2 accumulator oil and accumulator spring to maintain lower pressure in the clutch during a 1-2 shift for a smooth clutch apply. Intermediate clutch oil seats a second one-way check ball and flows to the front servo and accumulator pistons. Intermediate clutch oil is also directed to a land of the 2-3 shift valve.

#### SUMMARY

The forward and intermediate clutches are applied. The transmission is in second gear.

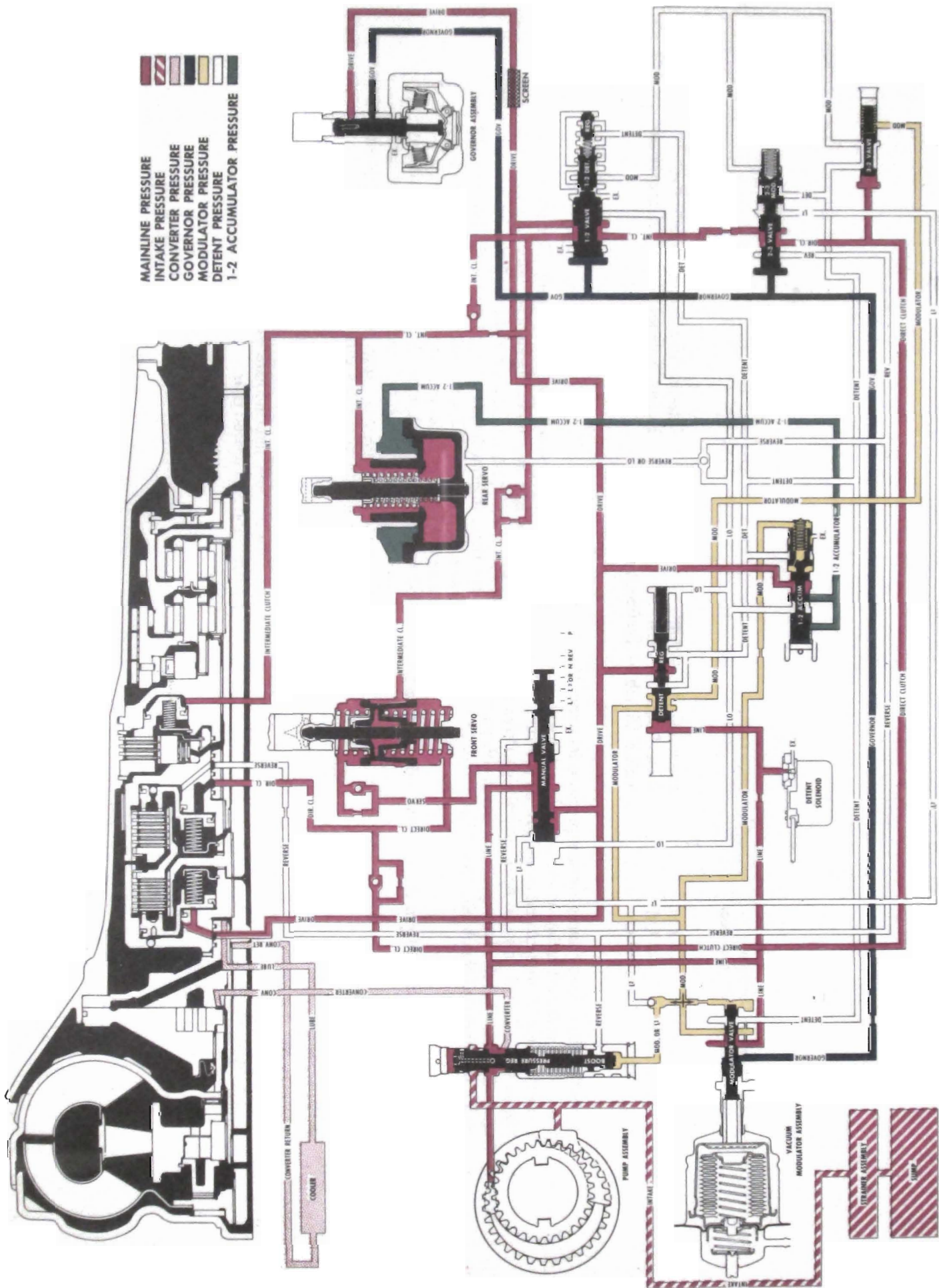

Figure 76-226 - Drive Range - Third Gear

**d. Operation of Controls  
Drive Range — Third Gear**

Forward Clutch	— On	Front Band	— Off	Intermediate Sprag	— Ineffective
Direct Clutch	— On	Rear Band	— Off	Detent Solenoid	— De-energized
Intermediate Clutch	— On	Roller Clutch	— Ineffective		

As vehicle speed and governor pressure increase, the force of governor oil acting on the 2-3 shift valve overcomes the force of the 2-3 shift valve spring and modulator oil. This allows the 2-3 shift valve to move, feeding intermediate clutch oil to the direct clutch passage. This oil is termed direct clutch oil. (See Figure 76-226.)

Direct clutch oil from the 2-3 shift valve is directed to the:

1. Direct Clutch
2. Front Accumulator Piston
3. 3-2 Valve

**Basic Control**

Direct clutch oil from the 2-3 shift valve flows past a one-way check valve to the inner area of the direct clutch piston

to apply the direct clutch. Simultaneously, direct clutch oil is fed to the front accumulator piston. The pressure of the direct clutch oil, combined with the accumulator spring, moves the accumulator and servo pistons against servo oil. This acts as an accumulator for a smooth direct clutch assembly.

Direct Clutch oil is also supplied to the 3-2 valve to move against modulator pressure. This cuts off modulator oil to the 1-2 detent and 2-3 modulator valves and allows the transmission to utilize the torque multiplying characteristics of the converter during medium throttle operation without downshifting.

**SUMMARY**

The forward, intermediate and direct clutches are applied. The transmission is in third gear (direct drive).



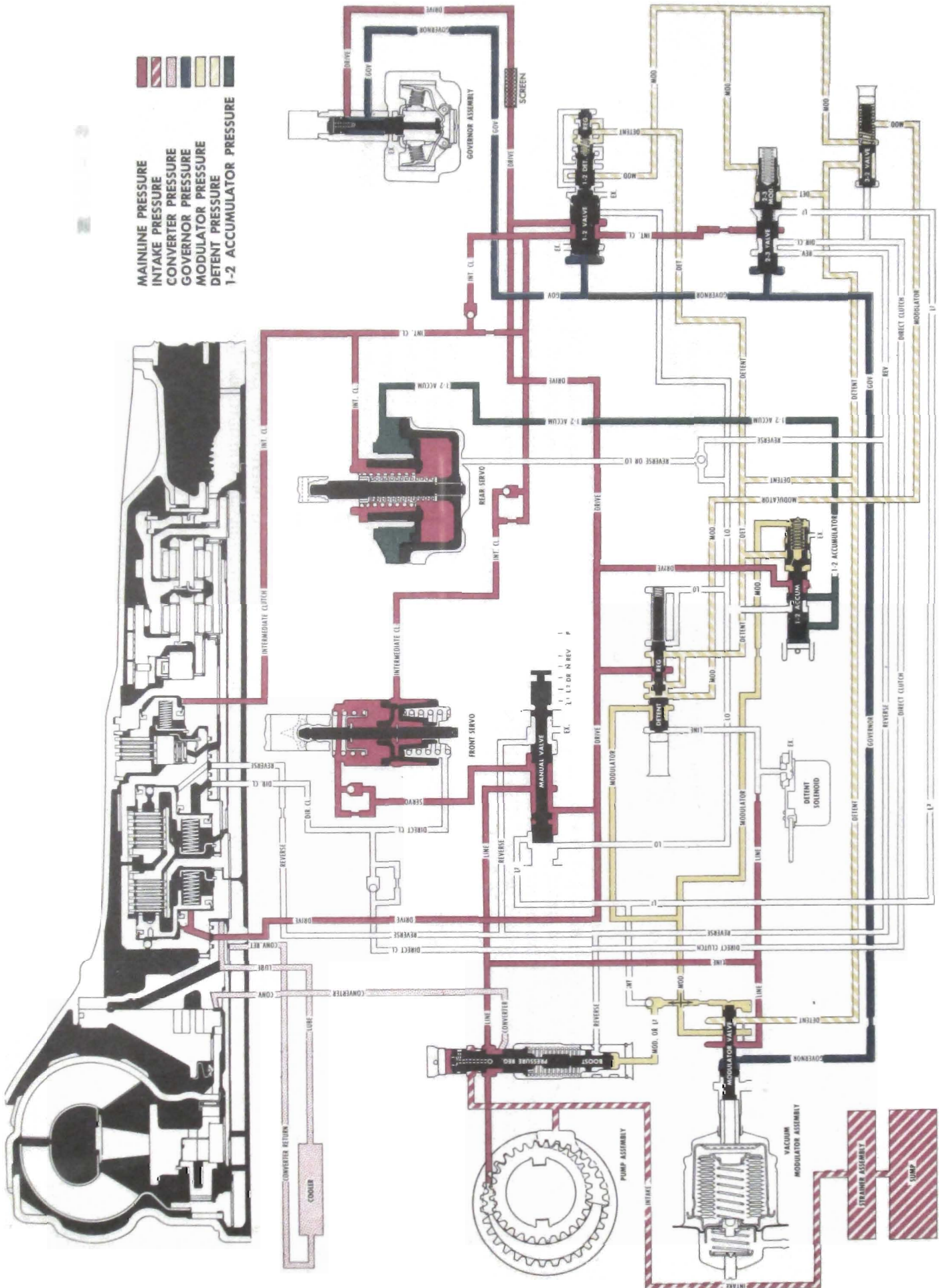

MAINLINE PRESSURE  
 INTAKE PRESSURE  
 CONVERTER PRESSURE  
 GOVERNOR PRESSURE  
 MODULATOR PRESSURE  
 DETENT PRESSURE  
 1-2 ACCUMULATOR PRESSURE

Figure 76-227 - Detent Downshift - Valves in Second Gear Position

**e. Operation of Controls**  
**Detent Down Shift — Valves in**  
**Second Gear Position**

Forward Clutch	— On	Front Band	— Off	Intermediate Sprag	— Effective
Direct Clutch	— Off	Rear Band	— Off	Detent Solenoid	— Energized
Intermediate Clutch	— On	Roller Clutch	— Ineffective		

While operating at speeds below approximately 70 MPH a forced detent 3-2 downshift is possible by depressing the accelerator fully. This engages an electrically operated switch and actuates the detent solenoid. The detent solenoid opens an orifice that allows line oil at the detent valve to be exhausted, thus permitting the detent regulator valve to operate. Line oil acting on the detent valve and solenoid is supplied by a smaller orifice. (See Figure 76-227.)

Drive oil on the detent regulator valve is then regulated to a pressure of approximately 70 psi and called detent oil. Detent oil is then routed to the:

1. Modulator Passage
2. 1-2 Regulator Valve
3. 2-3 Modulator Valve
4. 3-2 Valve
5. 1-2 Primary Accumulator Valve

**PART THROTTLE 3-2 DOWNSHIFTS**

Forward Clutch	— Applied	Rear Band	— Released
Roller Clutch	— Ineffective	Intermediate Clutch	— Applied
Direct Clutch	— Released in 2nd	Intermediate Sprag	— Effective in 2nd
Direct Clutch	— Applied in 3rd	Intermediate Sprag	— Ineffective in 3rd
Front Band	— Released		

A part throttle 3-2 downshift can be accomplished below approximately 33 mph by depressing the accelerator far enough to raise modulator pressure to approximately 87 psi. Modulator pressure and the 3-2 valve spring will move the

**6. Vacuum Modulator Valve**

Detent oil in the modulator passage and at the 2-3 modulator valve will close the 2-3 shift valve below approximately 70 MPH, shifting the transmission to second gear.

A detent 2-1 downshift can also be accomplished below approximately 20 MPH because detent oil is directed to the 1-2 regulator valve, regulating or exhaust port. This allows detent oil to act on the 1-2 regulator and 1-2 detent valve to close the 1-2 shift valve, shifting the transmission to first gear.

To insure intermediate clutch durability during 1-2 upshifts under detent conditions, detent oil is directed to the 1-2 accumulator primary valve to increase 1-2 accumulator oil pressure acting on the rear servo accumulator piston.

Detent oil is also directed to the modulator valve to prevent modulator pressure from regulating below 70 psi at high speeds or at high altitudes.

3-2 valve against direct clutch oil and allow modulator oil to act on the 2-3 modulator valve. This moves the 2-3 valve train against governor oil and shifts the transmission to second speed.



**f. Operation of Controls**  
**L<sup>2</sup> Range — Valves in Second**  
**Gear Position**

Forward Clutch	— On	Front Band	— On	Intermediate Sprag	— Effective
Direct Clutch	— Off	Rear Band	— Off	Detent Solenoid	— De-energized
Intermediate Clutch	— On	Roller Clutch	— Ineffective		

A 3-2 downshift can be accomplished by moving the selector lever from Drive to L<sup>2</sup> Range. When the selector lever is in the L<sup>2</sup> Range, L<sup>2</sup> oil from the manual valve is directed to the: (See Figure 76-228.)

1. Pressure Boost Valve
2. 2-3 Shift Valve

For engine braking the front band is applied by exhausting servo oil at the manual valve in L<sup>2</sup> Range. This allows intermediate clutch oil, acting on the servo piston, to move the piston and apply the front band. Once the transmission is in second gear — L<sup>2</sup> Range, it cannot upshift to third gear regardless of vehicle speed.

**SUMMARY**

L<sup>2</sup> oil at the boost valve will increase line pressure to 150 psi. This increased L<sup>2</sup> oil pressure at the 2-3 shift valve will close the 2-3 shift valve, regardless of car speed.

The forward and intermediate clutches and front band are applied. The transmission is in second gear — L<sup>2</sup> Range.



**g. Operation of Controls  
L' Range — First Gear —  
Valves in First Gear Position**

Forward Clutch	— On	Front Band	— Off	Intermediate Sprag	— Ineffective
Direct Clutch	— Off	Rear Band	— On	Detent Solenoid	— De-energized
Intermediate Clutch	— Off	Roller Clutch	— Effective		

Maximum downhill braking can be attained at speeds below 40 mph with the selector lever in L' Range as this directs Lo oil from the manual valve to the: (See Figure 76-229.)

1. Rear Servo
2. 1-2 Accumulator Valve
3. Detent Regulator Valve

**Basic Control**

Lo oil flows past a ball check to the apply side of the rear servo piston and to the 1-2 accumulator valve to raise the 1-2 accumulator oil to line pressure for a smooth band apply.

Lo oil acts on the detent regulator valve. Combined with the detent spring, Lo oil holds the detent valve against line oil acting on the detent valve, causing drive oil to flow through the detent regulator valve into the detent and modulator passages. Modulator and detent oil at line pressure acting on the 1-2 regulator and 1-2 detent valve overcomes governor oil on the 1-2 shift valve at any vehicle speed below approximately 30-40 MPH and the transmission will shift to first gear.

With the transmission in first speed — L' Range, the transmission cannot upshift to second gear regardless of vehicle or engine speed. The forward clutch and rear band are applied. The transmission is in first gear — L' Range.

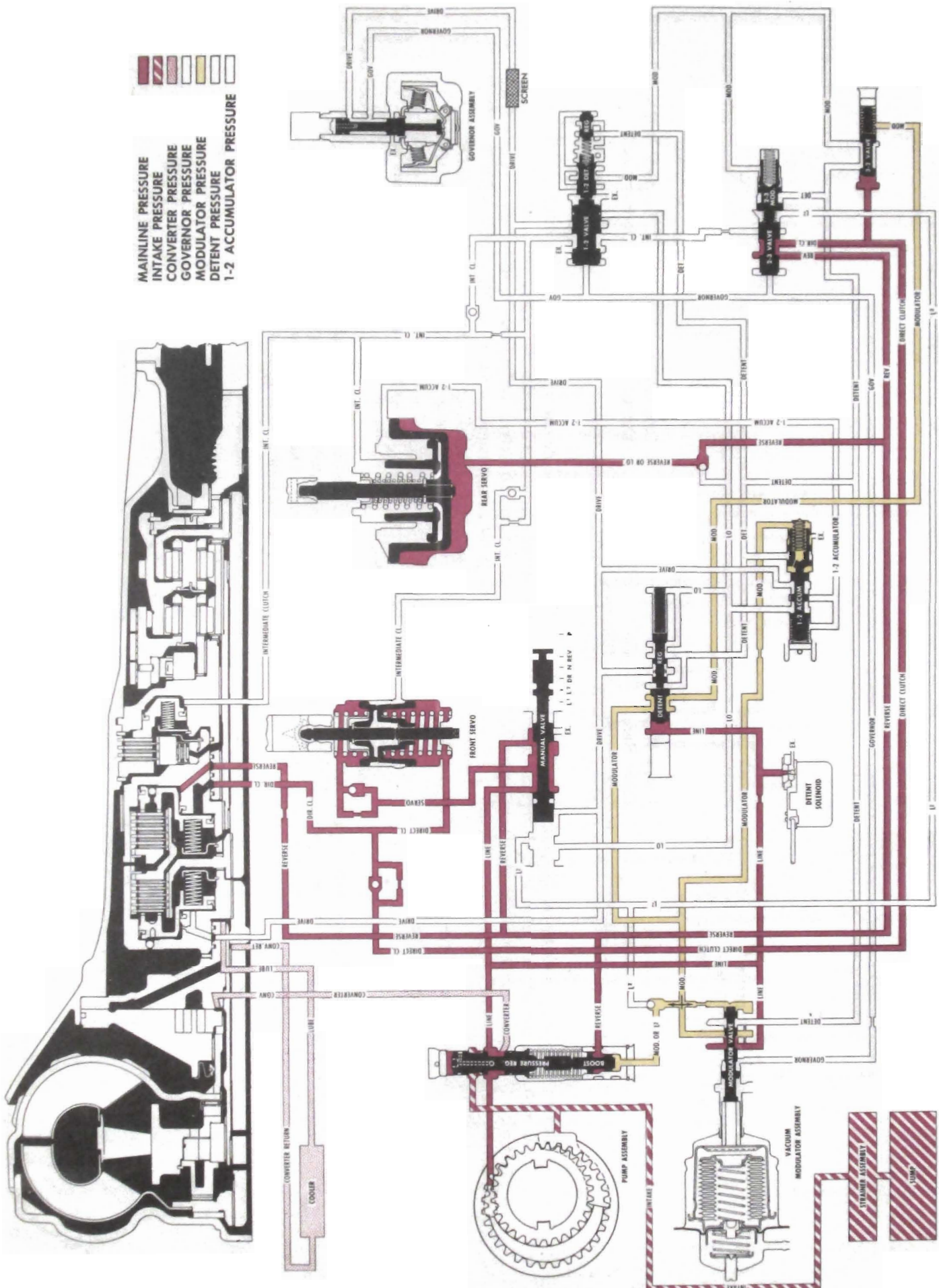

MAINLINE PRESSURE  
INTAKE PRESSURE  
CONVERTER PRESSURE  
GOVERNOR PRESSURE  
MODULATOR PRESSURE  
DETENT PRESSURE  
1-2 ACCUMULATOR PRESSURE

76-72

Figure 76-230 - Reverse

#### h. Operation of Controls Reverse

Forward Clutch	— Off	Front Band	— Off	Intermediate Sprag	— Ineffective
Direct Clutch	— On	Rear Band	— On	Detent Solenoid	— De-energized
Intermediate Clutch	— Off	Roller Clutch	— Ineffective		

When the selector lever is moved to the Reverse position, the manual valve is repositioned to allow line pressure to enter the reverse circuit. Reverse oil then flows to the: (See Figure 76-230.)

1. Direct Clutch
2. 2-3 Shift Valve
3. Rear Servo Piston
4. Pressure Boost Valve

the direct clutch piston and to the 2-3 shift valve. From the 2-3 shift valve, it enters the direct clutch passage and is directed to the small area of the direct clutch piston to apply direct clutch.

Reverse oil seats a check ball and flows to the rear servo and acts on the servo piston to apply the rear band. Reverse oil also acts on the pressure boost valve to boost line pressure.

#### SUMMARY

The direct clutch and rear band are applied. The transmission is in Reverse.

#### Basic Control

Reverse oil from the manual valve flows to the large area of



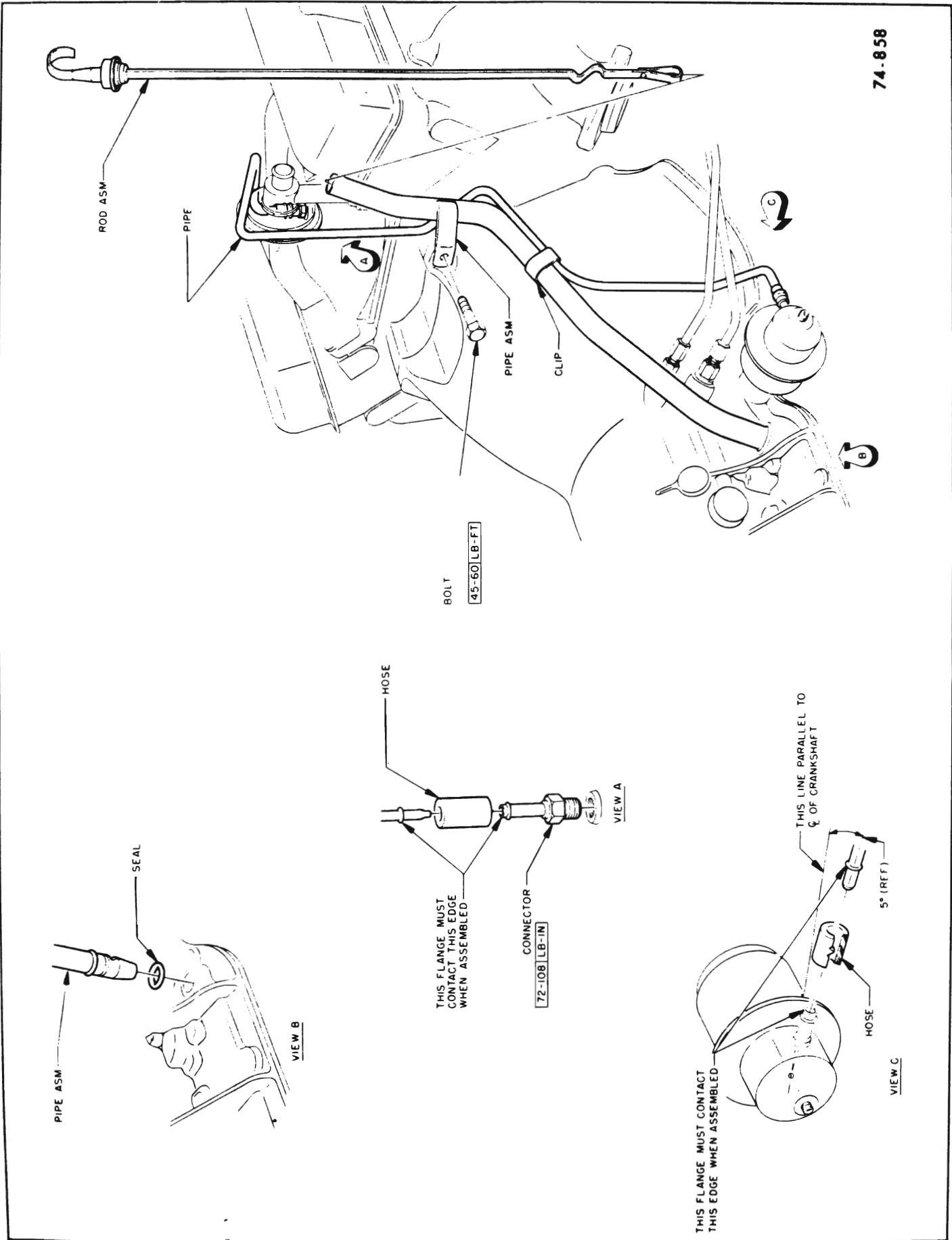

Figure 76-502 - Vacuum Modulator Line and Dipstick

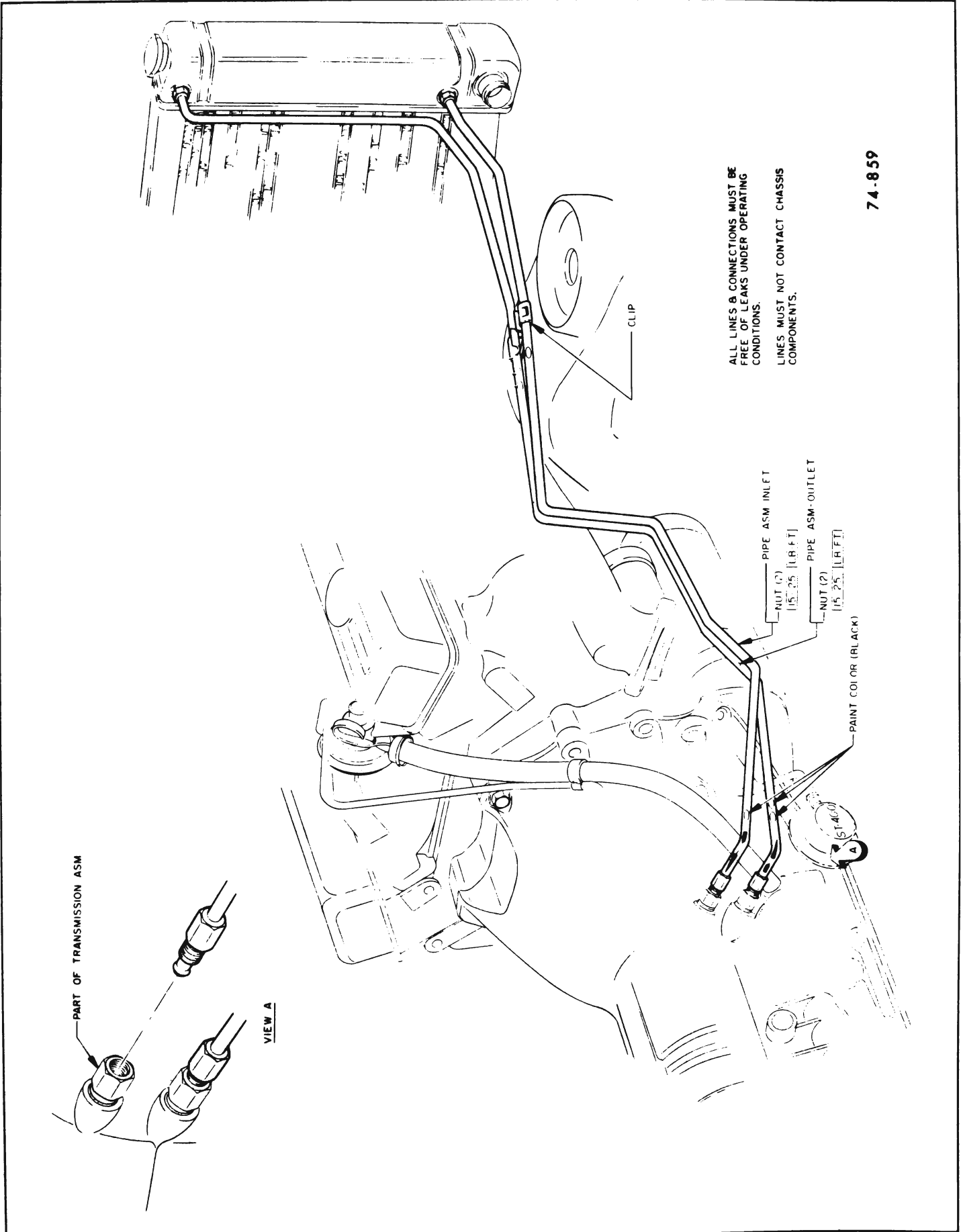

Figure 76-503 - Oil Cooler Lines

## DIVISION III

### SERVICE PROCEDURES

#### 76-8 TRANSMISSION ASSEMBLY - REMOVAL AND INSTALLATION

##### a. Removal

1. Raise car and provide support for front and rear of car.
2. Disconnect front exhaust crossover pipe if necessary.
3. Disconnect propeller shaft.
4. Place suitable jack under transmission and fasten transmission securely to jack.
5. Remove vacuum line from vacuum modulator. See Figure 76-502.
6. Loosen cooler line nuts and separate cooler lines from transmission. See Figure 76-503.
7. Remove transmission mounting pad to cross member bolts.
8. Remove transmission cross member support to frame rail bolts. Remove cross member.
9. Disconnect detent wire from transmission.
10. Disconnect speedometer cable.
11. Disconnect shift linkage from transmission.
12. Disconnect transmission filler pipe at engine. Remove filler pipe from transmission.
13. Support engine at oil pan.
14. Remove transmission flywheel cover pan to case tapping screws. **REMOVE FLYWHEEL COVER PAN.**
15. Mark flywheel and converter pump for reassembly in same position, and remove three converter pump to flywheel bolts.

16. Remove transmission case to engine block bolts.

17. Move transmission rearward to provide clearance between converter pump and crankshaft. Install Converter Holding Tool J-21366 to retain converter. Lower transmission and move to bench.

##### b. Installation

1. Assemble transmission to suitable transmission jack and raise transmission into position. Rotate converter to permit coupling of flywheel and converter with original relationship. Remove J-21366.

2. Install transmission case to engine block bolts. Torque to 30-40 lb. ft. Do not overtighten.

**CAUTION: Converter assembly must rotate freely by hand after converter pilot has been pushed forward into the engine crankshaft pilot hole.**

3. Install flywheel to converter pump bolts. Torque to 25-35 lb. ft.

4. Install transmission cross member support. Install mounting pad to cross member.

5. Remove transmission jack and engine support.

6. Install transmission flywheel cover pan with tapping screws.

7. Install transmission oil filler pipe using a new "O" ring.

8. Reconnect speedometer cable.

9. Connect detent wire.

10. Install propeller shaft.

11. Reinstall front exhaust crossover pipe, if removed.

12. Install oil cooler lines to transmission. See Figure 76-503.

13. Install vacuum line to vacuum modulator.

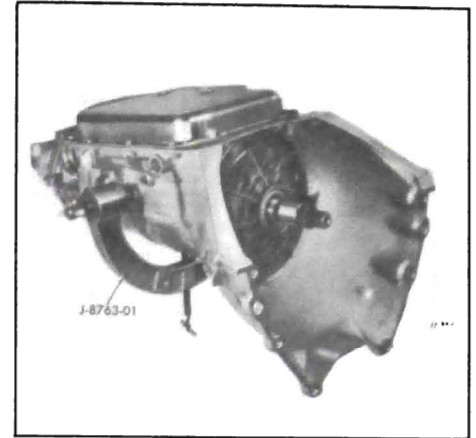

Figure 76-504

14. Fill transmission with fluid as described in Paragraph 76-1, subparagraph c.

#### 76-9 REMOVAL OF CONVERTER AND VACUUM MODULATOR

1. With transmission in portable jack, remove J-21366. Remove converter assembly, by pulling straight out.

**NOTE: The converter contains a large amount of oil.**

2. Install Holding Fixture J-8763-01 on the transmission so that the modulator assembly will be located on the side of the holding fixture that is nearest the bench.

3. Install fixture and transmission into Holding Tool Base, J-3289-20, with bottom pan facing up. See Figure 76-504.



Figure 76-505



Figure 76-506



Figure 76-508

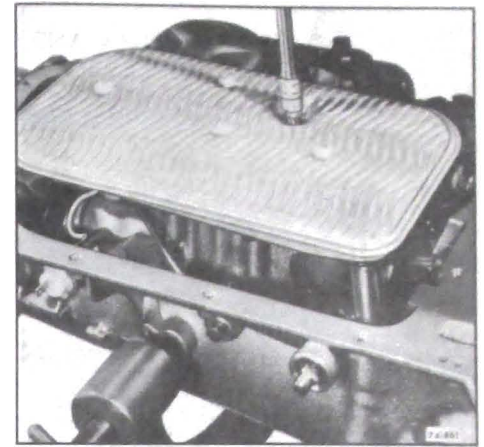

Figure 76-511

4. Remove modulator assembly attaching bolt and retainer. See Figure 76-505.

5. Remove modulator assembly and "O" ring seal from case. See Figure 76-506.

6. Remove modulator valve from transmission case.

#### 76-10 REMOVAL OF GOVERNOR, SPEEDOMETER DRIVEN GEAR, OIL PAN, AND FILTER

**NOTE:** The following operations can be performed with transmission in car.

1. Remove attaching bolts, governor cover and gasket. See Figure 76-507.

2. Withdraw governor assembly from case. See Figure 76-508.

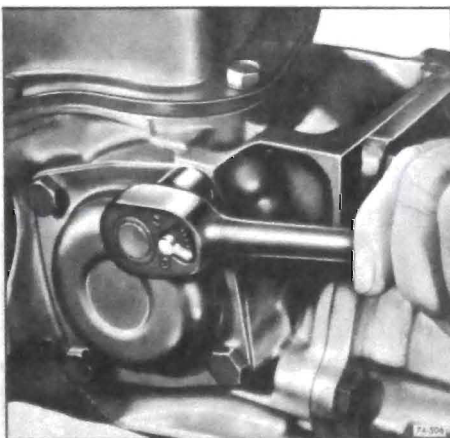

Figure 76-507

3. Remove speedometer driven gear attaching bolt and retainer. See Figure 76-509.

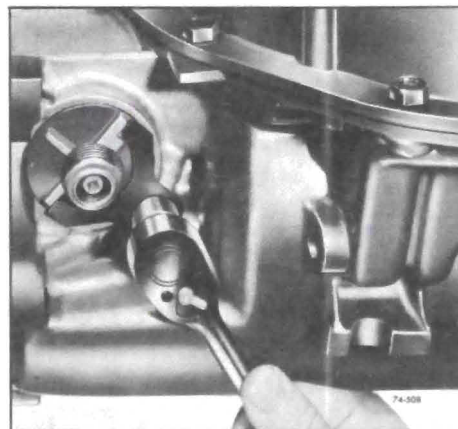

Figure 76-509

4. Withdraw speedometer driven gear assembly from case. See Figure 76-510.

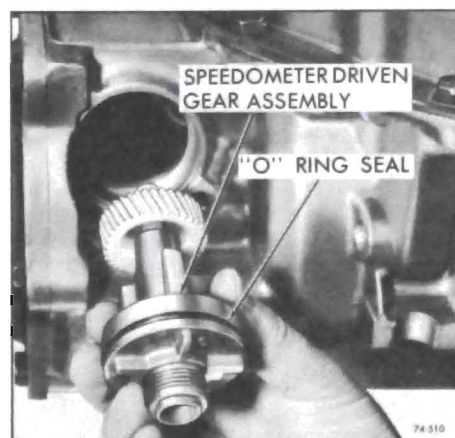

Figure 76-510

5. Remove oil pan attaching bolts.

6. Remove oil pan and gasket.

7. Remove the filter assembly retainer bolts. See Figure 76-511.

8. Remove filter and intake pipe assembly. See Figure 76-512.

9. Remove intake pipe to case "O" ring seal and discard. See Figure 76-512.

#### 76-11 REMOVAL OF VALVE BODY ASSEMBLY, GOVERNOR PIPES, AND DETENT SPRING ASSEMBLY

**NOTE:** The following operations can be performed with transmission in car.

1. Remove valve body attaching bolts and detent roller and spring assembly. See Figure 76-513.

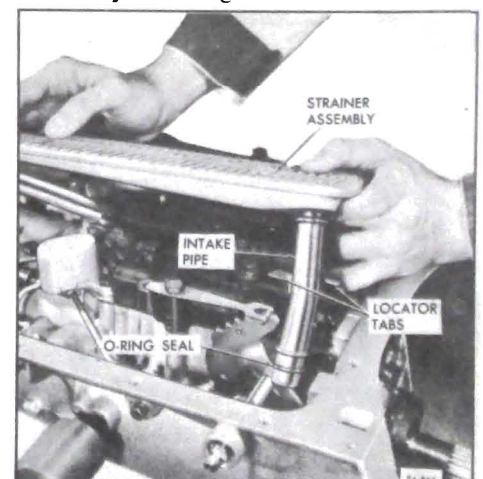

Figure 76-512

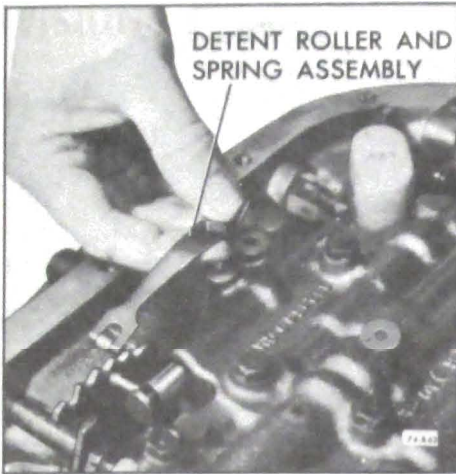

Figure 76-513

**NOTE: Do not remove solenoid attaching bolts.**

2. Remove valve body assembly and governor pipes. See Figure 76-514.

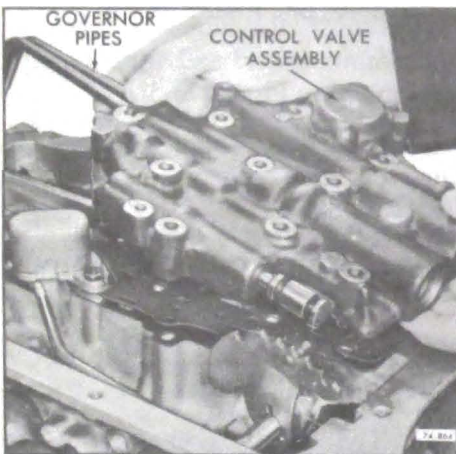

Figure 76-514

**NOTE: Do not allow manual valve to fall out of valve body assembly.**

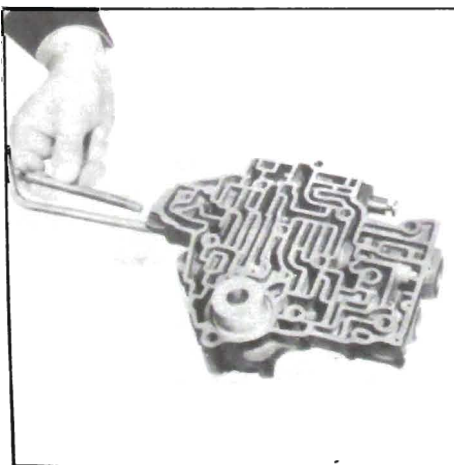

Figure 76-515

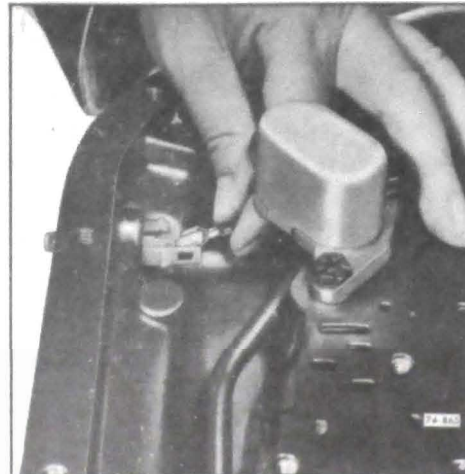

Figure 76-516

3. Remove governor pipes from valve body assembly. See Figure 76-515.

4. Disconnect detent solenoid wire from case connector. See Figure 76-516.

5. Remove valve body to spacer plate gasket. See Figure 76-517.

**76-12 REMOVAL OF SERVO, CASE SOLENOID CONNECTOR, VALVE BODY SPACER, GASKET FRONT SERVO, MANUAL DETENT, AND PARK LINKAGE**

1. Remove rear servo cover attaching bolts, servo cover, and gasket. (Discard gasket). See Figure 76-518.

2. Remove rear servo assembly from case. See Figure 76-520.

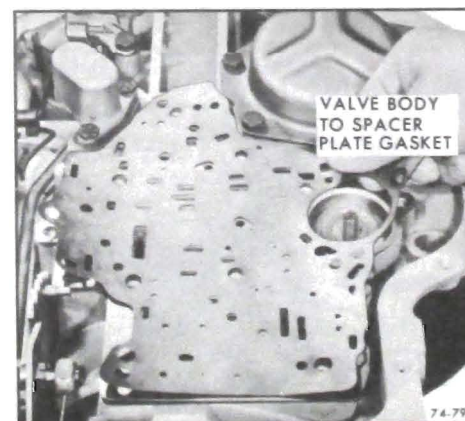

Figure 76-517

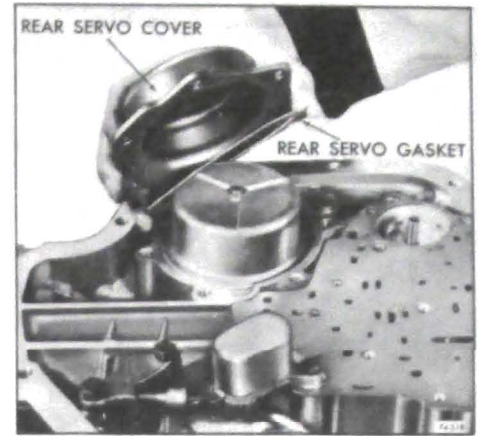

Figure 76-518

3. Remove servo accumulator spring. See Figure 76-521.

4. Check band apply Pin.

a. Attach band apply pin Selection

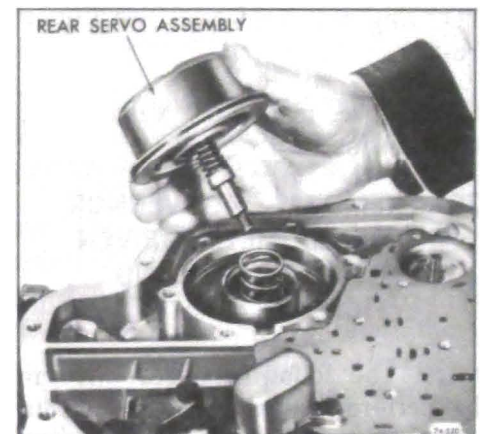

Figure 76-520

Gage J-21370-6 with J-21370-5, to transmission case with attaching bolts. Torque 6-10 lb.ft.

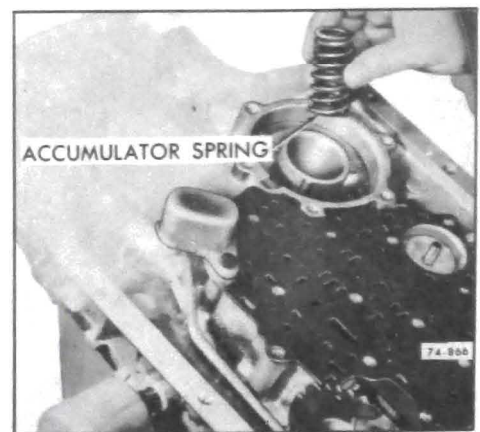

Figure 76-521

Apply 25 lb.ft. torque and *select proper pin to be used during assembly of transmission.* See Figure 76-522.

There are three selective pins identified as follows:

Pin Identification	Pin Size
3 Rings	Long
2 Rings	Medium
1 Ring	Short

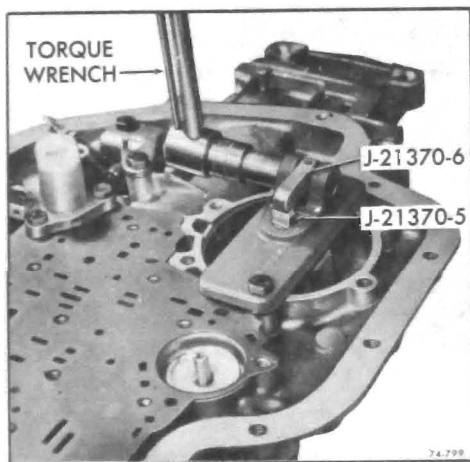

Figure 76-522

If both steps of J-21370-5 are below the gage surface, the long pin should be used. If the gage surface is between the steps, the medium length pin should be used. The short pin should be used if both steps of the gage pin are above the gage surface.

The identification ring is located on the band lug end of the pin. Selecting the proper pin is the equivalent of adjusting the band.

**NOTE:** If a new pin is required, make note of pin size required, and remove gage from transmission case.

5. Compress fingers on case connector sleeve and withdraw. See Figure 76-523.



Figure 76-523

6. Remove detent solenoid attaching bolts, solenoid assembly, and gasket. See Figure 76-524.

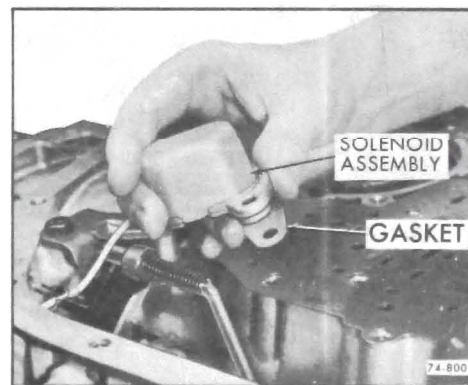

Figure 76-524

7. Remove valve body assembly, spacer plate, and gasket. See Figure 76-525.

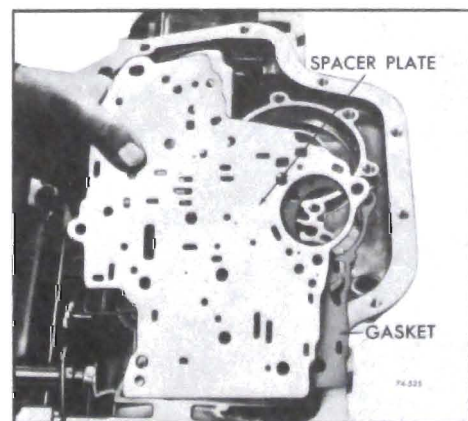

Figure 76-525

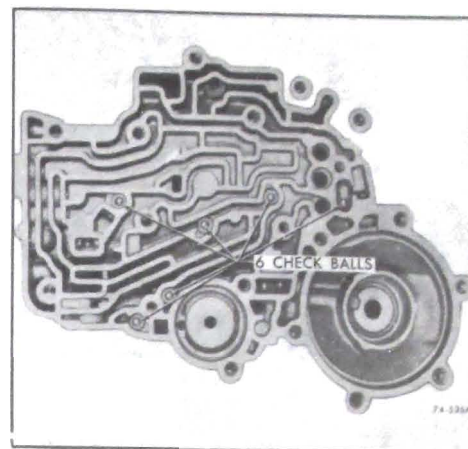

Figure 76-526

8. Remove six (6) check balls from cored passages in transmission case. See Figure 76-526.

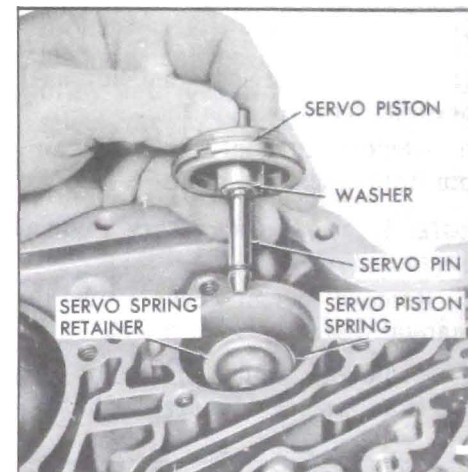

Figure 76-527

9. Remove front servo piston, washer, servo pin, retainer, and spring from transmission. See Figure 76-527.

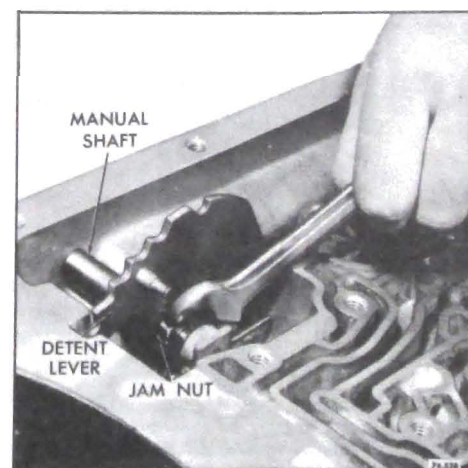

Figure 76-528

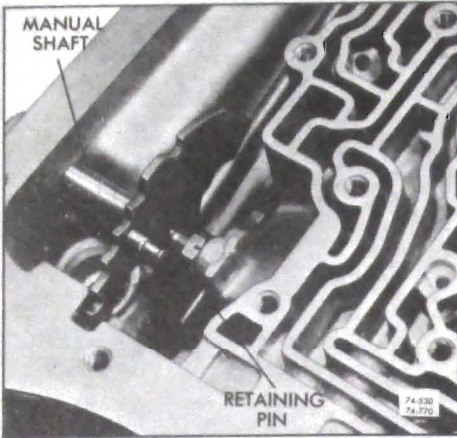

Figure 76-529

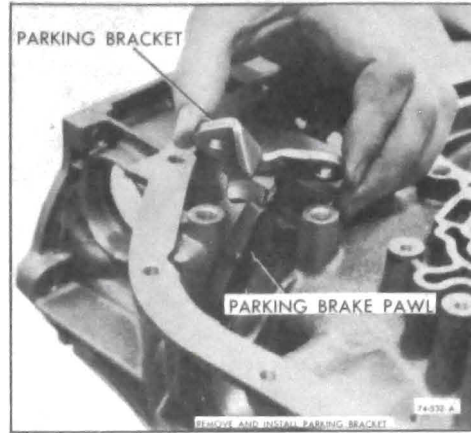

Figure 76-531

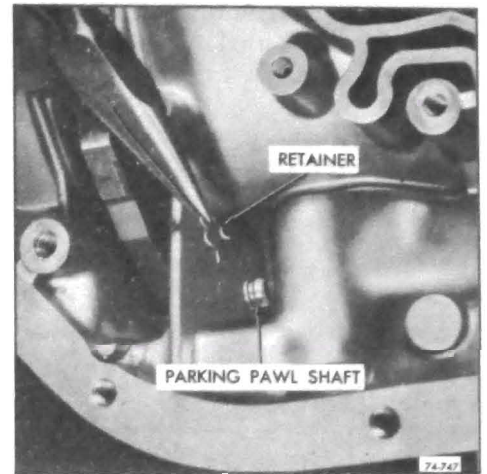

Figure 76-533

10. If it becomes necessary to remove the internal manual linkage proceed as follows:

a. Unthread jam nut holding detent lever to manual shaft. See Figure 76-528.

**CAUTION:** Do not lose jam nut as it becomes free from shaft.

b. Remove manual shaft retaining pin from case. See Figure 76-529.

**NOTE:** It may be necessary to bend pin to remove.

c. Remove detent lever from the manual shaft.

d. Remove manual shaft and jam nut from case. See Figure 76-530.

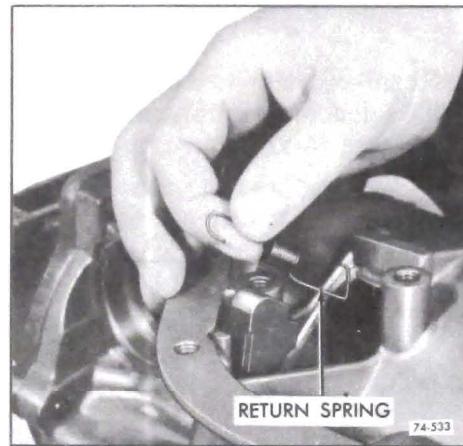

Figure 76-532

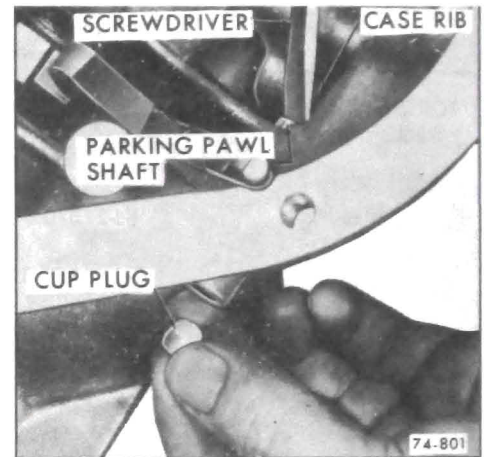

Figure 76-534

**NOTE:** If necessary remove manual shaft to case lip seal.

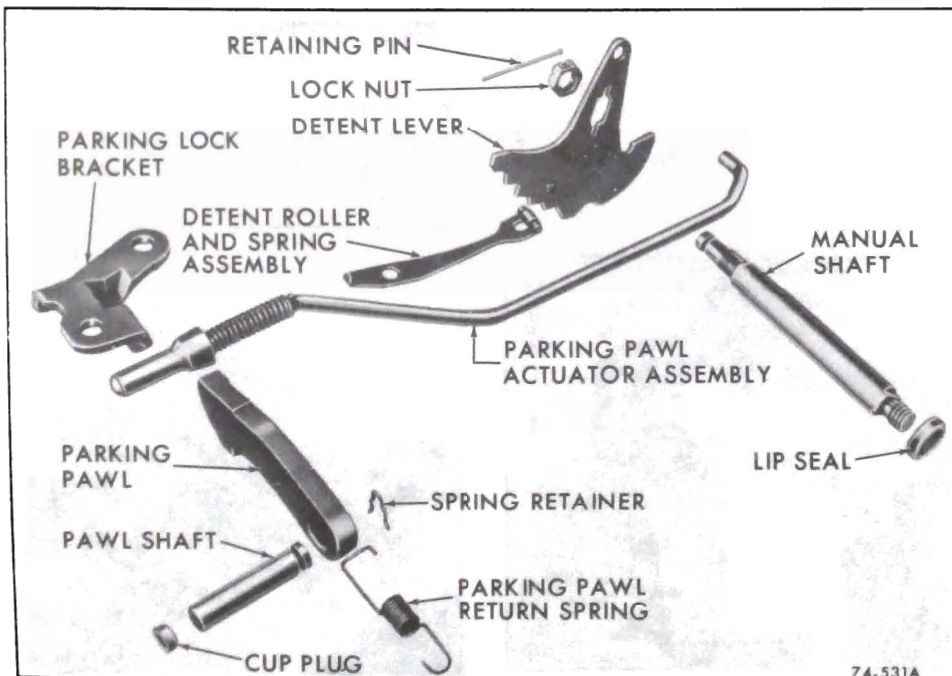

Figure 76-530

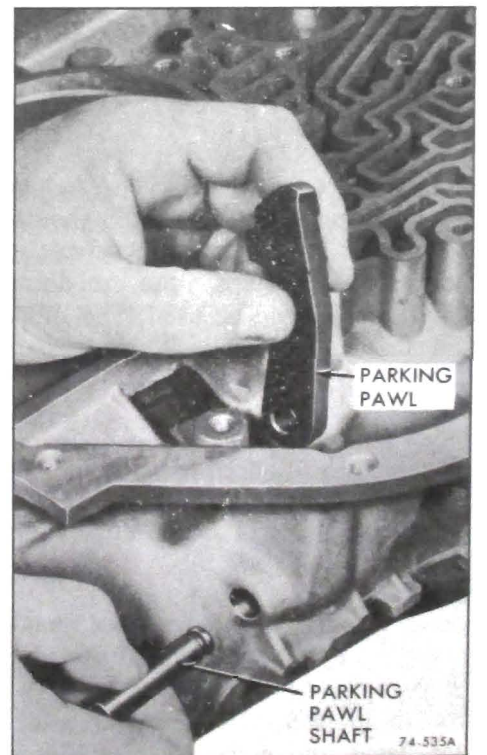

Figure 76-535

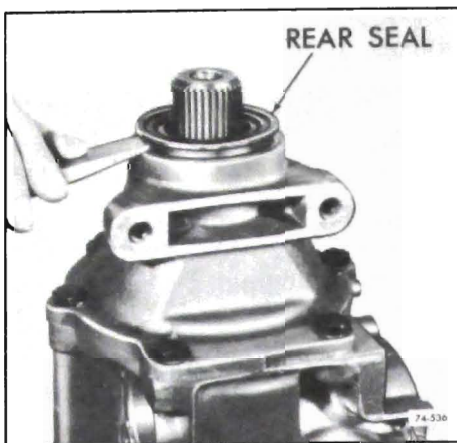

Figure 76-536

e. Remove parking pawl actuator rod and detent lever assembly.

f. Remove attaching bolts and parking lock bracket. See Figure 76-531.

g. Remove parking pawl return spring. See Figure 76-532.

**NOTE:** The following steps are to be completed only if one or more of the parts involved require replacement.

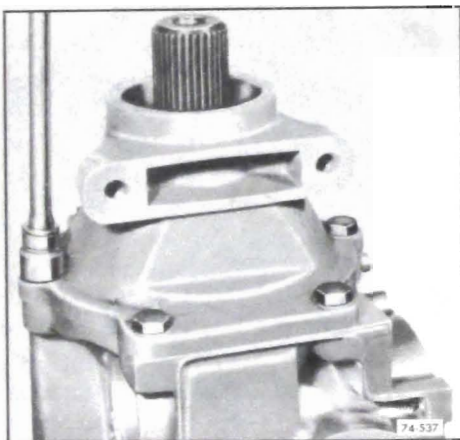

Figure 76-537

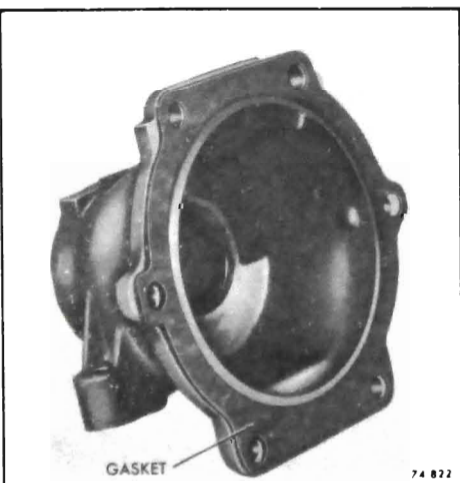

Figure 76-538

h. Remove parking pawl shaft retainer. See Figure 76-533.

i. Remove parking pawl shaft cup plug by inserting a screwdriver between the parking pawl shaft and the case rib, and prying outward. See Figure 76-534.

j. Remove parking pawl shaft, and parking pawl. See Figure 76-535.

### 76-13 REMOVAL OF REAR OIL SEAL AND EXTENSION HOUSING

1. If necessary to replace, pry the rear oil seal from the extension housing. See Figure 76-536.

2. Remove extension housing to case attaching bolts. See Figure 76-537.

3. Remove extension housing and extension housing to case gasket. See Figure 76-538.

4. Check front unit end play as follows:

a. Remove one front pump attaching bolt.

b. Install a 5/16-18 threaded slide hammer bolt or J-7004, into bolt hole in pump. See Figure 76-540.

c. Mount dial indicator on the rod and index indicator to register with end of turbine shaft. See Figure 76-540.

d. Push turbine shaft rearward.

e. Push output shaft forward.

f. Set dial indicator to Zero.

g. Pull turbine shaft forward.

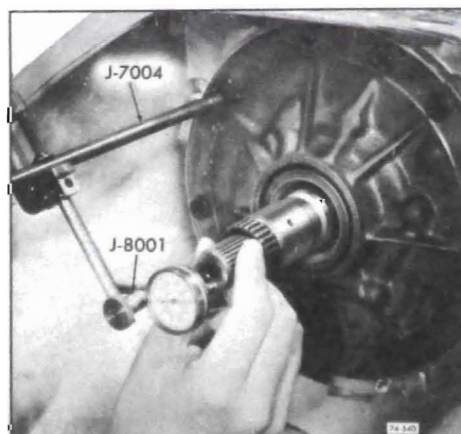

Figure 76-540

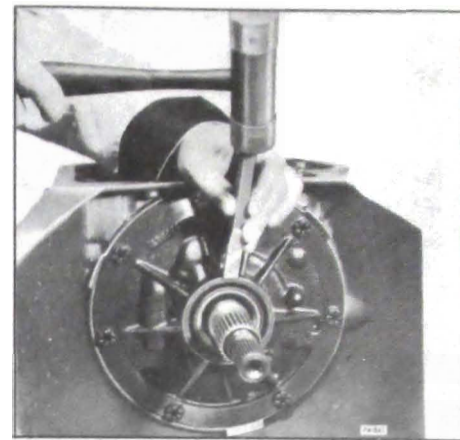

Figure 76-541

Read the resulting travel or end play which should be .003" - .024".

The selective washer controlling this end play is the washer located between the pump cover and the forward clutch housing. If more or less washer thickness is required to bring end play within specifications, select the proper washer from the chart below.

Thickness	Color
.060-.064	Yellow
.071-.075	Blue
.082-.086	Red
.093-.097	Brown
.104-.108	Green
.115-.119	Black
.126-.130	Purple

**NOTE:** An oil soaked washer may tend to discolor so that it will be necessary to measure the washer for its actual thickness.

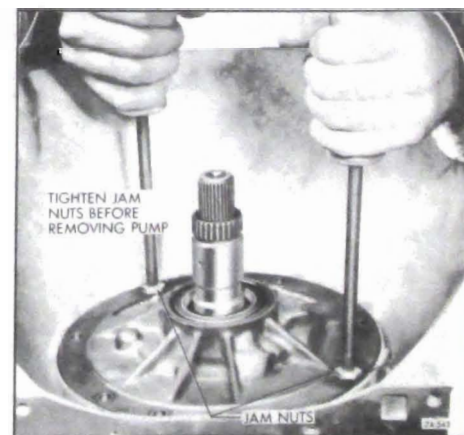

Figure 76-542



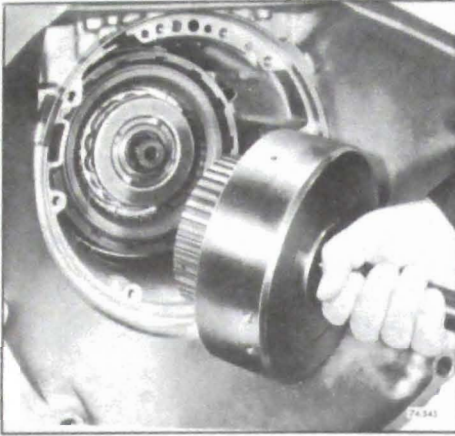

Figure 76-545

**76-14 REMOVAL OF OIL PUMP, FORWARD CLUTCH, INTERMEDIATE CLUTCH AND GEAR UNIT ASSEMBLY**

1. If seal replacement is necessary, pry seal from pump. See Figure 76-541.
2. Remove pump attaching bolts.
3. Install threaded slide Hammers, J-7004, into bolt holes in the pump body, tighten jam nuts and remove pump assembly from case. See Figure 76-542.
4. Remove and discard pump to case oil seal ring and gasket.
5. Remove forward clutch and turbine shaft assembly from transmission. See Figure 76-545.
6. Remove forward clutch hub to direct clutch housing thrust washer.

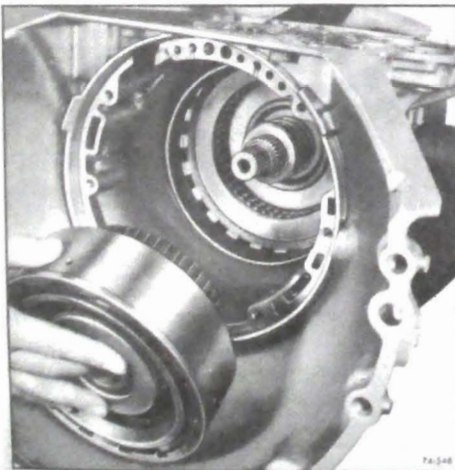

Figure 76-546

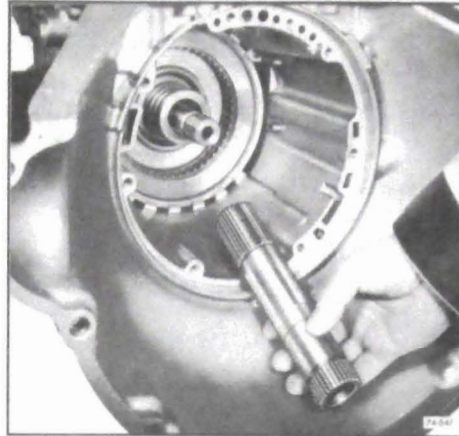

Figure 76-547

if it did not come out with forward clutch housing assembly.

7. Remove direct clutch assembly. See Figure 76-546.
8. Remove front band assembly.

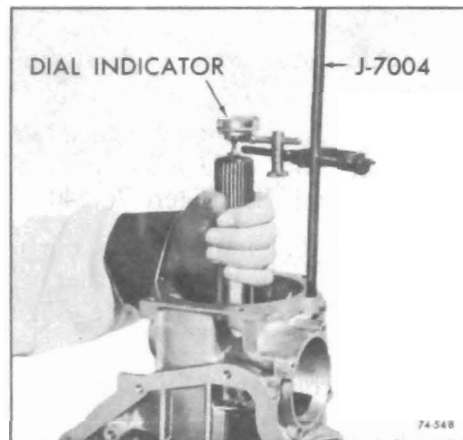

Figure 76-548

9. Remove sun gear shaft. See Figure 76-547.

10. Check rear end play as follows:  
a. Install J-7004 into an extension housing attaching bolt hole.

b. Mount dial indicator, on Slide Hammer Bolt J-7004 and index with end of the output shaft. See Figure 76-548.

c. Move output shaft in and out to determine end play. End play should be from .003" - .019". The selective washer controlling this end play is the steel washer having 3 lugs that is located between the thrust washer and the rear face of the transmission case.

If different washer thickness is required to bring the end play within specification, it can be selected from the following chart.

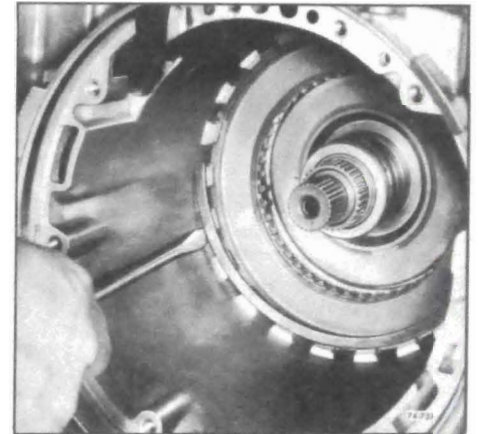

Figure 76-550

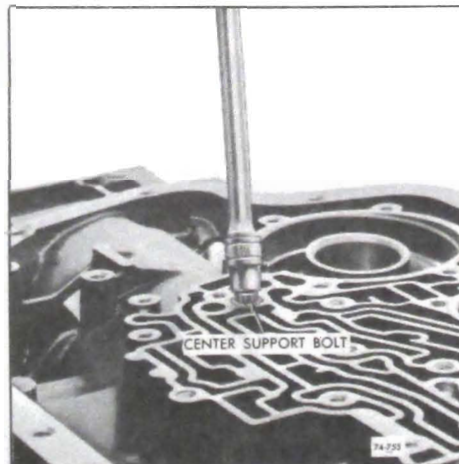

Figure 76-549

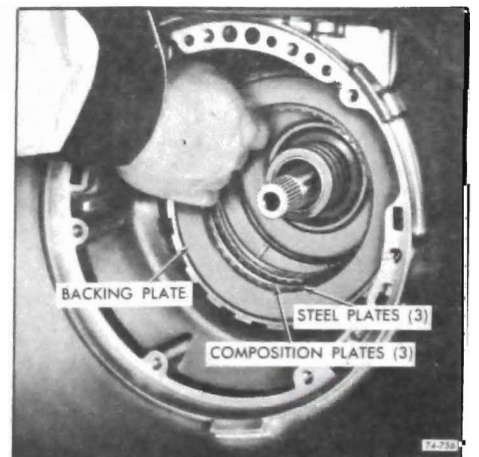

Figure 76-551

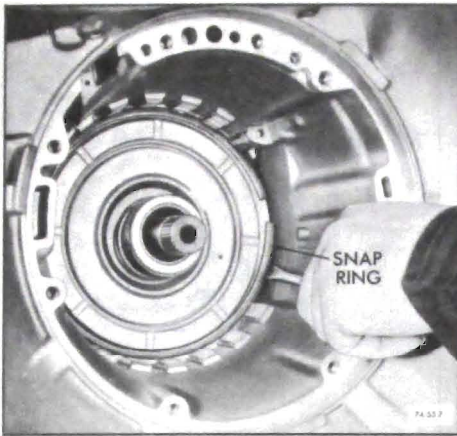

Figure 76-552

Thickness	Notches and/or Numeral	
.074-.078	None	1
.082-.086	1 Tab Side	2
.090-.094	2 Tabs Side	3
.098-.102	1 Tab O.D.	4
.106-.110	2 Tabs O.D.	5
.114-.118	3 Tabs O.D.	6

Remove case center support to case bolt using a 3/8" 12 point thin wall deep socket. See Figure 76-549.

12. Remove intermediate clutch backing plate to case snap ring. See Figure 76-550.

13. Remove intermediate clutch backing plate, 3 composition and 3 steel clutch plates. See Figure 76-551.

14. Remove center support to case retaining snap ring. See Figure 76-552.

15. Remove entire gear unit assembly by lifting with J-21795 and J-7004 Slide Hammer. See Figure 76-553.

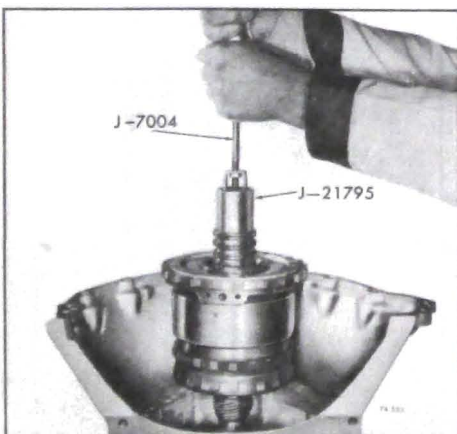

Figure 76-553

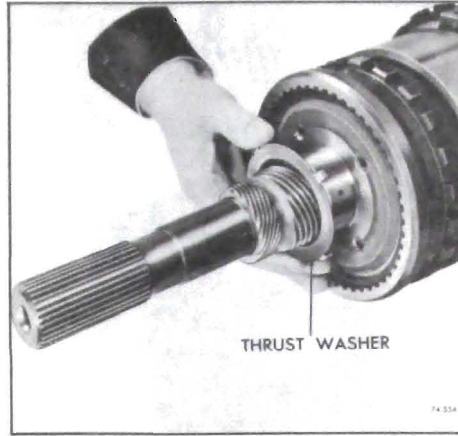

Figure 76-554

16. Remove output shaft to case thrust washer from rear of the output shaft or inside case. See Figure 76-554.

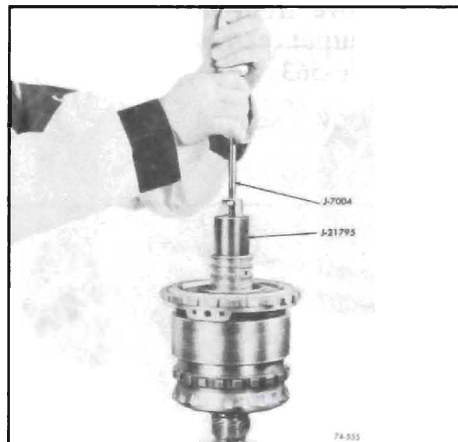

Figure 76-555

17. On Models "BA", "BU", "BC", "BB" and "BW" remove output shaft to yoke "O" ring if required.

18. Place gear unit assembly with output shaft facing down in hole in work bench. See Figure 76-555.



Figure 76-556

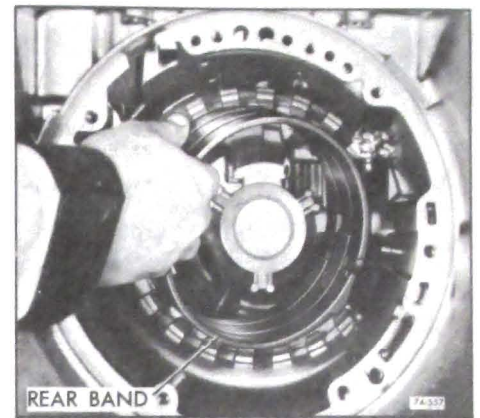

Figure 76-557

19. Remove rear unit selective washer from the transmission case. See Figure 76-556.

20. Place gear unit assembly with output shaft facing down in hole in work bench. See Figure 76-555.

21. Remove rear unit selective washer from the transmission case. See Figure 76-556.

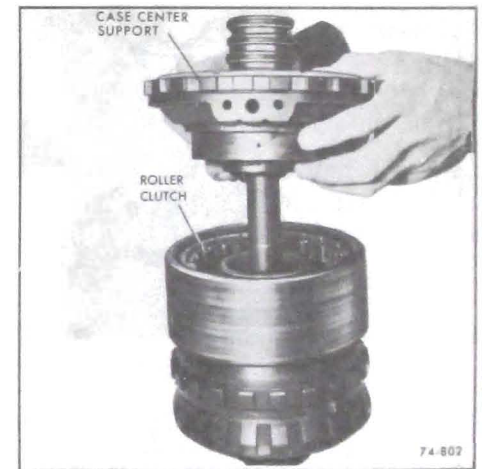

Figure 76-558

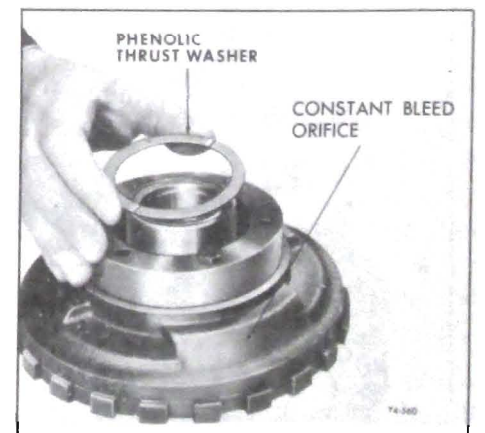

Figure 76-560

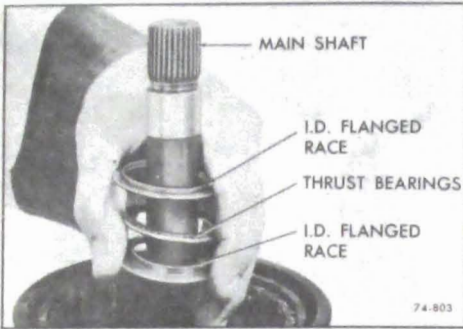

Figure 76-561

20. Remove rear band assembly. See Figure 76-557.

**76-15 GEAR UNIT ASSEMBLY**

**a. Disassembly**

1. Remove case center support assembly. See Figure 76-558.

2. Remove center support to reaction carrier thrust washer. See Figure 76-560.

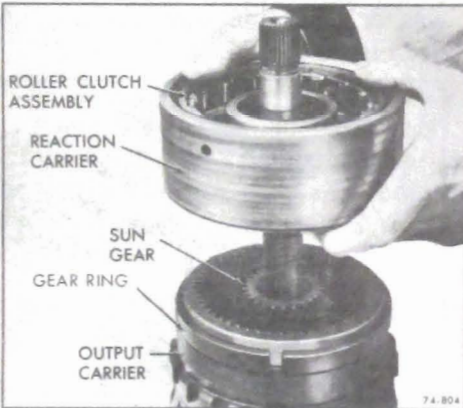

Figure 76-562

3. Remove center support to sun gear races and thrust bearing. See Figure 76-561.

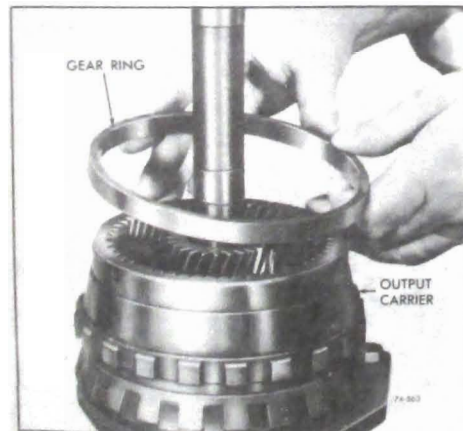

Figure 76-563



Figure 76-564

**NOTE: One of races may have been removed with the center support.**

4. Remove reaction carrier and roller clutch assembly. See Figure 76-562.

5. Remove front internal gear ring from output carrier assembly. See Figure 76-563.

6. Remove sun gear. See Figure 76-564.

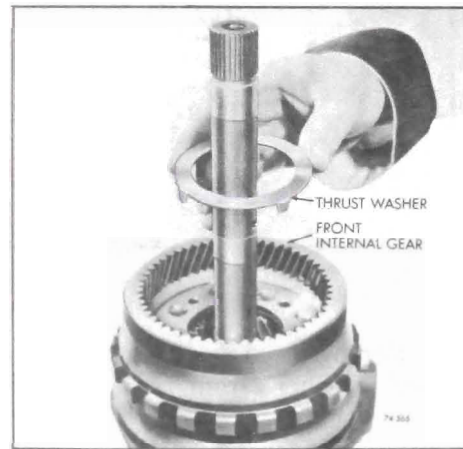

Figure 76-565

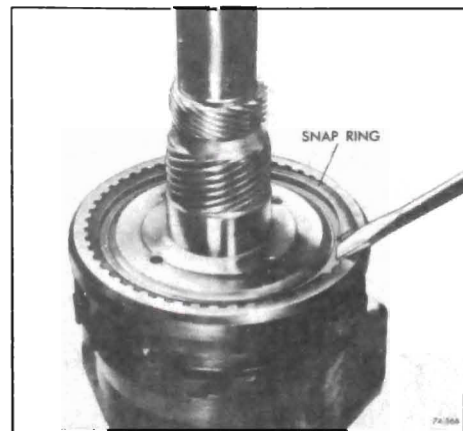

Figure 76-566

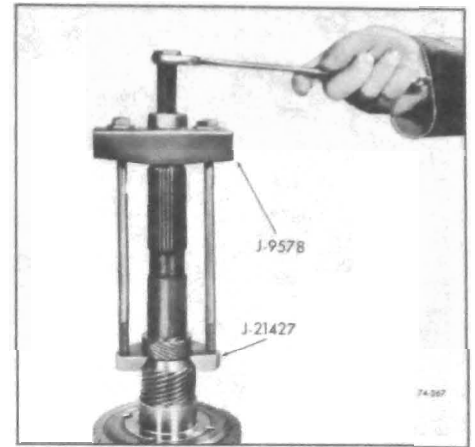

Figure 76-567

7. Remove reaction carrier to output carrier thrust washer. See Figure 76-565.

8. Turn assembly over and place mainshaft through hole in work bench.

9. Remove output shaft to rear carrier snap ring. See Figure 76-566.

10. Remove output shaft.

**NOTE: If replacement of the speedometer drive gear is necessary remove in the following manner.**

a. *Steel Speedometer Gear:* Install steel Speedometer Gear Removing Tool J-21427 and J-9578, on output shaft and remove speedometer drive gear. See Figure 76-567.

b. Install new steel speedometer drive gear. Press to 5-5/8" for "BA", "BB" models, and 11-7/16" for "BC".

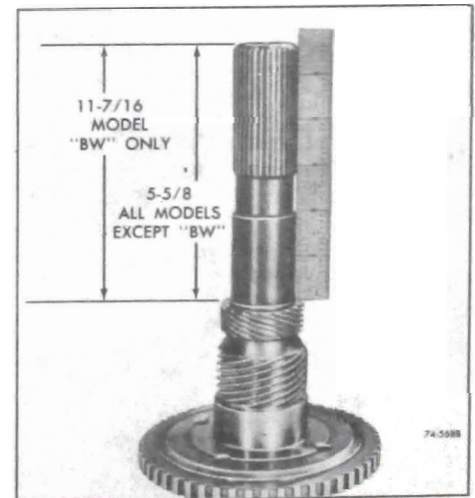

Figure 76-568

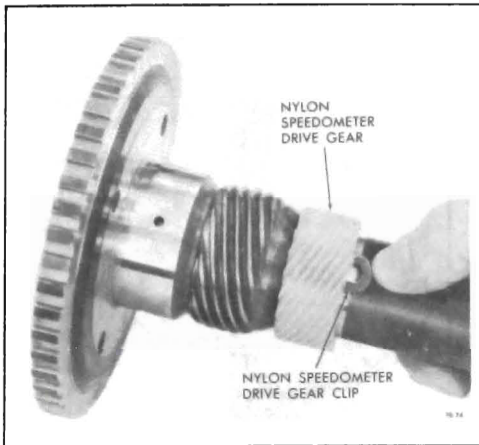

Figure 76-569

"BU, and "BW" models. See Figure 76-568.

c. *Nylon Speedometer Drive Gear:* Depress retaining clip and slide nylon gear off output shaft. See figure 76-569.

d. To install, place retaining clip (square and toward flange of shaft) into hole in output shaft. (See Figure 76-569) Align slot in speedometer drive gear with retaining clip and install gear.

**NOTE:** The nylon speedometer drive gear is installed at the factory only. All service replacement gears are steel. When a service gear is required, discard the retaining clip and proceed as described in step b above.

11. Remove output shaft to rear internal gear thrust bearing and two (2) races. See Figure 76-570.

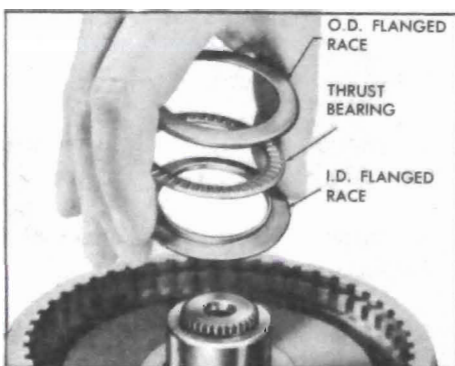

Figure 76-570



Figure 76-571

12. Remove rear internal gear and mainshaft. See Figure 76-571.

**NOTE:** Do not drop bearings.

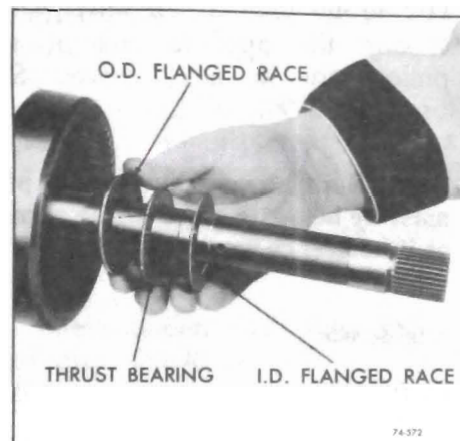

Figure 76-572

13. Remove rear internal gear to sun gear thrust bearing and two (2) races. See Figure 76-572.

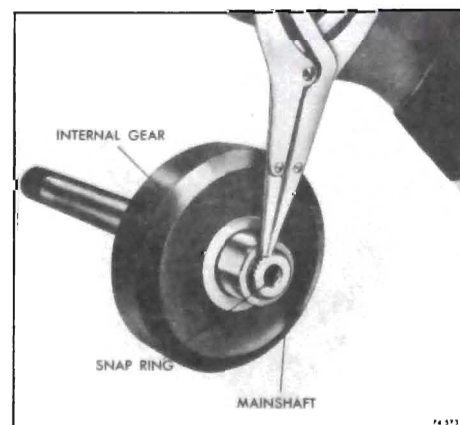

Figure 76-573

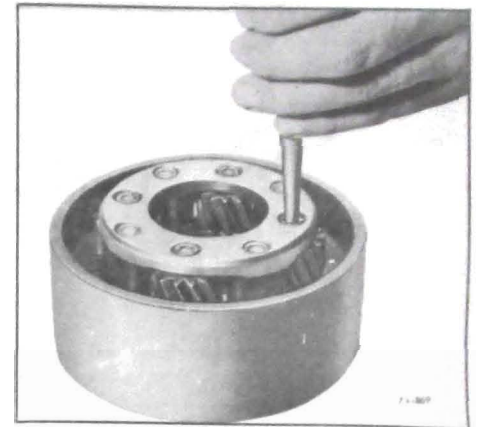

Figure 76-574

14. To remove mainshaft, remove the rear internal gear to mainshaft snap ring. See Figure 76-573.

#### b. Pinion Replacement Procedure

1. Support carrier assembly on its front face.

2. Using a 1/2 inch diameter drill, remove the stake marks from the end of the pinion pin, or pins, to be replaced. This will reduce the probability of cracking the carrier when pinion pins are pressed out.

**CAUTION:** Do not allow drill to remove any stock from the carrier, as this will weaken the part and future failure would be probable.

3. Using a tapered punch, drive or press the pinions out of the carrier. See Figure 76-574.

4. Remove pinions, thrust washers and needle roller bearings.

5. Inspect pinion pocket thrust faces for burrs and remove if present.

6. Install eighteen (18) needle bearings into each pinion, using petroleum jelly to hold the bearings in place. Use a pinion pin as a guide. See Figure 76-575.

7. Place a bronze and steel thrust washer on each side of pinion so steel washer is against pinion, hold them in place with petroleum jelly.

8. Place pinion assembly in position in the carrier and install a pilot shaft through the rear face of the assembly to hold the parts in place.

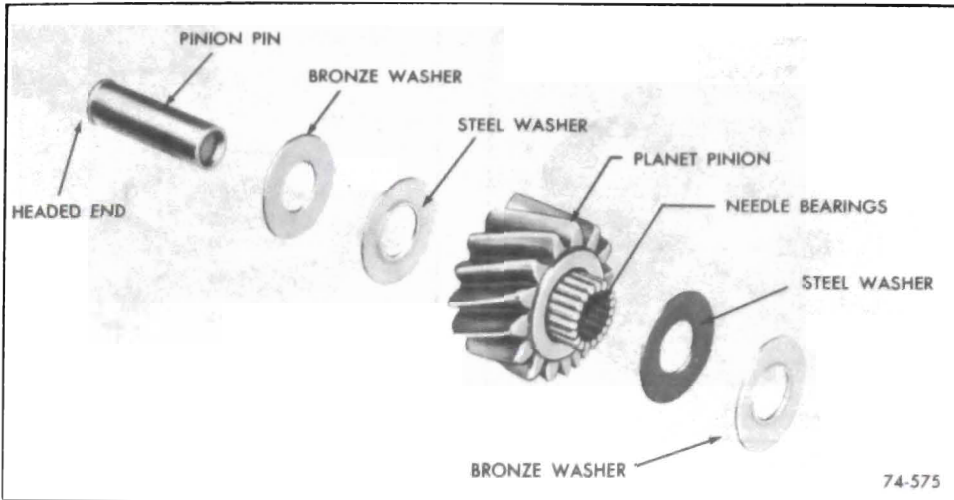

Figure 76-575

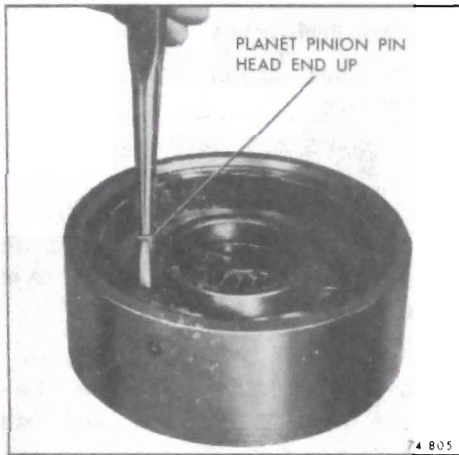

Figure 76-576

9. Drive a new pinion pin into place while rotating pinion from the front, being sure that the headed end is flush or below the face of the carrier. See Figure 76-576.



Figure 76-577

10. Place a large punch in a bench vise to be used as an anvil while staking the opposite end of the pinion pin in three places. See Figure 76-577.

**NOTE:** Both ends of the pinion pins must lie below the face of the carrier or interference may occur.

**c. Inspection**

*Output Shaft*

1. Inspect bushing for wear or galling. If replacement is necessary proceed as follows:

a. Thread Tool J-21465-16 into bushing using Slide Hammer J-2619, remove. See Figure 76-578.

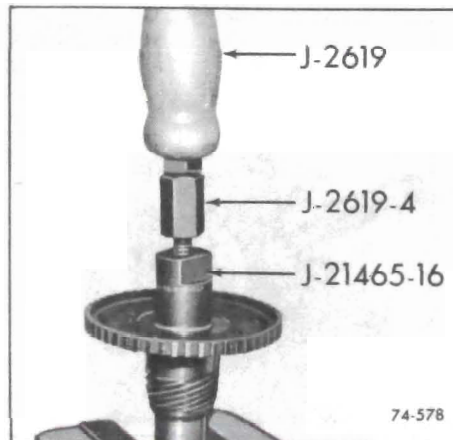

Figure 76-578

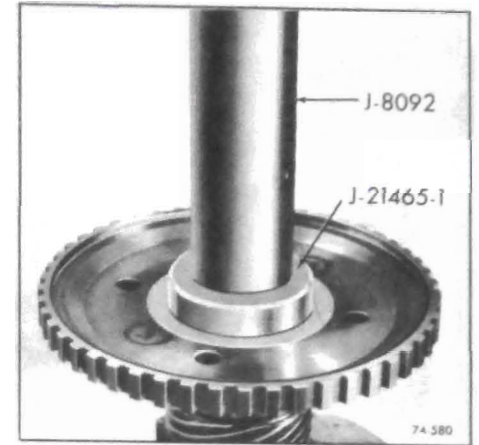

Figure 76-580

b. Using Tool J-21465-1 install bushing. See Figure 76-580.

2. Inspect bearing and thrust washer surfaces for damage.

3. Inspect governor drive gear for rough or damaged teeth.

4. Inspect splines for damage.

5. Inspect orificed cup plug in the lubrication passage.

6. Inspect drive lugs for damage.

*Inspection of Rear Internal Gear*

1. Inspect gear teeth for damage or wear.

2. Inspect splines for damage.

3. Inspect gear for cracks.

**d. Mainshaft-Inspection**

1. Inspect shaft for cracks or distortion.

2. Inspect splines for damage.

3. Inspect ground bushing journals for damage.

4. Inspect snap ring groove for damage.

5. Inspect orificed cup plug pressed into one end of mainshaft. Be sure it is not plugged and oil lubrication holes are open.

*Inspection of Sun Gear*

1. Inspect gear teeth for damage or wear.
2. Inspect splines for damage.
3. Inspect the gear for cracks.

*Inspection of Sun Gear Shaft*

1. Inspect shaft for cracks or splits.
2. Inspect splines for damage.
3. Inspect bushings for scoring or galling. If replacement is necessary proceed as follows:

a. Thread J-21465-15 into Sun Gear Shaft. Thread Slide Hammer J-2619 into remover. Clamp slide hammer handle into vise. Grasp sun gear shaft and remove bushing.

b. Using Installer J-21465-5 and Drive Handle 8092, install new bushing.

**NOTE:** This procedure applies to bushings in both ends of shaft.

4. Inspect ground bushing journals for damage.
5. Be sure the oil lubrication hole is open.

*Inspection of reaction Carrier, Roller Clutch and Output Carrier Assembly*

1. Inspect band surface on reaction carrier for signs of burning or scoring.

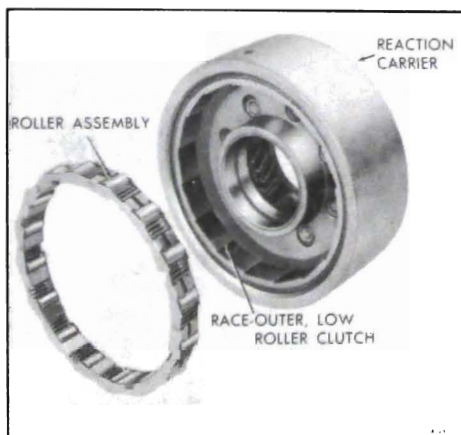

Figure 76-581

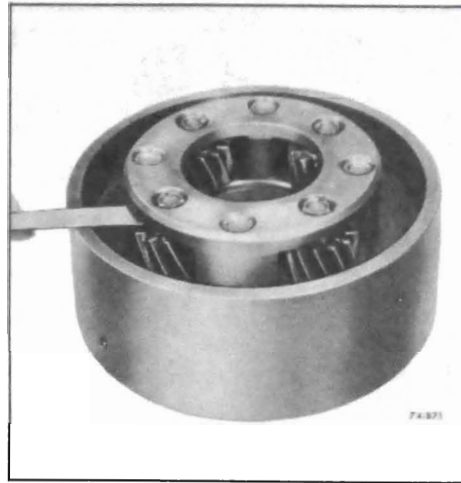

Figure 76-582

2. Inspect roller clutch outer race for scoring or wear. See Figure 76-581.
3. Inspect thrust washer surfaces for signs of scoring or wear.
4. Inspect bushing for damage. If bushing is damaged the reaction carrier must be replaced.
5. Inspect pinions for damage, rough bearings or excessive tilt.
6. Check pinion end play. Pinion end play should be .009" - .024". See Figure 76-582.
7. Inspect roller clutch for damaged members.
8. Inspect roller cage and retaining springs for damage.



Figure 76-583

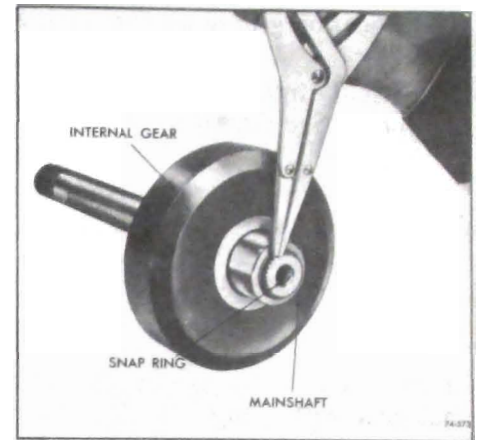

Figure 76-584

9. Inspect front internal gear for damaged teeth.
  10. Inspect pinions for damage, rough bearings or excessive tilt.
  11. Check pinion end play. Pinion end play should be .009" - .024". See Figure 76-583.
  12. Inspect parking pawl lugs for cracks or damage.
  13. Inspect output locating splines for damage.
  14. Inspect front internal gear ring for flaking or cracks.
- e. *Installation* 1. Install rear internal gear on end of mainshaft having snap ring groove.

**NOTE:** Make certain mainshaft has

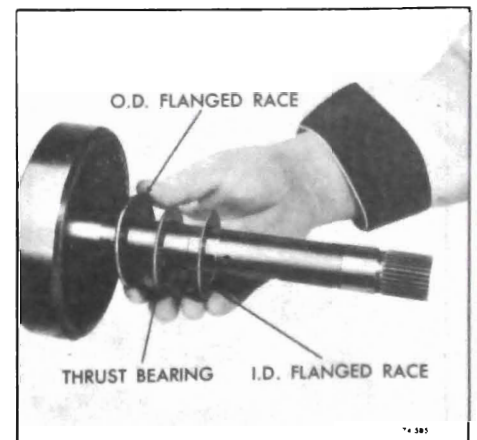

Figure 76-585

identification groove on rear of journal.

2. Install internal gear retaining snap ring. See Figure 76-584.

3. Install sun gear to internal gear thrust races and bearings against the inner face of the rear internal gear as follows: and retain with petroleum jelly. See Figure 76-585.

a. Place large race against the internal gear with flange facing forward or up.

b. Place thrust bearing against race.

c. Place small race against bearing with inner flange facing into the bearing or down.

4. Install output carrier over the mainshaft so that the pinions mesh with rear internal gear.

5. Place above portion of "build-up" through hole in bench so that mainshaft hangs downward.

6. Install rear internal gear to output shaft thrust races and bearing as follows; and retain with petroleum jelly. See Figure 76-586.

a. Place small diameter race against internal gear with center flange facing up.

b. Place bearing on race.

c. Place second race on bearing with outer flange cupped over bearing.

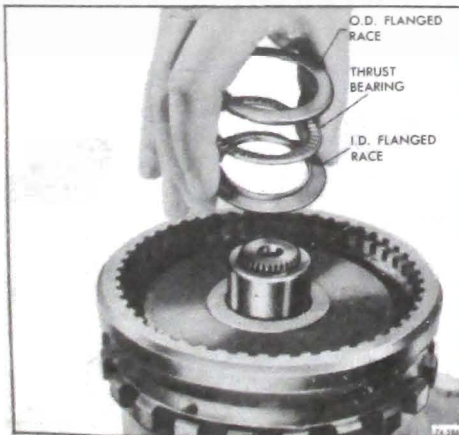

Figure 76-586

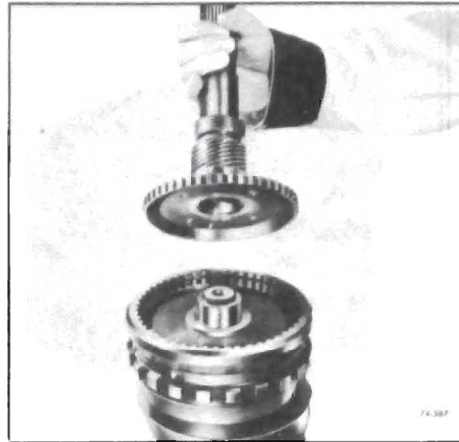

Figure 76-587

7. Install output shaft into output carrier assembly. See Figure 76-587.

8. Install output shaft to output carrier snap ring. See Figure 76-588.

**CAUTION:** The 1969 output shaft to output carrier snap ring is flat and thinner than pre 1969 snap rings. The change in design of the 1969 snap ring required a change in the groove of the output carrier. The flat snap ring and pre 1969 snap ring (one side is beveled) are NOT interchangeable.

9. Lubricate with petroleum jelly and install output shaft to case thrust washer and turn unit over. See Figure 76-589.

10. On Models "BA", "BC", "BU", "BB" and "BW" install output to yoke "O" ring seal.



Figure 76-588

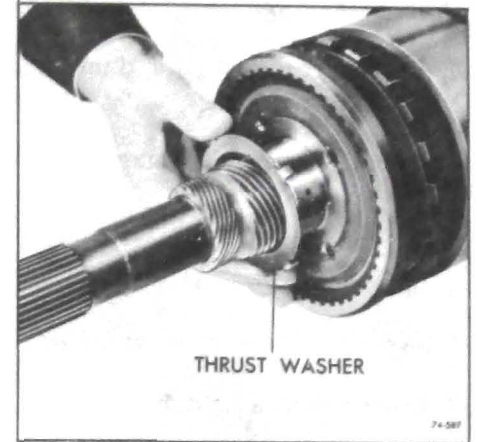

Figure 76-589

11. Lubricate with petroleum jelly and install reaction carrier to output carrier thrust washer with tabs facing down in pockets. See Figure 76-590.



Figure 76-590

12. Install sun gear splines with inner chamfer down. See Figure 76-591.

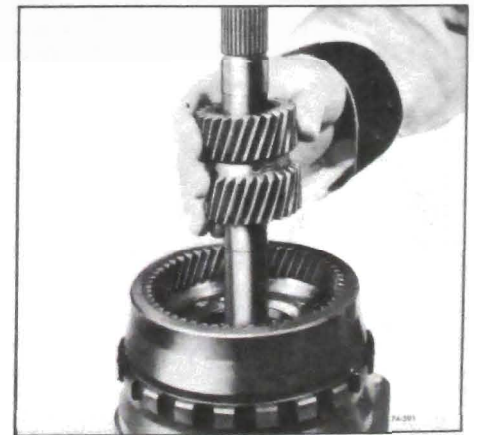

Figure 76-591

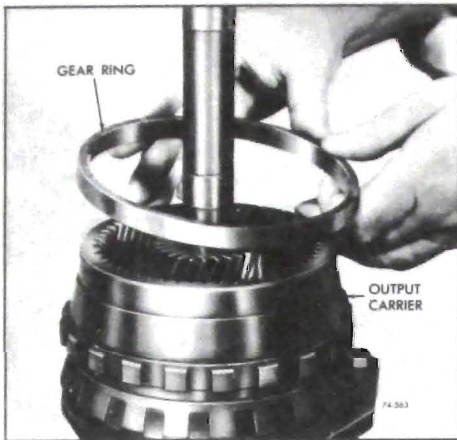

Figure 76-592

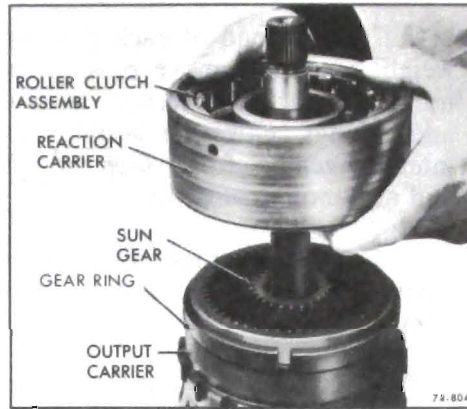

Figure 76-594

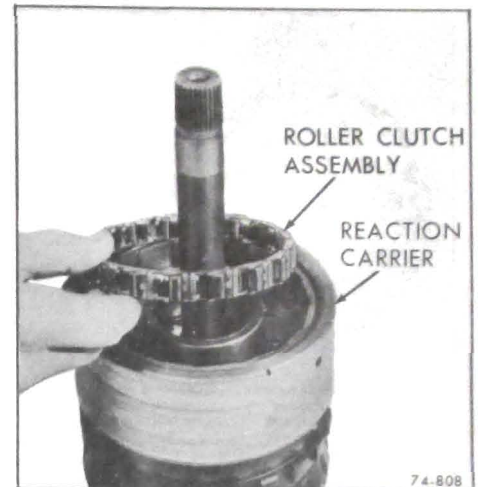

Figure 76-597

13. Install gear ring over output carrier. See Figure 76-592.

14. Install sun gear shaft.

15. Install reaction carrier. See Figure 76-593.

**NOTE:** When a new output carrier and/or reaction carrier is being installed, and if the front internal gear ring prevents assembly of the carriers, replace the front internal gear with the SERVICE ring.

16. Lubricate with petroleum jelly and install center support to sun gear thrust races and bearing as follows: See Figure 76-594.

a. Install large race, center flange up over the sun gear shaft.

b. Install thrust bearing against race.

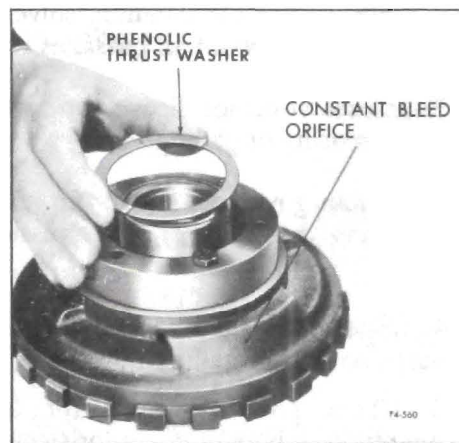

Figure 76-595

c. Install second race, center flange up.

17. Lubricate with petroleum jelly and install center support to reaction

carrier thrust washer into recess in center support. See Figure 76-595.

18. Install rollers in roller clutch cage, by compressing energizing spring with forefinger and inserting roller from outer side. See Figure 76-596.

**NOTE:** Make certain that energizing springs are not distorted, and that curved end of leaf of springs are positioned against rollers.

19. Install roller clutch assembly into reaction carrier. See Figure 76-597.

20. Install center support into roller clutch in reaction carrier. See Figure 76-598.

**NOTE:** With reaction carrier held, center support should turn counter-clockwise only. See Figure 76-599.



Figure 76-593

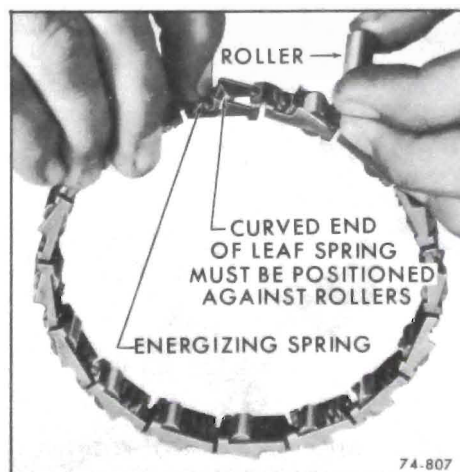

Figure 76-596

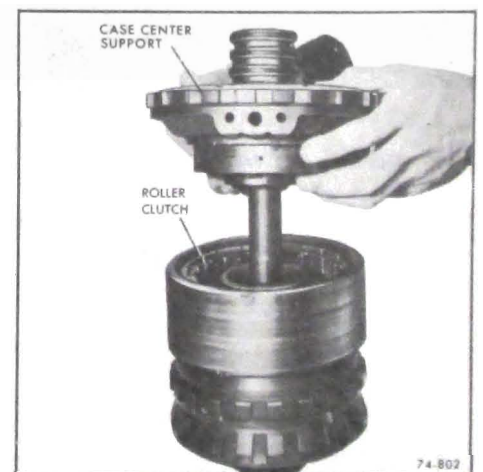

Figure 76-598



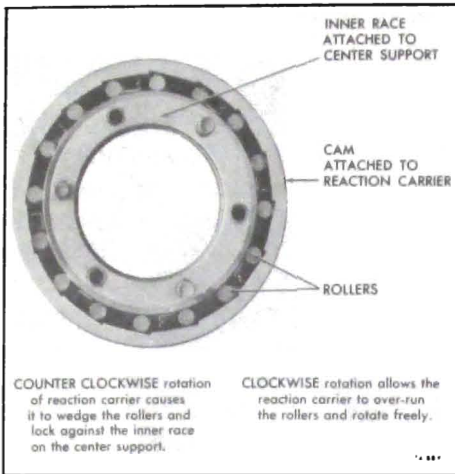

Figure 76-599

## 76-16 GOVERNOR ASSEMBLY

All components of the governor assembly, with the exception of the driven gear, are a select fit and each assembly is calibrated. The governor, including the driven gear, is serviced as a complete assembly. However, the driven gear can also be serviced separately.

It is necessary to disassemble the governor assembly in order to replace the driven gear. Disassembly may also be necessary due to foreign material causing improper operation. In such cases, proceed as follows:

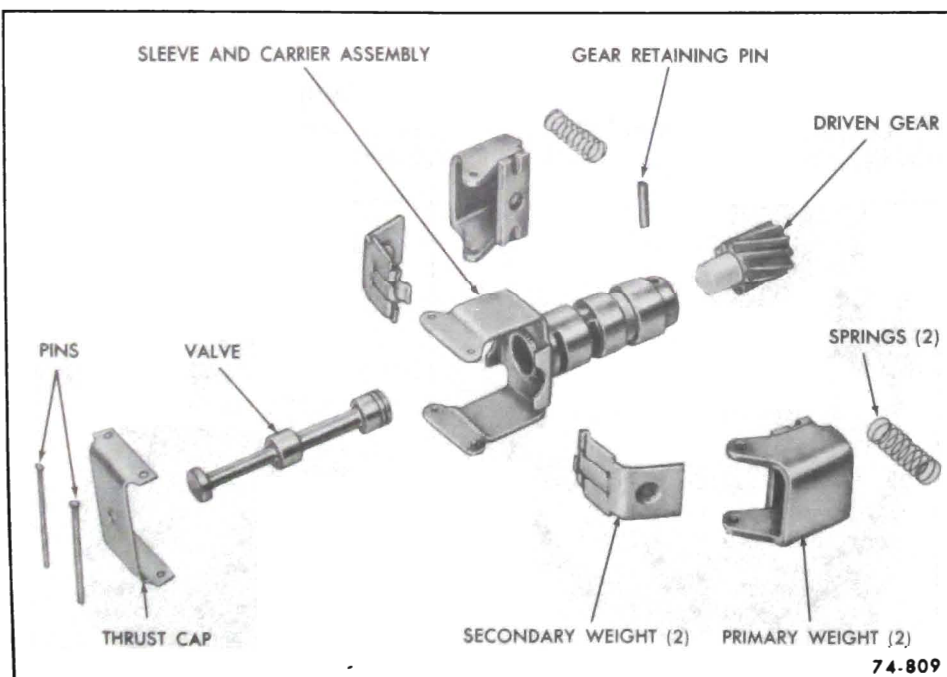

Figure 76-600

### a. Disassembly (See Figure 76-600)

1. Cut off one end of each governor weight pin and remove pins, governor thrust cap, governor weights, and springs. Governor weights are interchangeable from side to side and need not be identified.
2. Remove governor valve from governor sleeve. Be careful not to damage valve.
3. Perform the following inspections and replace governor driven gear, if necessary.

### b. Inspection

1. Wash all parts in cleaning solvent, air dry and blow out all passages.
2. Inspect governor sleeve for nicks, burrs, scoring or galling.
3. Check governor sleeve for free operation in bore of transmission case.
4. Inspect governor valve for nicks, burrs, scoring or galling.
5. Check governor valve for free operation in bore of governor sleeve.
6. Inspect governor driven gear for nicks, burrs, or damage.

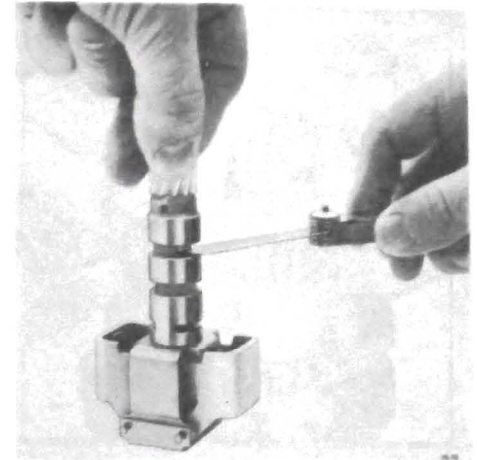

Figure 76-600A

7. Check governor driven gear for looseness on governor sleeve.
8. Inspect governor weight springs for distortion or damage.
9. Check governor weights for free operation in their retainers.
10. Check valve opening at entry (.020 inch minimum) with a feeler gage, holding governor as shown in figure 76-600A, with governor weights extended completely outward. For exhaust (.020" minimum) governor weights must be completely inward.

### c. Governor Driven Gear Replacement

To facilitate governor repair in the field, governor driven gear and replacement pins are available for service use. The service package contains a nylon driven gear, two governor weight retaining pins and one governor gear retainer split pin. Replacement of gear must be performed with care in the following manner:

1. Drive out governor gear retaining split pin using small punch or 1/8" drill rod. See Figure 76-601.
2. Support governor on 3/16 inch plates installed in exhaust slots of governor sleeve, place in press, and with a long punch, press gear out of sleeve.

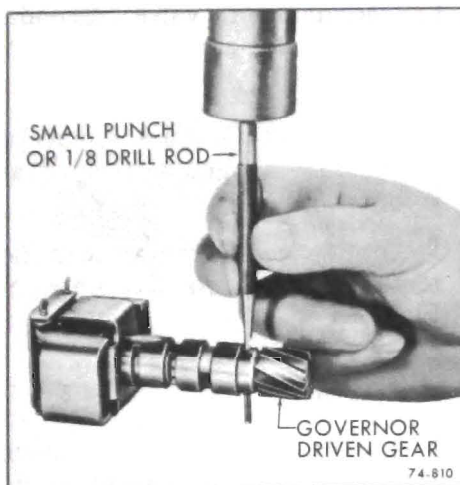

Figure 76-601

3. Carefully clean governor sleeve of chips that remain from original gear installation.

4. Support governor on 3/16 inch plates, installed in exhaust slots of sleeve, position new gear in sleeve and, with a suitable socket, press gear into sleeve until nearly seated. Carefully remove any chips that may have shaved off gear hub and press gear in until it bottoms on shoulder.

5. A new pin hole must be drilled through sleeve and gear. Locate hole position 90° from existing hole, center punch, and then while supporting governor in press, drill new hole through sleeve and gear using a standard (1/8 inch) drill.

6. Install retaining pin.

7. Wash governor assembly thoroughly to remove any chips that may have collected.

#### d. Assembly (See Figure 76-600)

1. Install governor valve in bore of governor sleeve.

2. Install governor weights and springs, and thrust cap on governor sleeve.

3. Align pin holes in thrust cap, governor weight assemblies and governor sleeve, and install new pins. Crimp both ends of pin to prevent them from falling out.

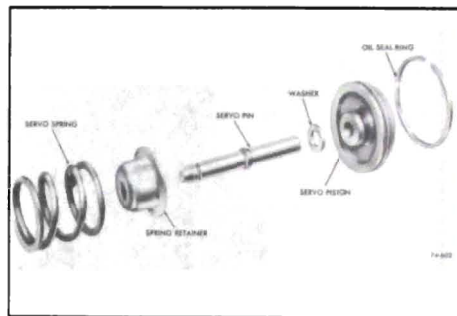

Figure 76-602

4. Check governor weight assemblies for free operation on pins and governor valve for free operation in governor sleeve.

### 76-17 FRONT SERVO INSPECTION

1. Inspect servo pin for scores and cracks. See Figure 76-602.

2. Inspect piston for damaged oil ring groove, check freedom of ring in groove.

3. Inspect piston for cracks or porosity.

4. Check fit of servo pin in piston.

### 76-18 REAR SERVO ASSEMBLY

#### a. Disassembly

1. Remove rear accumulator piston from rear servo piston.

2. Remove "E" ring retaining rear servo piston to band apply pin. See Figure 76-603.

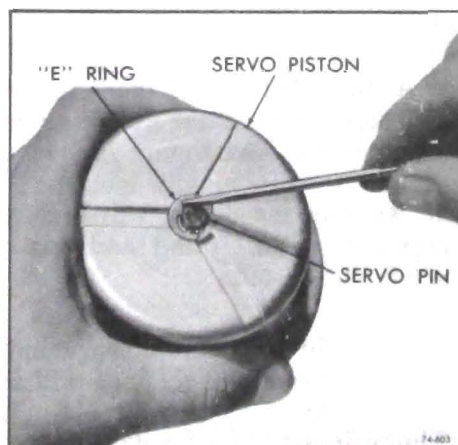

Figure 76-603



Figure 76-604

3. Remove rear servo piston and seal from band apply pin. See Figure 76-604.

#### b. Inspection

1. Inspect freedom of accumulator ring in piston.

2. Inspect fit of band apply pin in servo piston.

3. Inspect band apply pin for scores and cracks.

#### c. Reassembly

1. Install spring retainer, spring and washer on band apply pin. See Figure 76-605.

**NOTE: If new pin is required, install here.**

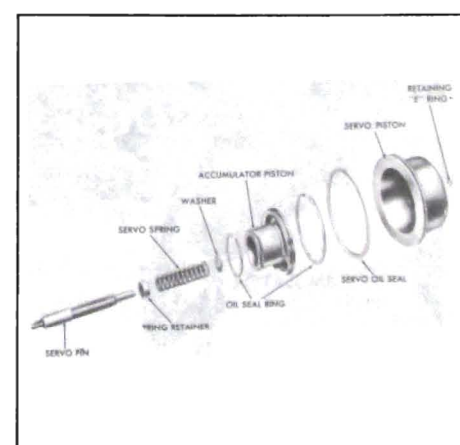

Figure 76-605

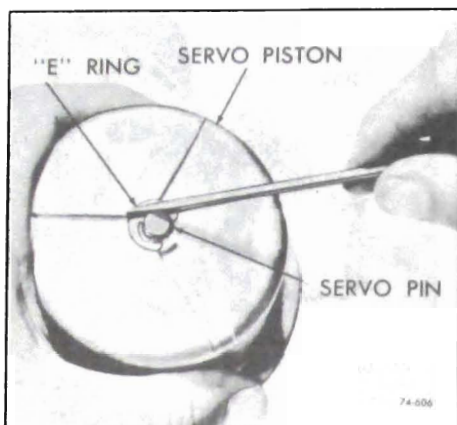

Figure 76-606

2. Install band apply pin retainer, spring and washer into bore of servo piston and secure with "E" ring. See Figure 76-606.

3. Install oil seal ring on servo piston, if removed.

4. Install outer and inner oil rings on accumulator piston, if removed, and assemble into bore of servo piston.

## 76-19 VALVE BODY ASSEMBLY

### a. Disassembly

1. Position valve body assembly with cored face up and servo pocket nearest operator.

2. Remove manual valve from upper bore.

3. Install special Tool J-21885 on

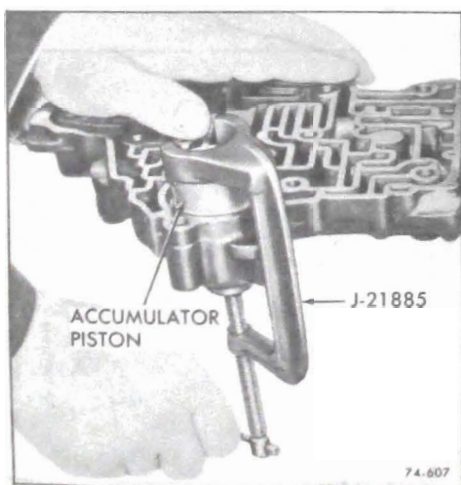

Figure 76-607



Figure 76-608

accumulator piston and remove retaining "E" ring. See Figure 76-607.

4. Remove front accumulator piston and spring. See Figure 76-608.

5. On the right side, top bore, remove the retaining pin, 1-2 modulator bushing, 1-2 regulator valve, and 1-2 regulator spring. See Figure 76-614.

6. Remove the 1-2 detent valve and 1-2 valve. See Figure 76-614.

7. From the next bore down, remove the retaining pin; 2-3 modulator bushing and 2-3 modulator valve spring, 2-3 modulator valve, 3-2 intermediate spring and the 2-3 valve. See Figure 76-614.

8. From the next bore down, remove the retaining roll pin, bore plug, spacer, spring and 3-2 valve. See Figure 76-614.

9. At the other end of the assembly, top bore, remove the retaining pin and bore plug. See Figure 76-614.

10. Remove the detent valve, detent regulator valve, spring and spacer. See Figure 76-614.

11. From the next bore down, remove the 1-2 accumulator retainer pin, and the 1-2 accumulator valve plug. See Figure 76-614.

12. Remove 1-2 accumulator bushing,

1-2 accumulator valve secondary spring, and 1-2 accumulator secondary valve.

13. From the same bore, remove the primary 1-2 accumulator valve and spring.

14. From the Governor feed hole remove the screen assembly. See Figure 76-611.

### b. Inspection

1. Inspect all valves for scoring, cracks and free movement in their respective bores.

2. Inspect the body for cracks, scored bores, interconnected oil passages and flatness of mounting face.

3. Check all springs for distortion or collapsed coils.

4. Clean governor oil screen in clean solvent and air dry.

### c. Reassembly

1. Install front accumulator spring and piston into valve body.

2. Install special Tool J-21885 and compress spring and piston. Secure with retaining "E" ring. See Figure 76-612.

**NOTE: Align piston and ring when entering bore.**

3. Install the 1-2 primary spring and the 1-2 primary valve into bore using a retainer pin as a retractor to hold the spring and valve in its operating position until bushing and 1-2 accumulator valve and spring are installed.

4. Install the 1-2 accumulator secondary valve (wide land first) into the 1-2 accumulator bushing. See Figure 76-614.

5. Install the 1-2 accumulator valve bushing into the bore.

6. Install the 1-2 accumulator valve secondary spring and 1-2 accumulator plug into the bushing. See Figure 76-614.

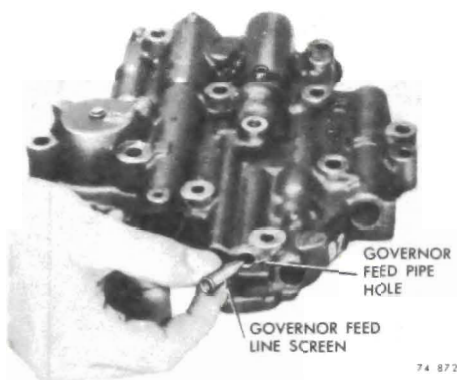

Figure 76-611

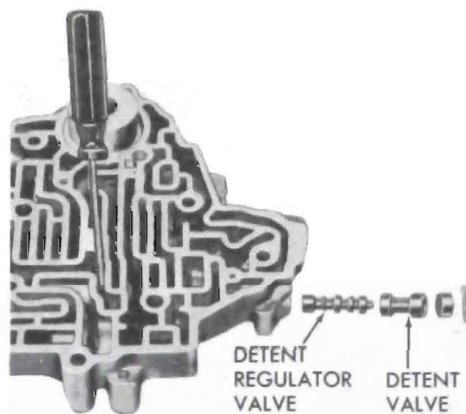

Figure 76-613

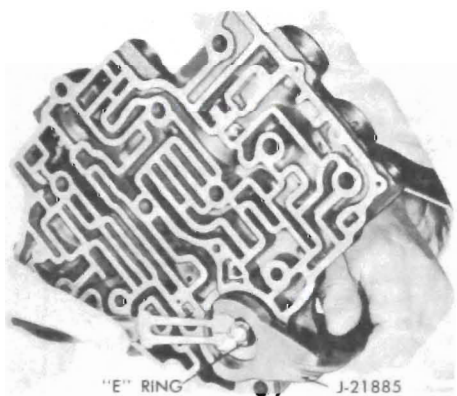

Figure 76-612

7. Install grooved retaining pin from cast surface side of valve body with grooves entering the pin hole last. Tap pin with hammer until flush with cast surface. Remove the retainer pin which was used to hold the 1-2 primary valve and spring in their operation position.

8. In the next bore up, install the detent spring and spacer. Compress spring and secure with small screwdriver. See Figure 76-613.

9. Install the detent regulator valve. Wide land first. See Figure 76-613.

10. Install the detent valve, narrow land first. See Figure 76-613.

11. Remove the screwdriver as the bore plug (hole out) and retaining pin are installed. See Figure 76-613.

12. In the lower right hand bore, install the 3-2 valve. See Figure 76-614.

13. Install the spacer, spring bore plug (hole out) and retaining pin. See Figure 76-614.

14. In the next bore up, install the 2-3 valve, stem end out, and 3-2 intermediate spring. See Figure 76-614.

15. Install the 2-3 modulator valve into bushing. See Figure 76-614.

16. Install the 2-3 modulator valve and bushing, into valve body bore. See Figure 76-614.

17. Install the 2-3 valve spring, compress spring and install retaining pin.

18. In the next bore, install the 1-2 valve, stem end out. See Figure 76-614.

19. Install the 1-2 regulator valve, spring and detent valve, into the bushing, aligning spring in bore of detent valve, and install parts into the valve bore. See Figure 76-614.

20. Compress the bushing against the spring and install the retaining pin. See Figure 76-614.

21. Install governor oil screen assembly into governor oil feed hole, pinched end first. See Figure 76-611.

**NOTE:** Screen is held in place by the governor feed pipe when installed on transmission case.

22. Install the manual valve with detent pin groove to the right. See Figure 76-614.

## 76-20 OIL PUMP ASSEMBLY

### a. Disassembly

1. Place pump assembly through hole in bench.

2. Compress the regulator boost valve bushing against the pressure regulator spring and remove the snap ring using J-5403 pliers. See Figure 76-615.

3. Remove the regulator boost valve bushing and valve.

4. Remove the pressure regulator spring.

5. Remove the regulator valve, spring retainer and spacer(s), if present. See Figure 76-616.

6. Remove the pump cover to body attaching bolts. See Figure 76-617.

7. Remove pump cover from body. See Figure 76-623.

8. Remove the retaining pin and bore plug from the pressure regulator bore. See Figure 76-624.

9. Remove two hook type oil rings from the pump cover. See Figure 76-625.

10. Remove the pump to forward clutch housing selective washer.

11. Mark drive and driven gears for reassembly and remove drive gear. See Figure 76-626.

12. Remove driven gear from pump body. See Figure 76-627.

### b. Inspection

1. Inspect the gear pocket and crescent for scoring, galling or other damage.

- |                            |                                      |                             |
|----------------------------|--------------------------------------|-----------------------------|
| 1. MANUAL VALVE            | 13. RETAINING PIN                    | 21. 2-3 SHIFT VALVE         |
| 2. RETAINING PIN           | 14. GROOVED RETAINING PIN            | 22. 3-2 INTERMEDIATE SPRING |
| 3. BORE PLUG               | 15. BORE PLUG                        | 23. 2-3 MODULATOR VALVE     |
| 4. DETENT VALVE            | 16. 1-2 ACCUMULATOR SECONDARY SPRING | 24. 2-3 VALVE SPRING        |
| 5. DETENT REGULATOR VALVE  | 17. 1-2 ACCUMULATOR VALVE            | 25. 2-3 MODULATOR BUSHING   |
| 6. SPACER PIN              | 18. 1-2 ACCUMULATOR BUSHING          | 26. RETAINING PIN           |
| 7. DETENT REGULATOR SPRING | 19. 1-2 PRIMARY ACCUMULATOR VALVE    | 27. 3-2 VALVE               |
| 8. 1-2 SHIFT VALVE         | 20. 1-2 ACCUMULATOR PRIMARY SPRING   | 28. SPACER PIN              |
| 9. 1-2 DETENT VALVE        |                                      | 29. 3-2 VALVE SPRING        |
| 10. 1-2 REGULATOR SPRING   |                                      | 30. BORE PLUG               |
| 11. 1-2 REGULATOR VALVE    |                                      | 31. RETAINING PIN           |
| 12. 1-2 MODULATOR BUSHING  |                                      |                             |



74-873

Figure 76-614

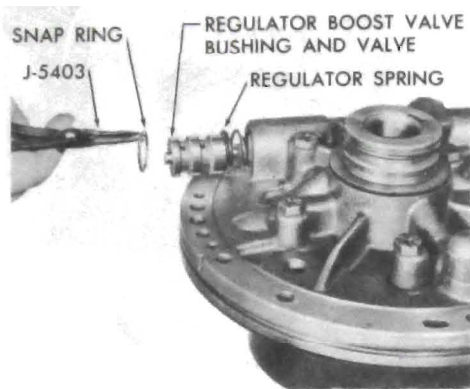

Figure 76-615

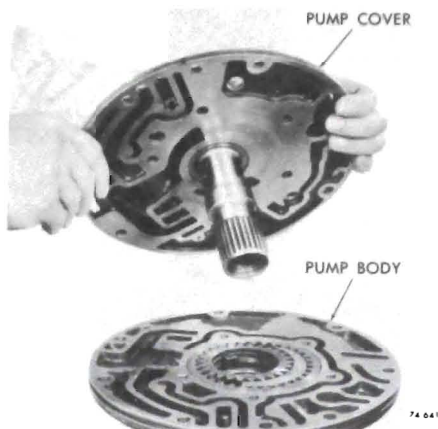

Figure 76-623

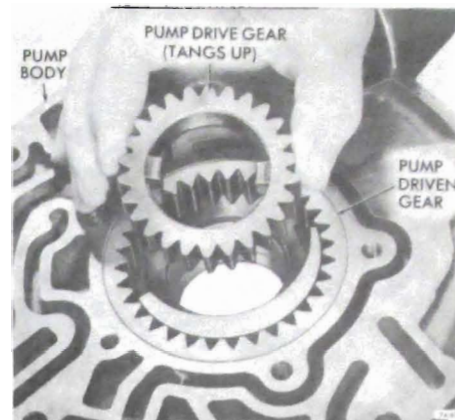

Figure 76-626

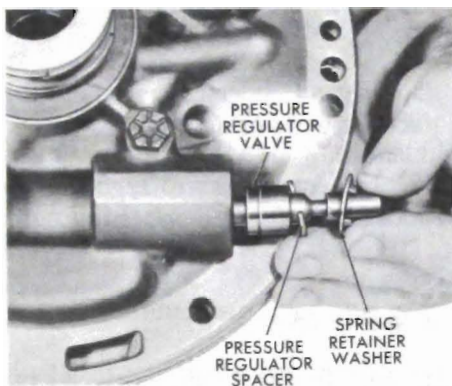

Figure 76-616

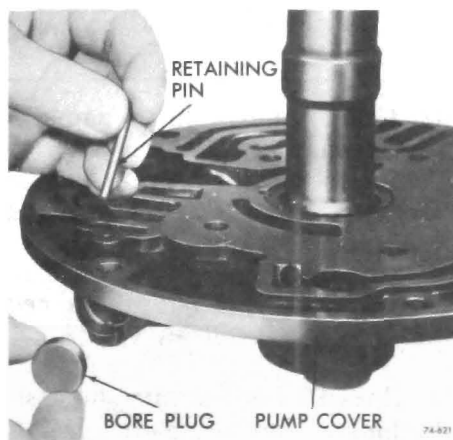

Figure 76-624

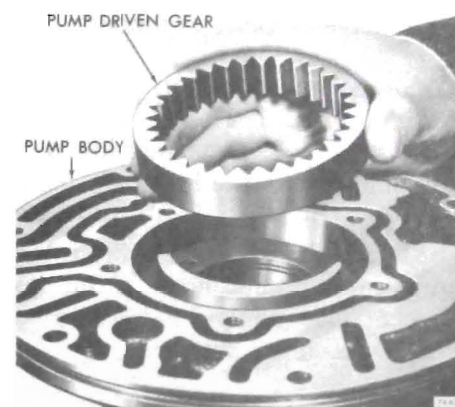

Figure 76-627

2. Place pump gears in pump and check the following clearance.

a. Pump body face to gear face clearance. Clearance should be .0005" - .0035". See Figure 76-628.

3. Check face of pump body for scores or nicks.

4. Check oil passages. See Figure 76-802.

5. Check for damaged cover bolt attaching threads.

6. Check for overall flatness of pump body face.

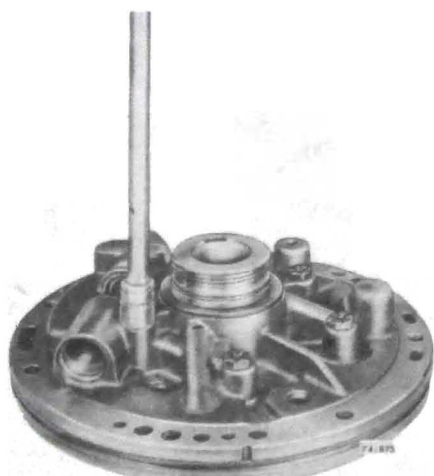

Figure 76-617

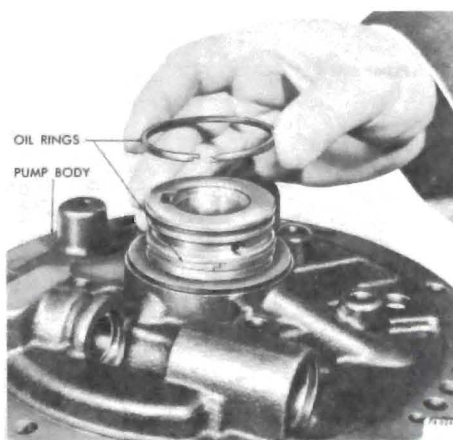

Figure 76-625



Figure 76-628

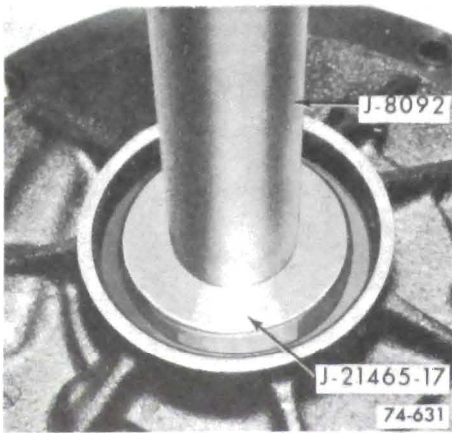

Figure 76-632

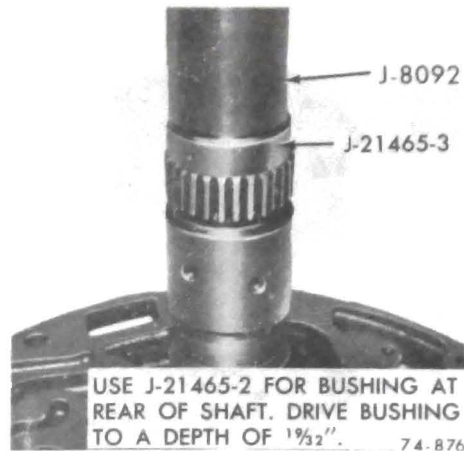

Figure 76-634

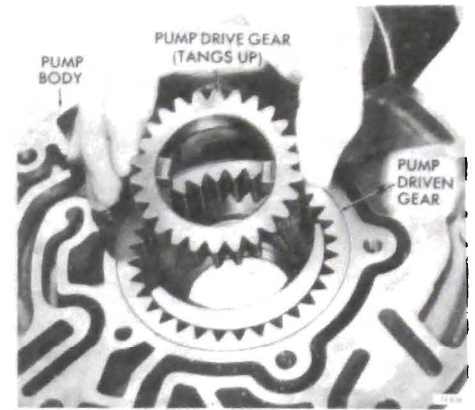

Figure 76-636

7. Check bushing for scores or nicks. If damaged replace as follows:

a. Support oil pump on wood blocks. Using Tool J-21465-17 and Drive Handle J-8092 press bushing out of oil pump body. See Figure 76-632.

b. Using Tool J-21465-17 drive bushing into pump body from gear pocket face until it is flush to .010 below machined surface.

8. Inspect the pump attaching bolt seals for damage, replace if necessary.

9. Inspect pump cover face for overall flatness.

10. Check for scores or chips in pressure regulator bore.

11. Check that all passages are open

and not interconnected. See Figure 76-801.

12. Check for scoring or damage at pump gear face.

13. Inspect stator shaft for damaged splines or scored bushings.

If replacement of bushing is necessary proceed as follows:

a. Thread J-21465-15 into stator shaft bushing. Thread Slide Hammer J-2619 into remover. Clamp slide hammer handle into vise. Grasp stator shaft and remove bushing. See Figure 76-633.

b. Using Installer J-21465-3 install bushing in front of shaft. See Figure 76-634.

c. See Figure 76-634 for installation of bushing in rear of shaft.

14. Inspect oil ring grooves for damage or wear.

15. Inspect selective washer thrust face for wear or damage.

16. Inspect pressure regulator and boost valve for free operation.

#### c. Reassembly

1. Install drive and driven pump gears into the pump body with alignment marks up. See Figures 76-635 and 76-636.

**CAUTION:** Install the drive gear with drive tangs up.

2. Install pressure regulator spring retainer, spacer(s) if used, and spring into the pressure regulator bore. See Figure 76-637.

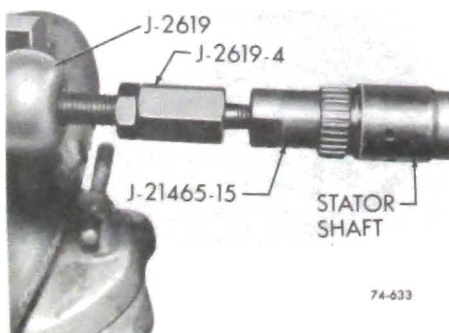

Figure 76-633

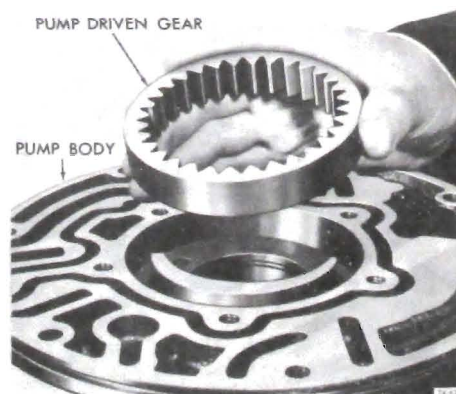

Figure 76-635

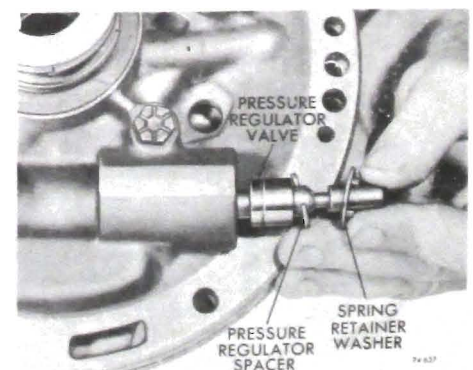

Figure 76-637

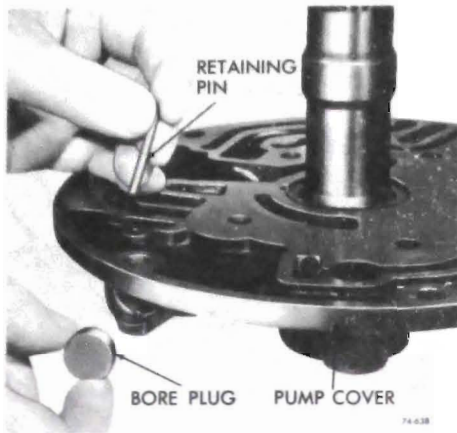

Figure 76-638

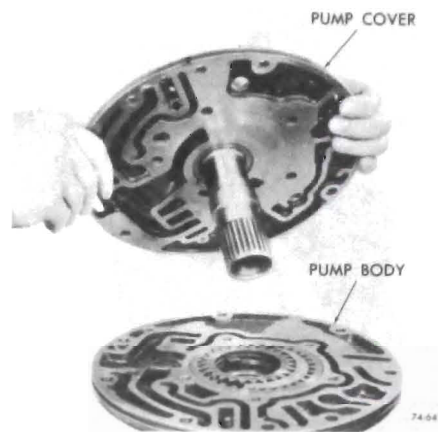

Figure 76-640



Figure 76-644

3. Install the pressure regulator valve from opposite end of bore, stem end first.

4. Install the boost valve into the bushing, stem end out, and install both parts into the pump cover by compressing the bushing against the spring.

5. Install the retaining snap ring.

6. Install the pressure regulator valve bore plug and retaining pin into opposite end of bore. See Figure 76-638.

7. Install the previously selected front unit selective thrust washer over the pump cover delivery sleeve.

8. Install two (2) hook type oil seal rings. See Figure 76-639.

9. Assembly pump cover to pump body. See Figure 76-640.



Figure 76-639

10. Install bolts as shown in Figure 76-641.

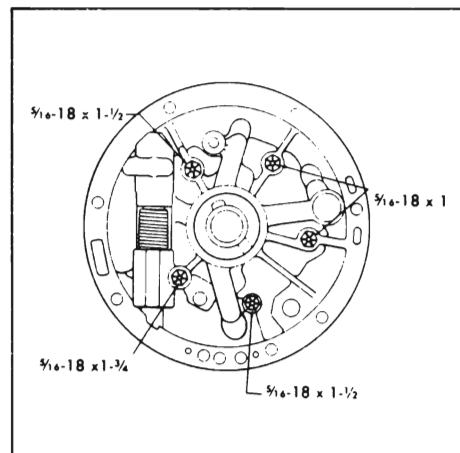

Figure 76-641

**NOTE: Leave bolts one turn loose at this time.**

11. Place Pump Aligning Strap, J-21368, over pump body and cover, and tighten tool. See Figure 76-642.

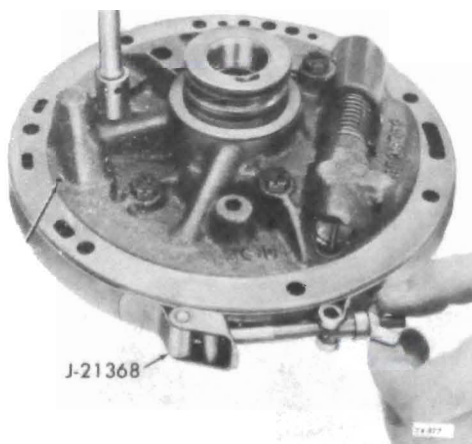

Figure 76-642

12. Tighten pump cover bolts. Torque to 15-20 lb.ft.

13. Install pump to case "O" ring seal.

## 76-21 FORWARD CLUTCH ASSEMBLY

### a. Disassembly

1. Place forward clutch and turbine shaft in hole in bench and remove the forward clutch housing to direct clutch hub snap ring. See Figure 76-644.

2. Remove the direct clutch hub. See Figure 76-645.

3. Remove the forward clutch hub and thrust washers. See Figure 76-646.

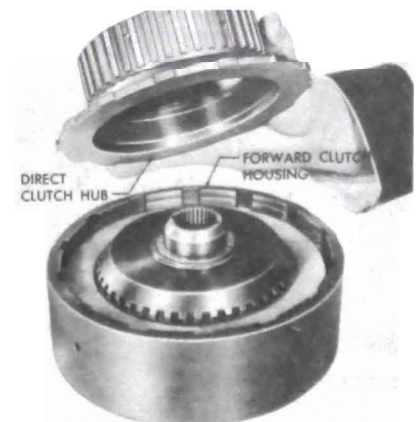

Figure 76-645



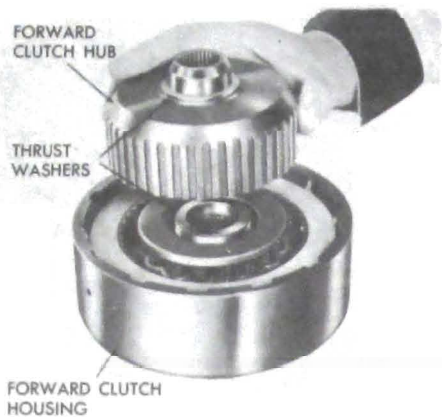

Figure 76-646

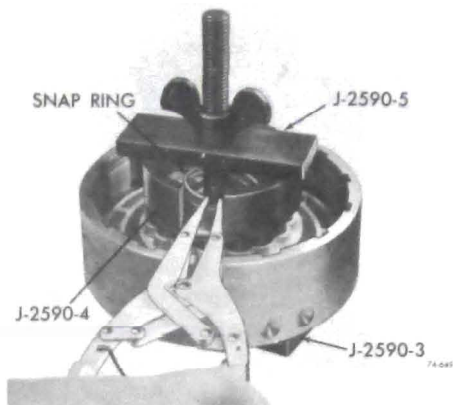

Figure 76-650

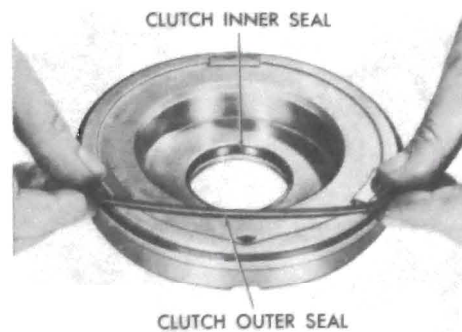

Figure 76-653

4. Remove five (5) radial groove composition and five (5) steel clutch plates. See Figure 76-647.

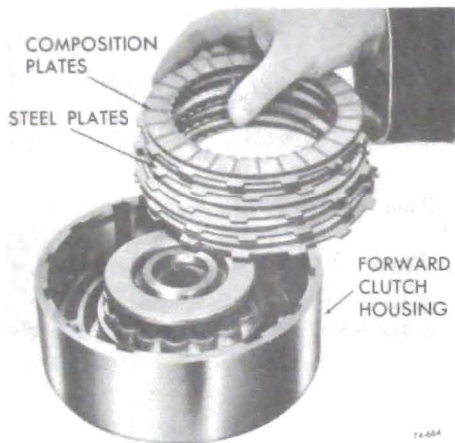

Figure 76-647

6. Using J-2590 clutch spring compressor, compress the spring retainer and remove the snap ring. See Figure 76-650.

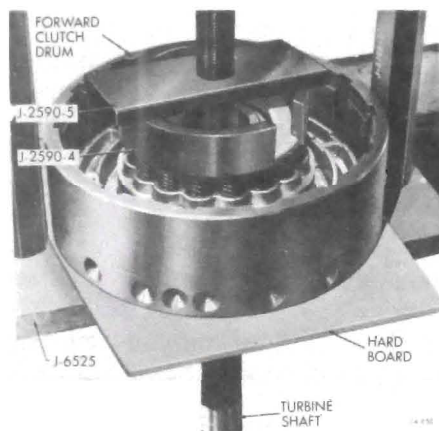

Figure 76-651

7. Remove tools, snap ring, spring retainer and sixteen clutch release springs. See Figure 76-652.

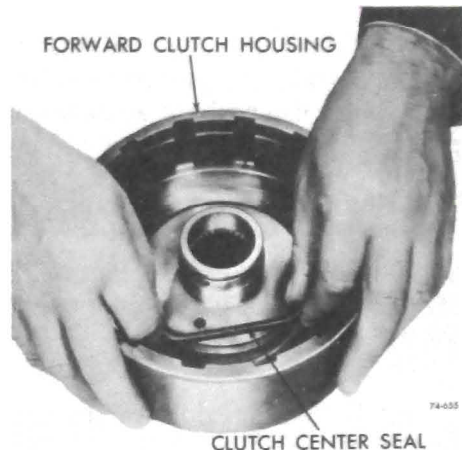

Figure 76-654

5. If necessary remove turbine shaft. See Figure 76-648.

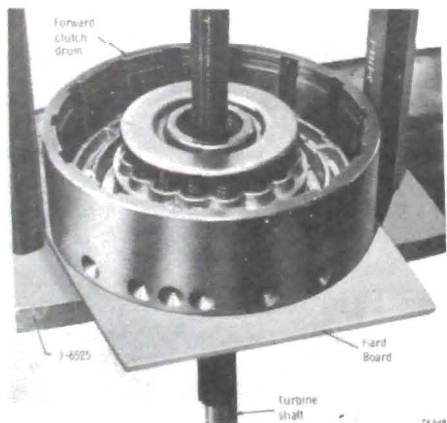

Figure 76-648

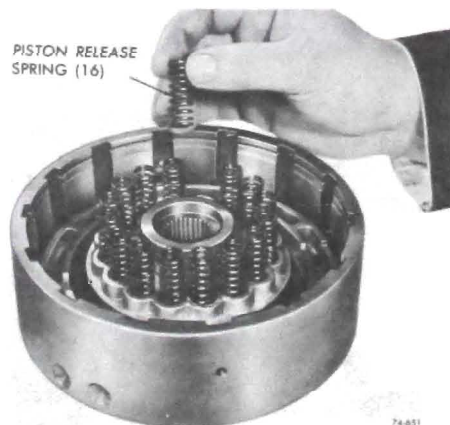

Figure 76-652

8. Remove clutch piston.

9. Remove inner and outer clutch piston seals. See Figure 76-653.

10. Remove center piston seal from the forward clutch housing. See Figure 76-654.

**b. Inspection**

1. Inspect drive and driven clutch plates for signs of burning, scoring, or wear. See Figure 76-655.

2. Inspect sixteen springs for collapsed coils or signs of distortion.

3. Inspect clutch hubs for worn

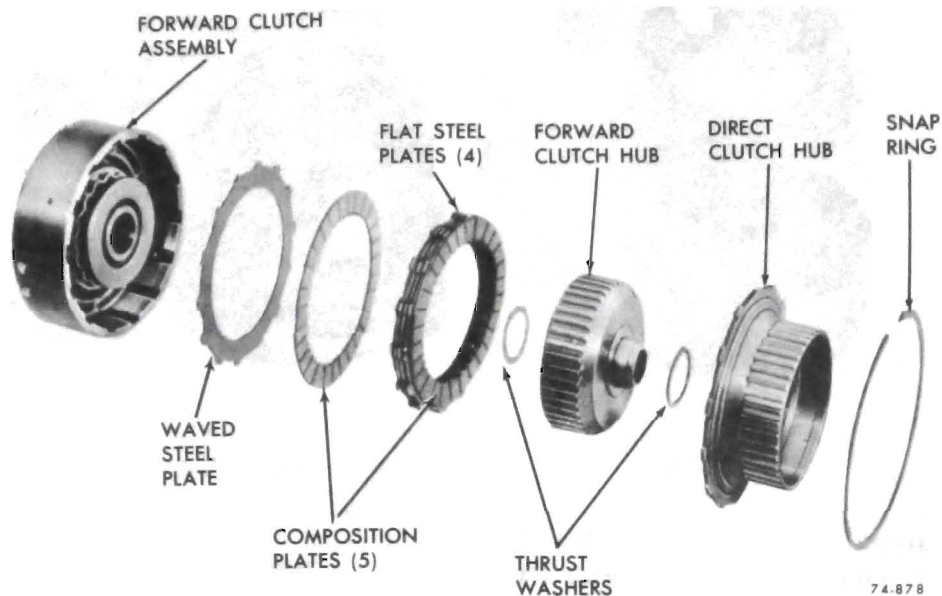

Figure 76-655

splines, proper lubrication holes and worn thrust faces.

4. Inspect the piston for cracks.
5. Inspect clutch housing for wear, scoring, open oil passages and free operation of the ball check.
6. Inspect turbine shaft.
  - a. Inspect for open lubrication passages at each end.
  - b. Inspect splines for damage.
  - c. Inspect ground bushing journals for damage.
  - d. Inspect shaft for cracks or distortion.

**NOTE: Turbine shaft and clutch housing are serviced separately.**

**c. Reassembly**

1. Place new inner, and outer oil seals on clutch piston, lips face away from spring pockets. See Figure 76-653.

**NOTE: The forward and direct clutch pistons have identical inside and outside diameters. It is possible to**

**reverse the pistons during reassembly, therefore care should be exercised to make certain the proper piston be installed in the clutch assemblies as shown in Figure 76-656. The forward clutch piston can be identified by the blind hole in the clutch apply face of the piston.**

2. Place a new center seal on the clutch housing, lip faces up. See Figure 76-654.
3. Place Seal Protector Tool J-21362, over clutch hub and install outer clutch piston Seal Protector J-21409, into clutch drum and install piston. See Figure 76-660.
4. Install clutch release springs into pockets in piston. See Figure 76-661.

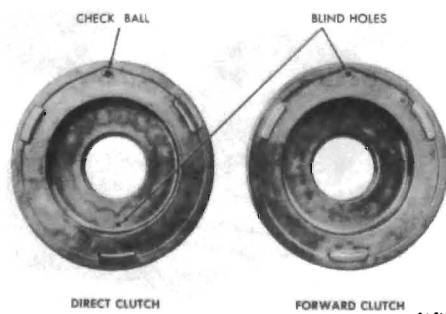

Figure 76-656

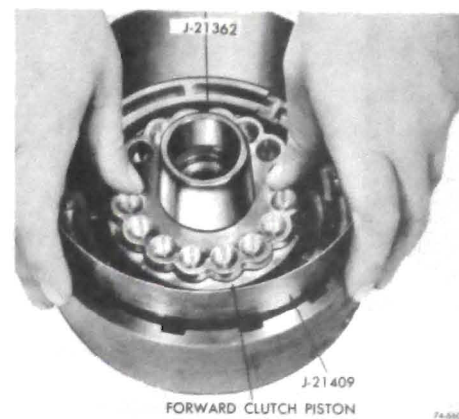

Figure 76-660



Figure 76-661

5. Place spring retainer and snap ring on springs.
6. Compress springs using Clutch Compressor Tool J-2590, and install snap ring. See Figure 76-662.

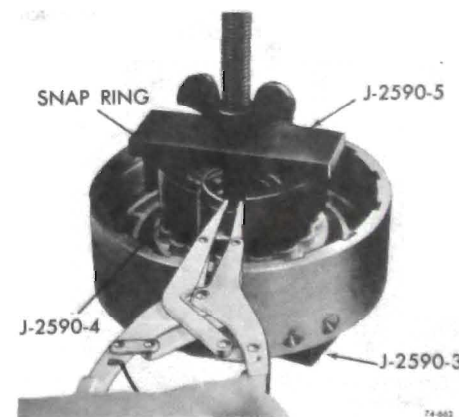

Figure 76-662

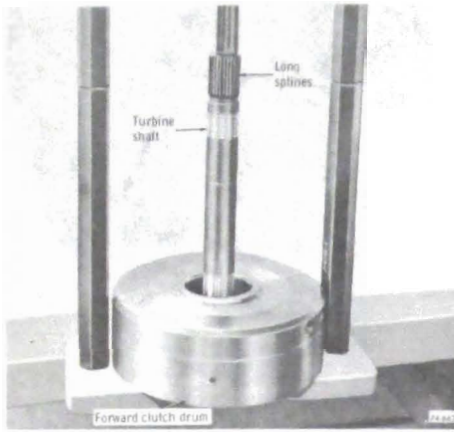

Figure 76-663

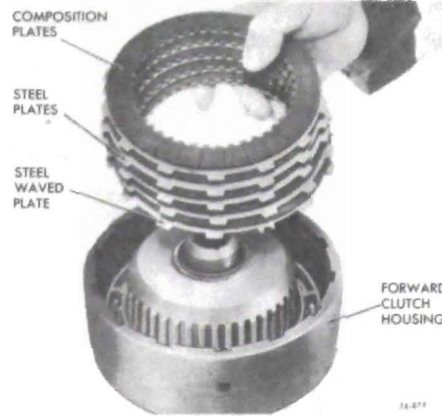

Figure 76-665

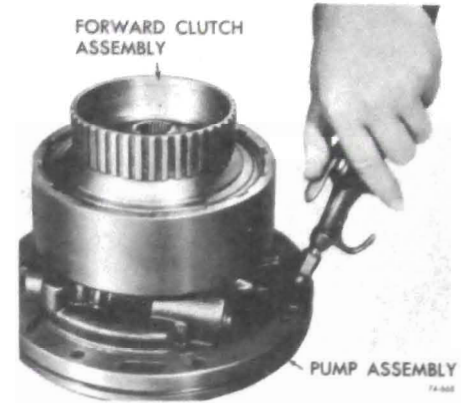

Figure 76-668

**NOTE:** If turbine shaft was not removed, install retainer as shown in Figure 76-648.

7. If removed, install turbine shaft into forward clutch drum. See Figure 76-663.

8. Install the forward clutch hub thrust washers on forward clutch hub. Retain with petroleum jelly. See Figure 76#664.

9. Place forward clutch hub into forward clutch housing. See Figure 76-664.

10. Oil and install five (5) radial groove composition, four (4) flat steel clutch plates and one (1) waved steel plate (plate with notches), starting with waved steel and alternating composition and steel plates. See Figure 76-665.

**CAUTION:** Do not confuse the flat steel clutch plate (plate with "V" notch) with the waved steel clutch plate (plate with "U" notch.) **NOTE:** Radially grooved composition clutch plates are installed at the factory only. All service composition plates have the smooth surface configuration.

11. Install the direct clutch hub and retaining snap ring. See Figure 76-667.

12. Place forward clutch housing on pump delivery sleeve and air check clutch operation.

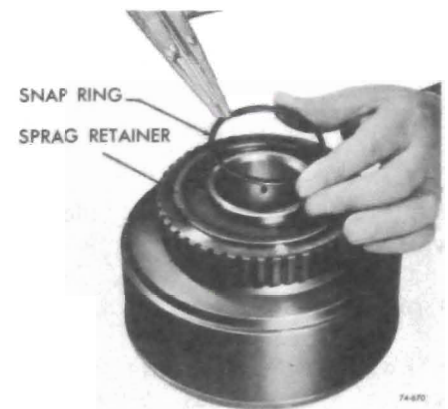

Figure 76-670

### 76-22 DIRECT CLUTCH AND INTERMEDIATE SPRAG

#### a. Disassembly

1. Remove sprag retainer snap ring and retainer. See Figure 76-670.

2. Remove sprag outer race, bushings and sprag assembly. See Figure 76-671.

3. Turn unit over and remove backing plate to clutch housing snap ring. See Figure 76-672

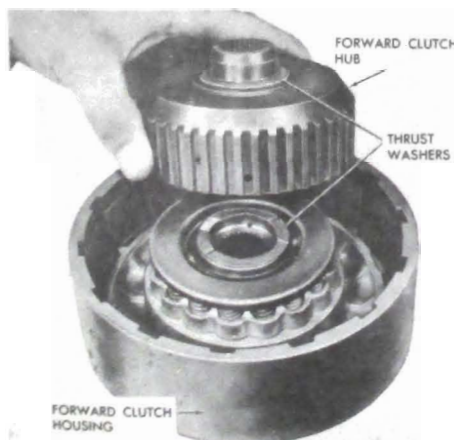

Figure 76-664



Figure 76-667



Figure 76-671

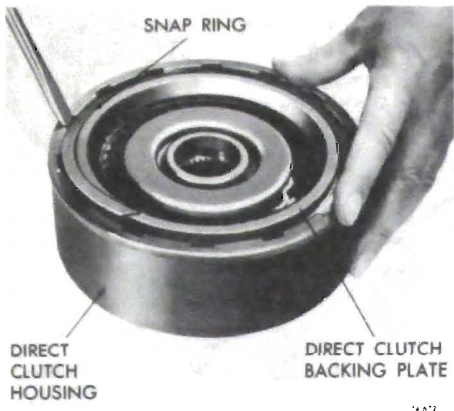

Figure 76-672

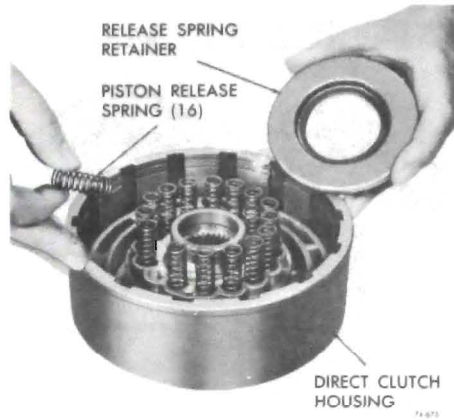

Figure 76-675



Figure 76-677

4. Remove direct clutch backing plate, (five) 5 composition faced and (five) 5 steel clutch plates. See Figure 76-673.

5. Using Tool J-2590, compress spring retainer and remove snap ring. See Figure 76-674.

2. Inspect sprag bushings for wear or distortion.

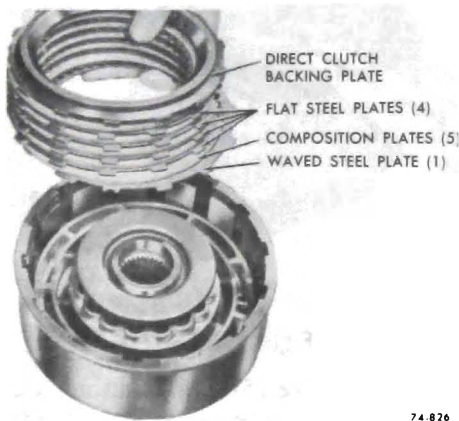

Figure 76-673

6. Remove retainer and sixteen (16) piston release springs. See Figure 76-675.

7. Remove direct clutch piston. See Figure 76-676.

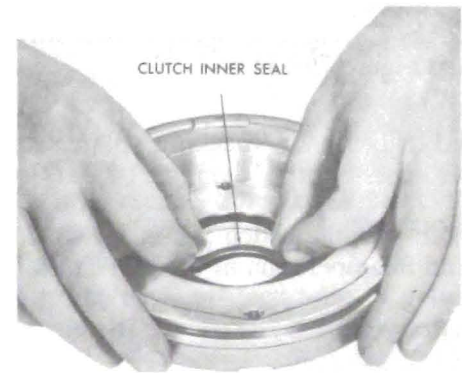

Figure 76-678

**NOTE:** Model "BB" uses five (5) flat steel plates, no waved steel plate as used in other models.



Figure 76-676

3. Inspect the inner and outer races for scratches or wear.

4. Inspect clutch housing for cracks.

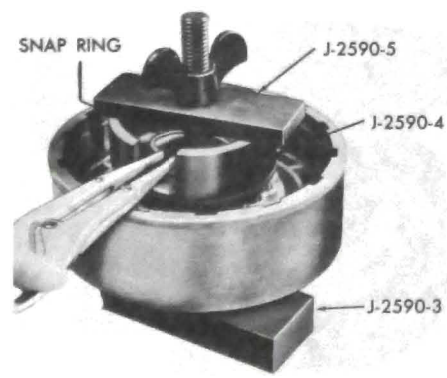

Figure 76-674

8. Remove outer seal from piston. See Figure 76-677.

9. Remove inner seal from piston. See Figure 76-678.

10. Remove center piston seal from direct clutch housing. See Figure 76-682.

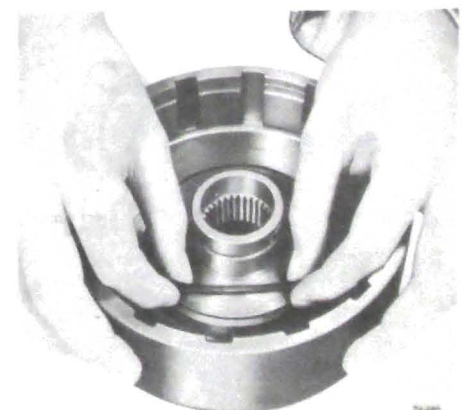

Figure 76-682

**b. Inspection**

1. Inspect sprag assembly for popped or loose sprags. See Figure 76-683.

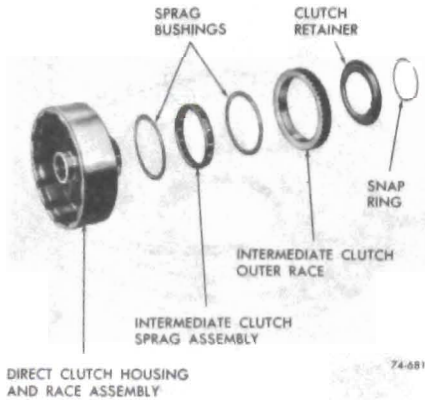

Figure 76-683

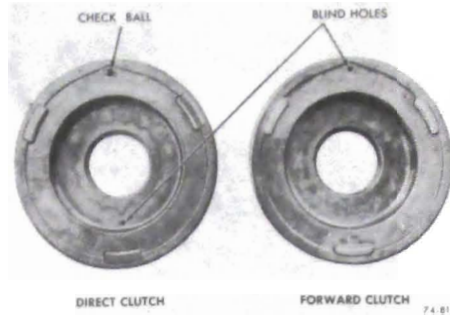

Figure 76-685



Figure 76-687

wear, proper opening of oil passages or wear on clutch plate drive lugs.

5. Inspect the drive and driven clutch plates for signs of wear or burning. See Figure 76-684.

6. Inspect the backing plate for scratches or other damage.

7. Inspect the clutch piston for cracks and free operation of the ball check.

**c. Reassembly**

1. Install a new inner clutch piston seal on piston with lip facing away from spring pockets. Make certain correct piston is used. See Figure 76-678.

2. Install a new outer clutch piston seal with lip away from spring pockets. See Figure 76-677

**NOTE: Make certain the piston has a ball check. The piston with a blind hole is for the forward clutch assembly. See Figure 76-685.**

3. Install a new center seal on clutch housing with lip of seal facing up. See Figure 76-682.

4. Place Seal Protectors, Tools J-21362 - Inner, J-21409 - Outer, over hub and clutch housing and install clutch piston. See Figure 76-686.

5. Install sixteen (16) springs into the piston. See Figure 76-687.

6. Place spring retainer and snap ring on springs.

7. Using Tool J-2590, install snap ring. See Figure 76-688.

8. Lubricate with transmission fluid

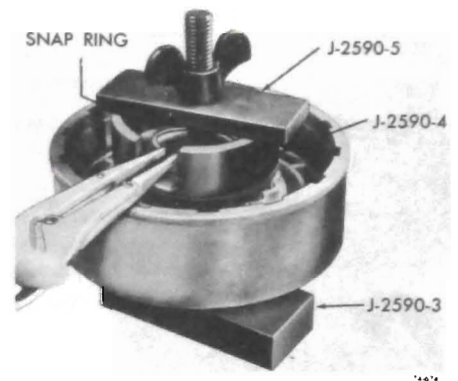

Figure 76-688

and install five (5) composition, four (4) flat steel, and one (1) waved steel plate (plate with "U" notch, starting with the waved steel and alternating composition and steel. See Figure 76-689.

**NOTE: Model "BB" does not use a**

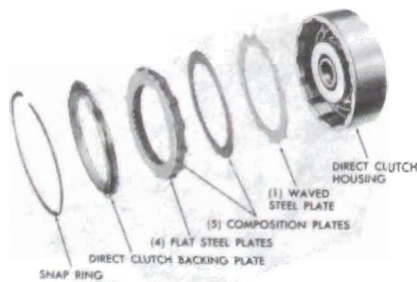

Figure 76-684

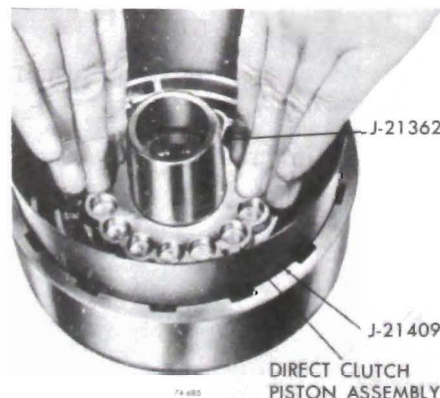

Figure 76-686

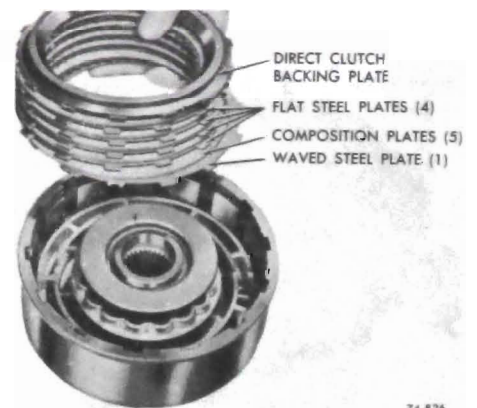

Figure 76-689

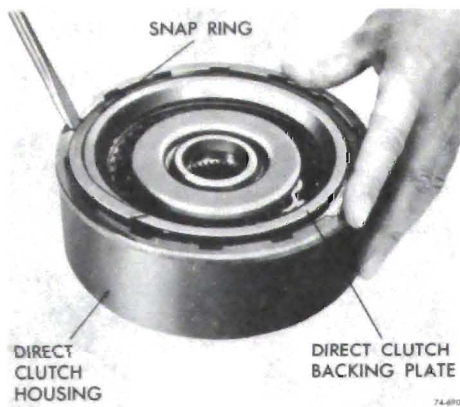

Figure 76-690

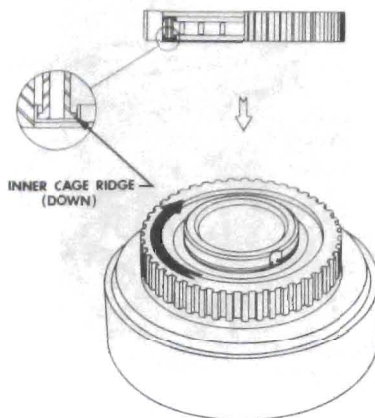

Figure 76-692

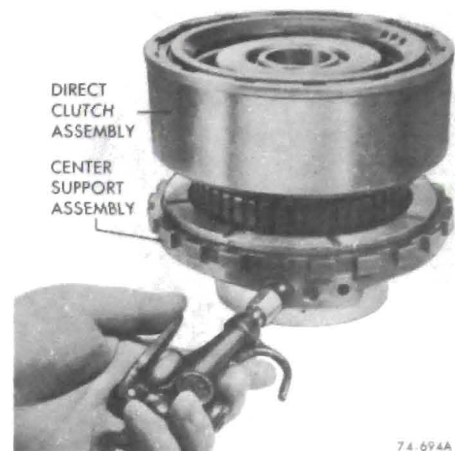

Figure 76-695

waved steel plate. Five (5) flat steel plates are used.

**CAUTION:** Do not confuse the flat steel clutch plate (plate with "V" notch) with the waved steel clutch plate (plate with "U" notch).

**NOTE:** Do not use radial groove composition plates here.

9. Install the clutch backing plate.

10. Install the backing plate retaining snap ring. See Figure 76-690.

11. Turn unit over and install one sprag bushing, cup side up, over inner race.

12. Install sprag assembly into outer race.

13. With ridge on inner cage facing down start sprag and outer race over inner race with clockwise turning motion. See Figure 76-691.

**NOTE:** Outer race should not turn counterclockwise after installation. See Figure 76-692.



Figure 76-693

14. Install sprag bushing over sprag, cup side down.

15. Install sprag retainer over sprag, cup side down. See Figure 76-693.

16. Install sprag retainer snap ring. See Figure 76-694.

17. Place direct clutch assembly over center support and air check operation of direct clutch. See Figure 76-695.

**NOTE:** If air is applied through the reverse passage, (right oil feed hole) it will escape from the direct clutch passage (left oil feed hole). This is considered normal. Apply air through left oil feed hole to actuate piston and move direct clutch.

### 76-23 CENTER SUPPORT AND INTERMEDIATE CLUTCH

#### a. Disassembly

1. Remove four (4) hook type oil seal rings from center support. See Figure 76-705.

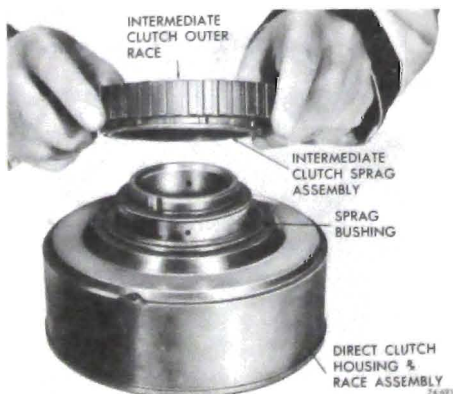

Figure 76-691

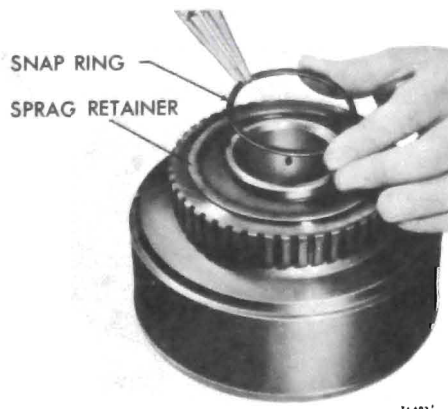

Figure 76-694

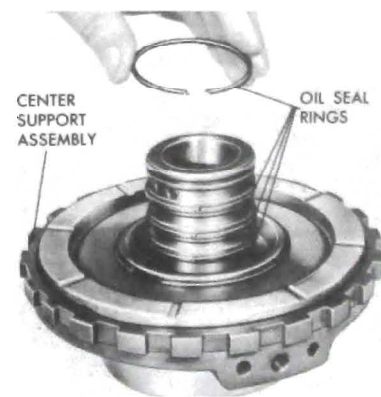

Figure 76-705

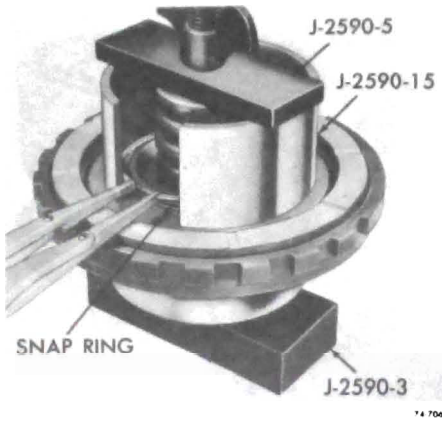

Figure 76-706

2. Using Clutch Compressor J-2590, compress spring retainer and remove snap ring. See Figure 76-706.

3. Remove spring retainer. See Figure 76-707. Remove three (3) clutch release springs. See Figure 76-708.

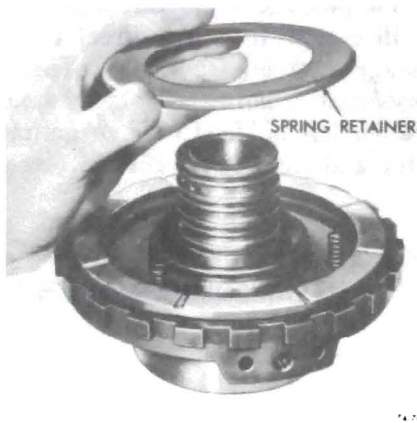

Figure 76-707

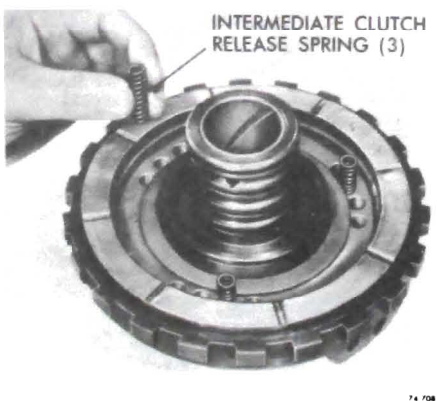

Figure 76-708

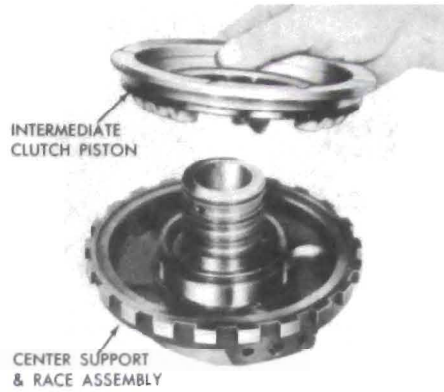

Figure 76-710

4. Remove the intermediate clutch piston. See Figure 76-710.

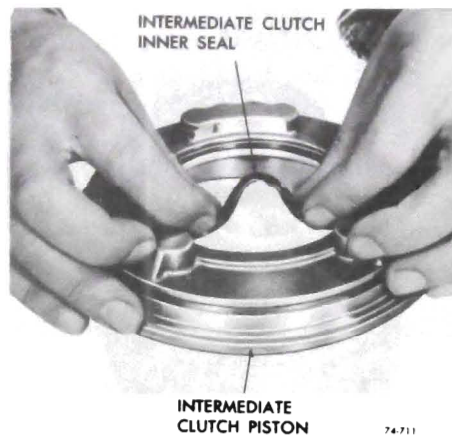

Figure 76-711

**NOTE:** Do not remove the three (3) bolts retaining the roller clutch inner race to the center support.

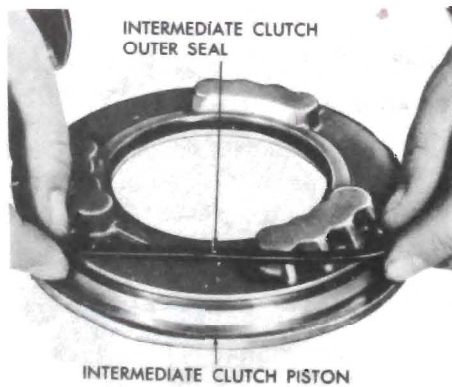

Figure 76-712

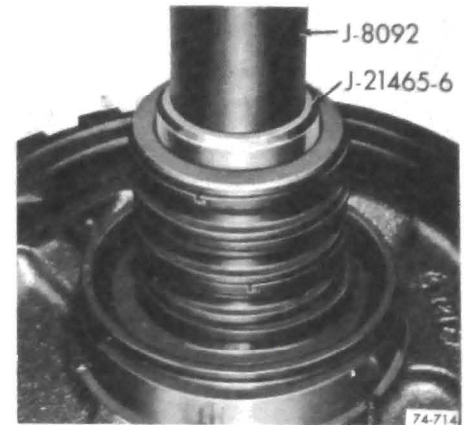

Figure 76-713

5. Remove the inner piston seal. See Figure 76-711.

6. Remove the outer piston seal. See Figure 76-712.

**b. Inspection**

1. Inspect the roller clutch inner race for scratches or indentations. Be sure the lubrication hole is open.

2. Inspect the bushing for scoring, wear or galling. If replacement is necessary proceed as follows:

a. Using Tool J-21465-6, remove bushing. See Figure 76-713.

b. From front side of center support, align elongated slot in bushing with drilled hole in the oil delivery sleeve closest to the piston. Using Tool J-21465-6 and Drive Handle J-8092.

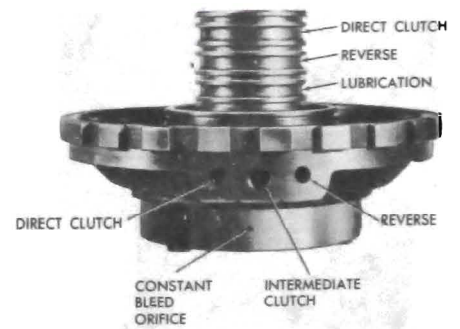

Figure 76-714

drive bushing squarely into the bore until the bushing is flush to .010" below top of oil delivery sleeve. 2. Check the oil ring grooves for damage.

3. Air check the oil passages to be sure they are open and not interconnected. See Figure 76-714. Be sure constant bleed plug orifice is open.

4. Inspect piston sealing surfaces for scratches.

5. Inspect the piston seal grooves for nicks or other damage.

6. Inspect the piston for cracks or porosity.

7. Inspect the release springs for distortion.

#### c. Reassembly

1. Install new inner seal on the piston with lip of the seal facing away from the spring pocket. See Figure 76-711.

2. Install new outer seal with the lip away from the spring pockets. See Figure 76-712.

3. Install inner seal protector, Tool J-21363, on the center support hub, install piston. See Figure 76-720.

4. Install three (3) release springs into the piston, space equally during assembly. See Figure 76-721.



Figure 76-720

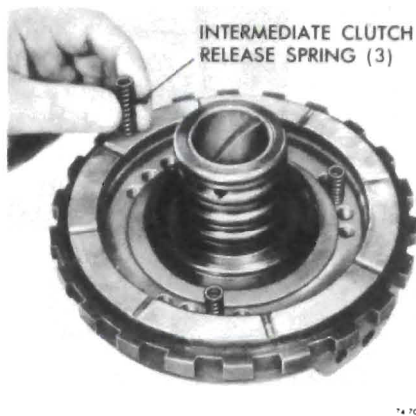

Figure 76-721

5. Place the spring retainer and snap ring over the springs.

6. Using the Clutch Spring Compressor, J-2590, compress the springs and install the snap ring. See Figure 76-722.

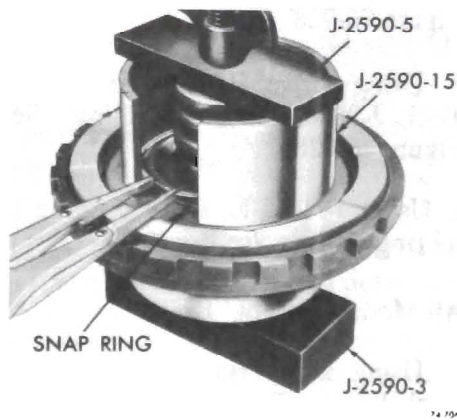

Figure 76-722

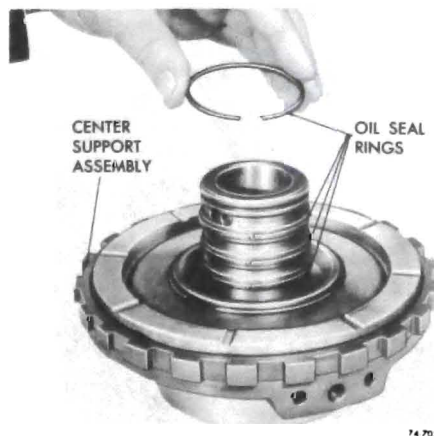

Figure 76-723

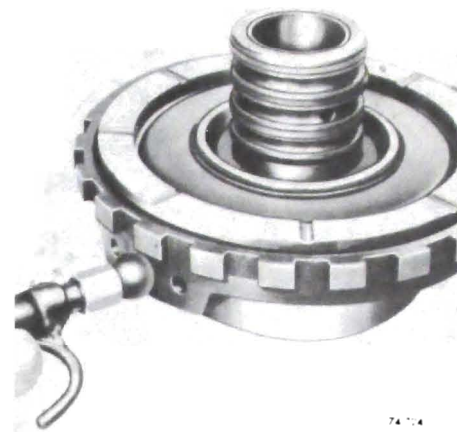

Figure 76-724

7. Install four (4) hook type oil rings. See Figure 76-723.

8. Air check operation of intermediate clutch piston. See Figure 76-724.

9. Install center support into roller clutch in reaction carrier. See Figure 76-598.

## 76-24 INSPECTION OF TRANSMISSION PARTS

### a. Case Bushing

1. Inspect case bushing for wear or galling. If replacement is necessary proceed as follows:

a. Thread Extension Handle J-21465-13 into Bushing Remover J-21465-8. Using Drive Handle J-8092 remove bushing. See Figure 76-725.

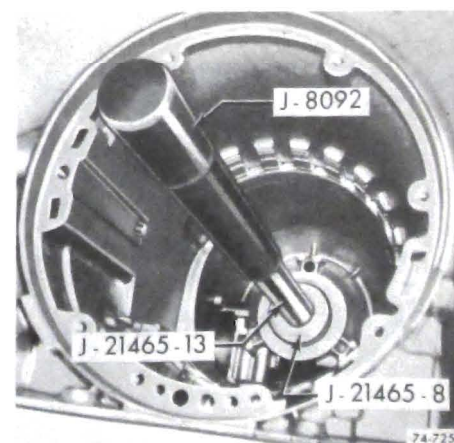

Figure 76-725



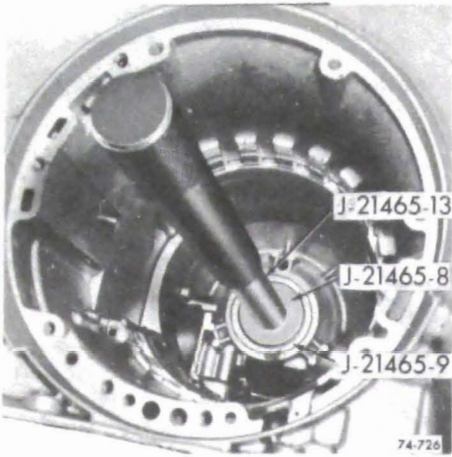

Figure 76-726

b. Using Adapter J-21465-9 on J-21465-8 install new bushing into case, until .040" - .055" above selective thrust washer face. See Figure 76-726.

c. Using J-21465-10 stake bushing in oil groove.

**b. Inspection of Front and Rear Bands**

1. Inspect the lining for cracks, flaking, burning or looseness. See Figure 76-727.

2. Inspect the bands for cracks or distortion.

3. Inspect the end for damage at the anchor lugs or apply lugs.

**c. Inspection of Case Extension**

1. Inspect the bushing for excessive

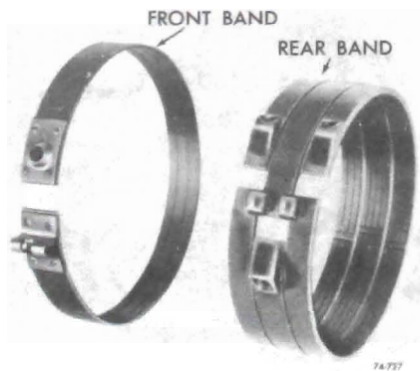

Figure 76-727

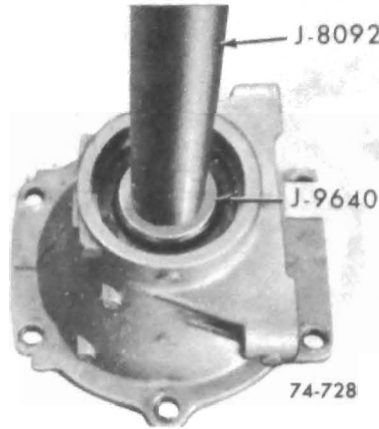

Figure 76-728

wear or damage. If replacement is necessary, remove rear seal. position housing on bench with seal end up, and proceed as follows:

**Model "BT"**

a. Using Drive Handle J-8092 and Tool J-9640, remove bushing. See Figure 76-728.

b. Using Drive Handle J-8092 and Tool J-9640, install bushing. See Figure 76-728.

c. Using J-21465-10, stake bushing in oil ring groove. See Figure 76-731.

**All Models Except "BT"**

d. Using Drive Handle J-8092 and Tool J-21465-17, remove bushing. e. Using Drive Handle J-8092 and Tool J-21465-17, install bushing. f. Using

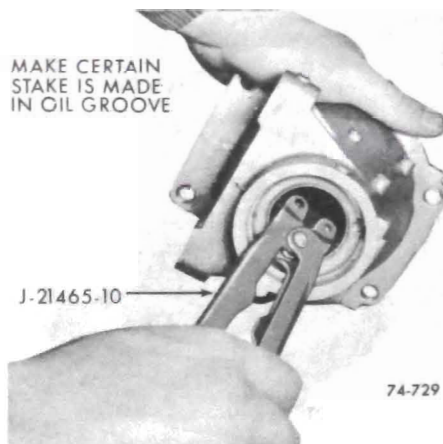

Figure 76-731

J-21465-10, stake bushing in oil grooves. See Figure 76-731.

2. Inspect the housing for cracks or porosity.

3. Be sure rear seal drain back port is not obstructed.

**d. Inspection of Manual and Parking Linkage**

1. Inspect the parking pawl actuator rod for cracks, broken spring retainer lugs. See Figure 76-530.

2. Inspect the actuator spring for damage.

3. Inspect actuator for a free fit on the actuator rod.

4. Inspect the parking pawl for cracks or wear, if removed.

5. Inspect the manual shaft for damaged threads, rough oil seal surface or loose lever.

6. Inspect the inside detent lever for cracks or a loose pin.

7. Inspect the parking pawl shaft for damaged retainer groove if removed.

8. Inspect the parking pawl return spring for deformed coils or ends.

9. Inspect the parking lock bracket for cracks or wear.

10. Inspect detent roller and spring assembly.

**e. Inspection of Case Assembly**

1. Inspect case assembly for cracks, porosity or interconnected passages. See Figure 76-804.

**NOTE: If case porosity exists, repair following procedures outlined in Paragraph 76-87, subparagraph c.**

2. Check for good retention of ban anchor pins.

3. Inspect all threaded holes for thread damage.

4. Inspect the intermediate clutch

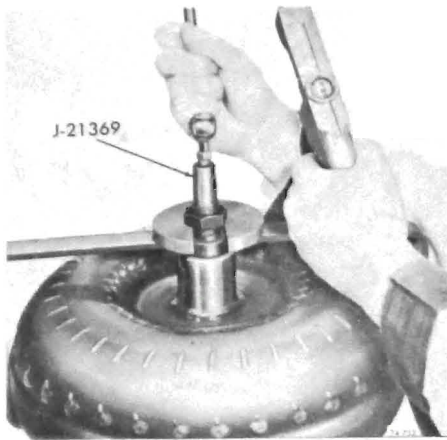

Figure 76-732

driven plate lugs for damage or brinelling.

5. Inspect the snap ring grooves for damage.
6. Inspect the bore of the governor assembly for scratches or scoring.
7. Inspect the modulator valve bore for scoring or damage.
8. Inspect the cup plug inside the case for good staking and sealing.

#### f. Inspection of Torque Converter

- l. Check converter for leaks as follows: (See Figure 76-732.)
  - a. Install Tool J-21369, and tighten.
  - b. Fill converter with air; 80 psi.
  - c. Submerge in water and check for leaks.

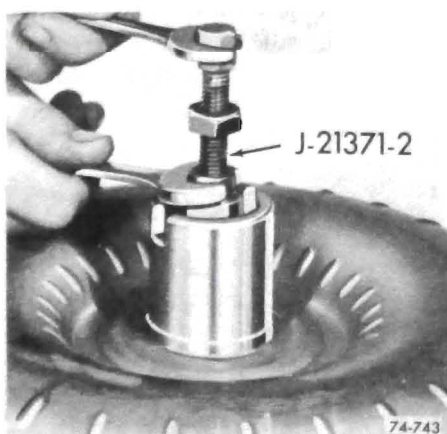

Figure 76-743

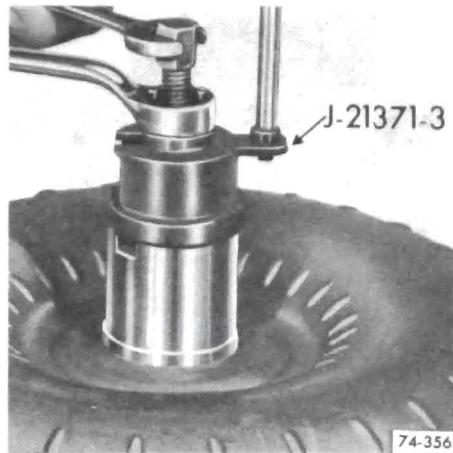

Figure 76-744

2. Check converter hub surfaces for signs of scoring or wear.

3. Check converter end clearance as follows:

- a. Install Tool J-21371-2 and tighten brass nut. See Figure 76-743.
- b. Install Tool J-21371-3 and tighten hex nut. See Figure 76-744.
- c. Install dial indicator set at 0 as shown in Figure 76-745.
- d. Loosen hex nut. When nut is fully loosened the reading obtained on the dial indicator will be converter end clearance. If clearance is .050" or over and the oil has the appearance of having been mixed with aluminum paint, replace the converter. See Figure 76-745.

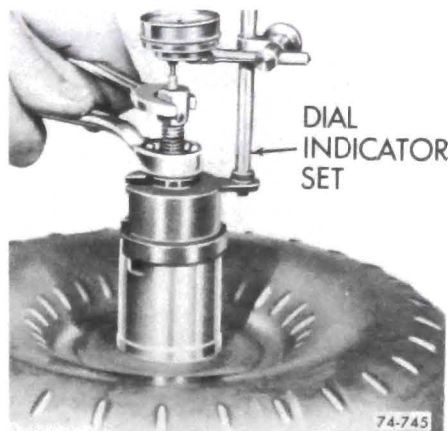

Figure 76-745

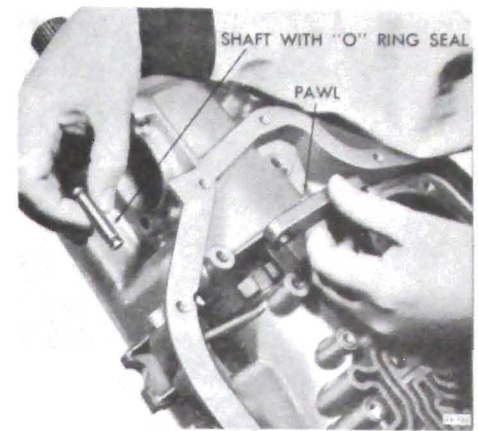

Figure 76-746

#### ASSEMBLY OF MAJOR UNIT

**NOTE:** The first three steps can be omitted if the parts involved were not removed on disassembly.

1. Install the parking pawl, tooth toward the inside case and parking pawl shaft. See Figure 76-746.
2. Install the parking pawl shaft retainer clip. See Figure 76-747.
3. Install cup plug and drive into case, using a 3/8" dia. rod, until parking pawl shaft bottoms on case rib. See Figure 76-748.
4. Install the parking pawl return spring, square end hooked on pawl. See Figure 76-749.
5. Install the parking lock bracket, guides over parking pawl, using two

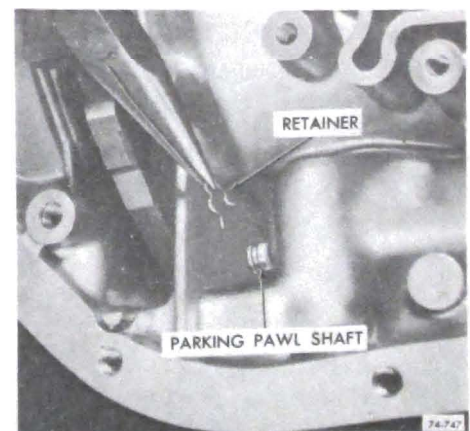

Figure 76-747

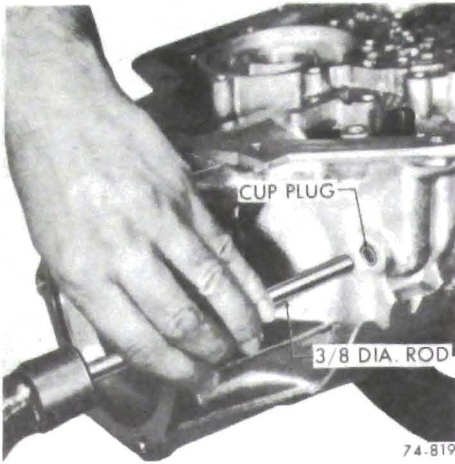

Figure 76-748

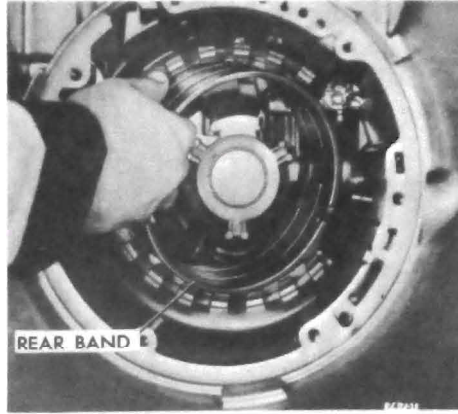

Figure 76-751

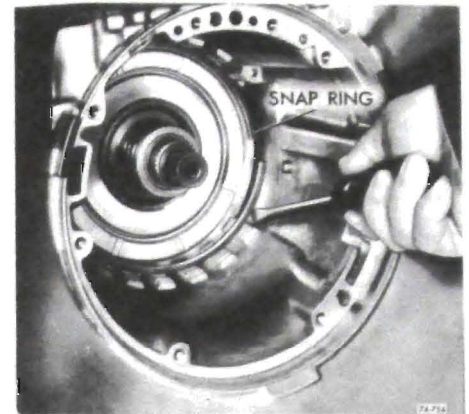

Figure 76-754

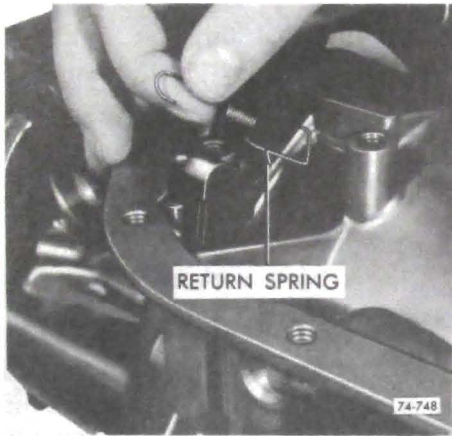

Figure 76-749

Check band to be sure band ends are seated on lugs.

7. Lubricate and install gear selective washer into slots provided inside rear of transmission case. See Figure 76-752.

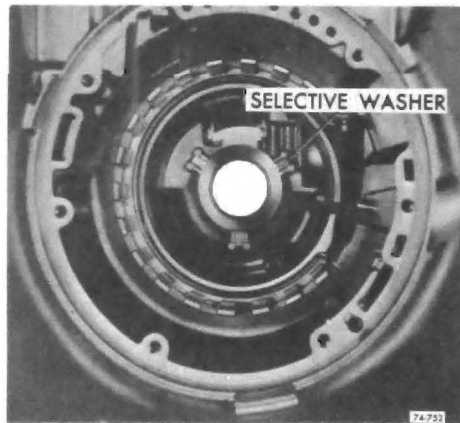

Figure 76-752

8. Install complete gear unit assembly into case making certain center support bolt hole is properly aligned with hole in case. See figure 76-753.

**NOTE: Make certain tangs on output shaft to case thrust washer are positioned in pockets. See Figure 76-589.**

9. Install center support to case retaining snap ring with bevel side up and locating gap adjacent to band anchor pin. Make certain ring is properly seated in case. See Figure 76-754.

10. Install case to center support bolt by placing the center support locating tool J-23093 into the case direct clutch passage, with the handle of the tool pointing to the right as viewed from the front of the transmission and parallel to the bell housing mounting face. See Figure 76-755.

attaching bolts torque to 15-20 lb.ft. See Figure 76-750.

6. Install the rear band assembly so that the two lugs index with the two anchor pins. See Figure 76-751

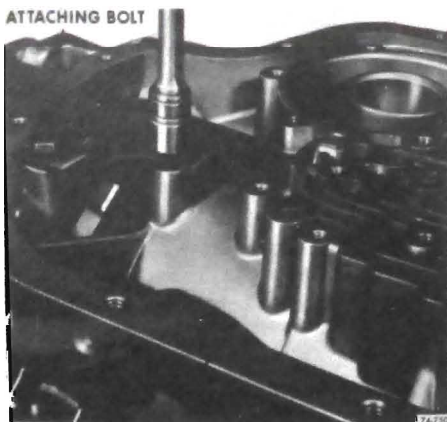

Figure 76-750

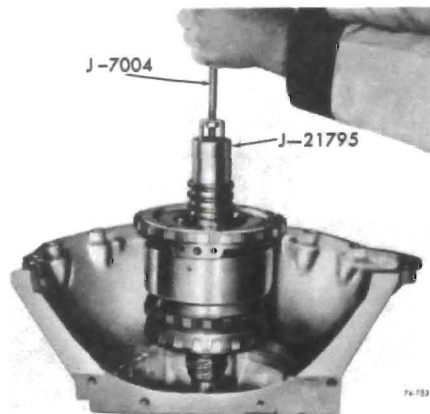

Figure 76-753



Figure 76-755

Apply pressure downward on Tool J-23093 handle which will tend to rotate the center support counter-

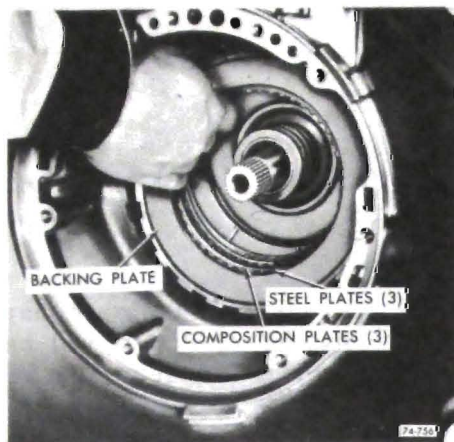

Figure 76-756

-clockwise as viewed from the front of the transmission. While holding the center support firmly counter-clockwise against the case splines, torque the case to center support bolt to 20-25 lb. ft., using a 3/8" 12-point thin wall deep socket.

**CAUTION:** When using locating tool, care must be taken not to raise burrs on the case valve body mounting face.

11. Lubricate with transmission fluid and install three (3) steel and three (3) composition intermediate clutch plates. Start with waved steel and composition and steel clutch plates. See Figure 76-756.

**NOTE:** No waved plate used in Model "BB".

12. Install the intermediate clutch backing plate ridge up.

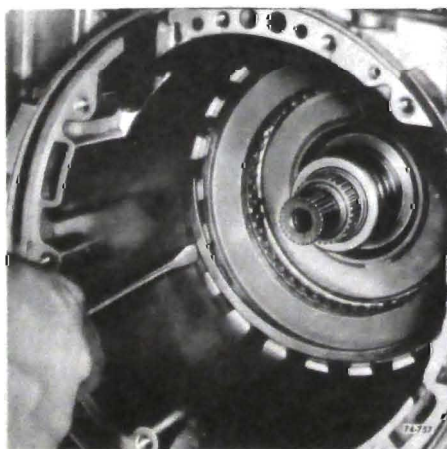

Figure 76-757

13. Install the backing plate to case snap ring. Gap in snap ring should be opposite band anchor pin. See Figure 76-757.

**NOTE:** Both sides of this snap ring are flat.

14. Check rear end play as follows: See Figure 76-758.

a. Install J-7004 into an extension housing attaching bolt hole. See Figure 76-758.

b. Mount the Dial Indicator, J-8001, on the rod and index with the end of the output shaft.

c. Apply air pressure to apply the intermediate clutch (center oil passage) while moving the output shaft in and out to read the end play. End play should be from .003" - .019". The selective washer controlling this end play is the steel washer having 3 lugs that is located between the thrust washer and the rear face of the transmission case.

If a different washer thickness is required to bring the end play within specification, it can be selected from the following chart.

Thickness	Notches and/or Numeral	
.074-.078	None	1
.082-.086	1 Tab Side	2
.090-.094	2 Tabs Side	3
.098-.102	1 Tab O.D.	4
.106-.110	2 Tabs O.D.	5
.114-.118	3 Tabs O.D.	6

15. Install front band with band anchor hole placed over the band anchor

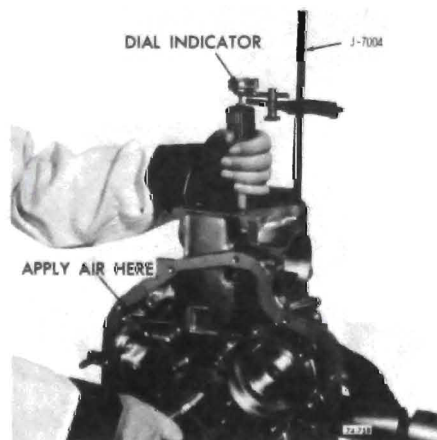

Figure 76-758

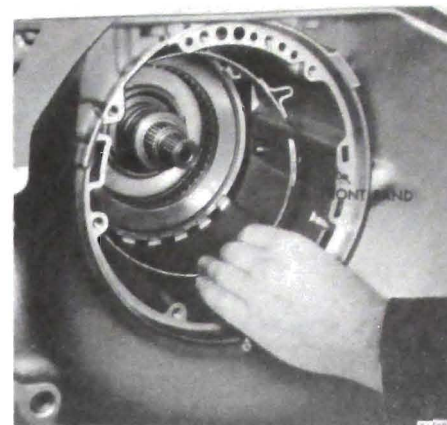

Figure 76-760

pin and apply lug facing servo hole. See Figure 76-760.

16. Install the direct clutch and intermediate sprag assembly. It will be necessary to twist the housing to allow the sprag outer race to index with the clutch drive plates. The housing hub will bottom on the sun gear shaft. See Figure 76-761.

**NOTE:** Removal of direct clutch, drive and driven plates, may be helpful.

17. Install the forward clutch hub to direct clutch housing thrust washer on the forward clutch hub. Retain with petroleum jelly.

18. Install the forward clutch and turbine shaft assembly, see Figure 76-762, indexing the direct clutch hub so end of the mainshaft will bottom on end of the forward clutch hub. When forward clutch is seated it will be approximately 1-1/4" from pump face in case.

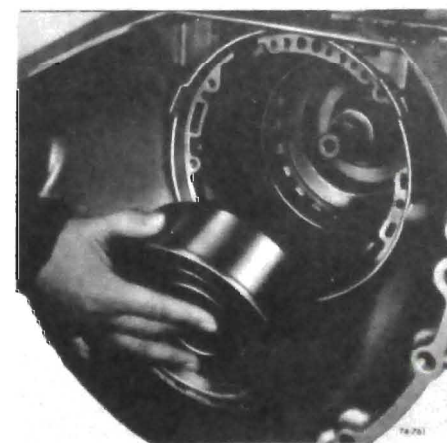

Figure 76-761

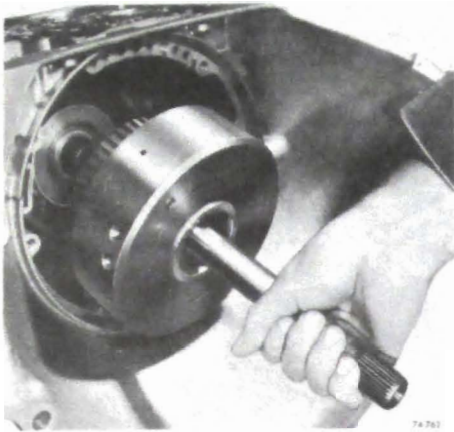

Figure 76-762

19. Install guide pins into transmission case. See Figure 76-763.

20. Install the front pump assembly, gasket and pump and all but one attaching bolt and seal. *Always use new seal on bolt.* Torque 15-20 lb. ft.

**NOTE: If the turbine shaft can not be rotated as the pump is being pulled into place, the forward or direct clutch housings have not been properly installed to index with all the clutch plates. This condition must be corrected before the pump is pulled fully into place.**

21. If necessary, install a new front seal, using Tool J-21359, to drive the seal in place. See Figure 76-764.

22. Check front unit end play as follows: See Figure 76-765.

a. Remove one front pump attaching bolt, and bolt seal.

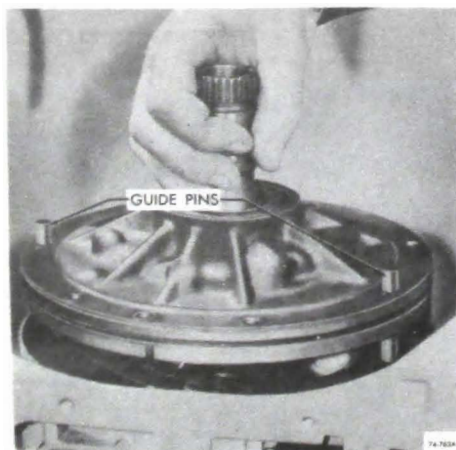

Figure 76-763

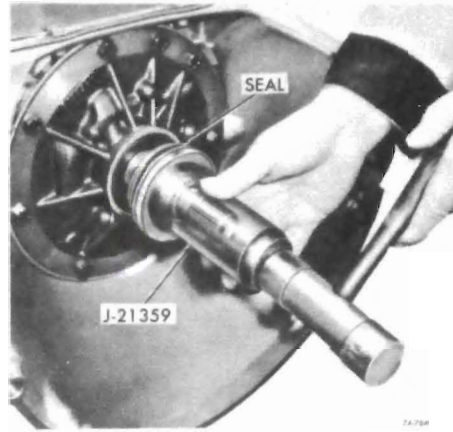

Figure 76-764

b. Install J-7004, Slide Hammer into bolt hole.

c. Mount the dial indicator on the rod and index indicator to register with end of turbine shaft.

d. Push turbine shaft rearward.

e. Push output shaft forward.

f. Set dial indicator to zero.

g. Pull turbine shaft forward.

Read the resulting travel or end play which should be .003" - .024".

The selective washer controlling this end play is the washer located between the pump cover and the forward clutch housing. If more or less washer thickness is required to bring end play within specifications, select the proper washer from the chart below.

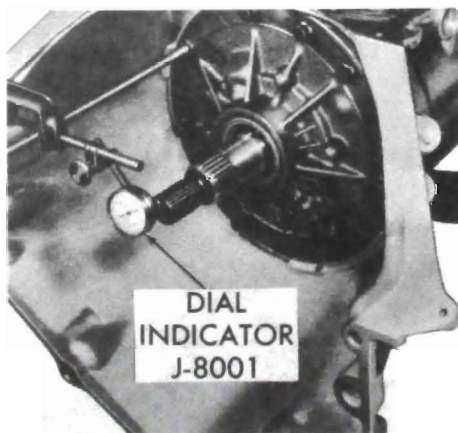

Figure 76-765

Thickness	Color
.060-.064	Yellow
.071-.075	Blue
.082-.086	Red
.093-.097	Brown
.104-.108	Green
.115-.119	Black
.126-.130	Purple

**NOTE: An oil soaked washer may tend to discolor so that it will be necessary to measure the washer for its actual thickness.**

23. Install the remaining front pump attaching bolt and new seal. Torque bolts to 15-20 lb. ft.

### 76-26 REAR EXTENSION HOUSING

1. Install the extension housing to case gasket on the extension housing.

2. Attach the extension housing to the case using attaching bolts. Torque bolts to 20-25 lb. ft.

3. If necessary, install a new rear seal, using Seal Installer Tool J-21464. See Figure 76-766.

### 76-27 INSTALLATION MANUAL LINKAGE

1. If necessary, install a new manual shaft to case lip seal using a 3/4" diameter rod to seat seal in case.

2. If removed, insert the actuator rod into manual detent lever from side opposite pin.

3. Install the actuator rod plunger under the parking bracket and over the parking pawl.

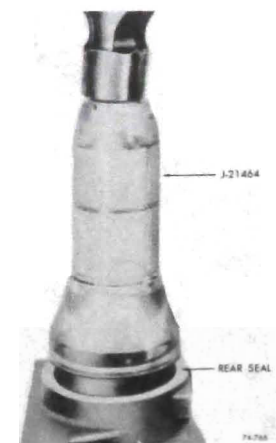

Figure 76-766



Figure 76-767

4. Install the manual shaft through the case and detent lever. See Figure 76-767.

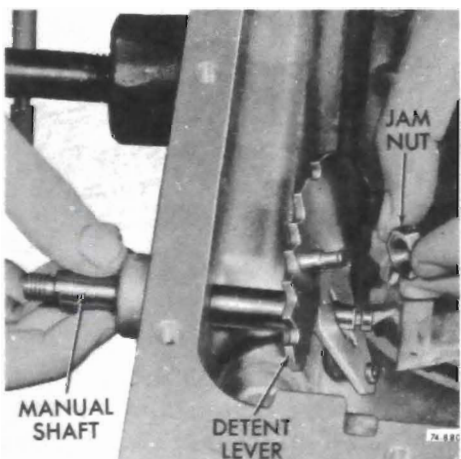

Figure 76-768

5. Install retaining hex-lock nut on manual shaft. See Figure 76-768.

6. Install manual shaft retaining pin

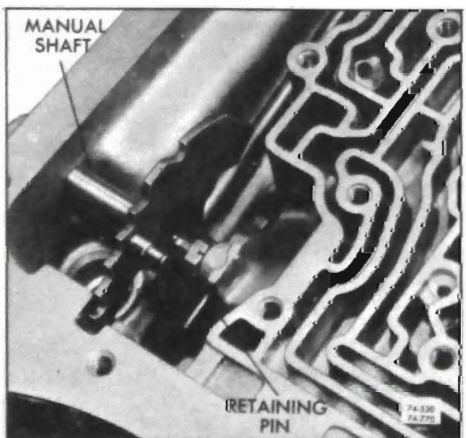

Figure 76-770

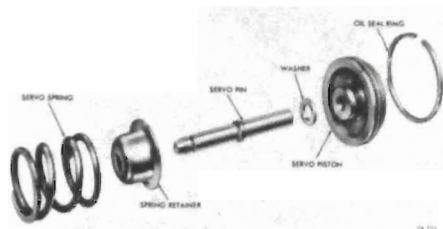

Figure 76-771

indexing with groove in manual shaft. See Figure 76-770.

**NOTE:** It may be necessary to bend pin to install. Straighten pin as it is installed.

7. Tighten lock nut on manual shaft.

#### 76-28 INSTALLATION OF CHECK BALLS, FRONT SERVO, GASKETS, SPACER AND SOLENOID

1. Install front servo spring and retainer into the transmission case. See Figure 76-771.

2. Install flat washer on front servo pin on end opposite taper.

3. Install pin and washer into case so that tapered end is contacting band.

4. Install oil seal ring on front servo

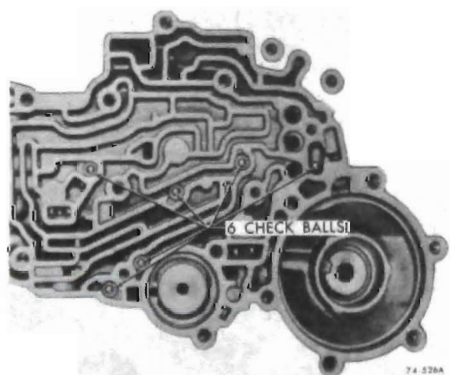

Figure 76-772

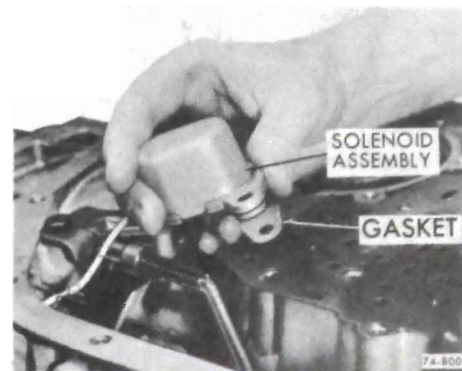

Figure 76-773

piston if removed, and install on apply pin so that identification numbers on shoulders are positioned toward bottom pan. See Figure 76-771.

5. Check freeness of piston by stroking piston in bore.

6. Install six (6) check balls into transmission case pockets. See Figure 76-772.

7. Install valve body spacer plate to case gasket. (Gasket with extension for solenoid).

8. Install valve body to case spacer plate.

9. Install solenoid gasket. See Figure 76-773.

10. Install solenoid assembly with connector facing outer edge of case, using attaching bolts.



Figure 76-774

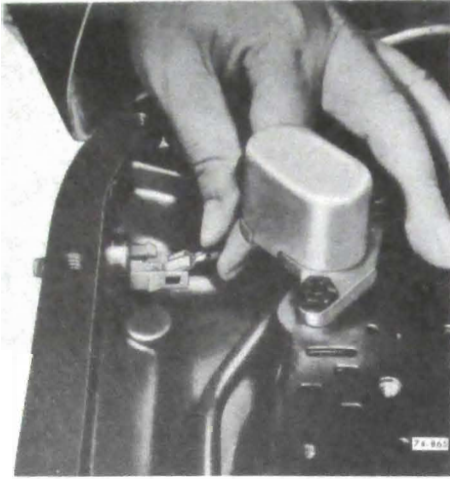

Figure 76-775

**NOTE: Do not tighten bolts at this time.**

11. Install "O" ring seal on the solenoid connector.

12. Install connector with lock tabs facing into case, positioning locator tab in notch on side of case. See Figure 76-774.

13. Install detent wire into case connector. See Figure 76-775.

**NOTE: Check by pulling on detent connector wire. If detent connector wire can be removed, turn wire connector over and reinstall into connector. See Figure 76-775.**

### 76-29 INSTALLATION OF REAR SERVO ASSEMBLY

1. Install rear servo accumulator spring into case.



Figure 76-776



Figure 76-777

2. Install rear servo assembly into case. See Figure 76-776.

3. Install rear servo gasket and cover. See Figure 76-777.

4. Install attaching bolts. Torque bolts to 15-20 lb. ft. See Figure 76-780.

### 76-30 INSTALLATION OF VALVE BODY ASSEMBLY AND GOVERNOR PIPES

1. Install valve body to spacer plate gasket. See Figure 76-781.

2. Install governor pipes into valve body assembly. See Figure 76-782.

3. Install two guide pins (control valve assembly attaching bolts with heads removed). See Figure 76-783.

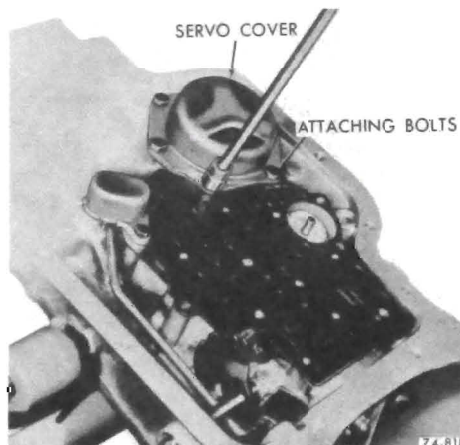

Figure 76-780

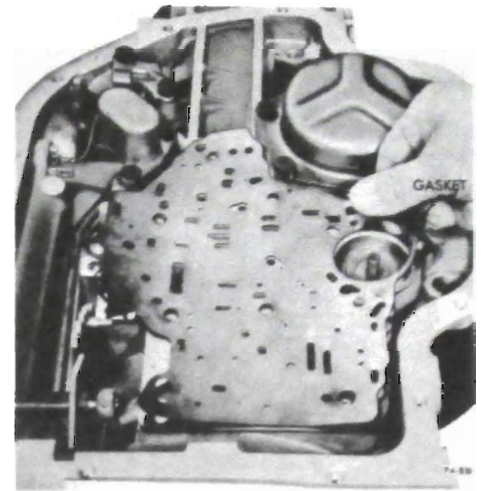

Figure 76-781

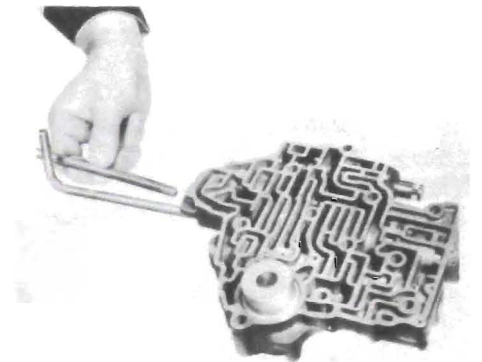

Figure 76-782

4. Install control valve assembly and governor pipes. See Figure 76-783.

**NOTE: Make certain manual valve is properly indexed with pin on detent lever and governor pipes are properly installed in case.**

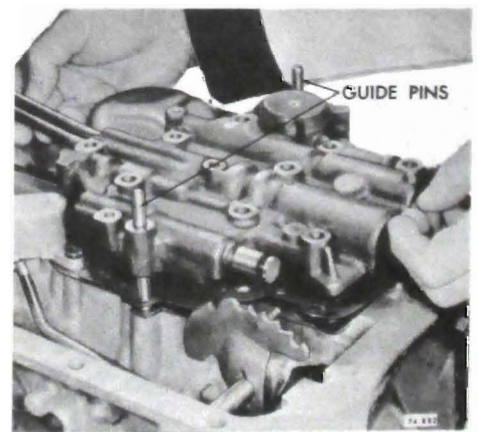

Figure 76-783

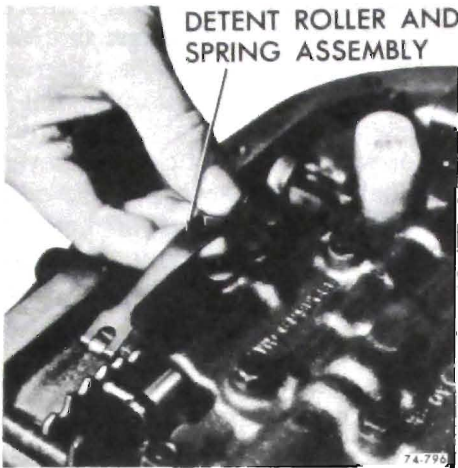

Figure 76-784

5. Remove guide pins.
6. Install control valve assembly attaching bolts and detent roller and spring assembly. Center roller on detent lever. See Figure 76-784.
7. Tighten solenoid and valve body attaching bolts. Torque bolts to 6-10 lb. ft.

### 76-31 INSTALLATION OF OIL FILTER

1. Install new case to intake pipe "O" ring on intake pipe and new filter assembly. See Figure 76-785.
2. Install filter and intake pipe assembly attaching filter to valve body assembly with retainer bolt. Torque to 10 lb. ft. See Figure 76-786.

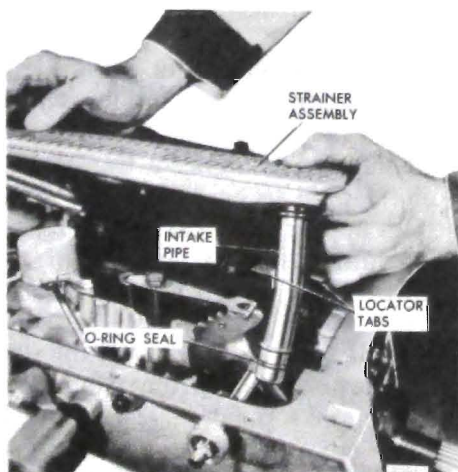

Figure 76-785

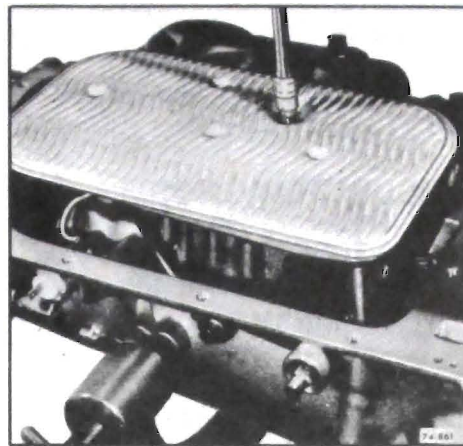

Figure 76-786

3. Install a new pan gasket on oil pan. Install attaching bolts and torque 10-13 lb. ft.

### 76-32 INSTALLATION OF MODULATOR VALVE AND VACUUM MODULATOR

1. Install modulator valve into the case, stem end out. See Figure 76-787.
2. Install the "O" ring seal on the vacuum modulator.
3. Install the vacuum modulator into the case.
4. Install the modulator retainer and attaching bolt. Torque bolt to 15-20 lb.ft. See Figure 76-788.



Figure 76-787

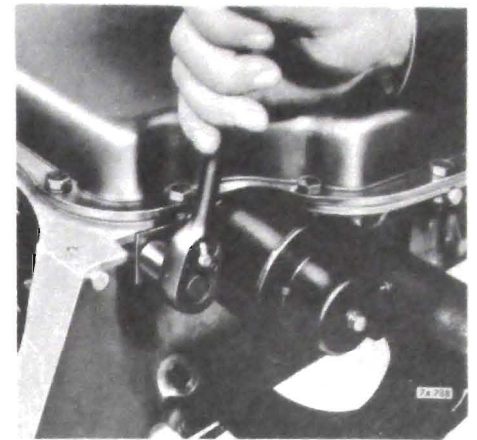

Figure 76-788

### 76-33 INSTALLATION OF GOVERNOR ASSEMBLY

1. Install governor assembly into case. See Figure 76-790.
2. Attach the governor cover and new gasket with four (4) attaching bolts. Torque bolts to 10-20 lb.ft. See Figure 76-791.

### 76-34 INSTALLATION OF SPEEDOMETER DRIVEN GEAR ASSEMBLY AND CONVERTER ASSEMBLY

1. Install the speedometer driven gear assembly. See Figure 76-792.
2. Install the speedometer driven gear retainer and attaching bolt. See Figure 76-793.

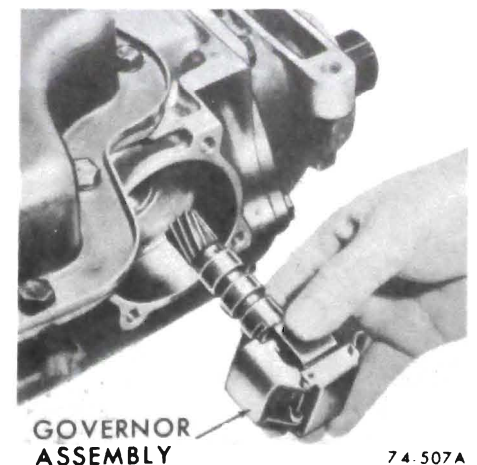
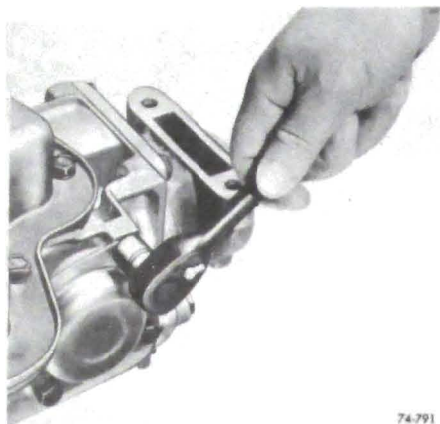

Figure 76-790





74-791

Figure 76-791

3. Install converter assembly into oil pump. Extreme care must be taken not to damage seal.



74-792

Figure 76-792

**NOTE:** Make certain converter hub drive tangs are fully engaged with pump drive gear tang.

4. Install Converter Holding Tool

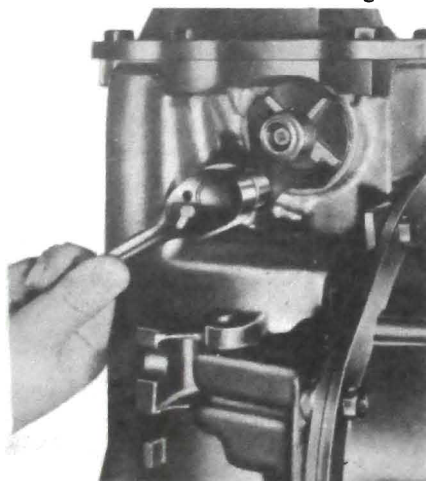

Figure 76-793

J-21366 to retain converter until ready to install in car.

## DIVISION IV

### TROUBLE DIAGNOSIS

#### 76-35 SEQUENCE FOR TURBO HYDRA-MATIC 400 TRANSMISSION DIAGNOSIS

1. Check and correct oil level.
2. Check detent switch.
3. Check and correct vacuum line and fittings.
4. Check and correct manual linkage. See Group 73.
5. Install oil pressure gage.
6. Road test car.
  - a. Road test using all selective ranges, noting when discrepancies in operation or oil pressure occur.
  - b. Attempt to isolate the unit or circuit involved in the malfunction.
  - c. If engine performance indicates an engine tune-up is required, this should be performed before road testing is completed or transmission correction attempted. Poor engine performance can result in rough shifting or other malfunctions.

#### 76-36 TURBO HYDRA-MATIC 400 TRANSMISSION OIL CHECKING PROCEDURES

Before diagnosis of any transmission complaint is attempted, there must be an understanding of oil checking procedures and what appearance the oil should have. Many times a transmission malfunction can be traced to low oil level, improper reading of dipstick, or oil appearance; therefore, a careful analysis of the condition of oil and the level may eliminate needless repairs.

When checking oil level in the

Turbo Hydra-matic 400, the procedure outlined in Paragraph 76-1, subparagraph c should be observed to obtain the most accurate reading.

Also, when the dipstick is removed, it should be noted whether the oil is devoid of air bubbles or not. Oil with air bubbles gives an indication of an air leak in the suction lines, which can cause erratic operation and slippage. Water in the oil imparts a milky, pink cast to the oil and can cause slipping.

#### 76-37 EXTERNAL OIL LEAKS

##### a. Determining Source of Oil Leak

Before attempting to correct an oil leak, the actual source of the leak must be determined. In many cases, the source of the leak can be deceiving due to "wind flow" around the engine and transmission.

The suspected area should be wiped clean of all oil before inspecting for the source of the leak. Red dye is used in the transmission oil at the assembly plant and will indicate if the oil leak is from the transmission.

The use of a "Black Light"\* to locate the point at which the oil is leaking is helpful. Comparing the oil from the leak to that on the engine or transmission dipstick, when viewed by black light, will determine the source of the leak - engine or transmission.

Oil leaks around the engine and transmission are generally carried toward the rear of the car by the air stream. For example, a transmission oil fill pipe to case leak will sometimes appear as a leak at the rear of the transmission. In determining the source of a leak, proceed as follows:

\*A "BLACK LIGHT" testing unit can be obtained from your local service tool supplier.

1. Degrease underside of transmission.

2. Road test to get unit at operating temperature. (1800F)

3. Inspect for leak with engine running.

4. With engine off, check for oil leaks due to the raised oil level caused by drain back.

#### b. Possible Points of Oil Leaks

##### 1. Transmission Oil Pan Leak

a. Attaching bolts not correctly torqued.

b. Improperly installed or damaged pan gasket.

c. Oil pan gasket mounting face not flat.

##### 2. Rear Bearing Retainer

a. Attaching bolts not correctly torqued.

b. Rear seal assembly damaged or improperly installed.

c. Extension to case, gasket damage or improperly installed.

d. Porous casting. See paragraph c.

##### 3. Case Leak

a. Filler pipe "O" ring seal damaged or missing; misposition of filler pipe bracket to engine "loading" one side of "O" ring.

b. Modulator assembly "O" ring seal damaged or improperly installed.

c. Solenoid connector "O" ring seal damaged or improperly installed.

d. Governor cover bolts not torqued, gasket damaged or leak between case face and gasket.

e. Speedometer gear "O" ring damaged.

f. Manual shaft lip seal damaged or improperly installed.

g. Parking pawl shaft cup plug damaged, improperly installed.

h. Line pressure band release tap plug loose.

i. Vent pipe (refer to item 5).

j. Porous casting. See subparagraph c.

k. Parking pawl shaft cup plug - damaged, improperly installed.

##### 4. Leak at Front of Transmission

a. Front pump seal leaks.

(1) Seal lip cut. Check converter hub for nicks, etc.

(2) Bushing moved forward and damaged.

(3) Garter spring missing from seal.

b. Front pump attaching bolts loose or bolt seals damaged or missing.

c. Front pump housing "O" ring damaged or cut.

d. Converter leak in weld area.

e. Porous casting (pump).

##### 5. Oil Comes Out Vent Pipe

a. Transmission over-filled.

b. Water in oil.

c. Foreign matter between pump and case or between pump cover and body.

d. Case - porous, front pump cover mounting face shy of stock near breather. See subparagraph c.

e. Pump to case gasket mispositioned.

f. Incorrect dipstick.

g. Cut "O" ring or grommet on filter.

h. Pump - shy of stock on mounting faces, porous casting, breather hole plugged in pump cover.

#### c. Case Porosity Repair

Turbo Hydra-Matic 400 transmission leaks caused by case porosity have successfully been repaired with the transmission in the car by using the following recommended procedures:

1. Road test and bring the transmission to operating temperature, approximately 1800.

2. Raise car on a hoist or jack stand, engine running and locate source of oil leak. See subparagraph b.

**NOTE: Use of a mirror is helpful in finding leaks.**

3. Shut engine off and thoroughly clean area to be repaired with a cleaning solvent and a brush air dry.

**NOTE: A clean, dry soldering acid brush can be used to clean the area and also to apply the epoxy cement.**

4. Using instructions of the manufacturer, mix a sufficient amount of epoxy, Group 0.423, Part No. 1360016, to make repair. **NOTE: Observe cautions of mfg. in handling.**

5. While the transmission case is still HOT, apply the epoxy to the area to be repaired.

**NOTE: Make certain the area to be repaired is fully covered.**

6. Allow cement to cure for 3 hours before starting engine.

7. Road test and check for leaks.

## 76-38 TURBO HYDRA-MATIC 400 TROUBLE DIAGNOSIS CHART

Problem	Possible Cause	Possible Condition
<b>I. NO DRIVE IN DRIVE RANGE — (INSTALL PRESSURE GAGE).</b>	<b>A. Low Oil Level</b>	1. Correct level—check for external leaks or defective vacuum modulator (leaking diaphragm will evacuate oil from unit).
	<b>B. Manual Linkage Adjustment</b>	1. See Section 73.
	<b>C. Low Oil Pressure — (Refer to par. 76-40)</b>	1. Strainer Assembly — “O” ring missing or damaged, neck weld leaking, strainer blocked. 2. Pump Assembly — Pressure Regulator, pump drive gear — tangs damaged by converter. 3. Case — porosity in intake bore.
	<b>D. Control Valve Assembly</b>	1. Manual valve disconnected from manual lever.
	<b>E. Forward Clutch</b>	1. Forward clutch does not apply—piston cracked; seals missing, damaged; clutch plates burned. 2. Pump feed circuit to forward clutch oil seal rings missing or broken on pump cover; leak in feed circuits; pump to case gasket mispositioned or damaged. Clutch drum ball check stuck or missing.
	<b>F. Roller Clutch Assembly</b>	1. Broken spring or damaged cage.
<b>II. OIL PRESSURE HIGH or LOW (SEE OIL PRESSURE CHECK) Paragraph 76-40.</b>	<b>A. High Oil Pressure</b>	1. Vacuum line or fittings leaking. 2. Vacuum modulator. 3. Modulator valve. 4. Pressure regulator. 5. Oil Pump.
	<b>B. Low Oil Pressure</b>	1. Vacuum line or fittings obstructed. 2. Vacuum modulator.

## 76-38 TURBO HYDRA-MATIC 400 TROUBLE DIAGNOSIS CHART (Cont'd.)

Problem	Possible Cause	Possible Condition
II. OIL PRESSURE HIGH or LOW (SEE OIL PRESSURE CHECK) Paragraph 76-40. (Cont'd.)	B. Low Oil Pressure (Cont'd.)	<ol style="list-style-type: none"> <li>3. Modulator valve.</li> <li>4. Pressure regulator.</li> <li>5. Governor.</li> <li>6. Oil pump.</li> </ol>
III. 1-2 SHIFT — FULL THROTTLE ONLY.  *See paragraph 76-37 subparagraph c.	A. Detent Switch. See Figures 120-59 and 120-68 for wiring diagrams.	<ol style="list-style-type: none"> <li>1. Sticking or defective (See Figure 74-201).</li> </ol>
	B. Detent Solenoid	<ol style="list-style-type: none"> <li>1. Loose.</li> <li>2. Gasket leaking.</li> <li>3. Sticks open.</li> </ol>
	C. Control Valve Assembly	<ol style="list-style-type: none"> <li>1. Valve body gaskets — leaking, damaged, incorrectly installed.</li> <li>2. Detent valve train stuck.</li> <li>3. 3-2 valve stuck.</li> </ol>
	D. Case Assembly	<ol style="list-style-type: none"> <li>1. Porosity.*</li> </ol>
IV. FIRST SPEED ONLY, NO 1-2 SHIFT.	A. Governor Assembly	<ol style="list-style-type: none"> <li>1. Governor valve sticking.</li> <li>2. Driven gear loose, damaged or worn, (check for pin in case and length of pin showing); also check output shaft drive gear for nicks or rough finish, if driven gear shows damage.</li> </ol>
	B. Control Valve Assembly	<ol style="list-style-type: none"> <li>1. 1-2 shift valve train stuck closed.</li> <li>2. Governor feed channels blocked, leaking, pipes out of position.</li> <li>3. Valve body gaskets — leaking, damaged, incorrectly installed.</li> </ol>
	C. Case	<ol style="list-style-type: none"> <li>1. Intermediate clutch plug leaking or blown out.</li> <li>2. Porosity between channels.</li> <li>3. Governor feed channel blocked, governor bore scored or worn allowing cross pressure leak.</li> </ol>

## 76-38 TURBO HYDRA-MATIC 400 TROUBLE DIAGNOSIS CHART (Cont'd.)

Problem	Possible Cause	Possible Condition
IV. FIRST SPEED ONLY, NO 1-2 SHIFT (Cont'd.)	D. Intermediate Clutch	<ol style="list-style-type: none"> <li>1. Clutch piston seals—missing, improperly assembled, cut.</li> <li>2. Center support — oil rings missing, broken, defective — orifice plug missing.</li> </ol>
V. FIRST AND SECOND SPEEDS ONLY, NO 2-3 SHIFT.	A. Detent Solenoid	<ol style="list-style-type: none"> <li>1. Stuck open (Detent shifts only—the 2-3 shift would occur at very high speeds, being interpreted as no 2-3 shifts).</li> <li>1. Refer to Figure 76-201.</li> </ol>
	B. Detent Switch. See Figures 120-59 and 120-68 for wiring diagrams.	
	C. Control Valve Assembly	<ol style="list-style-type: none"> <li>1. 2-3 shift train stuck.</li> <li>2. Valve body gaskets — leaking, damaged, incorrectly installed.</li> </ol>
	D. Direct Clutch	<ol style="list-style-type: none"> <li>1. Center support — oil rings missing, broken, defective.</li> <li>2. Clutch piston seals—missing, improperly assembled, cut, piston ball check stuck or missing.</li> </ol>
VI. DRIVE IN NEUTRAL.	A. Manual Linkage	<ol style="list-style-type: none"> <li>1. Maladjusted.</li> </ol>
	B. Forward Clutch	<ol style="list-style-type: none"> <li>1. Clutch does not release — (this condition will also cause "No Reverse").</li> </ol>
VII. NO DRIVE IN REVERSE. or SLIPS IN REVERSE — (Install Pressure Gage).	A. Low Oil Level	<ol style="list-style-type: none"> <li>1. Add oil — See Paragraph 76-1 Subparagraph c.</li> </ol>
	B. Manual Linkage	<ol style="list-style-type: none"> <li>1. Misadjusted. Refer to Group 73.</li> </ol>
	C. Oil Pressure — (Refer to par. 76-40)	<ol style="list-style-type: none"> <li>1. Vacuum modulator assembly — defective.</li> <li>2. Vacuum modulator valve — sticking.</li> <li>3. Restricted strainer leak at intake pipe grommet, or "O" ring.</li> </ol>

## 76-38 TURBO HYDRA-MATIC 400 TROUBLE DIAGNOSIS CHART (Cont'd.)

Problem	Possible Cause	Possible Condition
VII. NO DRIVE IN REVERSE, or SLIPS IN REVERSE — (Install Pressure Gage) (Cont'd.)	C. Oil Pressure — (Refer to par. 76-40) (Cont'd.)	4. Pump assembly — regulator or boost valve sticking.
	D. Control Valve Assembly	<ol style="list-style-type: none"> <li>1. Valve body gaskets — leaking, damaged, incorrectly installed (Other malfunctions may also be indicated).</li> <li>2. Low Reverse ball check — missing from case (This will also cause no overrun braking in L<sup>1</sup> Range).</li> <li>3. 2-3 Valve train stuck open (This will also cause 1-3 upshift in Drive Range).</li> <li>4. Reverse feed passage — missing check case passages.</li> </ol>
	E. Rear Servo and Accumulator	<ol style="list-style-type: none"> <li>1. Servo piston seal ring, damaged or missing.</li> <li>2. Short band apply pin (This may also cause no overrun braking or slips in overrun braking — L<sup>1</sup> Range).</li> </ol>
	F. Reverse or Low Band	1. Burned, loose lining, apply pin or anchor pins not engaged, band broken.
	G. Direct Clutch	<ol style="list-style-type: none"> <li>1. Outer seal damaged or missing.</li> <li>2. Clutch plates burned — may be caused by stuck ball check in piston.</li> </ol>
	H. Forward Clutch	1. Clutch does not release (will also cause Drive in Neutral).
VIII. SLIPS IN ALL RANGES, SLIPS ON START — (Install Pressure Gage)	A. Oil Level Low	1. Add oil — See Paragraph 76-1, subparagraph c.
	B. Oil Pressure (Refer to par. 76-40)	<ol style="list-style-type: none"> <li>1. Vacuum modulator defective.</li> <li>2. Vacuum modulator valve sticking.</li> <li>3. Strainer assembly — plugged or leaks; grommet "O" ring missing or damaged.</li> </ol>

## 76-38 TURBO HYDRA-MATIC 400 TROUBLE DIAGNOSIS CHART (Cont'd.)

Problem	Possible Cause	Possible Condition
VIII. SLIPS IN ALL RANGES, SLIPS ON START — (Install Pressure Gage) (Cont'd.)	B. Oil Pressure (Refer to par. 76-40) (Cont'd.)	4. Pump assembly — regulator or boost valve sticking, cross leak. 5. Pump to case gasket damaged or incorrectly installed.
	C. Case	1. Cross leaks, porosity.
	D. Forward and Direct Clutches Slipping	1. If burned, look for cause. 2. Oil seal rings on pump cover broken or worn.
IX. SLIPS 1-2 SHIFT — (Install Pressure Gage)	A. Oil Level Low	1. Add oil — See Paragraph 76-1, subparagraph c.
	B. Oil Pressure (Refer to par. 76-40)	1. Vacuum modulator assembly defective. 2. Modulator valve sticking. 3. Pump pressure regulator valve.
	C. Front Accumulator	1. Oil ring damaged or missing.
	D. Control Valve Assembly	1. 1-2 accumulator valve train sticking. 2. Porosity in valve body or case. 3. Valve body attaching bolts not properly torqued.
	E. Rear Accumulator	1. Oil ring missing or damaged, case bore damaged.
	F. Pump to Case Gasket	1. Mispositioned.
	G. Case	1. Intermediate clutch plug — leaking excessively. 2. Porosity between channels.
	H. Intermediate Clutch	1. Piston seals missing or damaged; clutch plates burned. 2. Center support leak in feed circuit (oil rings damaged or grooves defective), excessive leak between tower and bushing, orifice bleed plug hole (0.20 dia.) blocked. Center support bolt not seated properly in case. 3. Extra waved steel plate — should have only 1 waved steel plate. No waved plate in "BB" model.

## 76-38 TURBO HYDRA-MATIC 400 TROUBLE DIAGNOSIS CHART (Cont'd.)

Problem	Possible Cause	Possible Condition
X. ROUGH 1-2 SHIFT—(Install Pressure Gage)	A. Oil Pressure — (Refer to par. 74-40)	<ol style="list-style-type: none"> <li>1. Vacuum modulator — check for loose fittings, restrictions in line, modulator assembly defective.</li> <li>2. Modulator valve stuck.</li> <li>3. Pump—regulator or boost valve stuck.</li> <li>4. Pump to case gasket — off location or damaged.</li> </ol>
	B. Control Valve Assembly	<ol style="list-style-type: none"> <li>1. 1-2 accumulator valve train.</li> <li>2. Valve body to case bolts loose.</li> <li>3. Wrong gaskets or off location — damaged.</li> </ol>
	C. Case	<ol style="list-style-type: none"> <li>1. Intermediate clutch ball missing or not sealing.</li> <li>2. Porosity between channels.</li> </ol>
	D. Rear Servo Accumulator Assembly	<ol style="list-style-type: none"> <li>1. Oil rings damaged.</li> <li>2. Piston stuck.</li> <li>3. Broken or missing spring.</li> <li>4. Bore damaged.</li> </ol>
	E. Intermediate Clutch	<ol style="list-style-type: none"> <li>1. Extra waved steel plate. No waved plate in "BB" model.</li> </ol>
XI. SLIPS 2-3 SHIFT — (Install Pressure Gage)	A. Oil Level Low	<ol style="list-style-type: none"> <li>1. Add oil — See Paragraph 76-1, subparagraph c.</li> </ol>
	B. Oil Pressure Low — (Refer to par. 76-40)	<ol style="list-style-type: none"> <li>1. Modulator assembly.</li> <li>2. Modulator valve.</li> <li>3. Pump pressure regulator valve or boost valve; pump to case gasket off location.</li> </ol>
	C. Control Valve Assembly	<ol style="list-style-type: none"> <li>1. Accumulator piston pin—leak at swedge end.</li> </ol>
	D. Case	<ol style="list-style-type: none"> <li>1. Porosity.</li> </ol>
	E. Direct Clutch	<ol style="list-style-type: none"> <li>1. Piston seals leaking, or ball check leak.</li> <li>2. Center support — oil seal rings damaged; excessive leak between tower and bushing.</li> <li>3. Extra waved steel plate—should have only 1 waved plate. No waved plate in "BB" model.</li> </ol>



## 76-38 TURBO HYDRA-MATIC 400 TROUBLE DIAGNOSIS CHART (Cont'd.)

Problem	Possible Cause	Possible Condition
XII. ROUGH 2-3 SHIFT—(Install Pressure Gage)	A. Oil Pressure — High (Refer to par. 76-40)	1. Modulator assembly defective. 2. Modulator valve sticking. 3. Pump—pressure regulator or boost valve inoperative
	B. Front Servo Accumulator Assembly	1. Front accumulator spring missing, broken. 2. Accumulator piston stuck.
	C. Direct Clutch	1. Extra waved steel plate. No waved plate in "BB" model.
XIII. NO ENGINE BRAKING — L <sup>2</sup> — 2nd GEAR	A. Front Servo and Accumulator	1. Servo or accumulator oil rings or bores leaking. 2. Servo piston stuck.
	B. Front Band	1. Front band broken, burned (check for cause); not engaged on anchor pin and/or servo pin.
XIV. NO ENGINE BRAKING — L <sup>1</sup> — 1st GEAR	A. Control Valve Assembly	1. Lo-Reverse check ball missing from case.
	B. Rear Servo	1. Oil seal ring, bore or piston damaged; leaking apply pressure. 2. Rear band apply pin short, improperly assembled.
	C. Rear Band <b>NOTE:</b> Item A, B, C, will also cause slips in Reverse or no Reverse.	1. Rear band — broken, burned (check for cause), not engaged on anchor pins or servo pin.
XV. NO PART THROTTLE DOWNSHIFT — (INSTALL PRESSURE GAGE)	A. Oil Pressure — (Refers to Par. 76-40 For Oil Pressure Specifications)	1. Vacuum modulator assembly, modulator valve, pressure regulator valve train. (Other malfunctions may also be noticed).
	B. Control Valve Assembly	1. 3-2 valve stuck, spring missing or broken.
XVI. NO DETENT DOWNSHIFTS	A. Control Valve Assembly	1. 3-2 valve stuck, spring missing or broken.
	B. Detent Switch	1. Adjustment, connections fuse.
	C. Solenoid	1. Inoperative, connections.
	D. Control Valve Assembly	1. Detent valve train, sticking.

## 76-38 TURBO HYDRA-MATIC 400 TROUBLE DIAGNOSIS CHART (Cont'd.)

Problem	Possible Cause	Possible Condition
XVII. LOW or HIGH SHIFT POINTS — (Install Pressure Gage)	A. Oil Pressure — (Refer to par. 76-40)	<ol style="list-style-type: none"> <li>1. Engine vacuum—check at transmission end of the modulator pipe.</li> <li>2. Vacuum modulator assembly vacuum line connections at engine and transmission, modulator valve, pressure regulator valve train.</li> </ol>
	B. Governor	<ol style="list-style-type: none"> <li>1. Valve sticking.</li> <li>2. Feed holes restricted or leaking, pipes damaged or mispositioned.</li> <li>3. Feed line plugged.</li> </ol>
	C. Detent Solenoid	<ol style="list-style-type: none"> <li>1. Stuck open, loose, etc. (Will cause late shifts).</li> </ol>
	D. Control Valve Assembly	<ol style="list-style-type: none"> <li>1. Detent valve train.</li> <li>2. 3-2 valve train.</li> <li>3. 1-2 shift valve train.               <ol style="list-style-type: none"> <li>a. 1-2 regulator valve stuck—(This would cause a constant 1-2 shift point regardless of throttle opening).</li> </ol> </li> <li>4. Spacer plate gaskets — mispositioned, spacer plate orifice holes missing or blocked.</li> </ol>
	E. Case	<ol style="list-style-type: none"> <li>1. Porosity; intermediate plug leaking, missing.</li> </ol>
XVIII. WON'T HOLD IN PARK	A. Manual Linkage	<ol style="list-style-type: none"> <li>1. Maladjusted.</li> </ol>
	B. Internal Linkage	<ol style="list-style-type: none"> <li>1. Parking brake lever and actuator assembly—defective (Check for chamfer on actuator rod sleeve).</li> <li>2. Parking pawl broken or inoperative.</li> </ol>
XIX. TRANSMISSION NOISY	A. Pump Noise	<ol style="list-style-type: none"> <li>1. Oil low or high.</li> <li>2. Cavitation due to plugged strainer, "O" ring damaged, porosity in intake circuit, water in oil.</li> <li>3. Pump gears—driving gear assembled backwards, gears damaged or defective, crescent interference.</li> </ol>

## 76-38 TURBO HYDRA-MATIC 400 TROUBLE DIAGNOSIS CHART (Cont'd.)

Problem	Possible Cause	Possible Condition
XIX. TRANSMISSION NOISY (Cont'd.)	B. Gear Noise—First Gear (Drive Range)	1. Transmission grounded to body. 2. Planetary gear set.
	C. Clutch Noise — During Application	1. Forward clutch—(Neutral to Drive, Park to Drive); Check clutch plates. 2. Intermediate clutch — (1-2 shift in L <sup>2</sup> and Drive Range); Check clutch plates. 3. Direct clutch — (2-3 shift in Drive Range and in Neutral to Reverse, Park to Reverse); Check clutch plates.
	D. Converter Noise	1. This Condition will occur in R-D-L <sup>2</sup> -L <sup>1</sup> Due to damaged Needle Bearings in Converter. Noise Level is generally lower in Park and Neutral.

76-60

## 76-39 VACUUM MODULATOR DIAGNOSIS

The vacuum modulator, see Figure 76-794, has three areas to be checked. If any one of the three (3) areas fail to pass the prescribed checks, the modulator must be replaced.

## 1. Bellows Comparison Check

Using a comparison gage, furnished with Dealer Service Information Bulletin 67-I-37, one per dealer, compare the load of a known good modulator *of the same number* with the modulator in question.

**NOTE:** Refer to modulator usage chart in paragraph 76-1, subparagraph a.

To check bellows load proceed as follows:

a. Insert one end of the comparison gage into the suspected defective modulator sleeve. Insert the opposite

end of the gage into a known good modulator *of the same part number* as the suspected defective modulator.

**NOTE:** Refer to modulator usage chart in paragraph 76-1, subparagraph a.

**NOTE:** The part number of the modulator assembly is located on the back side of the modulator.

b. Holding the modulators in a horizontal position, see Figure 76-795, bring them slowly together under pressure. The modulator bellows in question, if defective, will

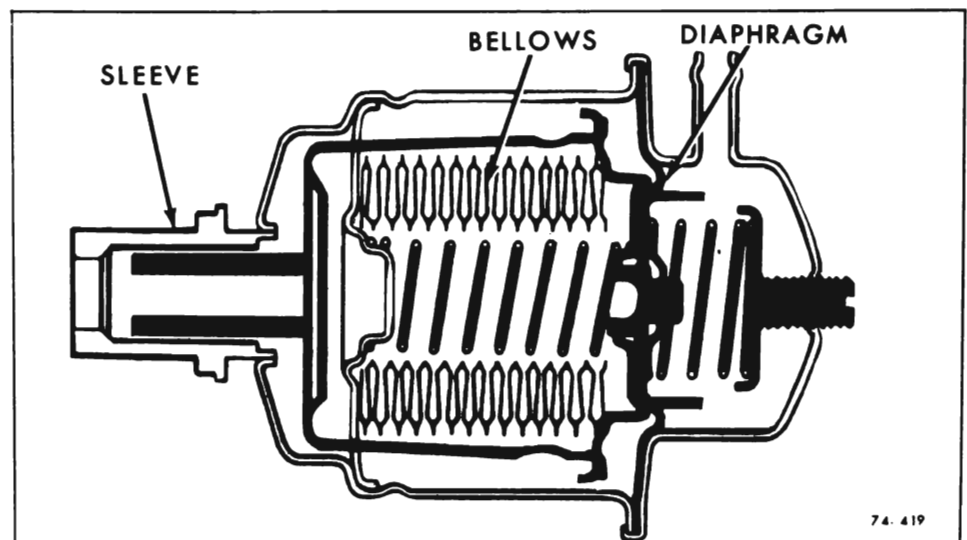

74-419

Figure 76-794 - Vacuum Modulator Assembly

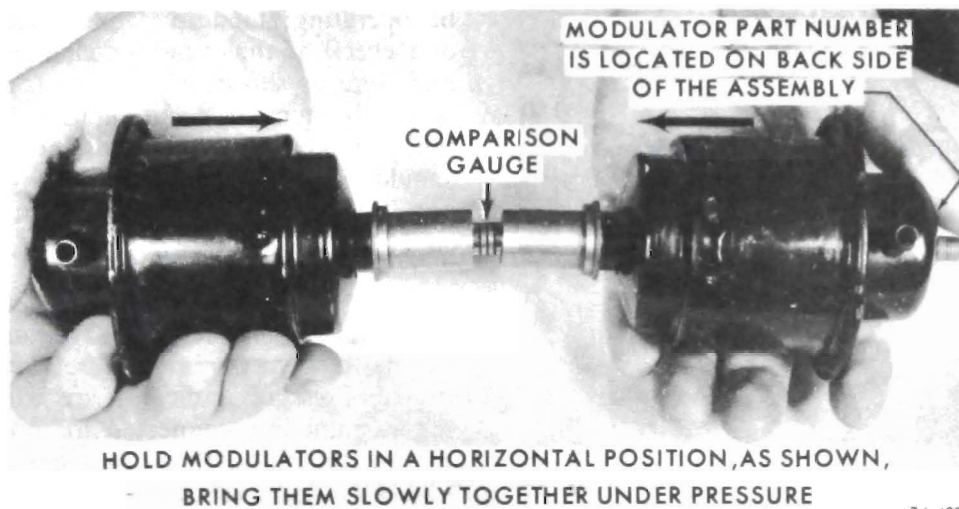

Figure 76-795 - Holding Modulators in Horizontal Position

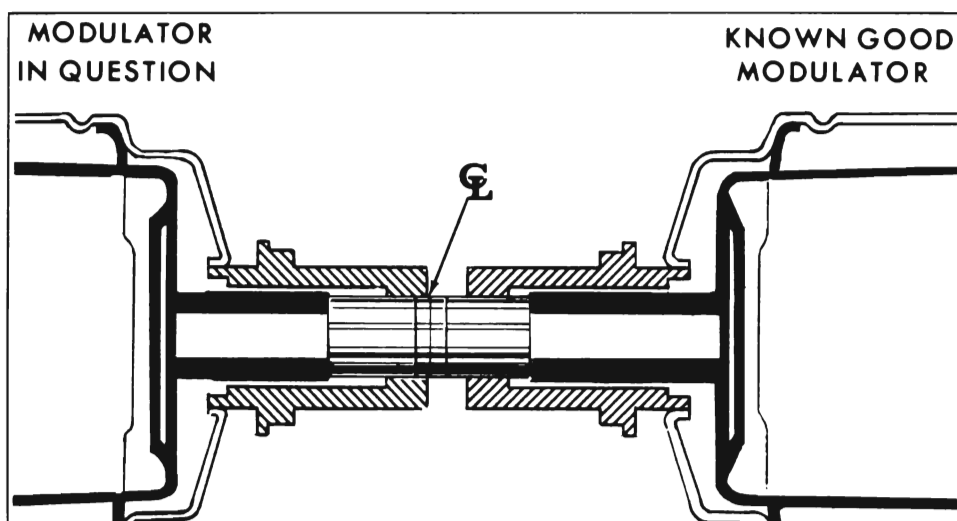

Figure 76-796 - Modulator Bellows Bad

reach the center line of the comparison gauge before the known good modulator lines up with the outer gauge line. See Figure 76-796.

If the modulator bellows in question is good, both modulator assemblies will be within the outer gauge lines as the assemblies are slowly brought together. See Figure 76-797.

## 2. Vacuum Diaphragm Leak Check

Turn modulator so vacuum line stem points downward. If transmission oil comes out the vacuum diaphragm is defective.

**IMPORTANT:** Gasoline and/or water vapor may settle in the vacuum side

of the modulator. If this is found **WITHOUT** the presence of oil the modulator **MUST NOT BE CHANGED**.

Check solution that comes out of the modulator for evidence of lubricity. If the solution does not have the feel of oiliness it can be assumed the solution is a mixture of gas and/or water. The only way transmission oil can be on the vacuum side of the modulator is by a leak in the vacuum diaphragm.

If oil is found, the modulator must be replaced. If oil is not found in the vacuum side of the modulator but the transmission oil level is continually low, and *No external leaks are found*, there is a possibility that a pin hole leak exists in the diaphragm and the modulator should be replaced.

## 3. Inspection for External Damage

1. Check for dents or cracks in modulator.

2. Check modulator valve sleeve alignment. Roll modulator on a flat surface to determine if the sleeve is concentric to the modulator can. See Figure 76-798. If the sleeve is bent, runout will be visible, and modulator must be replaced.

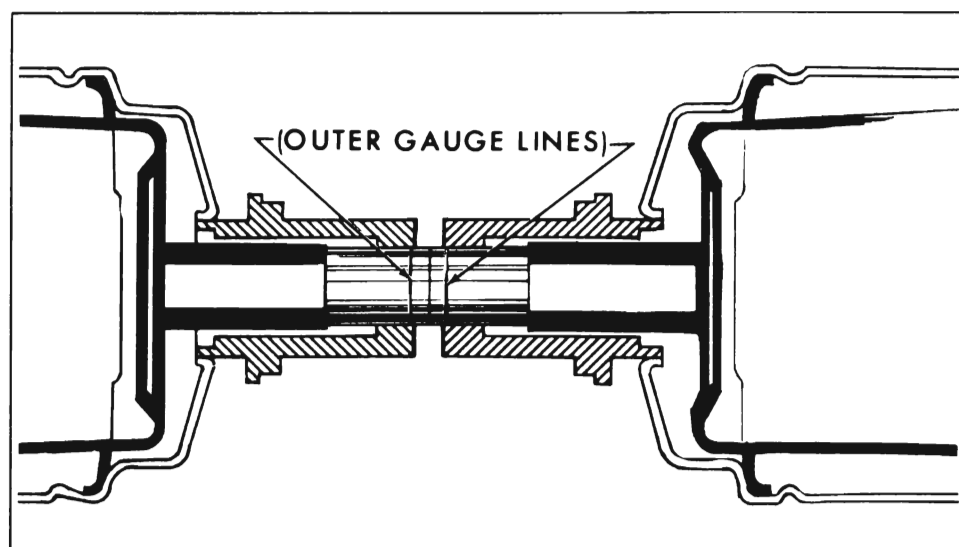

Figure 76-797 - Modulator Bellows Good

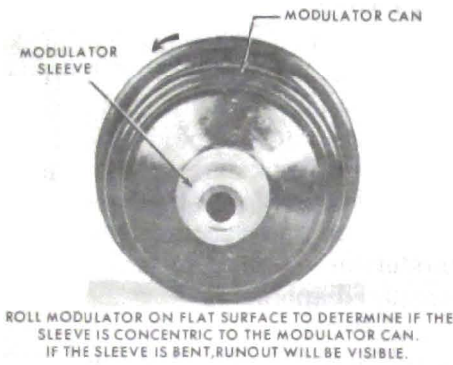

Figure 76-798 - Checking Modulator Sleeve Alignment

If the modulator passes the above checks, the following items should also be checked as a possible cause of the problem.

1. Check freeness of modulator valve in modulator.
2. Check freeness of modulator valve in transmission case.
3. Check the vacuum line from the manifold to modulator for holes, cracks or dents. Check the rubber hose connections at the modulator and at the intake manifold for leaks.

**76-40 TRANSMISSION OIL PRESSURE CHECK TURBO HYDRA-MATIC 400**

**1. Oil Pressure Check - Road or Normal Operating Conditions**

While road testing (with the transmission oil pressure gage attached and the vacuum modulator tube connected) the transmission pressures should check approximately as follows:

L <sup>2</sup> Range	Min.	Max.
2nd gear — Steady	150	150
road load	(±5) psi	(±5) psi

Gear	Selector Lever Position	Min.	Max.
1st	Drive	60	150
2nd	(Zero throttle to full throttle)	60	150
3rd	Drive Range, (Zero throttle 30 mph)	60	
Rev.	Reverse (full throttle)	220	260

**Oil Pressure Check - Vacuum Modulator Check**

The vacuum modulator assembly can be checked by making an oil pressure check as described in parts "A" and "B" of this section. The pressures given are approximate and can vary with changes in atmosphere pressure, but if this method is used as an indication of a source of malfunction, it can be a valuable service tool.

Using procedure "A" the oil pressures should be approximately as shown. Oil pressures taken in this manner, that vary appreciably from the chart, indicate further inspection of the following:

1. Vacuum lines and fittings.
2. Vacuum modulator.
3. Modulator valve.
4. Governor.
5. Pressure regulator.
6. Oil pump.

If the results of procedure "A" indicate further inspection is required, procedure "B" should be followed. If the pressures are appreciably different from those given in "B", a second check should be made with a new modulator assembly or one from a vehicle that is known to

be operating standard. On the second check, if the pressures changed and were as shown on the chart, or closer to them, it would indicate a faulty modulator assembly and it should be suspected as a cause or part of the cause of the malfunction.

**A. Car Stationary**

Transmission oil pressure gage and engine tachometer should be connected. Pressures indicated are with the vacuum line connected for normal modulator operation and service brakes holding vehicle with engine at 1000 rpm.

Drive Neutral Park	L <sup>2</sup> or L <sup>1</sup>	Reverse
60	150	95

76-63

**NOTE: Pressures are approximate.**

**B. Oil pressures indicated are at zero output speed with the vacuum line disconnected from the modulator assembly and with the engine at 1200 rpm.**

Alt. of Check (Ft. Above Sea Level)	Drive Neutral Park	L <sup>2</sup> or L <sup>1</sup>	Rev.
0	150	150	244
2,000	150	150	233
4,000	145	150	222
6,000	138	150	212
8,000	132	150	203
10,000	126	150	194
12,000	121	150	186
14,000	116	150	179

76-64

**NOTE: Altitude and pressures are approximate.**

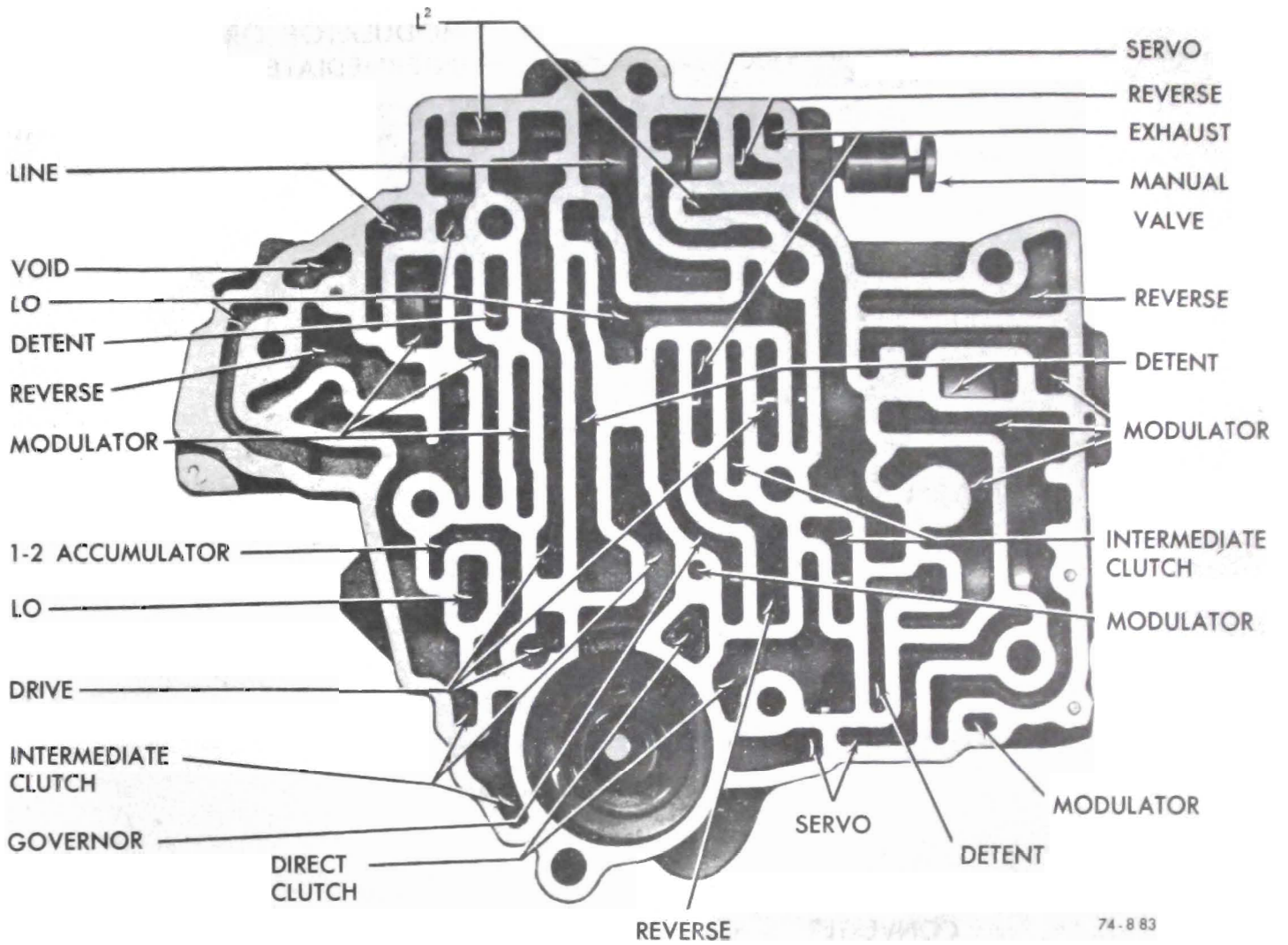

Figure 76-800 - Valve Body

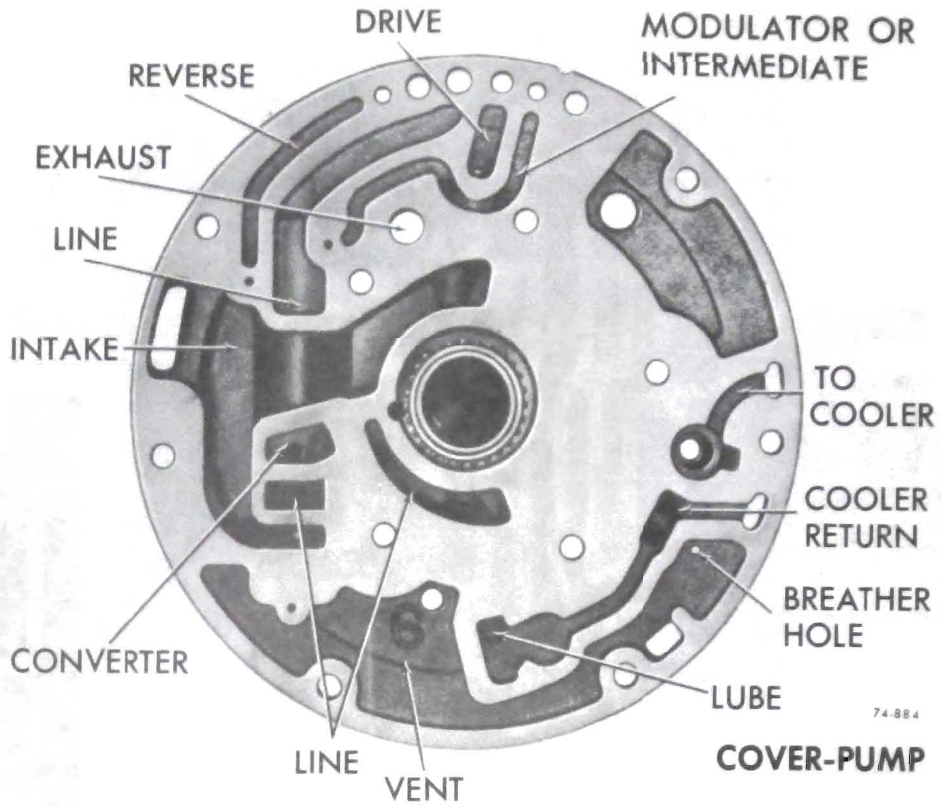

Figure 76-801 - Oil Pump Cover

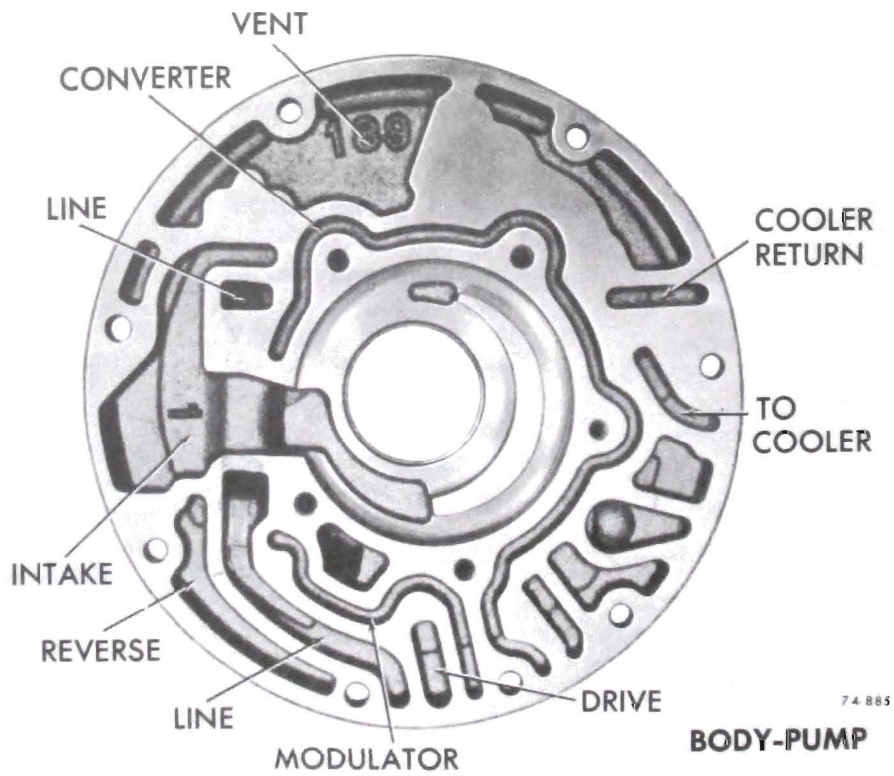
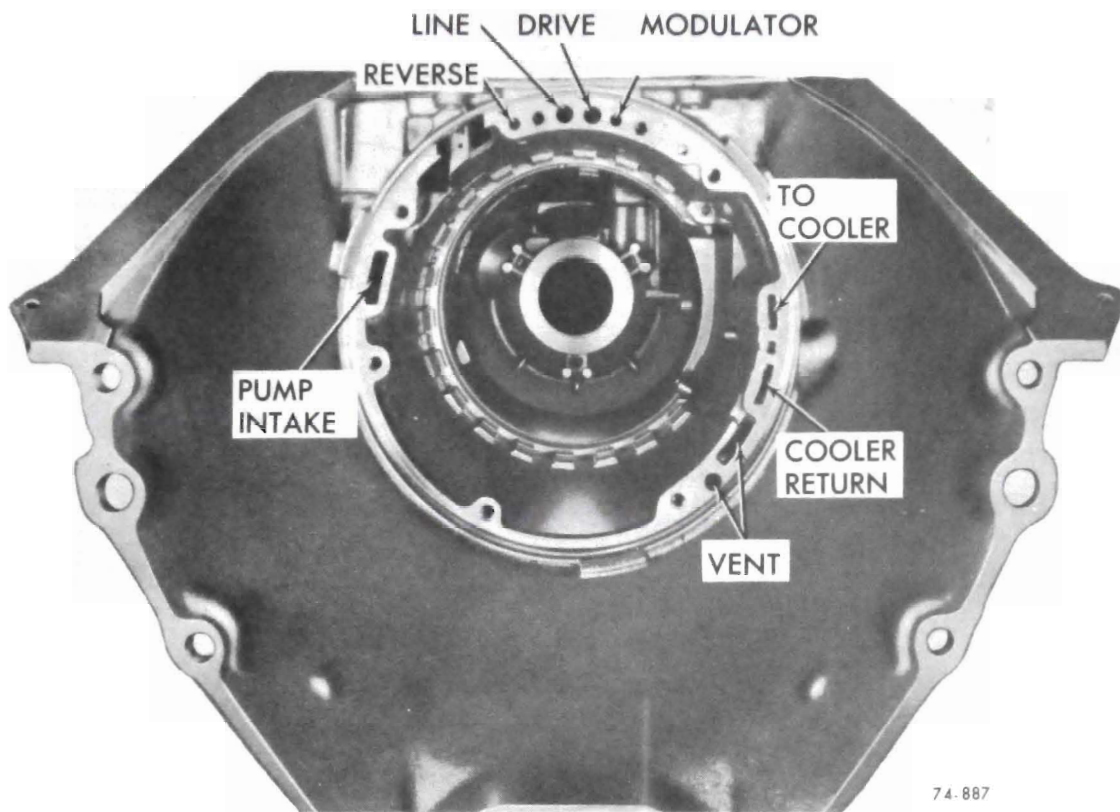
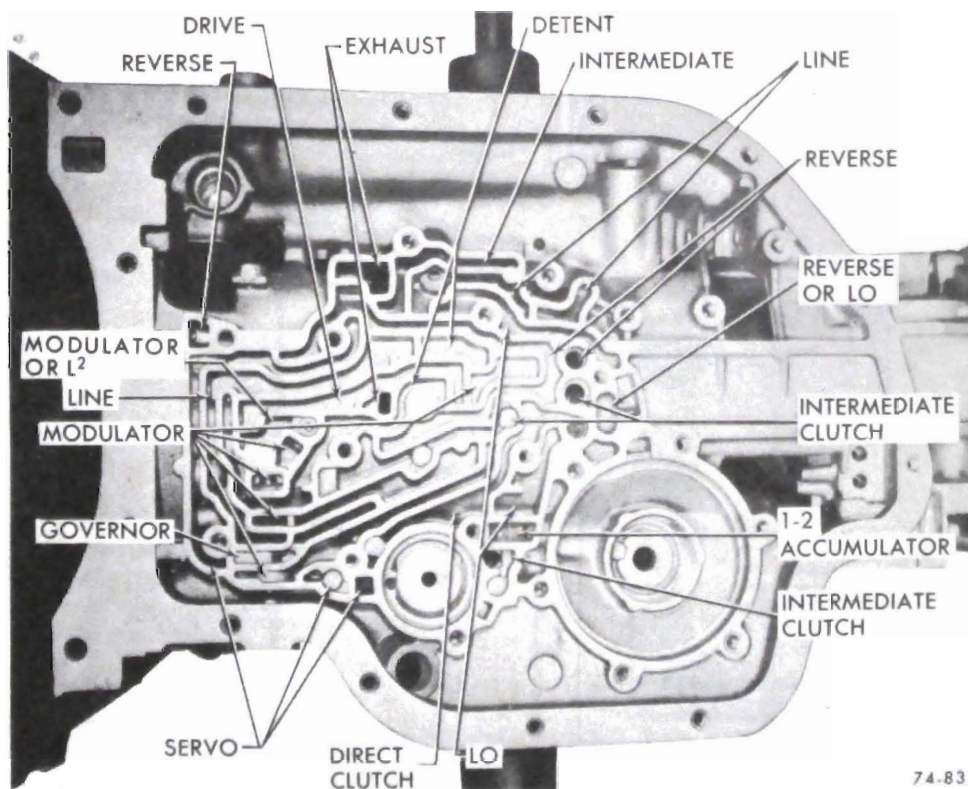

Figure 76-802 - Oil Pump Body



74-887

Figure 76-803 - Front of Case



74-831

Figure 76-804 - Bottom of Case



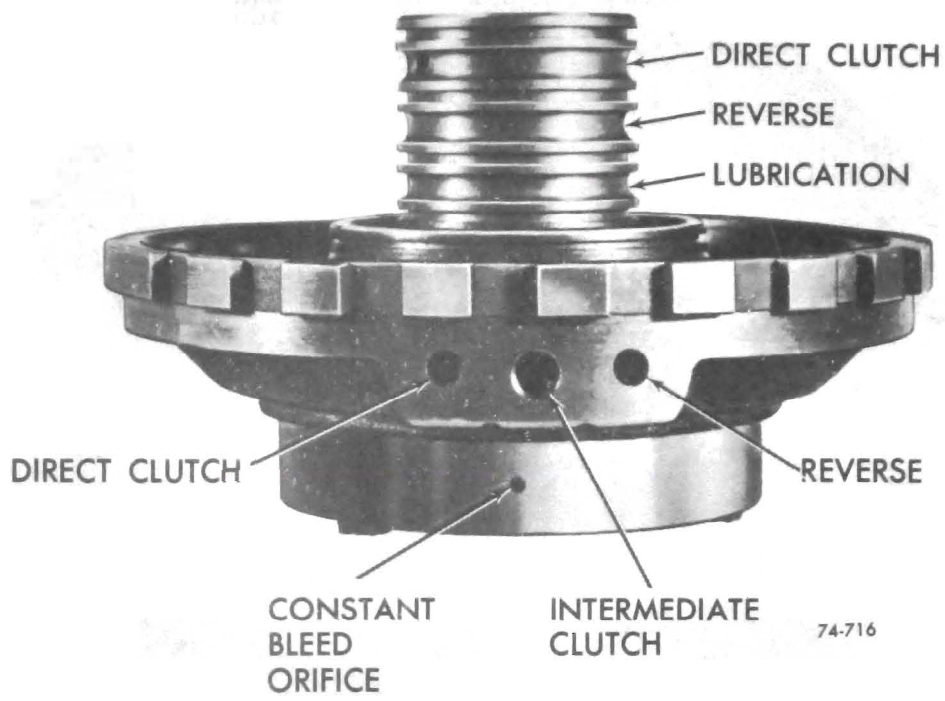

Figure 76-805 - Center Support

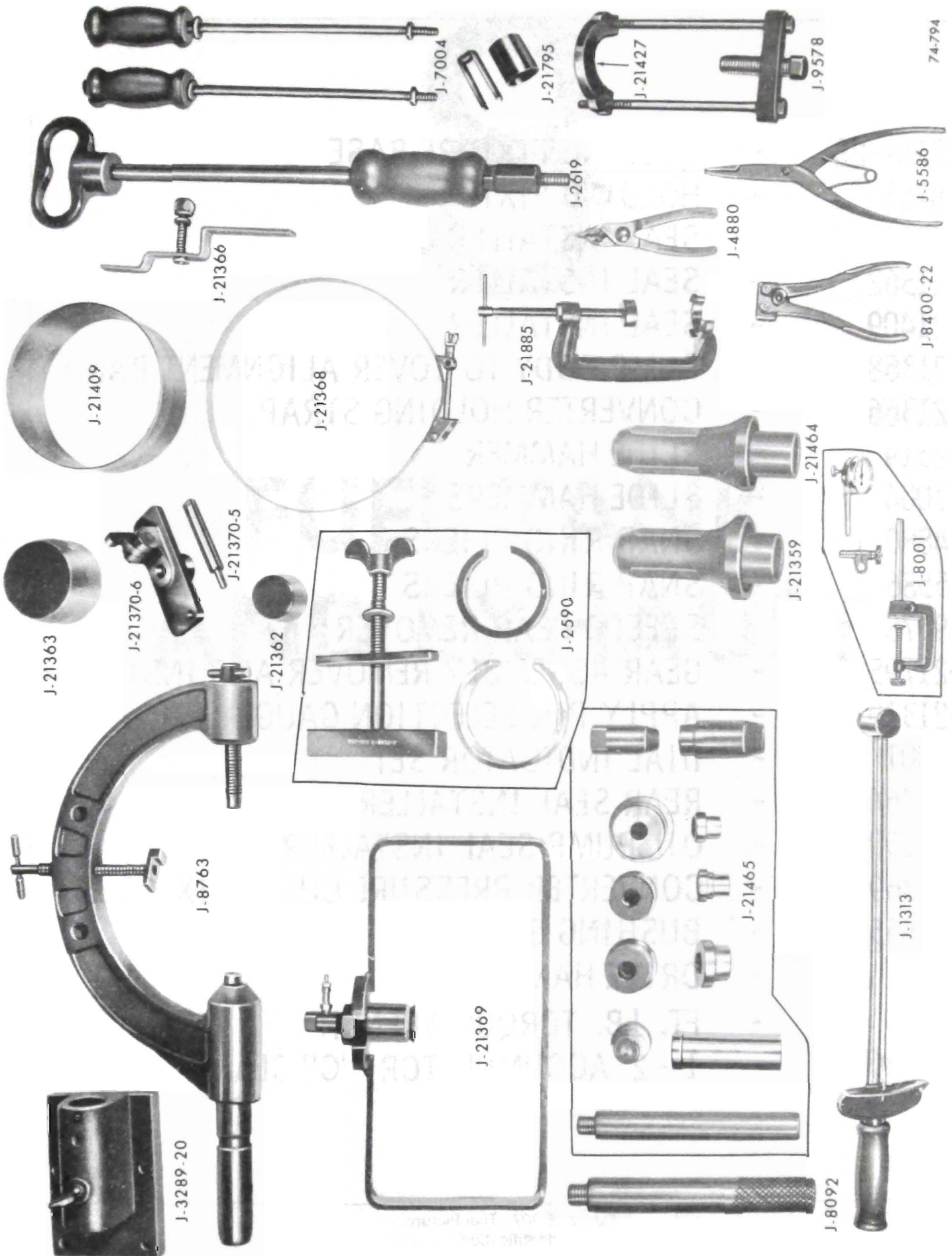

Figure 76-806 · Tool Picture

J-3289-20	-	HOLDING FIXTURE BASE
J-8763	-	HOLDING FIXTURE
J-21363	-	SEAL INSTALLER
J-21362	-	SEAL INSTALLER
J-21409	-	SEAL INSTALLER
J-21368	-	PUMP BODY TO COVER ALIGNMENT BAND
J-21366	-	CONVERTER HOLDING STRAP
J-2619	-	SLIDE HAMMER
J-7004	-	SLIDE HAMMERS
J-4880	-	SNAP RING PLIERS
J-5586	-	SNAP RING PLIERS
J-9578	-	SPEEDO GEAR REMOVER
J-21795	-	GEAR ASSEMBLY REMOVER AND INSTALLER
J-21370	-	APPLY PIN SELECTION GAUGE
J-8001	-	DIAL INDICATOR SET
J-21464	-	REAR SEAL INSTALLER
J-21359	-	OIL PUMP SEAL INSTALLER
J-21369	-	CONVERTER PRESSURE CHECK FIXTURE
J-21465	-	BUSHING SET
J-8092	-	DRIVE HANDLE
J-1313	-	FT. LB. TORQUE WRENCH
J-21885	-	1 - 2 ACCUMULATOR "C" CLAMP

74-795

Figure 76-807 - Tool Picture  
Identification