

SECTION H

46-48-49000 POSITIVE TRACTION DIFFERENTIAL

CONTENTS

Division	Subject	Paragraph
I	SPECIFICATIONS AND ADJUSTMENTS: Lubrication of Positive Traction Differential.....	40-41
II	DESCRIPTION AND OPERATION: Description of Positive Traction Differential..... Operation of Positive Traction Differential.....	40-42 40-43
III	SERVICE PROCEDURES: Positive Traction Differential Service Procedures..... Positive Traction Flushing Procedure	40-44 40-45
IV	TROUBLE DIAGNOSIS: Testing Positive Traction Differential.....	40-46

DIVISION I

SPECIFICATIONS AND ADJUSTMENTS

NOTE: All specifications and adjustments for the Positive Traction Differential are the same as are listed in Section G for standard differential. The only exception to this is the lubricant used in the Positive Traction Differential.

40-41 LUBRICATION OF POSITIVE TRACTION DIFFERENTIAL

The lubricant level should be checked every 6000 miles. Maintain level between the bottom of the filler plug opening and 1/4 inch below the opening by adding Special Positive Traction Lubricant (SAE 90 gear lube meeting specification for GM Part No. 1050081) or equivalent available through the Buick Parts Department. Never use any lubricant other than this special lubricant, even for adding.

Positive Traction Differentials can be easily identified either by a stainless steel plate attached by a rear cover bolt or by an X in a circle stamped on the bottom of the left axle tube.

For flushing procedure, see paragraph 40-45.

Capacity of the differential assembly is 4-1/4 pints.

DIVISION II

DESCRIPTION AND OPERATION

40-42 DESCRIPTION OF POSITIVE TRACTION DIFFERENTIAL

Buick Positive Traction Differential is optional equipment on all Buicks. It is designed to perform all the desirable functions of a conventional differential and at the same time overcome its limitations. With a

conventional differential, when one wheel is on a slippery surface, its pulling power is limited by the wheel with the lowest traction. Unlike the conventional differential, with the Positive Traction device, the anti-spinning action is limited by the wheel having the best traction, thus limiting the possibility of becoming stuck.

Buick Positive Traction Differential is not a fully locking type and will release before excessive driving force can be directed to one rear wheel. The safety value of this feature eliminates the possibility of dangerous steering reaction. When the rear wheels are under extremely unbalanced tractive conditions, such as having one wheel on ice and the other on dry pavement, wheel spin can occur if over-acceleration is attempted.

However, even when wheel spin does occur, the major driving force is directed to the nonspinning wheel.

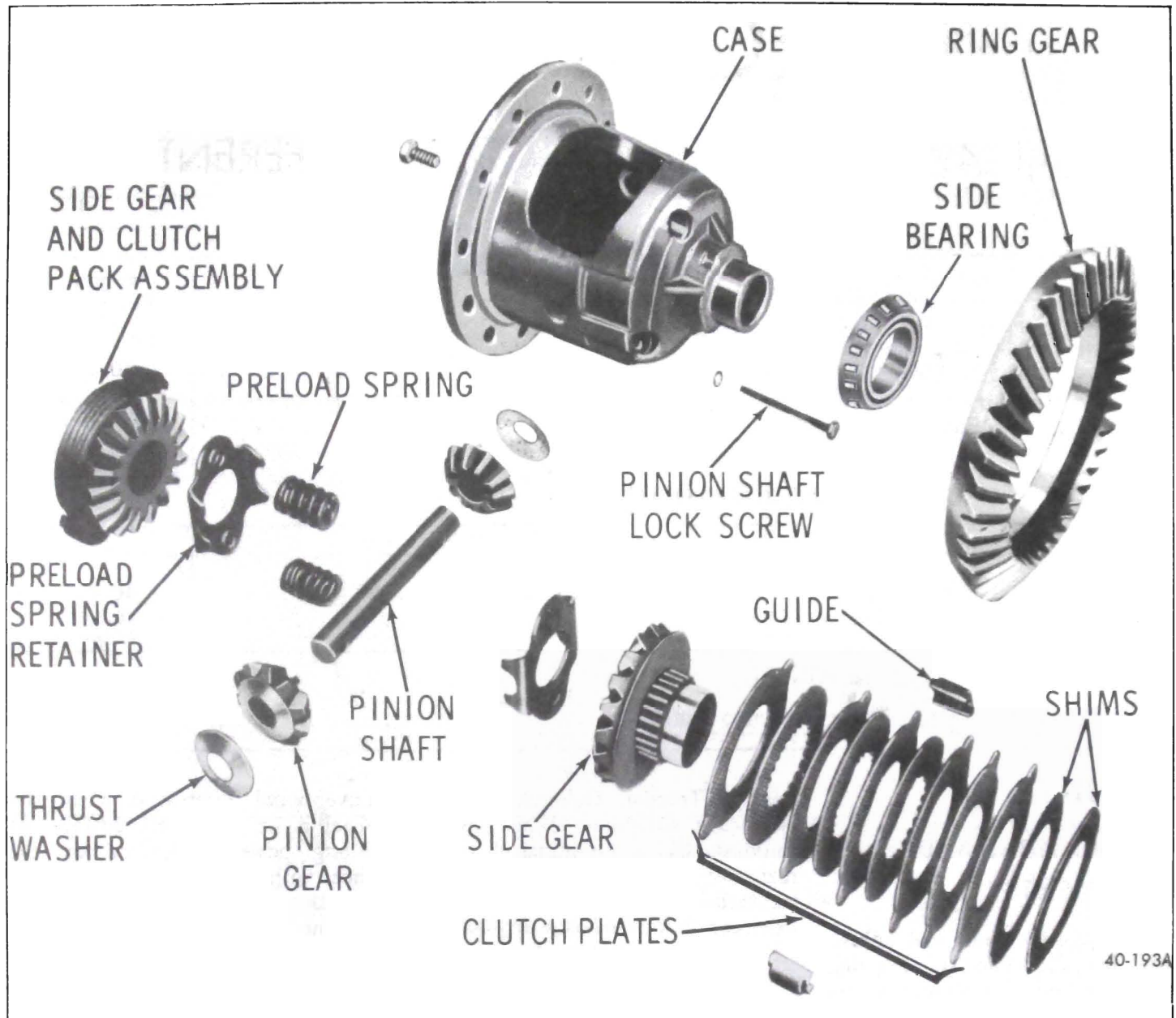

Figure 40-166 Positive Traction Differential - Exploded View

Another advantage of the Positive Traction Differential is that on uneven surfaces such as railroad tracks, chuck holes, etc., wheel action is not adversely affected. During power application on a conventional differential, when one wheel hits a bump and bounces clear of the road, it spins momentarily. When this rapidly spinning wheel again contacts the road, the sudden shock may cause the car to swerve. This action is also hard on tires and the entire drive train. With a Positive Traction Differential the free wheel rotates at the same speed as the wheel on the

road, thereby minimizing adverse effects.

40-43 OPERATION OF POSITIVE TRACTION DIFFERENTIAL

The Positive Traction Differential has pinion gears and side gears which operate in a manner similar to those in a conventional differential. The Positive Traction has clutch packs installed behind each side gear. These clutch packs are statically spring preloaded to provide an internal resistance to the differential action within the case itself. See

Figure 40-166. This preload assures an adequate amount of pull when extremely low tractive conditions such as wet ice, mud or snow are encountered at one rear wheel. It also provides smooth transfer of torque when traveling over alternating tractive to non-tractive conditions at either rear wheel.

During application of torque to the axle, the initial spring loading of the clutch packs is supplemented by the gear separating forces between the side and spider gears which progressively increases the resistance in the

differential. The unit therefore provides greater resistance under greater torque loads. This is not, however, a positive lock differential and it will release before excessive driving force can be applied to one rear wheel.

CAUTION: When working on a car with Positive Traction Differential, never raise one rear wheel and run the engine with the transmission in gear. The driving force to the wheel on the floor may cause the car to move.

DIVISION III

SERVICE PROCEDURES

40-44 POSITIVE TRACTION DIFFERENTIAL SERVICE PROCEDURES

All differential service procedures are the same in the Positive Traction differential as in a conventional differential, except for servicing the internal parts of the differential case assembly. All differential parts outside of the differential such as the ring gear, differential side bearings and axle shafts are the same in either differential assembly.

a. Disassembly of Differential

1. If ring gear or differential case is to be replaced, remove ring gear from case. Otherwise ring gear need not be removed.

2. If a differential side bearing is to be replaced, pull bearing from case using Remove Adapter J-2241-8 in center hole and Puller J-22588. See Figure 40-167.

3. Clamp case assembly in a brass jawed vise by ring gear or by case flange.

4. Remove pinion shaft lock screw and lock washer, then remove pinion shaft from case.

5. Remove the preload spring thrust blocks and spring from the case. See Figure 40-168.



Figure 40-167 Removing Differential Side Bearing

6. Rotate side gears until the pinions are in the open area of the case.

Remove the pinions and thrust washers.

7. Remove a side gear, clutch pack and shims from the case, noting location of the case to aid in reassembly. Remove the side gear clutch pack and shims from the opposite side.

8. Remove the clutch plate guides and separate the shims and clutch plates from the side gears.

NOTE: Keep the clutch plates in their original location in the clutch pack.

b. Cleaning and Inspection of Parts

1. Make certain that all differential parts are absolutely clean and dry.

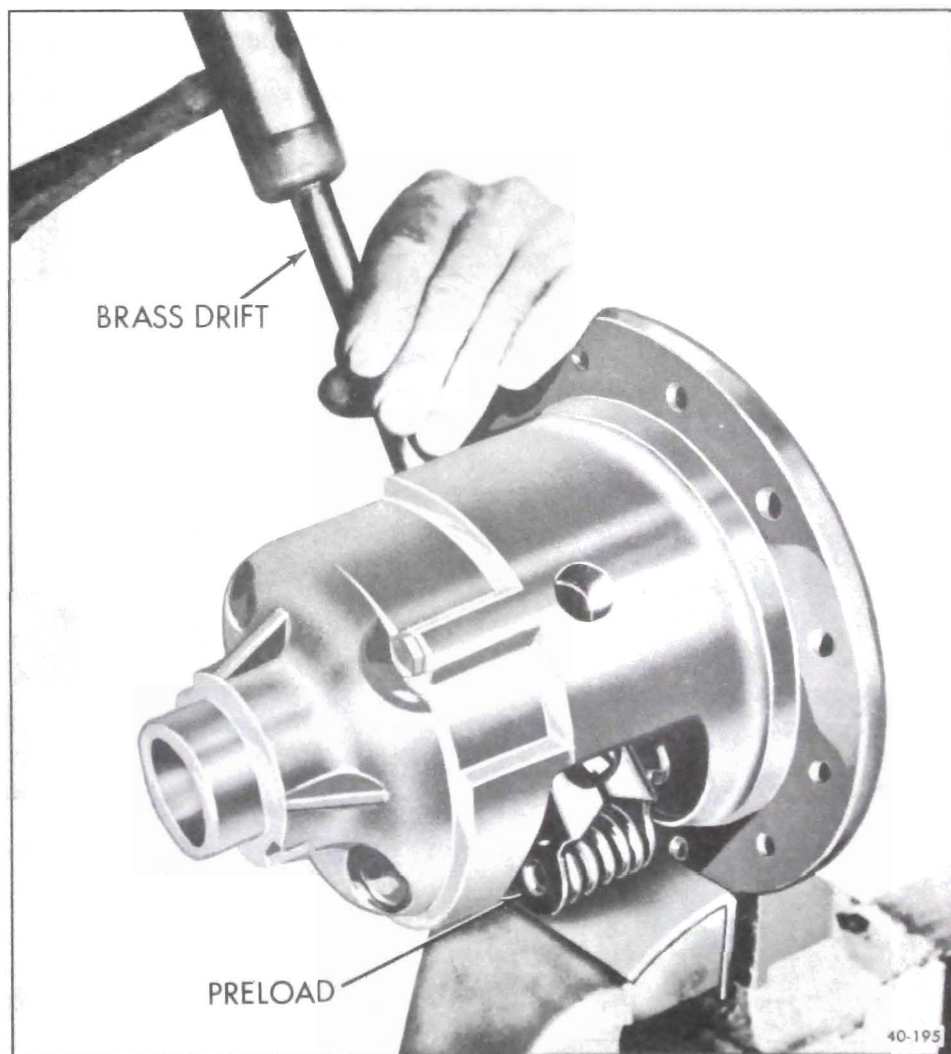

Figure 40-168 Removing Preload Thrust Blocks and Springs

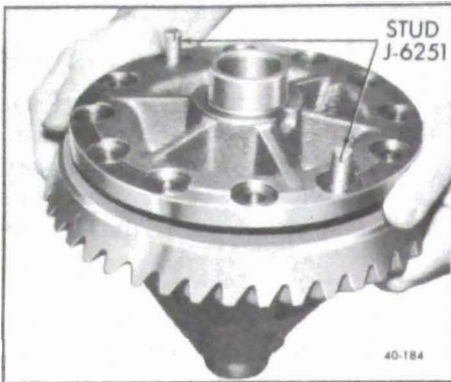

Figure 40-169 Installing Ring Gear on Differential Case

2. Inspect cross shaft, pinion and side gears. Replace any parts which are excessively scored, pitted or worn.

3. Inspect clutch discs and plates for worn, cracked or distorted condition. If any of these defects exist, new clutch packs must be installed.

c. Assembly of Differential

1. If ring gear was removed, install ring gear on case flange using studs as shown in Figure 40-169.

2. If differential side bearings were

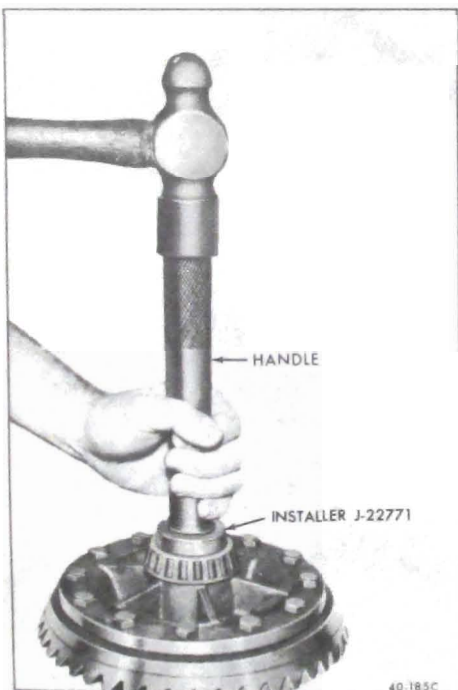

Figure 40-170 Installing Differential Side Bearings

removed, reinstall bearings using Installer J-22771 with Driver Handle J-8092. See Figure 40-170.

3. Apply Special Positive Traction Lubricant to the clutch plates.

4. Assemble the clutch packs as follows:

a. Alternately position seven clutch plates on the side gear, starting and ending with a clutch plate with the external lugs followed by two more external lug clutch plates.

b. Install the two clutch guides over the clutch plate lugs.

c. Install the same shims which were removed or an equal amount on the clutch plate.

d. Repeat Steps a, b, and c on the other clutch pack.

5. Check the pinion to side gear clearance as follows:

a. Install one side gear with clutch pack and shims in the case.

b. Position the two pinion gears and thrust washers on the side gear and install the pinion shaft.

c. Compress the clutch stack by inserting a screwdriver or wedge between the side gear and the pinion shaft.

d. Install dial indicator with the contact button against the pinion gear. See Figure 40-171.

e. Rotate pinion gear. Clearance should be .001" to .006".

f. If clearance is more than .006", add shims between clutch pack and case. If clearance is less than .001", remove shims. A .002" shim will change clearance approximately .001". Recheck clearance after adding or subtracting shims.

g. Remove side gear and repeat

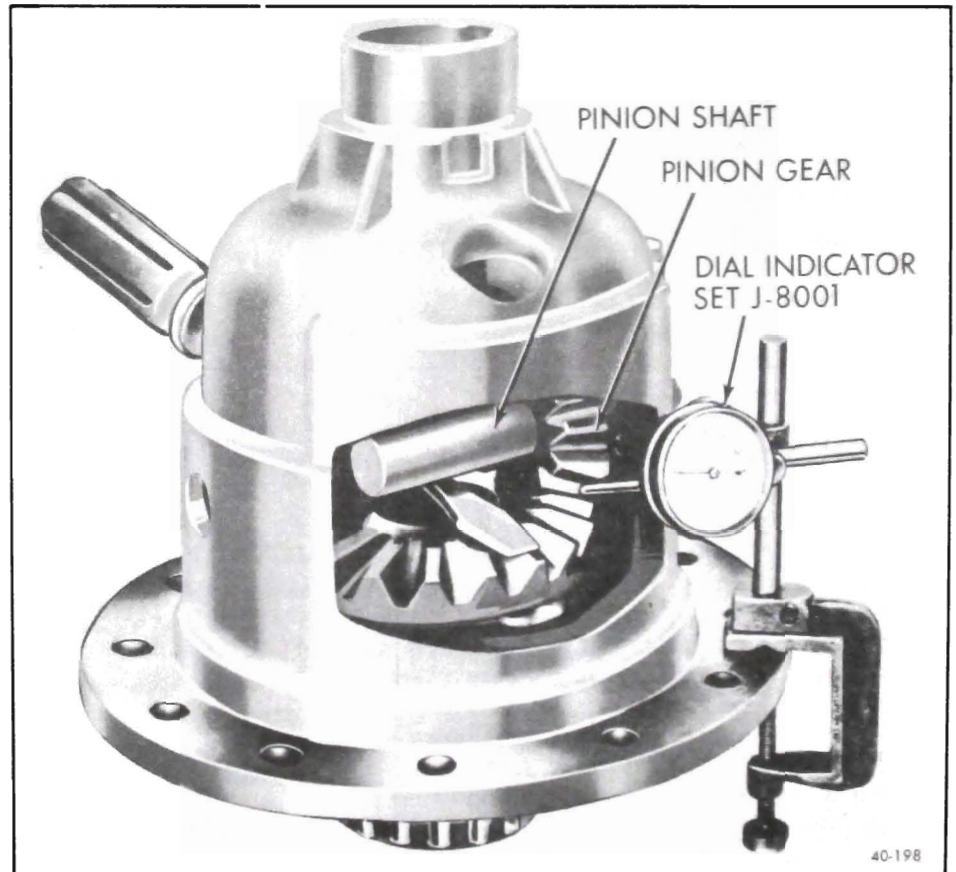

Figure 40-171 Checking Side Gear to Pinion Gear Backlash

procedure with opposite clutch pack, on opposite side of case.

6. Remove pinion gear shaft, pinions and thrust washers.

7. Install the remaining side gear and clutch pack with correct shims in the case.

8. Place the pinion gears on the side gears and rotate into correct position.

9. Compress the preload springs as shown in Figure 40-172 and install the preload thrust blocks and springs between the side gears.

10. Insert the thrust washers behind the pinion gears.

11. Install the pinion shaft and retain with the lock bolt. Tighten lock bolt 24 lb. ft.

12. Check the side gear splined hole to be certain it is in line with the hole in the preload thrust blocks. The spring retainer can be moved slightly to correct misalignment.

40-45 POSITIVE TRACTION FLUSHING PROCEDURE

The following procedure is established for flushing the Positive Traction Differential in the event the wrong lubricant is accidentally added.

1. Drain original lubricant from differential housing.

2. Fill axle with a light, non-detergent engine oil.

3. Raise both rear wheels off floor.

4. With car properly supported, run car in "Drive" range for three to four minutes. Do not exceed 30

MPH on speedometer or accelerate or decelerate rapidly.

5. Remove oil from axle.

6. Repeat Steps 2, 3, 4 and 5. It is important that the axle be flushed two times to insure complete removal of the foreign lubricant.

7. Fill differential housing with positive traction lubricant (SAE 90 gear lube meeting specification for GM Part No. 1050081).

DIVISION IV TROUBLE DIAGNOSIS

40-46 TESTING POSITIVE TRACTION DIFFERENTIAL

If there is a doubt that a Buick is

equipped with a Positive Traction Differential, or to determine if this option is performing satisfactorily, a simple test can be performed.

1. Place transmission in neutral.

2. Raise one rear wheel off floor and place a block of wood in front and rear of opposite wheel.

3. Remove wheel cover and install torque wrench with extension on lug nut.

3. Disregard breakaway torque and observe only torque required to continuously turn wheel smoothly. If differential assembly is equipped with Positive Traction, the rotating torque will be at least 30 lb.ft.

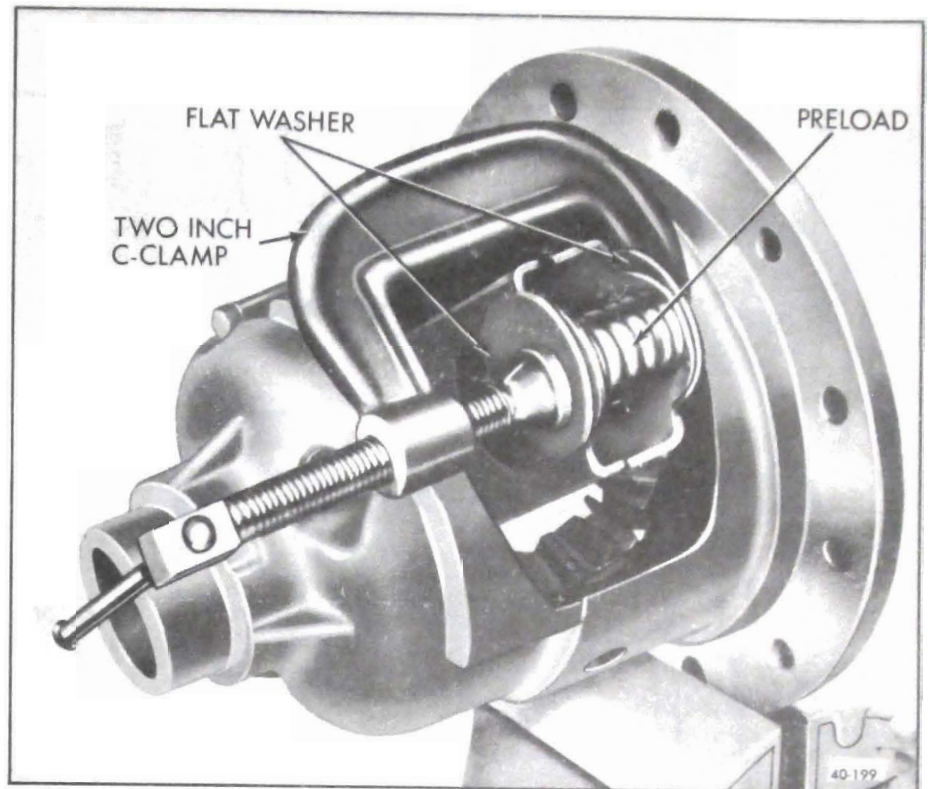
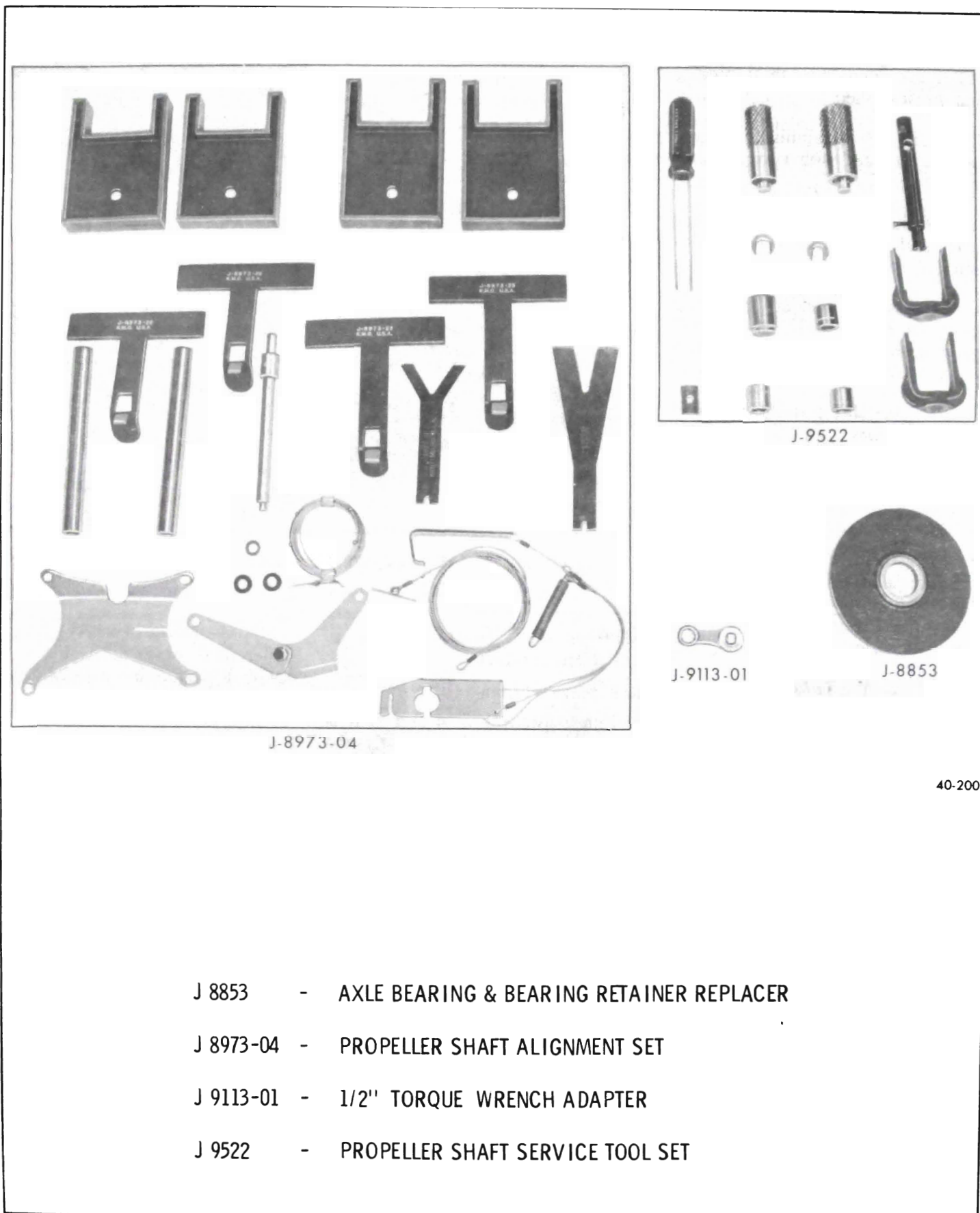
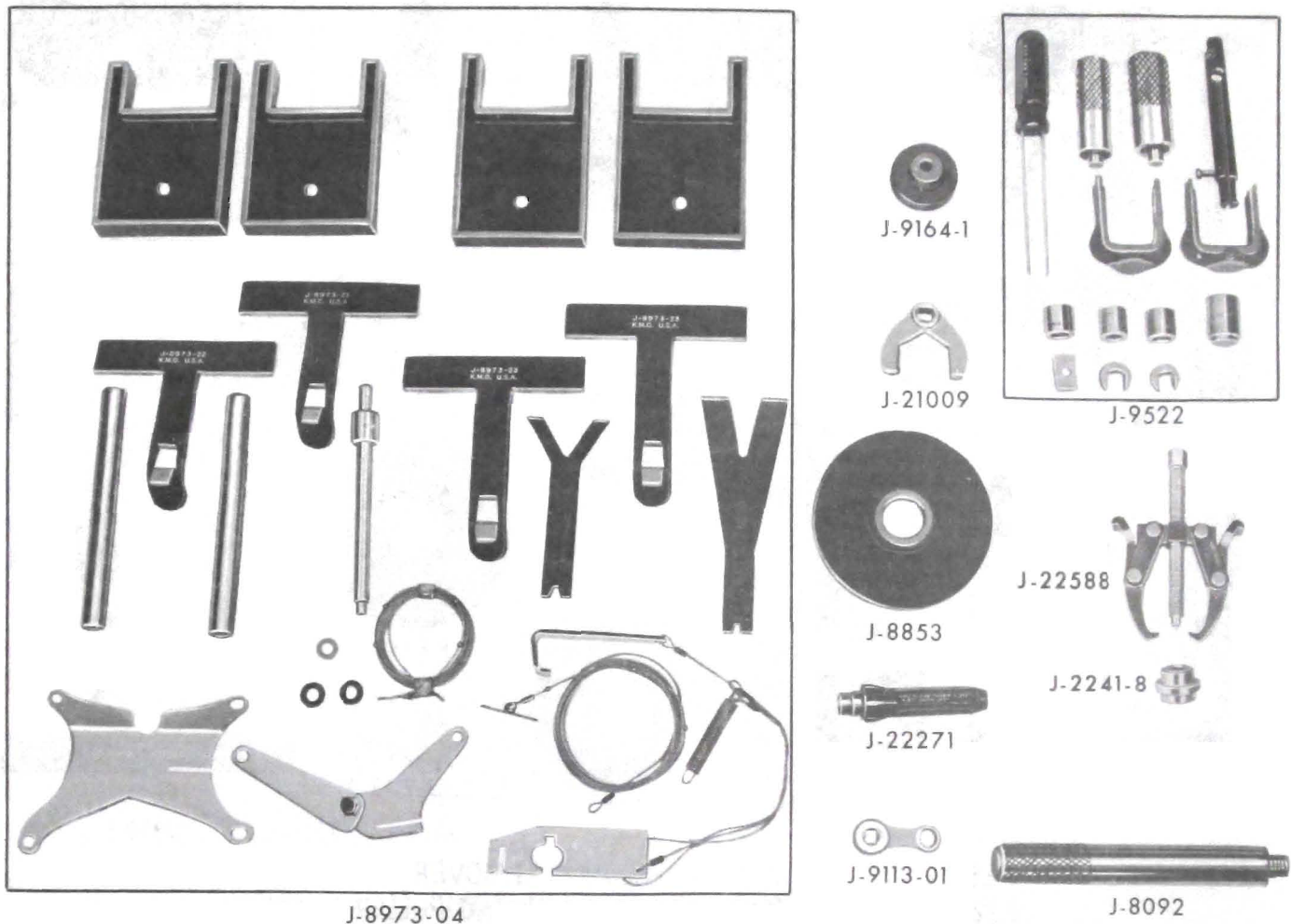

Figure 40-172 Compressing Preload Springs



- J 8853 - AXLE BEARING & BEARING RETAINER REPLACER
- J 8973-04 - PROPELLER SHAFT ALIGNMENT SET
- J 9113-01 - 1/2" TORQUE WRENCH ADAPTER
- J 9522 - PROPELLER SHAFT SERVICE TOOL SET

Figure 40-173 Special Tools - Propeller Shaft



- J 22588 - DIFFERENTIAL SIDE BEARING PULLER
 J 2241-8 - DIFFERENTIAL SIDE BEARING PLUG
 J 7013-24 - REAR BEARING RETAINER BEARING INSTALLER
 J 8092 - DRIVE HANDLE
 J 8853 - AXLE BEARING AND BEARING RETAINER REPLACER
 J 8973-04 - PROPELLER SHAFT ALIGNMENT SET
 J 9113-01 - 1/2" TORQUE WRENCH ADAPTER
 J 9522 - PROPELLER SHAFT SERVICE TOOL SET
 J 9164-1 - CENTER SUPPORT BEARING INSTALLER
 J 21009 - CENTER BEARING LOCK NUT WRENCH
 J 22271 - PROPELLER SHAFT CENTER BALL SEAL INSTALLER

40-2015

Figure 40-174 Special Tools
 Section D

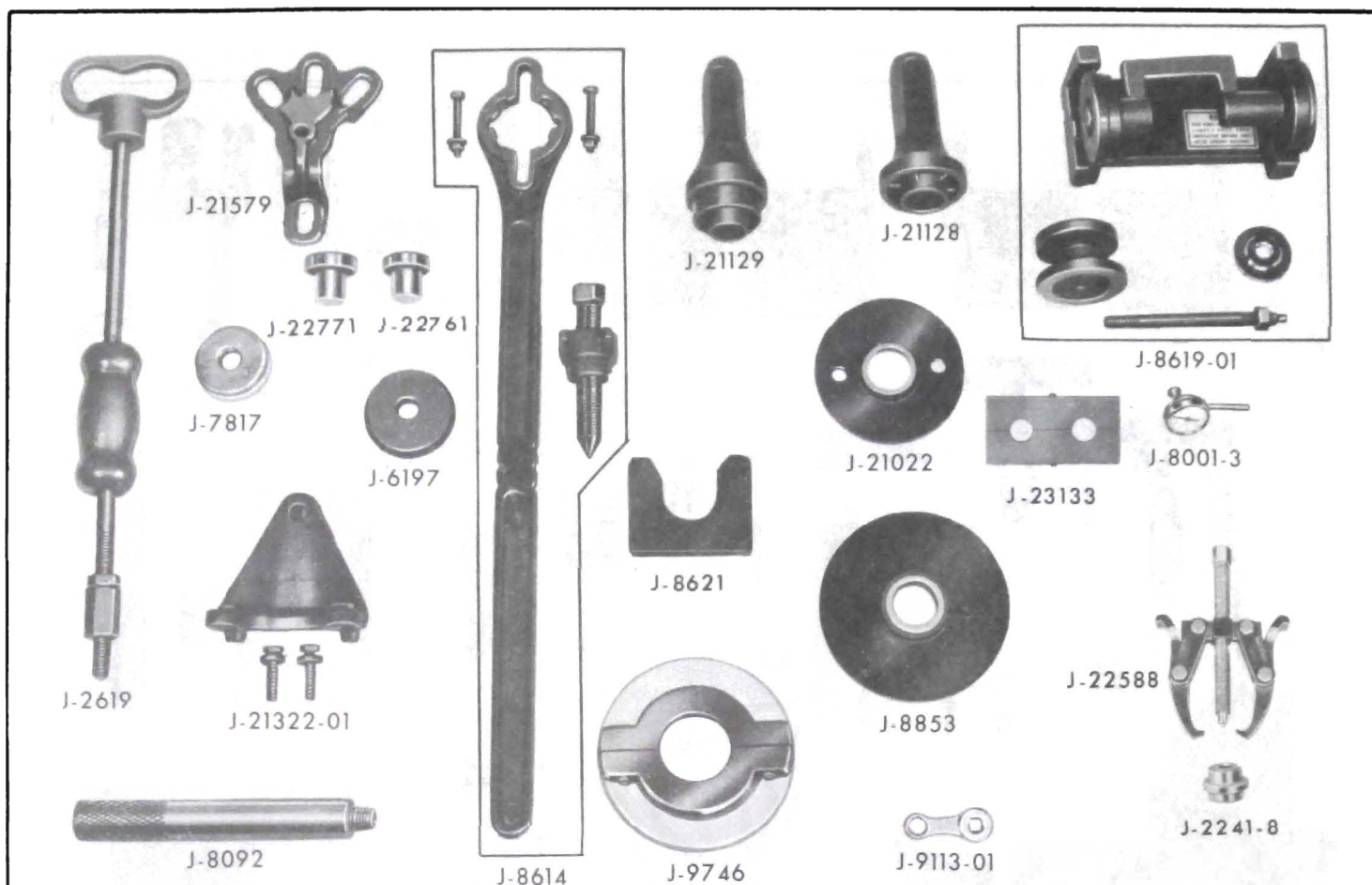

- J 8621 - AXLE SHAFT BEARING REMOVER
- J 22588 - DIFFERENTIAL SIDE BEARING PULLER
- J 2241-8 - DIFFERENTIAL SIDE BEARING PLUG
- J 2619 - SLIDE HAMMER ASSEMBLY
- J 9745 - REAR PINION BEARING OUTER RACE INSTALLER
- J 7817 - FRONT PINION BEARING OUTER RACE INSTALLER
- J 8001 - DIAL INDICATOR
- J 8092 - DRIVE HANDLE
- J 8614 - COMPANION FLANGE HOLDER AND REMOVER
- J 8619-01 - PINION SETTING GAUGE
- J 23133 - AXLE SHAFT BEARING REMOVER
- J 8853 - AXLE BEARING AND BEARING RETAINER REPLACER
- J 9113-01 - 1/2" TORQUE WRENCH ADAPTER
- J 22771 - DIFFERENTIAL SIDE BEARING INSTALLER
- J 22761 - DIFFERENTIAL SIDE BEARING INSTALLER
- J 21128 - PINION OIL SEAL INSTALLER
- J 21129 - AXLE SHAFT OIL SEAL INSTALLER
- J 21322-01 - RING GEAR AND CASE REMOVER
- J 9746 - REAR PINION BEARING REMOVER
- J 21579 - AXLE SHAFT REMOVER

40-2028

Figure 40-175 Special Tools -
Sections E and F

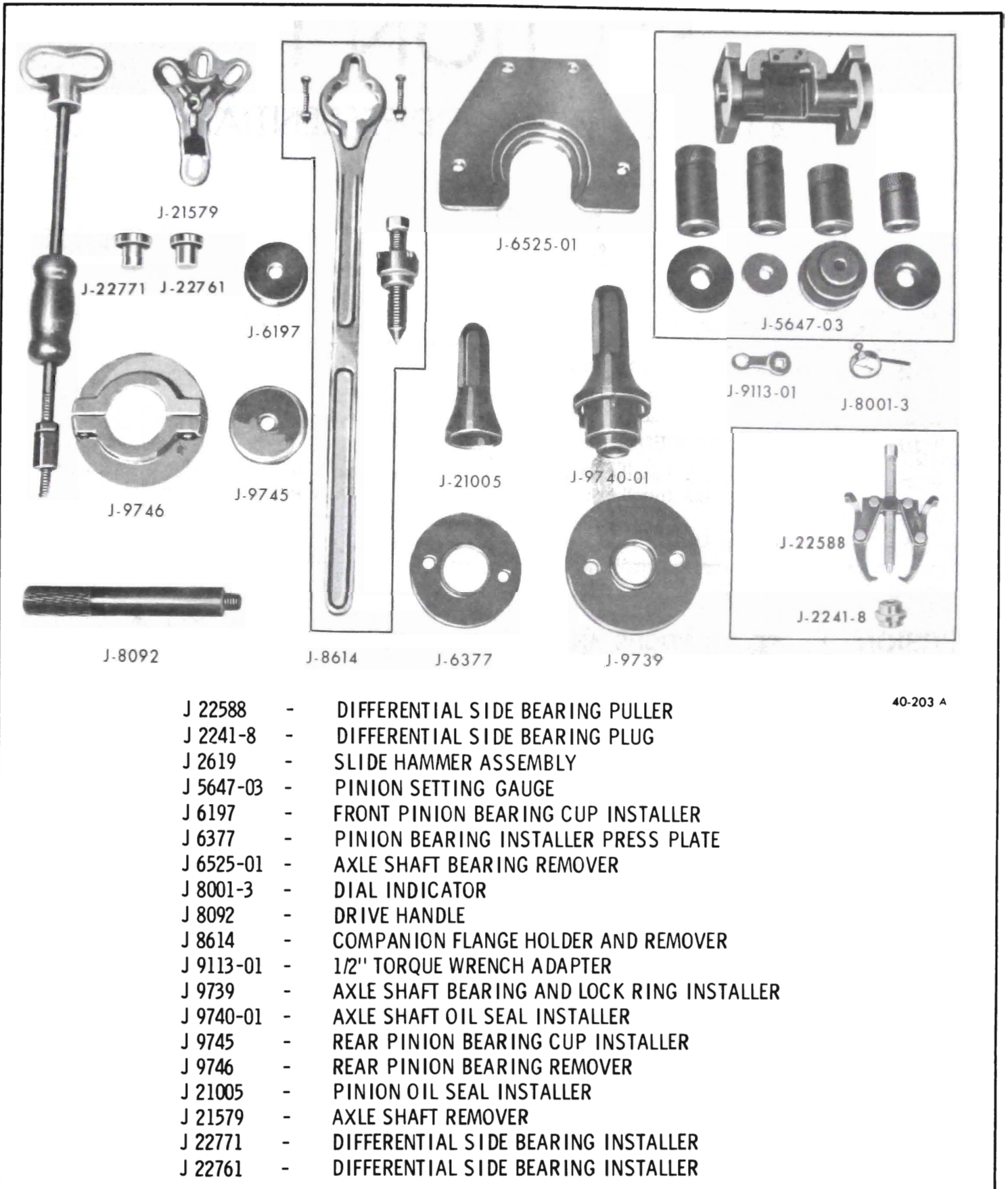

40-203 A

Figure 40-176 Special Tools -
Sections G and H