

# SECTION B

## AUTOMATIC LEVEL CONTROL

### CONTENTS

Division	Subject	Paragraph
I	SPECIFICATIONS AND ADJUSTMENTS:	
	Automatic Level Control Specifications.....	45-1
	Trim Adjustment — On Car.....	45-2
II	DESCRIPTION AND OPERATION:	
	Description and Operation of Automatic Level Control.....	45-3
III	SERVICE PROCEDURES:	
	Removal and Installation of Tubing.....	45-4
	Removal of Compressor, Reservoir and Regulator Valve Assembly.....	45-5
	Disassembly of Compressor Assembly.....	45-6
	Cleaning and Inspection of Parts.....	45-7
	Assembly of Compressor Assembly.....	45-8
	Installation of Compressor, Reservoir and Regulator Assembly.....	45-9
IV	TROUBLE DIAGNOSIS:	
	Quick Check of Automatic Level Control System.....	45-10
	Compressor Output Test — On Car.....	45-11
	Pressure Regulator Test.....	45-12
	Height Control Valve Test.....	45-13
	Leak Tests.....	45-14
	Trouble Diagnosis Chart.....	45-15

## DIVISION I SPECIFICATIONS AND ADJUSTMENTS

### 45-1 AUTOMATIC LEVEL CONTROL SPECIFICATIONS

#### a. Tightening Specifications

Use a reliable torque wrench to tighten the parts listed to insure proper tightness without straining or distorting parts. These specifications are for clean and lightly lubricated threads only; dry or dirty threads produce increased friction which prevents accurate measurement of tightness.

Part	Location	Thread Size	Torque Lbs. In.
Screw	Compressor Bracket to Skirt.....	1/4-14	96
Nut	Compressor to Bracket.....	#10-32	30
Bolt	Pressure Regulator Valve to Compressor.....	#10-32	30
Nut	Reservoir or Compressor Retaining Bolt.....	#10-32	30
Adapter	Rubber Mount to Compressor Retaining Bolt.....	#10-32	30
Screw	Height Control Valve Bracket to Frame.....	1/4-14	96
Screw	Height Control Valve Bracket to Valve.....	#8-32	18
Nut	Overtravel Body to Lever Adjusting.....	1/4-28 Locking	75
Screw	Vacuum Regulator Valve.....	1/4-14	96

#### b. General Specifications

Compressor, Pressure Regulator Valve and Tank Assembly.....Two-Stage, Vacuum Actuated  
 Shocks.....Delco Superlift Direct Double Acting  
 Spring.....Coil

## 45-2 TRIM ADJUSTMENT - ON CAR

Trim adjustment should be performed with a full fuel tank (or the equivalent in load at the rate of six pounds per gallon of gasoline added over center of fuel tank.)

### a. Preparation

1. Raise car using drive-on hoist.
2. Remove Superlift air supply line at height control valve. See Figure 40-8.
3. Connect male end of Fill Valve Assembly, J-21999, to Superlift air supply line.
4. Inflate Superlifts to 8-15 psi, use tire gage on fill valve to determine pressure. Jounce car to neutralize suspension.

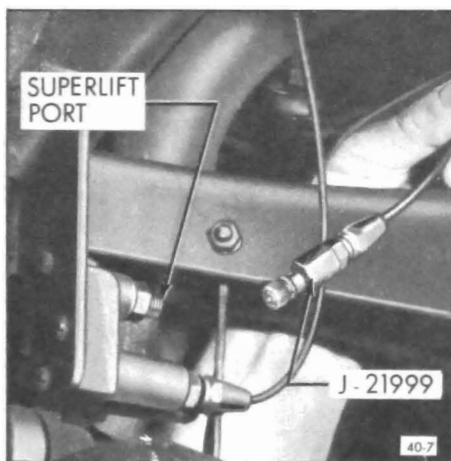

Figure 40-8 - Remove Superlift Air Supply Line

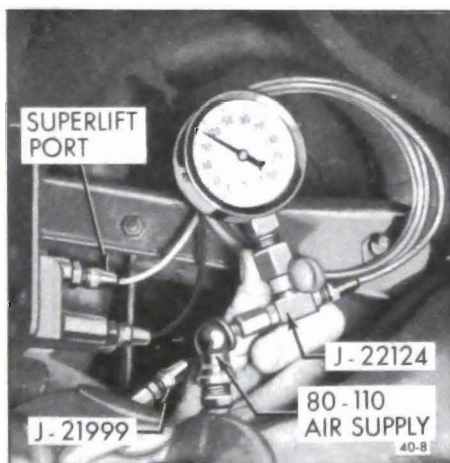

Figure 40-9 - Connect Test Gage to Superlift Outlet

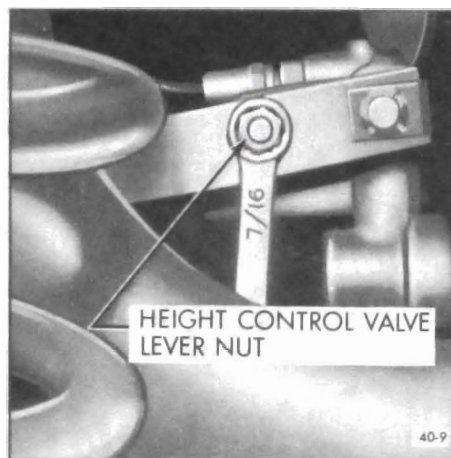

Figure 40-10 - Loosen Height Control Valve Lever Nut

5. Connect test gage J-22124 to Superlift outlet on height control valve and attach an 80-110 psi air pressure source to test gage. See Figure 40-9.

### b. Adjustment

1. Loosen height control valve lever adjusting nut. See Figure 40-10.
2. Hold overtravel body down in exhaust position until air escapes from exhaust port. See Figure 40-11.
3. Slowly move overtravel body toward neutral position and point of minimum air bleed thru exhaust port. Tighten nut to 75 lb.in. With nut tight, a slight continuous air bleed should be noticeable thru exhaust port.

### c. Restore System

1. Remove test gage and air pressure

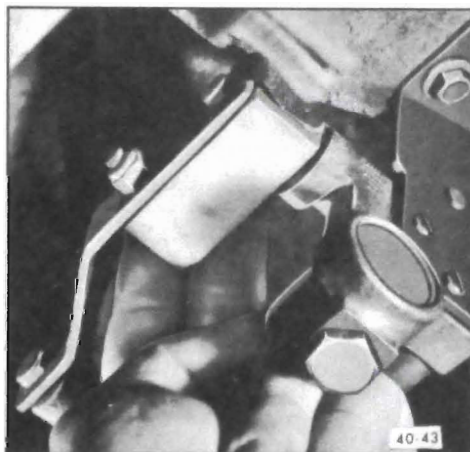

Figure 40-11 - Hold Overtravel Body in Exhaust Position

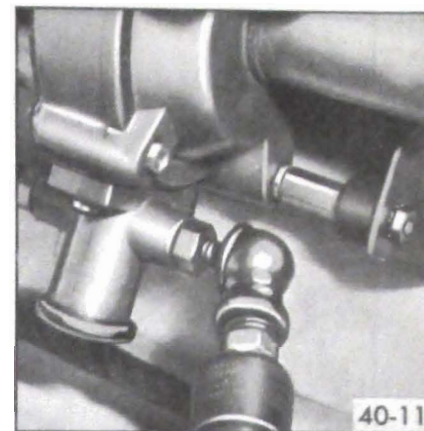

Figure 40-12 - Filling System Through Service Valve

source from Superlift outlet on height control valve.

2. Remove Fill Valve Assembly from Superlift air supply line and reconnect line to height control valve. Torque to 70 lb.in.

3. Lower car and inflate system through service valve on compression. See Figure 40-12. Load rear suspension and allow car to come to level position. Unload rear suspension, this will put the minimum 8 to 15 psi air pressure in the Superlifts.

## DIVISION II

## DESCRIPTION AND OPERATION

### 45-3 DESCRIPTION AND OPERATION OF AUTOMATIC LEVEL CONTROL SYSTEM

The Automatic Level Control System is available on Sportwagons, LeSabre, Wildcat, Electra and Riviera as a factory or dealer installed option. Its function is to maintain automatically the rear standing height of the car, even with load changes of up to 500 pounds placed directly over the rear axle. The system consists of a vacuum regulator valve, a vacuum operated air compressor, reservoir tank and pressure regulator assembly, height control valve, link, two Superlift rear shock absorbers and flexible air lines. See Figures 40-14, 15 and 16.



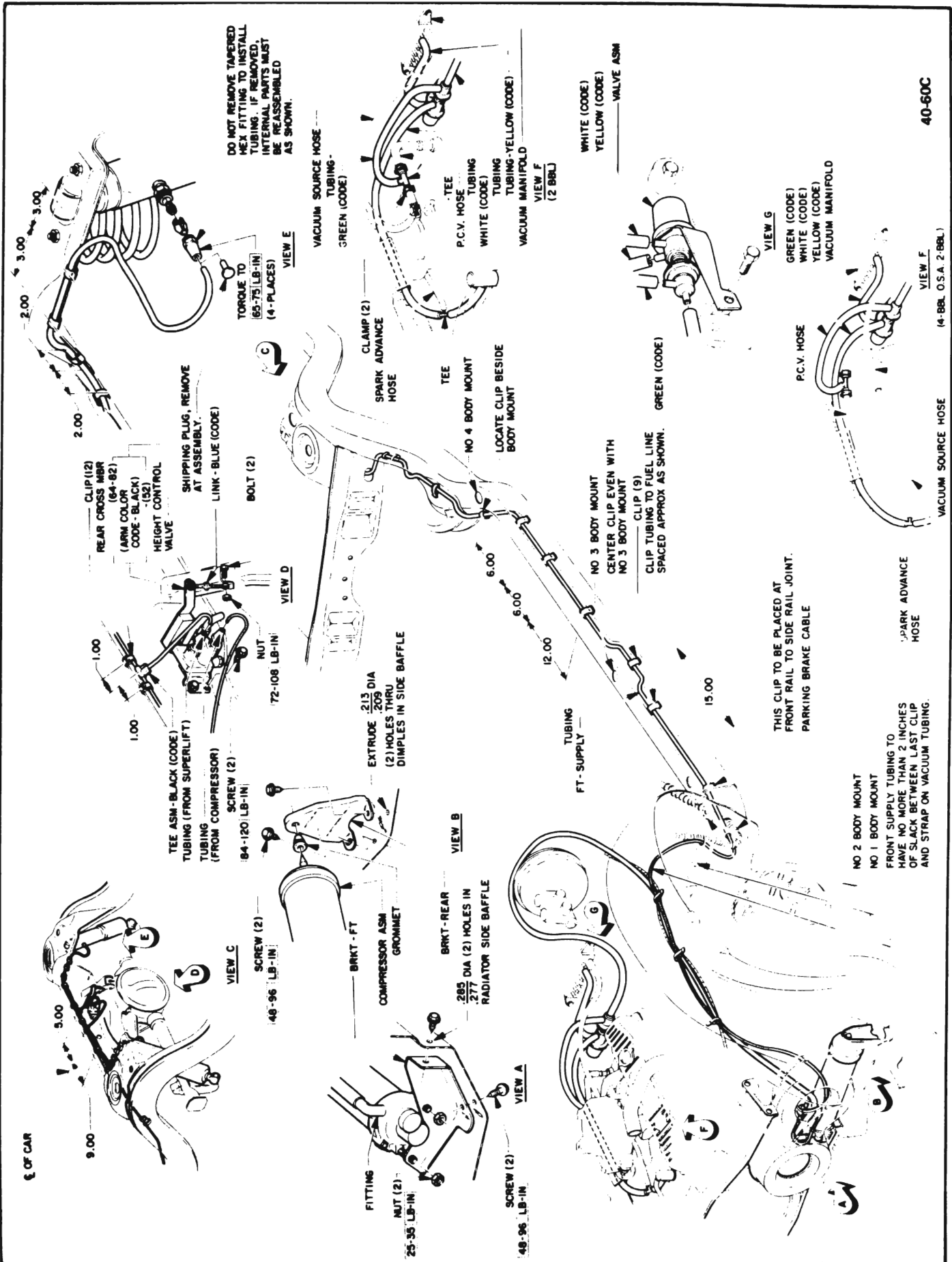

Figure 40-15 - 45-46-48000 Automatic Level Control Details





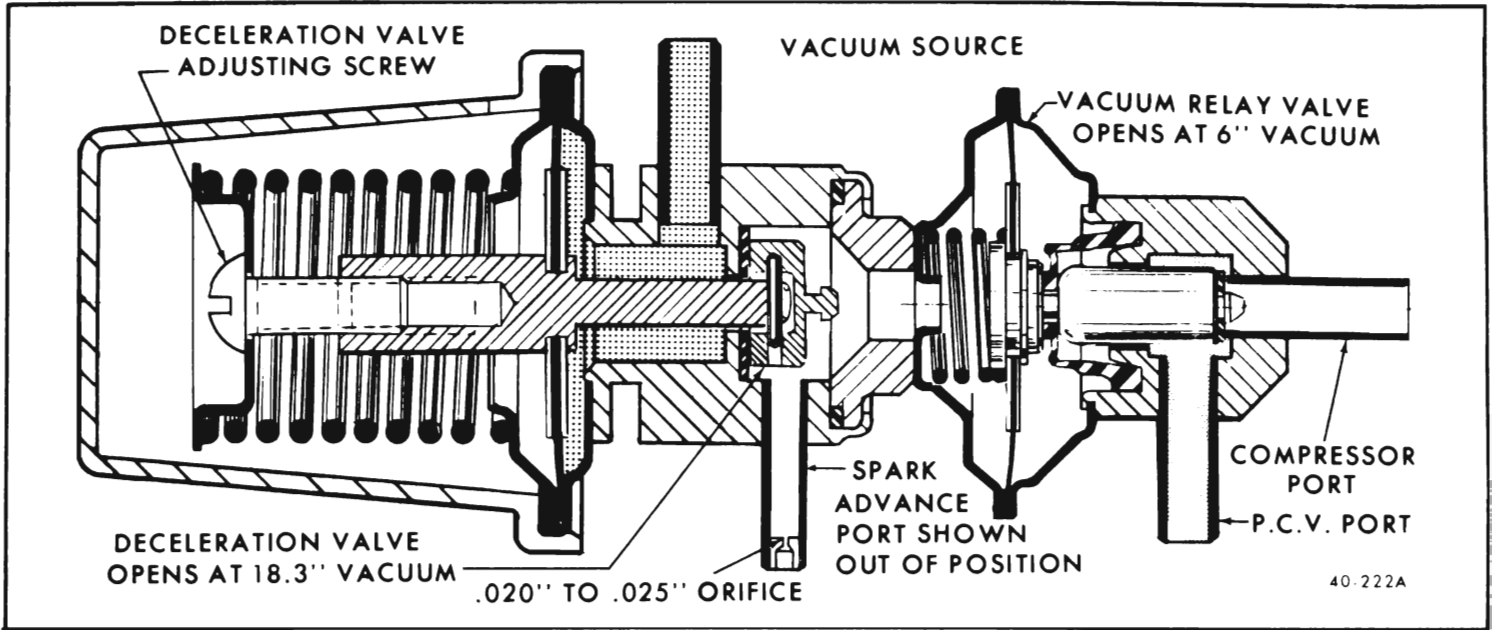

Figure 40-17 - Slow Idle Condition - Both the Deceleration Valve and the Vacuum Relay Valve are CLOSED

a. The vacuum regulator valve assembly consists of a relay valve which is pre-set to open at 6" of vacuum and a deceleration valve that is set to open at 18.3" of vacuum. The deceleration valve controls the relay during periods of deceleration. The relay valve is connected to the compressor and to the positive crankcase ventilator line by

rubber hose. The spark advance port of the regulator valve assembly is connected into the vacuum hose of the distributor vacuum advance and the intake manifold port is tapped into the rear of the intake manifold by rubber hose.

When the engine is operating at slow idle speed, the compressor will

not operate due to insufficient vacuum available to open the vacuum relay valve. See Figure 40-17. As engine RPM is increased to fast idle or to cruising speed, the increased engine vacuum is metered through a .020" to .025" restriction (orifice) located in the spark advance port of the vacuum regulator valve. See Figure 40-18.

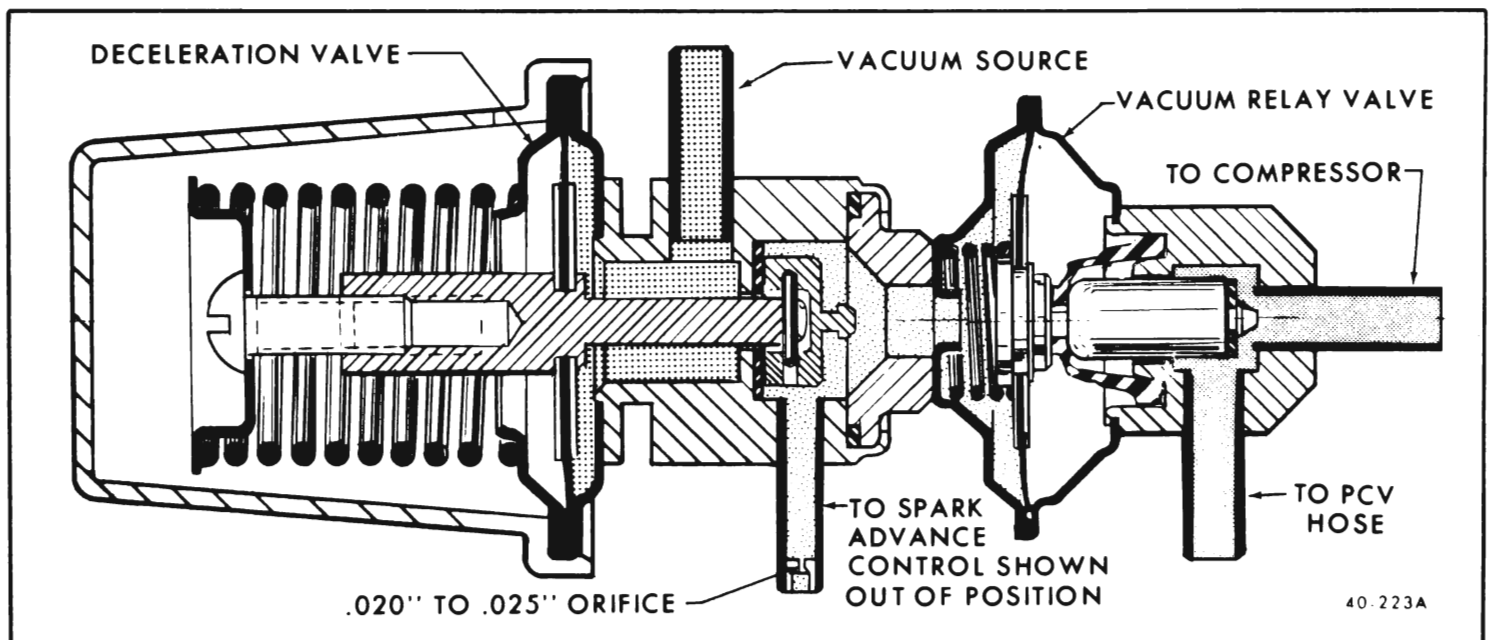

Figure 40-18 - Fast Idle Condition - Vacuum Relay Valve is OPEN

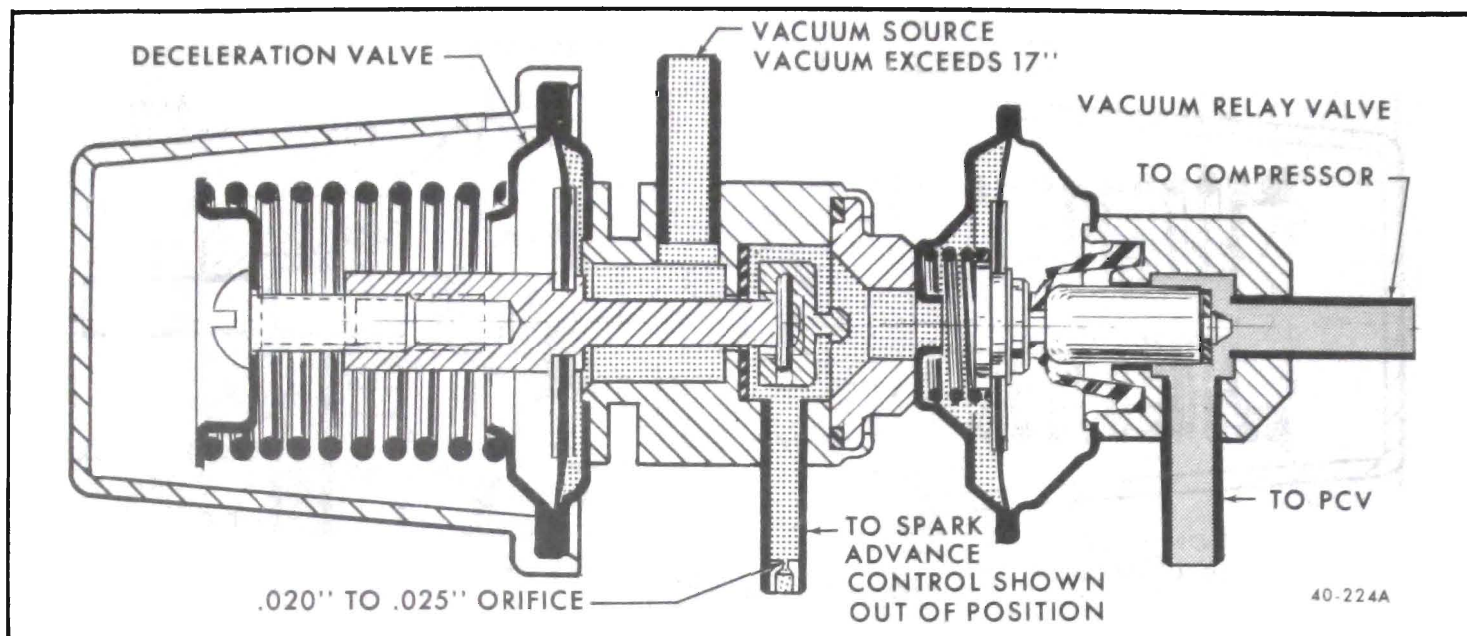

Figure 40-19 - Deceleration Condition - Both the Deceleration Valve and the Vacuum Relay Valve are OPEN

This increased vacuum overcomes the relay valve spring tension causing the relay valve to open and allows the compressor to operate on vacuum from the positive crankcase ventilation system.

To help maintain compressor output, it is necessary to provide vacuum to the compressor during deceleration conditions. This is accomplished through the connection of the deceleration valve vacuum port to the vacuum source. See Figure 40-19.

During deceleration, vacuum at the rear of the intake manifold exceeds 17" and vacuum at the spark advance port is negligible. The manifold vacuum overcomes the deceleration valve spring tension and causes the deceleration valve to open permitting vacuum to overcome the relay valve spring tension and open the relay valve to admit P.C.V. vacuum which in turn operates the compressor. Since there is literally no vacuum to the spark advance port, the .020" to .025" restriction (orifice) in the spark port prevents vacuum feed back from advancing the spark in the ignition distributor.

b. The compressor is a two-stage,

vacuum actuated type, requiring no lubrication. See Figure 40-20. High pressure air is supplied to the reservoir tank by the second stage of the two-stage compressor. The first stage intake stroke draws air at atmospheric pressure through a one way check valve located in the end of the first stage housing under the first stage housing cover. See Figure 40-22. On the first stage compression stroke, the intake valve is closed and

the oneway check valve in the second stage end of the piston is opened. This allows the air from the first stage cylinder to flow through the hollow piston into the second stage cylinder for high pressure compression. See Figure 40-23. The second stage compression stroke closes the check valve in the piston and opens the check valve in the end of the second stage housing. See Figure 40-24.

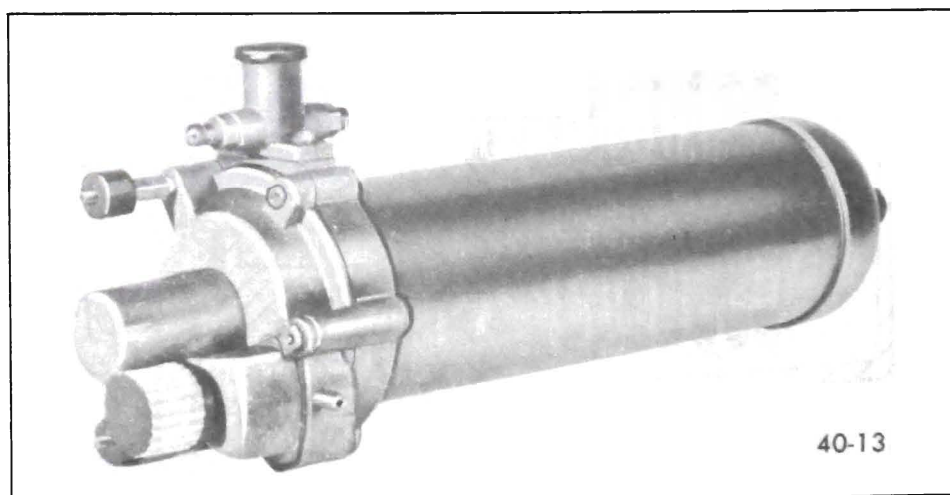

Figure 40-20 - Compressor, Reservoir Tank and Regulator Valve Assembly

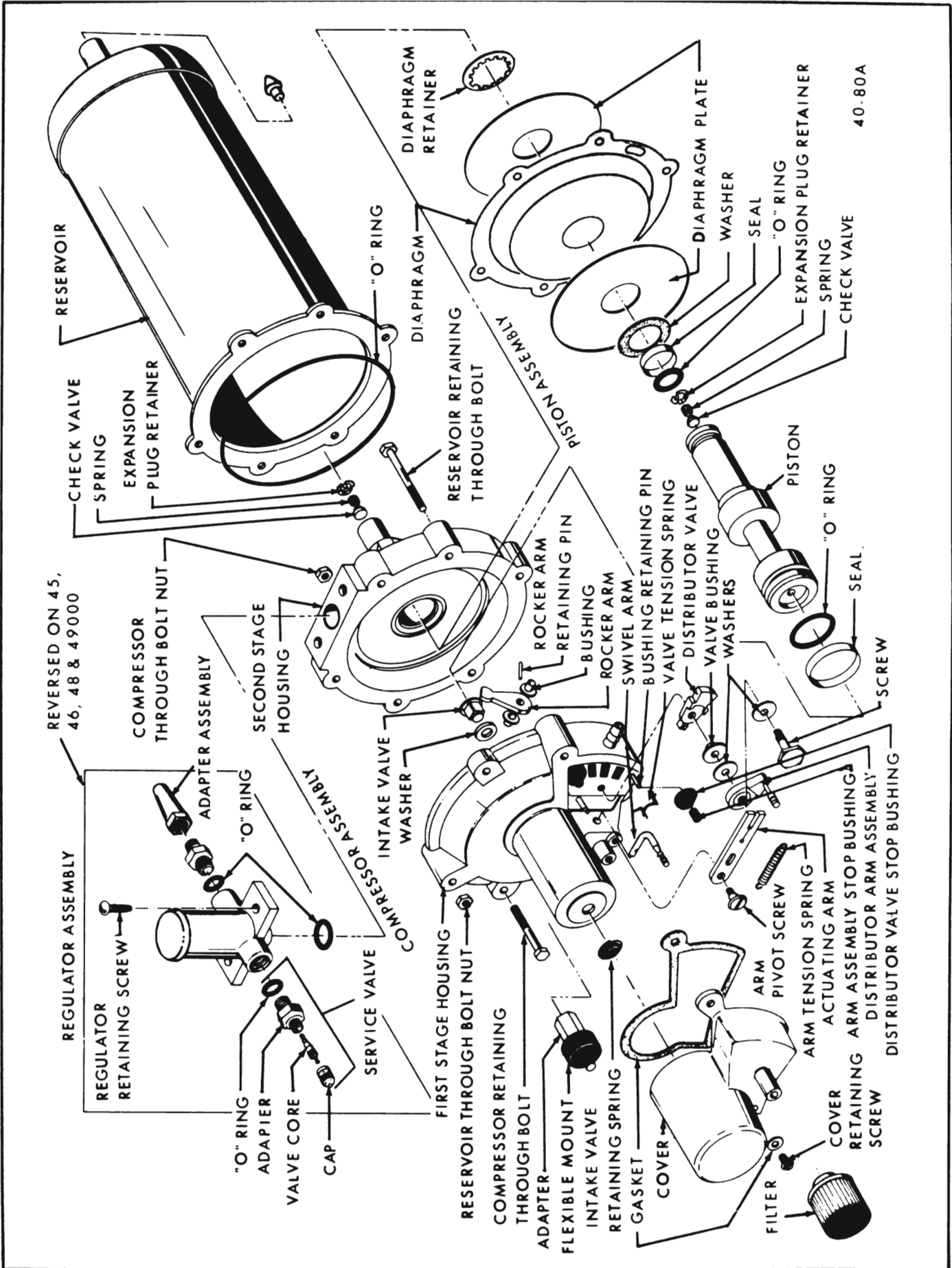

Figure 40-21 - Compressor, Reservoir Tank and Regulator Valve Assembly - Exploded View



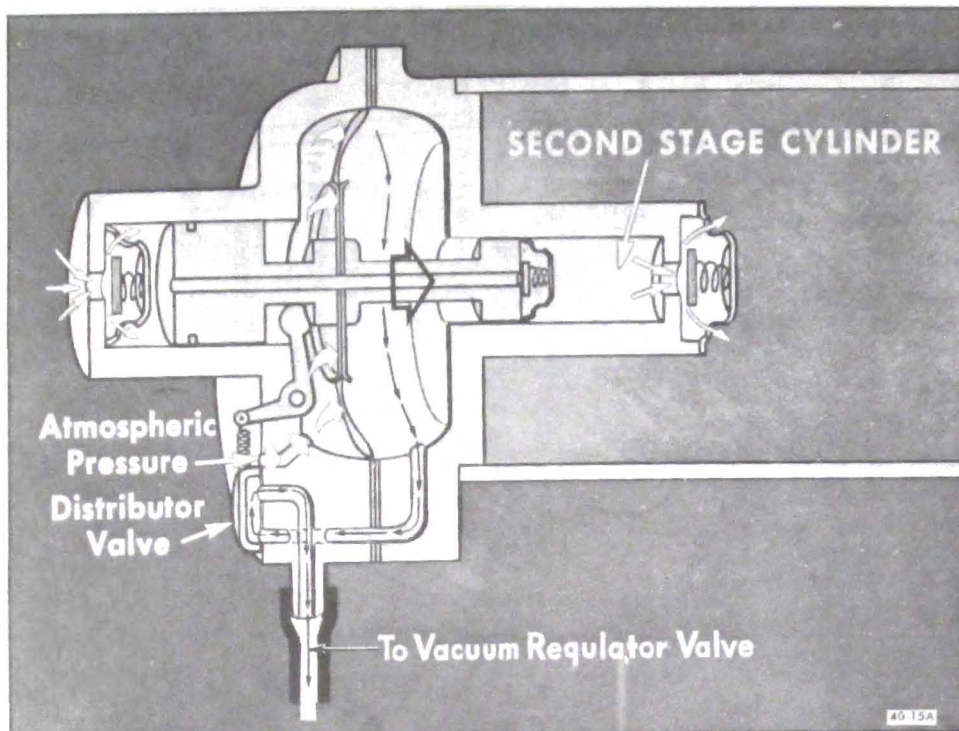

Figure 40-22 - First Stage Intake Stroke

The intake and compression strokes are controlled by a sliding distributor valve that is actuated through an arm that is tripped by the piston as it nears the end of each stroke. Each time the arm actuates the distributor valve, a different set of holes are covered in the first stage housing. The distributor valve controls the flow of intake manifold vacuum and air under atmospheric pressure, alternately to opposite sides of the compressor diaphragm. See Figures 40-23 and 24.

As the compressor cycles, the reservoir air pressure gradually increases causing a back pressure on the second stage piston until it equals the push of pressure against the diaphragm. At this point, a balanced condition is reached and the unit stops operating. After reservoir pressure drops due to system air usage, the compressor again begins to cycle and replenish the reservoir.

Pressure balance will depend upon the prevailing manifold vacuum and atmospheric pressure. Both are affected by altitude above or below sea level. Balance pressure will vary from approximately 150 to 275 psi.

c. The pressure regulator valve is preset and limits the reservoir outlet pressure to approximately 125 psi to avoid damage to the height control

valve and Superlift shocks. See Figure 40-25.

d. The height control valve, which is mounted on the frame, senses rear car height through a link attached to the rear upper control arm. When load is added to the car, the overtravel lever is forced up causing an internal lever to open the intake valve. See Figure 40-26. When this valve is open, high pressure air is admitted to the Superlift shocks. As the car raises to level (depending upon position of load), the intake valve shuts off.

When load is removed from the car, the overtravel lever is forced down causing the internal arm to open the exhaust valve. As the car lowers to the level position (depending upon position of load), the exhaust valve shuts off. See Figure 40-27.

A four to twenty-two second (at 70°F.) time delay mechanism, which is built into the height control valve, prevents air transfer due to normal ride movements. The overtravel lever, which pivots around the control valve shaft, rides off the flat side

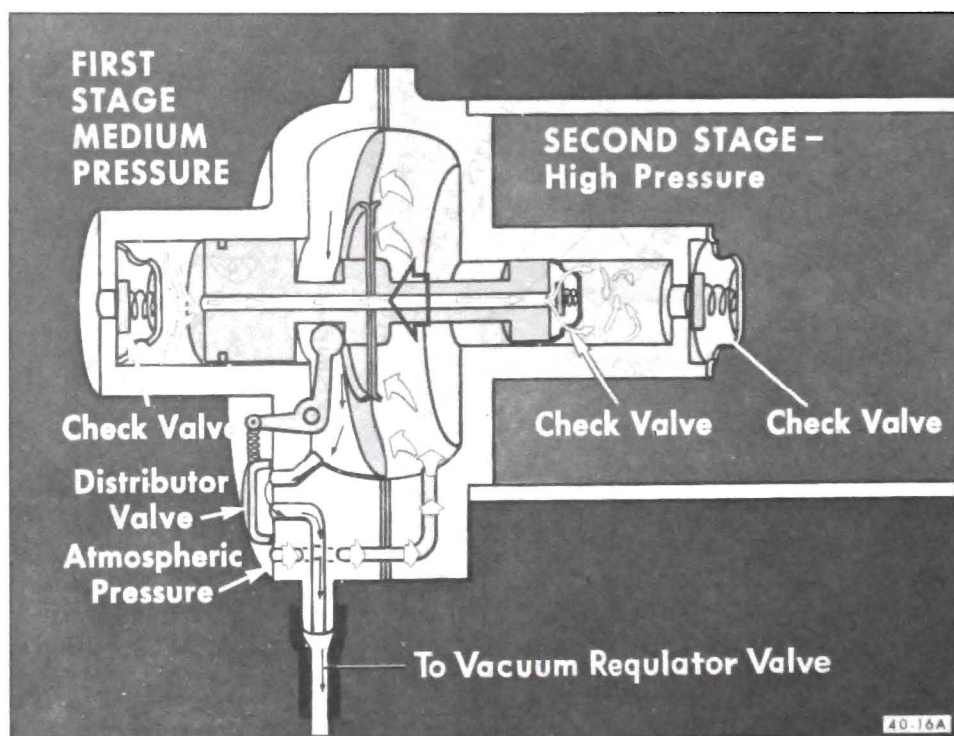

Figure 40-23 - First Stage Compression Stroke

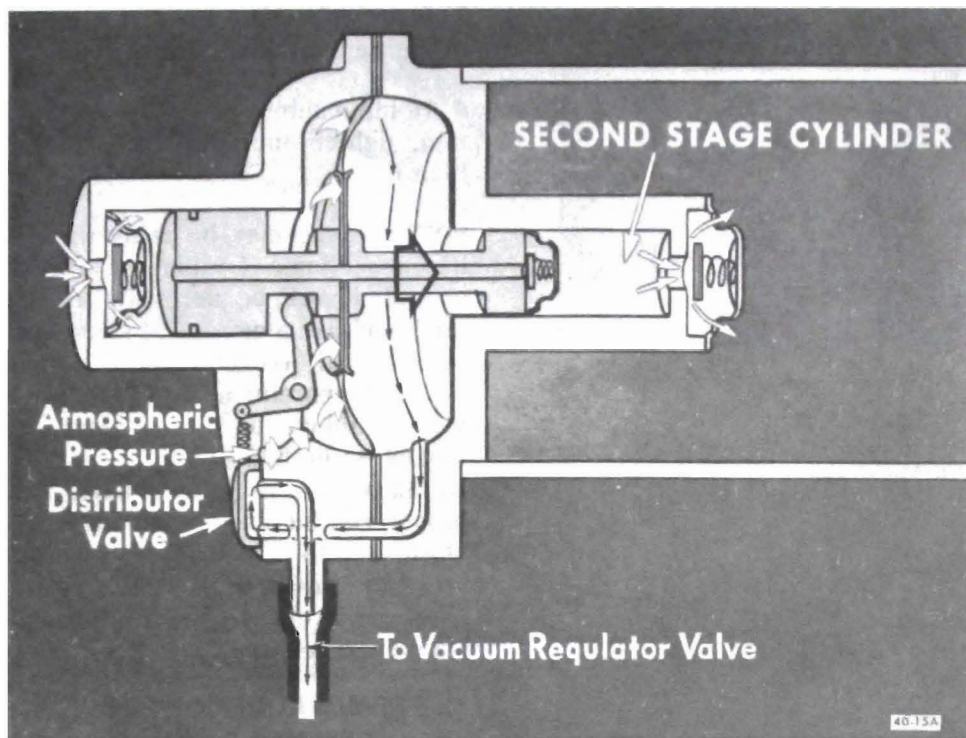

Figure 40-24 - Second Stage  
Compression Stroke

of the control valve shaft and does not have time to react to the rapid changes or normal ride motions. See Figure 40-28.

During changes due to loading, the time delay mechanism will allow the control valve shaft to open either the intake or exhaust valve as required, since this is not a rapid movement. See Figure 40-29.

e. The Superlift shock absorber is essentially a conventional hydraulic unit with a pliable nylon reinforced neoprene boot acting as an air chamber. See Figure 40-30.

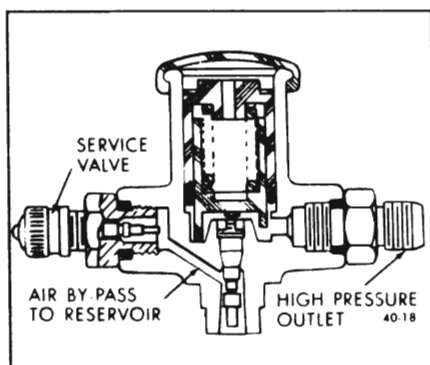

Figure 40-25 - Pressure Regulator  
Valve

An eight to fifteen psi air pressure is maintained in the Superlift at all times to minimize boot friction. This is accomplished by a check valve in

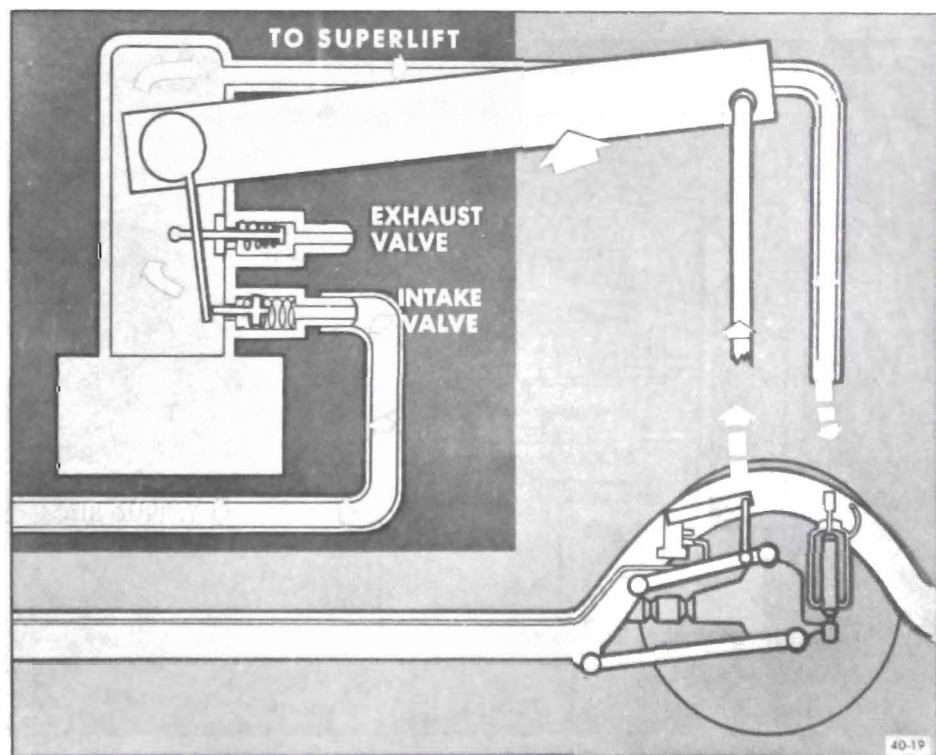

Figure 40-26 - Load Added to Car

the exhaust fitting on the control valve. Neither shock absorber function nor conventional ride motions thru rear coil springs is impaired in the event of accidental air pressure loss.

f. Flexible air lines are used throughout the system. The line is 1/8" diameter tubing. Each fitting consists of a rubber seal, metal sleeve and nut. See Figure 40-31. These parts are intended specifically for the 1/8" diameter line and must be used to effect a reliable seal.

### DIVISION III

#### SERVICE PROCEDURES

##### 45-4 REMOVAL AND INSTALLATION OF TUBING

**NOTE:** While the lines are flexible for easy routing and handling, care should be taken not to kink them and to keep them from coming in contact with the exhaust system.

Tubing may be removed by simply unscrewing a fitting nut. Be sure



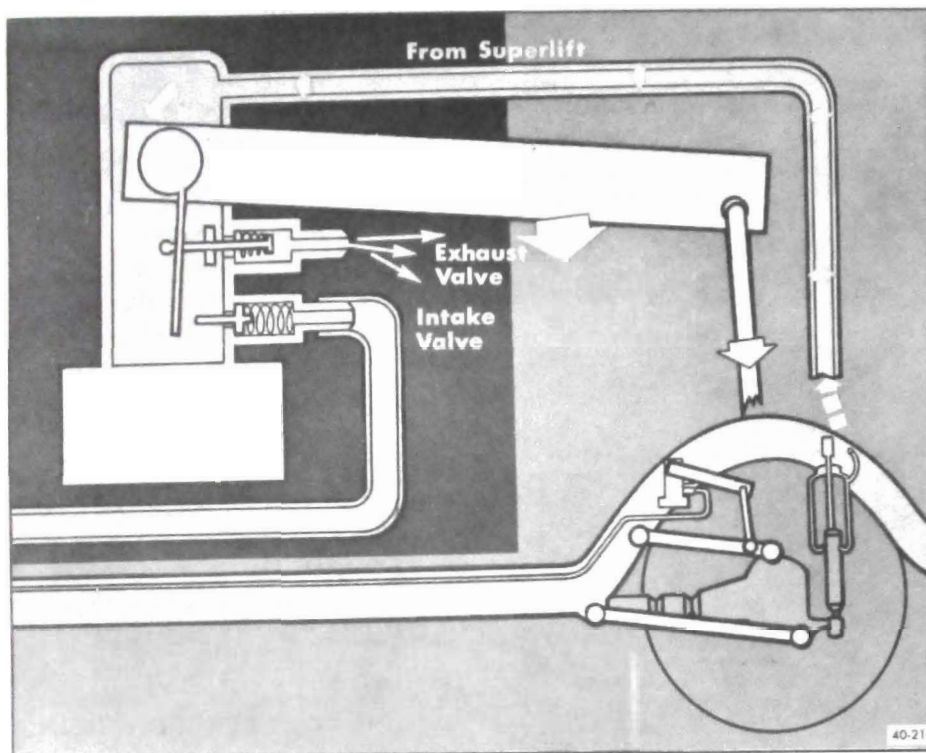

Figure 40-27 - Load Removed From Car

system is deflated thru service valve before separating air lines. When installing tubing at any Automatic Level Control fitting, be careful not to kink line.

1. Preassemble metal sleeve and rubber seal. See Figure 40-31.
2. Place nut on tubing.

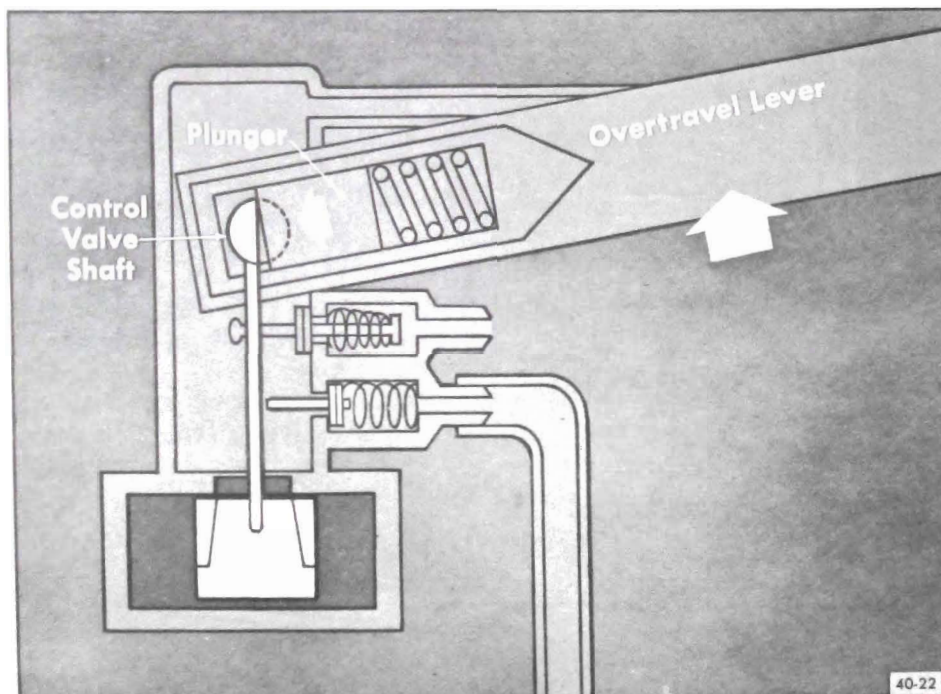

Figure 40-28 - Rapid Movement of Overtravel Lever

3. Insert tube into metal sleeve and rubber seal until tube bottoms.

4. Holding tubing in bottomed position, tighten tube nut securely (70 lb.in.)

**NOTE:** Tubing may be reinstalled at its connections. If tubing is cracked at end, it will be necessary to cut flush and use a new metal sleeve and rubber seal assembly as described above. Be careful not to remove too much tubing, or tubing may be kinked or broken at full suspension travel. Care should be taken that proper routing is followed in areas close to the exhaust system to prevent burning the tubing. Note particularly the areas at rear suspension cross member.

#### 45-5 REMOVAL OF COMPRESSOR, RESERVOIR AND REGULATOR VALVE ASSEMBLY

1. Deflate system through service valve.
2. Disconnect high pressure line at pressure regulator valve. Also disconnect vacuum line at compressor.

3. Remove nuts securing the assembly to the brackets and remove assembly.

#### 45-6 DISASSEMBLY OF COMPRESSOR ASSEMBLY

##### a. Disassembly of Compressor into Major Components

The compressor is a precision built mechanism that should be carefully handled and assembled. Care must be taken to prevent entrance of dirt or other foreign matter. This unit must not be lubricated as it is designed to operate dry.

1. Remove compressor as outlined in paragraph 45-5.
2. Remove two adapters and flexible mounts on compressor end of assembly.
3. Remove nuts from three reservoir

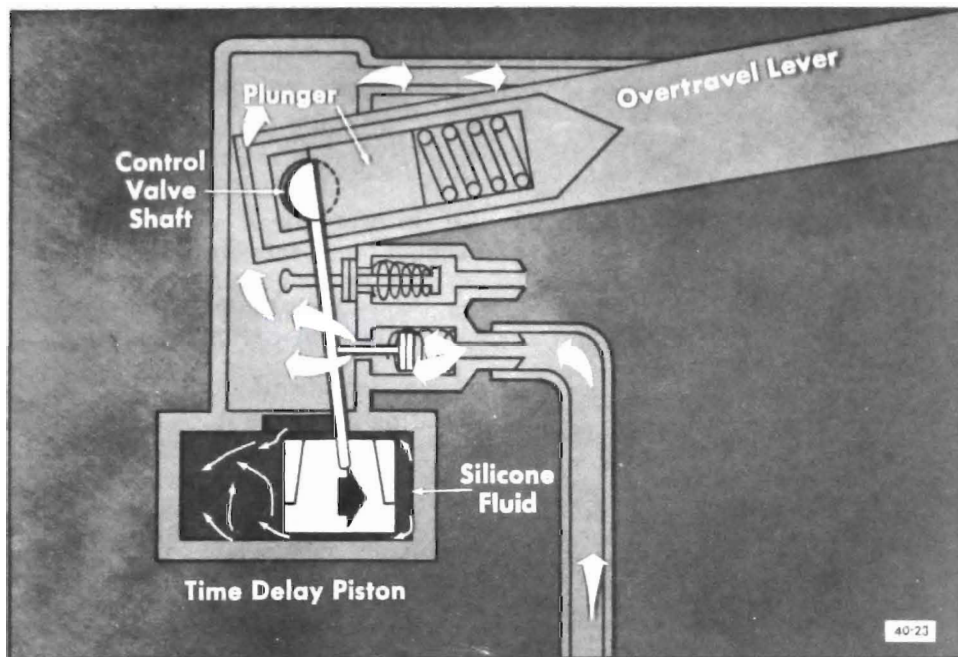

Figure 40-29 - Load Movement of Overtravel Lever

retaining (long) bolts. The bolts enter from reservoir flange side of unit.

4. Remove nuts from three compressor retaining (short) bolts. These bolts enter from compressor side of unit.

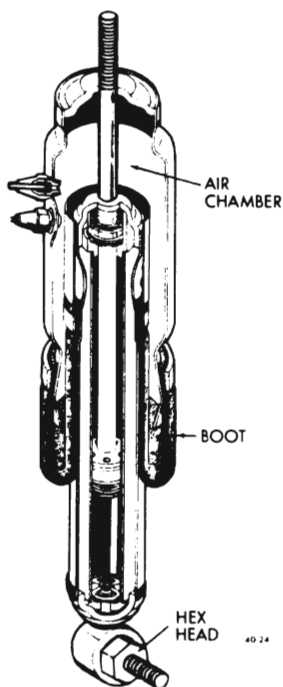

Figure 40-30 - Superlift Shock Absorber - Sectional View

**NOTE: DO NOT attempt to turn short bolts as they have a second nut hidden between reservoir flange and second stage housing. Always remove nuts from bolts while holding bolts stationary.**

5. Separate compressor assembly and reservoir. Discard reservoir sealing "O" ring.

6. Remove cover retaining screw. Remove cover and discard cover gasket.

7. Remove three compressor retaining (short) bolts that hold first and second stage housings together.

8. Separate first and second stage housings by sliding second stage housing straight off piston.

9. Remove two pressure regulator valve assembly retaining screws. Remove valve assembly from second stage housing and discard "O" ring seal.

10. Disconnect distributor arm tension spring from swivel arm.

11. Remove actuating arm retaining screw and arm.

12. Piston and diaphragm assembly

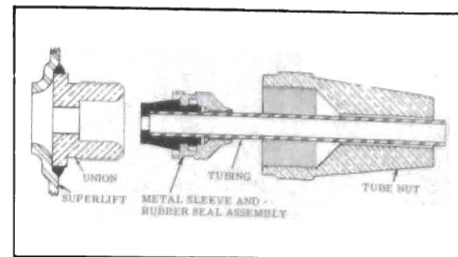

Figure 40-31 - Fitting Nut and Seal

can now be removed from first stage housing by carefully sliding the assembly straight out of housing.

#### b. Disassembly of Piston - Diaphragm Assembly

1. Remove diaphragm retainer with diagonal pliers and discard retainer. See Figure 40-32.

2. Remove diaphragm plate, diaphragm, second diaphragm plate and corprene washer. The diaphragm and corprene washer can be discarded.

3. Remove and discard piston seals and "O" rings from piston.

**NOTE: Be careful not to damage piston.**

4. Remove check valve in second stage end of piston by inserting a suitable punch or piece of 3/32" welding rod through air passage from first stage end and tapping.

#### c. Disassembly of First Stage Housing and Valve Mechanism

Actuate distributor valve with finger.

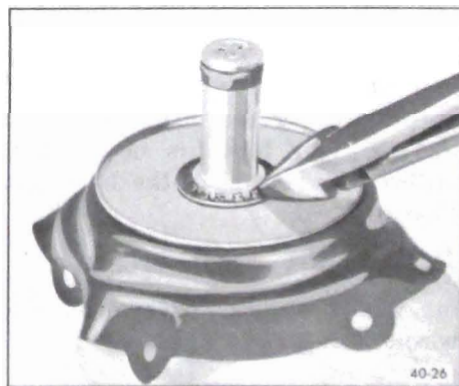

Figure 40-32 - Removing Diaphragm Retainer



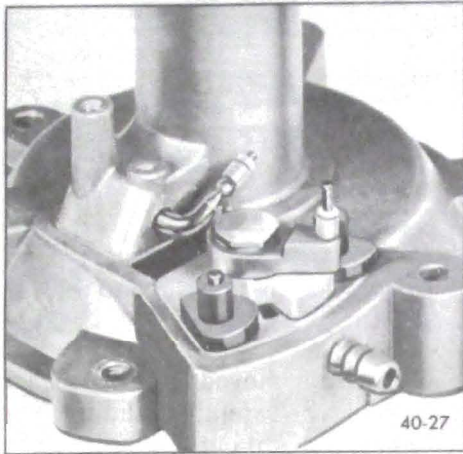

Figure 40-33 - Removal of Distributor Valve

Valve tension spring should press against distributor valve, holding it against either stop. If valve action is not free and positive, it will be necessary to rebuild using new parts in Distributor Valve Package. If action is free and positive and upon disassembly there are no damaged parts, parts may be re-used.

1. Remove screw, washer, distributor arm assembly, washer and distributor valve bushing. See Figure 40-33.
2. Remove two arm assembly stop bushings and two distributor valve stop bushings.
3. Remove distributor valve being careful not to distort valve tension spring.
4. Carefully remove valve tension spring from boss. Do not distort spring.

**NOTE:** Tension spring has one short foot and one long foot. The short foot fits under the distributor valve and the long foot fits into a hole drilled at an angle in the boss. See Figure 40-34.

5. Remove intake check valve retaining spring, intake check valve and washer using a pocket knife.
6. If necessary, remove rocker and swivel arms. Grip pin with pliers and remove pin. See Figure 40-35.

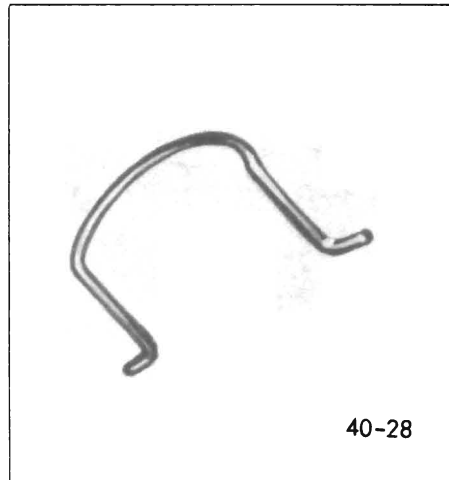

Figure 40-34 - Valve Tension Spring

#### d. Disassembly of Second Stage Housing

Remove check valve in second stage housing by inserting a suitable punch or piece of 3/32" welding rod through air passage and tapping.

### 45-7 CLEANING AND INSPECTION OF PARTS

All metal parts should be cleaned in clean solvent and blown dry with compressed air.

#### a. Piston and Diaphragm Assembly

1. Inspect piston for scoring, replace if necessary.
2. Inspect check valve seat. Seat should be smooth and clean.
3. Inspect diaphragm for holes, looseness or other defect, replace if necessary.

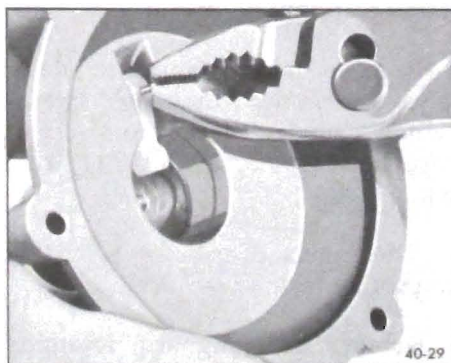

Figure 40-35 - Removing Rocker Arm Pin

#### b. First Stage Housing and Valve Mechanism

1. Inspect housing for cracks or damage and replace if necessary.
2. Inspect piston bore, replace housing if scored.
3. Inspect check valve seat. Seat should be smooth and clean.
4. Inspect distributor valve parts for wear and replace if necessary.
5. Inspect distributor valve seat on housing for wear. Replace housing if necessary.

#### c. Second Stage Housing

1. Inspect piston bore, replace housing if scored.
2. Inspect check valve seat. Seat should be smooth and clean.
3. Inspect housing for cracks or damage and replace if necessary.

### 45-8 ASSEMBLY OF COMPRESSOR ASSEMBLY

#### a. Assembly of Second Stage Housing

1. Install new check valve and spring.
2. Insert new expansion plug retainer and tap in until it bottoms. See Figure 40-36.



Figure 40-36 - Installing Check Valve



**b. Assembly of First Stage Housing and Valve Mechanism**

1. If removed, position bushings in first stage housing and install rocker arm and swivel arm. Align holes in rocker and swivel arms and install retaining pin, small end first.

**NOTE:** If distributor mechanism failed to operate properly or one or more parts were found defective, use new parts in Distributor Valve and Arm Package during remaining reassembly.

2. Install washer on intake valve and install in first stage housing with intake valve retaining spring.

3. Install longer foot of valve tension spring in boss on first stage housing being careful not to distort spring. See Figure 40-37.

4. Position distributor valve so that short foot of tension spring fits under valve and vertical leg is in slot. See Figure 40-38.

5. Install distributor valve bushing, washer, distributor arm assembly, washer and secure with screw. Tighten to 12 lb.in. See Figure 40-39.

6. Install two distributor valve stop bushings and two arm assembly stop bushings.

**NOTE:** Do not install actuating arm, arm tension spring or arm pivot screw at this time as rocker arm

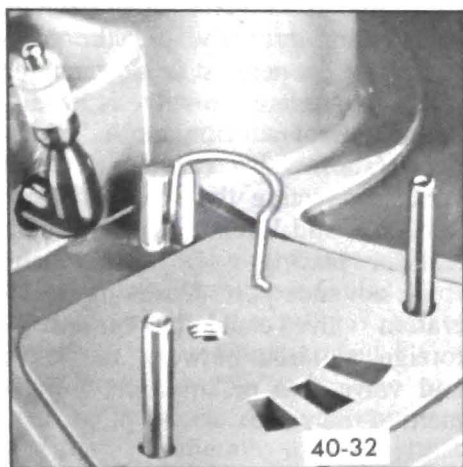

Figure 40-37 - Installing Valve Tension Spring in Boss

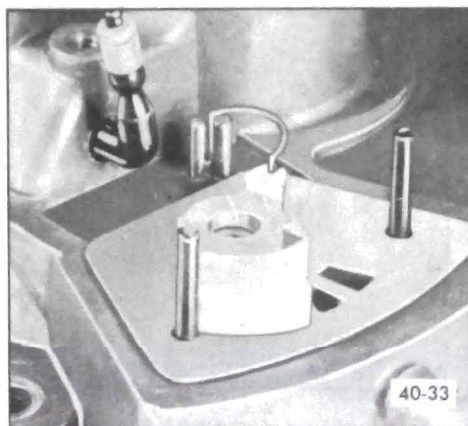

Figure 40-38 - Positioning Distributor Valve

**must be free to permit entrance of piston into first stage housing.**

**c. Assembly of Piston -Diaphragm Assembly**

1. Install new corprene washer, old plate (unless damaged), new diaphragm (with outer lip toward second stage end of piston) and second plate. See Figure 40-40.

2. Using a 13/16 inch deep socket as a retainer installer, press against the piston shoulder on the first stage housing side with wood blocks to seat retainer. The wood blocks used in the illustration are each 3/4" x 3/4" x 12".

**NOTE:** Be sure retainer is securely seated in order to effect an air tight seal against the corprene seal.

3. Install new "O" rings by rolling into groove. Relieve any resulting twist.

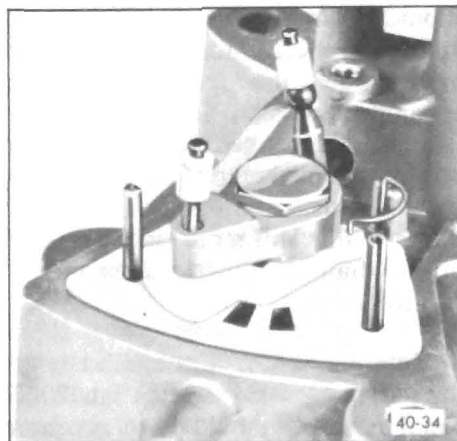

Figure 40-39 - Installing Distributor Arm Assembly

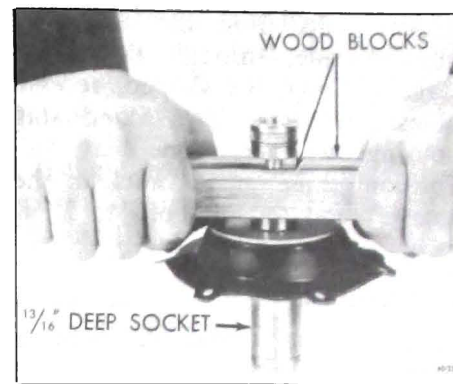

Figure 40-40 - Installing Diaphragm Retainer

4. Install new seals using a piece of .020" shim stock. See Figure 40-41.

**NOTE:** Make sure shim stock has no sharp edges that may cut seal. Do not stretch seal more than is necessary to install. Seals must be installed so they are not twisted.

**d. Assembly of Major Components**

1. Slide piston assembly straight into first stage (large diameter) housing.

2. Install actuating arm and secure to first stage housing with arm pivot screw. Tighten to 12 lb.in.

3. Connect arm tension spring to swivel arm.

4. Rotate piston in first stage housing to align elongated hole in diaphragm with vent port in housing.

5. Install second stage housing by sliding straight onto second stage piston.

6. Install three compressor retaining

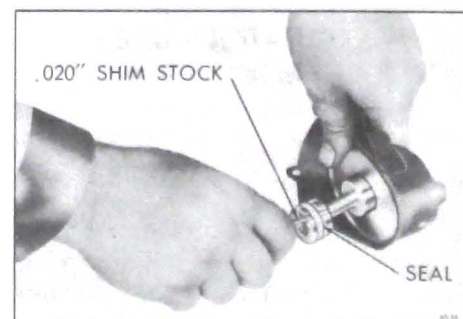

Figure 40-41 - Installing Piston Seal

(short) bolts from the first stage housing side, through the second stage housing hex shaped, recessed holes. The first and second stage housings will align one way only. Position three small nuts in hex recesses and tighten bolts to 28 lb. inch.

7. Install new "O" ring on second stage housing. Install reservoir on second stage housing with three large nuts. Tighten to 28 lb. inch. Install the two reservoir retaining (long) bolts, from reservoir side, that do not go through cover. Tighten to 28 lb. inch.

8. Install new gasket and cover and secure with retaining screw. Tighten screw to 35 lb. inch. Install third reservoir retaining (long) bolt. Tighten to 28 lb. inch.

9. Install new "O" ring on pressure regulator and secure with two retaining screws with high pressure fitting toward reservoir. Tighten to 35 lb. inch.

10. Install two adapters and flexible mounts on the two reservoir (long) bolts that do not go through cover. Tighten to 28 lb. inch.

11. Compressor should be output tested before installation on car. See Division IV, Compressor Output Test on Car.

12. If compressor passes output test, install Compressor, Reservoir and Regulator Valve Assembly on car.

#### 45-9 INSTALLATION OF COMPRESSOR, RESERVOIR AND REGULATOR VALVE ASSEMBLY

1. Install assembly in brackets and tighten nuts to 30 lb. inch.

2. Connect high pressure line to regulator valve and tighten fitting nut to 70 lb. inch. Install vacuum line to compressor.

3. Inflate system through service

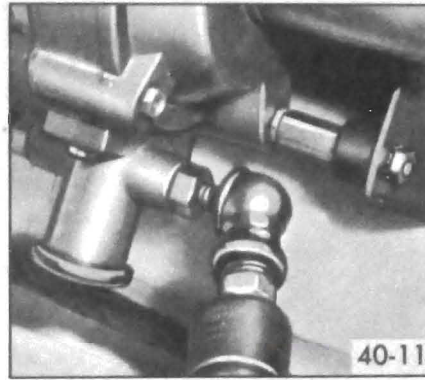

Figure 40-42 - Filling System Through Service Valve

valve to maximum available pressure. See Figure 40-42.

**NOTE: If available pressure is less than 140 psi, start engine to build up reservoir to this pressure.**

## DIVISION IV TROUBLE DIAGNOSIS

### 45-10 QUICK CHECK OF AUTOMATIC LEVEL CONTROL SYSTEM

#### a. Trim Height

1. Record rear trim height of car at curb weight (basic car with fuel tank full). Measure from ground to lower edge of rear wheel cutout.

2. Place 200 pounds of weight in trunk area of passenger cars or on the tail gate of station wagons. Car should begin to level in 4-22 seconds at 700F. Final position should be no more than one inch lower than original dimension. If the dimension is more than one inch lower than original, jounce rear of car to neutralize rear suspension and recheck. If dimension is still more than one inch lower than original, adjust height control valve.

3. Remove weight. Car should begin to settle in 4-18 seconds at 700F. Final position should vary no more than 1/2 inch from original dimension. If the dimension varies more than 1/2 inch from original, jounce

rear of car to neutralize rear suspension and recheck. If variation still exists, adjust height control valve.

**NOTE: To properly service the automatic level control, it will be necessary to obtain Test Gage J-22124 or equivalent.**

#### b. Vacuum Regulator Valve

##### I. Slow Engine Idle

The compressor should not operate during slow engine idle conditions. (V-8 engines with automatic transmission in drive and accessories turned off 550 RPM - V-8 engines with manual transmission in neutral and accessories turned off 700 RPM). If the compressor operates during slow engine idle, the problem could be either a leaking relay valve or an improperly adjusted deceleration valve.

(a) It can be determined whether or not the relay valve is leaking by disconnecting and plugging the hose from the vacuum source port of the vacuum regulator valve. In doing this, the relay valve is isolated to spark advance vacuum which at slow idle speed is nearly non-existent. This then indicates that if the compressor is operating, the relay valve is leaking, thus, permitting P.C.V. vacuum to activate the compressor. If the relay valve is leaking the vacuum regulator valve assembly must be replaced.

(b) If the relay valve checks out to be working properly and the compressor still operates at slow engine idle, the deceleration valve is leaking or in need of adjustment. A leaking deceleration valve can be detected by disconnecting the spark advance port hose and listening for a vacuum leak or placing a finger over the spark advance port. A leaking deceleration valve could be caused by foreign material between the valve and valve seat or improper adjustment of the valve.

The deceleration valve adjusting screw can be turned counterclockwise to lessen the spring tension on



the valve which then requires less vacuum to open the valve. By turning the adjusting screw clockwise, more spring tension is applied on the valve, thus, requiring greater vacuum for it to open.

To properly adjust the valve, turn the adjusting screw clockwise (if compressor is operating at slow idle) until the compressor stops. From this point turn the adjusting screw 1/2 turn clockwise for final setting.

## 2. Fast Idle

With the engine operating at fast idle (above 1000 RPM), the compressor should be in operation unless balanced pressures exist in the system (150-275 psi). If a balanced pressure condition does exist, deflate the system until the compressor begins to operate. Remove the hose from the intake manifold port of the vacuum regulator valve to make certain the deceleration valve is inoperative and plug the hose. If the compressor fails to operate after being deflated, either the restriction (orifice) is plugged, a vacuum leak exists in the P.C.V. or compressor hose or the relay valve is faulty.

(a) If the restriction is plugged, remove the spark advance port hose and use a piece of tag wire or something similar to dislodge the foreign material, connect the manifold port hose to its port, accelerate the engine and let it decelerate as this will cause the deceleration valve to open and allow manifold vacuum to remove the foreign material from the spark advance port. Disconnect the manifold port hose and plug it. Connect the spark advance hose to its port.

(b) If there are no apparent vacuum leaks and the compressor still fails to operate, bypass the relay valve by removing the compressor and P.C.V. hose from the relay valve and connect them together. If the compressor starts to operate, the problem is in the relay valve, requiring the replacement of the vacuum regulator valve assembly.

## 3. Deceleration Condition

When the engine is operating in a deceleration condition, the compressor should be working if the system pressure is low. Deflate if necessary. Disconnect spark advance port hose and plug it. Cap or cover the spark advance port. With a vacuum gage installed in the manifold vacuum line, accelerate engine and let it decelerate. The deceleration valve should open at 18.3" of vacuum and thus actuate the relay valve which in turn permits the compressor to operate on P.C.V. vacuum. The deceleration valve can be adjusted if necessary by removing the protective cap and turning the adjusting screw clockwise to increase the amount of vacuum required to open the valve or counterclockwise to decrease the amount of vacuum required to open this valve. If the deceleration valve is faulty the vacuum regulator assembly must be replaced as a unit.

## 45-11 COMPRESSOR OUTPUT TEST - ON CAR

1. With all engine operated accessories turned off and ignition turned off, deflate system through service valve. Remove high pressure line at regulator and connect test gage.
2. Inflate reservoir to 70 psi through service valve.
3. Observe test gage for evidence of compressor air leak.
4. If leaking, proceed to leak test of the compressor, reservoir and regulator as outlined in paragraph 45-14. If not leaking, continue with this test.
5. With engine running at 1000 RPM, observe reservoir pressure build-up for five minutes. Reservoir pressure should build up from 70 psi to a minimum of 90 psi.
6. If compressor fails to operate, by-pass the relay valve by connecting the P.C.V. hose to the compressor hose and repeat Step 5.

**NOTE: Make certain restriction orifice is not plugged.**

7. If compressor fails to cycle, make sure the vacuum line and filter are open and unobstructed before removing compressor for repair.

8. If build-up is too slow, proceed to repair compressor as outlined in Division III.

9. Satisfactory build-up indicates system problem to be in the control section. See paragraph 45-13. However, again observe the test gage for evidence of an air leak and proceed accordingly.

## 45-12 PRESSURE REGULATOR TEST

Performance test the regulator with a known good compressor on the car.

1. Deflate system through service valve and disconnect line at pressure regulator valve. Install test gage on regulator valve high pressure fitting. See Figure 40-43.

2. Inflate system through service valve to maximum available pressure. See Figure 40-42.

**NOTE: If available pressure is less than 140 psi, start engine to build-up reservoir to this pressure.**

3. Regulated pressure should build-up to and hold steady at 100-130 psi on test gage.

4. Check regulated pressure by mo-

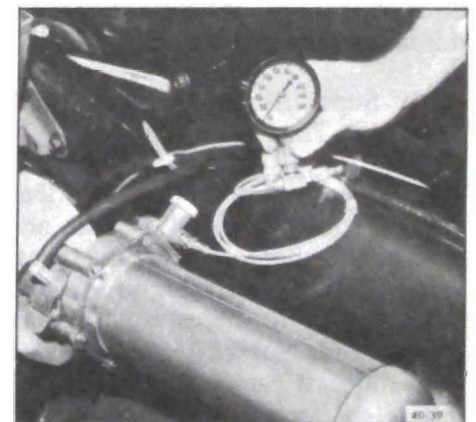

Figure 40-43 - Test Gage Installed on Regulator Valve

mentarily (not more than one second) depressing valve core on test gage and observe gage reading.

5. If regulated pressure now reads less than 100 psi, replace regulator assembly.

6. If regulated pressure exceeds 130 psi, replace regulator assembly.

### 45-13 HEIGHT CONTROL VALVE TEST

#### a. Exhaust (Superlifts Inflated)

1. Disconnect overtravel lever from link.

2. Hold lever down in exhaust position until Superlifts deflate or for a minimum of 18 seconds.

3. If Superlifts deflate, perform Intake Check.

4. If Superlifts do not deflate, remove exhaust adapter from control valve and hold lever down as in Step 2. Replace adapter, "O" ring and filter if this deflates Superlifts.

5. Replace control valve if none of the above steps corrects problem.

#### b. Intake (Reservoir Pressure 125 psi Minimum)

1. Disconnect overtravel lever from link.

2. Hold lever up in intake position until Superlifts inflate or for a minimum of 18 seconds.

3. If Superlifts inflate and hold, proceed to Time Delay Check.

4. If Superlifts inflate and then leak down, perform leak test on lines and fittings and then on Superlifts, paragraph 45-14, subparagraph c. Also check and, if necessary, replace intake and Superlift screens and "O" rings. If Superlifts still do not inflate, perform leak test on valve, paragraph 45-14, subparagraph b. Repair as indicated and proceed to time-delay check.

#### c. Time Delay Check

1. Disconnect overtravel lever from link.

2. Disconnect lines at Superlift and intake ports.

3. Connect test gage to intake valve port and open air pressure (95 psi). Move overtravel lever approximately one inch down from neutral position as measured from end of lever.

4. Quickly move overtravel lever upward two inches; at the same time, begin timing number of seconds before air starts to escape from Superlift port. This delay should be from 4-18 seconds at 70°F. Repeat check. This will check the air intake time delay. Proceed with check to determine air exhaust time delay.

5. Remove test gage and plug intake port with Fill Valve J-21999.

6. Connect test gage to Superlift port and open air pressure (95 psi). Move overtravel lever approximately one

inch up from neutral position as measured from end of lever.

7. Quickly move overtravel lever downward two inches; at the same time, begin timing number of seconds until air begins to escape from exhaust port. This delay should be 4-18 seconds at 70°F. Repeat check.

If either delay is not within specification, there has either been a loss of silicone fluid or valve has lost its adjustment due to damage or wear. Valve must be replaced.

### 45-14 LEAK TEST

#### a. Compressor, Reservoir and Regulator

1. Remove assembly intact.

2. Connect test gage to regulator. Inflate reservoir through service valve to 80-110 psi.

3. Route an 8" piece of rubber hose between vacuum and vent ports. See Figure 40-44.

4. While holding assembly in a vertical position with reservoir end

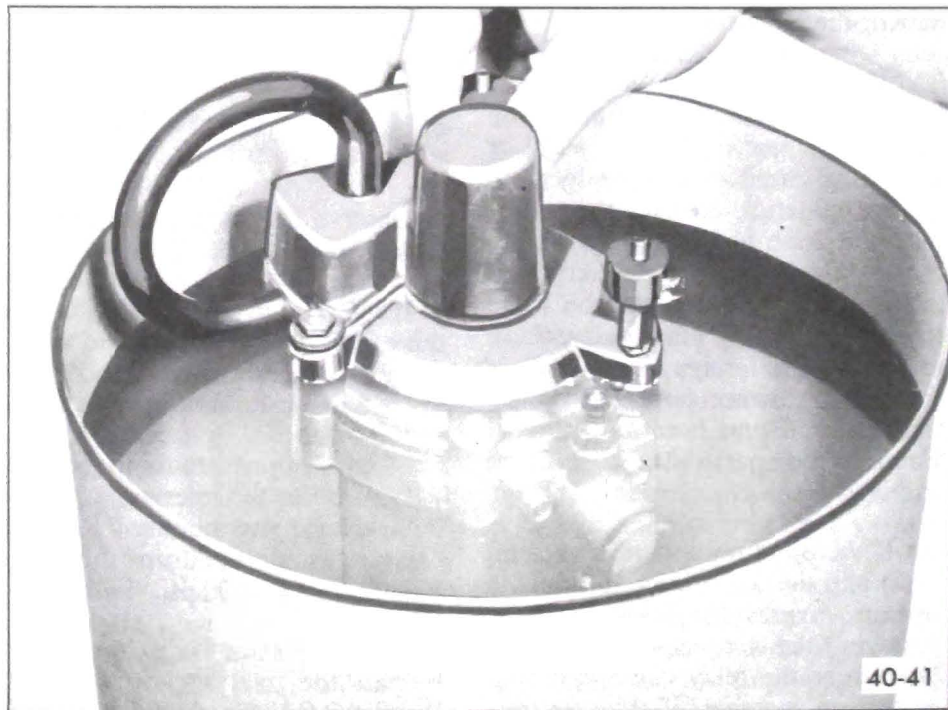

Figure 40-44 - Checking Compressor, Reservoir Tank and Regulator for Leaks

down, immerse in water until diaphragm is just submerged. Do not submerge completely, as water can enter around the cover gasket. Observe for air leaks at:

Reservoir weld seam.

Reservoir to compressor "O" ring. A stream of bubbles may appear in this area and then cease. The bubbles are caused by atmospheric air being purged from air pockets in the second stage housing. If the bubbles stop, there is no leak.

Regulator to compressor "O" ring.

Regulator boot-defective internal "O" ring.

Diaphragm between first and second stage housings - tightening through-bolts may correct the leak.

Service valve.

Test gage connections.

5. Remove hose from vacuum port and submerge disconnected end in water. Cover vacuum port with finger. Do not permit water to enter through vacuum port. If bubbles are evident, the probable cause is defective second stage housing check valve.

6. Correct any leaks by either tightening screws or replacing parts.

7. If the cover gasket area is inadvertently submerged, remove cover and tilt unit so that water may drain through openings by distributor valve mechanism. Move distributor valve from side to side until all water is purged. Blow dry with compressed air, both the distributor valve mechanism and interior of the cover. Replace cover.

If the compressor passes this test, yet fails the output test, the compressor, reservoir and regulator need to be overhauled.

#### b. Control Valve

1. Remove control valve from car.

2. Clean exterior of control valve thoroughly.

3. Connect test gage and air pressure source to intake adapter and open air pressure (80-110 psi).

4. Submerge unit in water. No air should escape if overtravel lever is in "neutral" position. If bubbles escape from Superlift port, replace control valve.

5. Shut off air pressure and detach test gage from air intake port. Plug intake port with Fill Valve, J-21999.

6. Connect test gage to Superlift port and open air pressure.

7. With overtravel lever in "neutral" position, no air should escape. If bubbles escape from exhaust port, replace control valve.

8. If air escapes around edge of cover plate, the gasket must be replaced.

9. Remove control valve from water. Actuate overtravel lever to expel any water from unit.

10. Shut off air pressure and remove line from Superlift port.

#### C. Lines and Fittings

1. Disconnect overtravel lever from link.

2. Hold lever up in intake position for maximum Superlift inflation and release.

3. Leak check all connections with a soap and water solution.

#### d. Superlifts

1. Disconnect lines and remove Superlift from car.

2. Inflate individually to 50-60 psi utilizing Fill Valves J-21999. submerge in water and observe for leaks.

3. Install Superlifts and connect lines.



## 45-15 DIAGNOSIS CHART

Condition	Cause	Correction
Car loaded, will not raise.	<p>External damage or breakage.</p> <p>Line leak.</p> <p>Control valve setting incorrect.</p> <p>Defective component.</p>	<p>Visually inspect —            Lines            Link            Control valve            Superlifts</p> <p>Leak Test — Lines and fittings.</p> <p>Perform trim adjustment on car.</p> <p>Perform system test and proceed as indicated.</p>
Car loaded. Raises to level and then leaks down.	<p>Line leak.</p> <p>Control valve exhaust leak.</p> <p>Superlift leak.</p> <p>Control valve leak.</p>	<p>Leak test lines and fittings from control valve to Superlifts and crossover line.</p> <p>Control valve test — on car.</p> <p>Leak test Superlifts.</p> <p>Leak Test — Control Valve Off Car.</p>
Car loaded, raises partially.	<p>Load excessive (over 500 lbs. at axle) on cars with special springs.</p> <p>Control valve setting incorrect.</p> <p>Low supply pressure.</p>	<p>Distribute load, shift forward if practical.</p> <p>Perform trim adjustment on car.</p> <p>Perform compressor output test on car.</p>
Car unloaded, rides too high, will not come down.	<p>Control valve setting incorrect.</p> <p>External damage or breakage.</p> <p>Defective control valve.</p> <p>Supply line and Superlift line reversed.</p>	<p>Perform trim adjustment on car.</p> <p>Visually inspect —            Lines            Link            Control Valve            Superlifts</p> <p>Control valve test.</p> <p>Install lines in correct locations.</p>
Car rises when loaded but leaks down while driving.	<p>Time delay mechanism not functioning properly.</p>	<p>Check time delay mechanism.</p>
Compressor will not operate during fast idle or cruising speeds. (Low system pressure.)	<p>Plugged restriction orifice.</p> <p>Defective relay valve.</p> <p>Vacuum leak.</p> <p>Faulty compressor.</p>	<p>Clean restriction orifice.</p> <p>Replace vacuum regulator valve assembly.</p> <p>Inspect for and correct.</p> <p>Correct as necessary.</p>

## 45-15 DIAGNOSIS CHART (Cont'd)

Condition	Cause	Correction
Compressor operates at slow idle speed. (Low system pressure.)	Defective relay valve. Intake manifold leak. Improper deceleration valve spring adjustment. Excessive spark port vacuum.	Replace vacuum regulator valve assembly. Readjust deceleration valve spring screw. Check out engine vacuum.
Compressor will not operate during deceleration period. (Low system pressure.)	Defective deceleration valve. Improper valve spring adjustment. Vacuum leak. Faulty Compressor.	Replace vacuum regulator valve assembly. Readjust decelerator valve spring screw. Inspect for and correct. Correct as necessary.