

# SECTION B

## 45-46-48-49000 FRONT SUSPENSION

### CONTENTS

Division	Subject	Paragraph
I	SPECIFICATIONS AND ADJUSTMENTS:	
	Bolt Torque Specifications .....	30-1
	Dimensional Specifications .....	30-2
II	DESCRIPTION AND OPERATION:	
	Suspension Description .....	30-3
III	SERVICE PROCEDURES:	
	Front Wheel Alignment .....	31-1
	Removal and Installation of Ball Joints and Steering Knuckle .....	31-2
	Removal and Installation of Upper Control Arm Assembly .....	31-3
	Removal and Installation of Lower Control Arm Assembly .....	31-4
	Removal and Installation of Front Springs .....	33-1
	Shock Absorber Service .....	36-1
	Removal and Installation of Stabilizer Bar .....	37-1
	Removal and Installation of Brake Reaction Rods .....	37-2
IV	TROUBLE DIAGNOSIS:	
	Faulty Springs, Shock Absorbers, and Ball Joints .....	37-3

## DIVISION I SPECIFICATIONS AND ADJUSTMENTS

### 30-1 BOLT TORQUE SPECIFICATIONS

Use a reliable torque wrench to tighten the parts listed to insure tightness without straining or distorting parts. These specifications are *for clean and lightly lubricated* threads only; dry or dirty threads produce increased friction which prevents accurate measurement of tightness.

Parts	Location	Torque Lb. Ft.
Nut & Bolt	Brake Reaction Rod to Lower Control Arm .....	55
Nut	Brake Reaction Rod to Frame .....	50
Bolt & Nut	Front Shock to Lower Control Arm .....	35
Nut	Front Shock to Frame .....	8
Bolt	Stabilizer Bushing to Frame .....	20
Nut	Upper Control Arm Shaft to Frame .....	75
Nut	Upper Ball Joint to Knuckle .....	35
Bolt & Nut	Front Lower Control Arm to Frame .....	100
Nut	Lower Ball Joint to Knuckle .....	85
Nut	Stabilizer Link to Lower Control Arm .....	8

### 30-2 DIMENSIONAL SPECIFICATIONS

Stabilizer Bar Diameter .....	25/32"
Steering Knuckle Spindle	
Large End .....	1.3743-1.7348
Small End .....	.8430-.8435

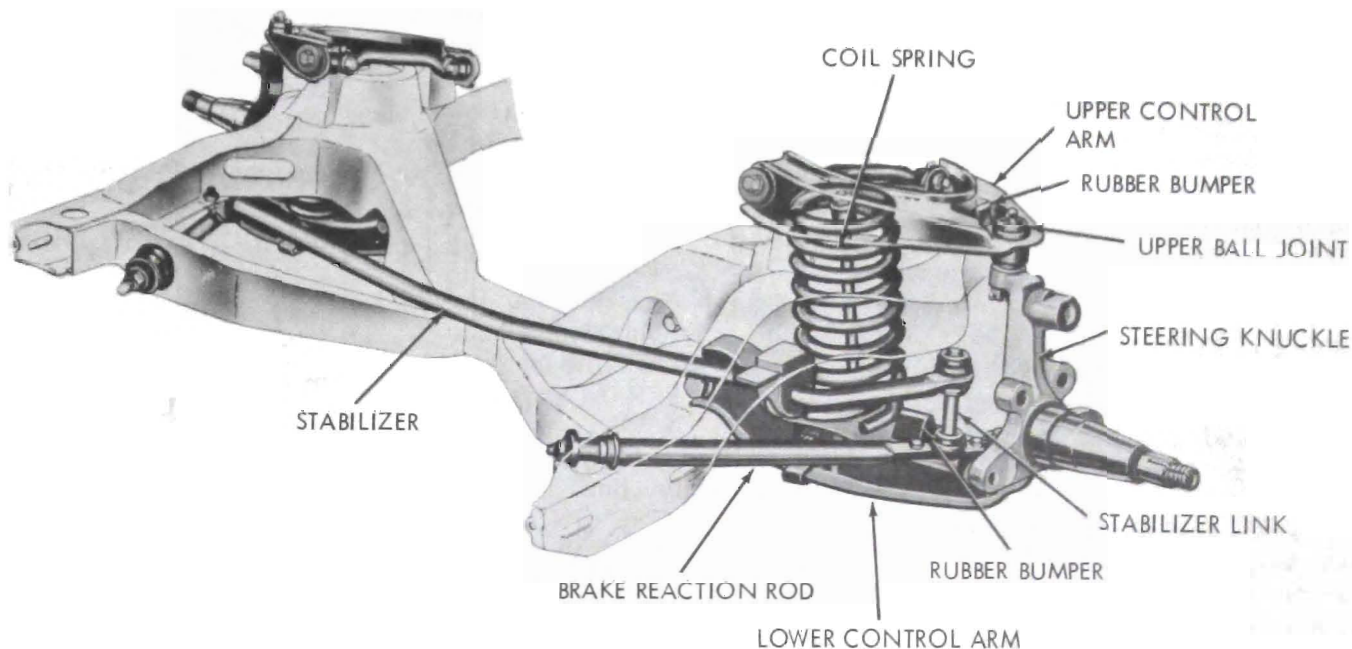

30-25 A

Figure 30-27 - Front Suspension

## DIVISION II

### DESCRIPTION AND OPERATION

#### 30-3 SUSPENSION DESCRIPTION

The front suspension on the 1969 Buick is designed to allow each wheel to compensate for changes in the road surface level without appreciably affecting the opposite wheel. Each wheel is independently connected to the frame by a steering knuckle, ball joint assemblies, and upper and lower control arms. The control arms are specifically designed and positioned to allow the steering knuckles to move in a prescribed three dimensional arc. The front wheels are held in proper relationship to each other by two tie rods which are connected to steering arms on the knuckles and to an intermediate rod.

Coil chassis springs are mounted between the spring housings on the frame and the lower control arms. Ride control is provided by double, direct acting shock absorbers mounted inside the coil springs and attached to the lower control arm by bolts. The upper portion of each shock absorber extends through the spring housing and is secured with two grommets, two grommet retainers, and a nut.

Side roll of the front suspension is controlled by a spring steel stabilizer shaft. It is mounted in rubber bushings which are held to the frame side rails by brackets. The ends of the stabilizer are connected to the lower control arms by means of links which are isolated by rubber grommets which provide flexibility and prevent rattles.

A ball joint is pressed into the outer end of the upper arm. The upper control arm is attached to a cross

shaft through rubber bushings. The cross shaft, in turn, is bolted to frame brackets. It is spring loaded to insure proper seating of the ball in the socket.

The inner ends of the lower control arms are bolted to the frame front cross member through rubber bushings. The outer end of each arm is connected to the steering knuckle with a ball joint assembly pressed in the lower control arm and bolted to the steering knuckle. Fore-aft alignment of the lower control arm is maintained by a brake reaction rod. The brake reaction rod is also attached to the frame through special rubber isolators.

Rubber seals are part of the ball joint assemblies to keep dirt and moisture from entering the joint and damaging bearing surfaces.

Shock absorbers are Delco direct double-acting type. Details on the

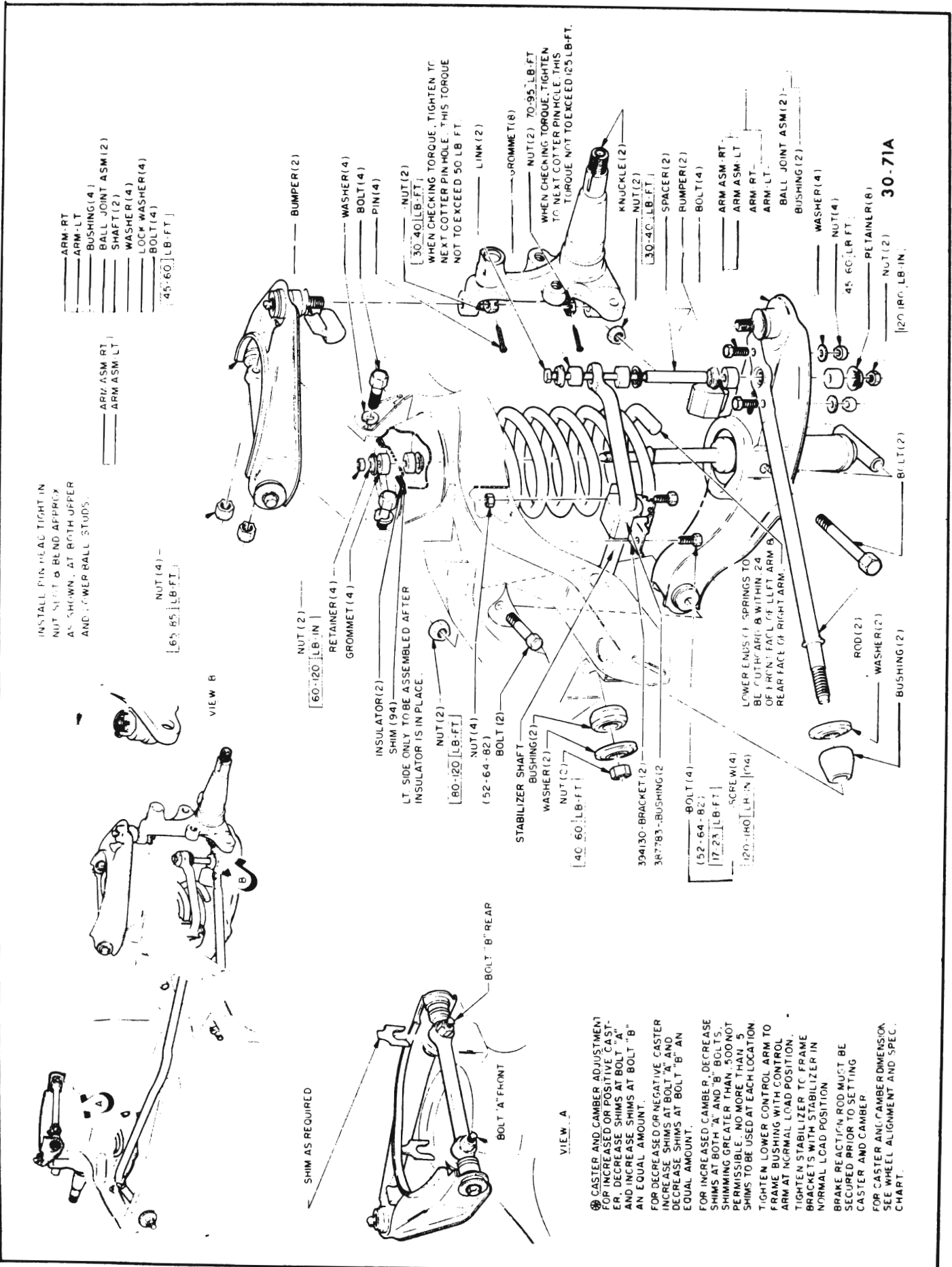

Figure 30-28 - Front Suspension Details

Ⓢ **CASTER AND CAMBER ADJUSTMENT FOR INCREASED OR POSITIVE CAST-ER, INCREASE SHIMS AT BOLT "A" AND DECREASE SHIMS AT BOLT "B" AN EQUAL AMOUNT.**

Ⓢ **FOR DECREASED OR NEGATIVE CASTER INCREASE SHIMS AT BOLT "A" AND DECREASE SHIMS AT BOLT "B" AN EQUAL AMOUNT.**

Ⓢ **FOR INCREASED CAMBER, DECREASE SHIMS AT BOTH "A" AND "B" BOLTS. SHIMMING GREATER THAN .500 NOT PERMISSIBLE. NO MORE THAN 5 SHIMS TO BE USED AT EACH LOCATION.**

Ⓢ **TIGHTEN LOWER CONTROL ARM TO FRAME BUSHING WITH CONTROL ARM AT NORMAL LOAD POSITION.**

Ⓢ **TIGHTEN STABILIZER TO FRAME BRACKETS WITH STABILIZER IN NORMAL LOAD POSITION.**

Ⓢ **BRAKE REACTION ROD MUST BE SECURED PRIOR TO SETTING CASTER AND CAMBER.**

Ⓢ **FOR CASTER AND CAMBER DIMENSION, SEE WHEEL ALIGNMENT AND SPEC. CHART.**

operation of this type of shock absorber can be found under paragraph 30-4, Section A.

## DIVISION III

### SERVICE PROCEDURES

#### 31-1 FRONT WHEEL ALIGNMENT

Wheel alignment is the process of adjusting the position of the front wheels in order to attain proper vehicle handling characteristics and the least steering effort with a minimal amount of tire wear.

Wheel and tire balance has an important effect on steering and tire wear. If wheels and tires are out of balance, "shimmy" or "tramp" may develop causing tires to wear unevenly and give the erroneous impression that the wheels are not in proper alignment. For this reason, the wheel and tire assemblies should be known to be in proper balance before assuming that the front suspension is out of alignment.

Close limits on front wheel caster, camber, and theoretical king pin inclination are necessary for proper car handling, but require only reasonable accuracy to provide normal tire life. With the type of front suspension used, the toe-in adjustment is usually more important than caster and camber as far as tire wear is concerned.

In the majority of cases, services consisting of inflating tires to specified pressure and interchanging tires at recommended intervals, balancing all wheels and tires, adjusting steering gear and setting toe-in correctly will provide more improvement in car handling and tire wear than will front end alignment adjustments.

The correct use of accurate front end alignment equipment is essential to determine whether front suspension parts have been damaged, and to obtain correct alignment settings after new parts have been installed.

#### a. Inspection Before Checking Front Wheel Alignment

Before making any adjustment affecting caster, camber, toe-in, theoretical king pin inclination, or steering geometry, the following checks and inspections should be made to insure correctness of alignment equipment readings and alignment adjustments.

1. Front tires should have approximately the same wear and all tires must be inflated to specified pressures (par. 100-1).
2. Check front wheel bearings for looseness and adjust if necessary (par. 100-4).
3. Check for run-out of wheels and tires.
4. Check wheels and tires for balance and correct if out-of-balance (par. 100-3).
5. Check for looseness at ball joints and tie rod ends; if found excessive, it must be corrected before alignment readings will have any value.
6. Check shock absorber action and correct if necessary.
7. Check trim height; if out of limits, correct with shims or replace spring.

**CAUTION: Consideration must be given the optional equipment on the car, undercoating, dirt, etc. Vehicle should be at curb or free height when an alignment operation is performed. (All excess equipment, such as tool boxes, fishing or golfing equipment, should be removed from the vehicle.) The vehicle should have a full tank of fuel.**

Good judgment should be exercised before replacing a spring when car trim height is only slightly out of limits. Spring replacement under conditions of excessive weight as mentioned above will accomplish little and must be accompanied by shimming to obtain satisfactory results. Front and rear shims are available through the Parts Depart-

ment. Refer to paragraph 37-2 for front springs and Group 40 for rear springs.

8. It is advisable to check the condition and accuracy of any equipment being used to check front end alignment and to make certain that instructions of the manufacturer are thoroughly understood and followed.

#### b. Checking Caster and Camber Settings

Since caster and camber settings are both adjusted by shimming in the same locations, both of these settings must be checked before changing shims.

**CAUTION: Regardless of equipment used to check caster and camber, the car must be on level surface both transversely and fore and aft.**

When alignment equipment is used which bears against the tire or wheel rim to obtain readings, it is very essential that the tires or wheels be checked for lateral run-out.

Caster and camber readings must be taken at points on the wheels which have no run-out or which lie in the same plane. Caster and camber should be within limits shown in Figure 30-30. Note that the caster angles at both front wheels need not be exactly the same but must be within 1/2 degree of each other. Likewise, the camber angles on both sides must be within 1/2 degree of each other. If caster and camber are not within the specified limits, adjust in the following manner.

#### c. Caster and Camber Adjustment

For caster and camber adjustment purposes, use the following guide:

1. To increase camber only - (More positive) Remove and equal amount of shims from front and rear bolts.
2. To decrease camber only - (Less positive) add an equal amount of shims to front and rear bolts.
3. To increase caster only - (More positive) Remove an amount of

shims from front bolt and add an equal amount of shims at rear bolt.

4. To decrease caster only - (Less positive) Add an amount of shims at the front bolt and remove an equal amount of shims from the rear bolt.

5. To increase caster and camber at the same time - remove an amount of shims at front bolt only.

6. To decrease caster and camber at the same time - add an amount of shims at front bolt only.

The following guide lines will help you select and correctly shim with minimum effort. Shim thickness limit for any one stack is .600 of an inch.

Shims are available in .030", .060", .100" and .200" thickness.

By adding a pack of shims .090" thick at both sides, camber will be decreased by 1/2 degree.

By adding a .030" shim on one bolt and removing a .030" shim from the other, caster will change 3/8 degree.

To help you determine the shim thickness change required to return caster and camber to design dimension, two dimension change charts have been developed to enable you to do quicker and more accurate work. See Figures 30-29 and 30-29A. These charts indicate in thousandths of an inch, the change required at (F) front and (R) rear shim position in order to return your initial reading to factory specifications. For example: Assume the initial readings for one B Series wheel were, camber + 3/4 degrees and caster + 1-1/2 degrees. Figure 30-29 indicates that an addition of +0.180 shim thickness to the (F) front shim position and addition of +0.080 shim thickness to the (R) shim position would be required to adjust this wheel to factory specifications.

Torque control arm shaft nuts to:

75 lb. ft. on 45-46-48-49000 Series.

*It is imperative that these torque specifications be closely adhered to.*

**d. Checking Theoretical Kingpin (Steering Axis) Inclination**

**CAUTION:** When checking theoretical king pin inclination, car must be on a level surface both transversely and fore and aft, must have trim heights within limits, and must be at curb load.

Set camber and caster to the desired specifications as shown in Figure 30-30. Measure king pin or steering axis inclination relative to a vertical plane. Add to the measured king pin axis angle the value of the positive camber angle (subtract if the camber is negative) and compare the resulting angle to the value given in Figure 30-30.

There is no adjustment for theoretical king pin inclination as this factor depends on the accuracy of the front suspension parts. Distorted steering knuckles should be replaced with new parts.

**CAUTION:** Any heating, welding, or bending of front suspension parts to correct errors or repair damage must be avoided as this may produce soft spots in the metal in which fatigue and breakage may develop in service.

**e. Checking and Adjusting Toe-In**

**CAUTION:** Car must be at curb weight and front and rear suspension trim should be within specified limits. Bounce front end and allow it to settle to operating height. Steering gear and front wheel bearings must be properly adjusted with no looseness at tie rod ends. The car should be moved forward one complete revolution of the wheels before the toe-in check and adjustment are started and the car should never be moved backward while making the check and adjustment. This presets the front suspension and removes lash from the joints.

1. Turn steering wheel to straight-ahead position, with front wheels in same position.

2. Using a suitable toe-in gauge, measure the distance between out-

side walls of tires at the front at a height approximately horizontal to floor and through the centerline of the wheel assembly. See Figure 30-30.

**NOTE:** An accurate check also can be made by raising and rotating front wheels to scribe a fine line near the center of each tire, then, with tires on the floor and front end at running height, measure between scribed lines with a suitable trammel.

4. Roll the car forward until measuring points on tires are approximately 180° from point used in Step 3 above.

The measurement at the front should be 7/32" to 5/16" less than the measurement at the rear.

5. If toe-in is not within specified limits, loosen clamp bolts and turn adjusting sleeves at tie rod ends as required. Decrease toe-in by turning left sleeve in same direction as wheel rotates moving forward and turn right sleeve in opposite direction. Increase toe-in by turning both sleeves in opposite direction.

**CAUTION:** Left and right adjusting sleeves must be turned exactly the same amount but in opposite directions when changing toe-in, in order to maintain front wheels in straight-ahead position when steering wheel is in straight-ahead position.

Approximately the same amount of thread engagement in the adjuster sleeve should be noted for the inner and outer tie rod ends. The distance between the inner and outer tie rod ends in the adjuster sleeve should be approximately equal for both right and left wheels. The tie rods should never be lengthened to the point where the inner and outer threaded tie rod ends are outboard of the inner edge of the adjuster sleeve "U" clamps. If proper toe-in cannot be obtained within this amount of adjustment, inspect the suspension and steering linkage for bent parts.

6. After correct toe-in is secured, tighten clamp bolts securely.

FRONT SUSPENSION ALIGNMENT CHART  
1969 B-C SERIES  
CURB CONDITION

		MEASURED CASTER (Degrees)											
		2°	1¾°	1½°	1¼°	1°	¾°	½°	¼°	0°	-¼°	-½°	
MEASURED CHAMBER (Degrees)	1¼°	F	0.31	0.29	0.28	0.26	0.24	0.22	0.21	0.20	0.18	0.16	0.15
		R	0.14	0.16	0.18	0.20	0.22	0.24	0.26	0.27	0.29	0.31	0.33
	1°	F	0.26	0.24	0.23	0.22	0.20	0.18	0.16	0.15	0.14	0.12	0.10
		R	0.10	0.12	0.13	0.15	0.16	0.18	0.20	0.22	0.24	0.26	0.28
	¾°	F	0.22	0.20	0.18	0.16	0.15	0.14	0.12	0.10	0.09	0.08	0.06
		R	0.04	0.06	0.08	0.10	0.12	0.14	0.16	0.18	0.20	0.22	0.24
	½°	F	0.17	0.16	0.14	0.12	0.10	0.09	0.08	0.06	0.04	0.03	0.02
		R	0	0.02	0.04	0.06	0.08	0.10	0.11	0.13	0.15	0.17	0.19
	¼°	F	0.12	0.11	0.10	0.08	0.06	0.04	0.03	0.02	0	-0.02	-0.03
		R	-0.02	-0.02	-0.01	0.01	0.02	0.04	0.06	0.08	0.10	0.12	0.14
	Desired 0°	F	0.08	0.06	0.05	0.03	0.02	0	-0.02	-0.03	-0.05	-0.06	-0.08
		R	-0.09	-0.07	-0.06	-0.04	-0.02	0	0.02	0.04	0.06	0.08	0.10
	-¼°	F	0.04	0.02	0	-0.02	-0.03	-0.04	-0.06	-0.08	-0.10	-0.11	-0.12
R		-0.14	-0.12	-0.10	-0.08	-0.06	-0.04	-0.03	-0.01	0.01	0.03	0.05	
-½°	F	-0.01	-0.02	-0.04	-0.06	-0.08	-0.10	-0.11	-0.12	-0.14	-0.16	0.16	
	R	-0.18	-0.16	-0.15	-0.13	-0.12	-0.10	-0.08	-0.06	-0.04	-0.02	0	
-¾°	F	-0.06	-0.08	-0.09	-0.10	-0.12	-0.14	-0.16	-0.17	-0.18	-0.20	-0.22	
	R	-0.23	-0.22	-0.20	-0.18	-0.16	-0.14	-0.12	-0.10	-0.08	-0.06	-0.04	
-1°	F	-0.10	-0.12	-0.14	-0.15	-0.16	-0.18	-0.20	-0.22	-0.23	-0.24	-0.26	
	R	-0.28	-0.26	-0.24	-0.22	-0.20	-0.18	-0.17	-0.15	-0.13	-0.11	-0.09	
-1¼°	F	-0.14	-0.16	-0.18	-0.20	-0.21	-0.23	-0.24	-0.26	-0.28	-0.29	-0.30	
	R	-0.32	-0.30	-0.29	-0.27	-0.26	-0.24	-0.22	-0.20	-0.18	-0.16	-0.14	

F Shim required at front bolt (Inches)

+ Means shim addition

R Shim required at rear bolt (Inches)

- Means shim removal

Figure 30-29

FRONT SUSPENSION ALIGNMENT CHART  
1969 E SERIES  
CURB CONDITION

		MEASURED CASTER (Degrees)											
		2¼°	2°	1¾°	1½°	1¼°	Desired 1°	¾°	½°	¼°	0°	-¼°	
MEASURED CHAMBER (Degrees)	1½°	F	0.32	0.30	0.28	0.26	0.25	0.24	0.22	0.20	0.19	0.17	0.16
		R	0.15	0.16	0.18	0.20	0.22	0.24	0.26	0.28	0.30	0.32	0.34
	1¼°	F	0.27	0.25	0.24	0.22	0.20	0.19	0.17	0.16	0.14	0.13	0.11
		R	0.10	0.12	0.14	0.16	0.18	0.20	0.22	0.24	0.26	0.28	0.30
	1°	F	0.22	0.20	0.19	0.17	0.16	0.14	0.12	0.11	0.10	0.08	0.07
		R	0.06	0.08	0.09	0.11	0.13	0.14	0.16	0.18	0.20	0.22	0.24
	¾°	F	0.18	0.16	0.14	0.13	0.11	0.10	0.08	0.06	0.05	0.04	0.02
		R	0.01	0.02	0.04	0.06	0.08	0.10	0.12	0.14	0.16	0.18	0.20
	½°	F	0.13	0.12	0.10	0.08	0.06	0.05	0.03	0.02	0	-0.01	-0.02
		R	-0.04	-0.02	0	0.02	0.04	0.06	0.08	0.10	0.12	0.14	0.16
	Desired ¼°	F	0.08	0.06	0.05	0.03	0.02	0	0.02	0.04	0.06	0.08	0.10
		R	-0.09	-0.07	-0.05	-0.04	-0.02	0	0.02	0.04	0.06	0.08	0.10
0°	F	0.04	0.02	0.01	-0.01	-0.02	-0.04	-0.06	-0.07	-0.09	-0.10	-0.12	
	R	-0.13	-0.11	-0.10	-0.08	-0.06	-0.04	-0.02	0	0.02	0.04	0.06	
-¼°	F	0	-0.02	-0.04	-0.06	-0.07	-0.08	-0.10	-0.12	-0.13	-0.15	-0.16	
	R	-0.18	-0.16	-0.14	-0.12	-0.10	-0.08	-0.06	-0.04	-0.02	0	0.02	
-½°	F	-0.05	-0.07	-0.08	-0.10	-0.12	-0.13	-0.15	-0.16	-0.18	-0.19	-0.21	
	R	-0.22	-0.20	-0.18	-0.17	-0.15	-0.14	-0.11	-0.10	-0.08	-0.06	-0.04	
-¾°	F	-0.10	-0.11	-0.13	-0.14	-0.16	-0.18	-0.19	-0.21	-0.22	-0.24	-0.25	
	R	-0.27	-0.25	-0.24	-0.22	-0.20	-0.18	-0.16	-0.14	-0.12	-0.10	-0.08	
-1°	F	-0.14	-0.16	-0.17	-0.19	-0.21	-0.22	-0.24	-0.25	-0.27	-0.28	-0.30	
	R	-0.32	-0.30	-0.28	-0.26	-0.24	-0.22	-0.20	-0.18	-0.16	-0.14	-0.12	

F Shim required at front bolt (Inches)

R Shim required at rear bolt (Inches)

+ Means shim addition

- Means shim removal

Figure 30-29A

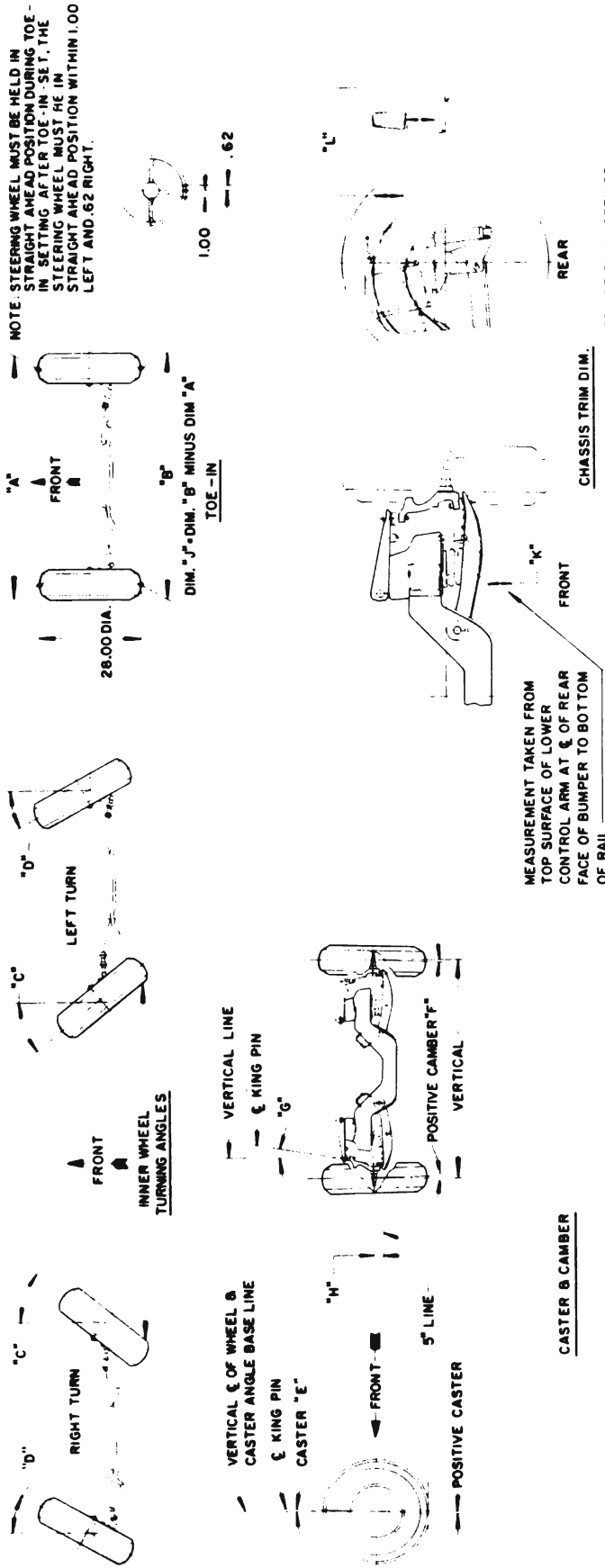

MODEL	CHASSIS TRIM DIMENSION				FULL TURN INNER WHEEL "C"	FULL TURN OUTER WHEEL "D"	OUTER WHEEL ANGLE WITH INNER WHEEL AT 20°	CASTER "F" ± 1/2°	CAMBER "G" ± 1/2°	STEERING AXIS ANGLE "H" AT 0° CAMBER	TRIM HEIGHT "I" DESIGN	TOE IN "J" ± 1/16"
	FRONT "K" ± .18		REAR "L" ± .24									
	CURB WEIGHT	NORMAL LOAD	CURB WEIGHT	NORMAL LOAD								
45237	4.36	3.57	3.68	6.14	3.98	4.03	19-1/2°	3/4° POS	10-3/4° AT 0° CAMBER	2.71	1/4"	
45239	4.30	3.57	3.66	5.92	3.88	3.91	19-1/2°	3/4° POS	10-3/4° AT 0° CAMBER	2.71	1/4"	
45269	4.20	3.57	3.64	5.92	3.88	3.91	19-1/2°	3/4° POS	10-3/4° AT 0° CAMBER	2.71	1/4"	
45437	4.44	3.70	3.79	6.65	5.14	5.28	16-3/4°	1° POS	10-3/4° AT 0° CAMBER	1.68	7/32"	
45439												
45467												
45489												
46437												
46439												
46469												
46637												
46639												
46669												
48257												
48259												
48269												
48457												
48439												
48467												
48489												
49487												

- \* CURB WEIGHT INCLUDES FULL TANK GAS OIL, WATER AND SPARE TIRE
- \* CURB WEIGHT TRIM ON AIR CONDITIONED CARS SUBTRACT .10 FROM FRONT TRIM DIMENSIONS (PASSENGER WEIGHT - 150 LBS.) 52-54-62
- \* NORMAL LOAD TRIM DIMENSIONS DETERMINED WITH 4 PASSENGER LOAD 2 IN FRONT - 2 IN REAR 94
- \* NORMAL LOAD TRIM DIMENSIONS DETERMINED WITH 3 PASSENGER LOAD, 2 IN FRONT - 1 IN REAR

THESE DIMENSIONS DO NOT APPLY TO OPTIONAL SPRINGS

Figure 30-30 - Wheel Alignment and Chassis Trim Chart - 45-46-48-49000 Series



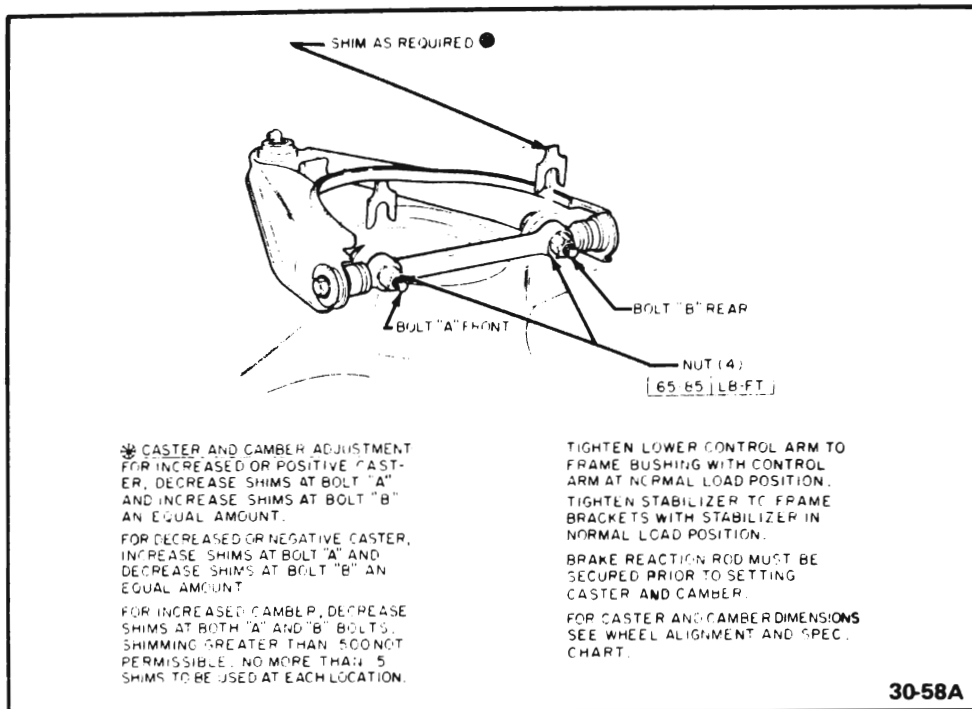

Figure 30-31 - Upper Control Arm Shimming Locations

**CAUTION:** The steering knuckle and steering arm "rock" or tilt as front wheel rises and falls. Therefore, it is of vital importance to center the travel of the inner tie rod joint by centering the tie rod stud in the socket (socket front face should be approximately vertical) and then position the bottom face of tie rod end parallel with machined surface at outer end of steering arm when tie rod length is adjusted. Severe damage and possible failure can result unless this precaution is observed. Tie rod sleeve clamps must be positioned straight down to + or - 15° to provide clearance between the frame and the steering linkage for all combinations of wheel motions.

#### f. Checking Steering Geometry (Turning Angles)

**CAUTION:** Be sure that caster, camber, and toe-in have all been properly corrected before checking steering geometry. Steering geometry must be checked with the weight of the car on the wheels.

1. With the front wheels resting on full floating turntables, turn wheels to the right until the outside (left)

wheel is set at 20 degrees. The inside (right) wheel should then be at the angle specified in Figure 30-30.

2. Repeat this test by turning front wheels to the left until the outside (right) wheel is at 20 degrees; the inside (left) wheel should then be at the angle specified in Figure 30-30.

3. Errors in steering geometry generally indicate bent steering arms, but may also be caused by other incorrect front end factors. If the error is caused by a bent steering arm, the arm must be replaced. Replacement of such parts must be followed by a complete front end alignment check as described above. Never heat or bend a steering arm or knuckle to correct steering geometry, since doing so may cause the arm to break in service.

### 31-2 REMOVAL AND INSTALLATION OF BALL JOINTS AND STEERING KNUCKLE

#### a. Removal and Installation of Upper Control Arm Ball Joint Assembly

The upper control arm and ball joint

assembly is serviced as a complete unit. See paragraph 31-3 for upper control arm removal and installation.

#### b. Lower Ball Joint Removal

1. Raise front of car and place jack stands under frame side rails. Remove wheel with hub and drum assembly attached.

2. Remove the brake backing plate. If the backing plate is wired carefully out of the way, there will be no need to disconnect the brake hose.

3. For safety, place a floor jack under the lower control arm as far outboard on the arm as possible to gain maximum leverage advantage. Do not place the jack against the arm but about 1/2" below. Now remove cotter pin and loosen (do not remove) nut on lower ball joint tapered stud. Nut should be loosened not more than 1/8".

**WARNING:** If jack is not used and nut is removed, injury could result since heavily compressed chassis spring will be completely released.

4. Rap the steering knuckle sharply in the area of the lower ball stud to allow the force of the chassis spring to disengage the tapered ball stud from the knuckle.

**NOTE:** It is sometimes helpful to wedge a block of wood under the upper control arm to provide a solid stop so the lower ball stud can be loosened with a more solid hammer rap.

5. Place the jack under the lower control arm at the spring seat. Raise the jack until compression is relieved on the upper control arm rubber rebound bumper. Remove the lower ball joint stud nut. Move the steering knuckle out of the way.

6. Install lower ball joint remover and installer as shown in Figure 30-32.

7. Tighten Detail J-9519-8 with a socket and handle as shown in Figure 30-33 until ball joint is forced out of the lower control arm.

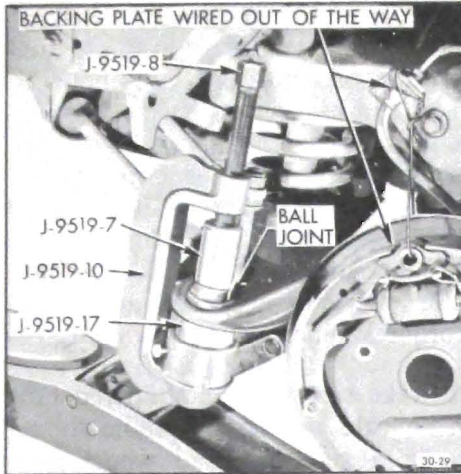

Figure 30-32 - Lower Ball Joint Remover in Place

**CAUTION:** Ball joint may pop out suddenly.

#### c. Lower Ball Joint Installation

1. Position ball joint in lower control arm and install Tool J-9519 as shown in Figure 30-34. Purging nipple in ball joint grease seal must be located in the extreme inboard location.

2. With a suitable socket and handle force the ball joint into the lower control arm until it is fully seated as shown in Figure 30-35.

3. Turn the stud so the cotter pin hole is fore and aft. Knuckle should be in a straight-ahead wheel position. Stud and knuckle hole must be free of dirt before assembly.

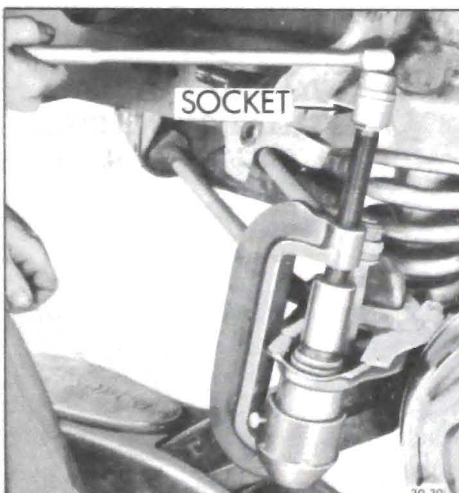

Figure 30-33 - Removing Lower Ball Joint

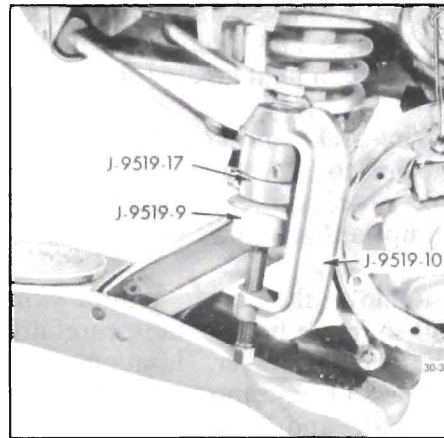

Figure 30-34 - Lower Ball Joint Installer in Place

4. Position the tapered stud in the knuckle and install castellated nut. Tighten the nut to 85 lb.ft. **Warning:** Never loosen nut to align cotter pin holes. Always tighten nut to next slot that lines up with hole. Install new cotter pin.

5. Install wheel with hub and drum assembly. Adjust wheel bearing (Group 100). Remove car stand and lower car.

#### d. Removal and Installation of Steering Knuckle

1. Follow Steps 1 through 4 of subparagraph b, Removal of the Lower Ball Joint. Be certain to merely loosen the nut.

2. Remove cotter pin and loosen (Do Not Remove) nut on upper ball joint tapered stud. Nut should be loosened not more than 1/8".

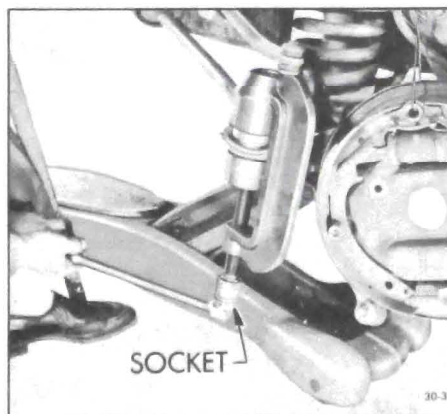

Figure 30-35 - Installing Lower Ball Joint

3. Rap steering knuckle in area of stud on both upper and lower ball joints to separate studs from knuckle. Nuts that were previously loosened still hold upper and lower control arms to knuckle and are under considerable load.

4. Make certain that the lower control arm is adequately supported by a jack on its outer extremities to prevent any downward travel of the lower control arm when removing ball joint nut (it may be necessary to actually raise the lower control arm slightly to remove force of the knuckle against the nut). Remove the nut and raise knuckle off tapered stud.

5. The upper ball joint is already loosened from the knuckle, and with no spring force to interfere, it is now possible to remove the nut from the tapered stud and thus remove the knuckle.

6. To replace knuckle, wipe stud of upper ball joint and tapered hole in knuckle clean. Assemble to knuckle with cotter pin hole fore and aft. Steering knuckle should be in a straight-ahead wheel position. Torque nut to 35 lb.ft. **Warning:** Never loosen nut to align cotter pin holes. Always tighten nut to next slot that lines up with hole. Install new cotter pin.

7. Wipe lower ball joint stud and tapered hole in knuckle clean and assemble to knuckle as outlined in installation steps 3 through 5 subparagraph c, preceding.

### 31-3 REMOVAL AND INSTALLATION OF UPPER CONTROL ARM ASSEMBLY

#### a. Removal

1. Raise car with jack under frame. Remove wheel and tire.

2. Remove cotter pin from castellated nut on upper ball joint tapered stud.

3. Loosen, but do not remove nut.

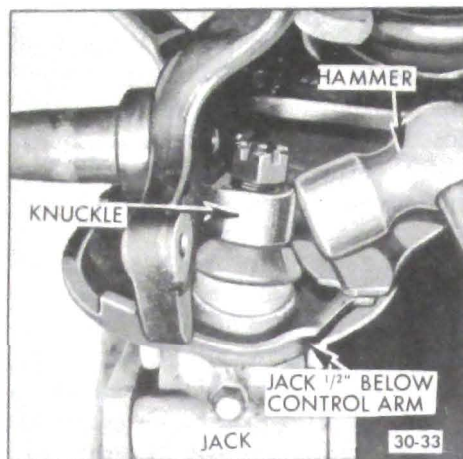

Figure 30-36 - Separating Steering Knuckle from Ball Joint

Force of chassis spring will be tending to disengage ball joint tapered stud from steering knuckle. Rap knuckle sharply in area of tapered stud to disengage stud from knuckle. See Figure 30-36.

**WARNING:** If ball stud nut is removed, injury could result since heavily compressed chassis spring will be completely released.

4. With another jack, support car weight under outer edge of lower control arm. Raise jack until com-

pression is relieved on upper control arm bumper and remove castellated nut from ball joint tapered stud.

5. Wire brake and knuckle assembly in place to prevent damage to the brake hose, and rotate upper control arm upward and away from knuckle.

6. Remove the upper control arm shaft to frame bracket nuts, carefully noting the number, location, and thickness of adjusting shims between the shaft and frame bracket. Remove the control arm assembly. Remove rebound rubber bumper from arm.

7. The upper control arm is serviced only as an assembly. Therefore, if arm is bent or distorted, bushings worn, or control arm shaft is damaged in any way, the entire assembly must be replaced.

8. Inspect stud hole in knuckle. If elongated or damaged, replace knuckle.

#### b. Installation

1. Assemble upper control arm and

shaft assembly to bracket, making certain the number, thickness and location of adjusting shims between shaft and bracket are correct. Assemble rubber rebound bumper to arm. Torque shaft to bracket nuts to 75 lb.ft. Those bolts may be torqued from within the engine compartment through the use of a standard 11/16"-1/2" drive socket and J-1313 Torque Wrench or its equivalent.

2. Make sure stud and tapered hole in knuckle are clean. Spindle should be in a straight-ahead wheel position when the stud is inserted. Assemble tapered stud to knuckle with cotter pin holes fore and aft. Install castellated nut. Torque to 35 lb.ft. *Never loosen nut to align cotter pin holes. Always tighten nut to next slot that lines up with hole.* Install new cotter pin.

3. With car at curb load, loosen upper control arm bushing to shaft bolts and bounce front end of car. Retorque bolts to 35 ft.lbs.

4. Install wheel. Check and adjust front end alignment. Adjust wheel bearings. When working in the area of the front upper control arm, make certain that the rubber water deflectors on fender skirt are securely attached in their original positions when the work is completed. If reasonable care is exercised in removing the fasteners for these rubber deflectors, they may be satisfactorily reused.

### 31-4 REMOVAL AND INSTALLATION OF LOWER CONTROL ARM ASSEMBLY

#### a. Removal

1. Remove coil spring, brake, reaction rod, and stabilizer link according to outline in paragraph 33-1.

2. Remove the lock nut and bolt attaching the control arm to the frame.

3. Remove lower control arm assembly. Remove rubber side bumper from arm.

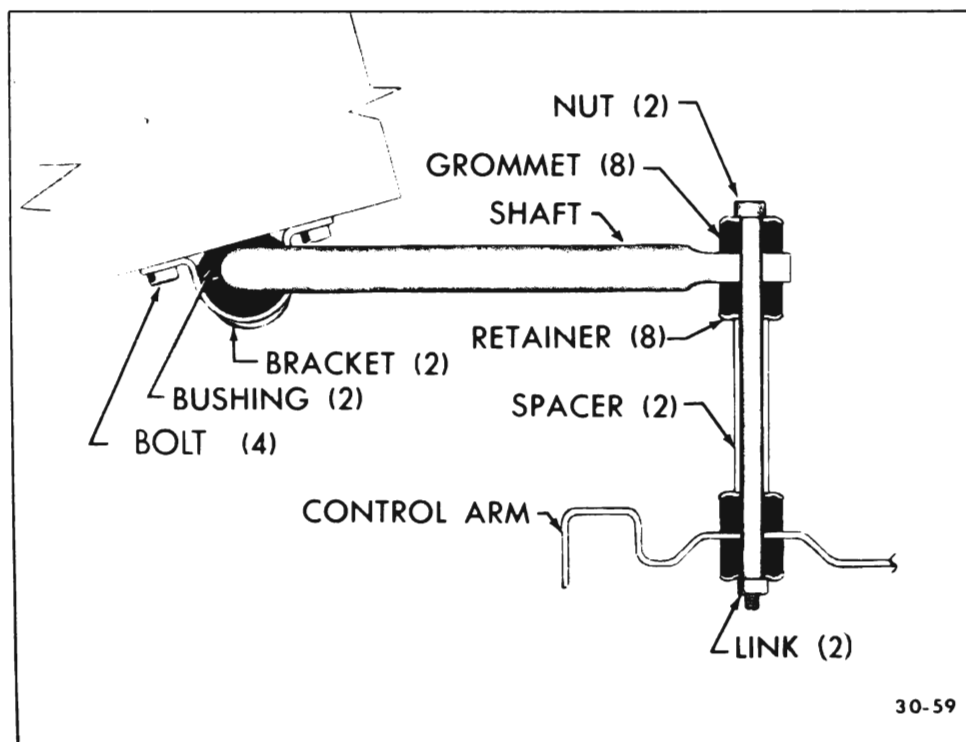

Figure 30-37 - Stabilizer Link Installation



Figure 30-38 - Right Front Coil Spring Position

#### b. Installation

1. Install new arm assembly with the arm to frame bolt head to the front of car. Install rubber side bumper to arm.
2. Reinstall coil spring, brake, reaction rod, and stabilizer link as outlined in paragraph 33-1.
3. With the car at curb load, tighten control arm attaching bolt nut to 100 lb.ft.
4. Check and adjust front end alignment.

### 33-1 REMOVAL AND INSTALLATION OF FRONT SPRING

#### a. Removal

1. Raise front of car and support solidly with a car stand under the frame side rail on the side where the spring removal is to be performed.



Figure 30-38A - Left Front Coil Spring Position

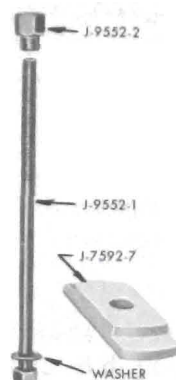

Figure 30-39 - Tool J-9552

2. Remove wheel, hub, and drum as an assembly.
3. Remove shock absorber according to outline in paragraph 36-1.
4. Remove the front stabilizer rod link from the lower control arm.
5. Disconnect brake reaction rod from lower control arm but leave attached to frame.
6. Remove control arm bumper.
7. As a safety precaution place a floor jack under the lower control

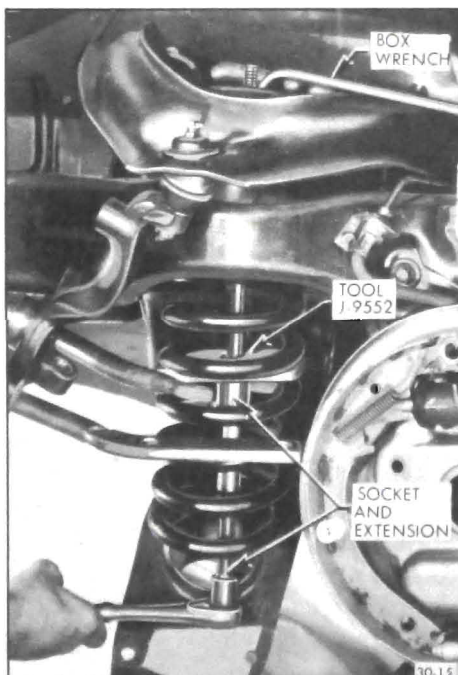

Figure 30-40 - Compressing Front Spring With Tool J-9552

arm as far outboard as possible to gain maximum leverage advantage.

Do not place the jack against the arm, but about 1/2 inch below. Now remove the cotter pin and **LOOSEN**. **DO NOT REMOVE** the nut on the lower ball joint tapered stud. The nut should be loosened not more than 1/8".

8. Rap the steering knuckle in the area of the stud to separate the stud from the knuckle. See Figure 30-36.

Raise the jack against the control arm to relieve pressure on the nut. remove the nut and separate the steering knuckle from the tapered stud.

9. Carefully lower the jack supporting the lower control arm to release the spring. With the jack all the way down to the floor it still may be necessary to pry the spring off its seat on the lower control arm with long pry bar. *Warning: Caution should be exercised in handling this preloaded spring while it is still installed in the car.* Care should be taken so the spring, when removed, does not damage the ball joint stud or seal.

10. Inspect stud and hole in knuckle. If stud is damaged or hole in knuckle is elongated, replace the necessary parts.

#### b. Installation

1. Position spring in frame upper spring seat. When assembled, the end of the lower coil must be outboard within 1/4 inch of the front face of the left arm and rear face of the right arm.

2. Place plate J-7592-7 of spring installing Tool J-9552 between the 4th and 5th coil of the spring from the bottom. Step in plate will fit contour of the coil. Install bolt to plate and place threaded end of the bolt through the shock absorber hole in the frame spring seat.

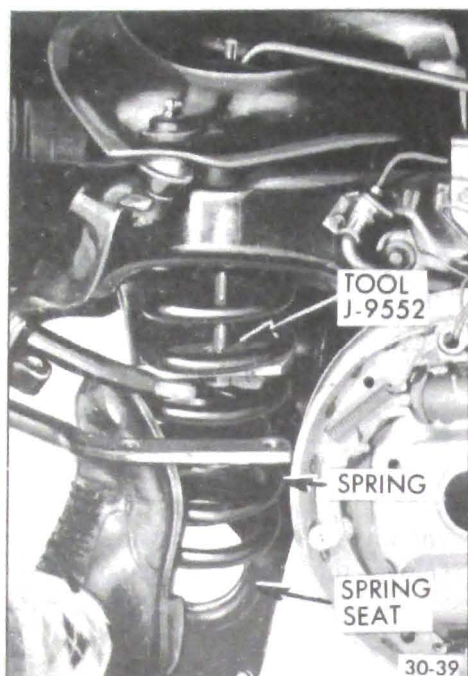

Figure 30-41 - Pushing Spring Onto Lower Control Arm Seat

3. Install special nut J-9552-2 on the upper end of the bolt so that the shoulder of the nut protrudes through the hole in the upper spring seat to protect the threads of the bolt at this point.

4. Place a box wrench on the upper nut of the tool to keep it from turning. Now tighten the bolt with a 7/8" socket and extension. See Figure 30-40.

5. Tighten the bolt, compressing the spring, until at least 1-3/4" to 2" of the rod protrudes through the upper nut of the tool. At this point the spring is usually compressed sufficiently to allow easy installation on the lower control arm.

6. Force the spring on its seat in the lower control arm as shown in Figure 30-41. Remove tool. Rotate spring on arm until it is seated properly.

7. Make sure stud and tapered hole in knuckle are clean. Spindle should be in a straight-ahead wheel position when the stud is inserted. The cotter pin hole in the lower ball joint stud should be located fore and aft. With the spring in position raise the

lower control arm with the jack and attach the lower ball joint tapered stud to the knuckle. Make certain that the rubber dust cover is in place on the ball joint. Torque the stud castellated nut to 85 lb.ft. *Warning: Never loosen nut to align cotter pin holes. Always tighten nut to next slot that lines up with holes.* Install a new cotter pin.

8. Install shock absorber. Torque upper nut to 10 lb.ft. and lower bolt nut, to 35 lb.ft.

9. Attach brake reaction rod and compression bumper to the lower control arm. Torque the nuts to 55 lb.ft.

**NOTE: Never use standard bolts, nuts or washers at this location. If replacement parts are needed a package, (Group 6.171), contains the two special nuts and two special washers necessary for this installation.**

10. Reinstall stabilizer link and grommets. See Figure 30-37.

11. Replace wheel hub and drum assembly. Readjust wheel bearings.

12. Remove the car stand and recheck and adjust toe-in as necessary.

### 36-1 SHOCK ABSORBER SERVICE

#### a. Removal

1. Remove upper shock absorber attaching nut, grommet retainer and grommet.

2. Remove the lower retaining bolt and nut. Lower shock through hole in lower control arm.

#### c. Installation

1. Select the correct, shock absorber for particular car model. Refer to Master Chassis Parts Catalog for correct absorber. Substitution of an incorrectly calibrated shock absorber will adversely affect car handling performance.

2. Assemble lower grommet retainer and grommet on shock stem. Extend

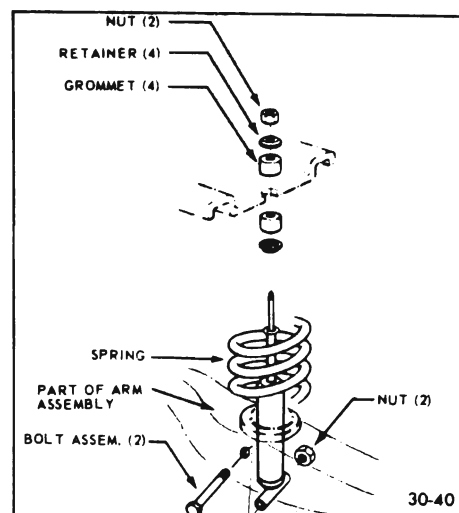

Figure 30-42 - Shock Absorber Mounting Details

shock and install through lower control arm. With shock upright in vise, push and pull shock rod through its full travel several times to pump out any air which might be trapped in the inner cylinder. Keep shocks upright until installed. It is a good idea to replace the shock absorber rubber grommets whenever a shock is removed or replaced.

3. Install shock, lower attaching bolt and nut. Torque to 35 lb.ft.

4. Assemble top grommet, grommet retainer, and nut on stem. Torque to 8 lb.ft.

### 37-1 REMOVAL AND INSTALLATION OF STABILIZER BAR

#### a. Stabilizer Shaft, Removal and Replacement

Disconnect stabilizer links (subpar. c following) and disconnect the two frame-to-shaft insulator mounts and brackets.

To install, position insulator mounts and brackets over shaft and connect bracket to frame.

Torque bracket bolts to 20 lb.ft. Connect stabilizer links subparagraph c below. Do *not* lubricate insulator mounts.

**b. Stabilizer Bracket and Insulator, Removal and Replacement**

Stabilizer brackets should be replaced if damaged, and rubber insulator mounts replaced if deteriorated.

Replace by supporting stabilizer shaft in position and replacing brackets and mounts one at a time. Torque bracket bolts to 20 lb.ft.

**c. Stabilizer Link Removal and Replacement**

1. Remove nut from lower end of link. Remove link, spacer, retainers and grommets. See Figure 30-37.

2. Inspect link and grommets.

3. Install grommets dry and use care to center the grommets in the seats on stabilizer shaft and hole in brake reaction rod. Also, center the retainers on grommets before tightening link nut.

4. Tighten link nut to 8 lb.ft.

**37-2 REMOVAL AND INSTALLATION OF BRAKE REACTION RODS****a. Removal**

1. Raise front of car.

2. Remove nut, washer, and front rubber bushing at frame attachment.

3. Remove two bolts, nuts and washers at lower control arm, remove nut at bottom of stabilizer link and raise link upward. Slide reaction rod out of hole in frame.

4. Remove rear washer and rear rubber bushing.

**b. Installation**

1. Remove and replace old rubber bushings if worn.

2. Install washer with largest hole on brake reaction rod first, with concave side toward control arm. Install rear bushing on rod with tapered end of bushing pointing forward.

Insert rod and rear bushing through hole in frame bracket. Install front bushing on rod with concave side of bushing next to the frame. Install washer with smaller hole on end of rod and with concave side toward bushings. Start nut, but do not tighten. Do not lubricate bushings.

3. Install two attaching nuts, bolts, and washers to lower control arm. Torque nuts to 55 lb.ft.

4. Reposition stabilizer link; install lower grommet, retainer and nut; and torque to 8 lb.ft.

5. Torque nut at frame end of brake reaction rod to 80 lb.ft.

**NOTE: CASTER AND CAMBER MUST BE CHECKED AFTER REPLACEMENT OF BRAKE REACTION ROD.**

**NOTE: If there is any question concerning the serviceability of the brake reaction rod to lower control arm bolts, nuts or washers, install Group 6.171, which includes two special bolts, two special nuts, and four special washers. Never use standard bolts, nuts, or washers at this location.**

**DIVISION IV****TROUBLE DIAGNOSIS****37-3 FAULTY SPRINGS, SHOCK ABSORBERS, AND BALL JOINTS****a. Trim Height Checking Considerations**

Optional equipment, undercoating, accumulated dirt, etc., change the car weight and must be considered when checking spring trim dimensions. Because of the many possible variations in loading due to optional equipment, it is not possible to give dimensions for all conditions; therefore, the spring trim dimensions following are for the standard car only, without optional equipment or undercoating and with car at curb weight. Curb weight includes a full tank of gas, oil, water, and spare tire but no passengers.

Before measuring spring trim dimensions, bounce both ends of the car up and down several times to make sure there is no bind in suspension members, and to let springs take a natural position.

**b. Measuring Trim Height**

1. On a new car, the *front* spring trim dimension "K" should be as shown in Figure 30-30.

**NOTE: On a car having service miles the trim height may be less due to normal settling of bushings, dirt accumulation, etc.**

2. On a new car, the *rear* spring trim dimension "L" should be as shown in Figure 30-30.

**NOTE: on a car having service miles the trim height may be less due to normal settling of bushings, dirt accumulation, etc.**

3. When checking *side to side* differences in trim height at the *front* take measurements at the front rocker panel as shown in Figure 40-7.

**NOTE: A maximum of three (3) front shims may be installed on top of the front spring with a change in trim height double the thickness of the shims. This will provide for a maximum correction at the fender of .75 inch. A maximum of two (2) rear shims may be installed between the rear spring and the spring seat on the axle with a change in trim height the same as the thickness of the shims. This will provide for a maximum correction at the fender of .24 inch. Cars with 1 inch tilt right to left cannot be corrected by shims. In most of these cases with the left side high, right side low, the tilt can be corrected by swapping the front springs right to left and left to right. The Electra front springs have a higher rate than the LeSabre or Wildcat and thus shims in addition to swapping are required to correct for a 1 inch tilt. If side to side variation is in excess of one inch, check suspension components for damage, excessive wear, or incorrect spring installation. See subpara-**

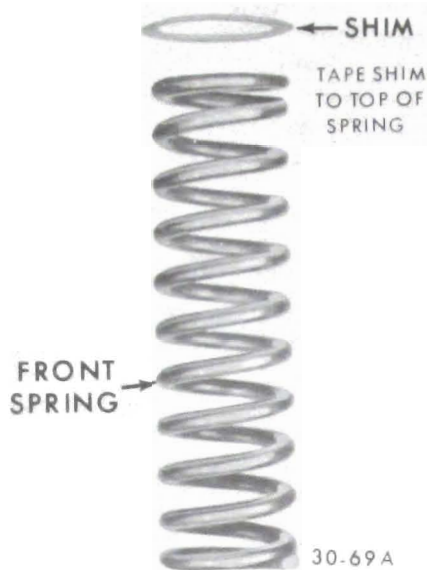

Figure 30-44 - Installing Shim on Spring

graph c following for front shim installation.

4. When checking side to side differences in trim height at the rear take measurements at the rear rocker panel as shown in Figure 40-7. If shimming is required, see subparagraph c following.

#### c. Installation of Front Spring Shim

To correct variations in trim height, front spring shims may be ordered from the Parts Department under Group 7.425.

1. Remove front spring from car as described in paragraph 33-1.
2. Place shim at top of spring as shown in Figure 30-44. Taping shim to spring will aid installation.
3. Install shimmed spring in car per paragraph 33-1.

#### d. Weak and Non-Operative Shock Absorbers

Many shock absorbers have been replaced and returned to the factory with the report that they were weak or leaking oil. When tested with special factory equipment very few of these replaced units have been found weak, leaking oil, or otherwise below standard in operation. This

indicates that these shock absorbers were needlessly replaced in an attempt to improve riding conditions which were actually standard, or that erroneous methods were used in judging the operating condition of the units.

Leaking shocks should not be diagnosed by observing a light oil film on or around the shock.

The shock absorber seal is designed to allow for lubrication of the piston rod, which under normal conditions, causes a light oil film to accumulate on the shock. This does not affect shock operation nor is replacement necessary as *all Delco shocks contain an added fluid reserve for this purpose.*

A leaking shock absorber is easily spotted as there will be evidence of fluid droplets on or around the shock. Before replacing any shock absorber, verify that the oil present on the shocks is not from some other chassis component.

Before attempting to test shock absorbers make sure that all attaching bolts and nuts are tight. Tires should be uniformly inflated to specified pressure (Group 100). The chassis should be well lubricated to make sure that suspension parts are free moving.

Test each front and rear shock absorber in turn by quickly pushing down and then lifting up on the end of the car bumper closest to the unit being checked. Use the same amount of force on each test, and note the amount of resistance provided by the shock absorber on compression and rebound. A little practice on another car of the same model which has satisfactory ride control will aid in judging the amount of resistance that should exist. Both front shock absorbers should provide the same feeling of resistance as should both rear shock absorbers. Any noticeable variation between right and left shock absorbers indicates that one unit is not operating normally. Little or no resistance on compression or re-

bound indicates air in the shock absorbers, internal leakage due to wear, or that the valve is held open by dirt. Excessive resistance indicates that the bleeder holes in the valve are plugged with dirt.

If there is any doubt about the action of a shock absorber after testing as described above, remove the unit from car. Mount it vertically in a vise with the jaws gripping the lower mounting firmly, then move the piston rod up and down by hand. There should be no free movement in this test. Lack of resistance or jerky resistance to movement indicates air in the shock absorber, internal leakage due to wear, or that the valve is held open by dirt. A faulty shock absorber must be replaced as it cannot be disassembled for repairs. In the test given above, the amount of force that can be applied is not sufficient to open a valve against its spring pressure; therefore, this test only checks the flow of fluid through the valve bleeder hole as well as any leakage due to a valve being held open, or due to internal wear of piston and cylinder. Since it is unlikely that the valve springs will weaken in service, it may be assumed that the shock absorber action is normal, if it operates satisfactorily in the test given above.

#### e. Loose Ball Joints

The upper ball stud is spring equipped and thus preloaded in its socket at all times. This minimizes looseness at this point and compensates for normal wear. If the upper stud has any perceptible lateral shake, or if it can be twisted in its socket with the fingers, the upper ball joint should be replaced.

The lower ball joint is not spring loaded but is held seated by the weight of the car. With the chassis from the ball joint, this ball joint may show looseness. Such looseness is probably due to normal operating clearance.

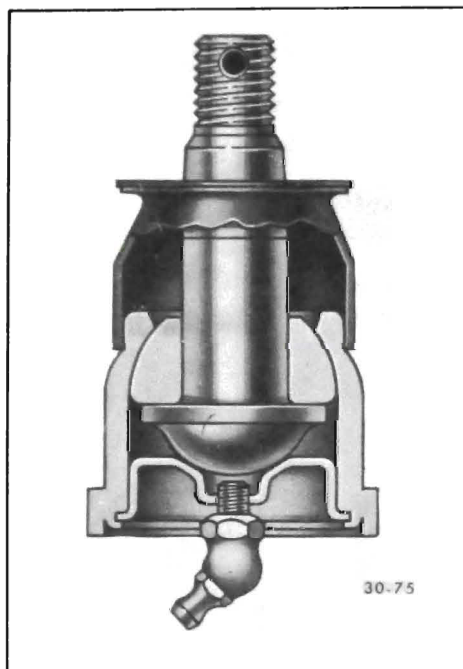

Figure 30-45 - Lower Ball Joint Construction

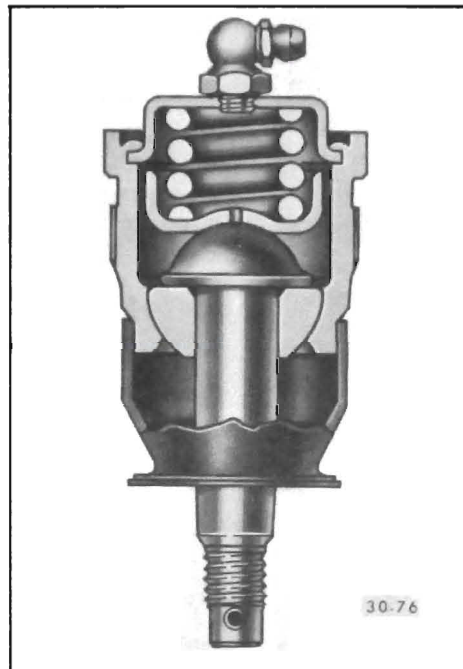

Figure 30-46 - Upper Ball Joint Construction

1. Place jack under lower control arm as far outboard as possible and still have access to the lower ball joint grease fitting. *Be sure the upper control arm does not contact the rebound bumper when the car is raised.* Raise car until front wheel clears the floor.

2. Remove lower ball joint grease fitting and install Gauge J-21240.

3. Place a pry bar between floor and tire and raise tire. This puts a load on the ball joint.

4. Repeat procedure several times and take maximum and minimum gauge readings under load and no load conditions.

5. Subtract minimum reading from maximum reading. If difference is more than .100", replace ball joint.

**f. Loose Upper Control Arm Bushing Retaining Bolts**

If loose upper control arm bushing retaining bolts are encountered, it is necessary to torque bolts to 55 lb.ft.

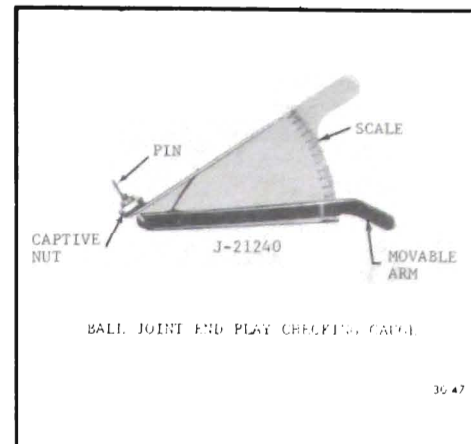

Figure 30-47 - Ball Joint Check Gauge J-21240

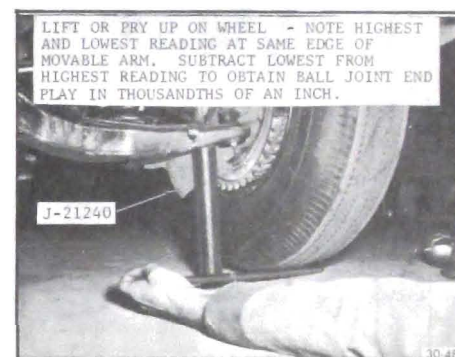
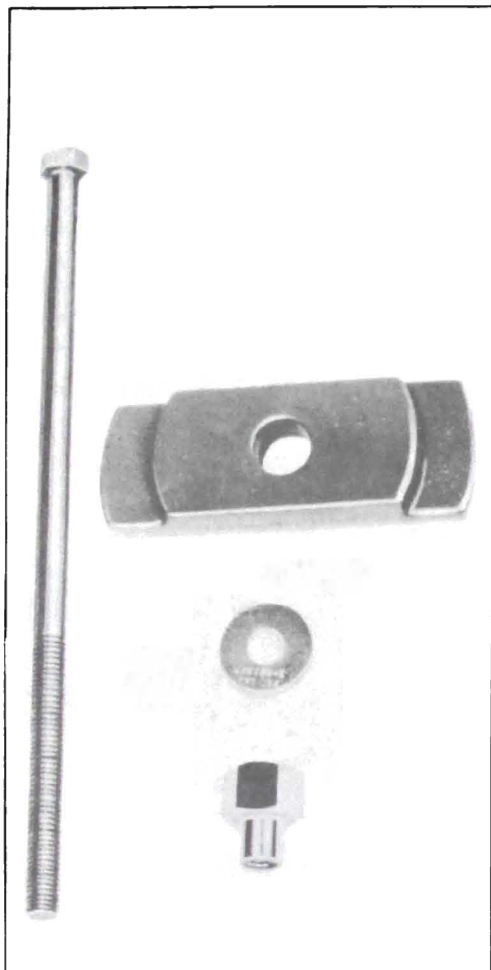

Figure 30-48 - Ball Joint Check Gauge Installed

On some cars equipped with air conditioning, power brakes, etc. it might be necessary to remove the upper control arm per paragraph 3l-3 to torque the bolts. Bolts should be tightened with the car at curb height.





J-9552



J-9519-01

- J 9519-01 LOWER CONTROL BALL JOINT REMOVER AND REPLACER SET
- J 9552 FRONT COIL SPRING COMPRESSOR