

SECTION C

49000 FRAME AND BODY MOUNTINGS

CONTENTS

Division	Subject	Paragraph
I	SPECIFICATIONS AND ADJUSTMENTS: Body Mount Specifications and Adjustments	20-9
II	DESCRIPTION AND OPERATION: Description of Body Mounts	20-10
III	SERVICE PROCEDURES: Removal and Installation of Body Mounts	20-11
IV	TROUBLE DIAGNOSIS: Trouble Diagnosis	20-12

DIVISION I

SPECIFICATIONS AND ADJUSTMENTS

20-9 BODY MOUNT SPECIFICATION AND ADJUSTMENT

See diagrams for correct installation and torque specifications.

DIVISION II

DESCRIPTION AND OPERATION

20-10 DESCRIPTION OF BODY MOUNTS

The body of the car is mounted to the chassis by means of thick rubber mounts. These mounts are specifically designed for each location to

give the maximum amount of structure rigidity while at the same time providing optimum road noise isolation. The mounting consists of a load carrying mount which rests on top of the frame side rails, a metal tube spacer which limits the amount of compression of the mount and an insulator which fits on the bottom side of the frame side rail surface. All bolt-in body mounts have a specified bolting torque.

DIVISION III

SERVICE PROCEDURES

20-11 REMOVAL AND INSTALLATION OF BODY MOUNTS

The removal of any one body mount necessitates the loosening of adjacent body mountings to permit the frame to be separated from the body.

During installation of a body mount, caution should be used to insure that the body mount is properly seated in the frame mounting hole, otherwise a direct metal to metal short circuit will result between the frame and body. The tube spacer should be in all bolt-in body mounts and the insulator and metal washer positioned to prevent the washer from contacting the frame side rail. Do not use lubricants of any kind on the rubber parts of the mounts. Proper clamping by the mount depends on clean and dry surfaces. Do not over-torque the body mount or a collapsed tube spacer or stripped bolt will result. Lubricating the bolt threads will result in a higher clamping force for the same torque setting. If the body mount bolt does not screw in smoothly, it may be necessary to run a tap through the cage nut in the body to remove foreign material. If caution is not observed, broken body mount bolts may result.

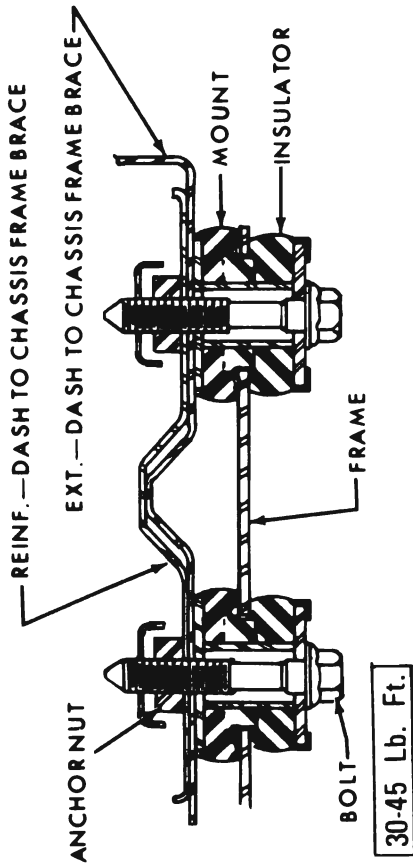

BODY BOLT NO. 1 AND NO. 1A

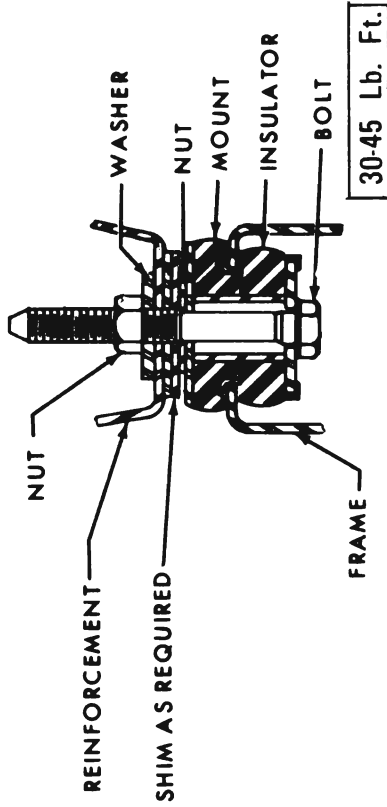

SHEET METAL MOUNT

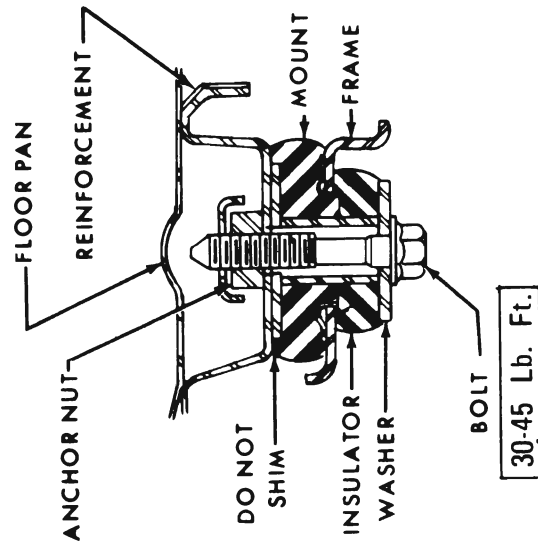

BODY BOLT NO. 4

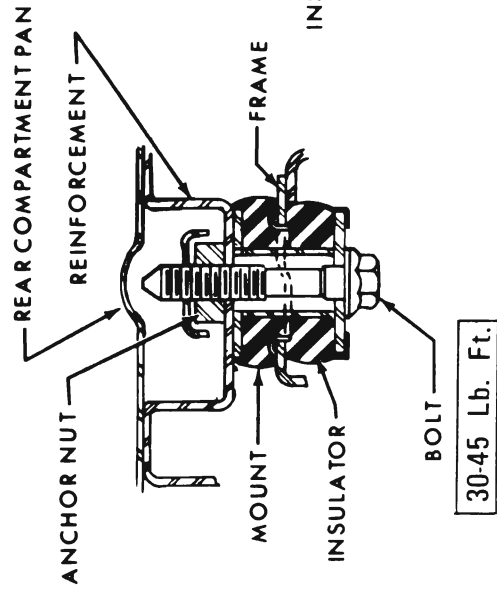

BODY BOLT NO. 5

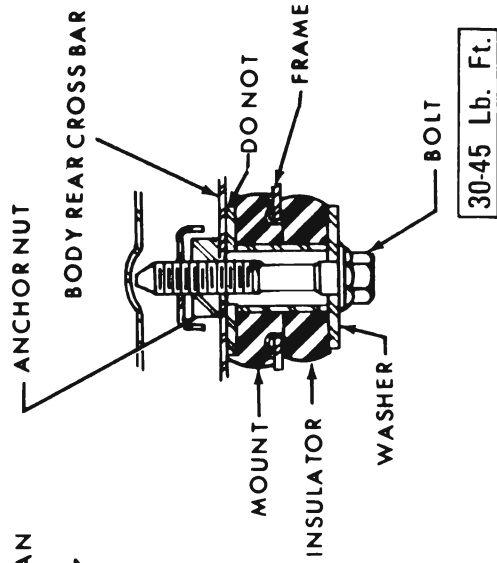

BODY BOLT NO. 6 20 - 19A

Figure 20-7 · 49000 Body Mounts

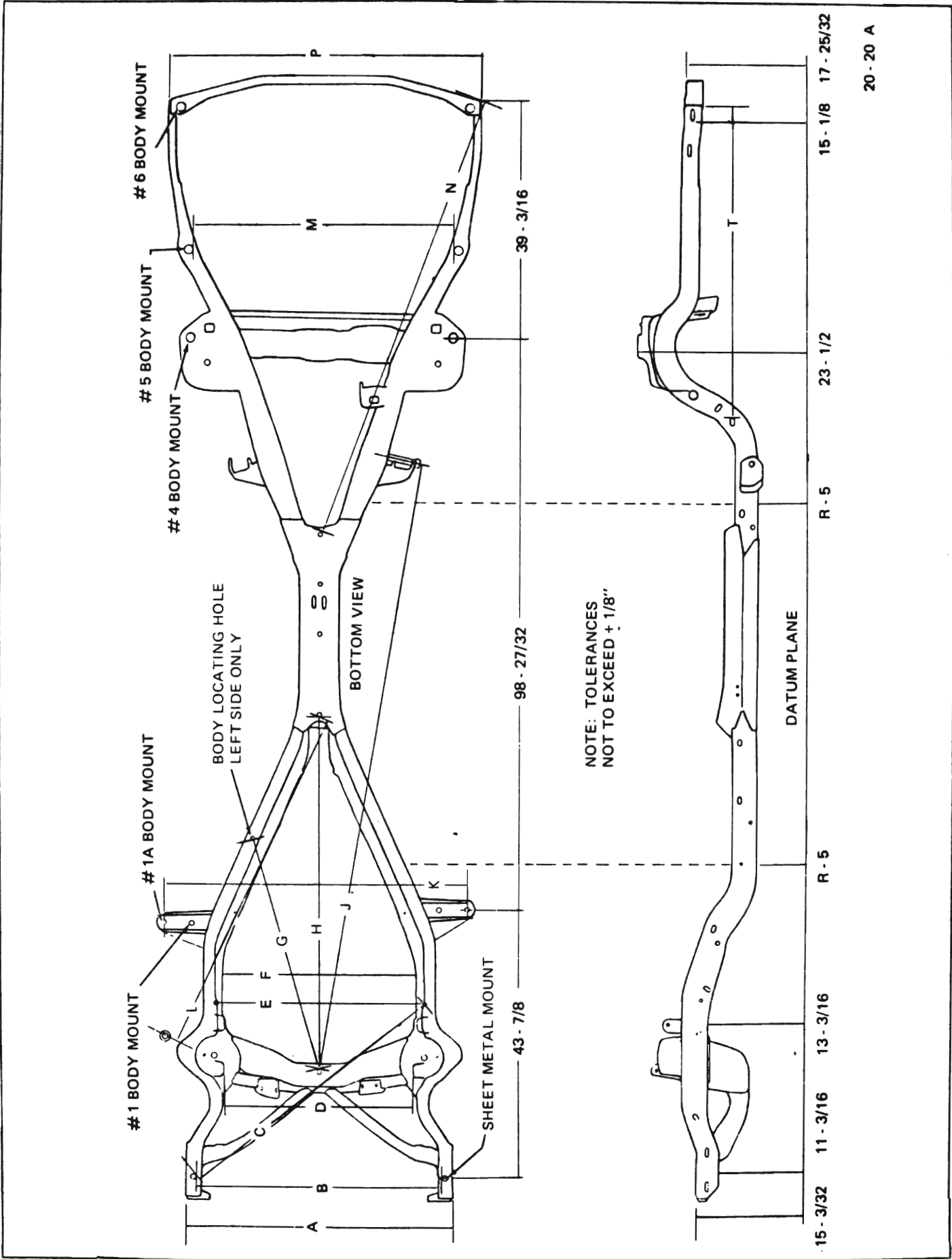

Figure 20-8 - 49000 Frame Details

RIVIERA	
A — $44\frac{3}{4}$	Outside edge to outside edge of frame.
B — $40\frac{7}{32}$	Near edge to near edge of chassis sheet metal mounting access hole.
C — $46\frac{1}{2}$	Near edge of chassis sheet metal mounting access hole to center of rivet located on bottom of frame rearward of spring.
D — $31\frac{5}{16}$	Between upper control arm support brackets (inner surface).
E — $36\frac{13}{16}$	Center of rivet head to center of rivet head.
F — $32\frac{13}{32}$	Between frame side rails at point below bottom steering gear to frame bolt and idler arm support bracket.
G — $40\frac{3}{8}$	Near edge of crossmember hole to near edge of body locating hole (left side only).
H — $61\frac{17}{32}$	Near edge of crossmember hole to near edge of forward hole at frame center.
J — $103\frac{7}{16}$	Near edge of crossmember hole to center of head of rear lower control arm pivot bolt.
K — $51\frac{1}{16}$	Center of number 1-A body mount bolt head to center of number 1-A body mount bolt head.
L — $64\frac{23}{32}$	Center of grease fitting in lower ball joint to near edge of forward hole at frame center.
M — $43\frac{5}{16}$	Near edge of number 5 body mount access hole to near edge of number 5 body mount access hole.
N — $80\frac{5}{16}$	Near edge of rearward center frame hole to outside rear corner of frame.
P — $52\frac{13}{32}$	Outside edge to outside edge of frame.
R — 5	Locations for mounting #2 and #3 datum gages. Adjust sighting pins to 5 inches below bottom of frame side rail.
S — $23\frac{1}{2}$	Bottom inner surface of spring seat (inside spring) to datum line.
T — $57\frac{5}{16}$	Near edge of horizontal slotted hole to corner of frame side rail.

DIVISION IV
TROUBLE DIAGNOSIS
20-12 TROUBLE DIAGNOSIS

Improper body mount installations

may result in the following problems:

1. Structure shake
2. Road noise

3. Squeaks

The above problems can sometimes be caused by the wrong part being installed or the mount not being properly torqued.