

SECTION H

WIRING CIRCUIT DIAGRAMS

CONTENTS

Division	Subject	Paragraph
I	SPECIFICATION AND ADJUSTMENT:	
II	DESCRIPTION AND OPERATION: Description of Circuit Diagrams and Fuse Block	120-31

DIVISION II

DESCRIPTION AND OPERATION

120-31 DESCRIPTION OF CIRCUIT DIAGRAMS AND FUSE BLOCK

This section contains pictorial and schematic wiring circuit diagrams for complete car. For more detailed *body* wiring diagrams showing the routing of the wires and the location of the switches, connectors and retaining clips - see the Fisher Body Service Manual.

A central fuse block is mounted on the cowl under the left side of the instrument panel. This fuse block serves as a convenient junction point for a number of circuits, provides a mounting for the hazard warning flasher, and contains most of the fuses.

To simplify replacement of the wiring, the circuits to the rear of the cowl are grouped in one harness and the circuits forward of the cowl are grouped in another.

The instrument panel wiring harness ends in a multiple connector which is

held in the cowl. The engine compartment wiring harnesses plug into this connector at the cowl. This type of con-

nectors aids in tracing down electrical troubles.

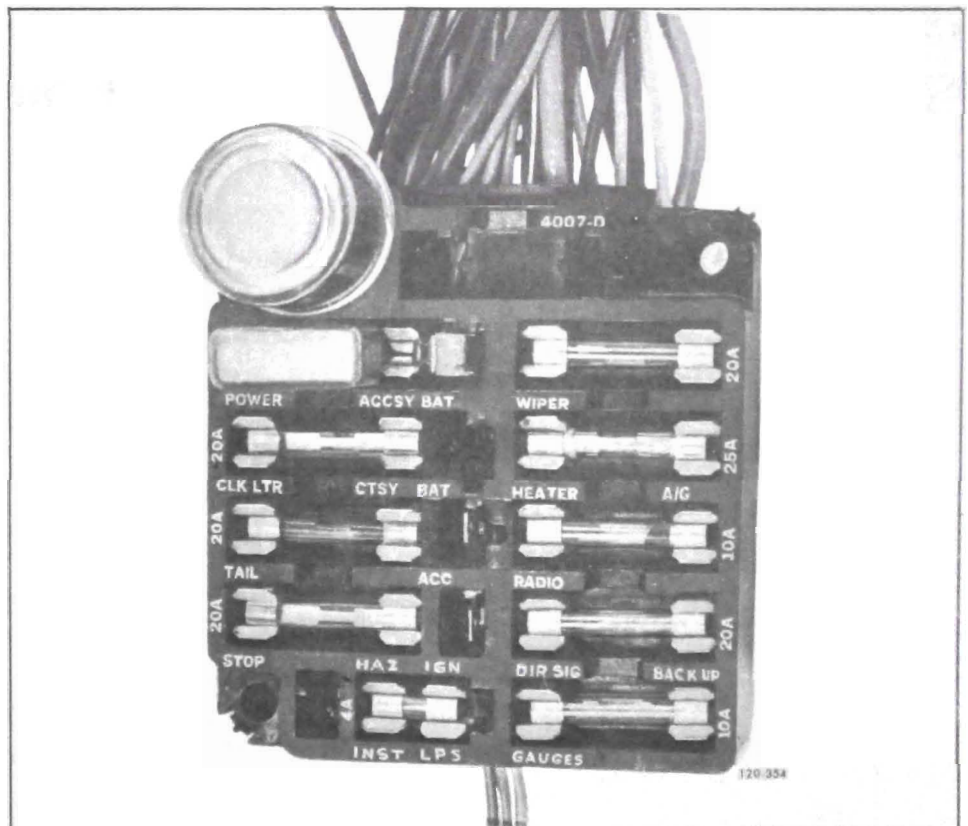

Figure I20-52 Fuse Block - All Series

a. Illustration Index

Figure 120-53 thru 69 - Chassis Electrical Wiring - 43-44000

Figure 120-70 thru 79 - Chassis Electrical Wiring - LeSabre, Wildcat and Electra

Figure 120-80 thru 87 - Chassis Electrical Wiring - Riviera

Figure 120-88 and 89 - Heater Wiring Diagrams

Figure 120-90 thru 97 - Air Conditioner Wiring Diagrams

Figure 120-98 thru 101 - Police Generator Installations

Figure 120-102 thru 105 - Power Window Wiring Diagrams

Figure 120-106 thru 108 - Power Seat Wiring Diagrams

Figure 120-109 thru 113 - Miscellaneous Wiring Diagrams

Figure 120-114 and 115 - Rear Window Defroster Wiring Diagrams

Figure 120-117 and 118 - Wiper and Transmission Wiring Diagrams

Figure 120-119 thru 121 - Horn Relay, Cruise Master Wiring Diagrams

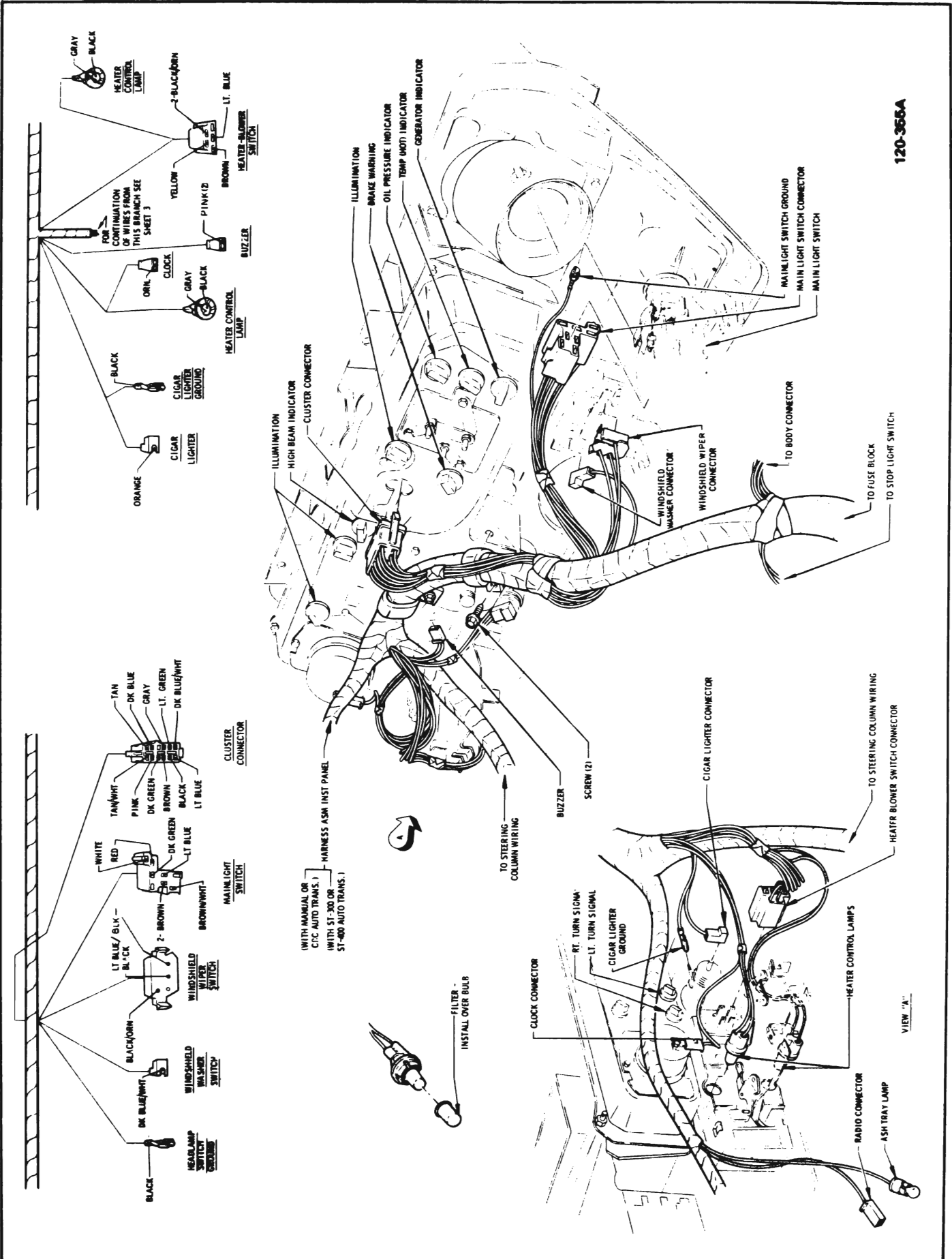
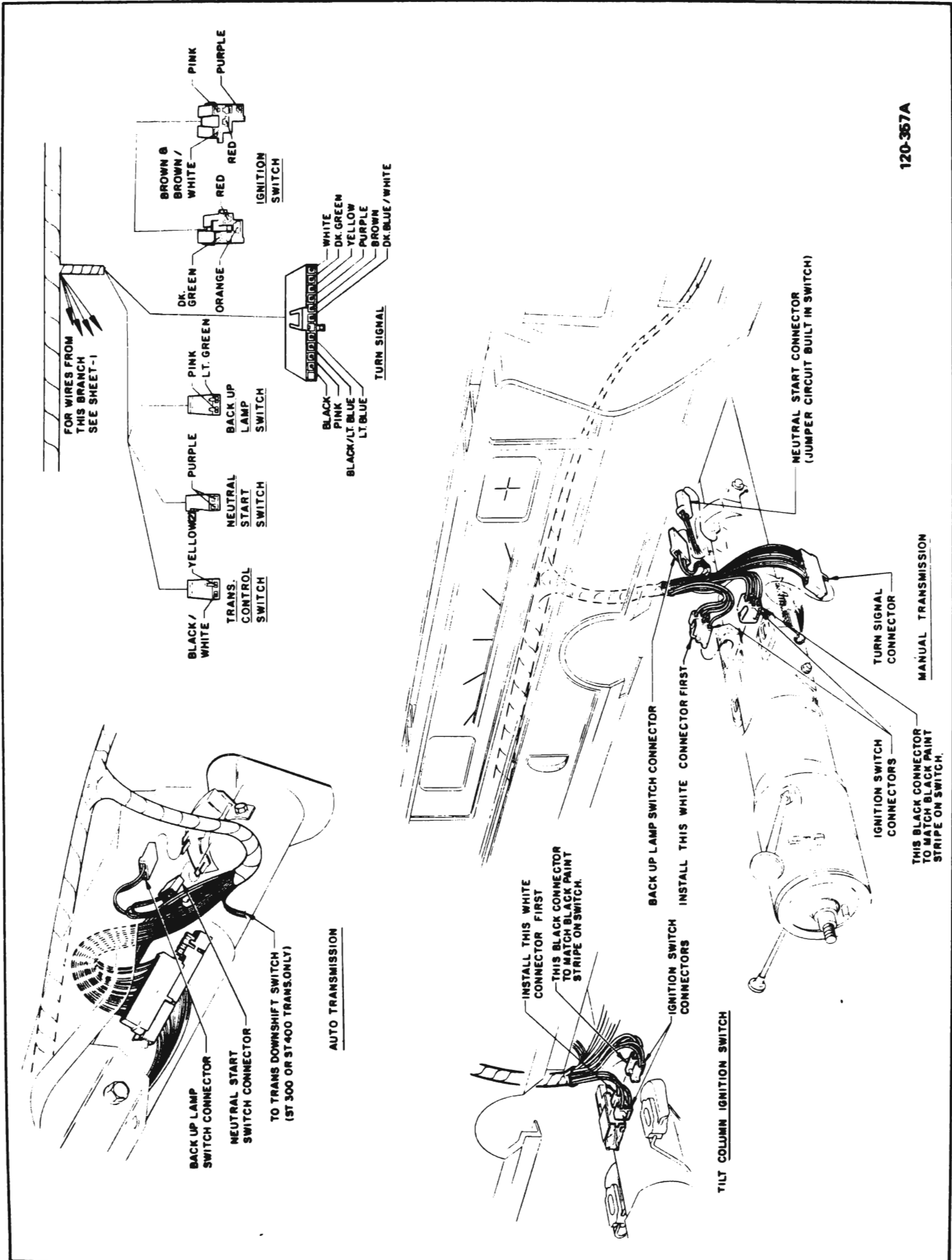

Figure 120-53 Instrument Cluster Wiring - 43-44000



120-367A

Figure 120-54 Steering Column Wiring - 43-44000

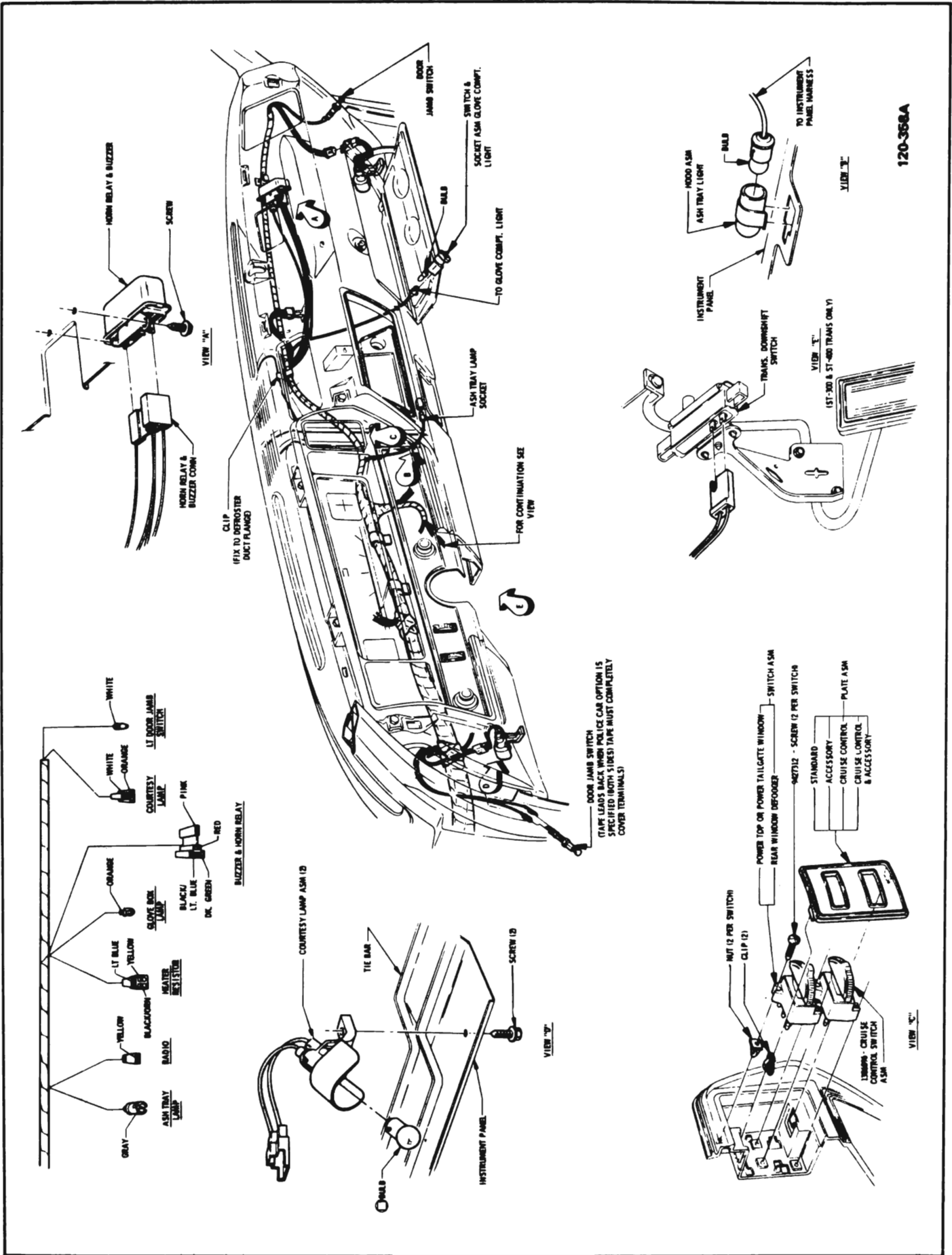
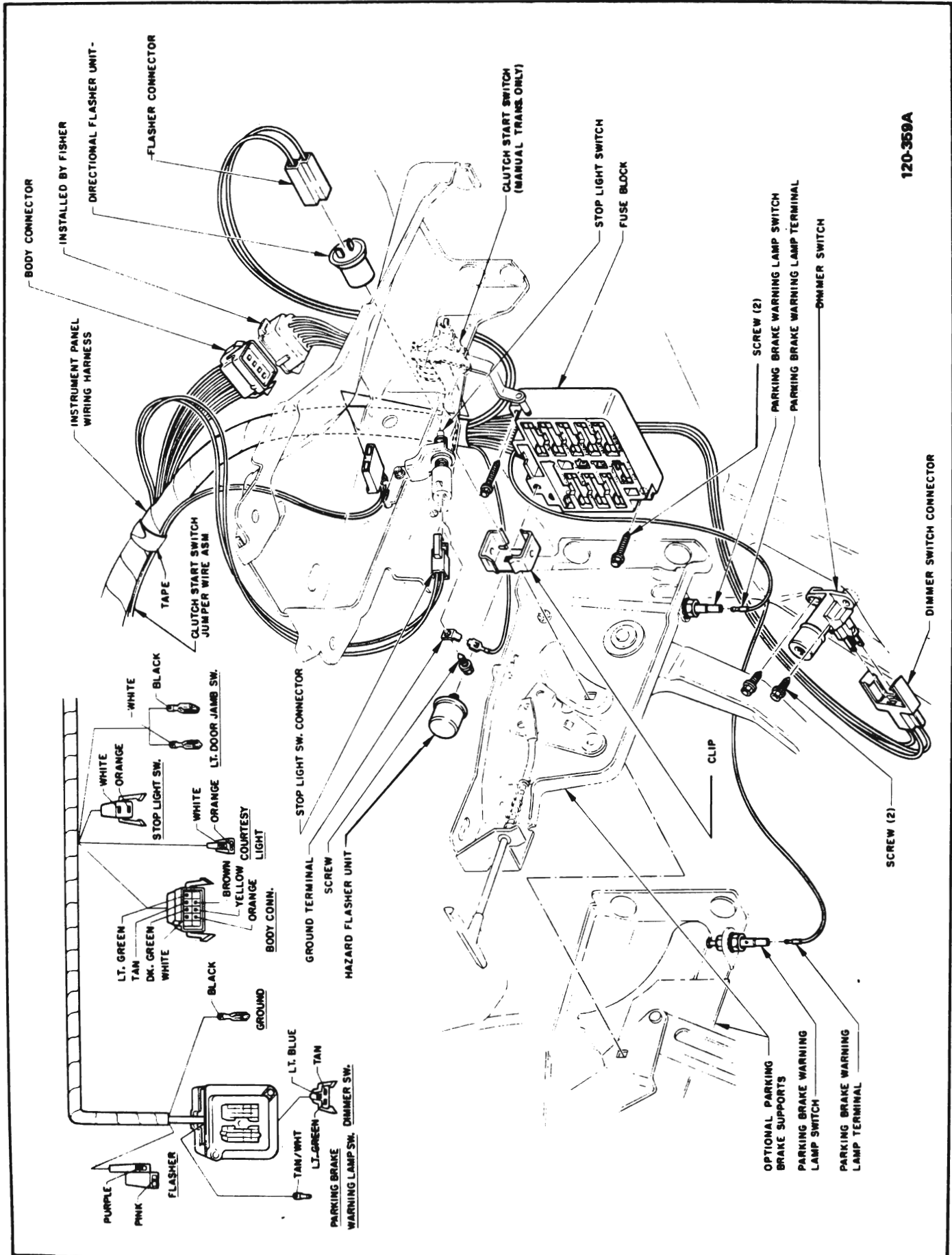

Figure 120-55 Instrument Panel Connections 43-44000



120-359A

Figure 120-56 Fuse Block Wiring
43-44000

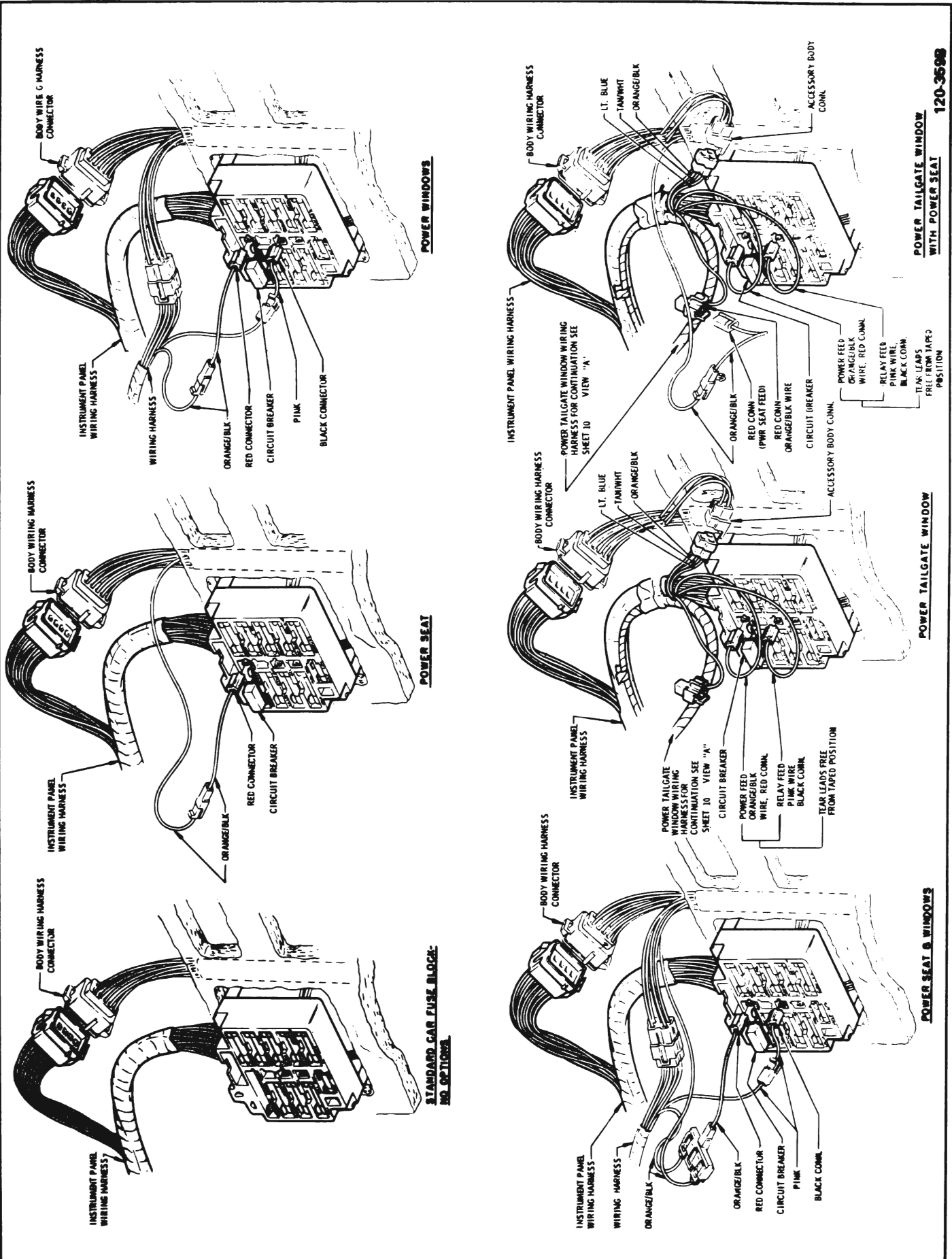

Figure 120-57 Fuse Block Wiring - 43-44000

120-3698

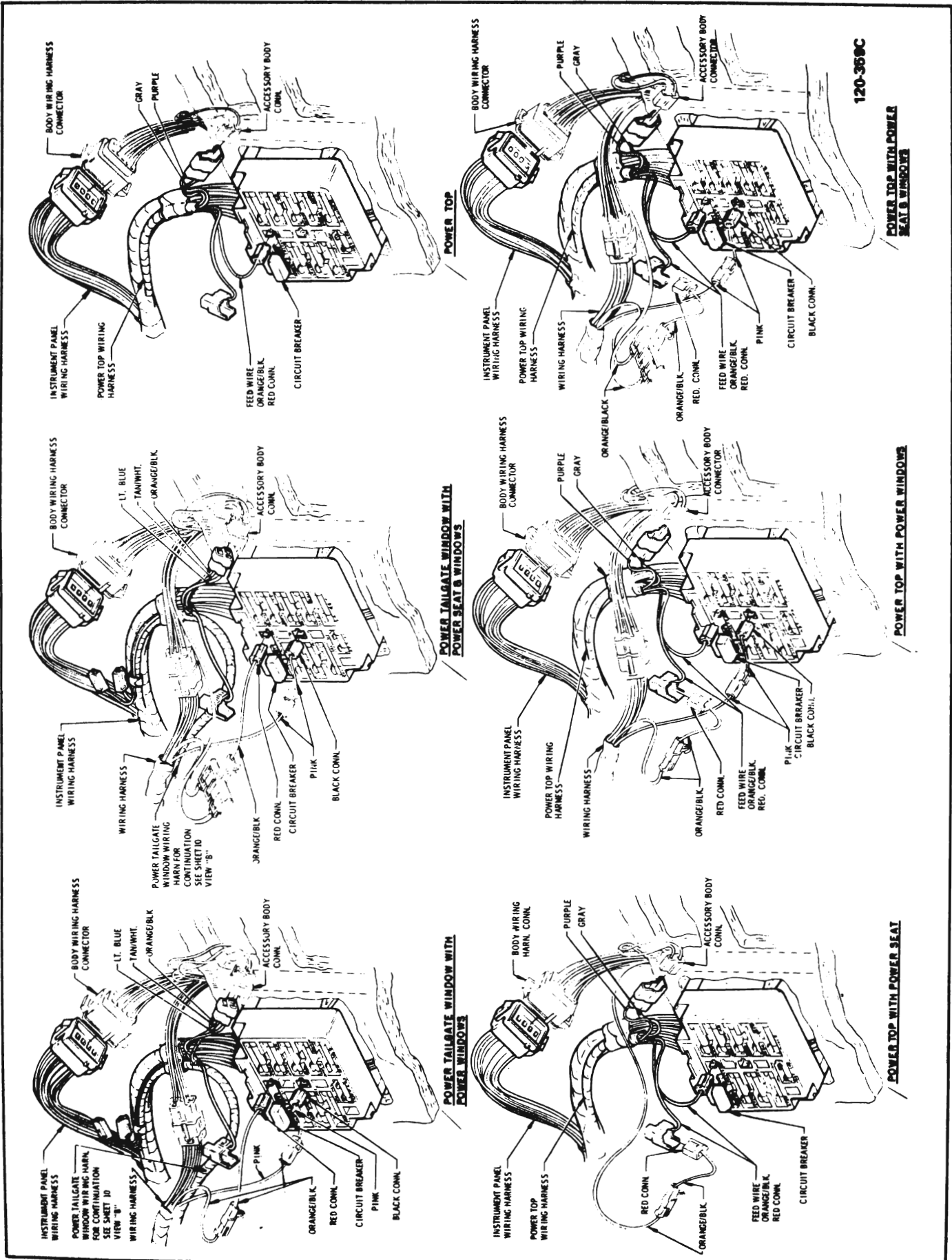

Figure 120-58 Fuse Block Wiring - 43-44000

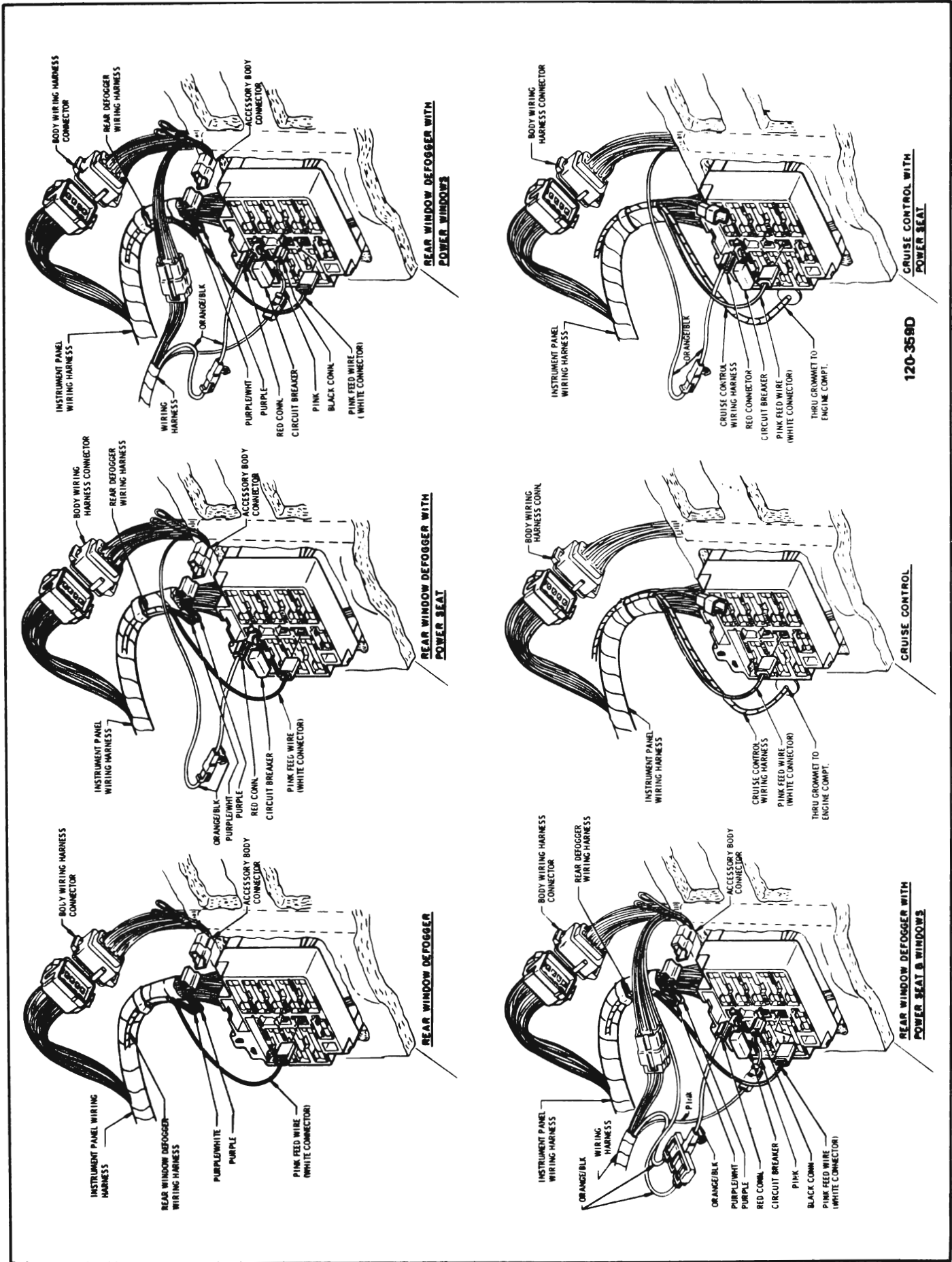

Figure 120-59 Fuse Block Wiring
43-44000

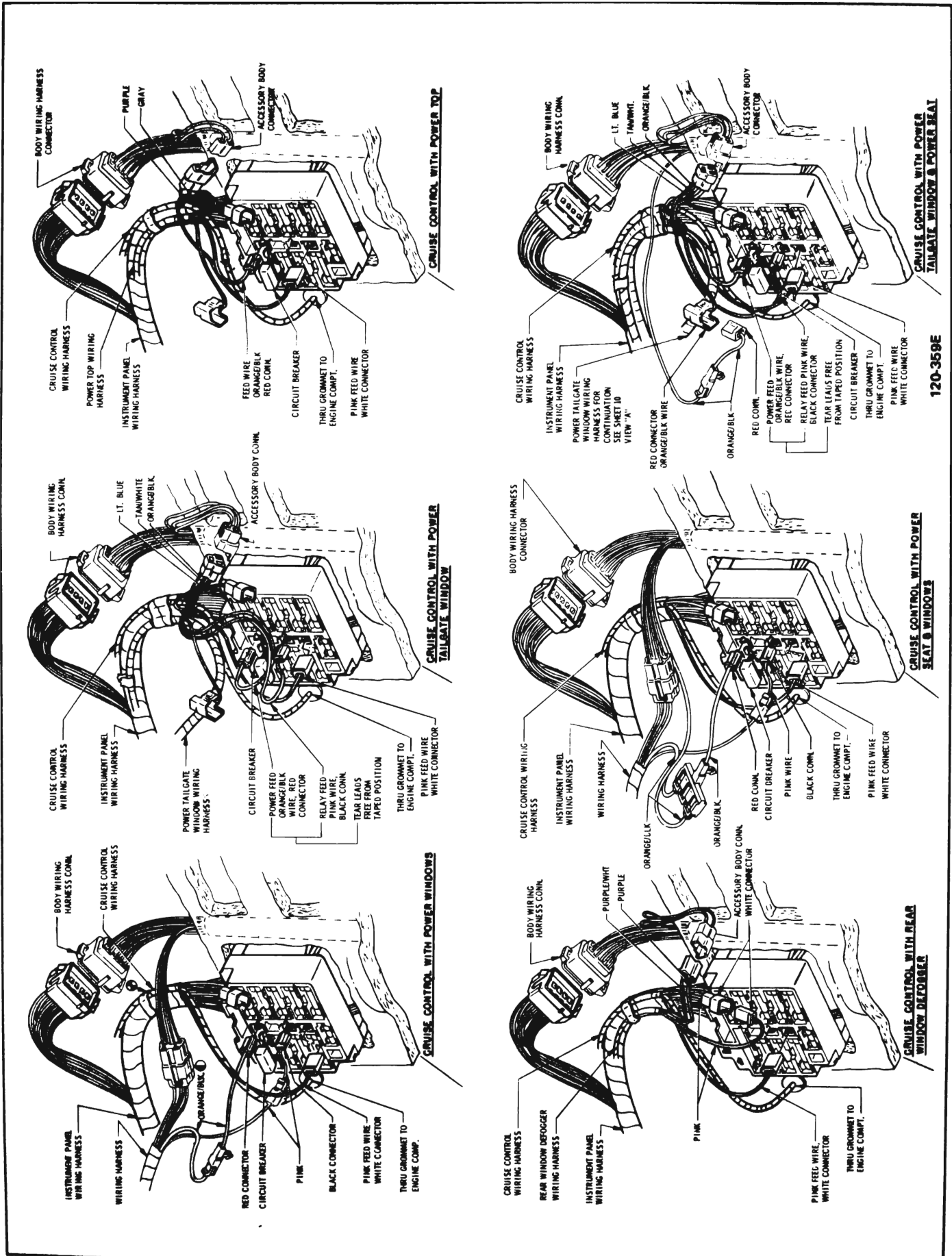

Figure 120-60 Fuse Block Wiring 43-44000

120-359E

CRUISE CONTROL WITH POWER SEAT & WINDOWS

CRUISE CONTROL WITH REAR WINDOW DEFOGGER

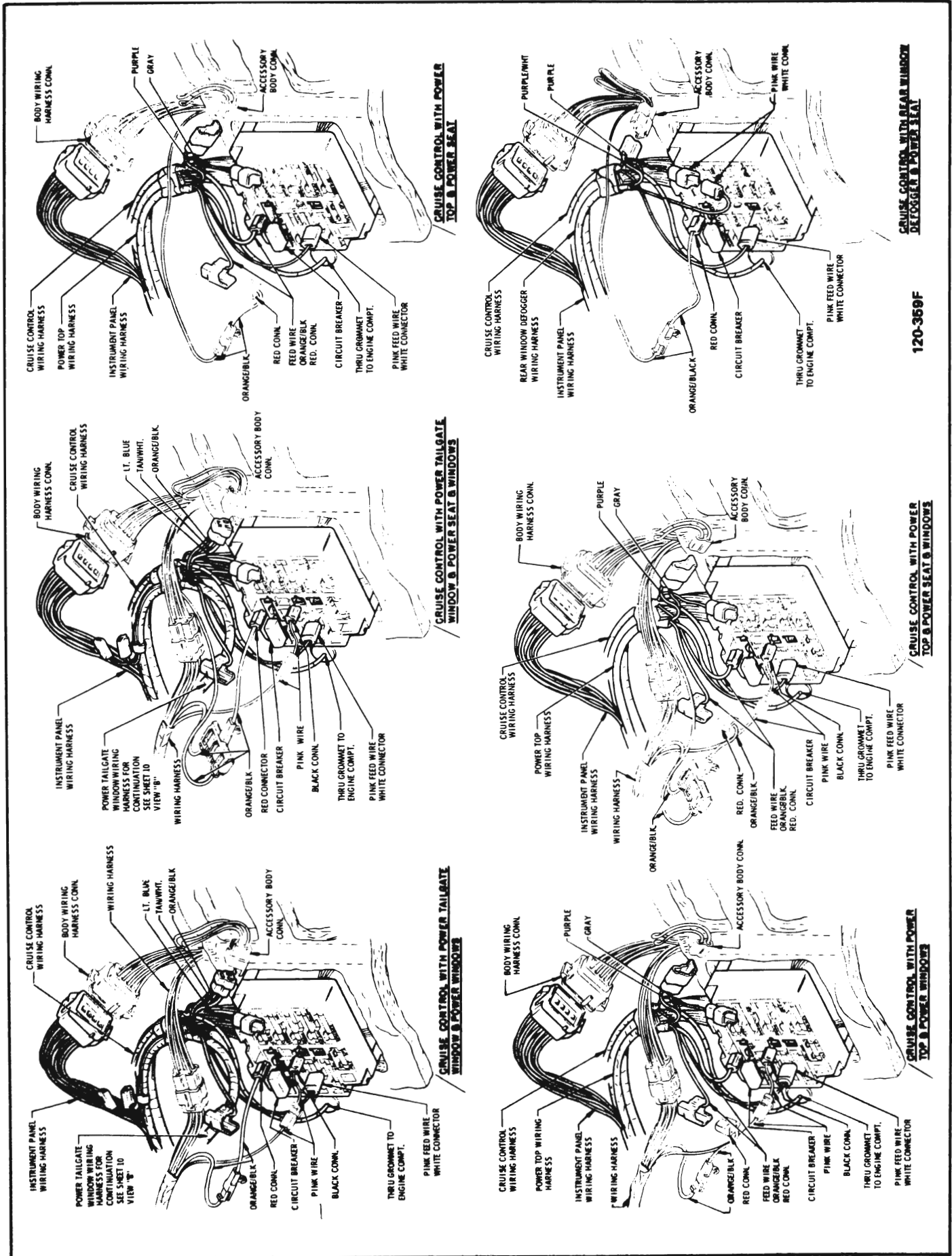

Figure 120-61 Fuse Block Wiring
43-44000

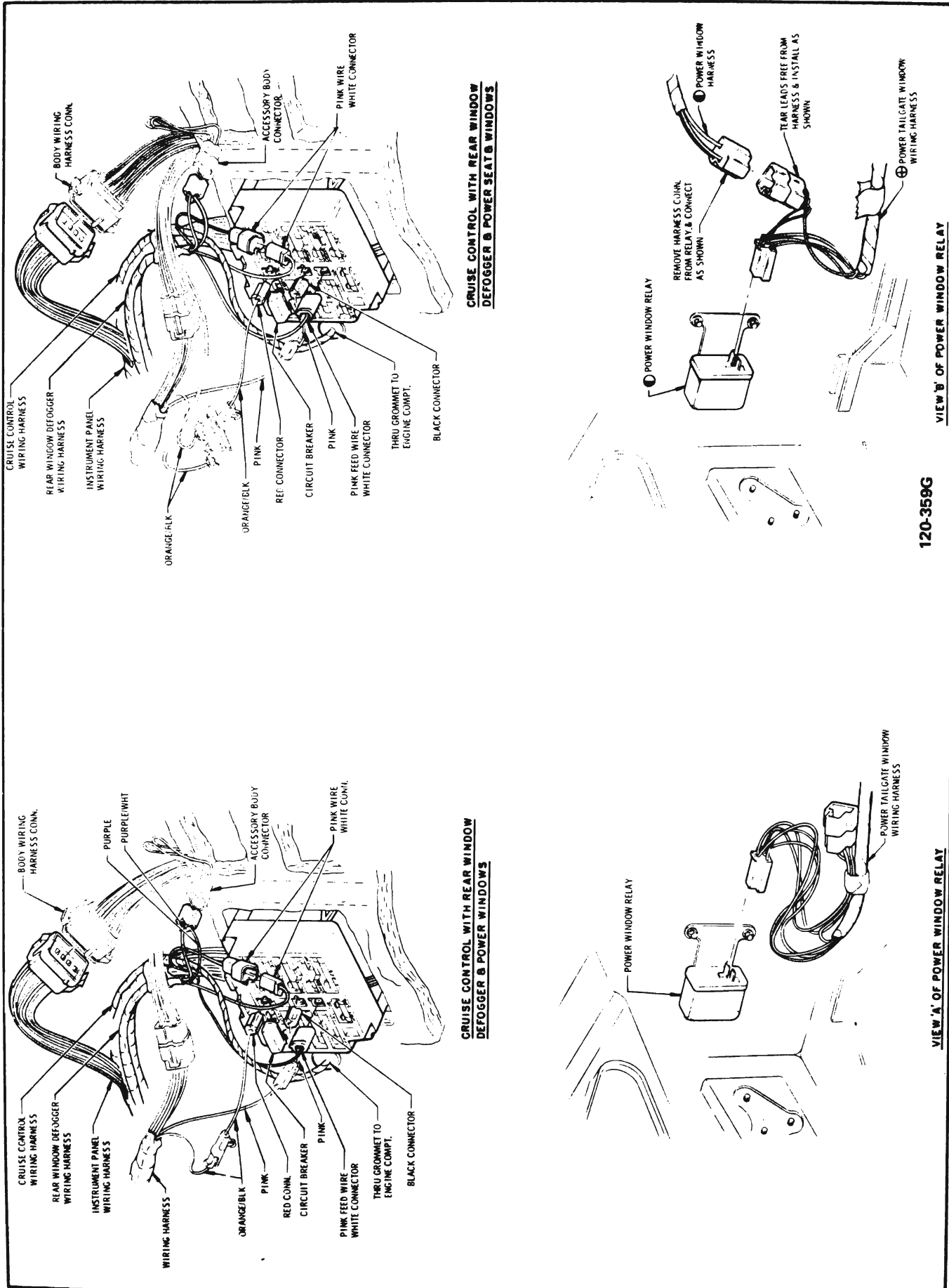
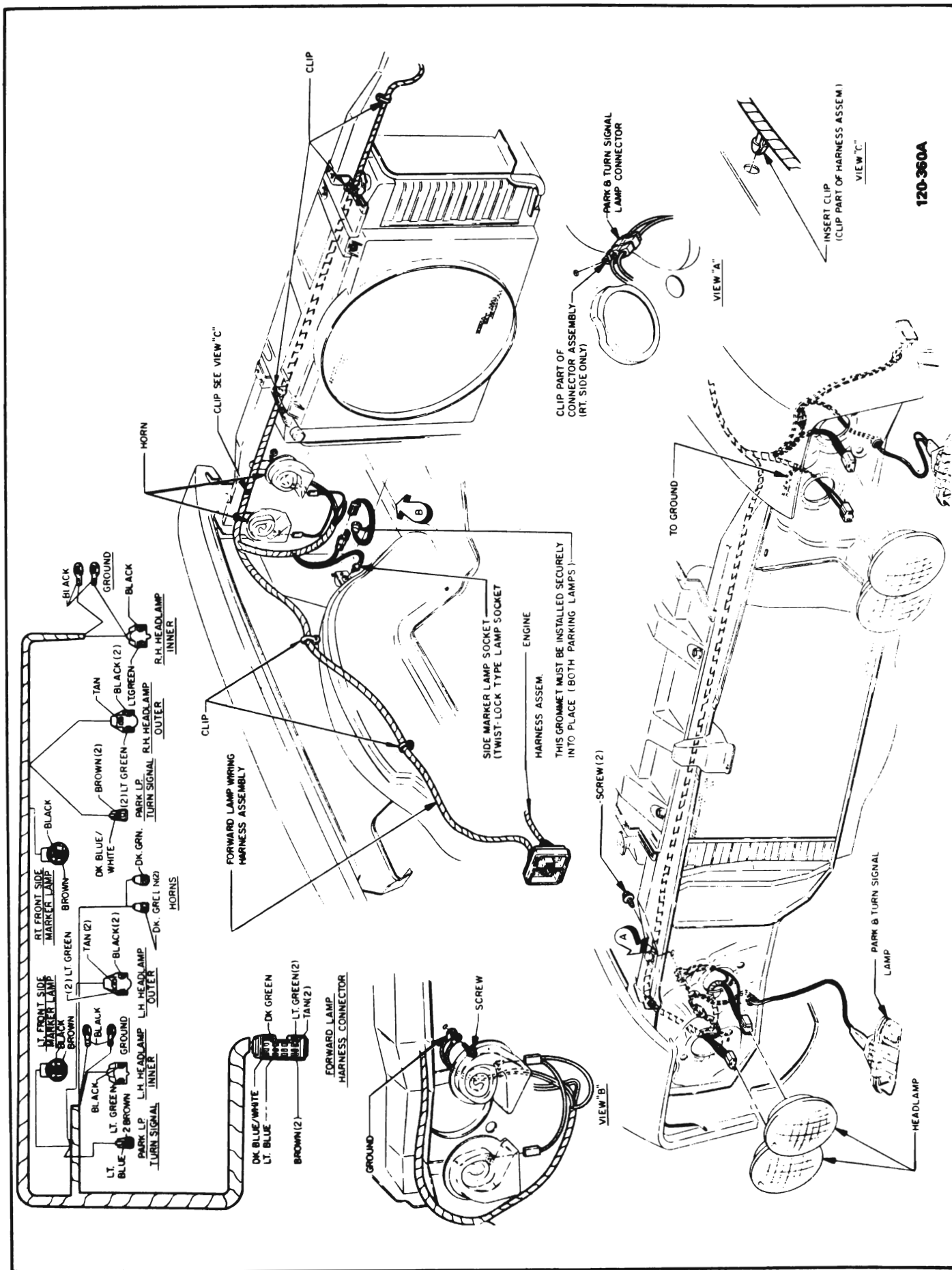

Figure 120-62 Fuse Block Wiring - 43-44000



120-360A

Figure 120-63 Forward Lamp Wiring - 43-44000

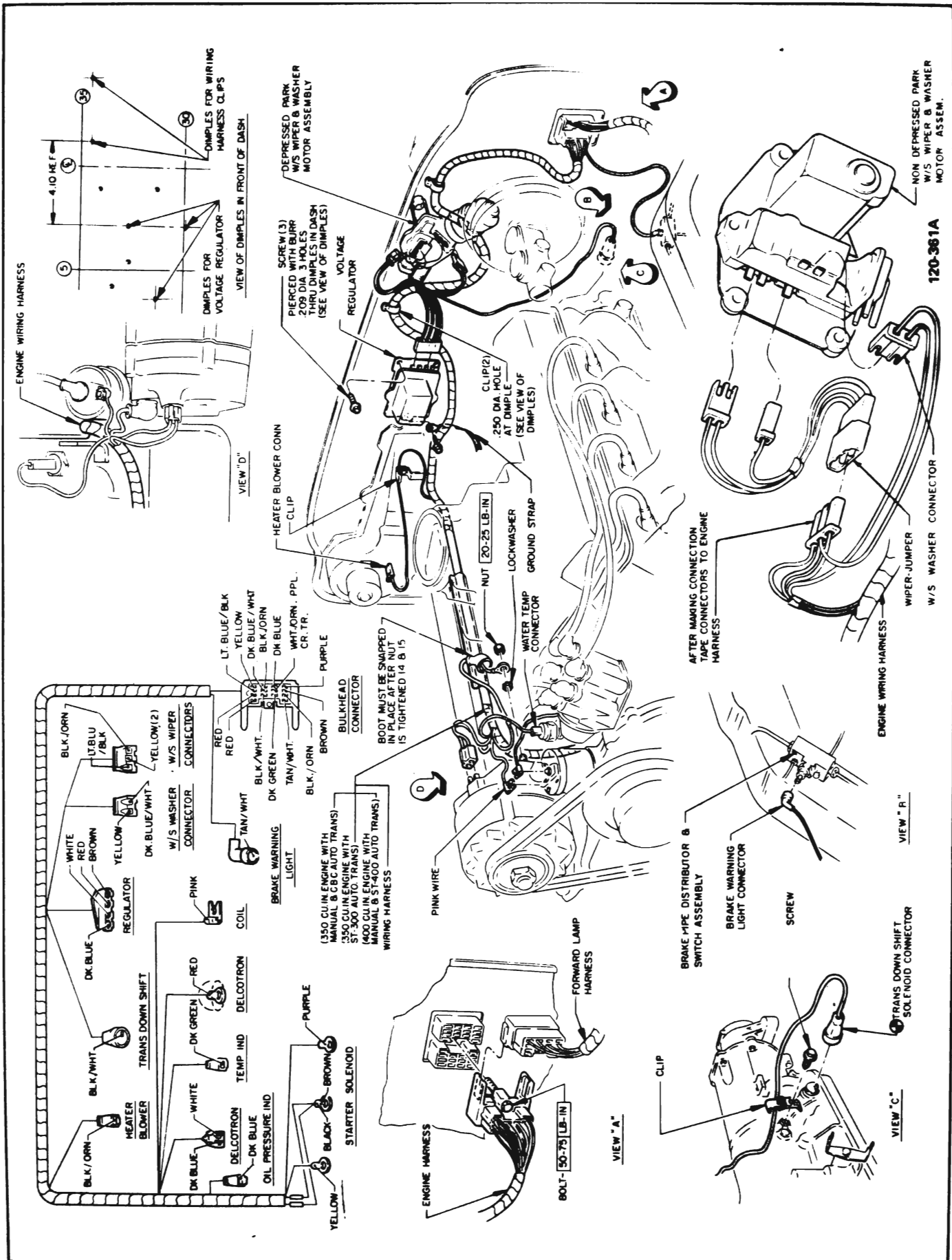
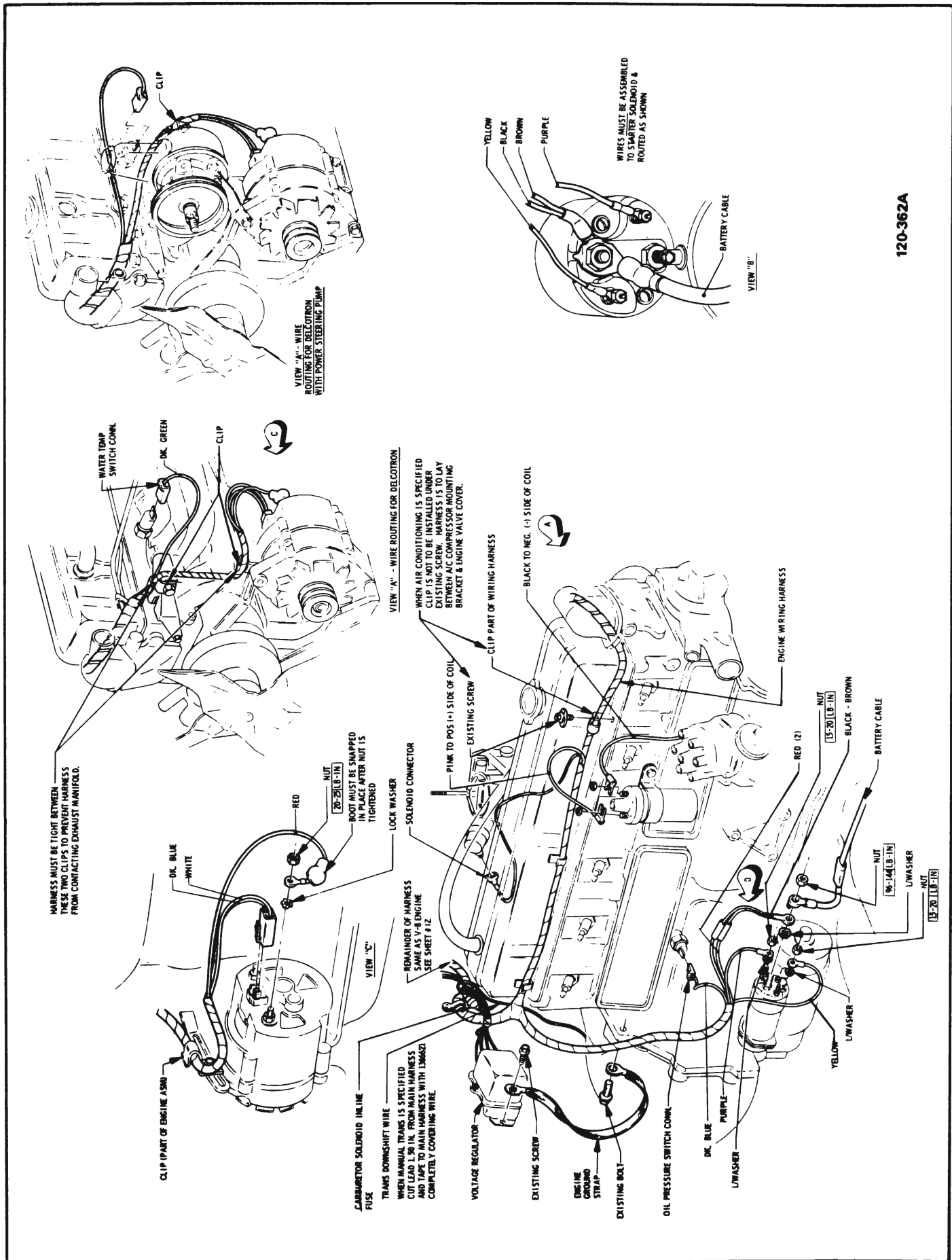

Figure 120-64 Engine Wiring Harness - 43-44000



120-362A

Figure 120-65 Engine Wiring Harness - L-6 Engine

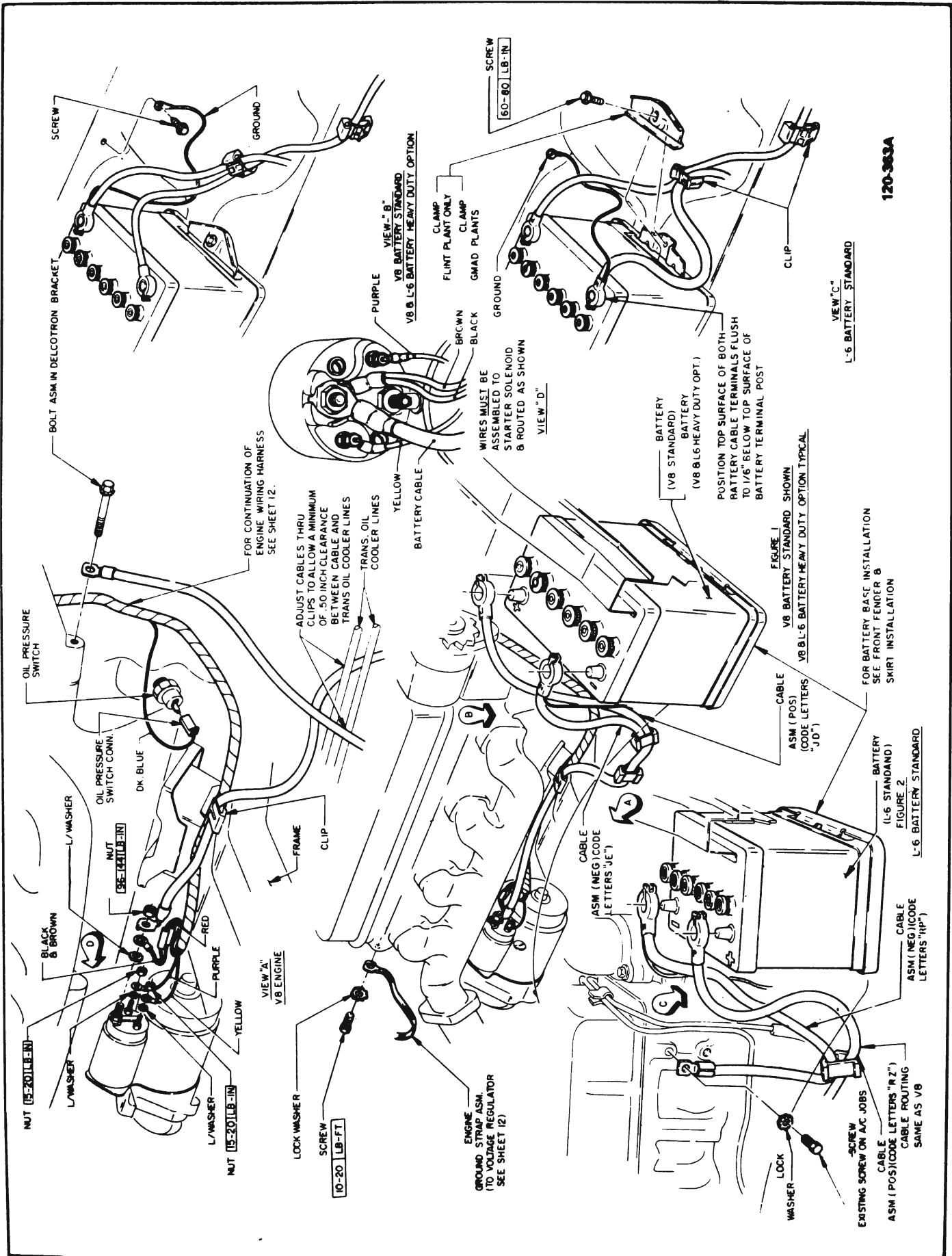

Figure 120-66 Starter and Battery Cable Installation - 43-44000

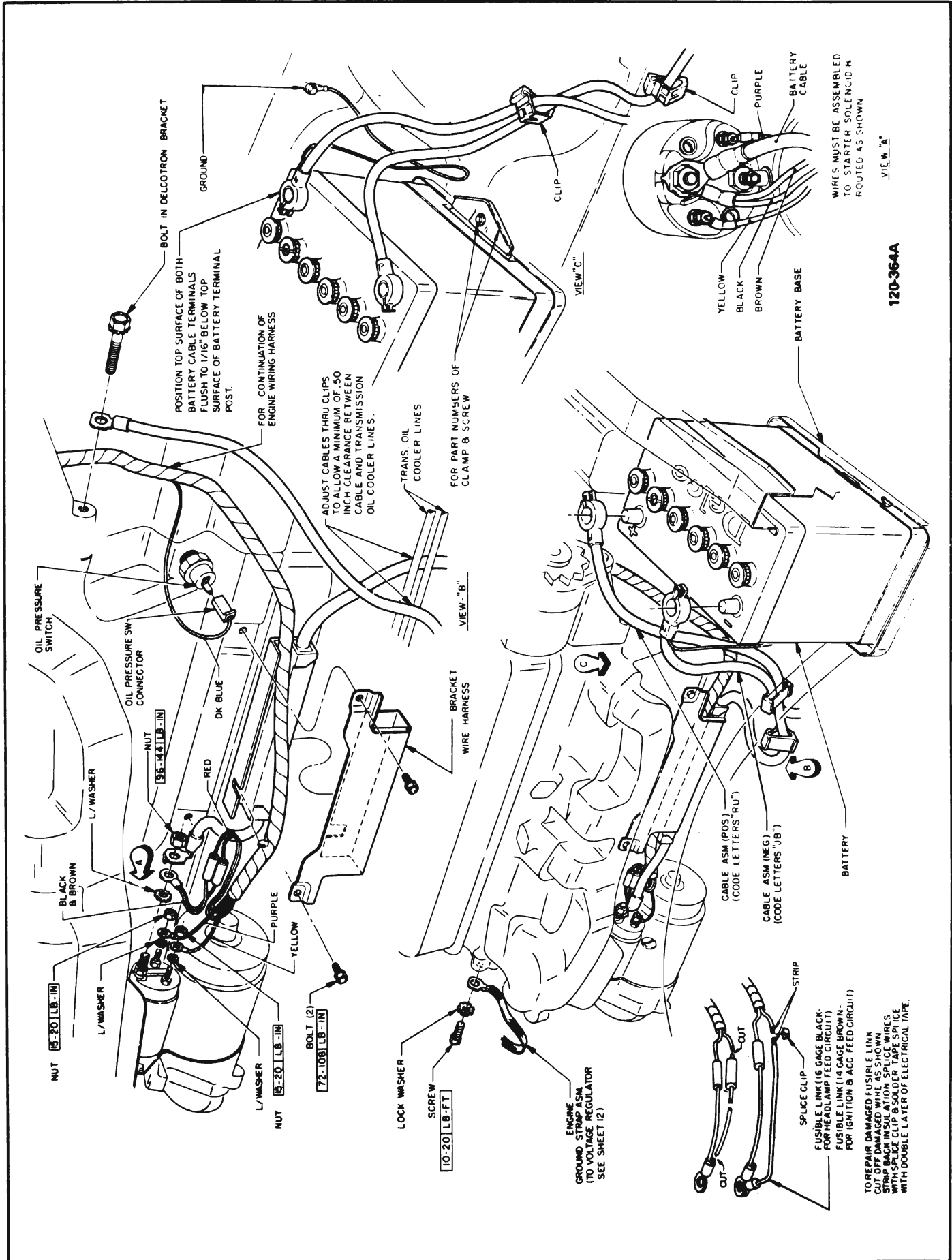

Figure 120-67 Starter and Battery Cable Installation - G.S. 400

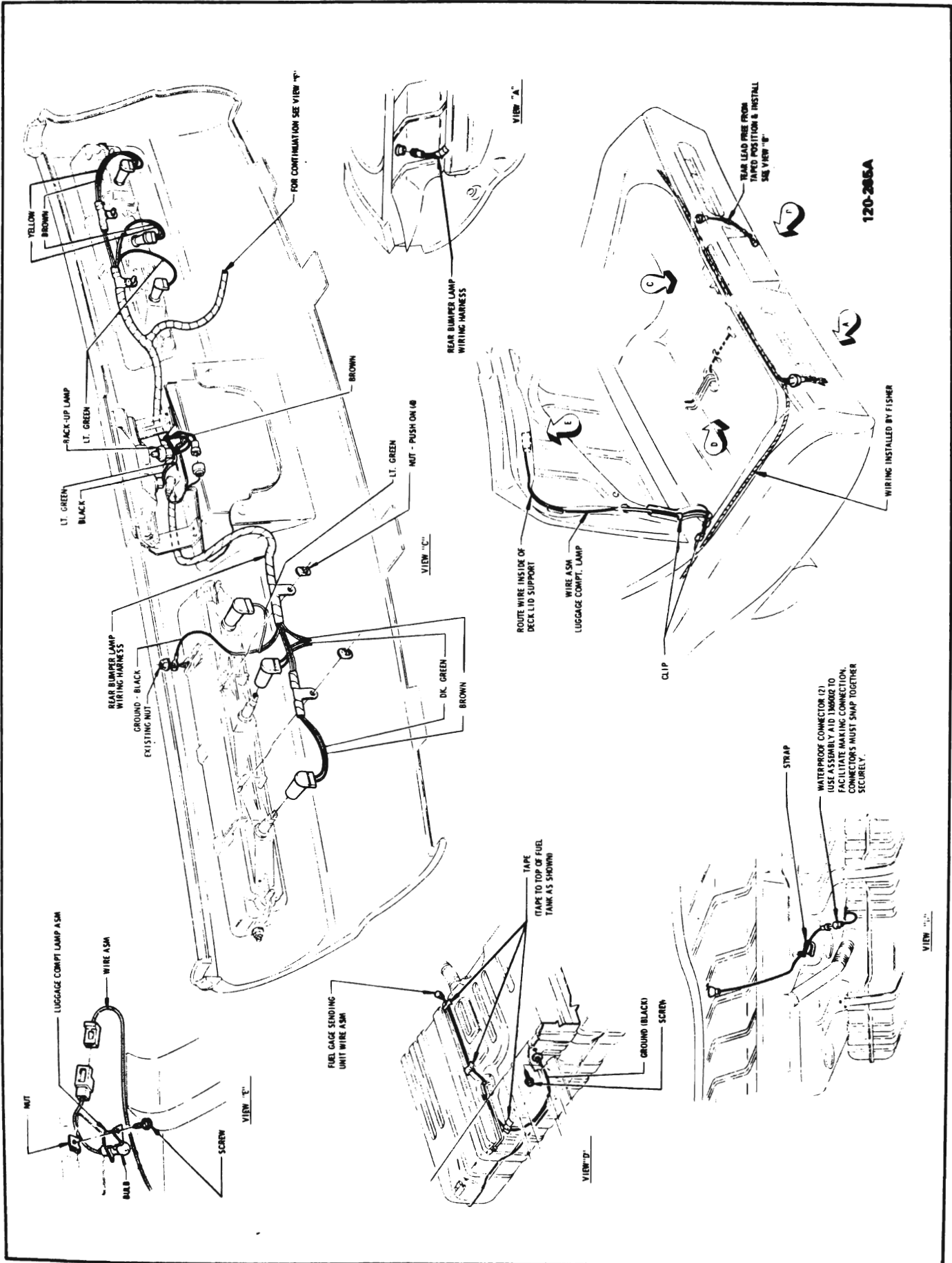

Figure 120-68 Rear Lamp and Fuel Gauge Wiring - 43-44000 Except Wagons

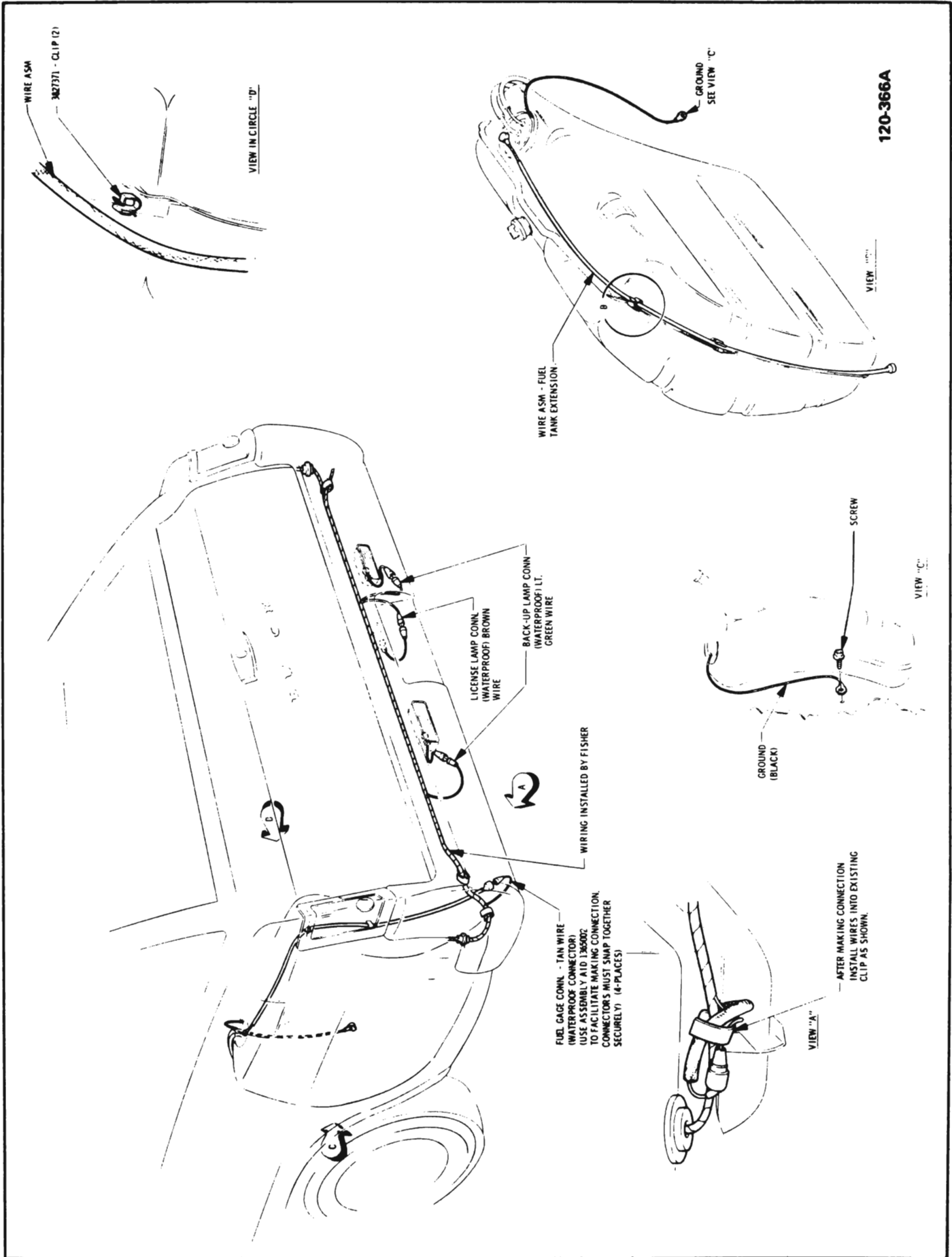

Figure 120-69 Rear Lamp and Fuel Gage Wiring - Wagons

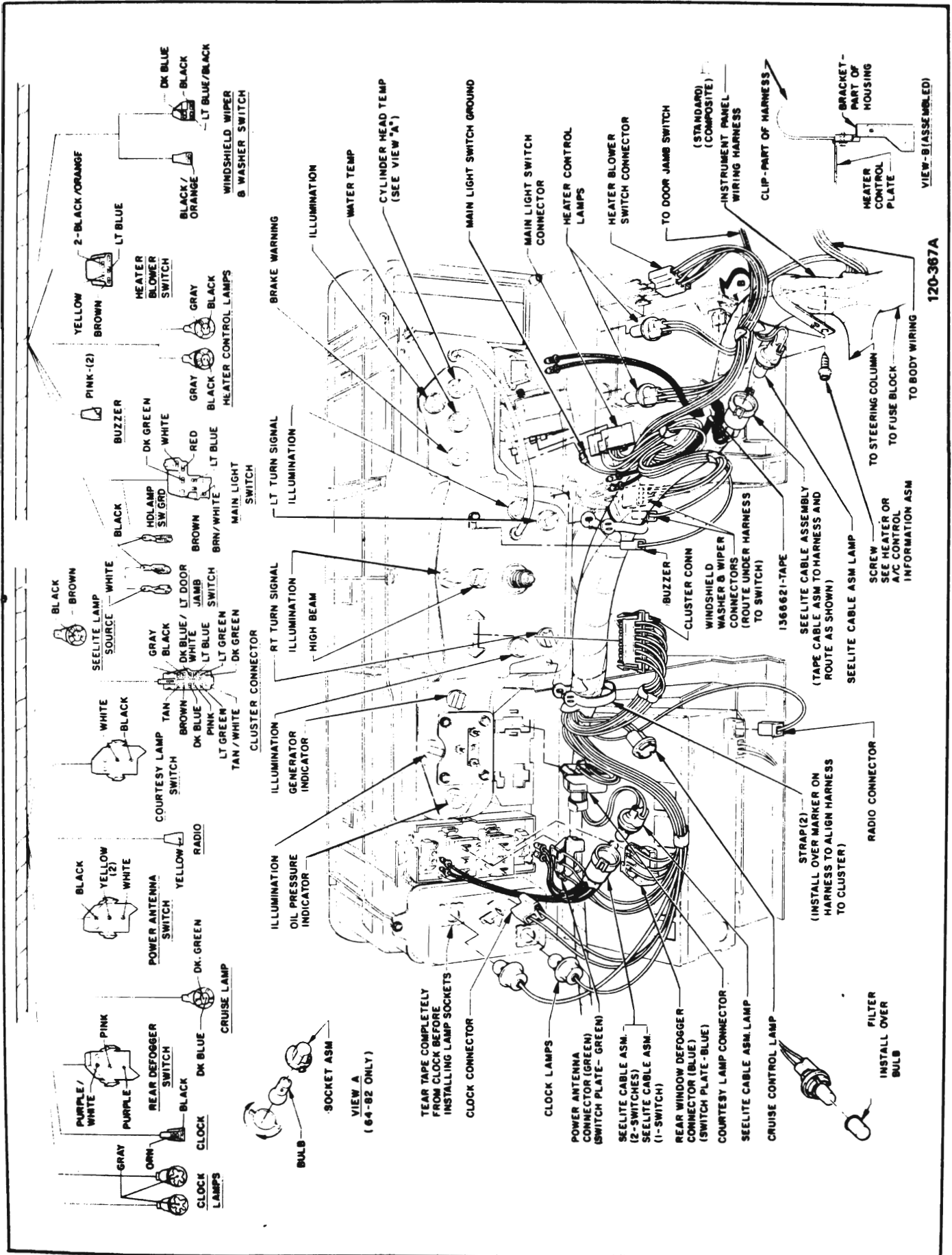

Figure 120-70 Instrument Cluster
Wiring - LeSabre, Wildcat and
Electra

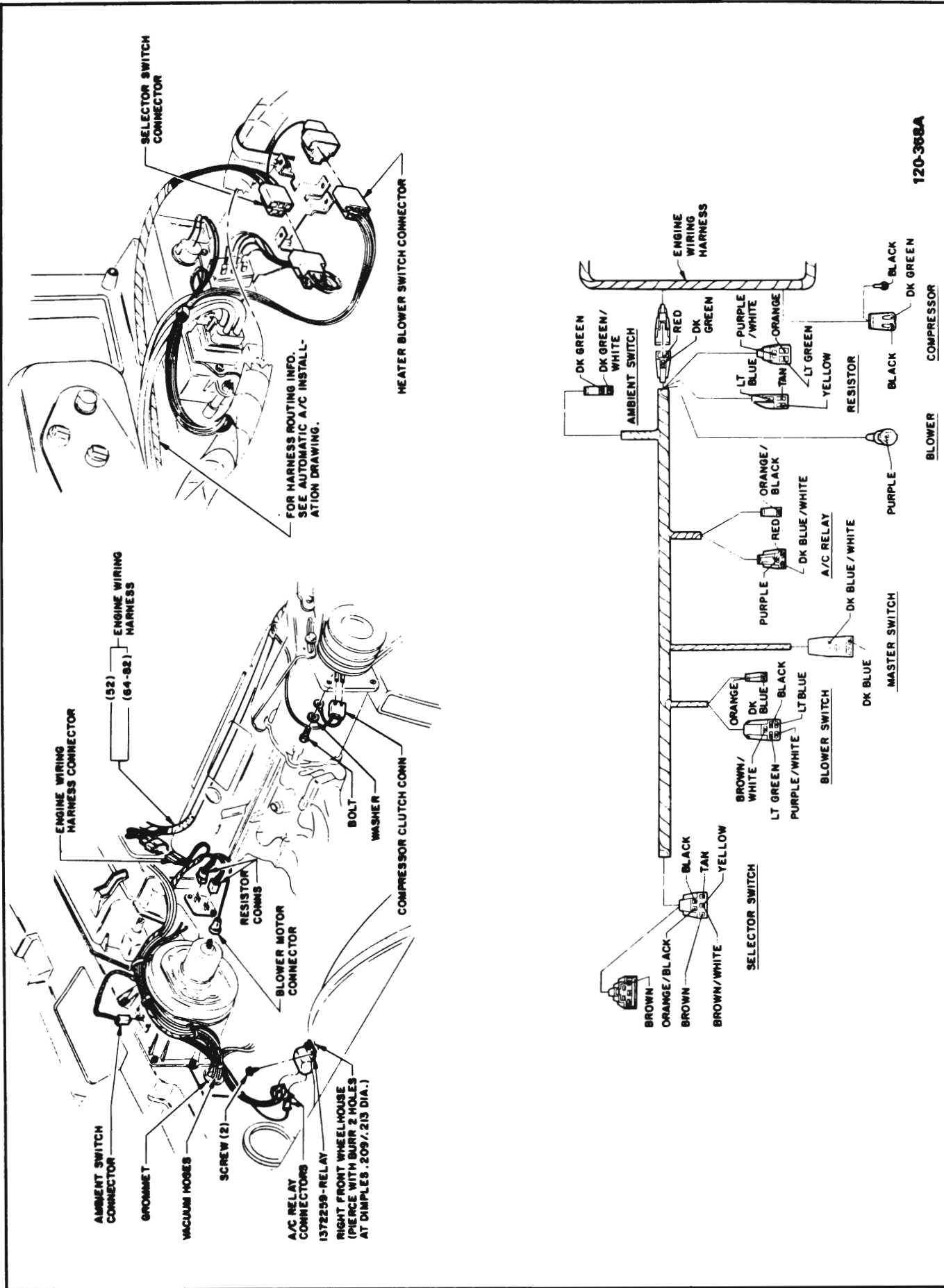

Figure 120-71 Instrument Panel Connections - LeSabre, Wildcat and Electra

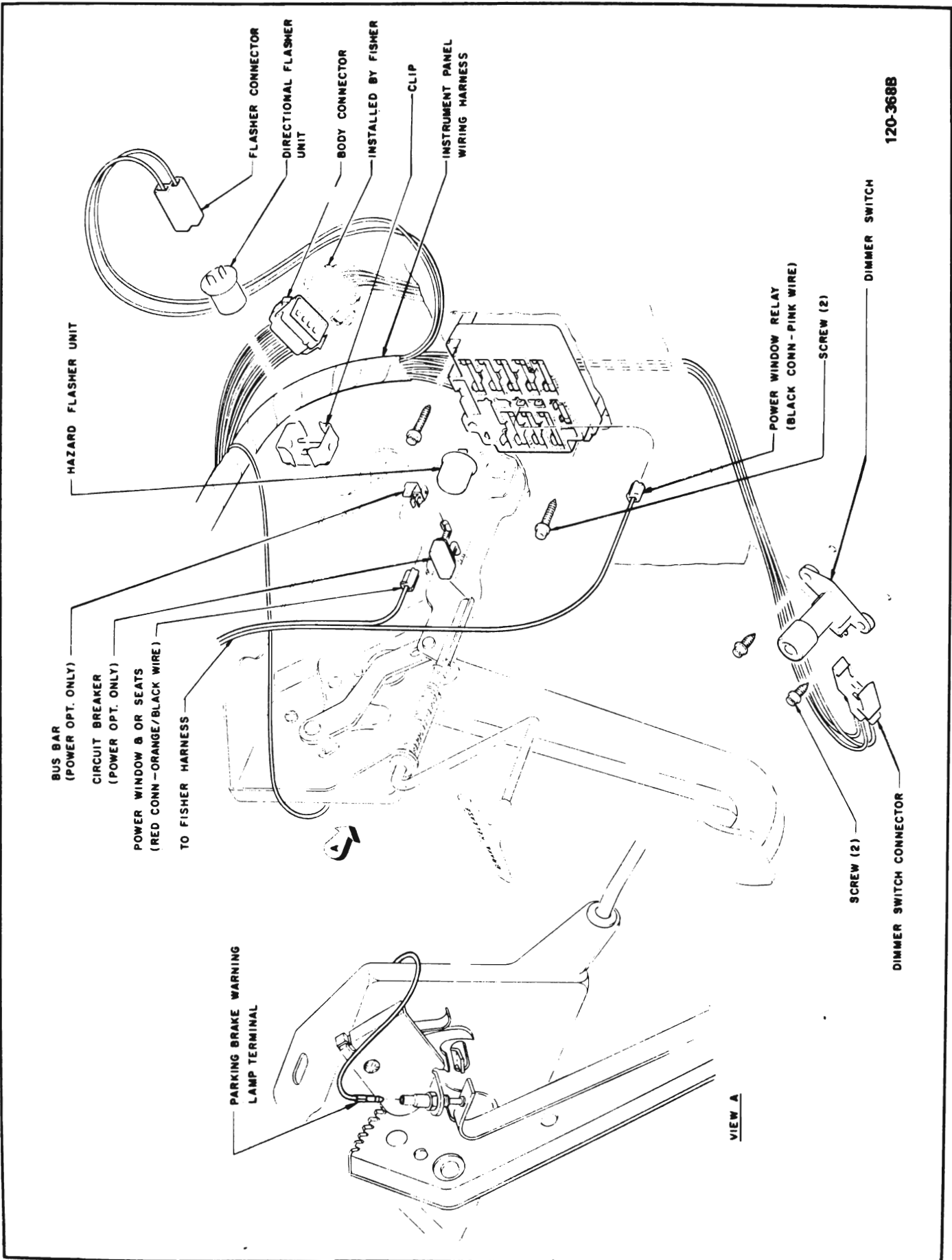

Figure 120-72 Fuse Block Wiring - LeSabre, Wildcat and Electra

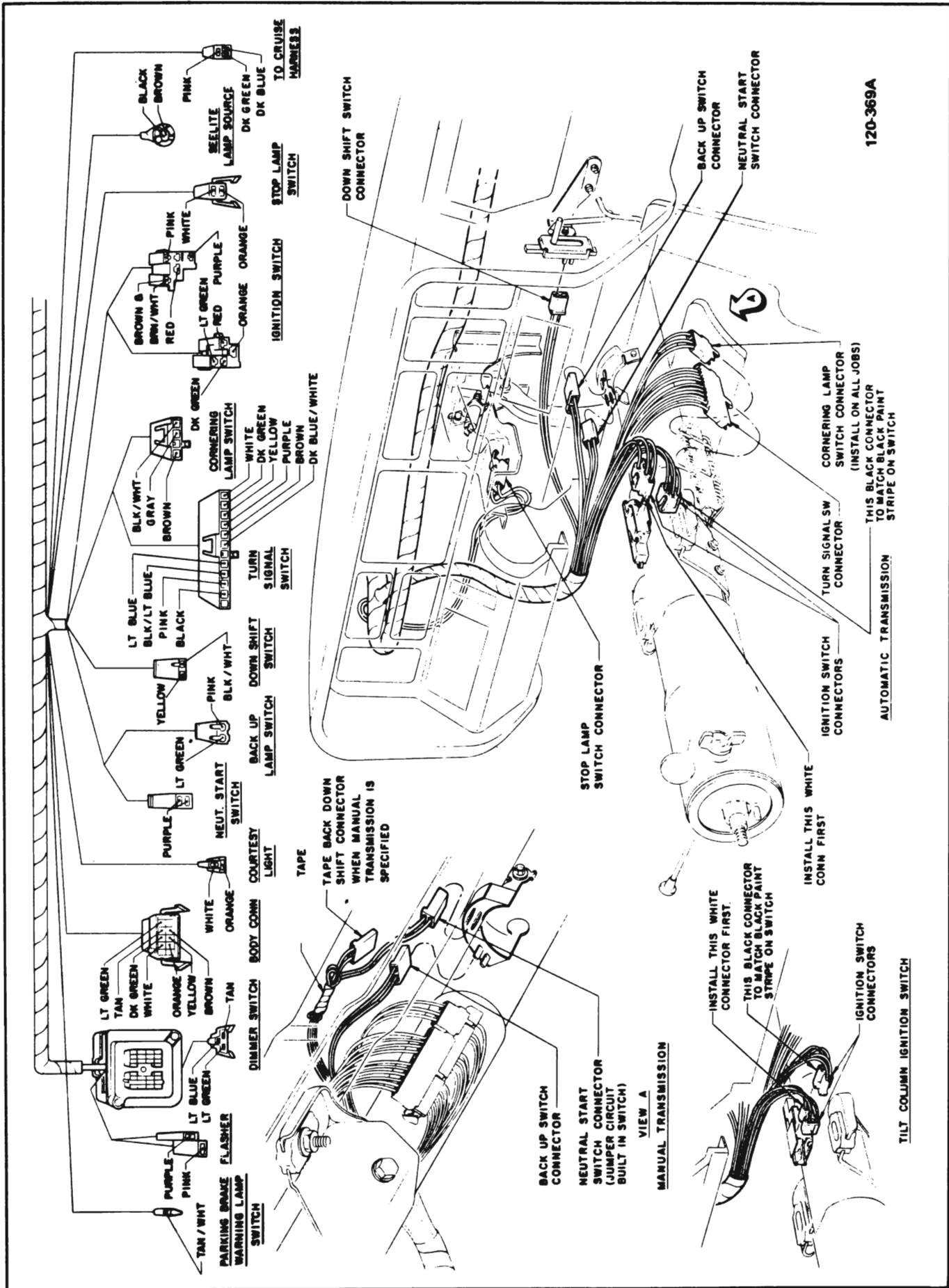

Figure 120-73 Steering Column Wiring - LeSabre, Wildcat and Electra

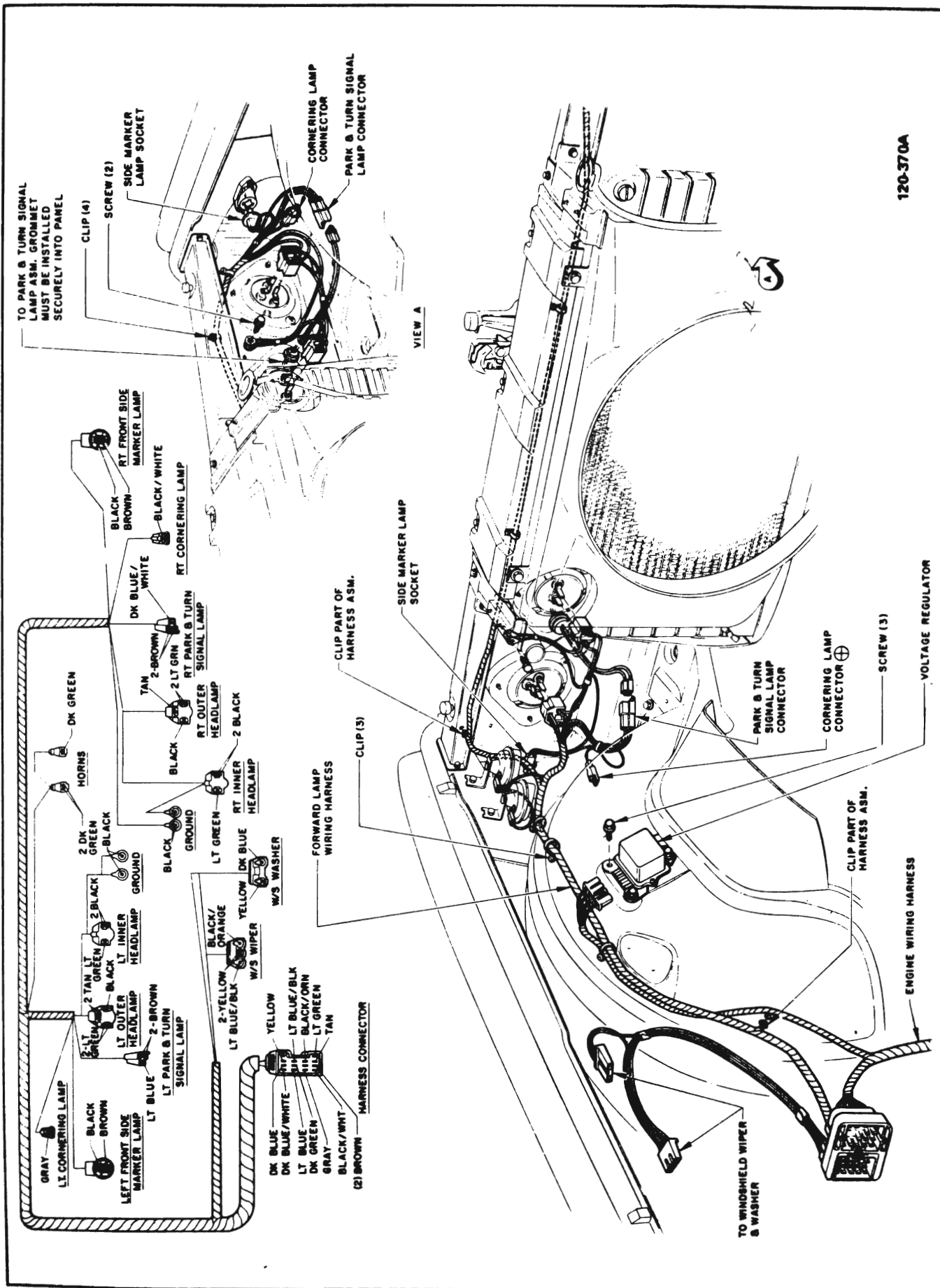

Figure 120-74 Forward Lamp Wiring Harness - LeSabre, Wildcat and Electra

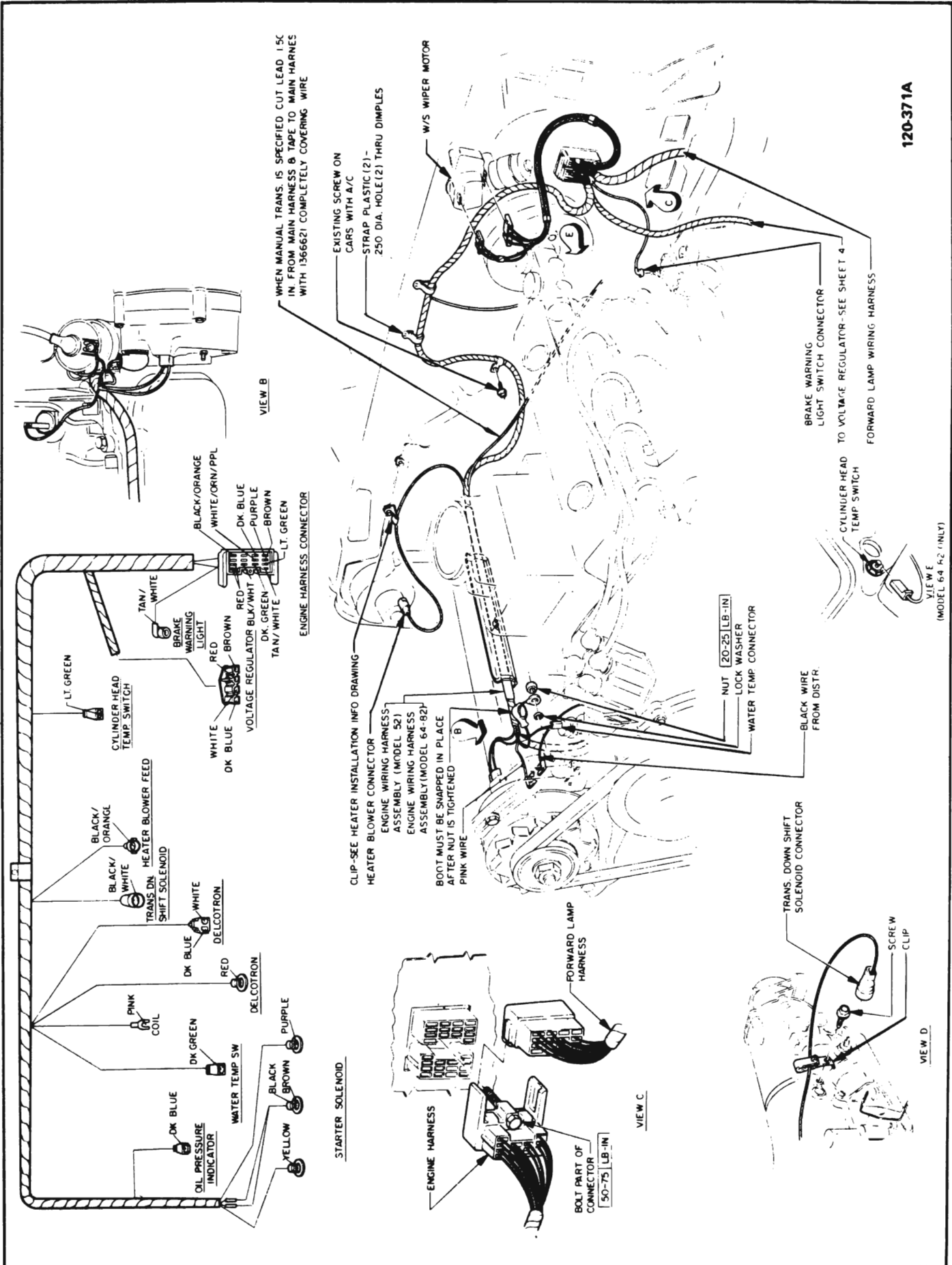

Figure 120-75 Engine Wiring Harness - LeSabre, Wildcat and Electra

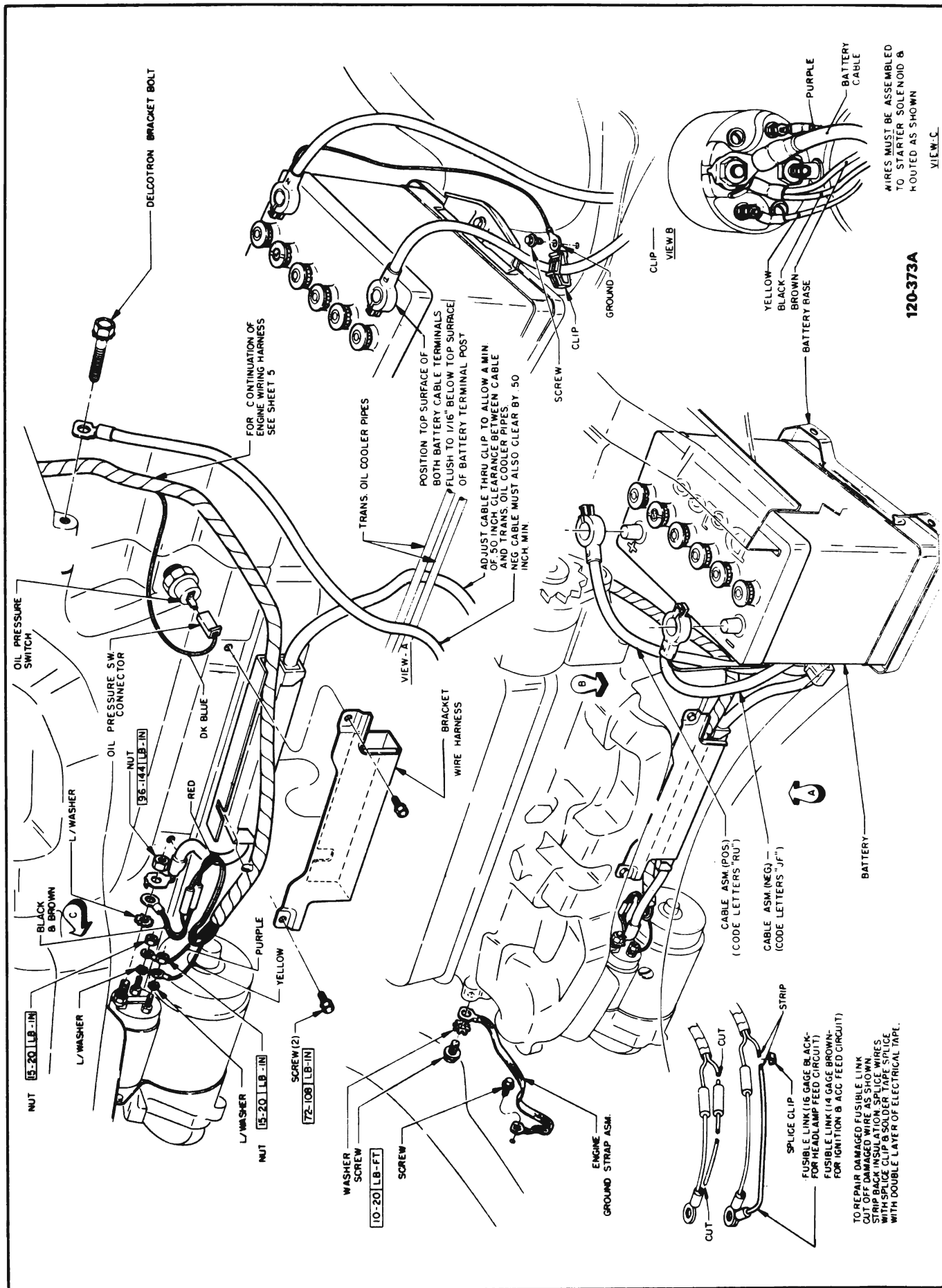

Figure 120-77 Starter and Battery Cable Installation - Wildcat and Electra

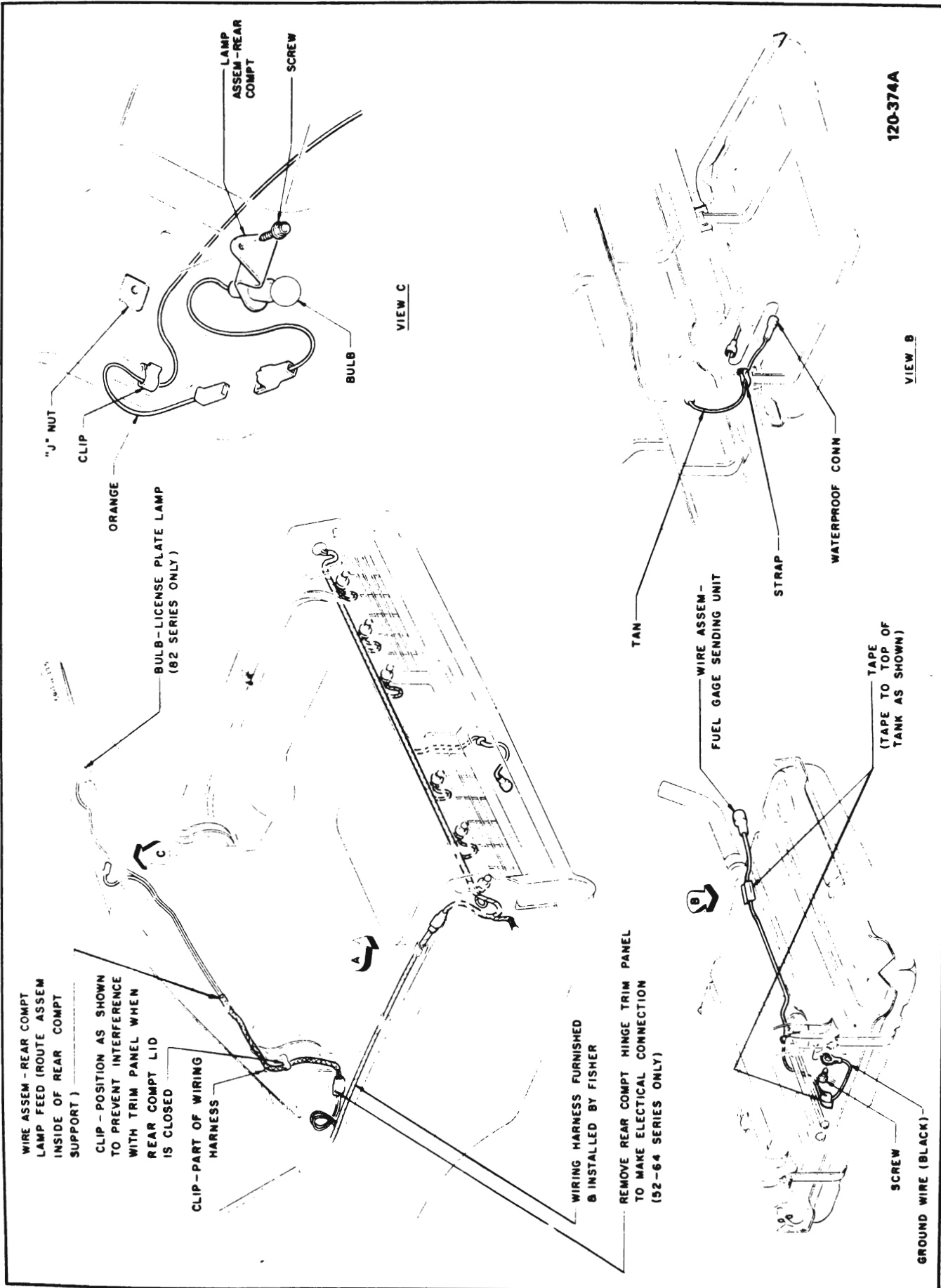

Figure 120-78 Rear Lamp and Fuel Gauge Wiring - LeSabre, Wildcat and Electra

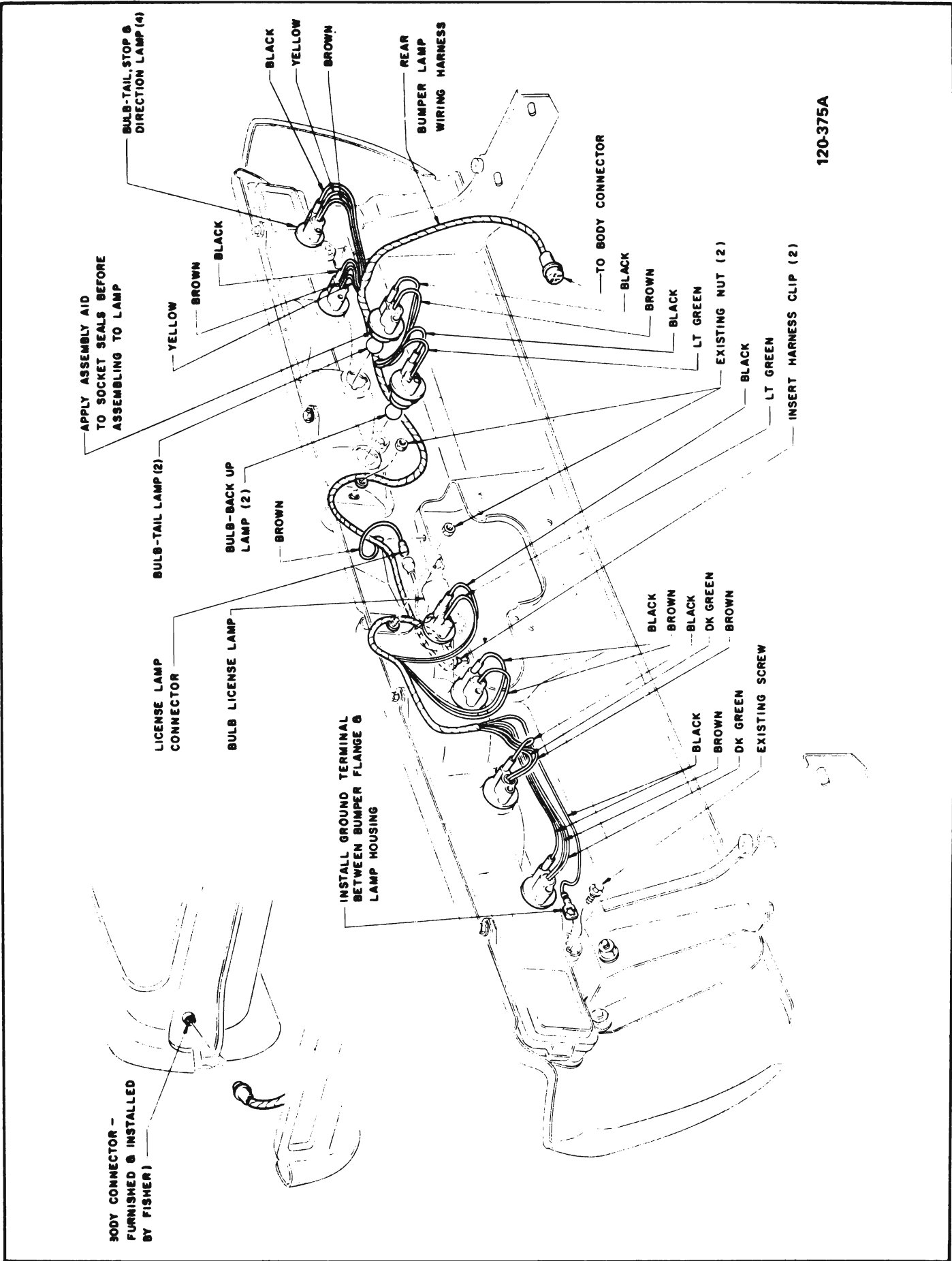

Figure 120-79 Rear Bumper Wiring - LeSabre, Wildcat and Electra

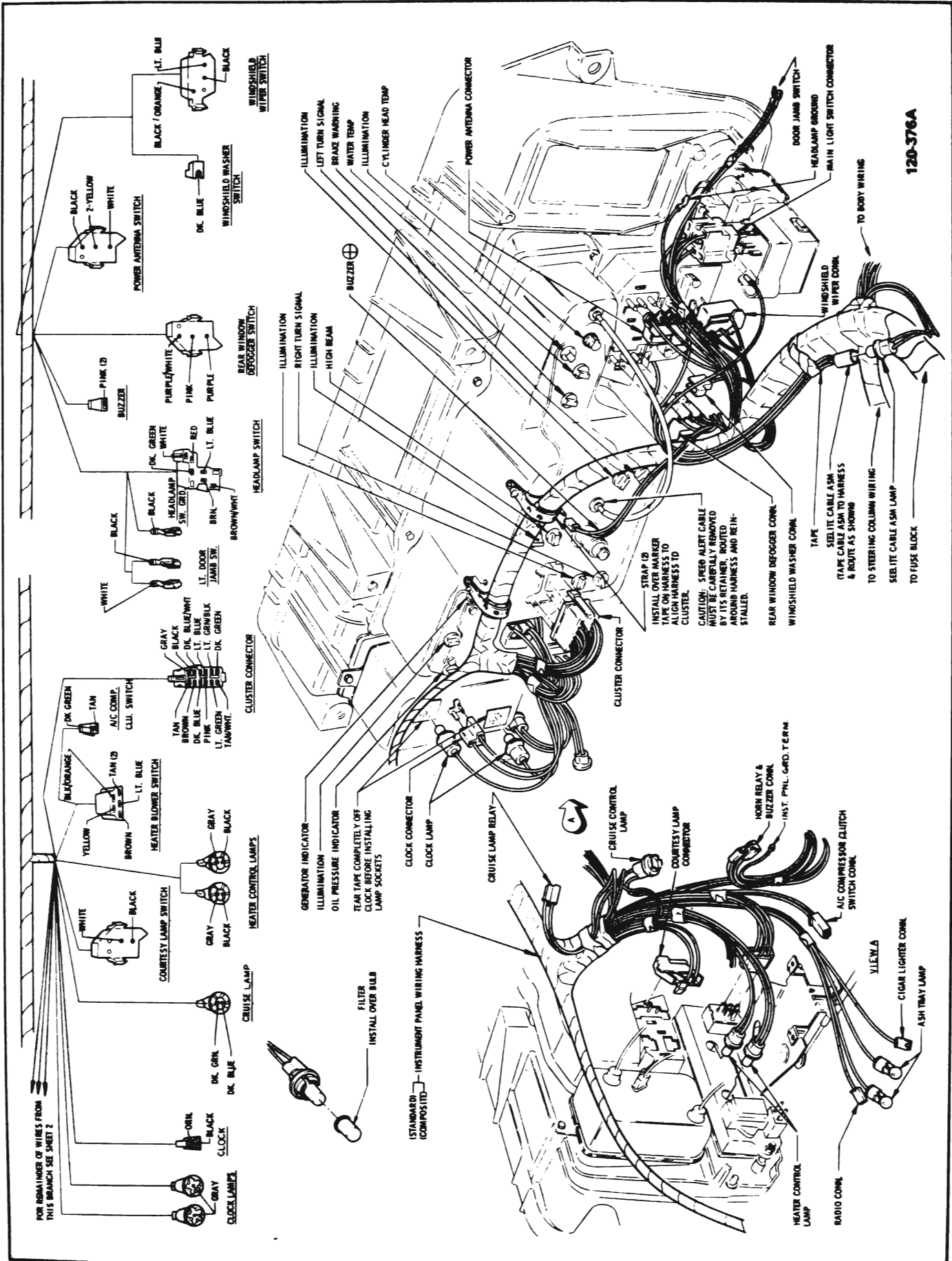

Figure 120-80 Instrument Cluster Wiring - Riviera

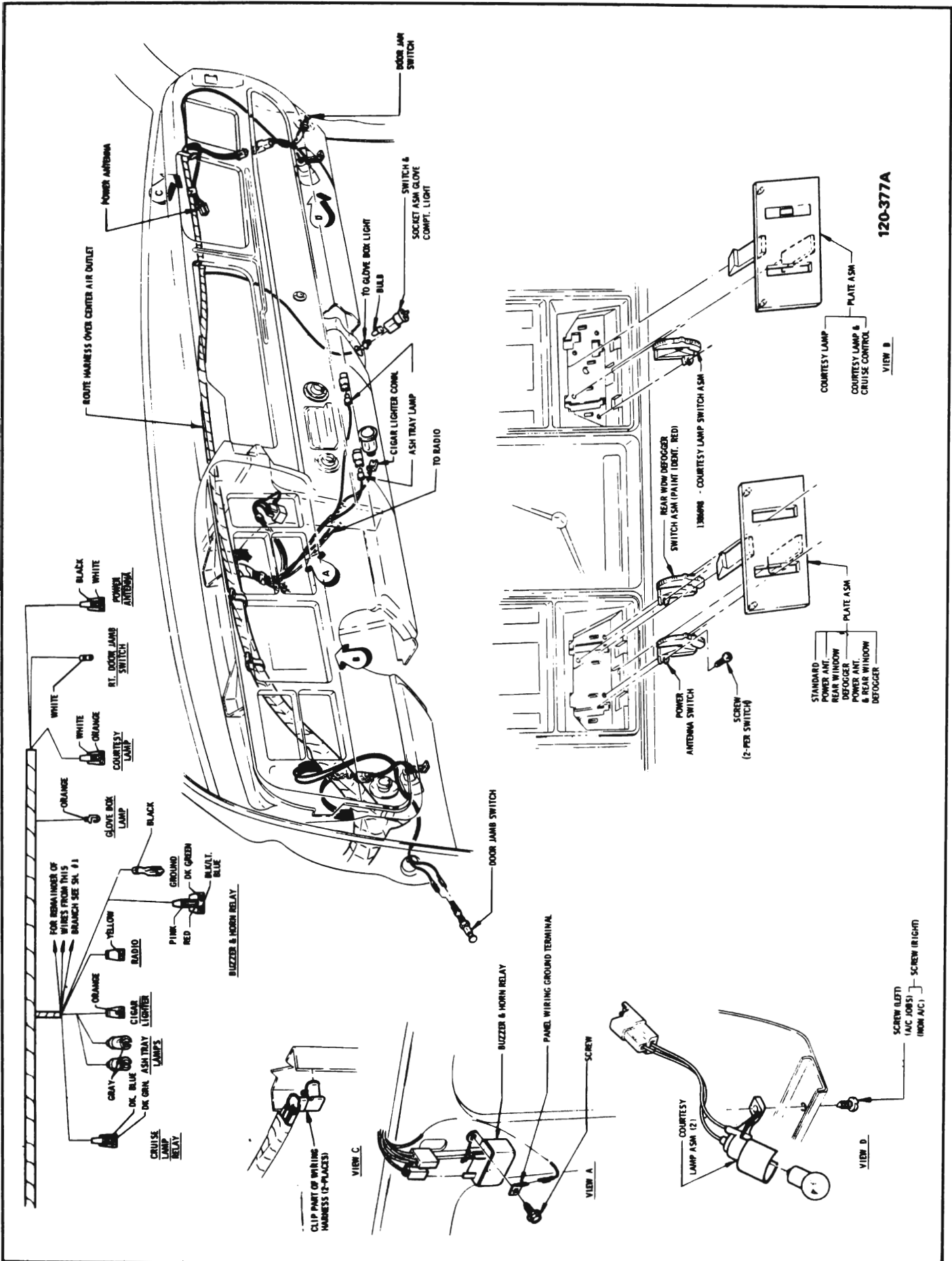

Figure 120-81 Instrument Panel Wiring - Riviera

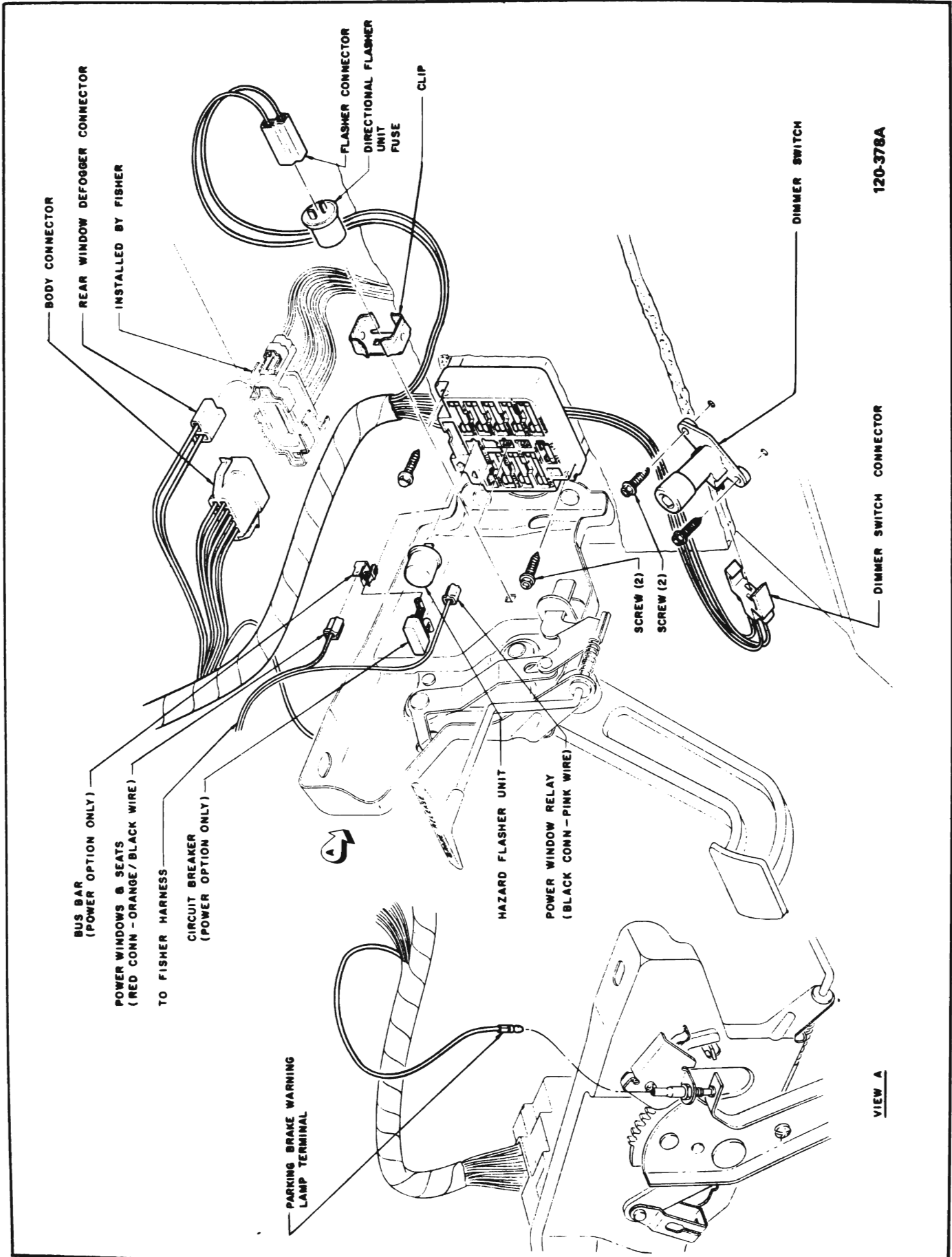

Figure 120-82 Fuse Block Wiring - Riviera

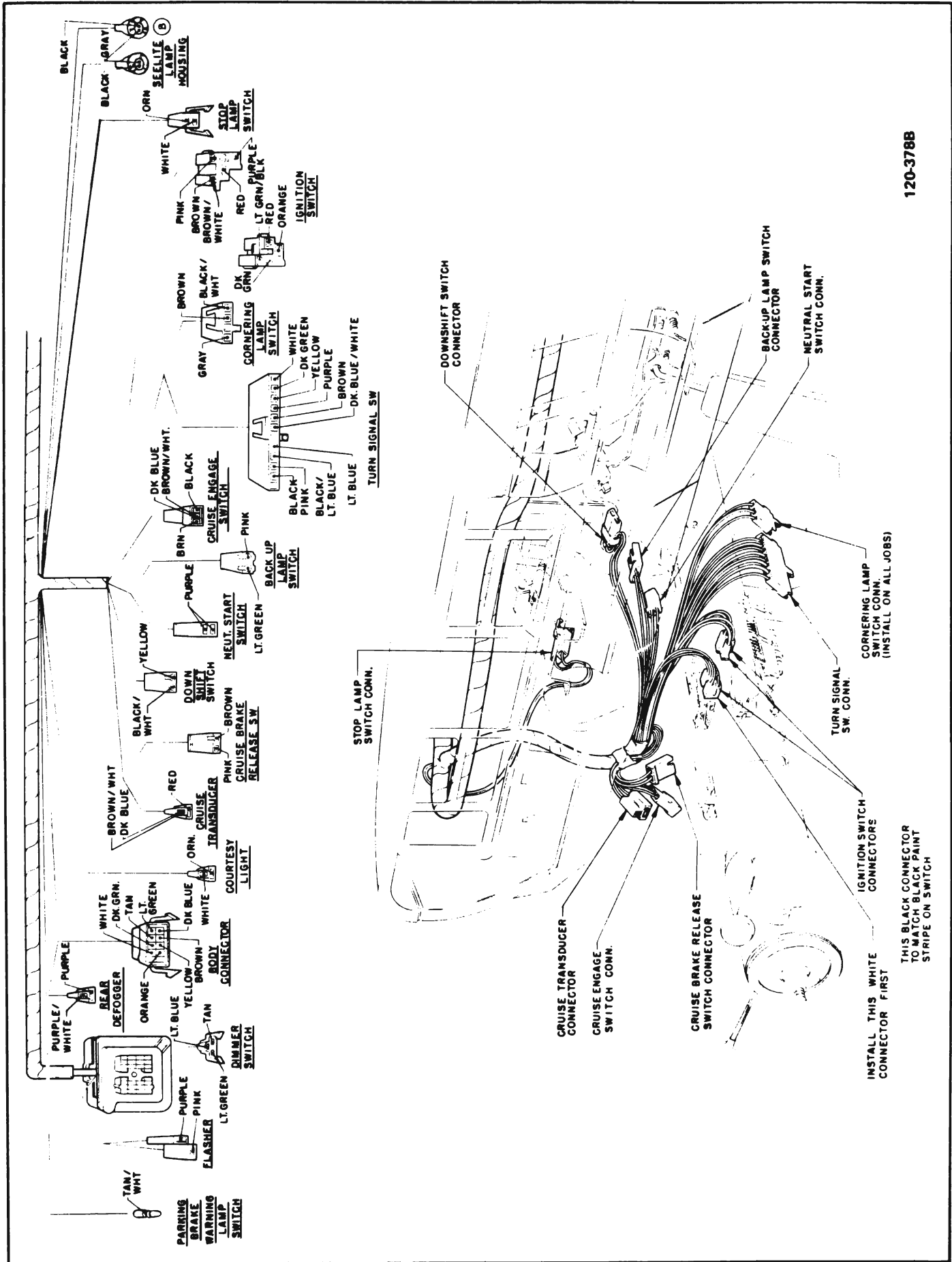

Figure 120-83 Steering Column Wiring - Riviera

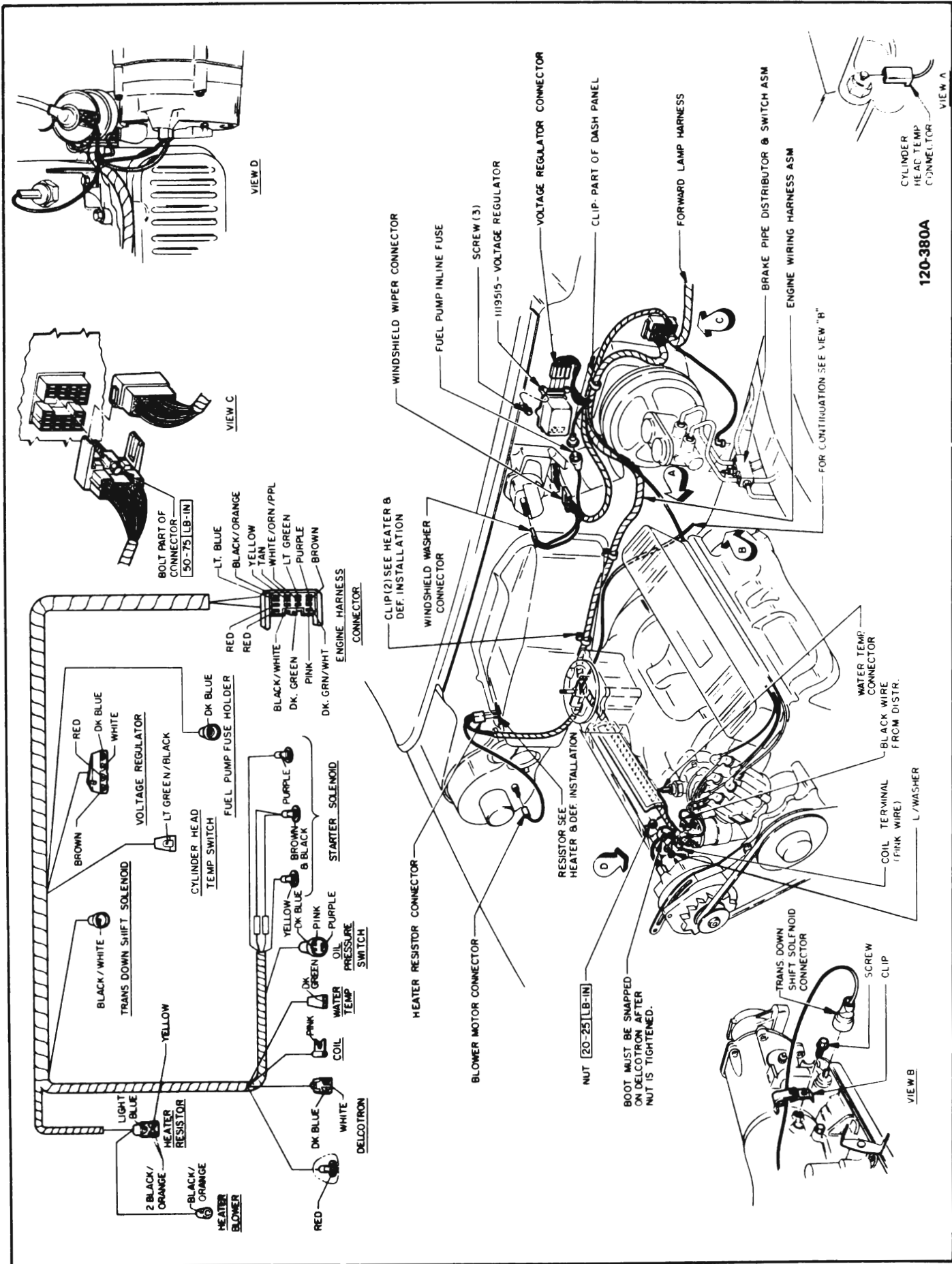

Figure 120-85 Engine Wiring Harness - Riviera

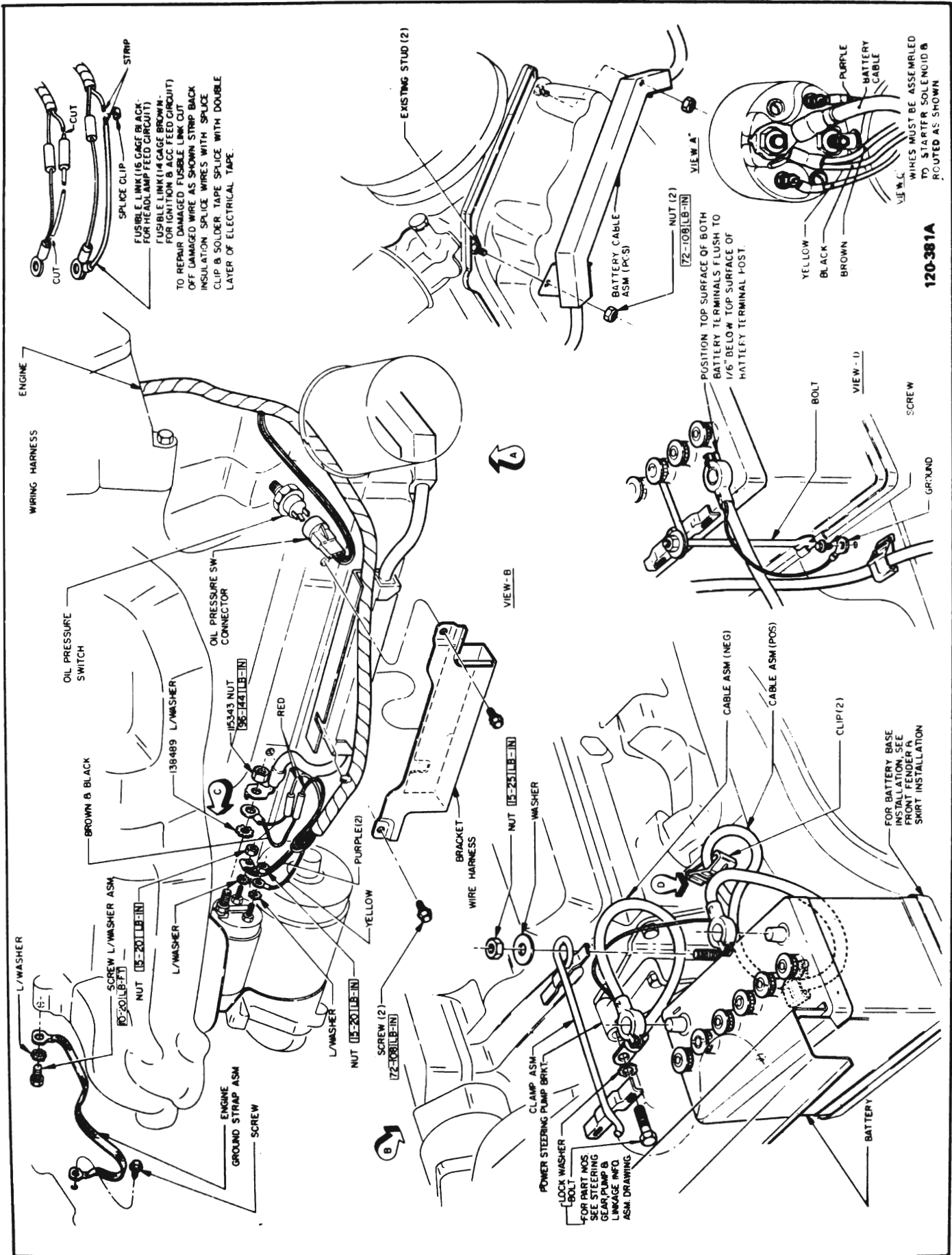

Figure 120-86 Starter and Battery Cable Installation - Riviera

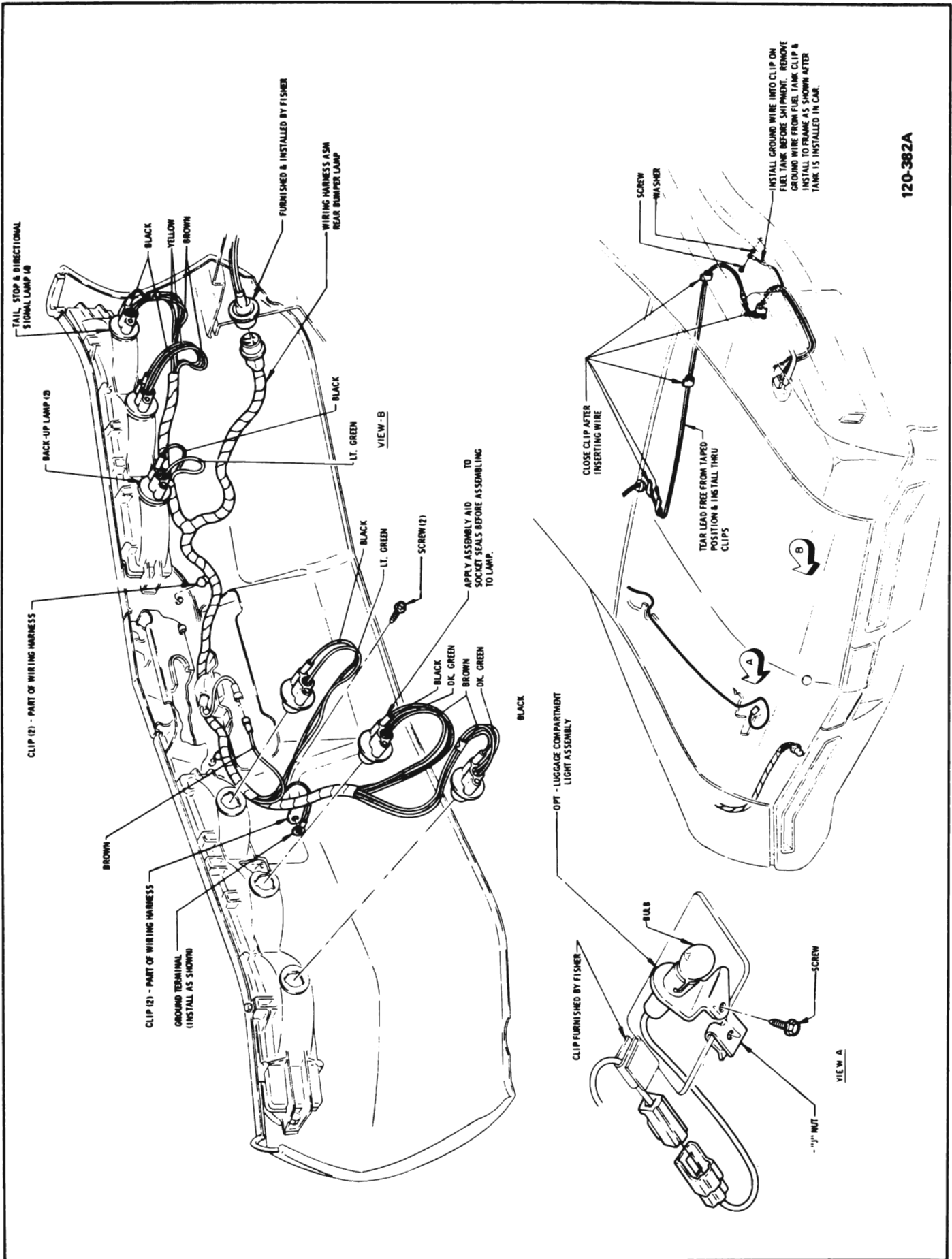

Figure 120-87 Rear Lamp, Fuel Pump and Gauge Wiring - Riviera

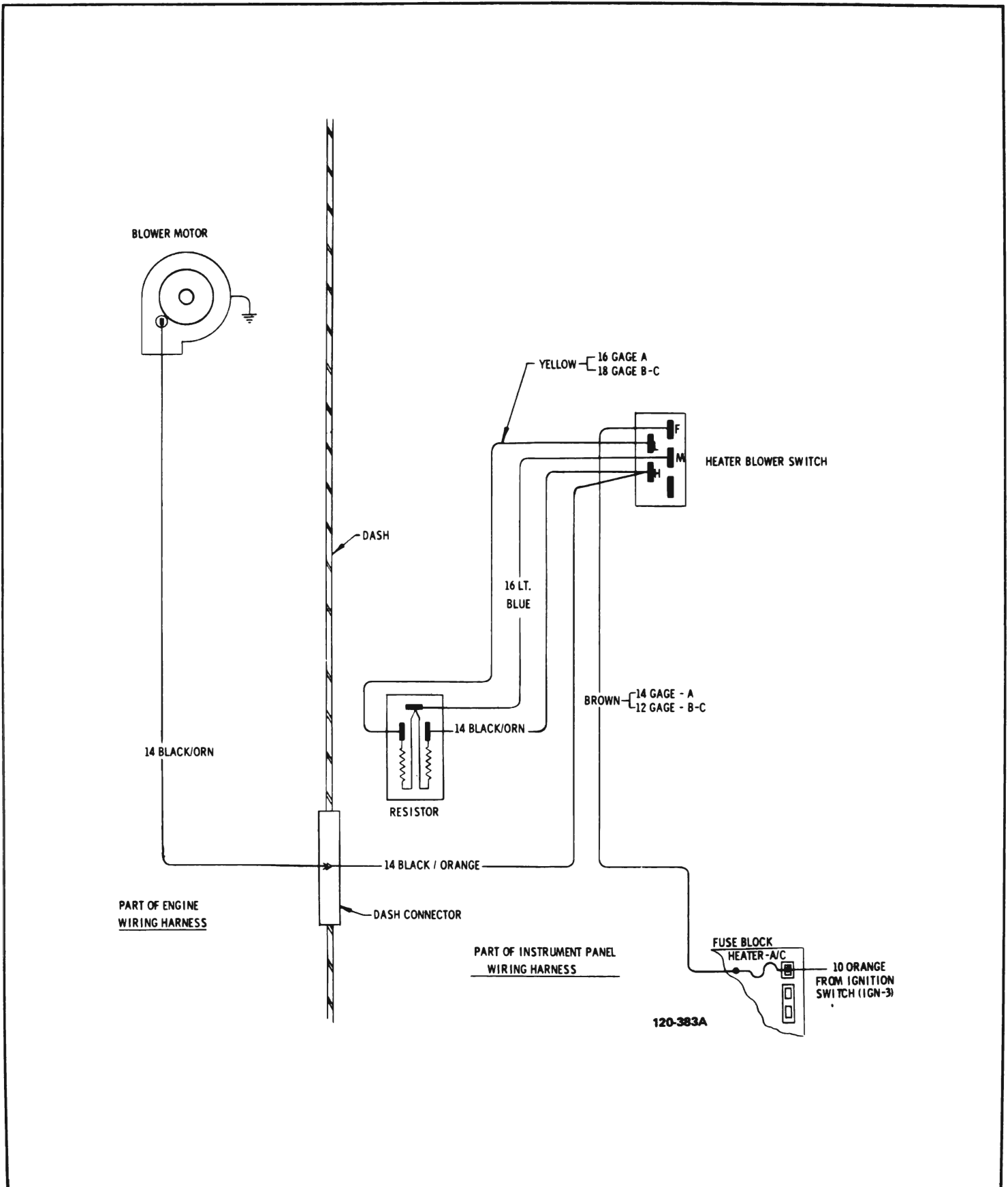

Figure I20-88 Heater Wiring Diagram - Except Riviera

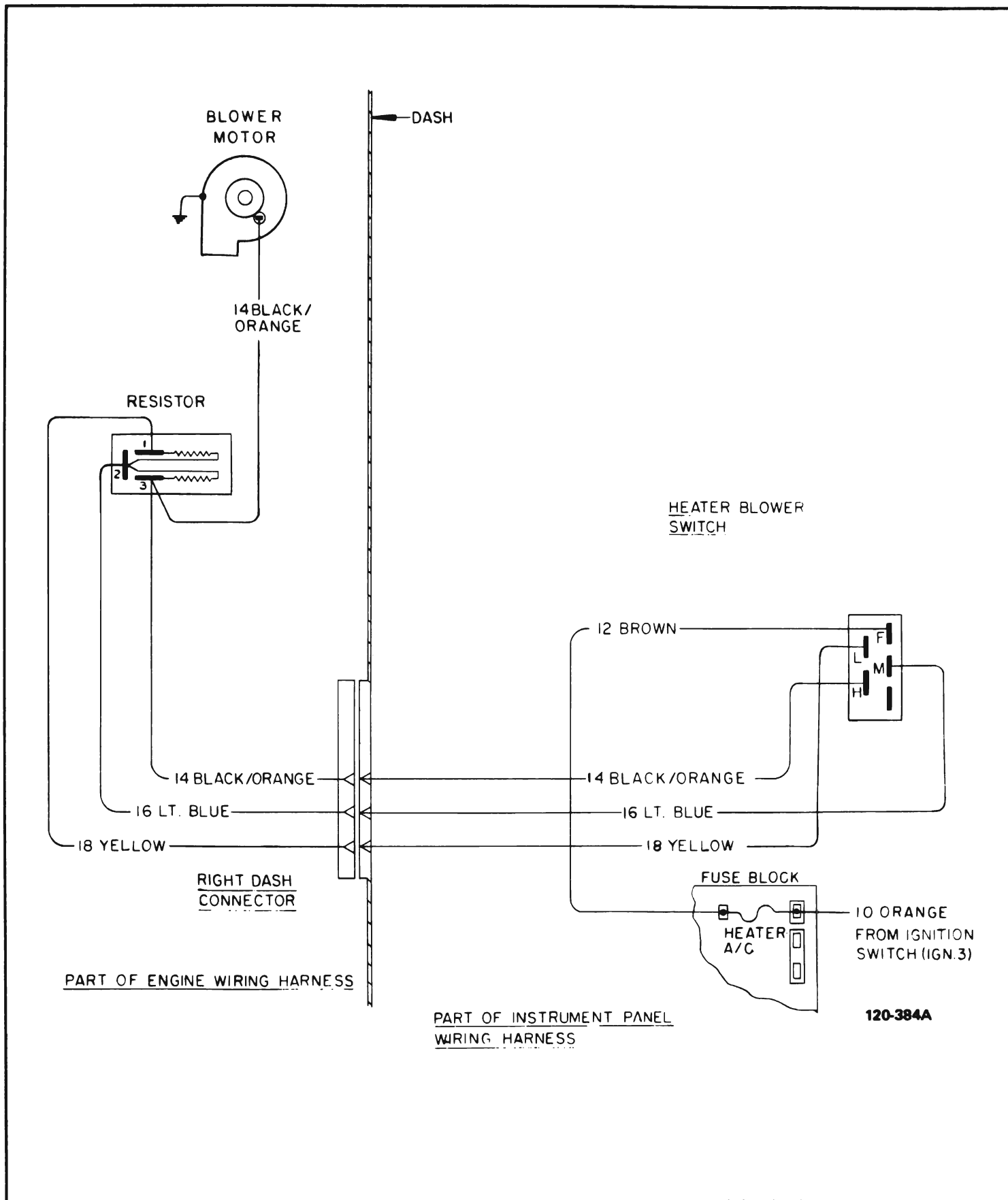

Figure I20-89 Heater Wiring Diagram - Riviera

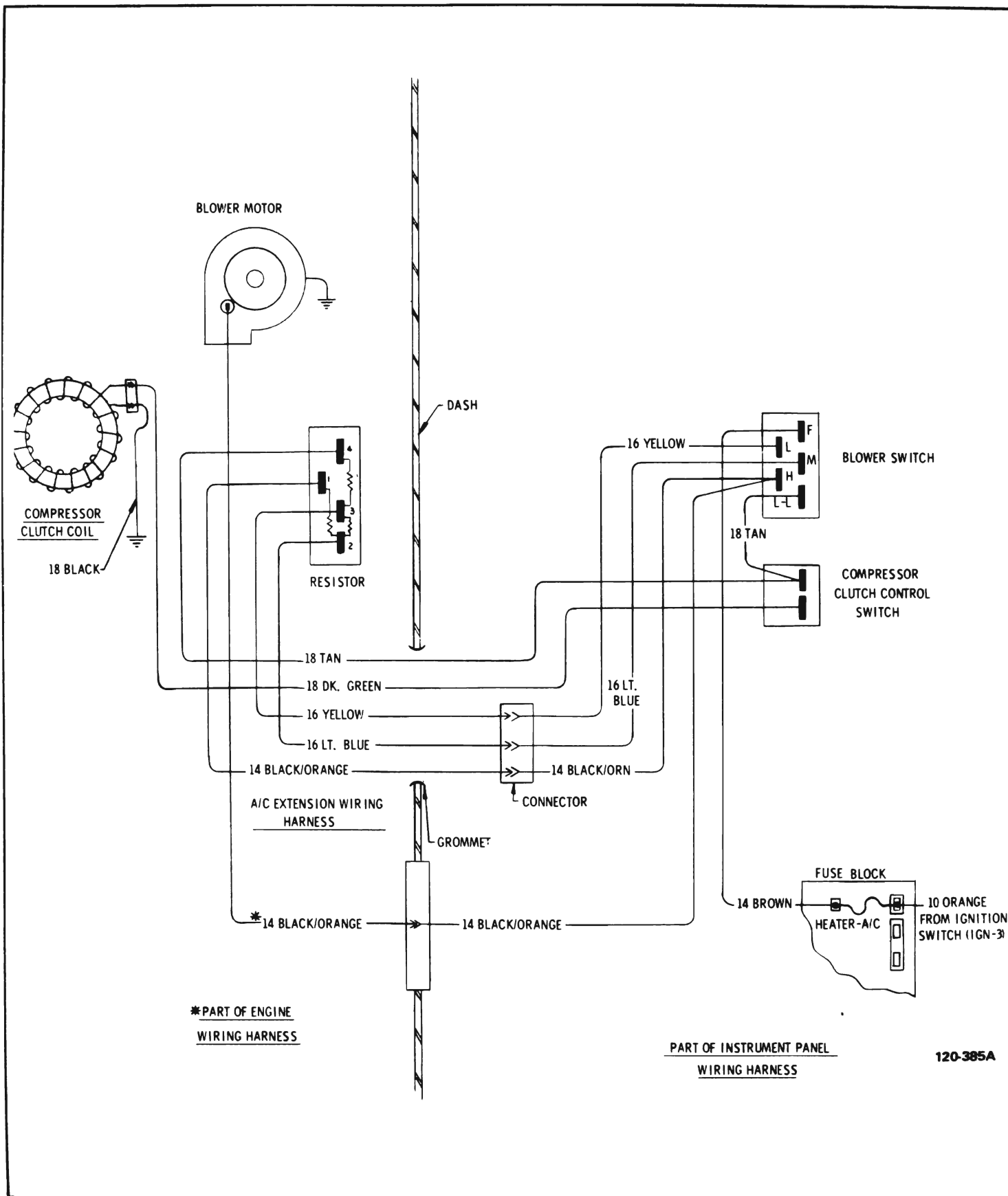

Figure I20-90 Air Conditioner
Wiring Diagram - 43-44000

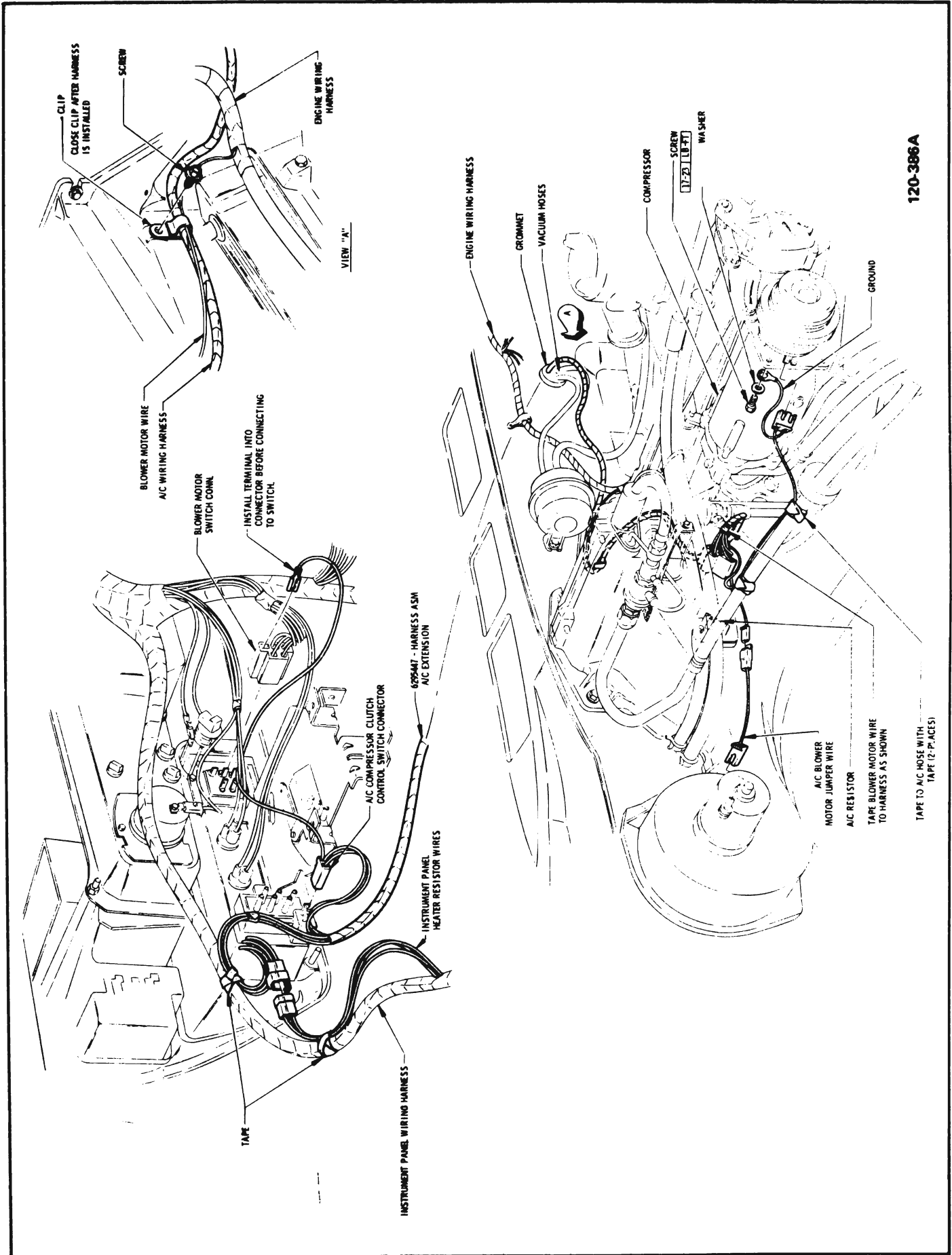

Figure 120-91 Air Conditioner Wiring - 43-44000

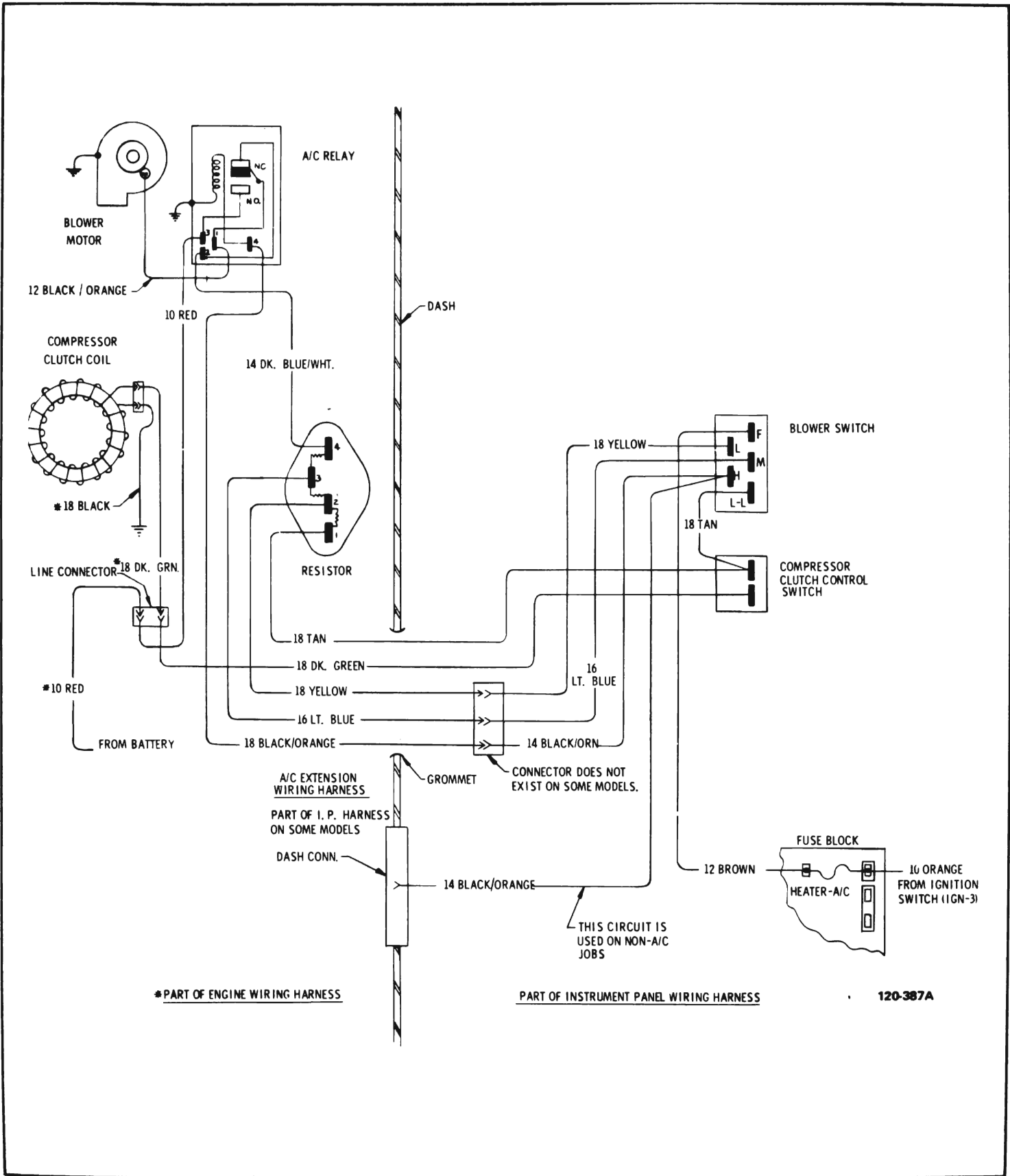
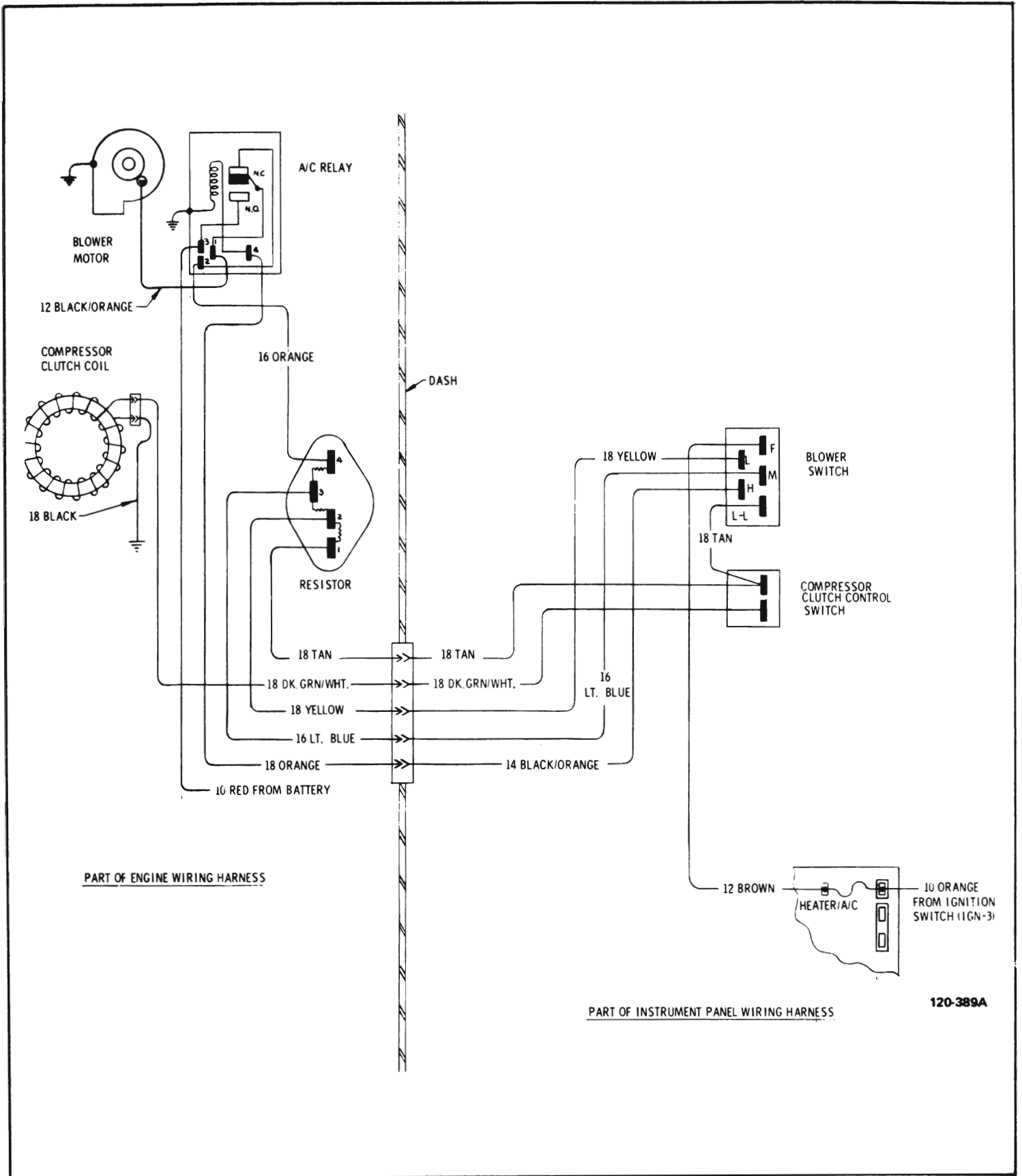

Figure 120-92 Manual Air Conditioner Wiring Diagram - LeSabre, Wildcat and Electra



120-389A

Figure I20-93 Manual Air Conditioner Wiring Diagram - Riviera

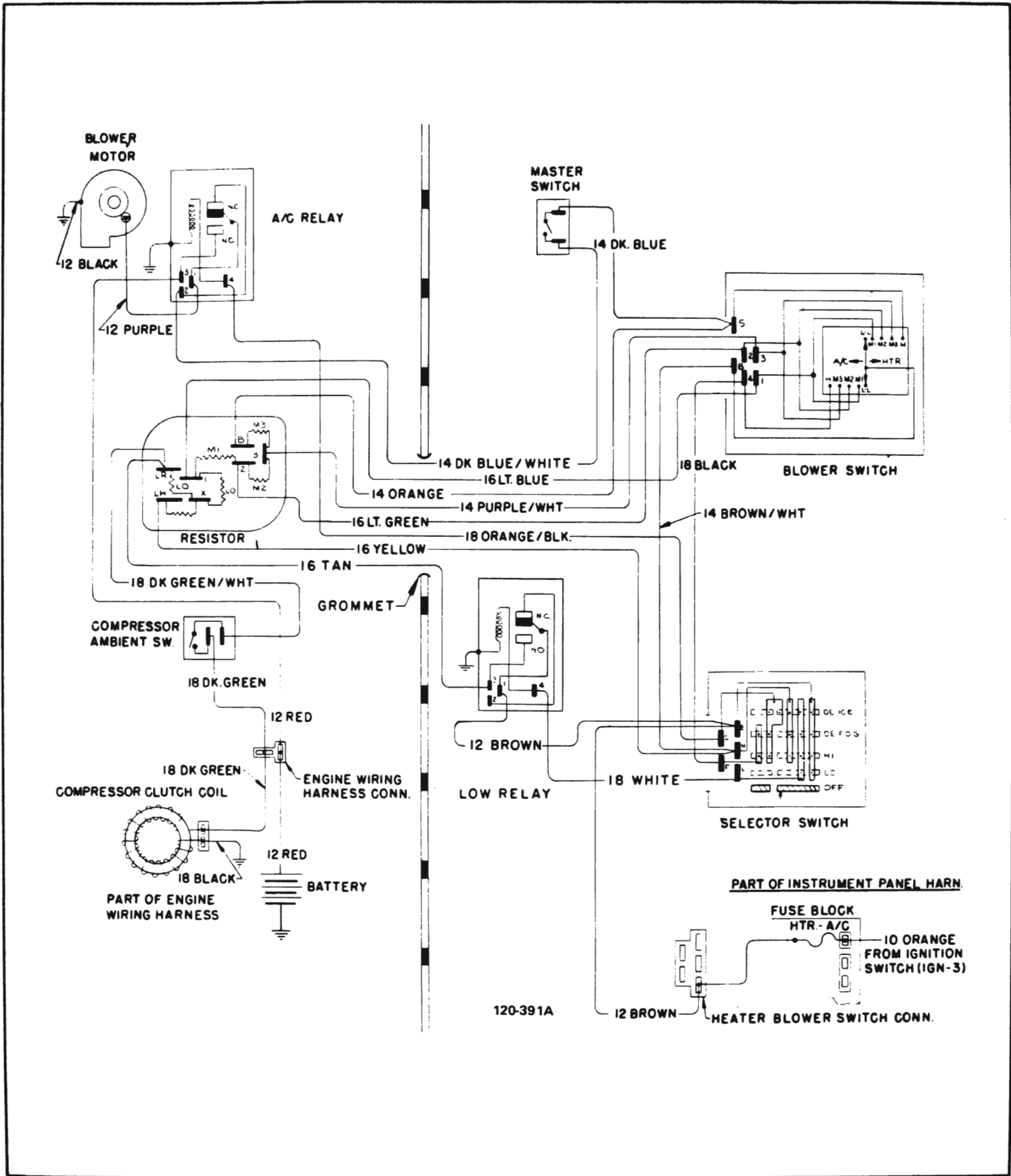

Figure I20-94 Automatic Air Conditioner Wiring Diagram - LeSabre, Wildcat and Electra

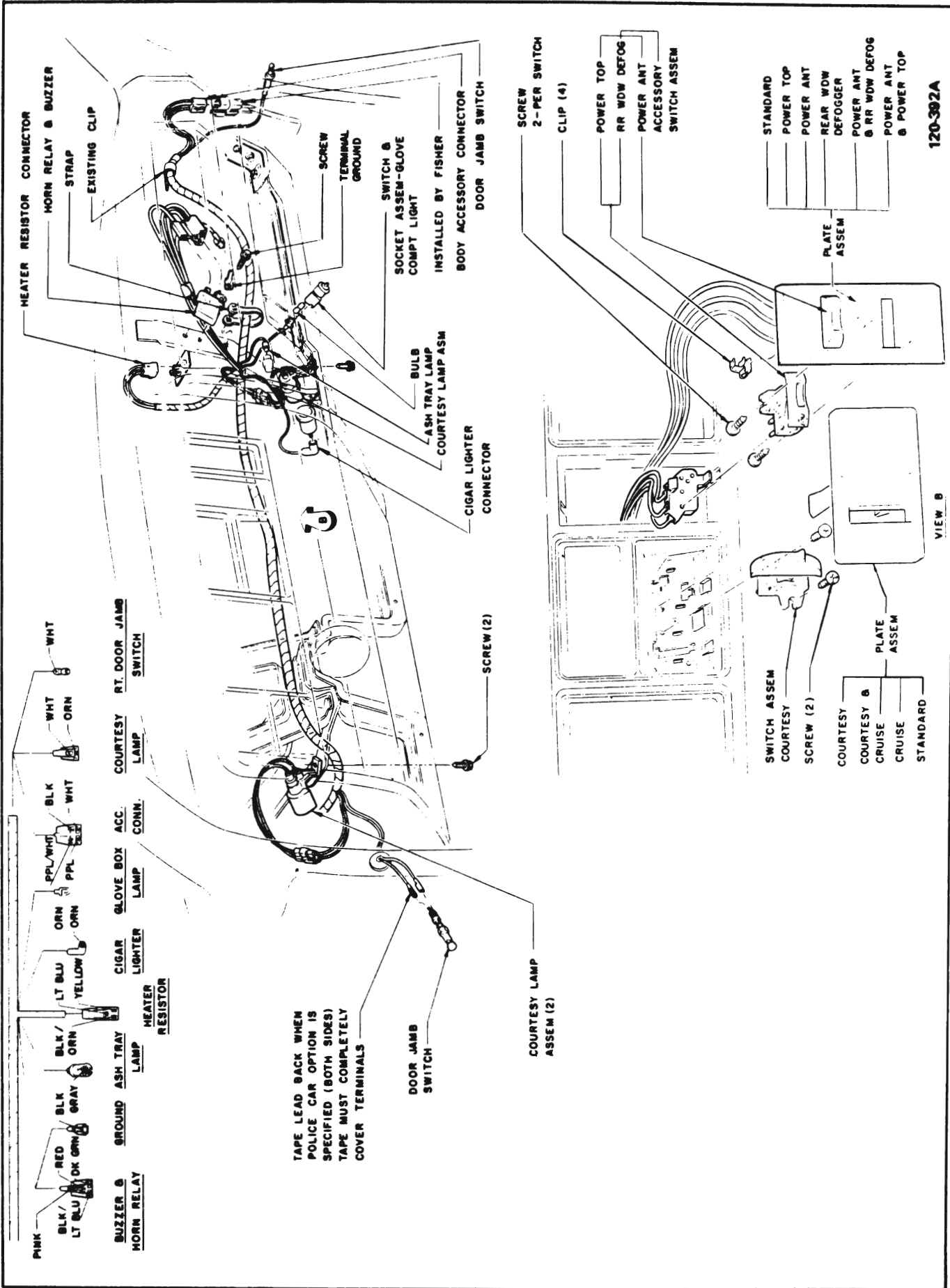

Figure 120-95 Automatic Air Conditioner Wiring - LeSabre, Wildcat and Electra

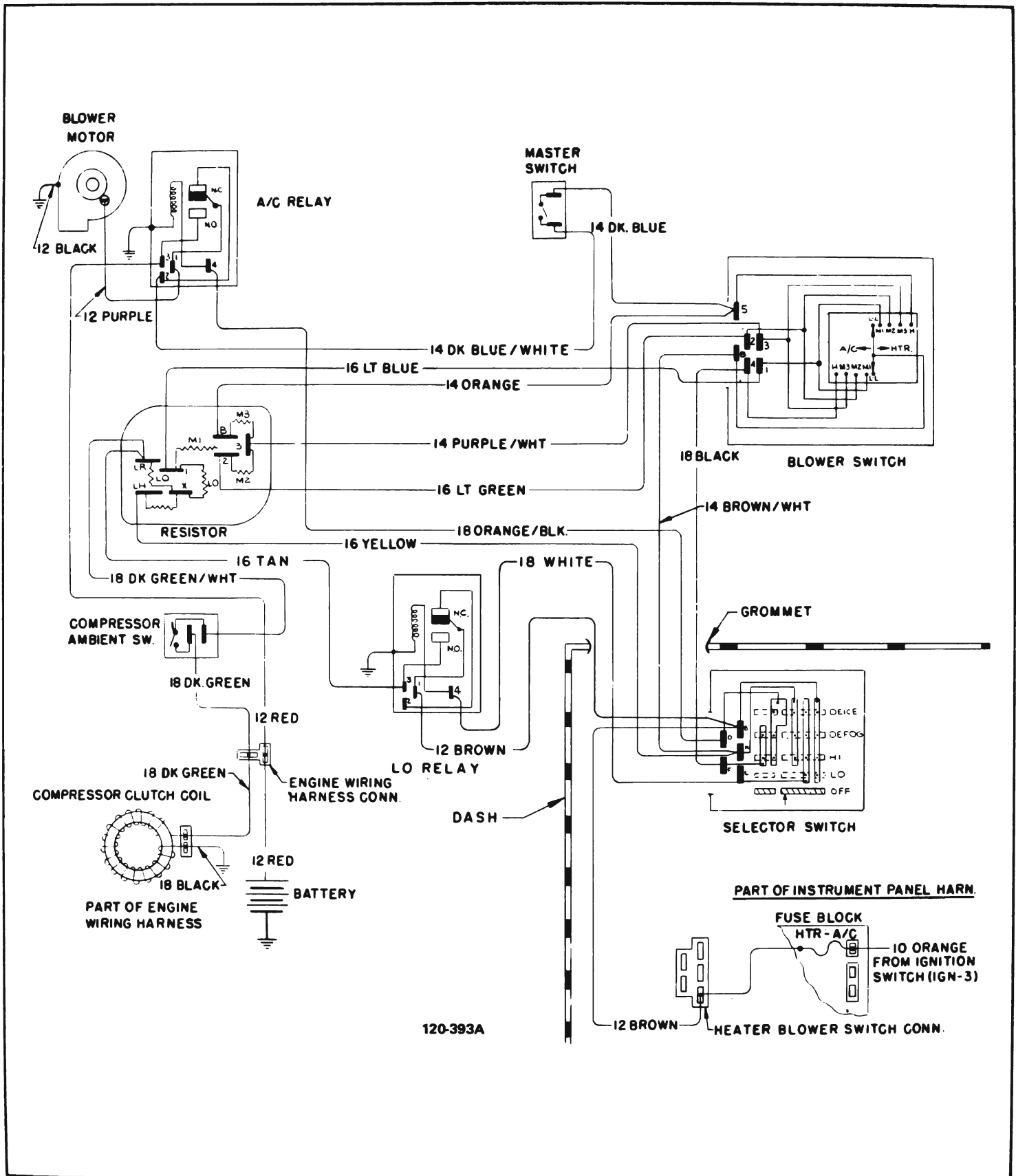

Figure 120-96 Automatic Air Conditioner Wiring Diagram - Riviera

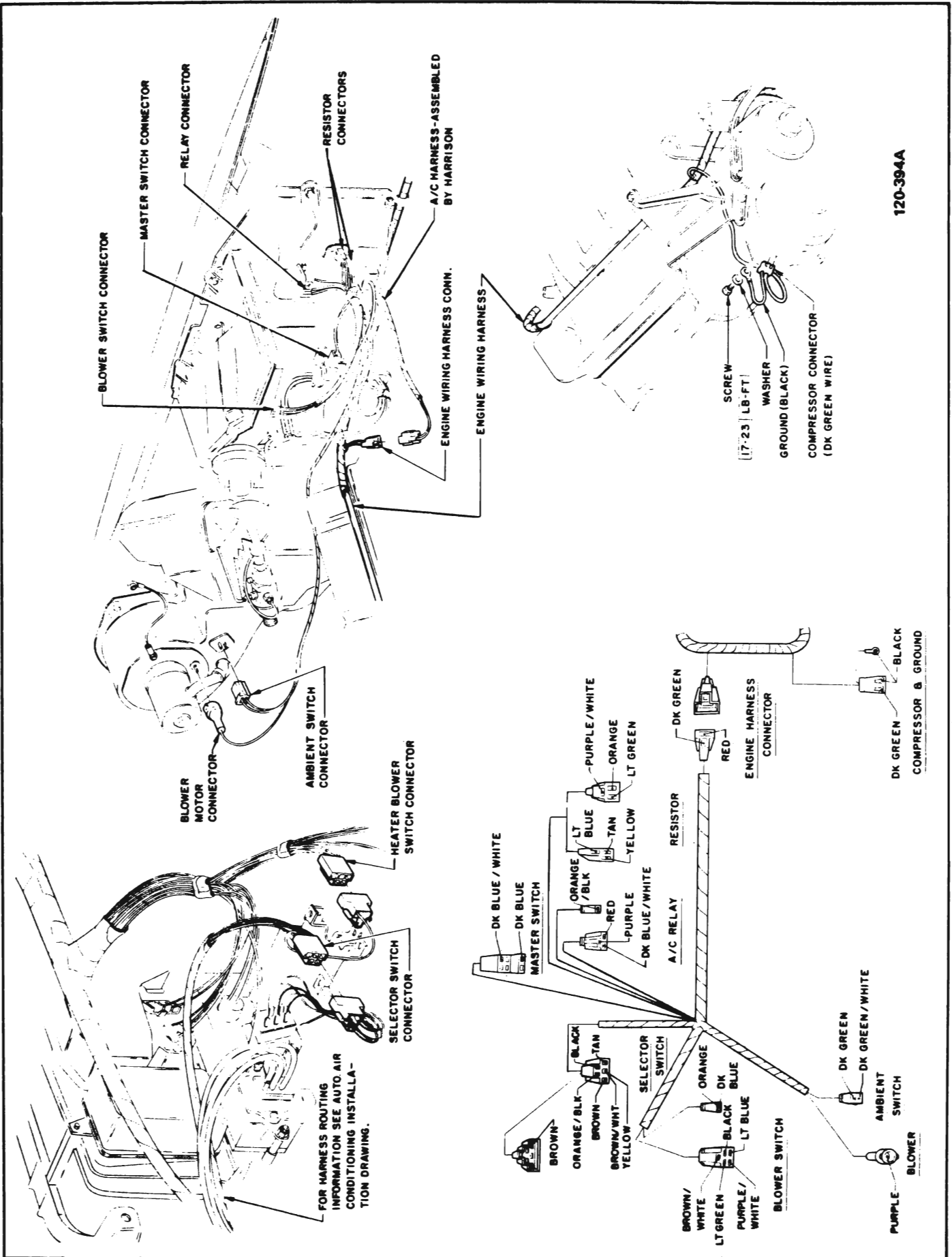

Figure 120-97 Automatic Air Conditioner Wiring - Riviera

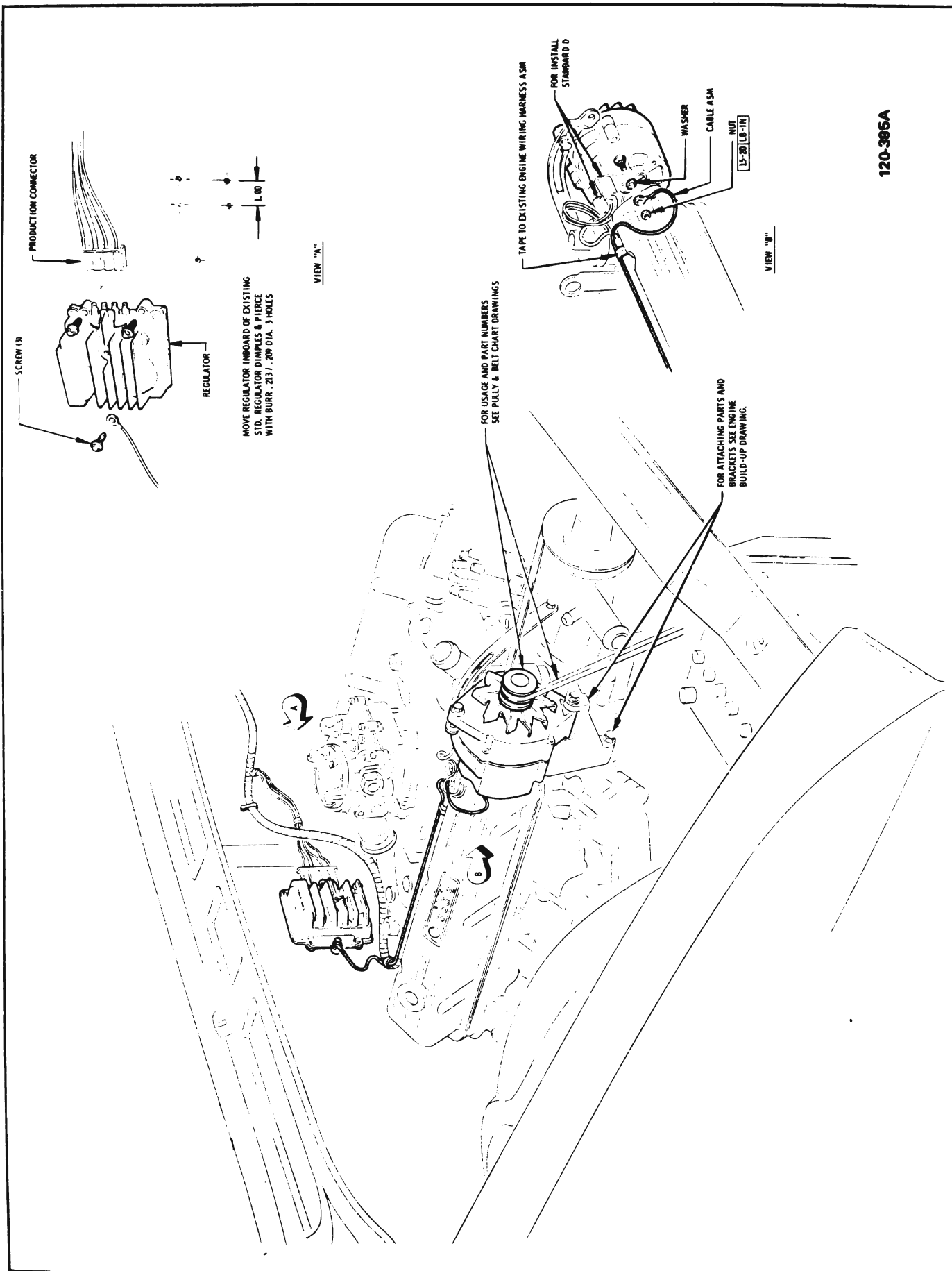

Figure 120-98 Police Generator Installation - Special Deluxe

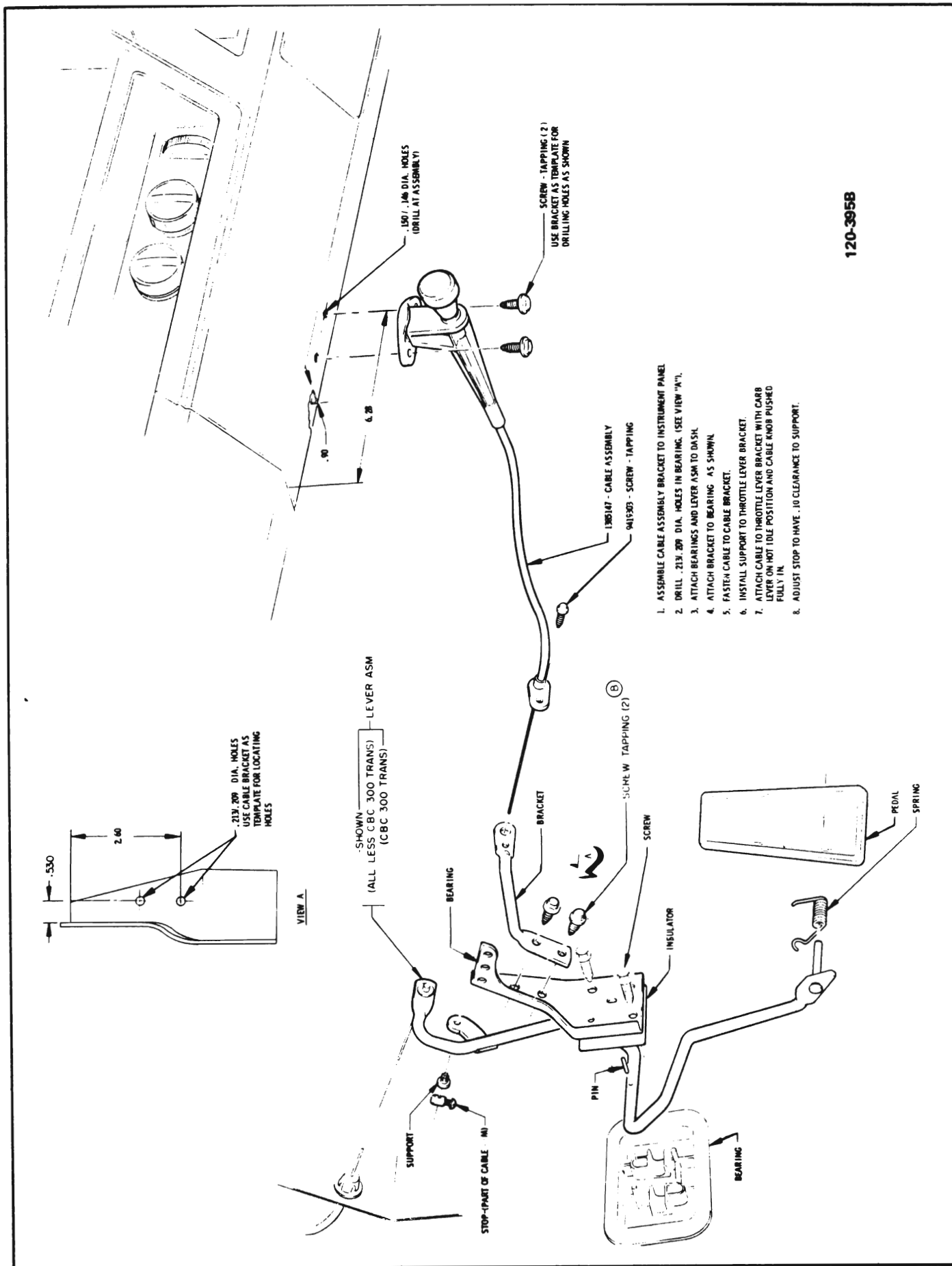

Figure 120-99 Police Hand Throttle - Special Deluxe

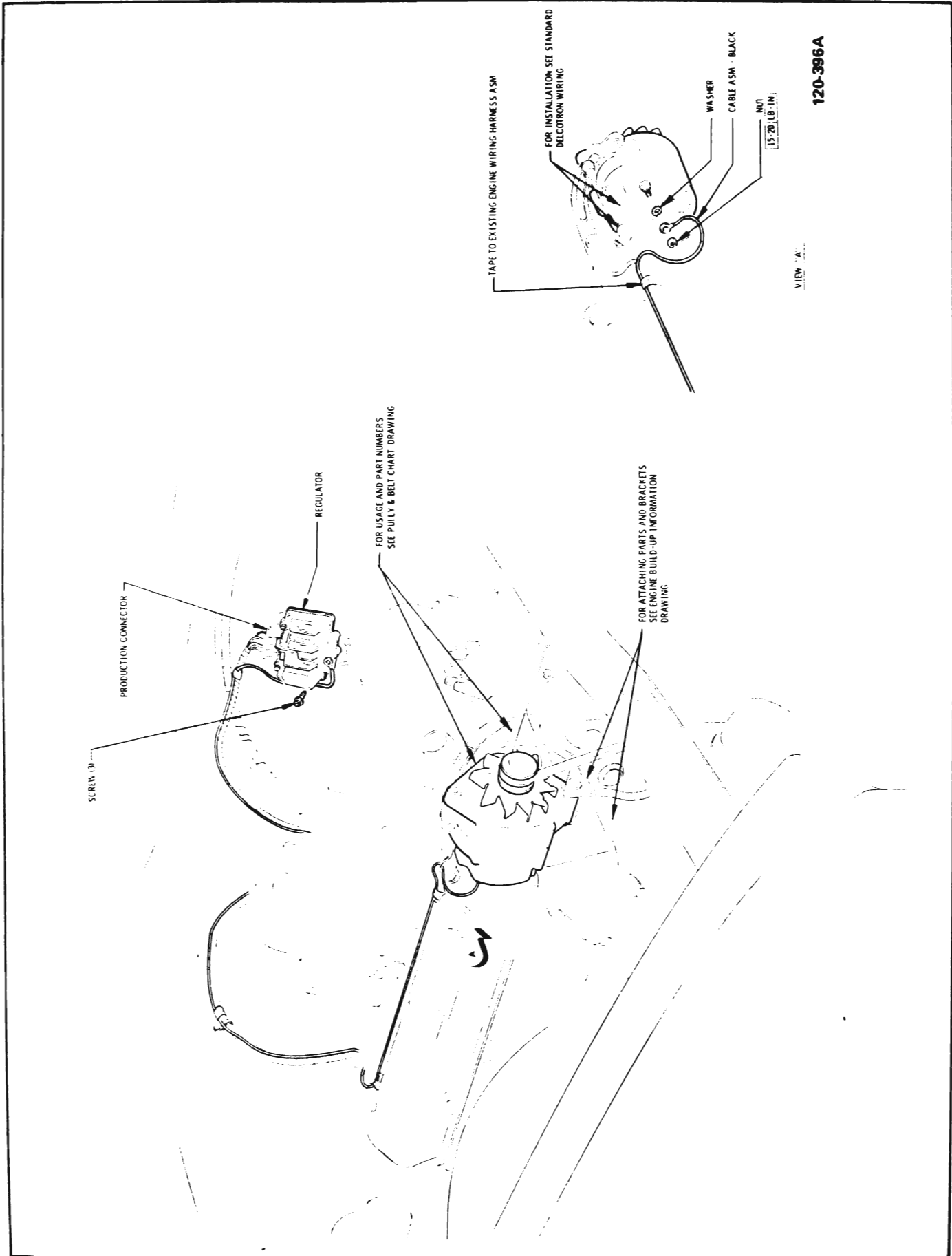

Figure 120-100 Police Generator
Installation - Wildcat

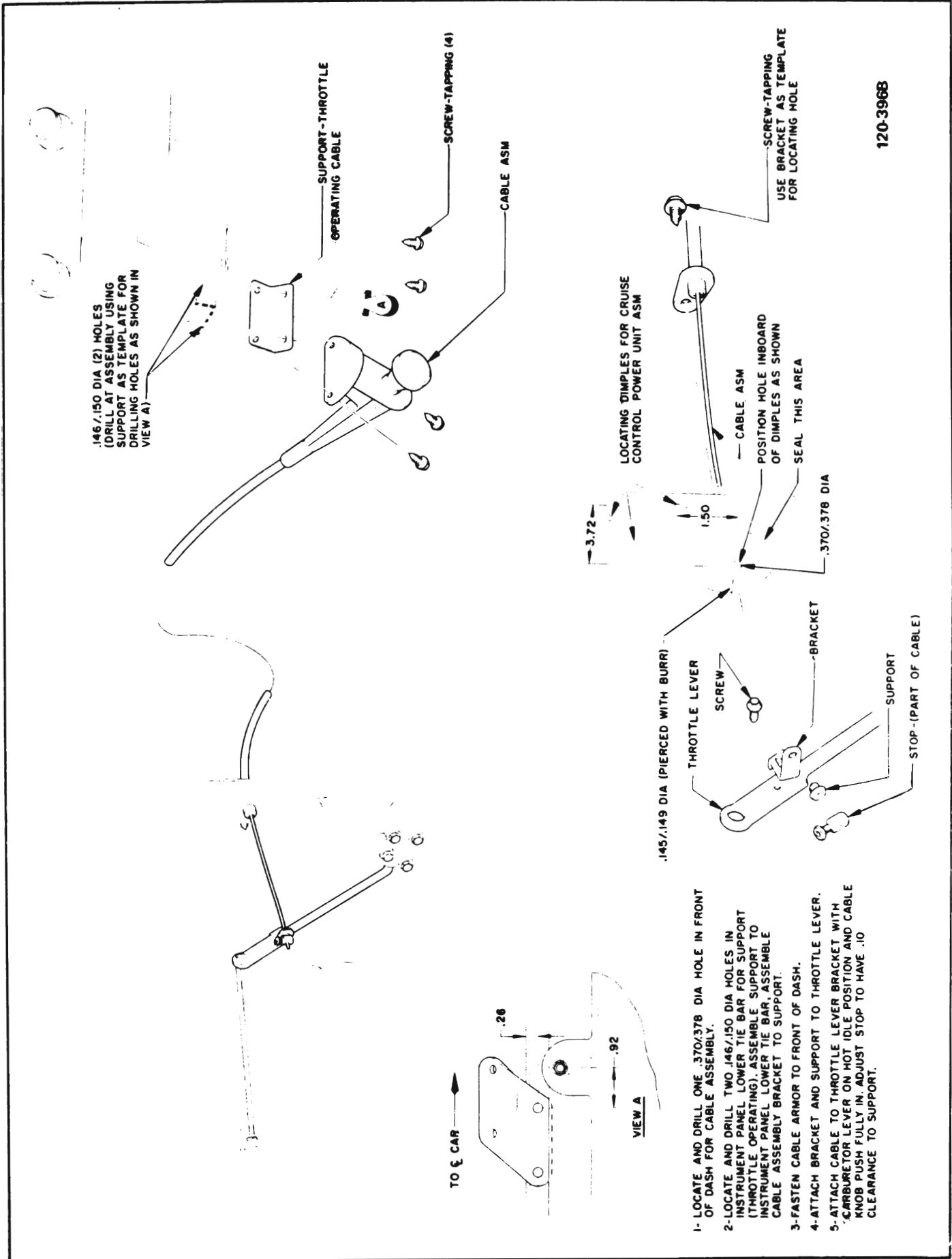
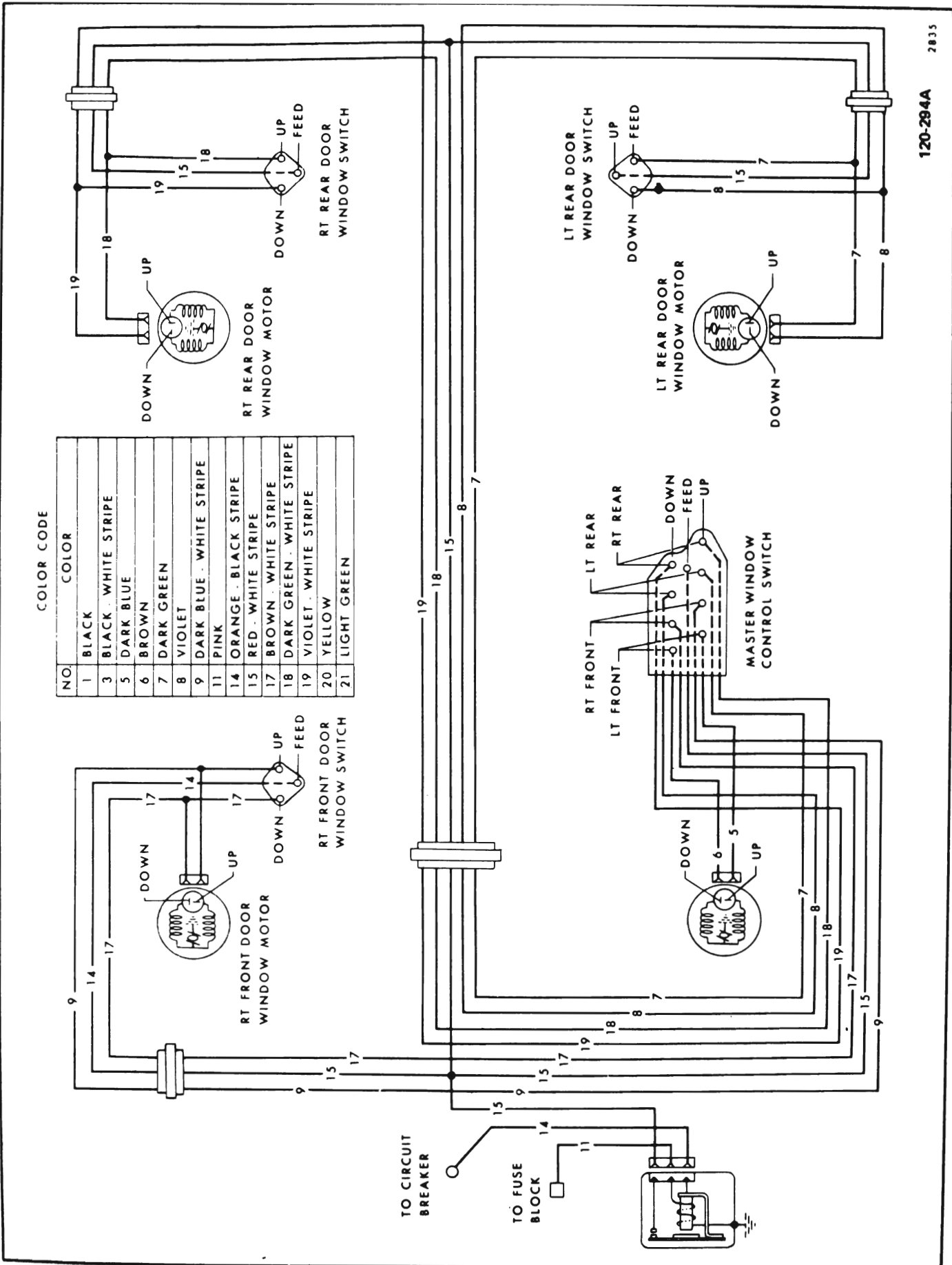

Figure 120 101 Police Hand Throttle
Wildcat



2835

120-294A

Figure 120-102 Power Window
Wiring Diagram - 43-44000

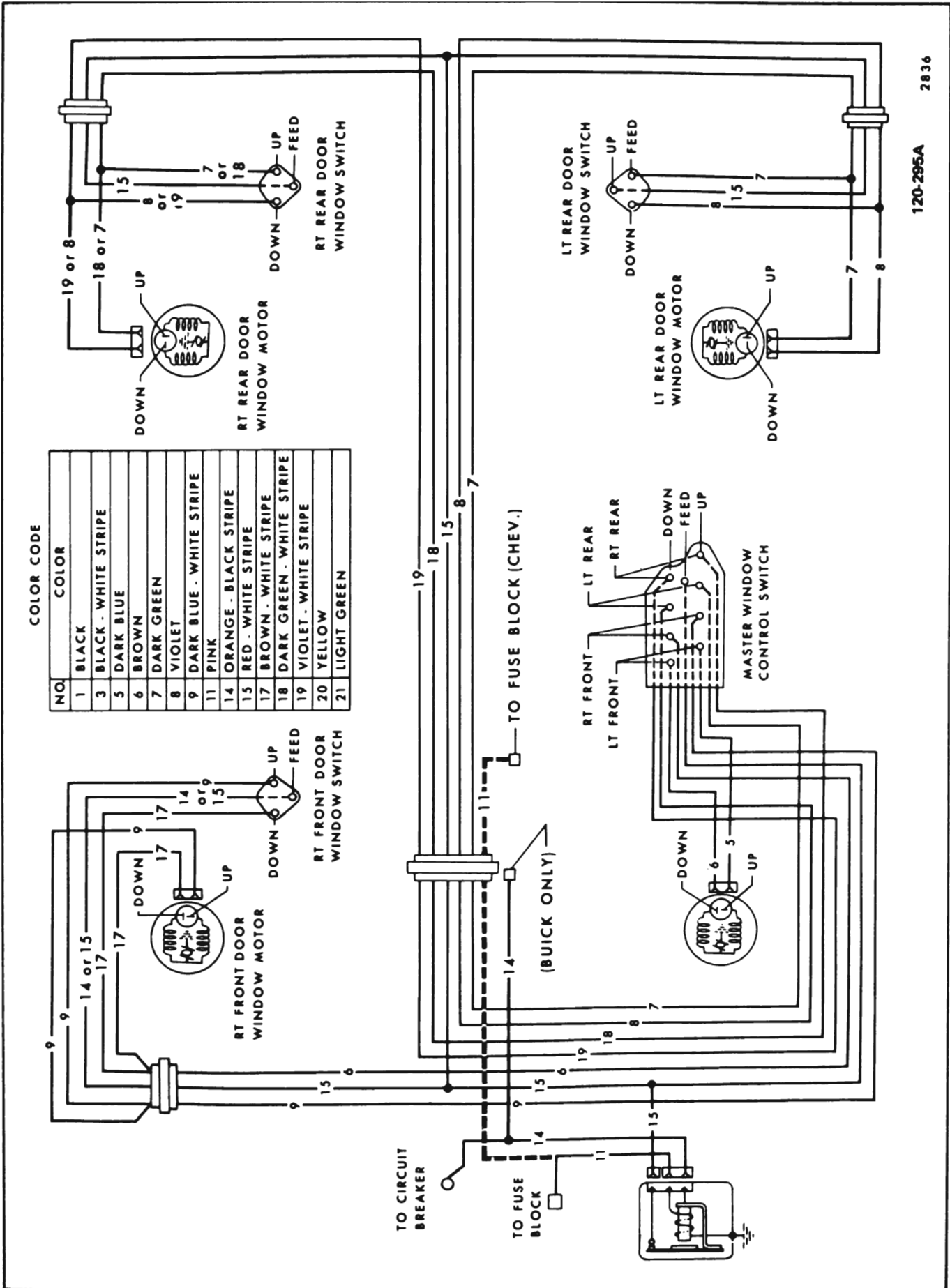

Figure 120-103 Power Window Wiring Diagram - LeSabre, Wildcat and Electra

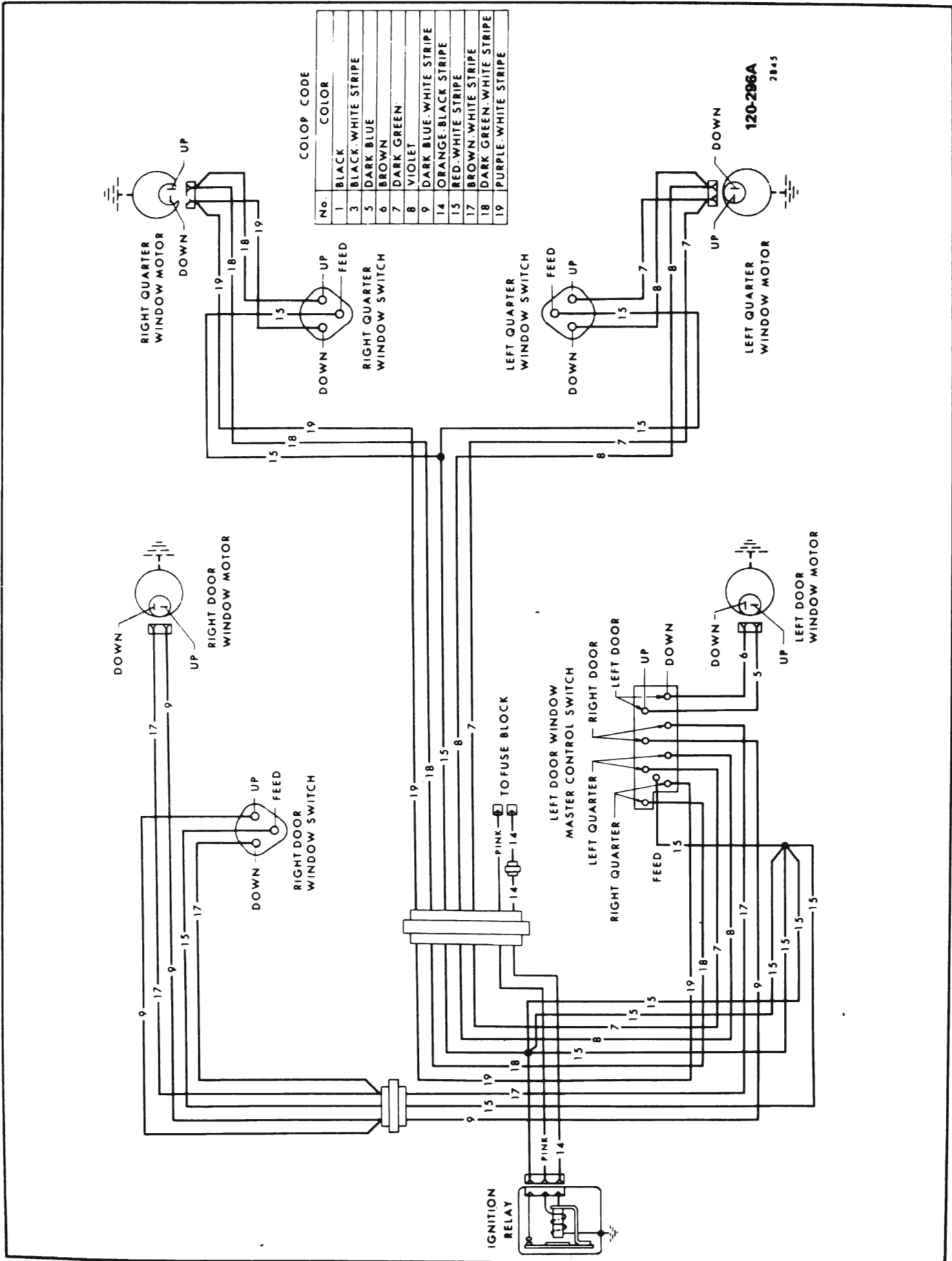

Figure 120-104 Power Window Wiring Diagram - Riviera

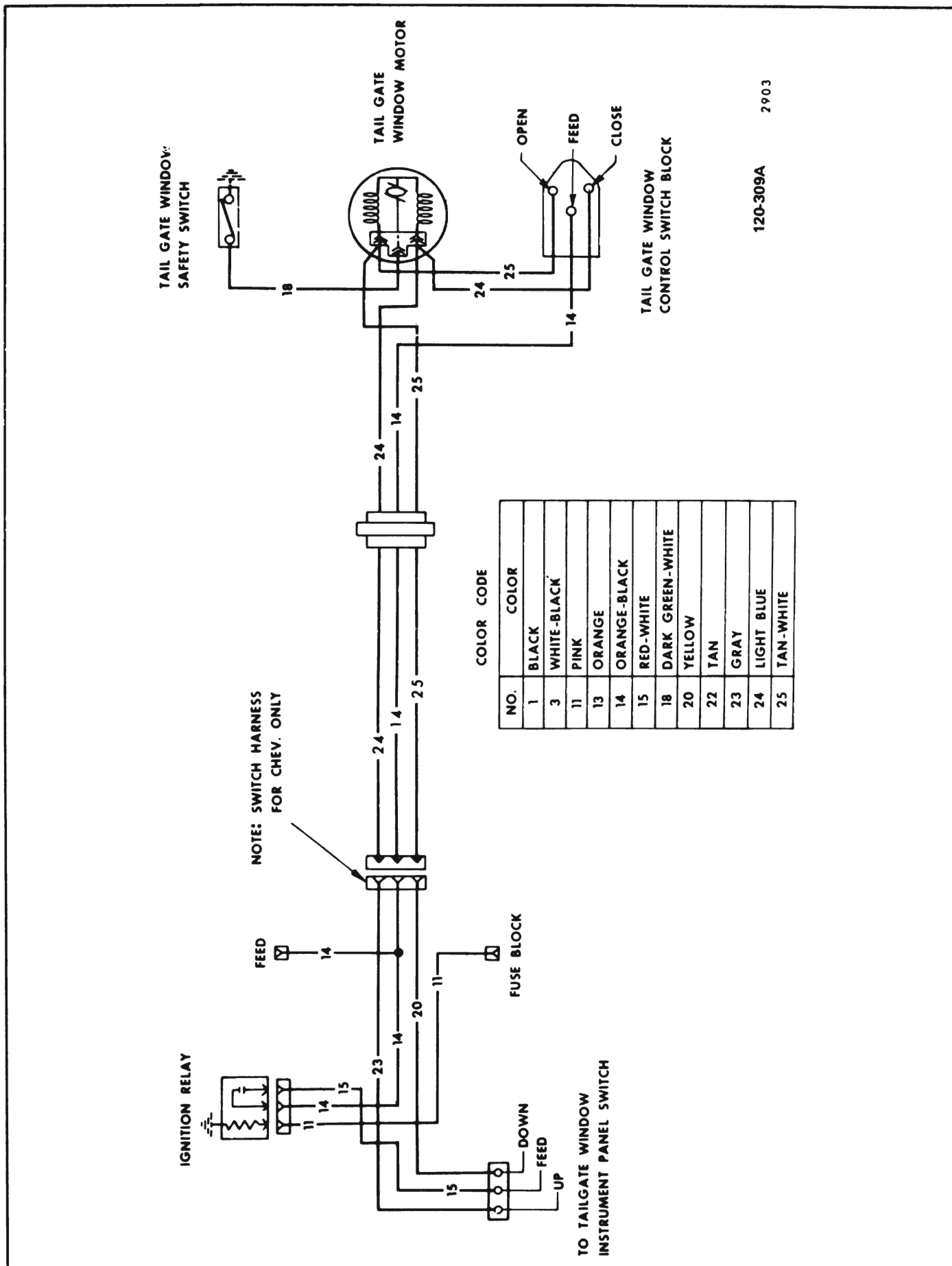

Figure 120-105 Power Tailgate Window Wiring Diagram

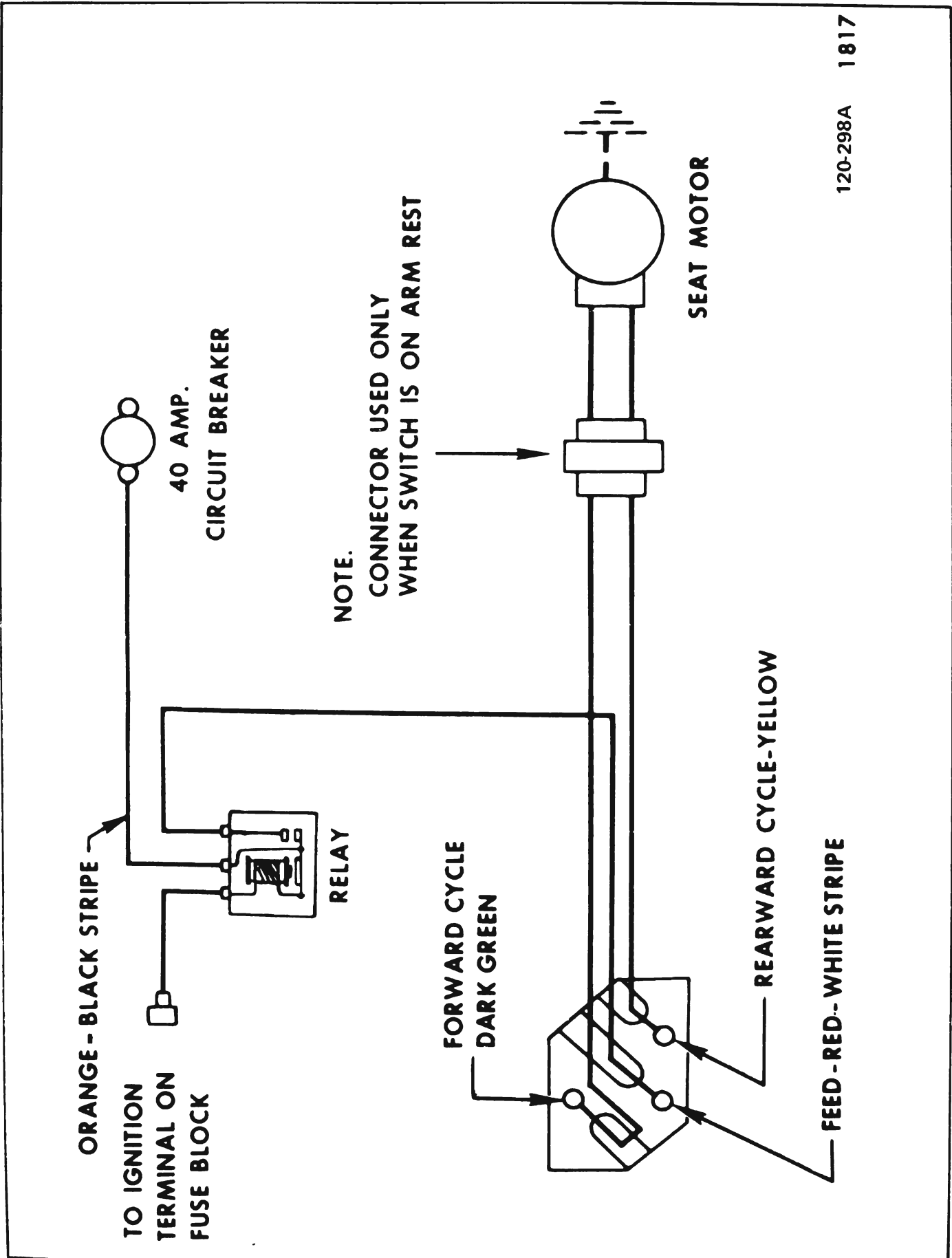
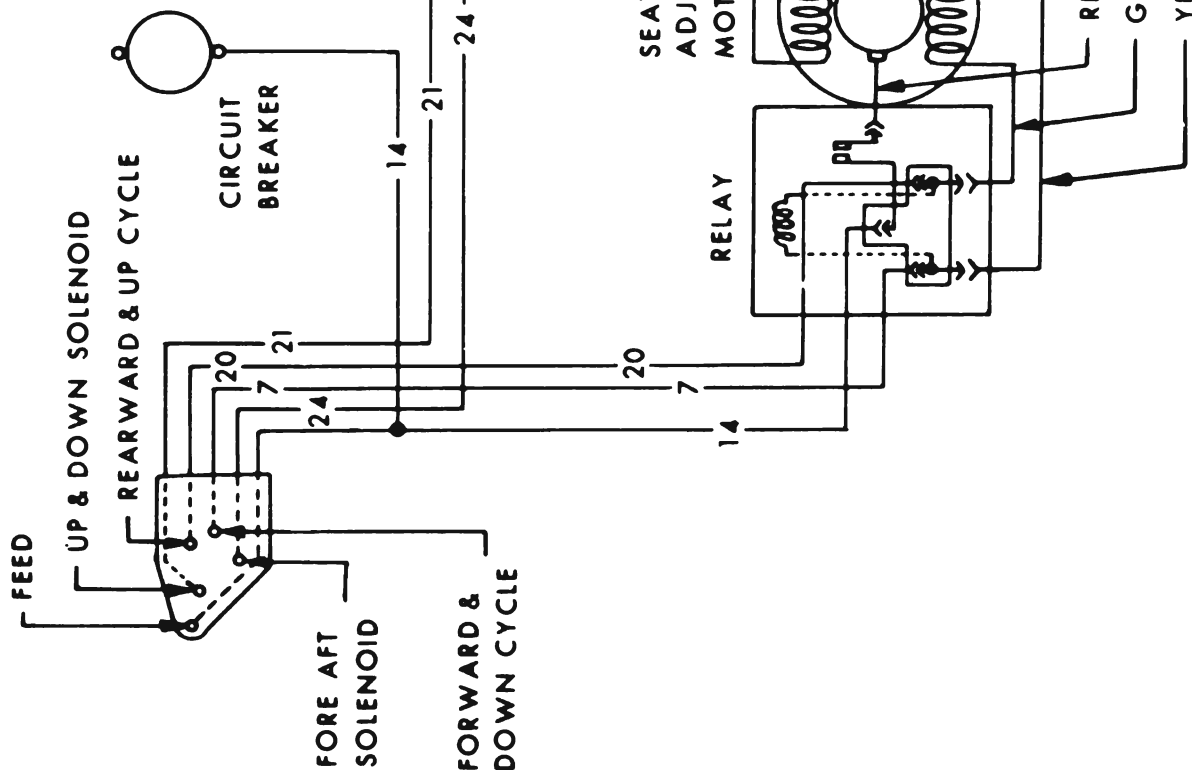

Figure 120-106 Two-Way Power Seat
Wiring Diagram

WIRE IDENTIFICATION	
No.	FUNCTION
7	FIELD FEED-FORWARD & DOWN CYCLE
14	FIELD FEED-REARWARD & UP CYCLE
20	FIELD FEED-REARWARD & UP CYCLE
21	SOLENOID-VERTICAL MOVEMENT
24	SOLENOID-HORIZONTAL MOVEMENT



120-298B

1493

Figure 120-107 Four-Way Power
Seat Wiring Diagram

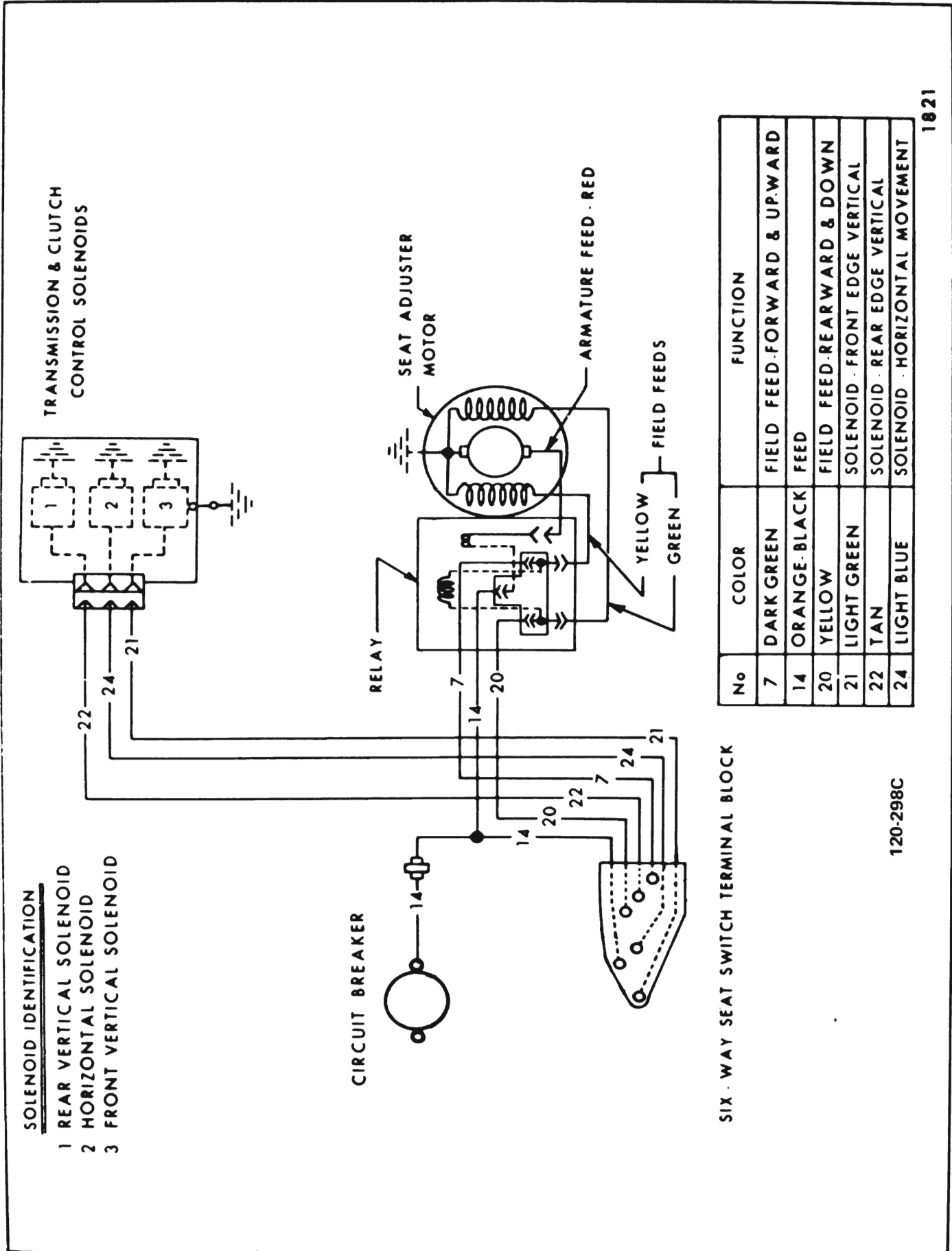
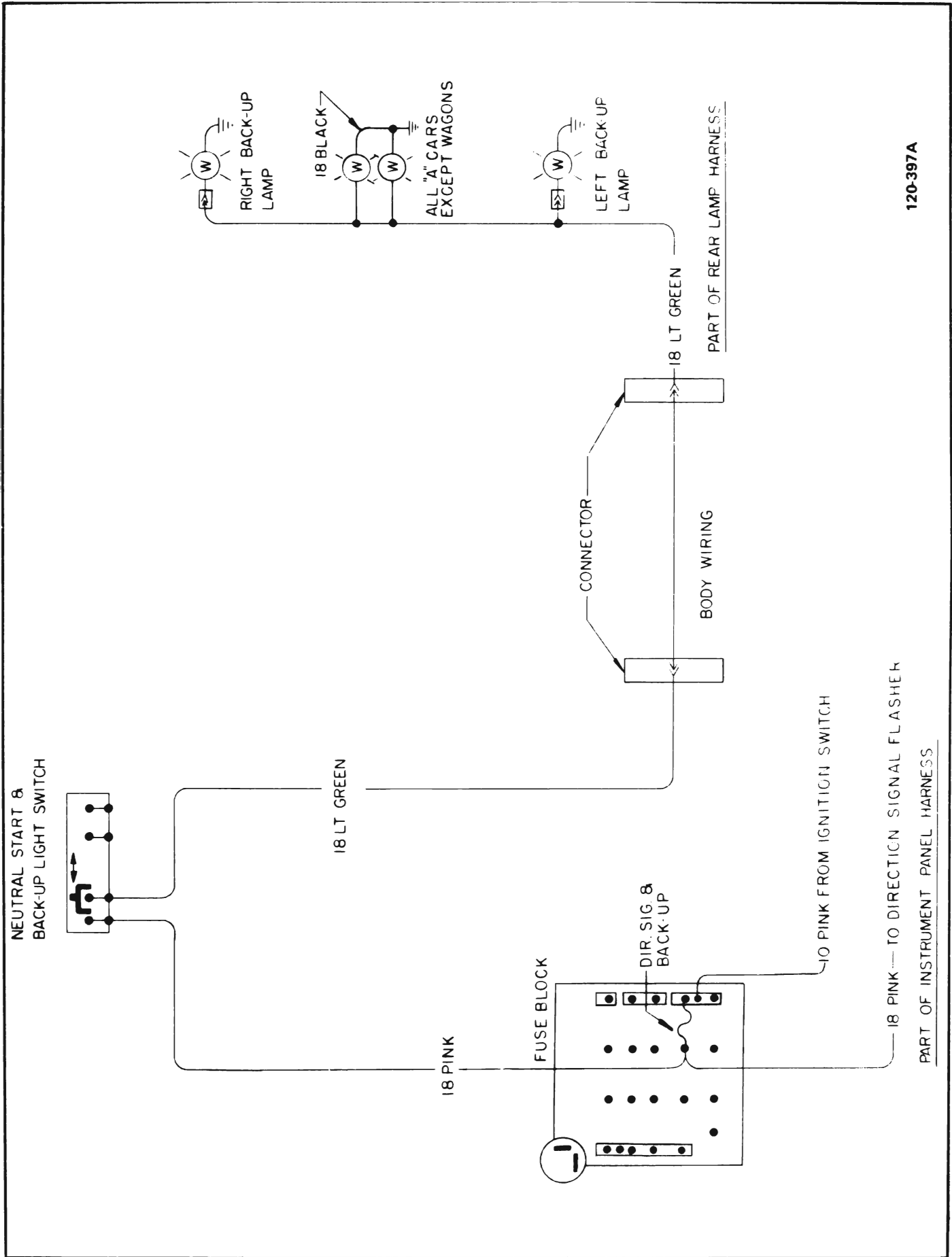

Figure 120-108 Six-Way Power Seat Wiring Diagram



120-397A

Figure 120-109 Back-Up Light Wiring Diagram

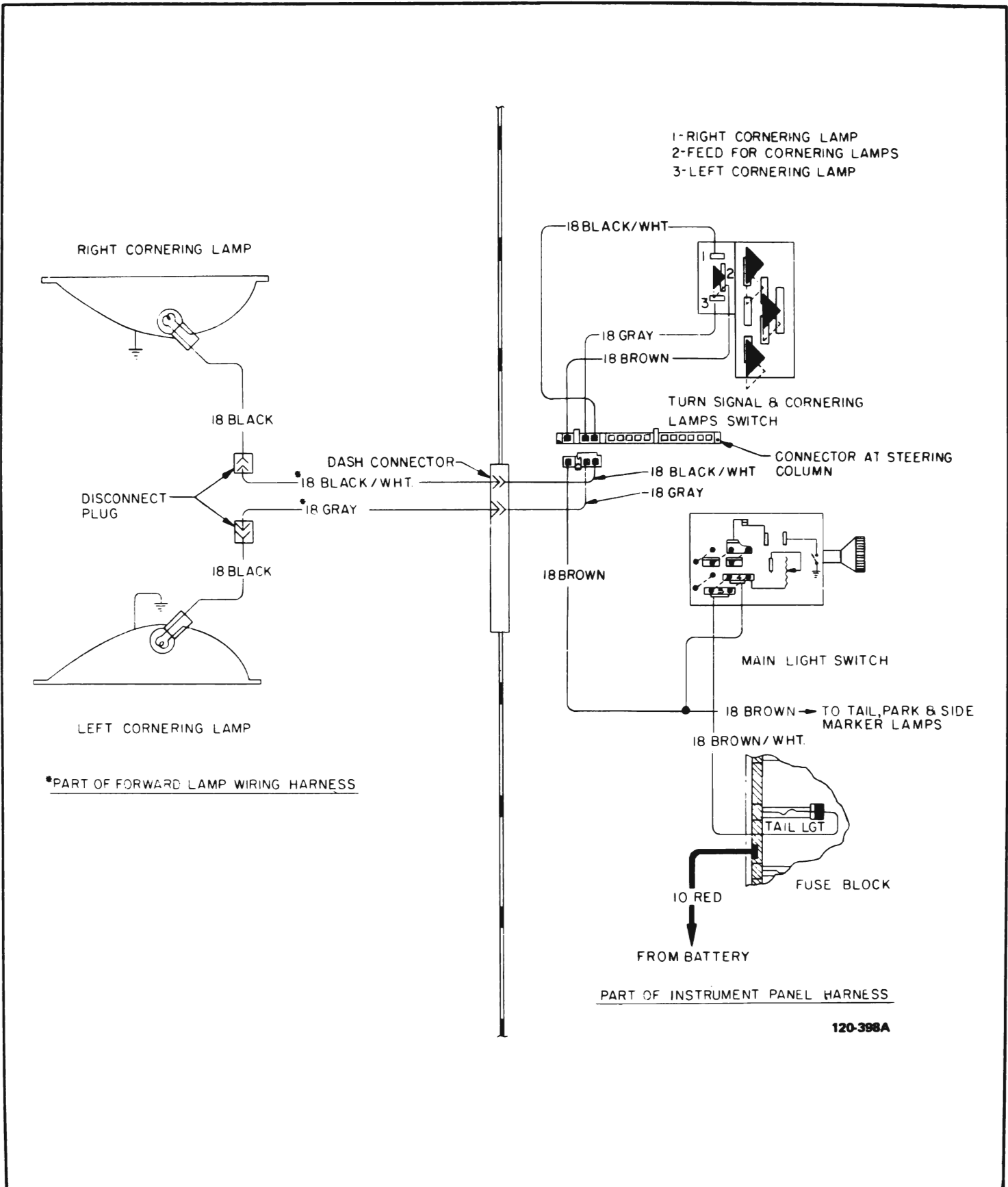

Figure 120-110 Cornering Light Wiring Diagram

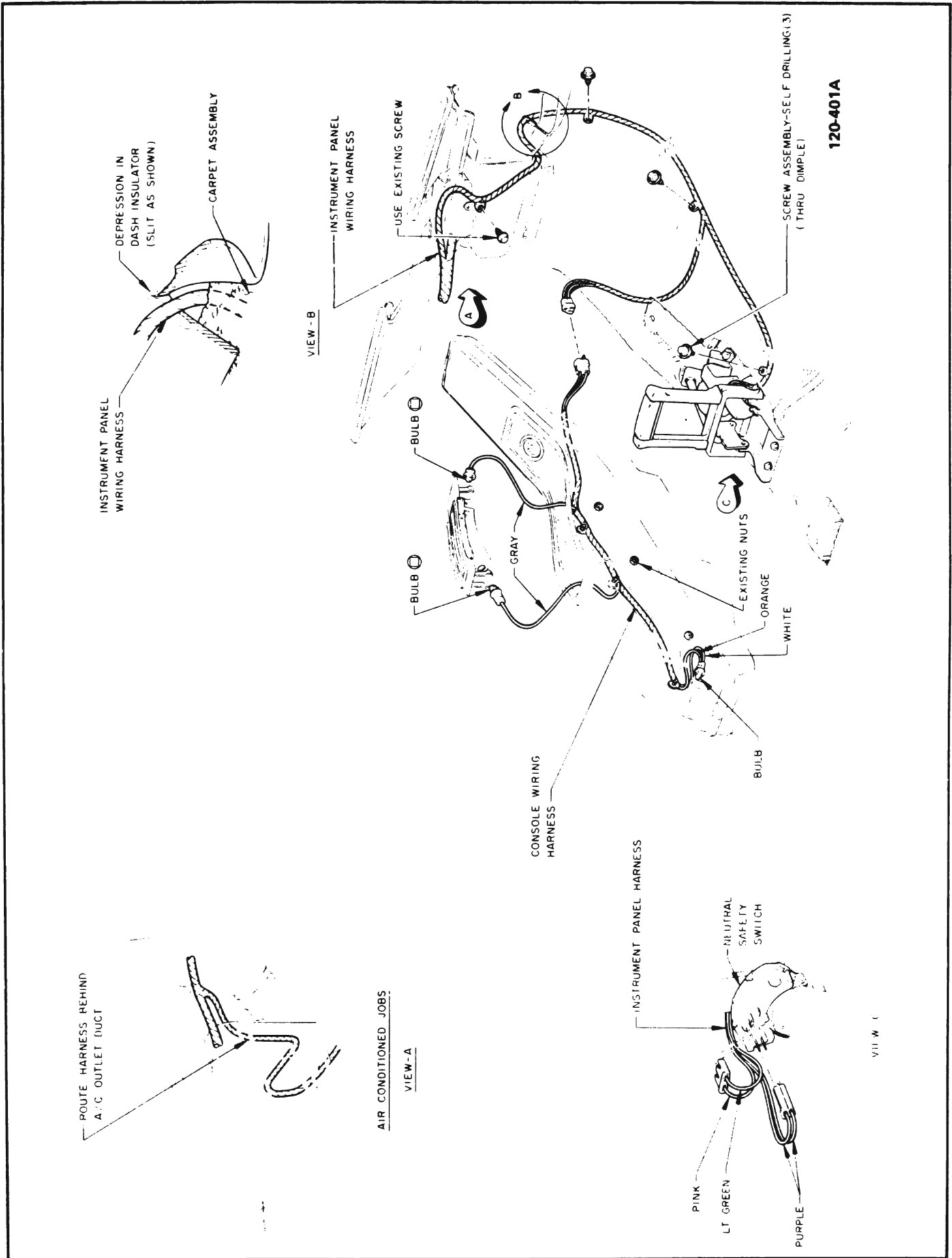

Figure 120-III Console Wiring
43-44000

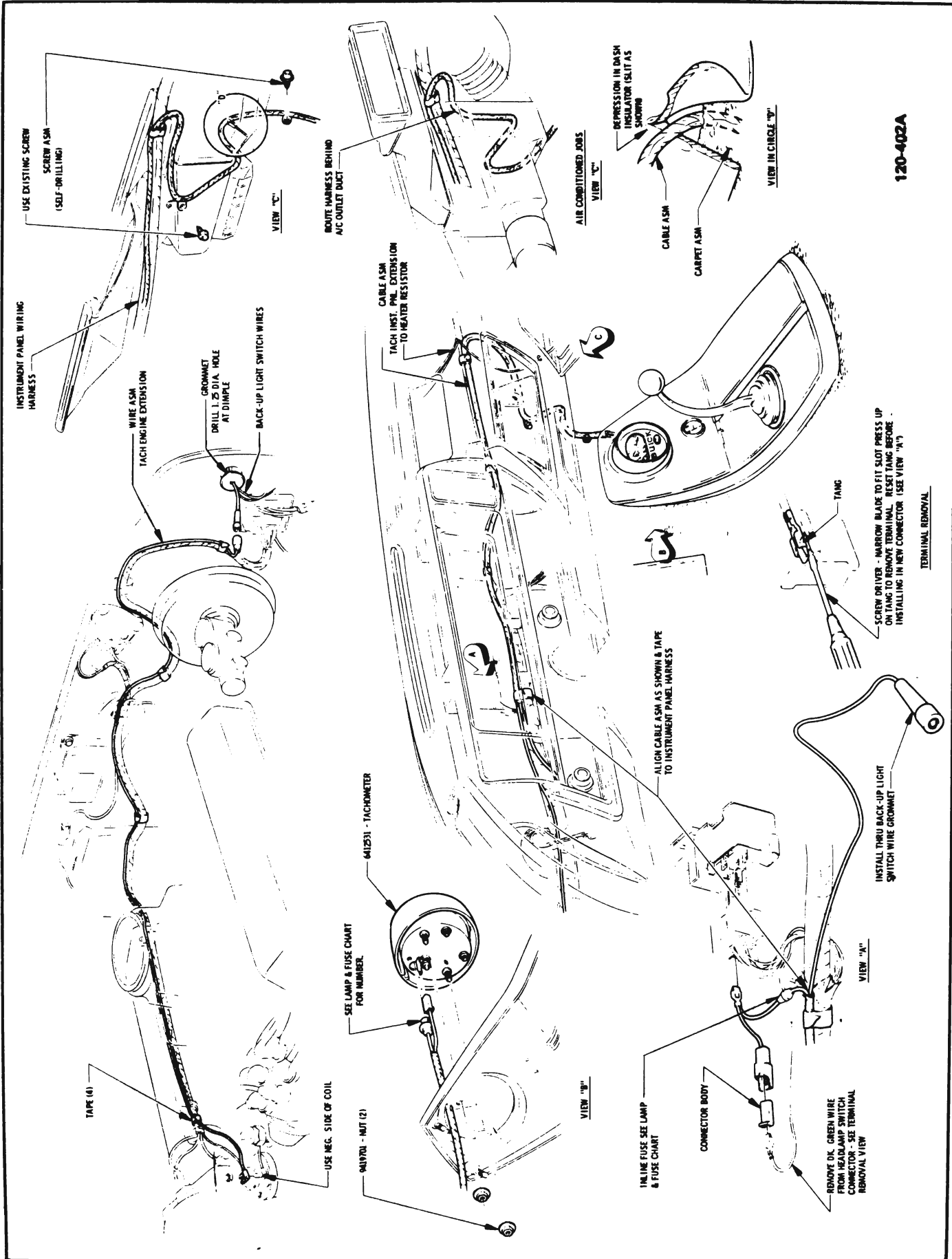
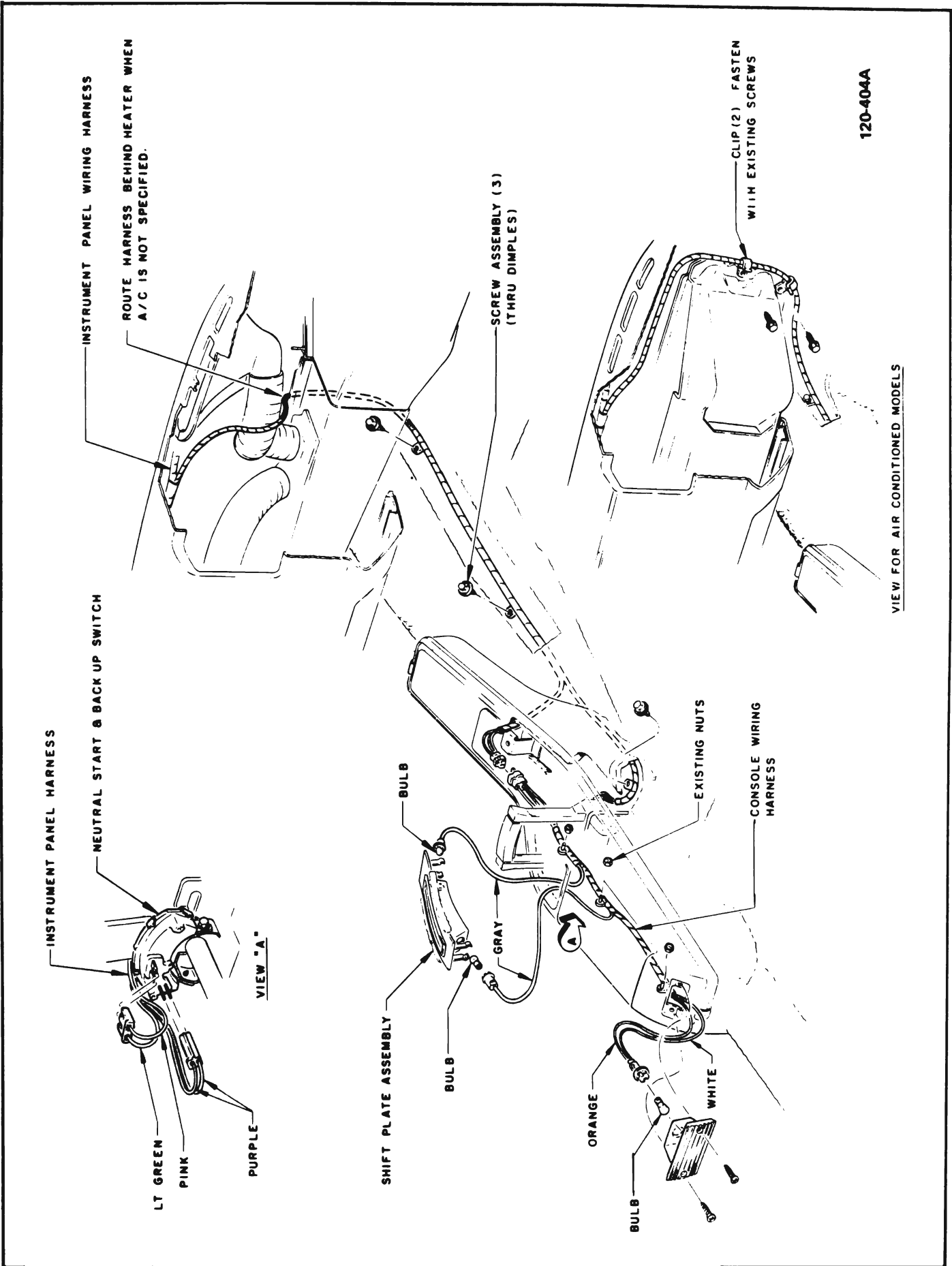

Figure 120-112 Tachometer Wiring - 43-44000



120-404A

Figure 120-113 Console Wiring - Wildcat

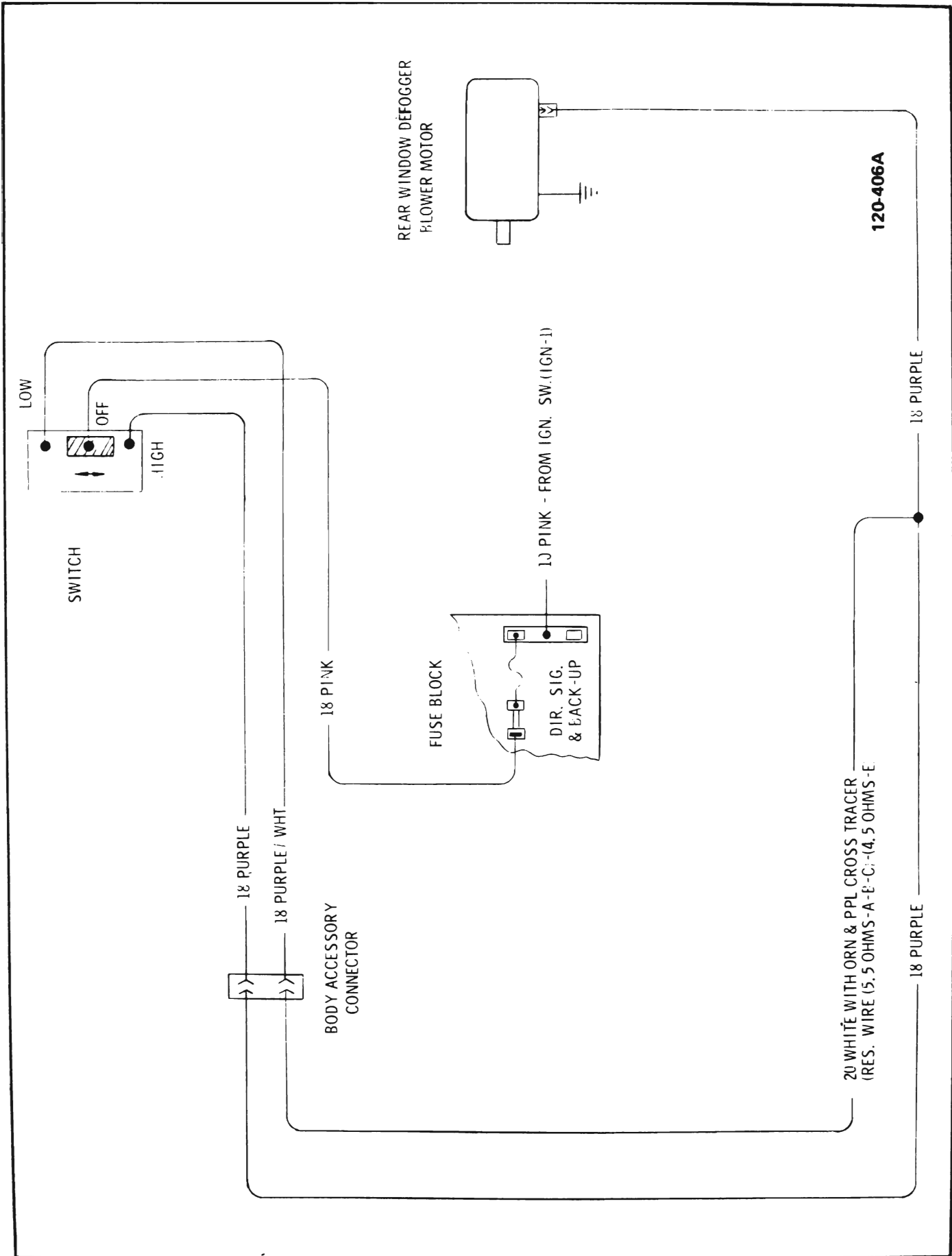

Figure 120-114 Rear Window Defroster Wiring Diagram

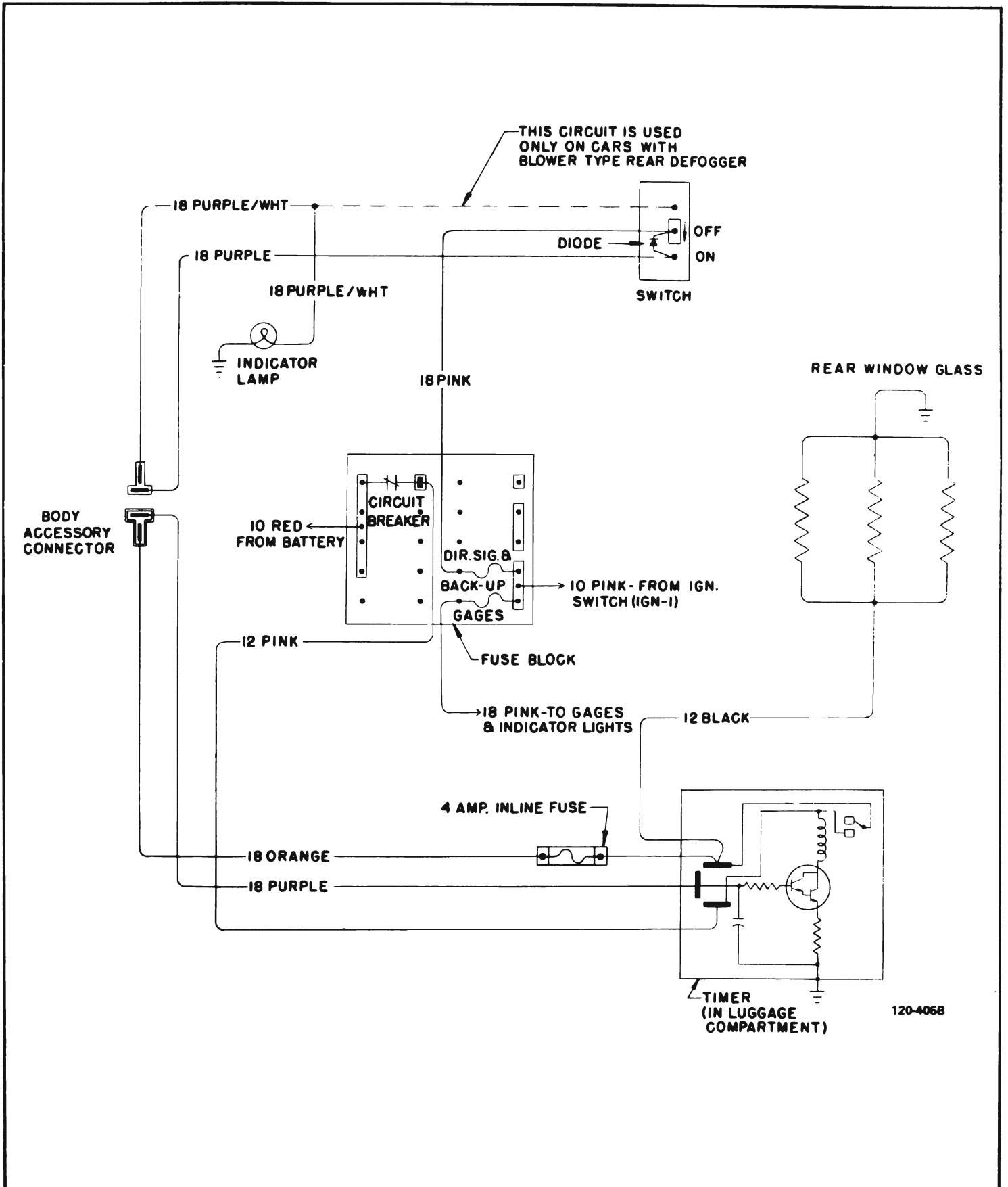

Figure I20-115 Electrically Heated Rear Window Glass - Riviera

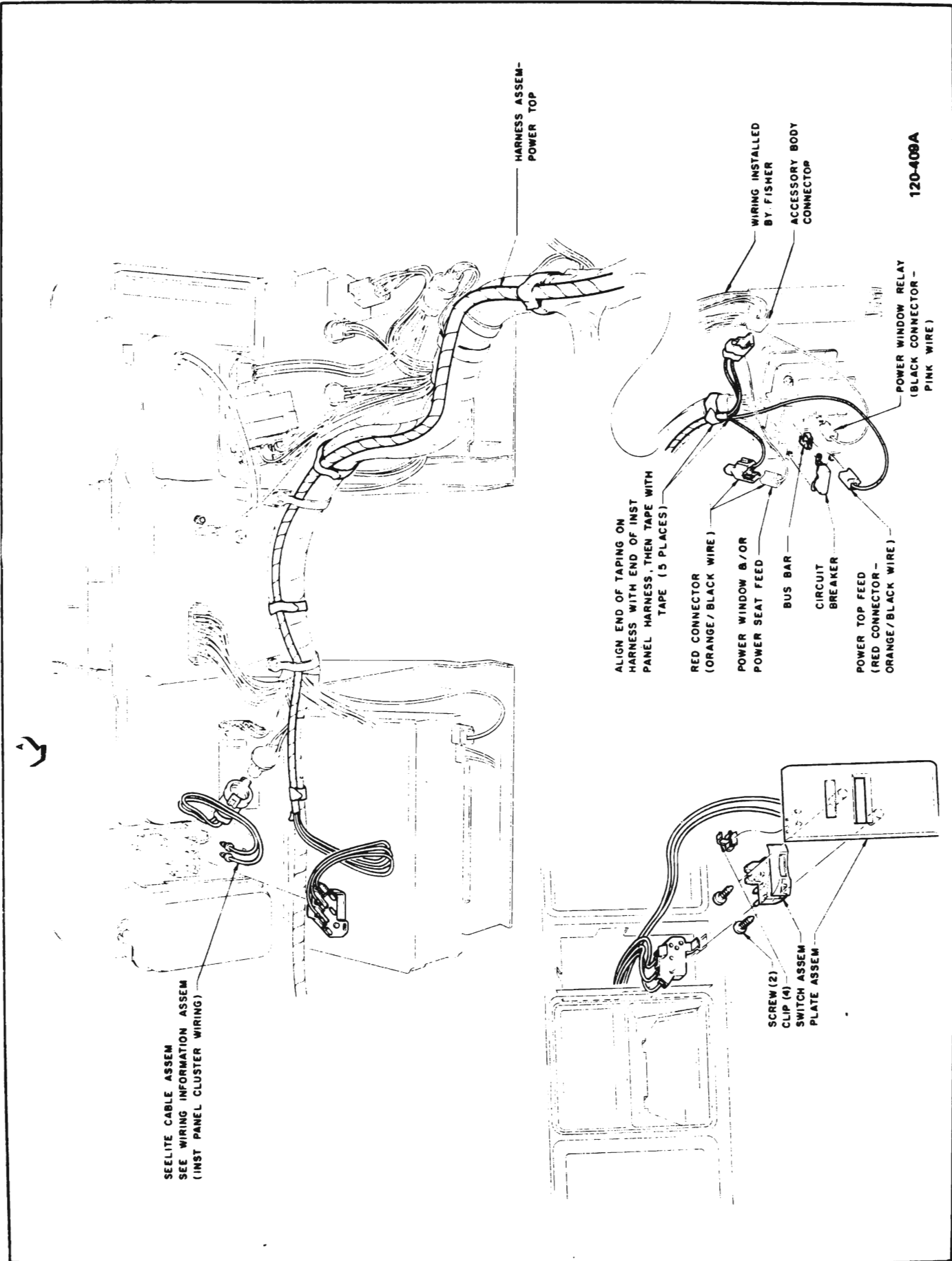

Figure 120-116 Power Top Wiring -
LeSabre, Wildcat and Electra

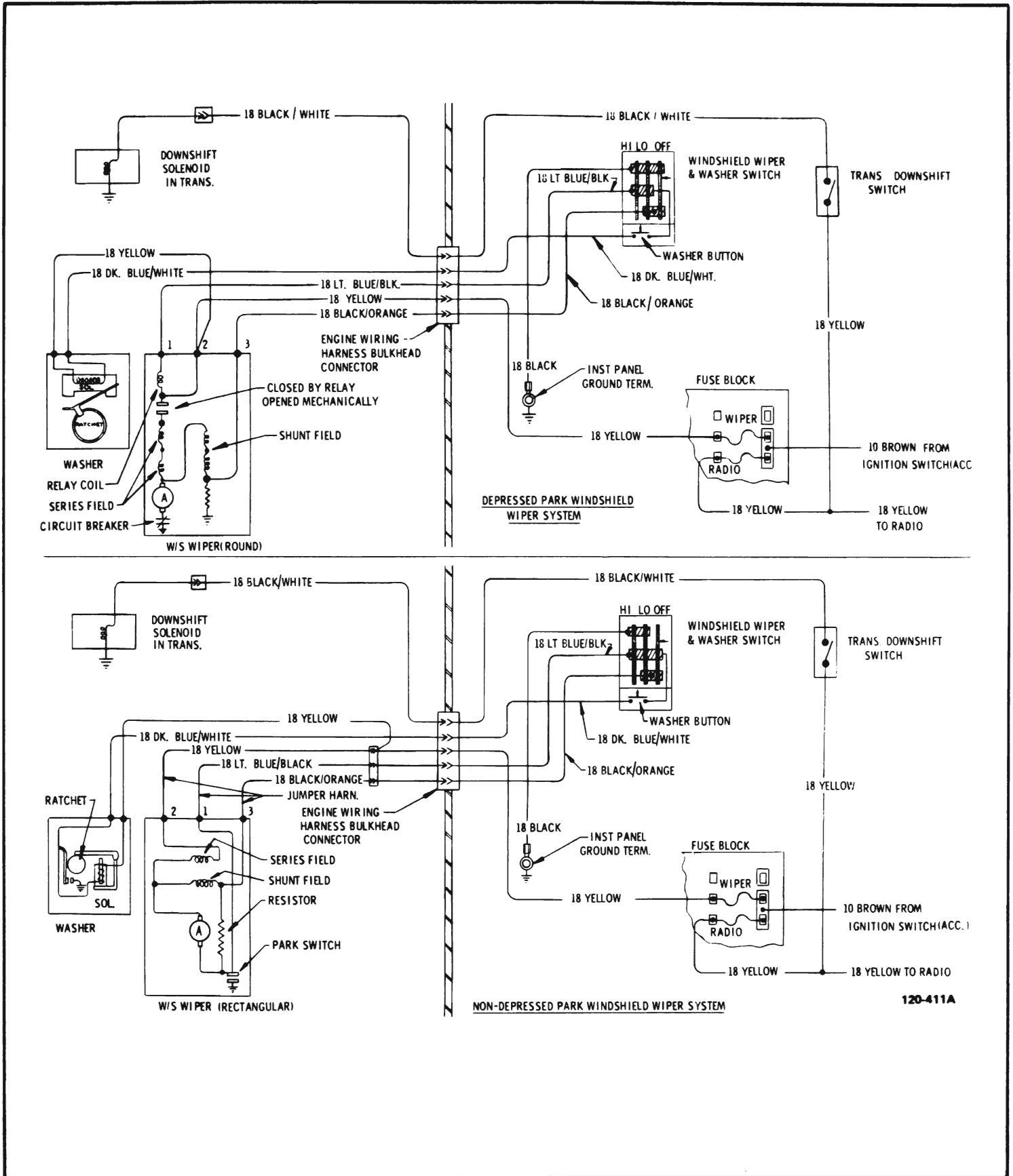
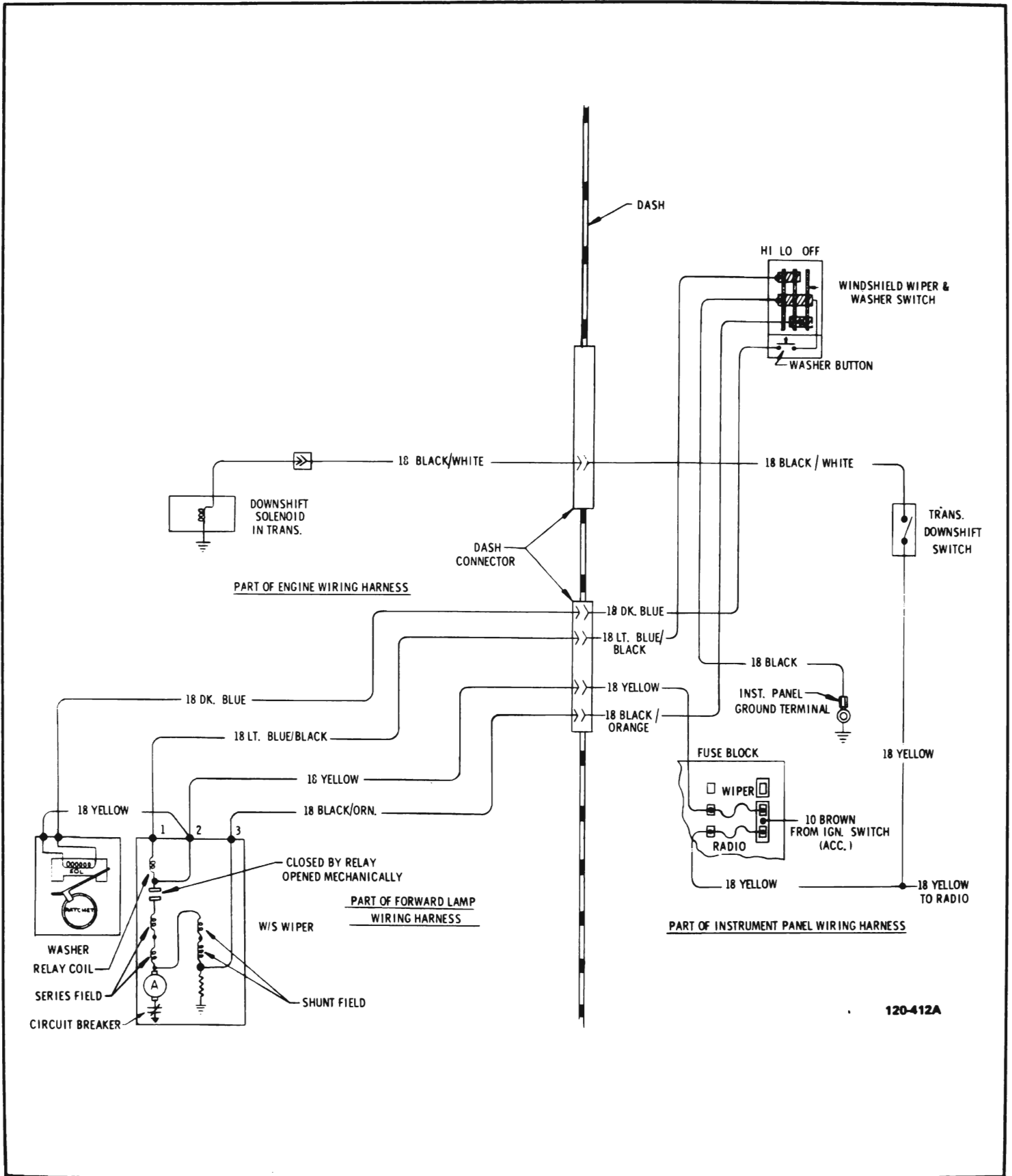

Figure I20-117 Wiper and Transmission Downshift Switch Wiring Diagram - 43-44000

120-411A



120-412A

Figure I20-118 Wiper and Transmission Downshift Switch Wiring Diagram - LeSabre, Wildcat, Electra and Riviera

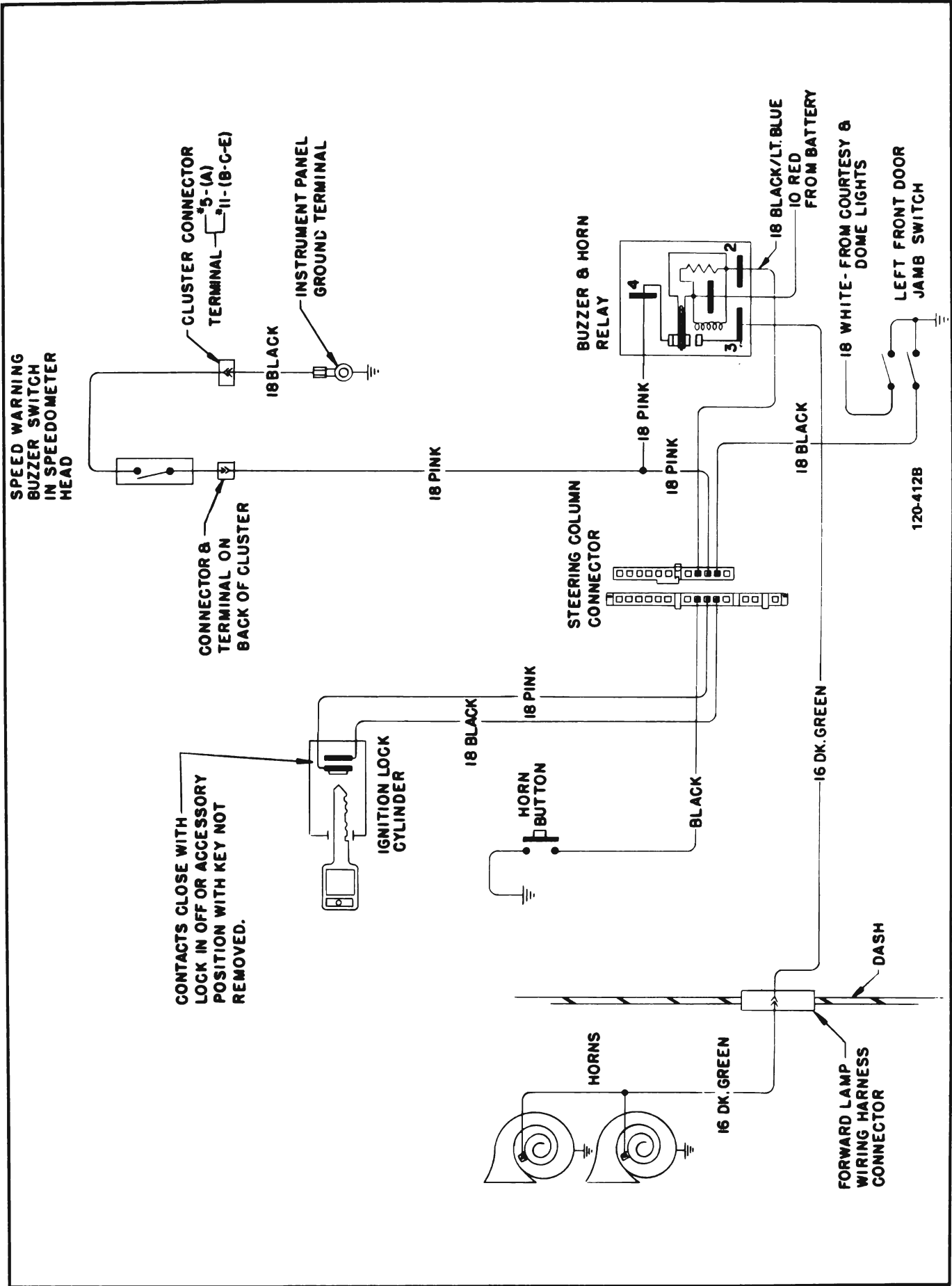

Figure 120-119 Horn Relay, Speedometer and Ignition Key Buzzer Wiring Diagram

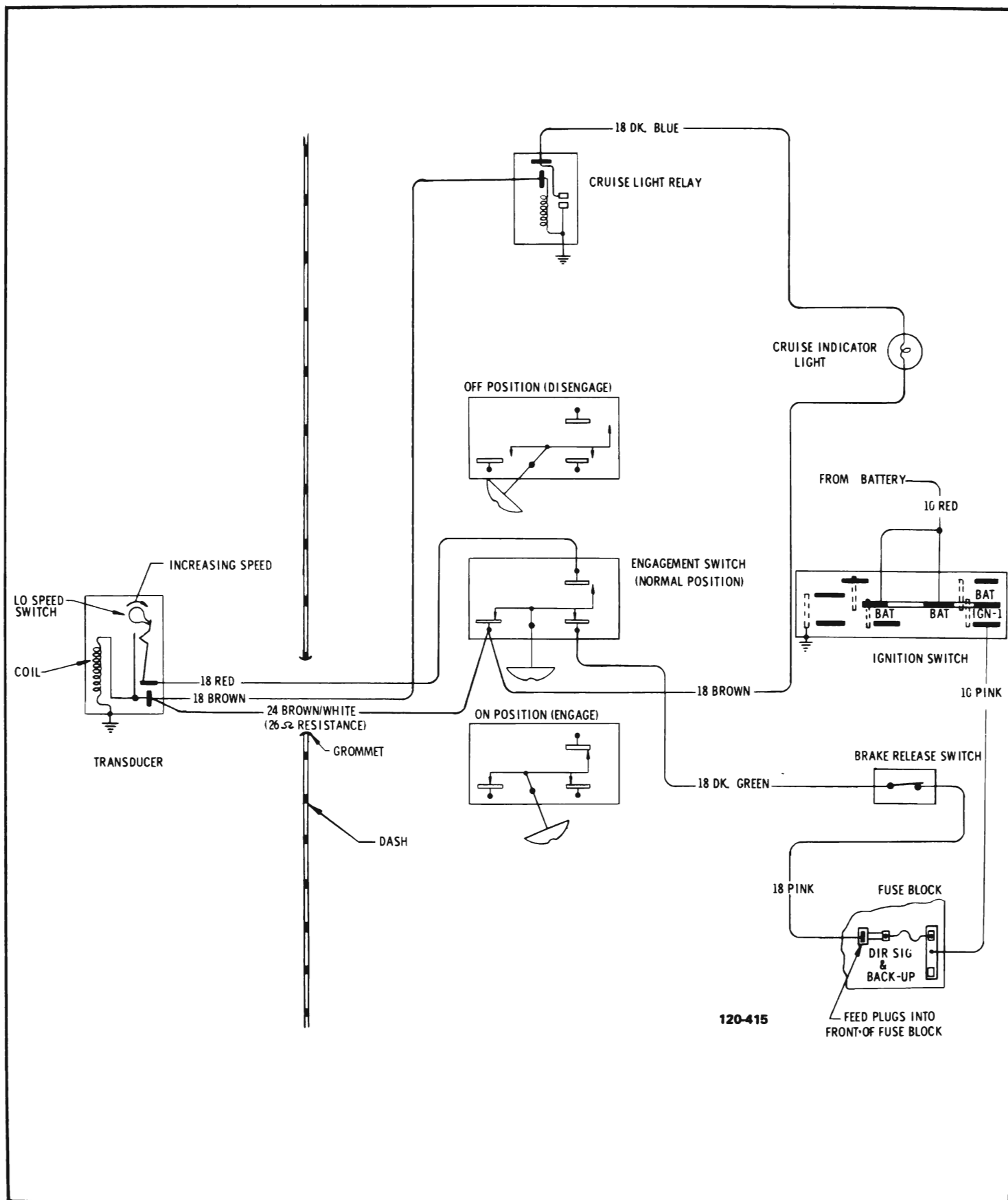

Figure 120-120 Cruise Master
Wiring Diagram - 43-44000

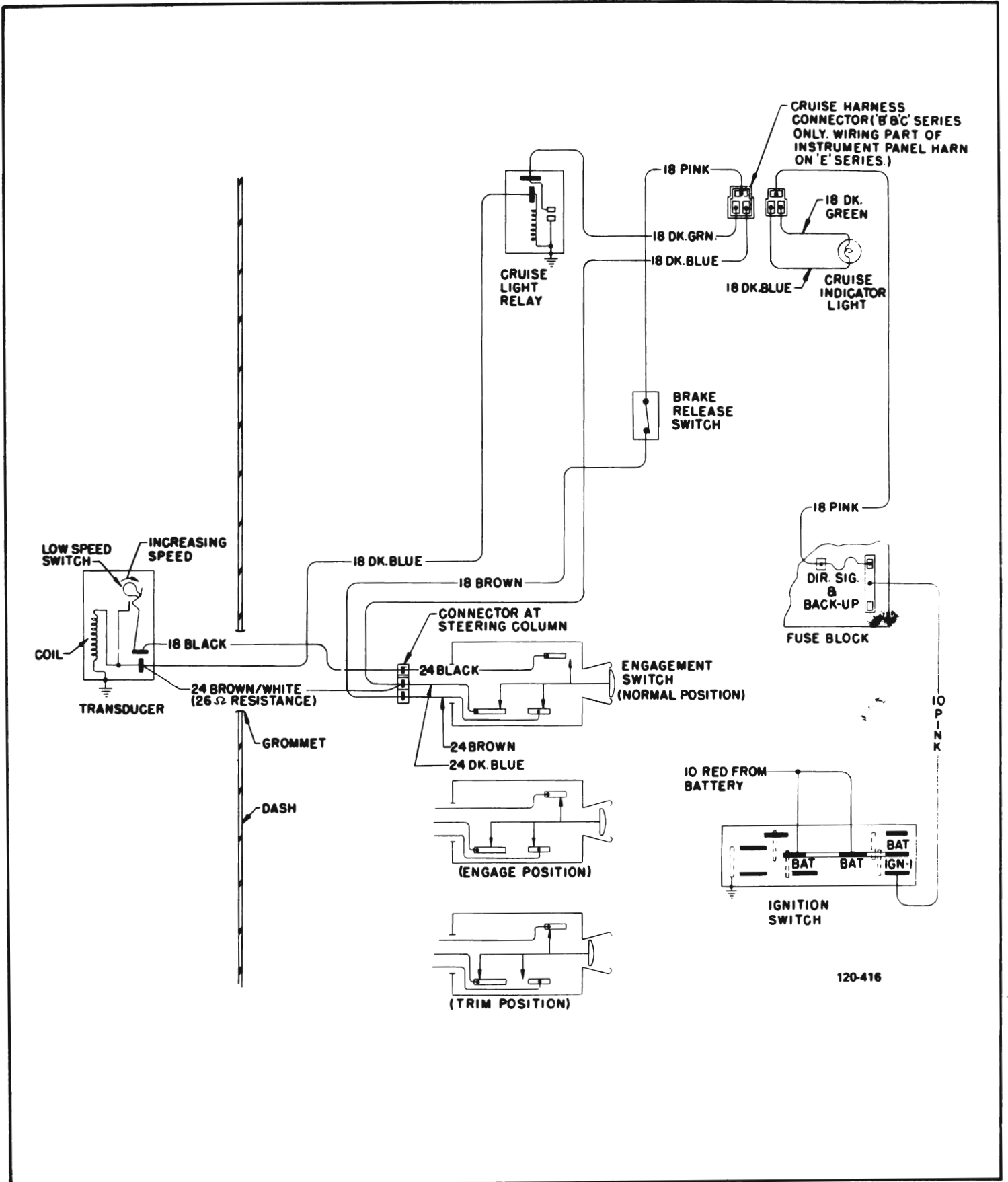

Figure 120-121 Cruise Master Wiring Diagram - 45-46-48-49000