

SECTION B

MAINTENANCE AND LUBRICATION

ALL SERIES

CONTENTS

Division	Subject	Paragraph
I	SPECIFICATIONS AND ADJUSTMENTS: Lubrication and Capacity	00-7
II	DESCRIPTION AND OPERATION: Not Applicable	
III	SERVICE PROCEDURES: Engine Oil Recommendations Periodically While Vehicle is Being Refueled Maintenance Recommendations — Every 4 Months Maintenance Recommendations — Every 8 Months or 6,000 Miles Maintenance Recommendations — Every 12 Months or 12,000 Miles Maintenance Recommendations — Every 18,000 Miles Maintenance Recommendations — Every 24,000 Miles Maintenance Recommendations — Seasonal (Cooling System) Vehicle Operation Under Dusty Conditions	00-8 00-9 00-10 00-11 00-12 00-13 00-14 00-15 00-16
IV	TROUBLE DIAGNOSIS: Not Applicable	

DIVISION I

SPECIFICATIONS AND ADJUSTMENTS

00-7 LUBRICATION AND CAPACITY CHARTS

a. Refer to Lubrication Charts

b. Refer to U.S., Imperial and Metric
Measure Chart.

1969 LUBRICATION CHART ALL MODELS EXCEPT RIVIERA

STEERING LINKAGE -Lube (7)
-CL- 6,000 Mi. or 8 Mos. .
Whichever Occurs First

DISTRIBUTOR CAM LUBRICATOR
Replace 12,000

ENGINE BELTS - Check Condition and Proper Tension 12,000

FUEL FILTER - Replace With Recommended Element 12,000 or 12 Mos.
Whichever Occurs First

WINDSHIELD WASHER FLUID
Check Level Periodically

LOWER BALL JOINTS (2) -CL- 6,000 Mi. or 8 Mo.
Whichever Occurs First

ENGINE OIL - Drain and Re-fill -EO-4 Mos.
Never exceed 6,000 miles between changes.

STD. STEERING GEAR - Lubed for Life
-CL- 24,000

CHECK HEAT CONTROL VALVE-HTL--6,000

POWER STEERING RESERVOIR - Check Fluid Level -PSF- 6,000

BRAKE MASTER CYLINDER - Maintain Lever 1/8" Below Top of Each Reservoir -HBF- 6,000

CHECK CLUTCH LASH - 6,000
Adjust if necessary

TIRES - Rotate 6,000
Maintain Pressure Periodically
Refer to Paragraph 100-3 For Correct Pressure

BRAKE MECHANISM - Apply at Starwheel Point of Contact and Lightly to 6 Surfaces on Which Shoe Rim Rest -BL- 18,000

AIR CONDITIONER - Functional Check Once A Year

RADIATOR - Maintain at "Fill-Cold" Arrow 6000
Replace Coolant - Every 2 Years

ENERGIZER (Battery) - Check Level PERIODICALLY

CRANKCASE VENTILATION ELEMENT AND AIR CLEANER ELEMENT
Inspect at each oil change - replace if necessary.
Replace at least every 24,000 miles - more often under dusty conditions

FRONT WHEEL BEARINGS - Repack When Brakes are Inspected or Serviced.

OIL FILTER ELEMENT - Replace With First Oil Change and Then at Alternate Oil Changes

UPPER BALL JOINTS (2) -CL- 6,000 Mi. or 8 Mos.
Whichever Occurs First

PCV VALVE - Replace 12,000

MANUAL TRANSMISSION - Maintain at Filler Opening - Flushing & Seasonal Changes NOT Recommended
M.P.G. - SAE - 80 or 90 6,000

AUTOMATIC TRANSMISSIONS
SUPER TURBINE 300
Clean Strainer - AT
Low Band - Adjust 24,000 Normal
12,000 Heavy Duty

TURBO HYDRAMATIC 350
Clean Strainer - AT 24,000 Normal
Low Band - Adjust 12,000 Heavy Duty

TURBO HYDRAMATIC 400
Replace Filter - AT 24,000 Normal
12,000 Heavy Duty

STANDARD DIFFERENTIAL
REAR AXLE - Maintain at Filler Opening to 1-4" Below - Flushing & Seasonal Changes NOT Recommended -MPG-SAE-80 or 90

For Complete Re-Fill Use Only Factory Hypoid Gear Lubricant - Unless Axle in Service 1,000 Mi. or more. Then Use -MPG-SAE- 80 or 90

POSITIVE TRACTION DIFFERENTIAL - Maintain at Filler Opening to 1-4" Below Flushing or Seasonal Change is NOT Recommended. Use TL-SAE 90 6,000

CAPACITIES (U.S. MEASURE)					
	L-6	350 (Except LeSabre)	350 (LeSabre)	400	430
COOLING SYSTEM					
With Heater	11.3	13.5	13.2	16.2	16.7
Without Heater	10.0	12.2	12.4	15.4	15.8
With Air Conditioner	13.0	13.5	13.6	16.7	17.0
CRANKCASE (All Series)					
Refill - Qts.	4				
With Oil Filter Change	5				
GAS TANK (Gals.)		<u>43-44000 Series</u>	<u>45-46-48000 Series</u>		
Approx.		20	25		
REAR AXLE (Pts.)		<u>43-44000 Series</u>	<u>45000 Series</u>	<u>46-48000 Series</u>	
		U.S. Built	Canada Built		
		3	3	4 1/4	
TRANSMISSION					
Super Turbine 300					
Turbo Hydra-matic 350					
Turbo Hydra-matic 400					
3-Speed Manual 3 1/2 Pts.					
4-Speed Manual 3 Pts.					
MANUAL STEERING GEAR (All Series) 11oz.					
POWER STEERING RESVOIR (All Series) 1 1/4 Qts.					

NOTE: See Page 00-
For Imperial and
Metric Measures

LUBRICANTS

CL Chassis Lubricant - Water Resistant Extreme Pressure EP No. 2 Multi-purpose Grease Which Meets G.M. Spec. 6031 M

AT DEXRON[®] Automatic Transmission Fluid G.M. Part No. 1050568-69-70 or Equivalent

EO Engine Oil (Current Viscosity) G.M. 6041-M*

HTL Buick CRC 5-56*

HBF Hydraulic Brake Fluid - Delco Super No. 11*

BL Brake Lub. Self-adjusting Per Spec. MP. 6805

MPG Multi-Purpose Gear Lubricant (MIL-L-2805-B)

TL Lub. Conforming to G.M. Specification 9985035

EP Multi-Purpose Grease EP No. 1 Grade Meeting G.M. Spec. 6040-M

PSF Buick Power Steering Gear Fluid or Equivalent Meeting G.M. Spec. 9986010

* Equivalent Acceptable if it Meets Specifications

Figure 00-13 - Lubrication Chart -
All Models Except Riviera

1969 RIVIERA LUBRICATION CHART

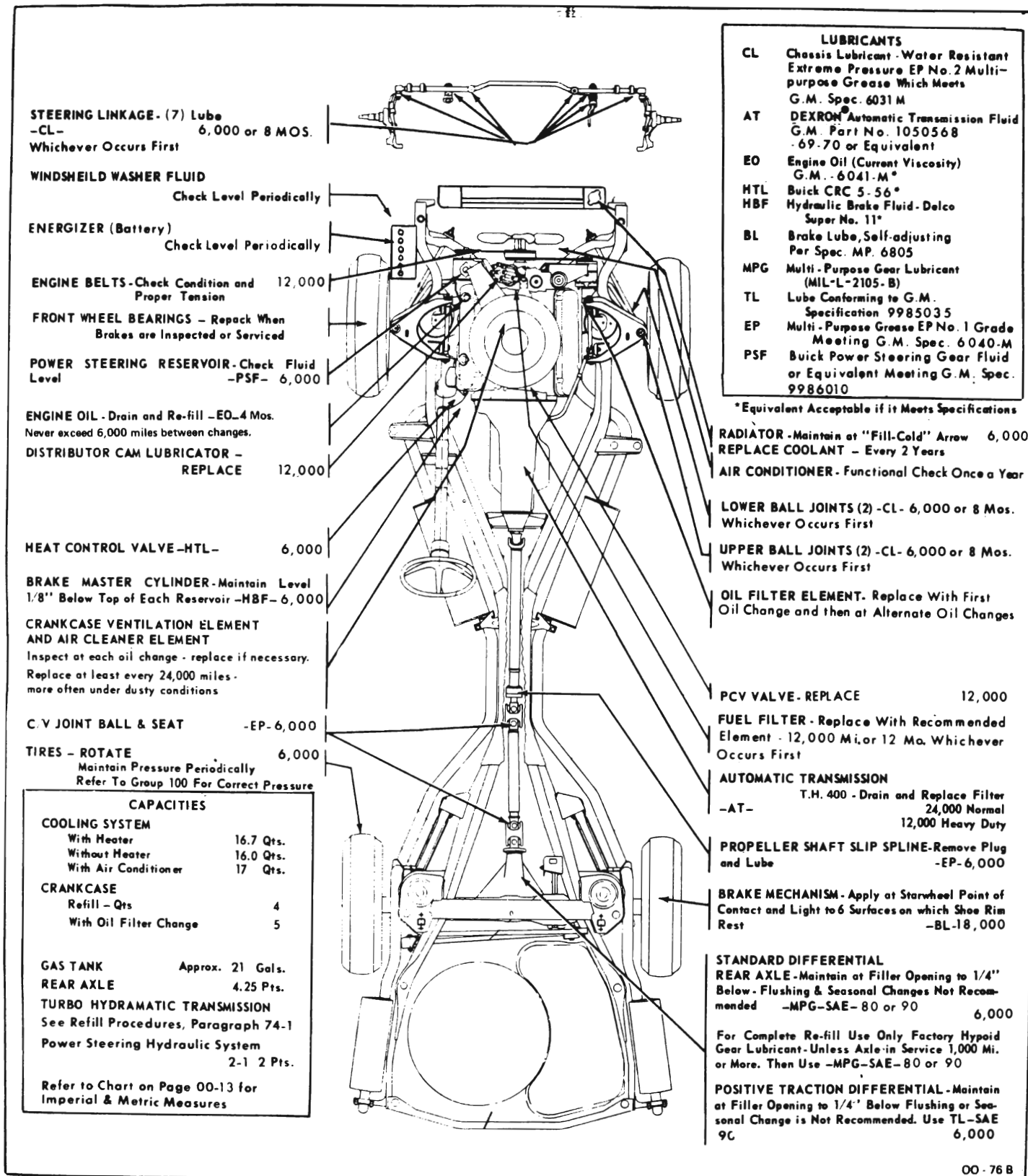

Figure 00-14 - Lubrication Chart - Riviera

U.S., IMPERIAL AND METRIC MEASURE CHART

	U.S. Measure	Imperial Measure	Metric Measure
Cooling System (L-6) 250 Cu. In. w/ Heater w/o Heater w/ Air Conditioner 350 Cu. In. (All Except LeSabre) w/ Heater w/o Heater w/ Air Conditioner 350 Cu. In. (LeSabre) w/ Heater w/o Heater w/ Air Conditioner 400 Cu. In. w/ Heater w/o Heater w/ Air Conditioner 430 Cu. In. w/ Heater w/o Heater w/ Air Conditioner	11.3 Qts. 10.0 Qts. 13.0 Qts. 13.5 Qts. 12.6 Qts. 13.5 Qts. 13.2 Qts. 12.4 Qts. 13.6 Qts. 16.2 Qts. 15.4 Qts. 16.7 Qts. 16.7 Qts. 15.8 Qts. 17.0 Qts.	9.42 Qts. 8.33 Qts. 10.83 Qts. 11.25 Qts. 10.40 Qts. 11.25 Qts. 11.00 Qts. 10.33 Qts. 11.33 Qts. 13.5 Qts. 12.8 Qts. 13.9 Qts. 13.9 Qts. 13.2 Qts. 14.2 Qts.	10.70 Liters 9.46 Liters 12.30 Liters 12.70 Liters 11.9 Liters 12.7 Liters 12.4 Liters 11.7 Liters 12.8 Liters 15.3 Liters 14.7 Liters 15.7 Liters 15.0 Liters 15.14 Liters 16.1 Liters
Crankcase (All Series) Refill With Oil Filter Change	4 Qts 5 Qts.	3.3 Qts. 4.20 Qts.	3.78 Liters 4.73 Liters
Gasoline Tank 43-44000 Series 45-46-48000 Series 49000 Series	Approx. 20 Gal. Approx. 25 Gal. Approx. 21 Gal.	16.67 Gal. 20.83 Gal. 17.50 Gal.	75.60 Liters 94.50 Liters 79.38 Liters
Rear Axle 43-44000 Series (U.S. Built) 43-44000 Series (Canada Built) 45000 Series 46-48-49000 Series	3 Pts. 3½ Pts. 3 Pts. 4¼ Pts.	2½ Pts. 3 Pts. 2½ Pts. 3½ Pts.	1.42 Liters 1.68 Liters 1.42 Liters 2.18 Liters
Transmission S.T. 300 T.H. 350 T.H. 400 3-Speed Manual 4-Speed Manual	See Paragraph 74-1 See Paragraph 75-1 See Paragraph 76-1 3½ Pts. 3 Pts.	3 Pts. 2½ Pts.	1.66 Liters 1.425 Liters
Manual Steering Gear (All Series)	11 Oz.	11 Oz.	311.85 Grams
Power Steering (All Series) Hydraulic System	2½ Pts.	2 Pts.	1.19 Liters

DIVISION III

SERVICE PROCEDURES

00-8 ENGINE OIL RECOMMENDATIONS

a. Engine Oil

Engine crankcase oils have a definite effect on ease of starting, oil economy, combustion chamber deposits and engine wear. It is recommended that an oil which, according to the label on the can, is: (1) intended for service MS and (2) passes car makers' tests or meets General Motors Standard GM 6041-M be used. Oils conforming to these types contain detergent additives.

b. Grade or Viscosity

The grade or viscosity (SAE number) of engine oil should be selected for the lowest anticipated temperature at which cold engine starting will be required as recommended in the temperature-viscosity chart in subparagraph d.

Oil level should be checked more frequently during the break-in period since somewhat higher oil consumption is normal until piston rings become seated.

The oil level should be maintained between the "operating range" marks on the gage rod; the space between marks represents one quart. Do not fill above the upper mark.

c. Oil Color

The color of "Service MS" type oil does not indicate its condition since it normally becomes dark (black or gray) after only a few hundred miles of driving. This is because the detergent content envelopes and holds in suspension extremely fine but harmless soot (soft carbon) and lead particles. The oil filter element does not remove this harmless material but it does remove harmful particles such as road dust, metal chips and hard carbon.

d. Engine Oil Change and Viscosity Recommendations

Anticipated Lowest Temperatures	Use SAE Viscosity Number	Change Your Oil at Least
Above Freezing (+32° F.)	SAE 10W-30 SAE 20W SAE 10W-40 SAE 20W-40	Every 4 Months*
Below Freezing (+32° F. to 0° F.)	SAE 10W SAE 10W-30 SAE 10W-40 SAE 5W-30	Every 4 Months*
Below 0° F.	SAE 5W-20 SAE 5W SAE 5W-30	Every 4 Months*

*Never exceed 6,000 miles between oil changes. During extreme driving conditions which produce oil contamination by dust, water, or other foreign material, the oil should be changed more frequently than every 4 months. Your authorized Buick dealer is well qualified to advise you.

NOTE: When changing the oil consider the lowest anticipated temperature for the next 4 months.

SAE 5W and 5W-20 oils are not recommended for sustained high speed driving.

SAE 30 oils may be used at temperatures above 60°F.

e. Crankcase Flushing

Flushing the crankcase with oils or solutions other than a good grade of 10-W engine oil is not recommended. When flushing to remove contamination appears advisable, use 3 quarts 10-W oil (4 quarts if filter is drained) and idle the engine at 1000 RPM (equivalent to 20 MPH) until the oil is hot, then drain crankcase and oil filter immediately after stopping engine. Fill crankcase with correct quantity and seasonal grade of oil. Install new oil filter element.

f. Engine Oil Supplement

Engine Oil Supplement or equivalent is a compound of the materials used by oil refiners to manufacture high detergent motor oils. It is intended for use in engines operating under aggravated conditions where engine deposits, rust and corrosion cannot be adequately retarded by motor oils readily available to the average

motorist. It is especially recommended for engines operated under restricted conditions such as frequent stops, short trips and slow speeds where such symptoms are sticking valves, valve lifters and rings are noticed.

Although Engine Oil Supplement may be used continually, it is normally unnecessary to use it with every crankcase refill. When used, the instructions on the container should be carefully observed.

00-9 PERIODICALLY WHILE VEHICLE IS BEING REFUELED

1. Battery - Check Level.

If necessary, add colorless, odorless drinking water to bring level to split ring at bottom of filler wells.

CAUTION: DO NOT OVERFILL.

2. Tires

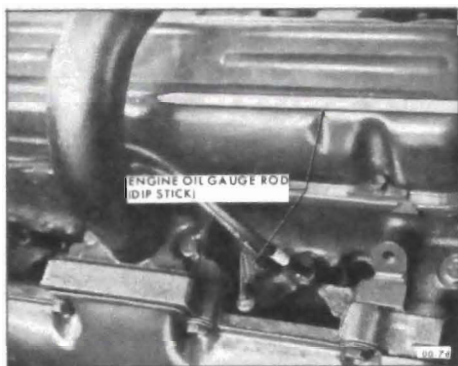

Figure 00-15 - Engine Oil Gauge Rod

For maximum tire life with corresponding good ride characteristics, maintain the tire pressure recommended in Group 100.

3. Engine Oil

This check should be performed last to allow the oil to drain back into the pan. Always add oil if the level is below the lower mark on the dip stick. See Figure 00-15.

4. Windshield Washer Solvent

If necessary, add solvent using GM Optikleen or equivalent. Follow instruction on label for correct concentration of solvent and water.

00-10 MAINTENANCE RECOMMENDATIONS EVERY 4 MONTHS

I. Engine Oil Change

Drain and refill engine crankcase every 4 months. If more than 6,000 miles are driven in a 4 month period, change oil every 6,000 miles. See subparagraph d. for oil recommendations.

Certain driving conditions including prolonged operation in sub-zero temperatures, trailer hauling and extensive idling necessitates more frequent oil changes. Under these conditions oil change intervals should not exceed 2 months or 3,000 miles, whichever occurs first.

2. Engine Oil Filter Change

Replace engine oil filter at the first

engine oil change and every second oil change thereafter.

To change, screw filter off the filter base and discard. Wipe the gasket area of the base clean and install a new gasket in the groove of a new AC type PF-24 filter (V-8), PF-25 (L-6) or equivalent. Lubricate the gasket and screw the filter on the nipple until the gasket just touches the base; tighten filter 2/3 of a turn more. Start engine. *Do not accelerate engine beyond the normal idle speed until oil pressure light goes out.*

Check the filter area for leaks after the engine has run for five (5) minutes.

3. Emission Control

Check engine idle speed, ignition timing, idle fuel mixture and Positive Crankcase Ventilation System at first oil change (4 months or 6,000 miles, whichever occurs first). Subsequent checks should be made every 12 months or 12,000 miles, whichever occurs first.

00-11 MAINTENANCE RECOMMENDATIONS - EVERY 8 MONTHS OR 6,000 MILES

I. Front Suspension and Steering Linkage

The front suspension and steering linkage should be lubricated with a water resistant extreme pressure EP #2 Multi-Purpose grease equivalent to GM Specification 9985038 every 8 months or 6,000 miles which occurs first.

NOTE: If lubricants not meeting GM Specification 9985038 are used, the lubrication interval should be shortened and should not exceed 2,000 miles.

Wipe dirt from the lubrication fittings and apply lubricant under pressure at the following points:

Upper Ball Joints (2 fittings)

Lower Ball Joints (2 fittings)

Steering Linkage (7 fittings)

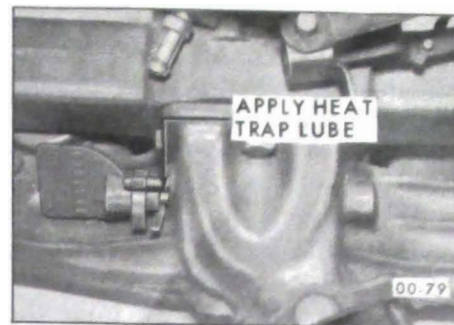

Figure 00-16 - Lubricating Points on Manifold Heat Control Valve - L-6 Engine

2. Manifold Heat Valve

Spray "Buick CRC 5-56" or equivalent on end of shaft, and free up if required. See Figure 00-16 or 00-17.

3. Clutch Lash

Should be adjusted every 6,000 miles. See Group 71 for procedures.

4. Constant Velocity Universal Joint Centering Ball 49000 Series

Rotate propeller shaft until fitting is visible through frame tunnel (49000) Series. Insert special grease gun adapter to bear solidly against fitting. One or two shots of grease is sufficient. See Figure 00-17. On the 49000 Series lubricate rear constant velocity Universal joint.

NOTE: Multi-Purpose Grease EP#1 grade is the only lubricant applicable at this point.

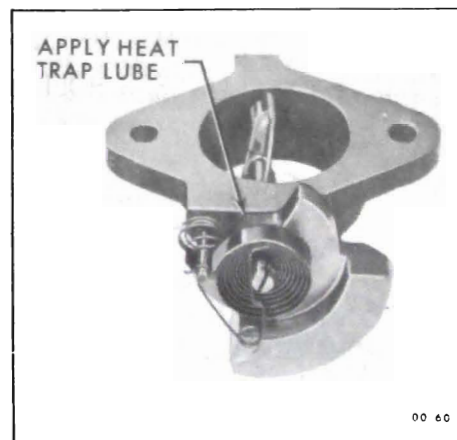

Figure 00-17 - Lubricating Points on Manifold Heat Control Valve - 350, 400 and 430 Cu. In. Engines

NOTE: DO NOT USE ORDINARY CHASSIS LUBE. An EP#1 lube is available through the Parts Department under Group 8.800.

On the 49000 series lubricating the constant velocity joint on certain hoists such as the frame contact type can be difficult as they allow the axle to drop and thus move the CV joint grease fitting away from the access hole. To correct, either the axle must be raised or the propeller shaft disconnected from the rear companion flange.

CAUTION: Reassembly of the propeller shaft should carefully be done as instructed in Group 40.

5. Propeller Shaft Slip Spline 49000 Series

Rotate propeller shaft so plug in propeller shaft is accessible through front hole in frame tunnel. See Figure 00-18. Remove plug and install adapter (Alemite #327045 or equivalent) in propeller shaft. One or two shots from a lever type grease gun are sufficient. Remove adapter and reinstall plug.

Again it is emphasized that a lubricants meeting the GM specification 6040-M for Multi-Purpose Grease EP number 1 grade is to be used in these areas. *Ordinary chassis lube must not be used.* An EP#1 lube is available through the Parts Department under Group 8.800.

6. Tires

For best tire mileage, rotate tires every 6,000 miles as shown in Figure 00-19. After tire rotation, adjust tire pressure to the recommended pressure listed in Group 100.

A decrease in traction and anti-skid properties, as well as road hazard resistance, occurs as tires become worn out. The original equipment tires incorporate built-in tread wear indicators to assist in judging when tires should be replaced. These indicators are molded into the bottom of the tread grooves and will appear as 1/2 inch wide bands when tire tread depth becomes a 1/16 of an inch. When the indicators appears in two

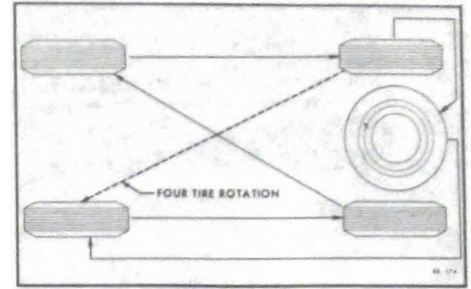

Figure 00-19 - Tire Rotation Method



Figure 00-20 Tread Wear Indicators

or more adjacent grooves, tire replacement is recommended. See Figure 00-20.

7. Check Fluid Level

Brake Master Cylinder All models are equipped with dual master cylinders. Maintain fluid level 1/8" below top of each filler opening. When adding brake fluid, use Delco Supreme #11 hydraulic brake fluid or equivalent. Never use reclaimed fluid, mineral oil, or fluid inferior to SAE Standard 70-R-3.

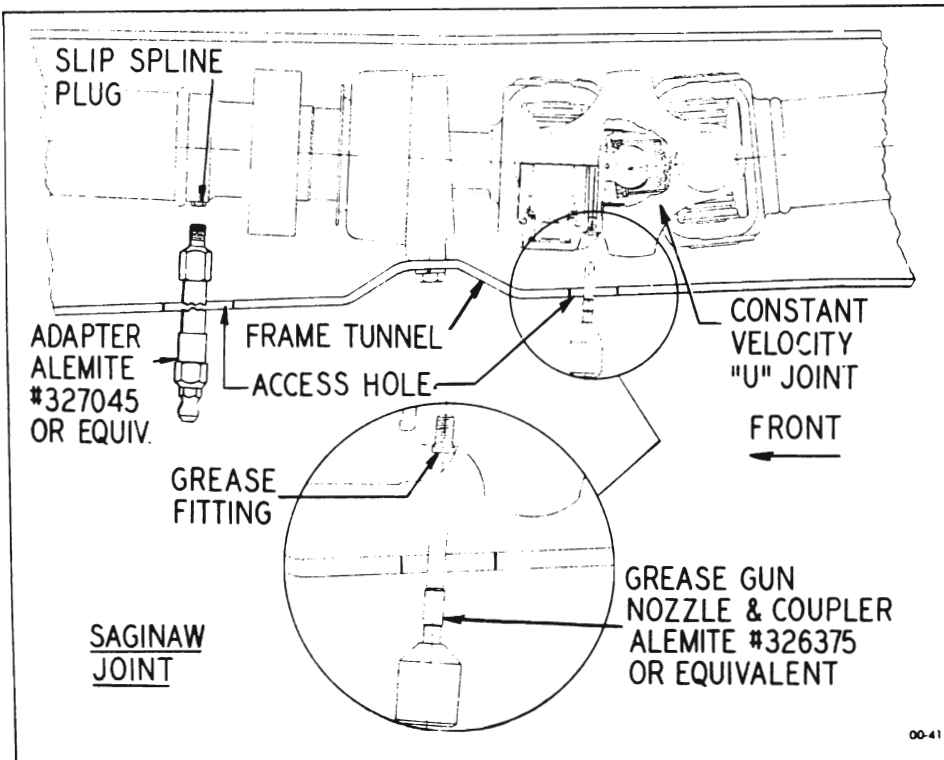

Figure 00-18 - Propeller Shaft Lubrication Points (49000 Series)

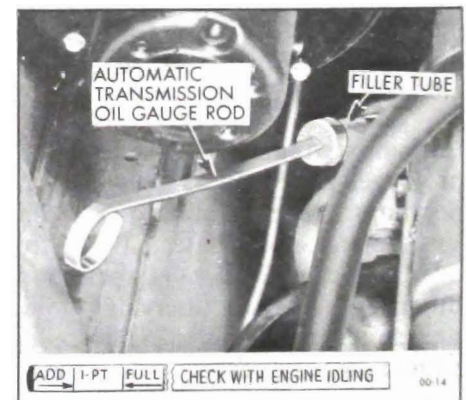

Figure 00-21 - Automatic Transmission Oil Gauge Rod

Manual Transmission Check oil level, after allowing time for oil to settle. Clean the surrounding area before removing filler plug. Level should be maintained at filler plug opening by adding SAE/80 or 90 multi-purpose gear lubricant.

NOTE: Draining and flushing transmission is not required.

Automatic Transmission IMPORTANT: Refer to Paragraph 74-1, subparagraph c for correct refill procedures.

Power Steering Reservoir Thoroughly clean any excessive amounts of dirt from reservoir cap before removing. Maintain level in accordance with fill marking on cap dip stick. Use *only* Power Steering Fluid meeting GM Specification 9985010.

Standard Differential Rear Axle Check lubricant level after allowing time for lube to settle. Clean surrounding area before removing filler plug. Level should be maintained not lower than 1/4" below filler plug opening by adding SAE 80 or 80-90 Multi-Purpose Gear Lubricant meeting MIL-L-2105B specification.

NOTE: Draining and flushing are not recommended. When complete refilling is necessary, SAE 80 or 80-90 Multi-Purpose Gear Lubricant may be used, provided the axle has been in service for 1,000 miles or more. Axles with less than 1,000 miles must not be completely refilled with any lubricant other than Factory Hypoid Lubricant or equivalent.

Positive Traction Differential Rear Axle U.S. Built Axles Identified by a stainless steel plate

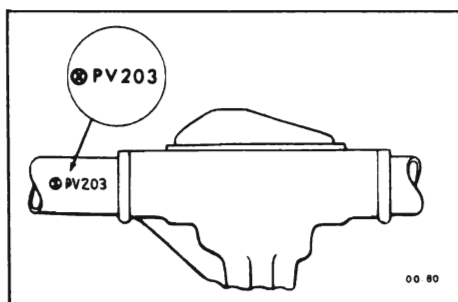

Figure 00-22 - Positive Traction Identification - U.S. Built Axles

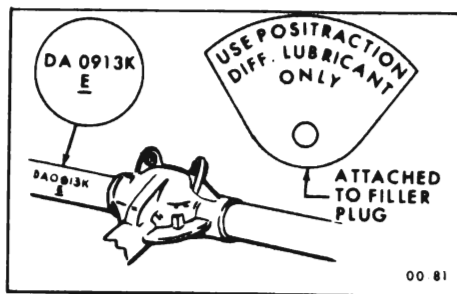

Figure 00-23 - Positive Traction Identification - Canadian Built Axles

attached by a rear cover bolt starting "Use limited slip differential lube only" and by an X enclosed in a circle stamped on the bottom of the left axle tube. See Figure 00-22.

Canadian Built Axles

Identified by a red plastic tag attached to the filler plug stating "USE POSITRACTION DIFF. LUBRICANT ONLY" and by an E stamped below the production month and date on the front face of right axle tube. See Figure 00-23.

Check lubricant level after allowing time for lubricant to settle.

Level should be maintained not lower than 1/4" below filler plug opening by adding SAE 90 gear lube meeting GM Specification 9985035.

NOTE: If Positive Traction Differential lube becomes contaminated, the axle assembly may be flushed with engine oil. Refer to Group 40 for complete flushing and refill procedures.

8. Minor Lubrication

Occasionally lubricate the pivot points at the following locations with the recommended material.

Hood Hinge - Lubriplate or equivalent.

Door Hinges - Lubriplate or equivalent.

Door Lock Cylinders - Powered graphite. DO NOT USE OIL.

Gas Tank Door Hinge - Engine Oil.

Door Lock Fork Bolt - Stick type lubricant.

Rear Compartment lid lock - Lubriplate or equivalent.

Door Jam Switch - Lubriplate or equivalent.

Front Seat Adjuster Tracks - Lubriplate or equivalent.

Convertible Top Mechanism - Lubriplate or equivalent.

Station Wagon Folding Seat Linkage - Dripless Oil.

Tail Gate Lock Strider - Stick type lubricant.

Tail Gate Hinges - Dripless Oil.

Folding Top Lift Cylinder Piston - With folding top in raised position, wipe exposed portion of each top lift cylinder piston rod with a cloth dampened with brake fluid to remove any oxidation or accumulated grime. With another clean cloth apply a light film of brake fluid to act as a lubricant.

NOTE: Do not allow brake fluid to come in contact with any painted or trimmed parts of the body.

NOTE: Do not lubricate carburetor or throttle linkage.

9. Body Rubber Parts

Door, hood, and rear compartment rubber weatherstrips may be kept pliable and quiet by the application of a light coat of GM Part No. 1050110 Lubricant or suitable silicone lubricant equivalent.

00-12 MAINTENANCE RECOMMENDATIONS EVERY 12,000 MILES

I. Ignition Points, Timing, Spark Plugs, Point Dwell and Idle Speed Mixture

It is recommended that the spark plugs be cleaned and gapped or, if necessary replaced at 12,000 miles.

Also the ignition points should be replaced and the engine timing, point dwell and idle speed mixture should be set to specifications as stated in Group 69.

NOTE: More frequent service may be required depending on driving conditions.

2. Fuel Filters

Replacement of fuel filter is recommended at 12,000 miles or 12 months whichever occurs first. Remove from carburetor inlet and replace with filter type GF-427 or equivalent for L-6 and 350 2 bbl. or GF-441 or equivalent for all V-8's with 4 bbls. More frequent servicing may be necessary if contaminants have entered the fuel system.

3. Distributor Cam Lubricator

It is recommended that the distributor cam lubricator be replaced every 12,000 miles. Remove from post on distributor plate and replace with a new wick. See Figure 00-24.

4. Positive Crankcase Ventilator Valve

Replace PCV valve at 12,000 miles or

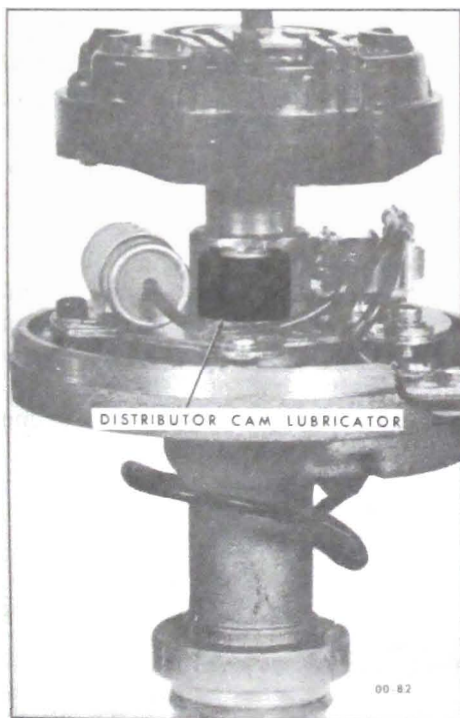

Figure 00-24 - Distributor Cam Lubricator

12 months whichever occurs first. Remove positive crankcase ventilation valve and replace with a new AC-type CV-679C or equivalent for V-8 engines, or AC-type CV-723C or equivalent for L-6 engines.

Inspect PCV system hoses and fittings, clean and replace as necessary. Make certain all connections are tight.

5. Belts

Inspect engine driven belts for condition and proper tension.

6. WHEEL Alignment and Balance

Refer to Group 30.

7. Super Turbine 300, Turbo Hydra-matic 350 and 400

If transmission is subjected to heavy duty usage, such as heavy city traffic during hot weather, or in commercial use, when engine is regularly idled for prolonged periods, the transmission recommendations listed under "24,000 Mile" should be performed at 12,000 miles.

8. Air Conditioner-Equipped Model

It is recommended that the system should be functionally checked by the dealer each spring.

Keep insects and dirt from accumulating on the air conditioner condenser.

00-13 MAINTENANCE RECOMMENDATIONS EVERY 18,000 MILES

1. Brakes

Examine brake linings for wear and the self-adjusting mechanism for proper functioning. Although linings may not be excessively worn, this check will indicate when another inspection should be made.

If equipped with Disc brakes observe friction pad thickness through the inspection opening in the caliper.

Refer to Group 50 for service procedure and specifications.

If required use Buick approved replacement linings and friction pads or equivalent. Lubricate self-adjusting mechanism adjusting screw with Delco Moraine Special Brake Lubricant or equivalent.

2. Front Wheel Bearings

There is no periodic lubrication schedule for front wheel bearings. They may be re-lubricated whenever brakes are serviced. Always follow with correct bearing adjustment as outlined in Group 100.

00-14 MAINTENANCE RECOMMENDATIONS EVERY 24,000 MILES

1. Automatic Transmission - Super Turbine 300, Turbo Hydra-matic 350 and 400

At this interval the automatic transmission should be drained, the oil pan and oil strainer cleaned (S.T. 300 and Turbo Hydra-matic 350), and oil filter replaced (Turbo Hydra-matic 400) and new oil added as stated in paragraph 74-1, 75-1 or 76-1.

When adding transmission fluid use only DEXRON Automatic Transmission Fluid or Automatic Transmission Fluid identified with the mark DEXRON on the container.

LOW BAND ADJUSTMENT - Super Turbine "300" Only

Low band adjustment is required at this interval. Refer to paragraph 74-25 for correct adjustment procedure.

2. Manual Steering Gear

At this interval, the manual steering gear lubricant level should be checked. Remove the bolt on gear cover marked "Lube". Add chassis lubricant conforming to GM Specification 9985038 as necessary.

3. Engine Air Cleaner Element

Replacement of element is required

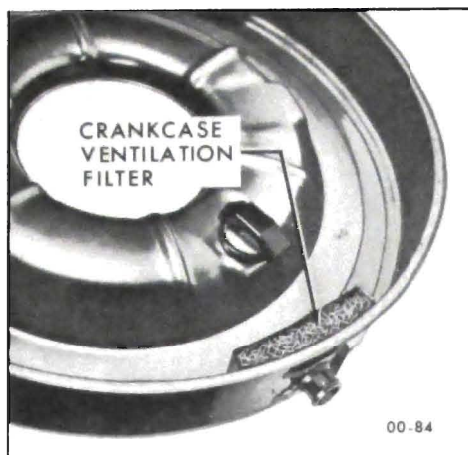

Figure 00-25 - Crankcase Ventilation Filter Location

every 24,000 miles. If car is operated in dusty territory, check condition of air cleaner element more frequently and replace if necessary. Service with the following AC type air cleaner element or equivalent for maximum engine protection.

ELEMENT		
Usage	Regular	Heavy Duty
L-6	A169CW	A227C
350-2	A329C	A368C
350-4	A329C	A368C
400-4	A212CW	A279C
430-4	A329C	A368C

00-86A

4. Crankcase Ventilation Filter

Inspect at every oil change - replace if necessary with part number

6484966 group 3.417. Replace at least every 24,000 miles - more often under dusty conditions. See Figure 00-25.

5. Cooling System Inhibitor

It is required that GM cooling system inhibitor and sealer or equivalent be added every 24,000 miles.

00-15 MAINTENANCE RECOMMENDATIONS SEASONAL (COOLING SYSTEM)

I. Anti-Freeze

An ethylene glycol type anti-corrosive and anti-freeze cooling system protection solution developed for year around use (General Motors Specifications, GM 1899-M) has been installed in the cooling system of the vehicle at the factory for protection to -20°F. (-32°F. in Canada).

Although this type coolant should be maintained to at least 0°F throughout the year, once every two years the cooling system should be drained, flushed and ethylene glycol type anti-freeze also conforming to General Motors Specification GM 1899-M installed. At this time, also add GM cooling system inhibitor and sealer or equivalent. *Water alone, Methanol, or alcohol type anti-freeze is definitely not recommended.* If water alone must be

used as coolant in an emergency, it is extremely important that Buick Heavy Duty Cooling System Protector and Water Pump Lubricant or equivalent be added to the cooling system as soon as possible. If any other cooling system protector is used, be sure it is labeled to indicate that it meets General Motors Specification GM 1894-M.

00-16 VEHICLE OPERATION UNDER DUSTY CONDITIONS

When cars are operated in adverse dusty climates or conditions, the following precautions should be taken to prevent dirt and other foreign materials from entering the engine.

1. Change Engine Oil

Change more often than is recommended in subparagraph C. The severity of the conditions should determine the frequency of oil changes.

2. Oil Filter

Change each time that the oil is changed under these conditions.

3. Air Cleaner Element

Inspect element. If dirty, replace as recommended under subparagraph K.