

SECTION A

SUPER TURBINE "300"

AUTOMATIC TRANSMISSION

CONTENTS

Division	Paragraph	Subject	Page
I		SPECIFICATIONS AND ADJUSTMENTS:	
	74-1	General Specifications	74-3
	74-2	Bolt Torque Specifications	74-5
	74-3	Detent Switch.	74-5
II		DESCRIPTION AND OPERATION:	
	74-4	Description of the Super Turbine 300 Automatic Transmission. . .	74-6
	74-5	Mechanical Operation of the Super Turbine 300 Automatic Transmission	74-8
	74-6	Functions of Valves and Hydraulic Control Units	74-13
	74-7	Hydraulic Operation	74-16
III		SERVICE PROCEDURES:	
	74-8	Transmission Assembly-Removal and Installation	74-28
	74-9	Preliminary Instructions	74-28
	74-10	Removal of Oil Pan, Oil Strainer, Valve Body, Low Servo Cover and Piston Assembly	74-28
	74-11	Removal of Oil Pump, Forward Clutch, and Low Band	74-32
	74-12	Removal of Speedometer Driven Gear, Rear Bearing Retainer, Retainer Oil Seal, Bushing and Governor	74-33
	74-13	Removal of Speedometer Drive Gear and Vacuum Modulator	74-34
	74-14	Removal of Planetary Gear Set, Reverse Clutch and Parking Lock Mechanism	74-35
	74-15	Valve Body Disassembly, Inspection and Reassembly	74-37
	74-16	Low Servo Disassembly and Reassembly	74-39
	74-17	Disassembly Inspection and Reassembly of the Oil Pump	74-40
	74-18	Disassembly Inspection and Reassembly of Forward Clutch	74-43
	74-19	Disassembly and Reassembly of Speedometer Driven Gear	74-46
	74-20	Removal and Installation of Governor Driven Gear	74-46
	74-21	Planet Carrier Disassembly Inspection and Reassembly	74-47
	74-22	Assembly of Transmission from Major Parts	74-51
	74-23	Installation of Low Servo Assembly, Low Band, and Forward Clutch	74-54
	74-24	Installation of Oil Pump Guide Pin, Gasket and Oil Pump Assembly	74-55
	74-25	Low Band Adjustment.	74-56
	74-26	Installation of Speedometer Driving Gear	74-56
	74-27	Installation of Valve Body Assembly	74-57
	74-28	Installation of Governor and Vacuum Modulator	74-59
	74-29	Converter Checking Procedure.	74-59
IV		TROUBLE DIAGNOSIS:	
	74-30	Sequence for Super Turbine 300 Transmission Diagnosis	74-60
	74-31	Super Turbine 300 Transmission Checking Procedures	74-60
	74-32	External Oil Leaks	74-61
	74-33	Super Turbine 300 Trouble Diagnosis Chart.	74-62
	74-34	Super Turbine 300 Vacuum Modulator Diagnosis	74-66
	74-35	Super Turbine 300 Oil Pressure Checks	74-68

DIVISION I—SPECIFICATIONS AND ADJUSTMENTS

74-1 GENERAL SPECIFICATIONS

a. Model Designations

Trans. Model	Converter Assembly Information	Valve Body Plate Ident. See Figure 74-335	Reverse Clutch Piston	Reverse Clutch		Forward Clutch		Forward Clutch Piston	Modulator Assembly Note: Refer to Par. 74-34 for diagnosis procedure.	Model Usage
				Driven Plate Req'd.	Drive Plate Req'd.	Driven Plate Req'd.	Drive Plate Req'd.			
MH	Pink Dot of Paint	Six Notches	1371900	5	5	6	5	1378663	Prod. No. 8623365 Serv. No. 8623947	All Sportwagons
ME	Pink Dot of Paint	Six Notches	1371900	5	5	6	5	1378663	Prod. No. 8623365 Serv. No. 8623947	All 350 Cu. In. Engines except Sportwagons
LC	Green Dot of Paint	Six Notches	1371899	4	4	5	4	1378662	Prod. and Serv. No. 1367032	All 250 Cu. In. L-6 Model Cars

b. Transmission Identification Number and Car Serial Number

A production day and shift built number, transmission model and model year are stamped on the low servo cover located on the middle right side of the transmission case. See Figure 74-1. Since the production day built number and model number furnishes the key to construction and interchangeability of parts in each transmission, they should be used when selecting replacement parts as listed in the master parts list. The model number and day built number should always be furnished on product reports, AFA forms, and all correspondence with the factory concerning a particular transmission.

On all 1968 Super Turbine 300 transmissions the car serial number is stamped on the lower left side of the transmission case, next to the detent solenoid case connector See Figure 74-3.

c. Super Turbine 300 Fluid Recommendations

Use DEXRON Automatic Transmission Fluid only in all 1968 model Super Turbine 300 automatic transmissions (GM Part No. 1050568-69-70 or any other fluid having DEXRON identifications).

DEXRON is an especially formulated automatic transmission fluid designed to improve transmission operation.

NOTE: Use DEXRON or type "A" automatic transmission fluid identified by the mark "AQ-ATF" followed by a number and the suffix letter "A" (AQ-ATF-XXXX-A) in all automatic transmissions prior to the 1968 models.

The oil pan should be drained and the strainer cleaned every 24,000 miles and fresh fluid added to obtain the proper level on the dipstick. See sub-paragraph 2 for proper refill procedures. For

cars subjected to heavy city traffic during hot weather, or in commercial use, when the engine is regularly idled for prolonged periods, the oil pan should be drained and the strainer cleaned every 12,000 miles.

1. Checking and Adding Fluid

Fluid level should be checked at every engine oil change. The

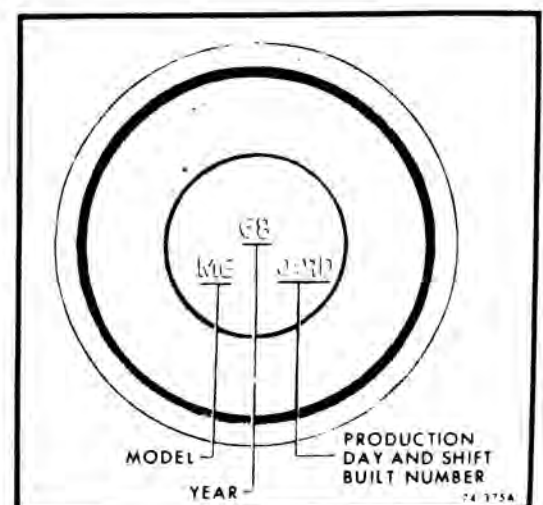

Figure 74-1—Model Identification

"FULL" and "ADD" marks on the transmission dipstick indicate one (1) pint difference. To determine proper fluid level, proceed as follows:

NOTE: The Super Turbine 300 transmission is designed to operate at the full mark on the dipstick at normal operating temperature (180°F) and should be checked under these conditions. The normal operating temperature is obtained only after at least 15 miles of highway type driving or the equivalent of city driving.

To determine proper level, proceed as follows:

1. With manual control lever in Park position start engine. DO NOT RACE ENGINE. Move manual control lever through each range.
2. Immediately check fluid level with selector lever in Park, engine running, and vehicle on LEVEL surface.

At this point, when a reading is made, fluid level on the dipstick should be at the "FULL" mark.

3. If additional fluid is required, add fluid to the "FULL" mark on the dipstick.

If the vehicle cannot be driven sufficiently to bring the transmission to operating temperature and it becomes necessary to check the fluid level, the transmission may be checked at room temperature (70°F) as follows:

1. With manual control lever in Park position start engine. DO NOT RACE ENGINE. Move manual control lever through each range.
2. Immediately check fluid level with selector lever in Park, engine running, and vehicle on LEVEL surface.

At this point, when a reading is made, fluid level on the dipstick should be 1/4" below the "ADD" mark.

3. If additional fluid is required add fluid to bring level to 1/4" below the "ADD" mark on the dipstick.

NOTE: If transmission fluid level is correctly established at 70°F it will appear at the "FULL" mark on the dipstick when the transmission reaches normal operating temperature (180°F). The fluid level is set 1/4" below the "ADD" mark on the dipstick to allow for expansion of the fluid which occurs as transmission temperatures rise to normal operating temperature of 180°F.

CAUTION: Do Not Overfill, as foaming and loss of fluid through the vent pipe might occur as fluid heats up. If fluid is too low especially when Cold, complete loss of drive may result which can cause transmission failure.

2. Draining oil pan and cleaning strainer assembly.

(a) Raise car on hoist or place on jack stands, and provide container to collect draining fluid.

(b) Remove oil pan and gasket. Discard gasket.

(c) Drain fluid from oil pan. Clean pan with solvent and dry thoroughly with clean compressed air.

(d) Remove strainer assembly. Remove and discard oil strainer to case "O" ring.

(e) Thoroughly clean strainer assembly in solvent and dry thoroughly with clean compressed air.

(f) Install new oil strainer to case "O" ring. Install strainer assembly.

(g) Install new gasket on oil pan and install pan. Tighten attaching bolts to 12 lb. ft.

(h) Lower car and add 3 pints of transmission fluid through filler tube.

(i) With manual control lever in Park position, start engine. DO

NOT RACE ENGINE. Move manual control lever through each range.

(j) Immediately check fluid level with selector lever in Park, engine running, and vehicle on LEVEL surface.

(k) Add additional fluid to bring level to 1/4" below the "ADD" mark on the dipstick.

CAUTION: Do not overfill.

3. Adding Fluid to Fill Dry Transmission and Converter Assembly

The fluid capacity of the Super Turbine 300 transmission and converter assembly is approximately 19 pints, but correct level is determined by the mark on the dipstick rather than by amount added. In cases of transmission overhaul, when a complete fill is required, including a new converter proceed as follows:

(a) Add 8 pints of transmission fluid through filler tube.

The converter should be replaced on any major failure, such as a clutch or gearset, and an excessive amount of foreign material is indicated in the pan.

NOTE: If installation of a new converter is not required add only 5 pints of transmission fluid.

(b) With manual control lever in Park position start engine and place on cold idle cam. DO NOT RACE ENGINE. Move manual control lever through each range.

(c) Immediately check fluid level with selector lever in Park, engine running, and vehicle on LEVEL surface.

(d) Add additional fluid to bring level to 1/4" below the "ADD" mark on the dipstick.

CAUTION: Do not overfill.

d. Low Band Adjustment

The low band should be adjusted

every 24,000 miles. See Paragraph 74-25, for low band adjustment instructions. Under heavy duty operation the low band should be adjusted every 12,000 miles.

e. Super Turbine 300 Towing Instructions

If a Buick equipped with Super Turbine 300 transmission must be towed, the following precautions must be observed:

The car may be towed safely on its rear wheels with the shift

lever in neutral position at speeds of 35 miles per hour or less under most conditions.

However, the drive shaft must be disconnected or the car towed on its front wheels if

- Tow speeds in excess of 35 mph are necessary,
- Car must be towed for extended distances (over 50 miles) or,
- Transmission is not operating properly.

If car is towed on its front

wheels, the steering wheel should be secured to keep the front wheels in a straight-ahead position.

f. Rocking Car

If it becomes necessary to rock the car to free it from sand, mud or snow, move the selector lever from "D" to "R" in a repeat pattern while simultaneously applying moderate pressure to the accelerator. Do not race engine. Avoid spinning wheels when trying to free the car.

74-2 BOLT TORQUE SPECIFICATIONS

Part	Location	Thread Size	Torque Lb. Ft.
Bolt	Case to Cylinder Block	3/8 -16	35-35
Screw-Tapping	Converter Cover Pan to Transmission Case	1/4 -20	8-12
Pipe Fitting	Water Cooler Pipes to Transmission Case	1/4 -18	25-35
Nut	Nut for Low Band Adjusting Screw	7/16-20	20-30
Bolt	Pump Body to Pump Cover	5/16-18	16-24
Bolt	Transmission Case	5/16-18	8-12
Bolt	Valve Body Assembly to Transmission Case	5/16-18	8-12
Bolt	Solenoid Valve to Valve Body	1/4 -20	8-12
Bolt	Vacuum Modulator to Transmission Case	5/16-18	8-12
Bolt	Pump Assembly to Transmission Case	5/16-18	16-24
Bolt	Rear Bearing Retainer to Transmission Case	3/8 -16	25-35
Bolt-Special	Oil Pan to Transmission Case	5/16-18	10-16
Bolt	Speedometer Sleeve Retainer to Bearing Retainer	5/16-18	5-10
Bolt	Governor Cover to Transmission Case	5/16-18	8-12

74-3 DETENT SWITCH (See Figure 74-2 for Installation and Adjustment of Detent Switch)

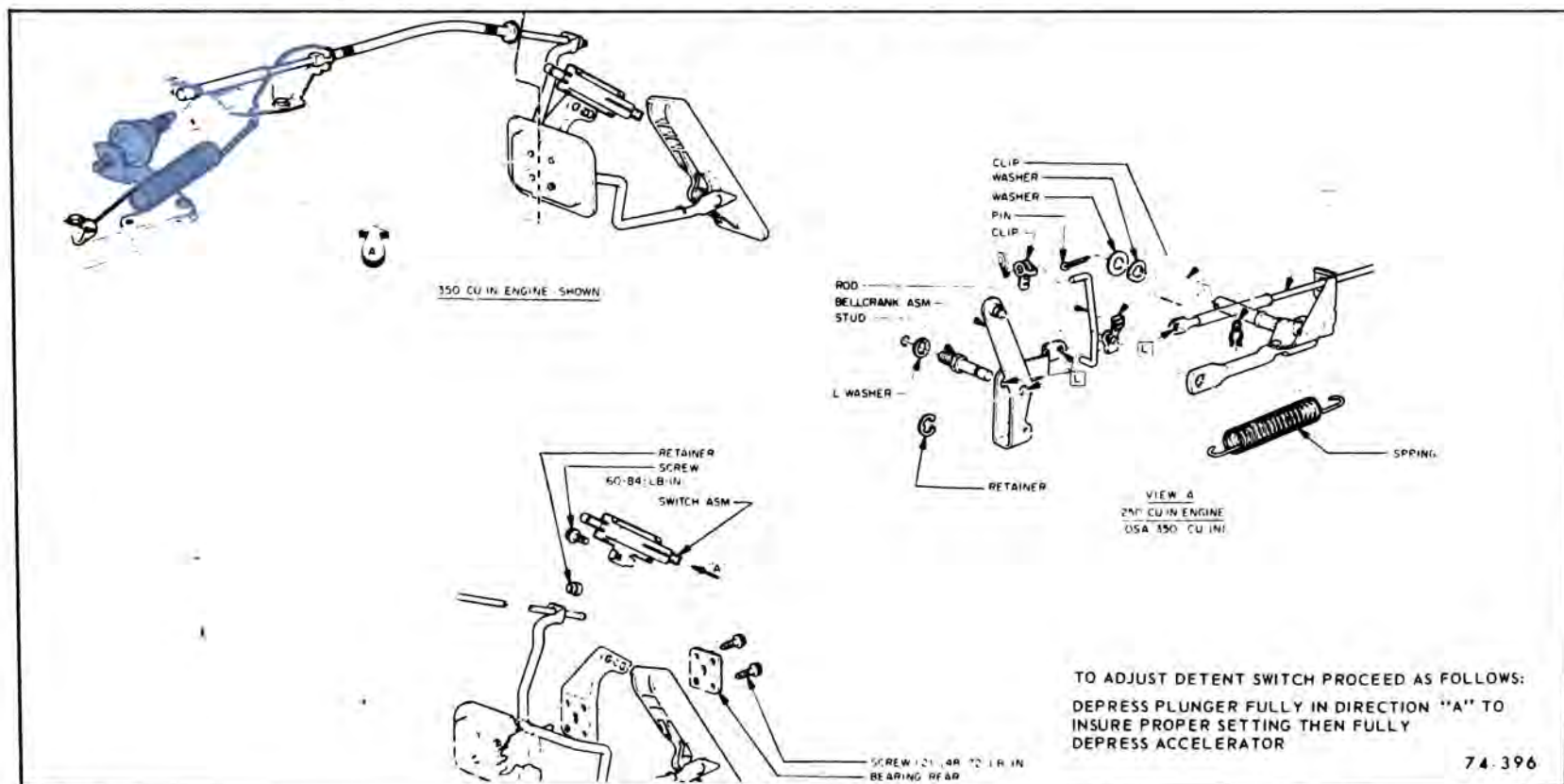

Figure 74-2—Transmission Detent Switch Adjustment

DIVISION II—DESCRIPTION AND OPERATION

74-4 DESCRIPTION OF THE SUPER TURBINE 300 TRANSMISSION

The Super Turbine 300 transmission, see figure 74-3, is a fully automatic unit consisting primarily of a 3-element hydraulic torque converter and a compound planetary gear set. Two multiple-disc clutches, and a band provide the friction elements required to obtain the desired function of the planetary gear set.

The 3-element torque converter consists of a pump, turbine and a stator assembly. The stator is mounted on a one way roller clutch which will allow the stator to turn clockwise, but not counterclockwise.

NOTE: References to clockwise and counterclockwise are determined by looking toward rear of car.

The torque converter is of welded construction and is serviced as a complete assembly. The unit is filled with oil and is attached to the engine crankshaft by a flywheel, thus always rotates at engine speed. The converter pump is an integral part of the converter housing, therefore the pump blades, rotating at engine speed,

set the oil within the converter into motion and direct it to the turbine, causing the turbine to rotate.

As the oil passes through the turbine it is traveling in such a direction that if it were not redirected by the stator it would hit the rear of the converter pump blades and impede its pumping action. So at low turbine speeds, oil is redirected by the stator to the converter pump in such a manner that it actually assists the converter pump to deliver power, or multiply engine torque.

As turbine speed increases, the direction of oil leaving the turbine changes and flows against the rear side of the stator vanes in a clockwise direction. Since the stator is now impeding the smooth flow of oil, its roller clutch releases and it revolves freely on its shaft. Once the stator becomes inactive, there is no further multiplication of engine torque within the converter. At this point, the converter is merely acting as a fluid coupling as both the converter pump and turbine are being driven at approximately the same speed.

A hydraulic system pressurized by a gear type pump provides the working pressure required to operate the friction elements and automatic controls.

External control connections to the transmission are:

1. Manual Linkage - To select the desired operating range.
2. Engine Vacuum - To operate a vacuum modulator.
3. 12-Volt Electrical Signal - To operate an electrical detent solenoid.

A vacuum modulator is used to automatically sense any change in the torque input to the transmission. The vacuum modulator transmits this signal to the pressure regulator, which controls line pressure, so that all torque requirements of the transmission are met and smooth shifts are obtained at all throttle openings.

The detent solenoid is activated by the detent switch. When the throttle is fully open, the switch is closed, activating the detent solenoid and causing the transmission to downshift at speeds below approximately 60 MPH.

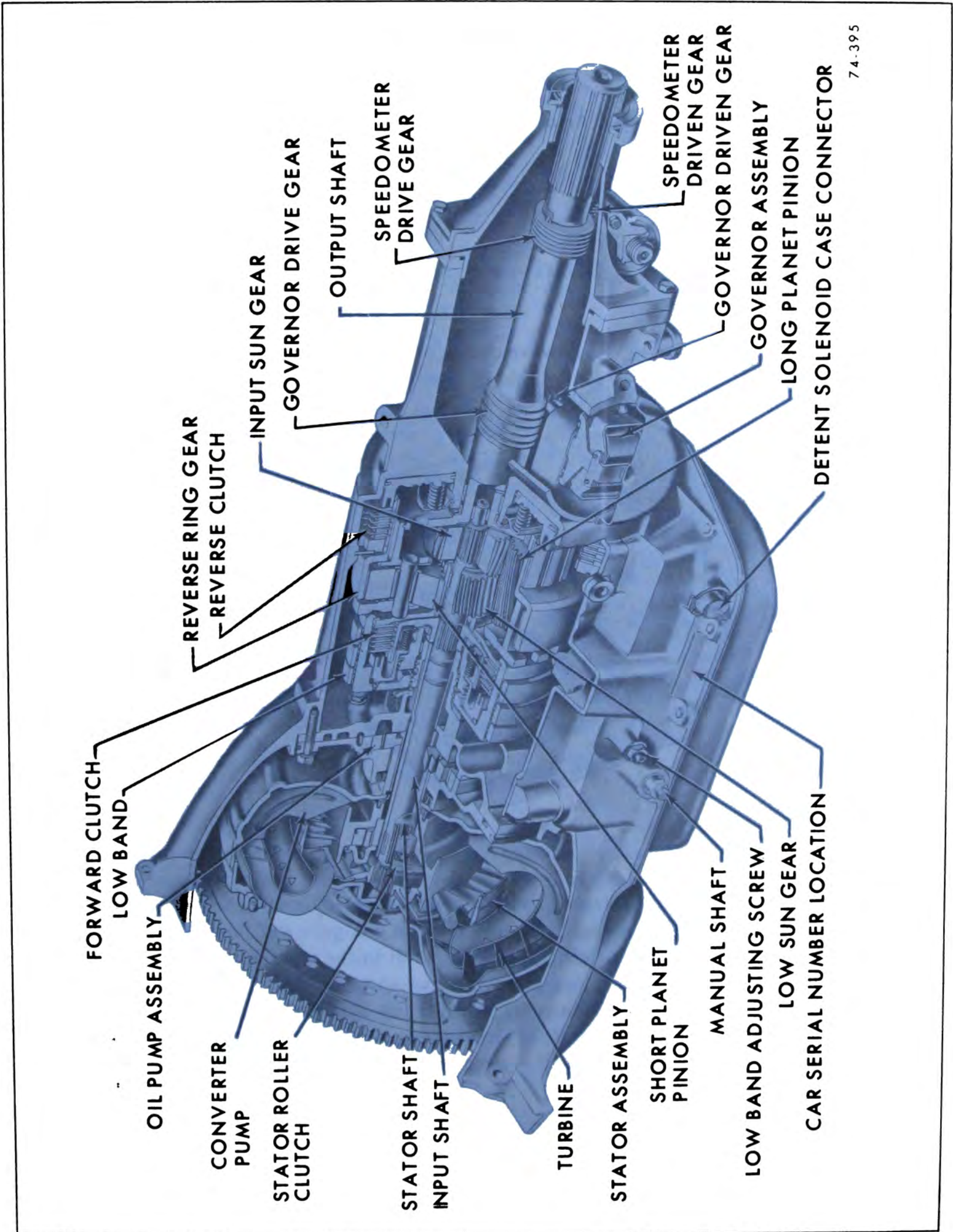

74-395

Figure 74-3—Super Turbine 300 Cross Section

74-5 MECHANICAL OPERATION

1. Operation of Components in Manual or Automatic Low Range

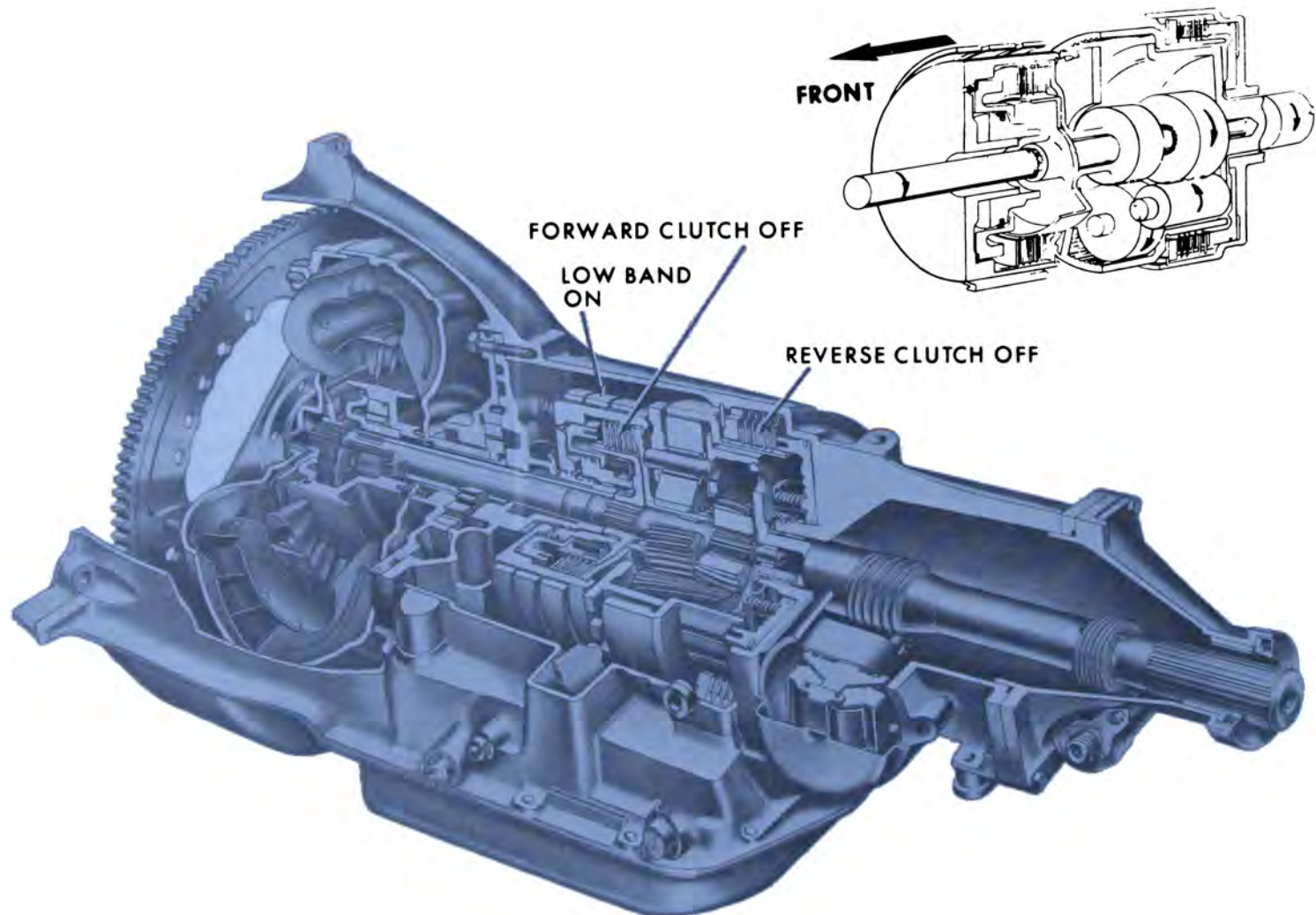

In Low range, the forward clutch is released and the low band is applied to the outside diameter of the forward clutch drum. With the low band applied, the low sun gear and flange assembly is held stationary. Drive is from the converter through the input shaft to the input sun gear in the planetary gear set. The input sun gear drives the long planet pinions which are in mesh with the short planet pinions. Since the low sun gear is held stationary with the low band applied, the short pinions walk around the low sun gear, and as they walk around the sun gear, they carry with them the planet carrier and the output shaft to which they are attached at a reduction of 1.76 to 1.

74-397

Figure 74-4—Operation of Components in Manual Low or Automatic Low

2. Operation of Components in Drive Range

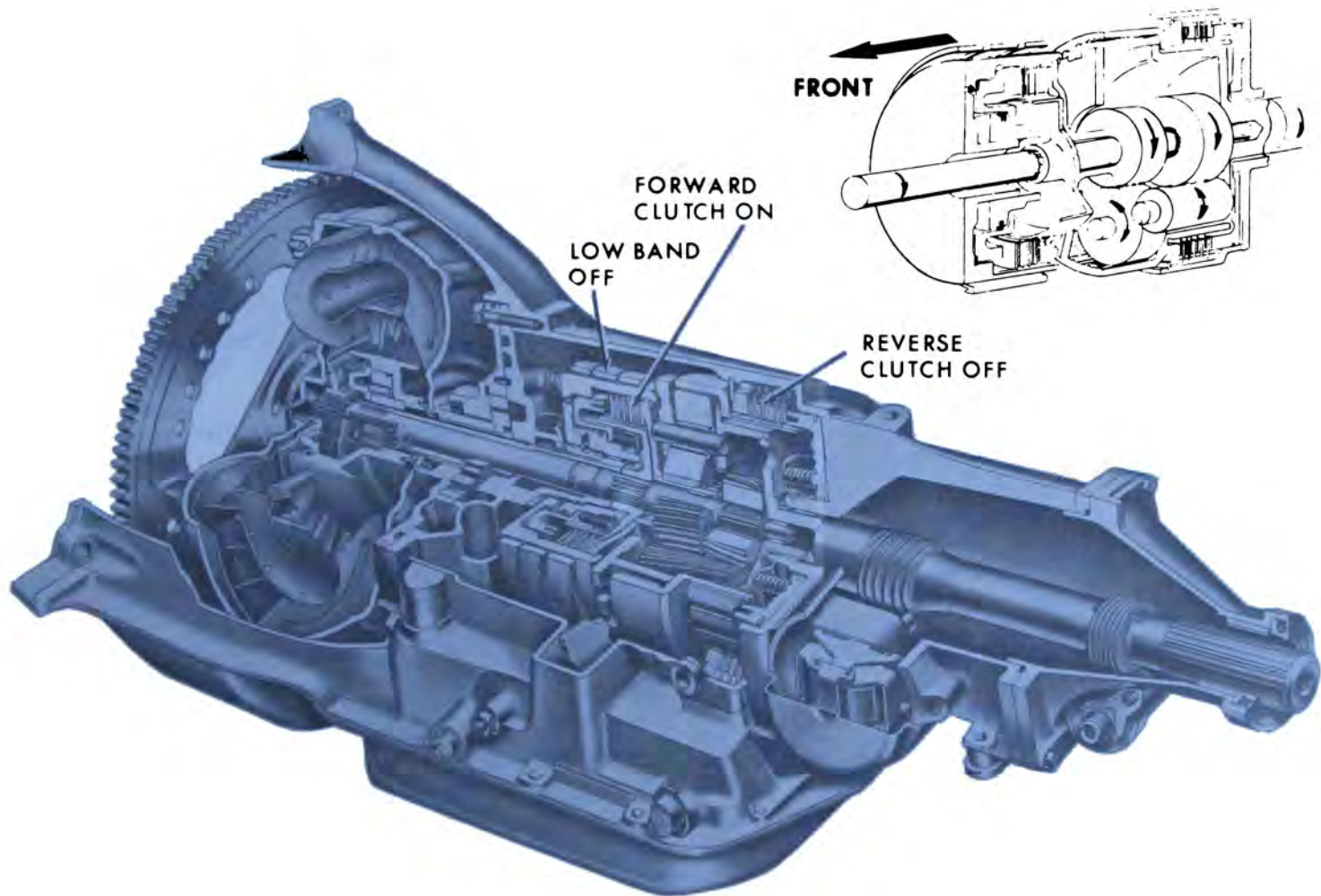

With the manual control lever in Drive range, the transmission is started automatically in Low range. The upshift into Drive range is dependent upon car speed and throttle opening. When the shift occurs, the low band is released and the forward clutch is applied. Application of the forward clutch locks the planetary system causing it to rotate as a unit. With the clutch applied, the clutch hub which is splined to the input shaft is locked to the low sun gear and flange assembly through the clutch plates. The low sun gear is meshed to the short pinions, the short pinions are meshed with the long pinions, and the long pinions are meshed with the input sun gear; the sun gear is also splined to the input shaft. Since both the low sun gear and input sun gear are now locked to the input shaft, the entire planetary unit will revolve at input shaft speed.

74-398

Figure 74-5—Operation of Components in Drive Range

3. Operation of Components in Reverse Range

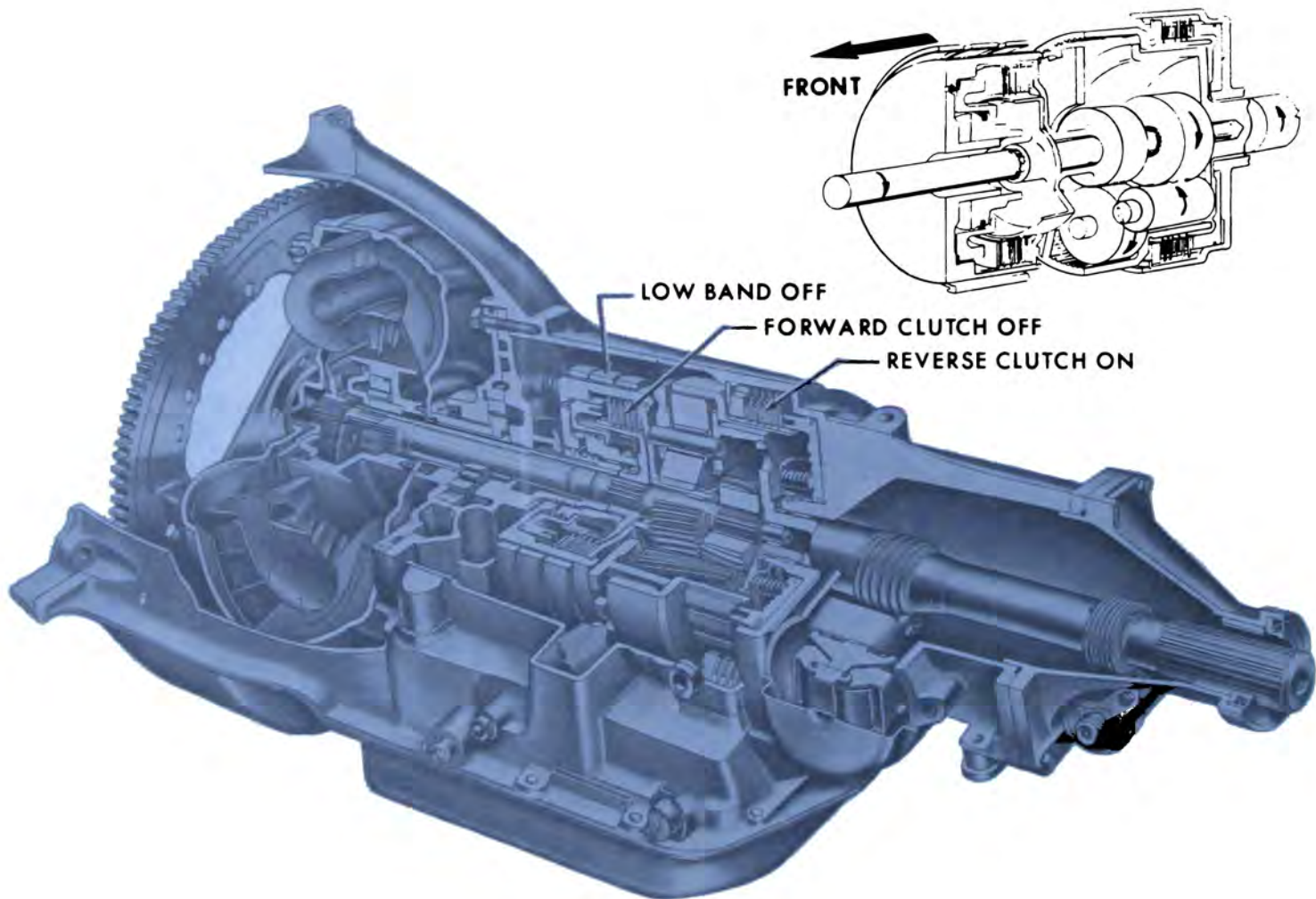

When the manual control lever is in Reverse range, the forward clutch and low band are released, and the reverse clutch is applied, holding the ring gear stationary. Drive is through the input shaft and input sun gear to the long pinions and then to the short pinions. The short pinions mesh with the reverse ring gear which is held stationary by the reverse clutch. The short pinions walk around the inside of the ring gear in a reverse direction, turning the output shaft to which they are attached at a reduction of 1.76 to 1.

74-399

Figure 74-6—Operation of Components in Reverse Range

4. Operation of Components in Neutral Position

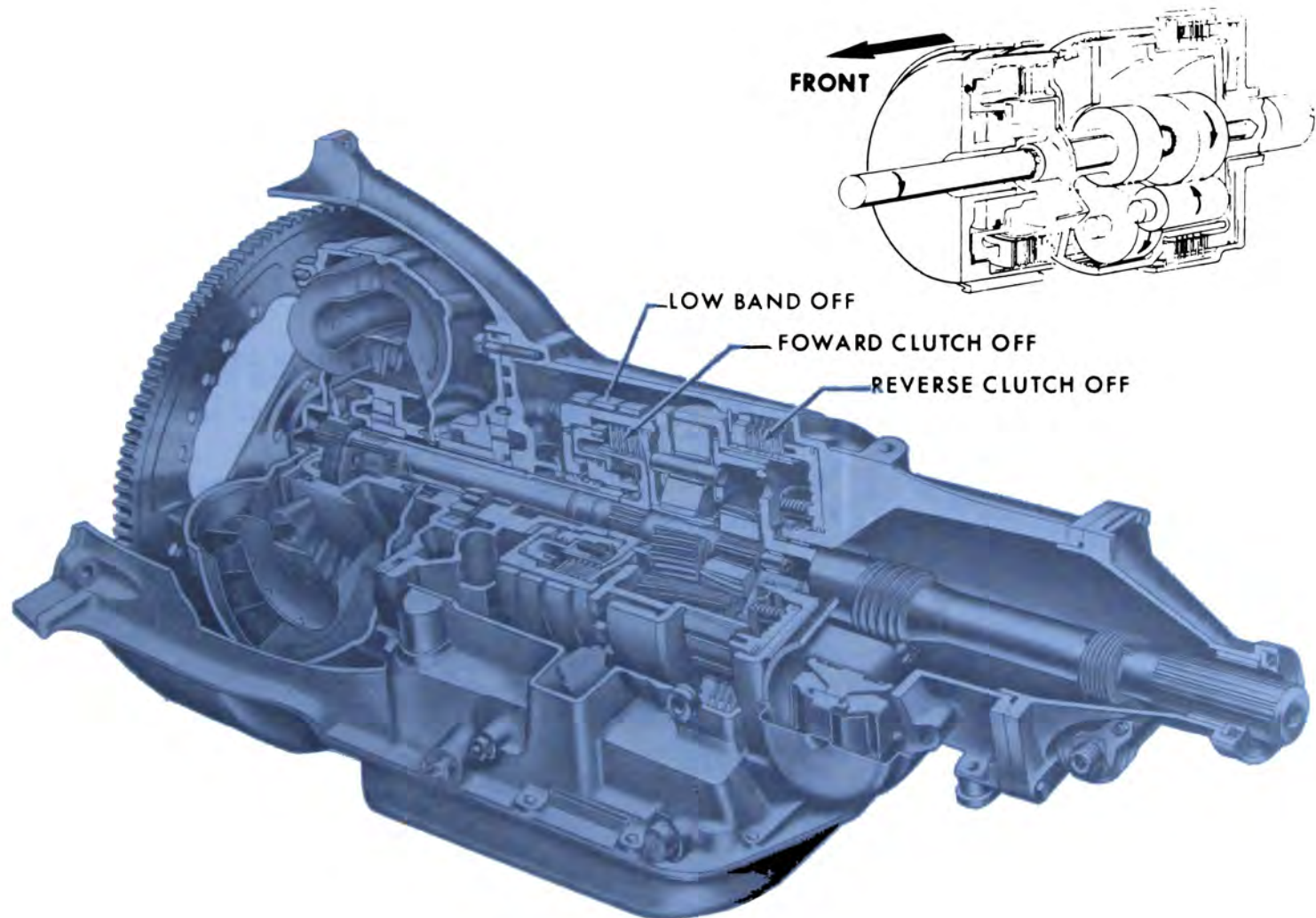

With the shift control lever in Neutral position, the output shaft remains stationary. The clutches and low band are released; therefore, there is no reaction member to provide positive drive. All gears are free to spin around their own axis, and no motion is imparted to the planet carrier.

74-400

Figure 74-7—Operation of Components in Neutral Position

5. Operation of Components in Park Position

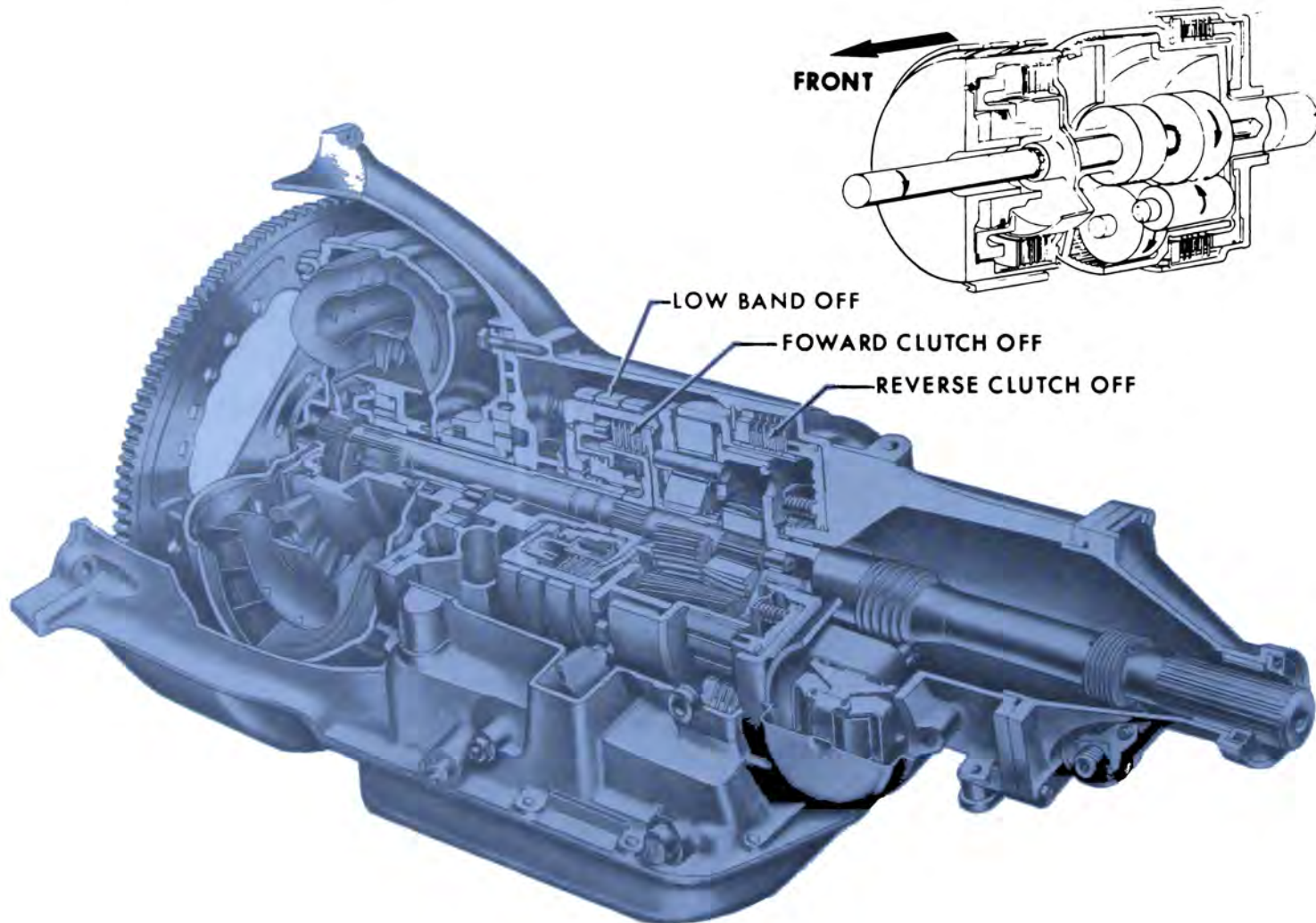

In Park Position, all reaction members are released as in Neutral. A positive gear train lock is provided when the parking pawl is engaged with the heavy teeth spaced around the front face of the planetary carrier. The linkage is actuated by direct manual action, but the parking pawl is activated by spring action. If the pawl is in line with a tooth of the planet carrier, rather than a spacer between teeth, the linkage remains in the park position with the spring holding pressure against the pawl. Slight rotation of the planet carrier will immediately seat the pawl and lock the output shaft to the case.

74-401

Figure 74-8—Operation of Components in Park Position

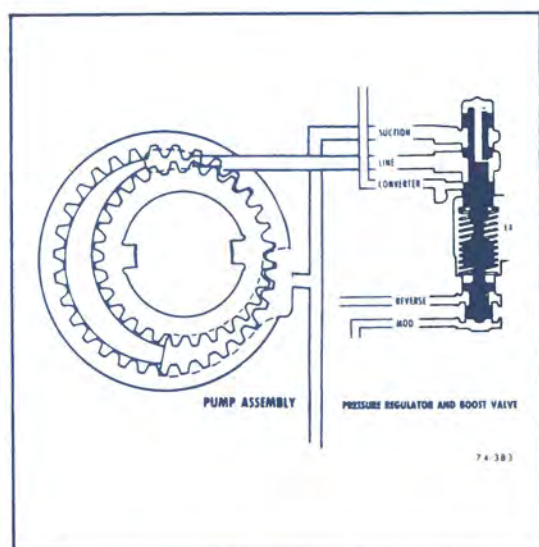

Figure 74-10—Oil Pump Pressure Regulator Valve

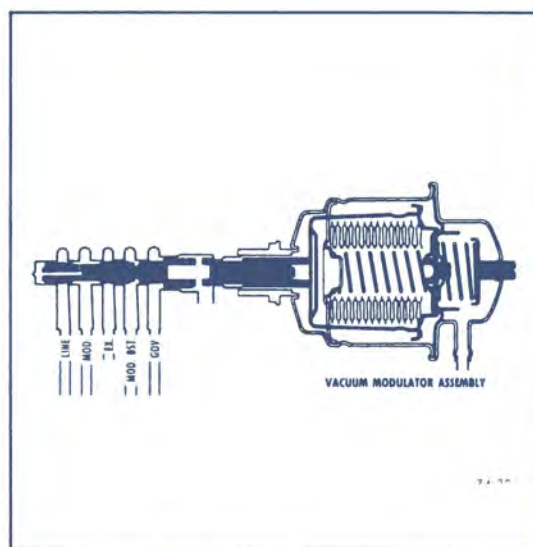

Figure 74-11—Vacuum Modulator Assembly

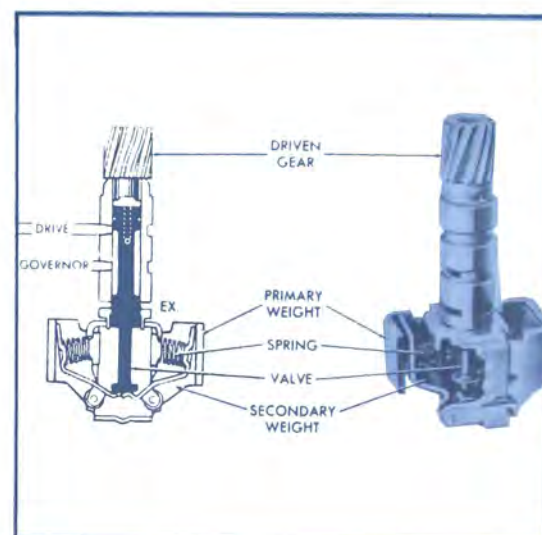

Figure 74-12—Governor Assembly

74-6 FUNCTIONS OF VALVES AND HYDRAULIC CONTROL UNITS

a. Pressure Control

The transmission is controlled automatically by a hydraulic system. Hydraulic pressure is supplied by the transmission oil pump, See figure 74-10, which is engine driven. Main line pressure is controlled by a pressure regulator valve train and by the vacuum modulator which is connected to engine vacuum. The pressure regulator valve train controls line pressure automatically, in response to a pressure signal from a modulator valve, in such a way that the torque requirements of the transmission clutches are met and proper shift spacing is obtained at all throttle openings.

To control line pressure properly, a modulator pressure is used which varies in the same manner as torque input to the transmission. Modulator pressure is regulated by engine vacuum, which is an indicator of engine torque and carburetor opening.

b. Vacuum Modulator Assembly

The engine vacuum signal is provided by the vacuum modulator, which consists of an evacuated

metal bellows, a diaphragm and two springs. See figure 74-11. These are so arranged that when installed, the bellows and its external spring apply a force which acts on the modulator valve. This force acts on the modulator valve so that it increases modulator pressure. Engine vacuum and the other spring acts in the opposite direction to decrease modulator, or low engine vacuum, high modulator pressure; high engine vacuum, and low modulator pressure.

To reduce the effect of engine power loss at high altitudes on shift points, the effective area of the diaphragm is made somewhat larger than that of the bellows. Atmospheric pressure then acts on the resulting differential area to reduce modulator pressure.

c. Governor Assembly

The vehicle speed signal to the modulator valve is supplied by the transmission governor, which is driven by the output shaft. The governor consists of a pair of dual weights and a regulator valve. See Figure 74-12.

As the car begins to move the weight assemblies move outward to provide a regulating force against the valve through the springs between the primary and secondary weights. As car speed

is further increased, regulating force against the valve is provided by the secondary weights moving outward. At approximately 19 MPH the primary weights have reached the limit of their travel and the force against the valve is then entirely through the secondary weights.

Thus, governor valve pressure is determined at very low speeds by the primary and secondary weights and at higher speeds by the secondary weights plus the force of the springs between the weights. In this manner governor pressure is increased rapidly but smoothly from very low speeds to approximately 19 MPH, where it increases at a slower rate.

d. Pressure Regulator Valve (See Figure 74-10)

1. Regulates line pressure according to a fixed spring force and forces controlled by modulator and reverse pressure.
2. Controls flow of oil that charges the torque converter, and feeds the oil cooler and provides lubrication for the transmission.

e. Manual Valve (See Figure 74-13)

Establishes the range of transmission operation, i.e., P, R, N,

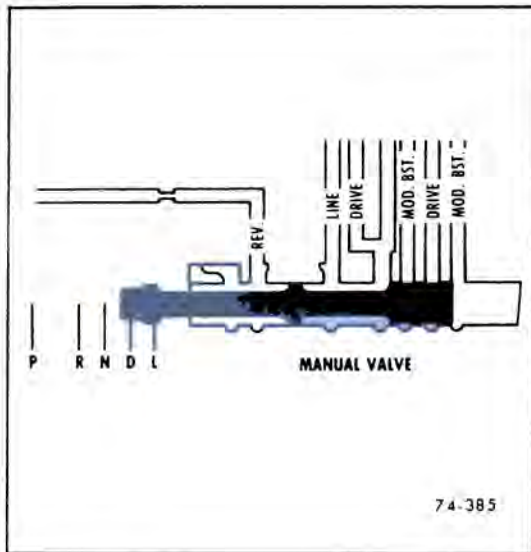

Figure 74-13—Manual Valve

D, L, as selected by the vehicle operator through the manual selector lever.

f. Modulator Valve (See Figure 74-14)

Regulates line pressure to modulator pressure that varies with torque to the transmission. It senses forces created by:

1. The vacuum modulator bellows that increases modulator pressure.
2. Engine vacuum acting on a diaphragm to decrease modulator pressure.
3. Governor pressure which is generated by the governor as-

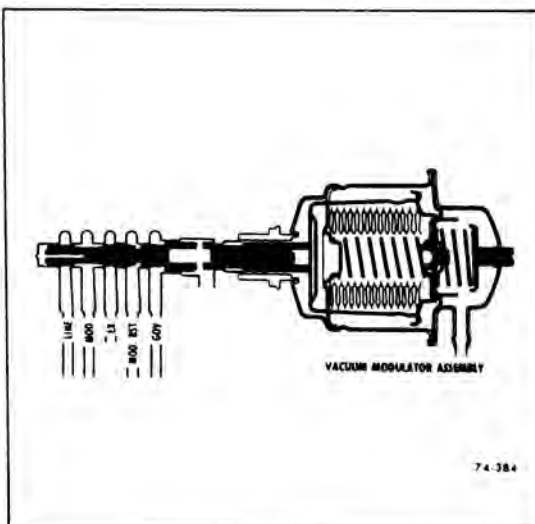

Figure 74-14—Modulator Valve

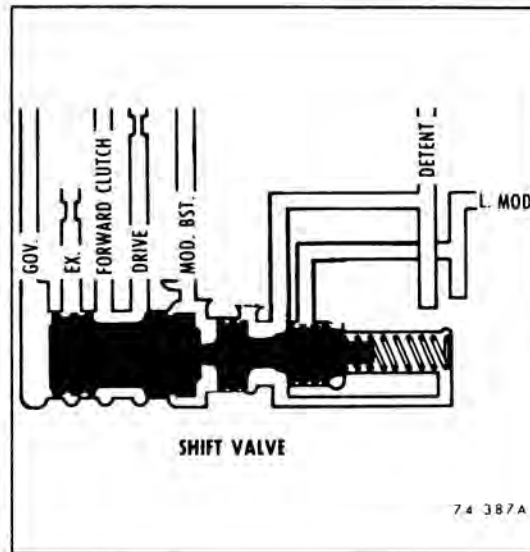

Figure 74-15—Shift Valve and Shift Control Valve

sembly. Governor pressure tends to decrease modulator pressure.

g. Shift Valve and Shift Control Valve (See Figure 74-15)

The shift valve and shift control valve are housed together in the valve body. They interpret oil pressure from the governor and vacuum modulator valve to the shift from automatic low to drive range or from drive to automatic low.

h. Detent Valve (See Figure 74-16)

The detent valve is a solenoid operated two position valve that provides a downshift at wide open throttle providing car speed is low enough.

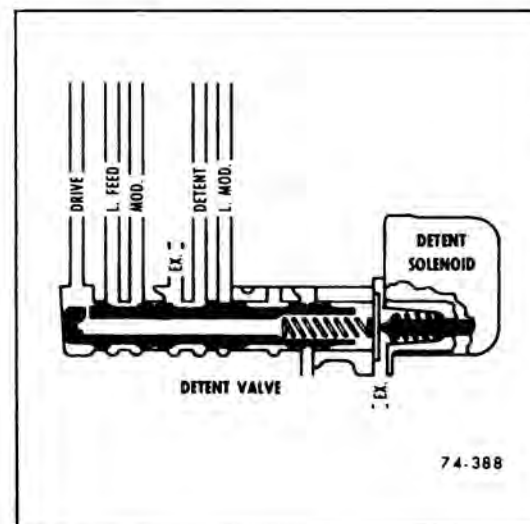

Figure 74-16—Detent Valve

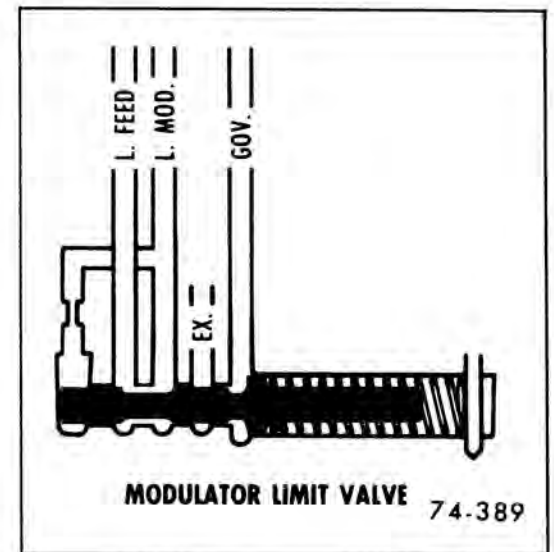

Figure 74-17—Modulator Limit Valve

i. Modulator Limit Valve (See Figure 74-17)

The modulator limit valve is a pressure regulator valve that regulates the point at which a wide open throttle upshift will occur.

j. Low Servo (See Figure 74-18)

The low servo is housed in the transmission case. Its function is to apply the low band. It also acts as a pressure accumulator for the forward clutch during upshifts and downshifts.

k. High Speed Downshift Timing Valve

The high speed downshift timing valve is a spring loaded valve located in the valve body. The

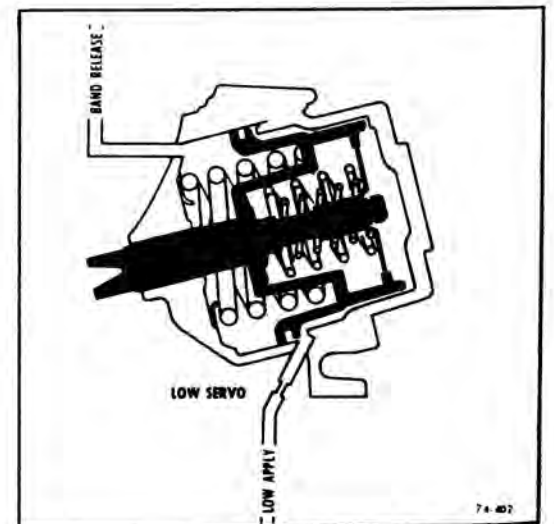

Figure 74-18—Low Servo

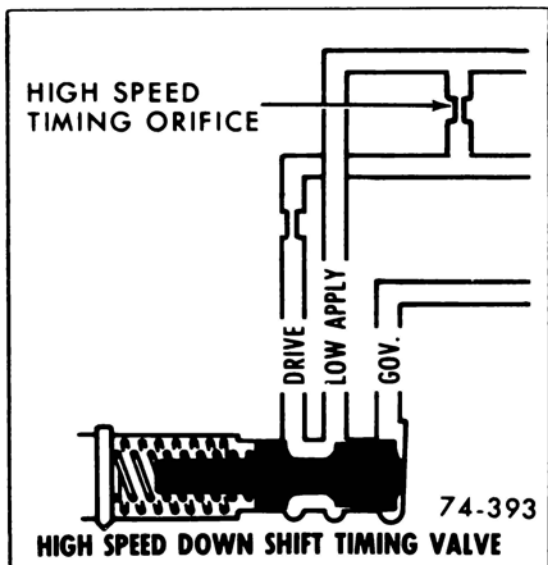

Figure 74-20—High Speed Downshift Timing Valve - First Stage Regulation

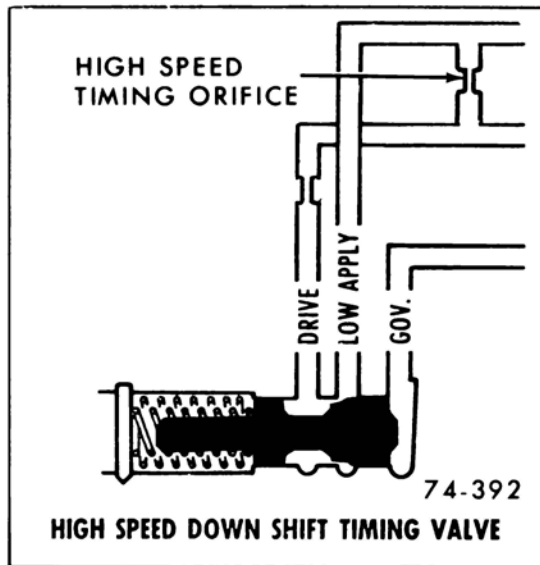

Figure 74-21—High Speed Downshift Timing Valve - Second Stage Regulation

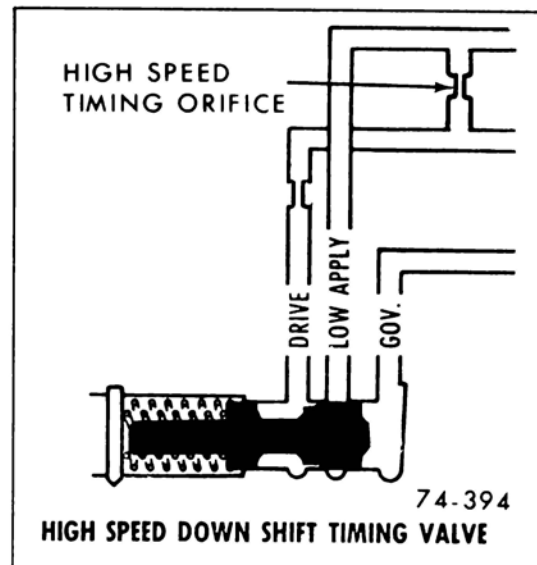

Figure 74-22—High Speed Downshift Timing Valve - Third Stage Regulation

valve meters the rate of oil flow to the low servo through the whole speed range by use of three orifices to provide proper rate of low band application.

At lower car speeds, governor pressure is not sufficient to overcome the high speed downshift valve springs. Oil is then allowed to flow unrestricted by the valve to the orifice at the low servo. See Figure 74-20.

As car speed increases governor pressure on the end of the valve increases to overcome the force of one spring. The valve will then begin to move to the left as shown in Figure 74-21. With the valve in this position oil has to flow simultaneously around the flats on the number 1 land of the valve (which acts as an orifice) and through the high speed timing orifice before flowing through the orifice at the low servo to apply the low band.

At higher car speeds governor pressure on the end of the valve increases to overcome force of two (2) springs. The valve will then move over to the retaining pin. See Figure 74-22. This prohibits oil from passing through the valve and allows it to pass through the high speed timing orifice only before flowing through

the orifice at the low servo to apply the low band.

l. Coast Downshift Timing Valve (See Figure 74-23)

As the car is decelerating with closed throttle or very light throttle (such as when approaching a stop) governor pressure diminishes to a point where spring pressure moves the shift valve to the downshift position. When this occurs, oil is exhausted from the band release chamber of the low servo through the coast downshift timing valve.

A rush of oil through the valve moves the ball retainer and ball

against light spring pressure off its seat, oil may then escape around the ball retainer and spring. This action cushions the initial engagement of the low band.

m. Converter Blow Off Valve (See Figure 74-24)

The converter blow off valve is located in the pump cover and stator shaft assembly. The valve consists of a relief ball, spring, and retaining pin. When converter pressure reaches 150 psi the relief ball opens a port and exhausts converter pressure. Therefore, converter pressure is never allowed to go above 150 psi valve.

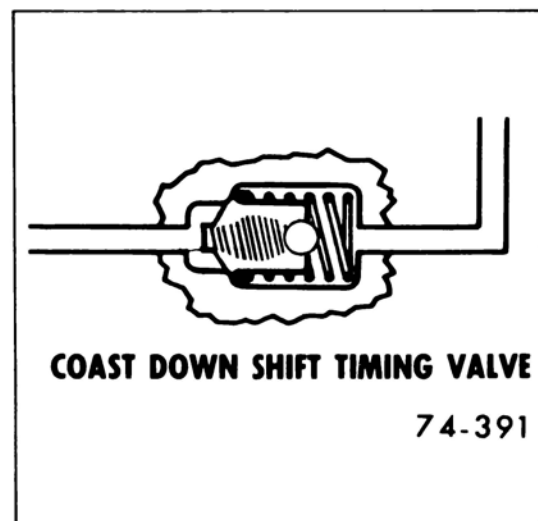

Figure 74-23—Coast Downshift Timing Valve

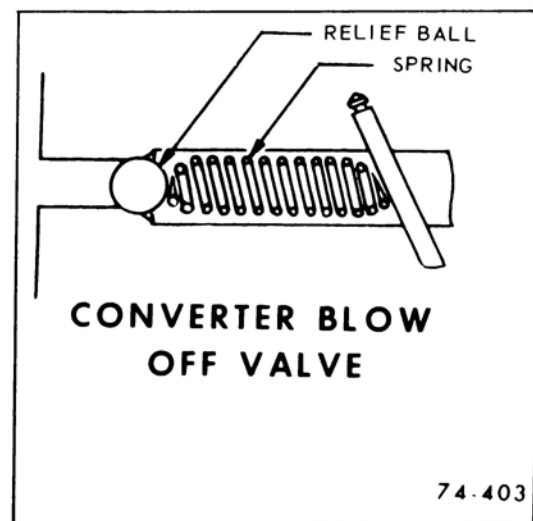

Figure 74-24—Converter Blow-Off Valve

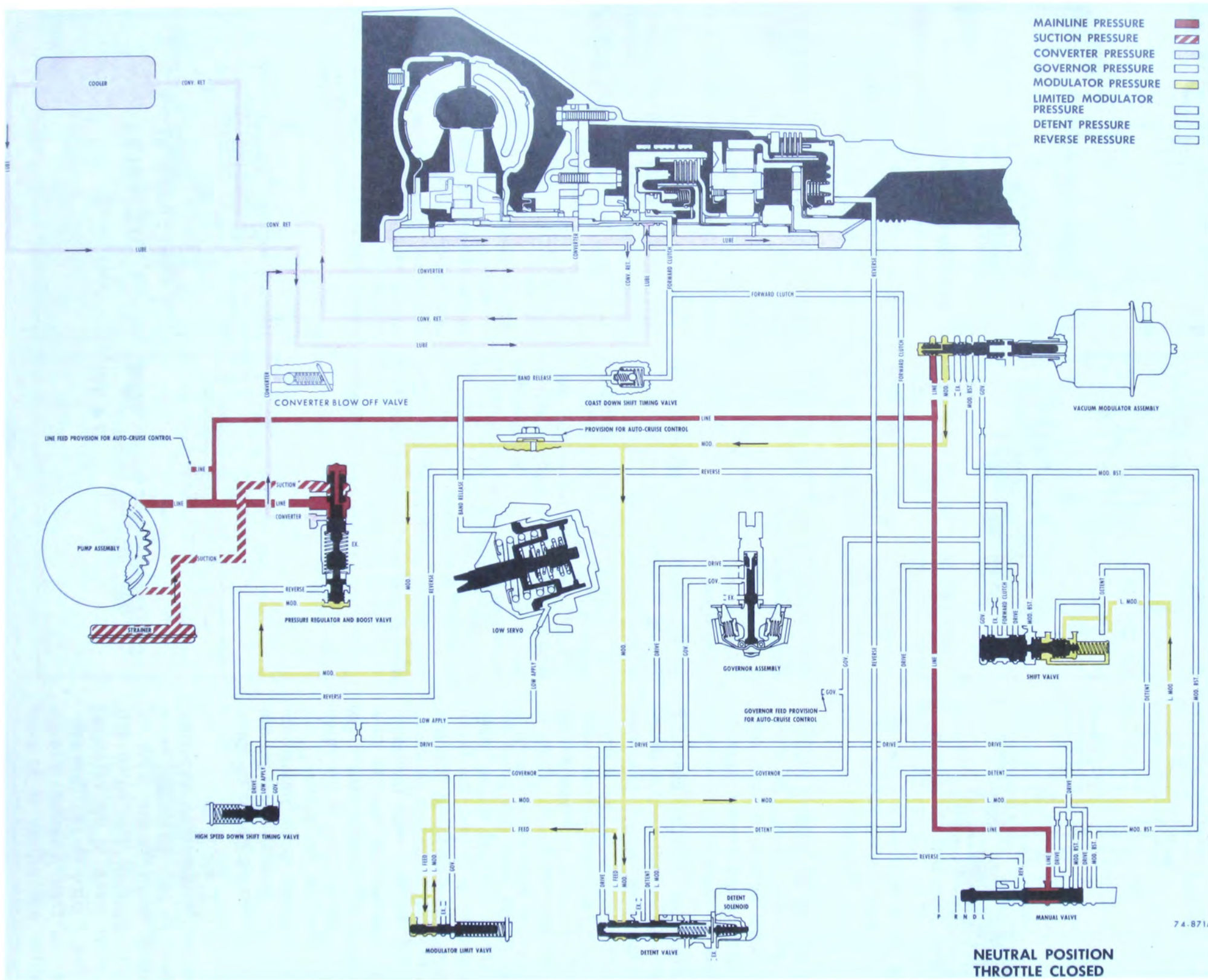

Figure 74-25—Park or Neutral (Throttle Closed)

a. Operation of Controls Park or Neutral (Throttle Closed)

Low Band - OFF Forward Clutch - OFF Reverse Clutch - OFF

Detent Solenoid - DE - energized

During operation in Neutral position, the manual shift control valve is positioned as shown in Figure 74-25. Main line oil is directed to the manual shift control valve and the vacuum modulator. Main line oil being directed to the modulator valve enters between the first and second lands. At low engine vacuum the vacuum modulator tends to keep the valve toward the bottom of its bore. In this position oil is delivered through a drilled passage in the valve to the space between the first land of the valve and the valve body. Oil under pressure in this area tends to move the valve against the force of its spring to regulate modulator oil pressure leaving the valve. Modulator oil leaves the modulator valve and is routed to the boost valve, detent valve, modulator limit valve, and to the shift control valve. Modulator pressure applies a force to the space between the first land of the boost valve and the oil pump body causing it to move to the right. As the boost valve moves to the right it contacts the pressure regulator valve. This hydraulic force combined with normal spring force on the pressure regulator valve results in higher main line pressure.

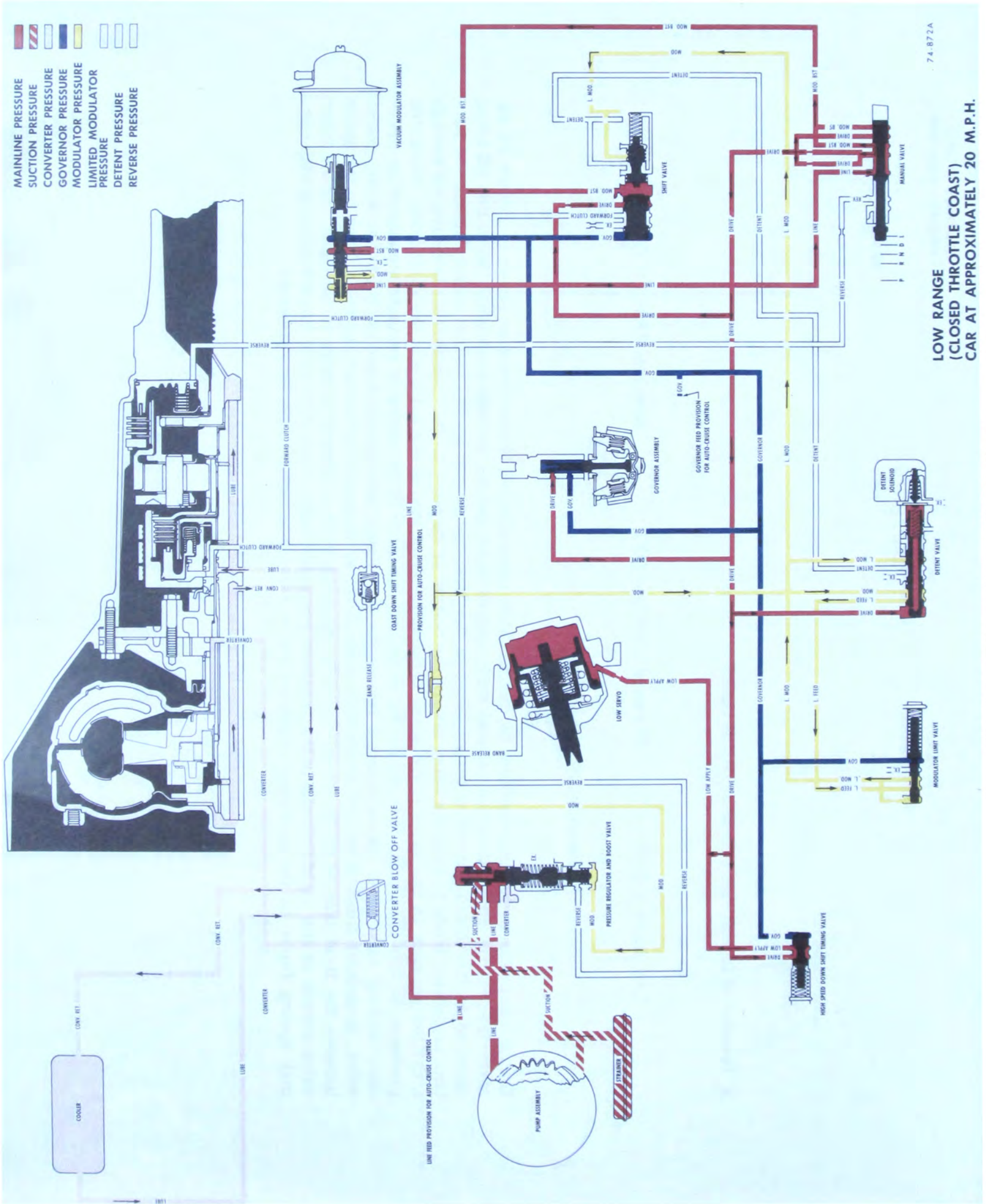

Figure 74-26—Low Range Closed Throttle Coast

b. Operation of Controls Low Range (Closed Throttle Coast)

Low Band - ON Forward Clutch - OFF Reverse Clutch - OFF

Detent Solenoid - DE - Energized

During operation in Low range, the manual shift control valve is positioned as shown in Figure 74-26. During a closed throttle coast in low range, main line oil is directed to the modulator valve and the manual shift control valve. Main line oil entering the manual shift control valve is routed into drive oil passage and modulator boost passage. Oil routed in the drive oil passage is directed to the governor valve, shift valve, and detent valve, high speed down shift timing valve and low servo. Oil routed in the modulator boost passage is directed to the shift valve and vacuum modulator valve. Modulator boost oil enters the shift valve between the shift valve and the shift control valve, moving the shift valve to the left and holding it in the bottom of its bore thus exhausting the forward clutch. Modulator boost oil at the vacuum modulator valve causes an increase in regulated modulator pressure. This higher modulator pressure boosts line pressure to a pre-determined value, to smooth out low engagement as the shift lever is positioned in this range at moderate vehicle speed. Drive oil directed from the manual shift control valve applies the low servo. With the manual control lever in Low "L" range the transmission will not upshift into direct drive.

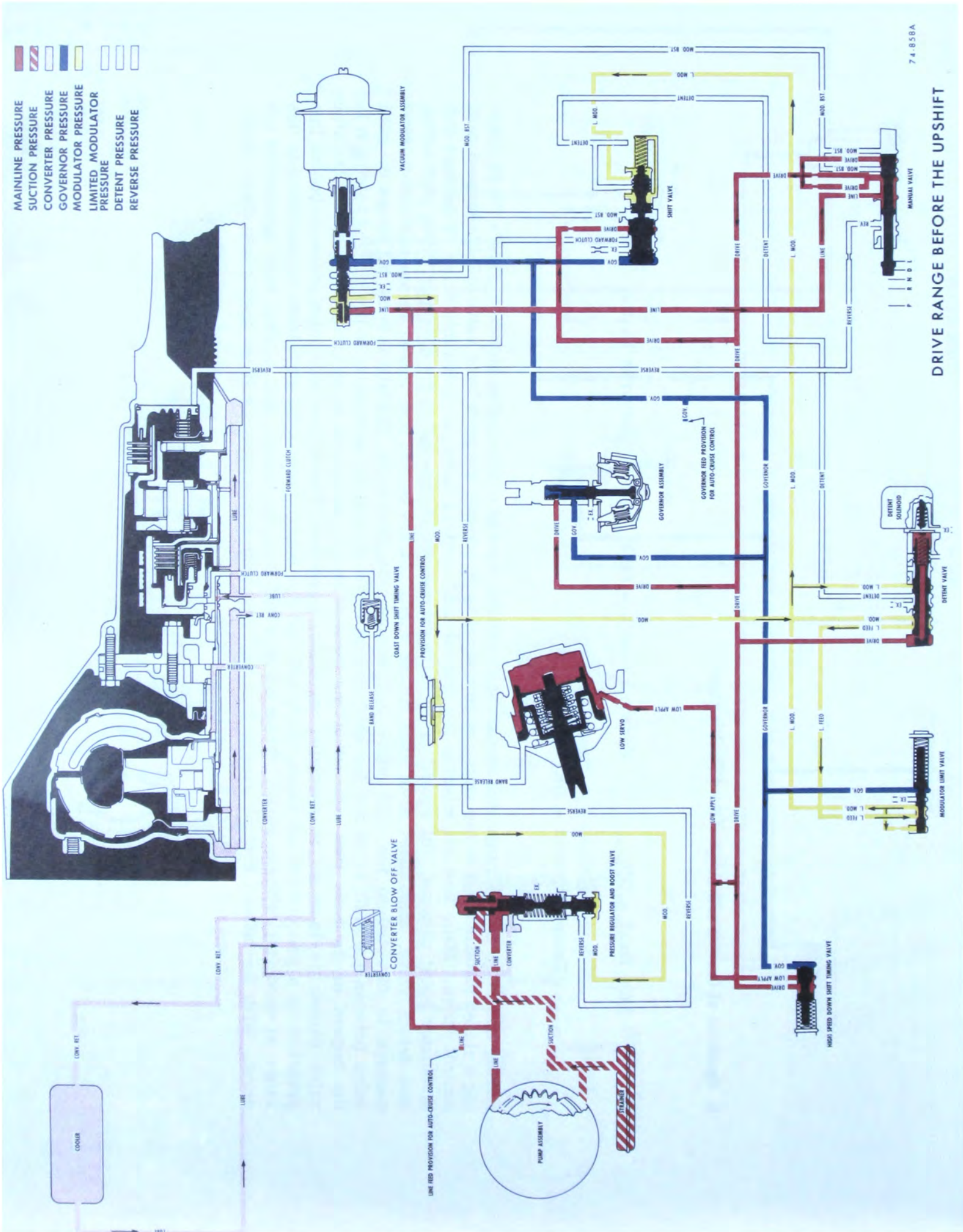

Figure 74-27—Drive Range Before the Upshift

c. Operation of Controls Drive Range Before Upshift

Low Band - OFF Forward Clutch - ON Reverse Clutch - OFF

Detent Solenoid - DE - Energized

During operation in Drive range the manual shift control valve is positioned as shown in Figure 74-27. During an acceleration, main line oil is directed to the modulator valve and manual shift control valve. Main line oil entering the manual shift control valve is routed into the drive oil passage and then directed to the governor valve, shift valve, detent valve, high speed down shift timing valve and the low servo applying the low band.

Main line oil being directed to the modulator valve enters between the first and second lands. At low engine vacuum the vacuum modulator tends to keep the valve toward the bottom of its bore. In this position oil is delivered through a drilled passage in the valve to the space between the first land of the valve and the valve body. Oil under pressure in this area plus governor pressure on the second land of the second modulator valve tends to move the valve against the force of its spring to regulate modulator oil pressure leaving the valve. Modulator oil leaves the modulator valve and is routed to the boost valve, detent valve, modulator limit valve, and to the shift control valve. Modulator pressure applies a force to the space between the first land of the boost valve and the oil pump body causing it to move to the right See Figure 74-27. As the boost valve moves to the right it contacts the pressure regulator valve. This hydraulic force combined with normal spring force on the pressure regulator valve results in higher main line pressure.

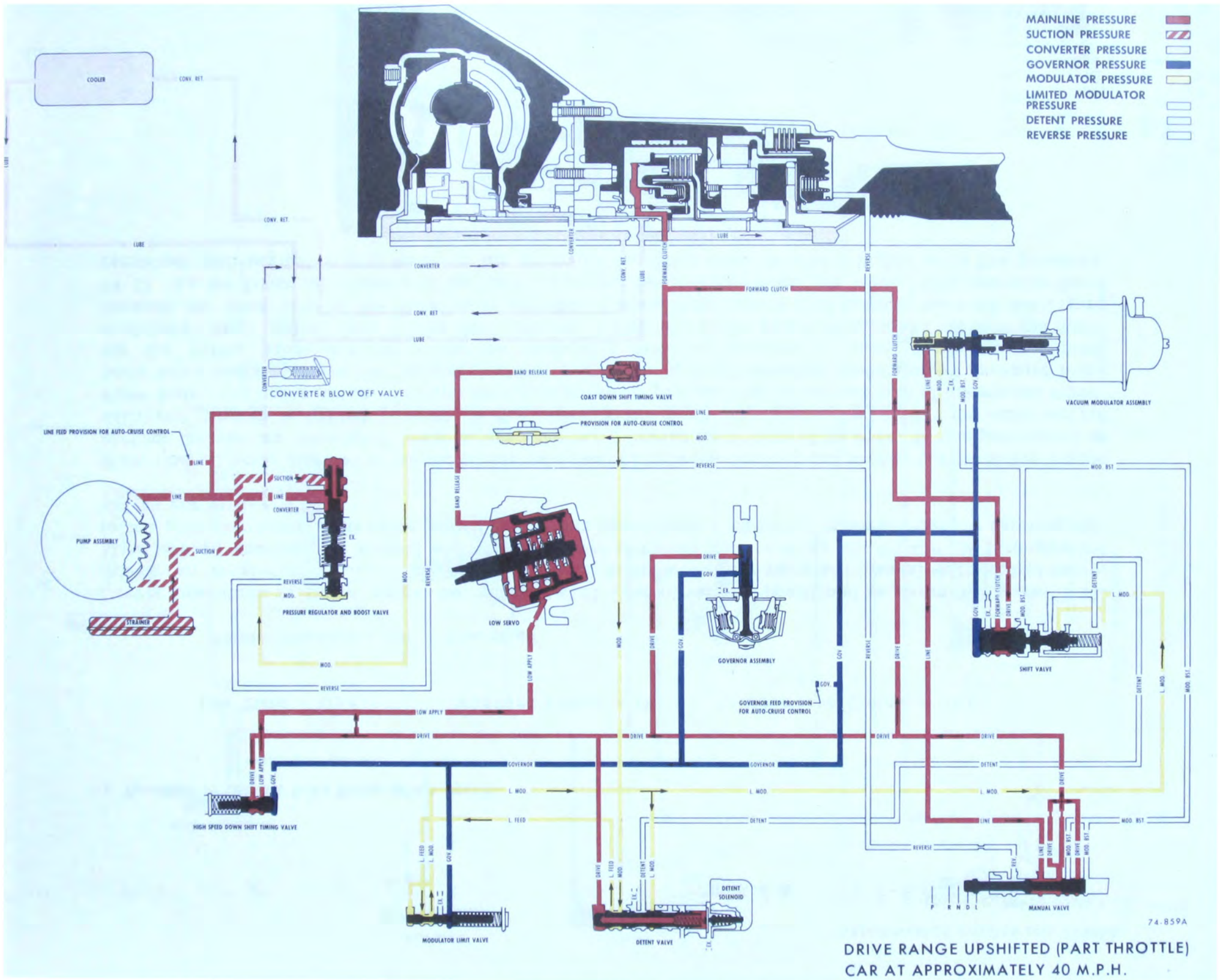

Figure 74-28—Drive Range Upshifted (Part Throttle)

d. Operation of Controls Drive Range Upshifted (Part Throttle)

Low Band - OFF Forward Clutch - ON Reverse Clutch - OFF

Detent Solenoid - DE - Energized

When sufficient car speed has been obtained, the governor valve will regulate allowing drive oil to be directed at regulated pressure to the space between the first land of the shift valve and the valve body, on the second land of the second modulator valve, between the second and third lands of the modulator limit valve, and in the space between the first land of the high speed down shift timing valve and the valve body. As governor pressure is received on the second land of the second modulator valve it will tend to move the valve against its spring, reducing modulator pressure.

As both vehicle speed and governor pressure increase, the force of governor pressure acting on the shift valve will overcome modulator pressure and the spring force of the shift control valve. This allows the shift valve to move to the right allowing drive oil to apply the forward clutch and release the low band.

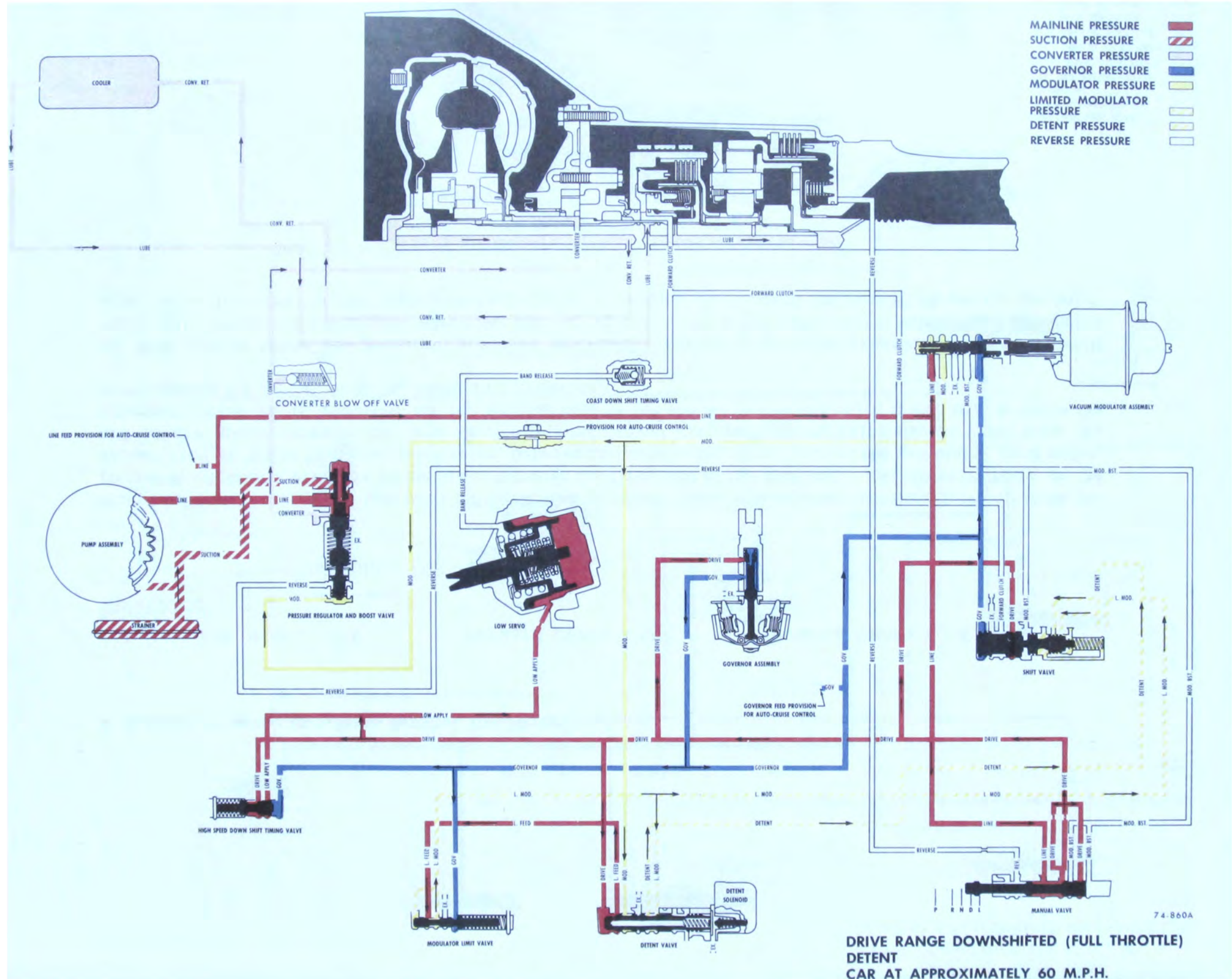

Figure 74-30—Drive Range Downshifted (Full Throttle)

**e. Operation of Controls Drive Range Downshifted
(Full Throttle)**

Low Band - ON

Forward Clutch - OFF

Reverse Clutch - OFF

Detent Solenoid - Energized

During operation in Drive range at full throttle, the detent valve solenoid is energized. The manual shift control valve is positioned as shown in Figure 74-30.

Energization of the detent solenoid allows oil from the center of the valve to flow to exhaust. Drive oil applying force to the area between the valve body and the first land of the valve moves the valve against its spring pressure to the bottom of its bore.

During a full-throttle acceleration main line oil is directed to the modulator valve and manual shift control valve. Main line oil entering the manual shift control valve is routed into the drive oil passage and then directed to the governor valve, shift valve, detent valve, high speed down shift timing valve, and modulator limit valve, and low servo.

Main line oil directed to the modulator valve enters between the first and second lands. Oil pressure in the space between the valve and the valve body plus governor pressure on the second land of the second modulator valve tend to move the valve against the force of its spring to regulate oil pressure leaving the valve.

Modulator pressure applies force to the left end of the boost valve causing it to move to the right. As the boost valve moves to the right it contacts the pressure regulator valve. This hydraulic force combined with normal spring force on the pressure regulator valve results in a high main line pressure. With the detent valve solenoid energized, drive oil pressure enters into the limited feed line. When limited feed pressure reaches a high enough value and exerts enough force to overcome spring force on the modulator limit valve, the valve will regulate governing the limited modulator and detent pressure to the shift control valve. Detent pressure, limited modulator pressure, plus the force of the shift control valve spring overcome governor pressure and move the shift valve assembly to the left exhausting the forward clutch.

As higher governor pressure is reached it acts on in the area between the valve body and the first land of the high speed down shift timing valve until governor pressure overcomes spring pressure and moves the valve to the left. This movement blocks the nonrestricted line, routing the servo apply oil through the restricted orifices. On a down shift this restriction of flow causes the band apply to be delayed slightly and is thus timed to the forward clutch release for a smooth down shift.

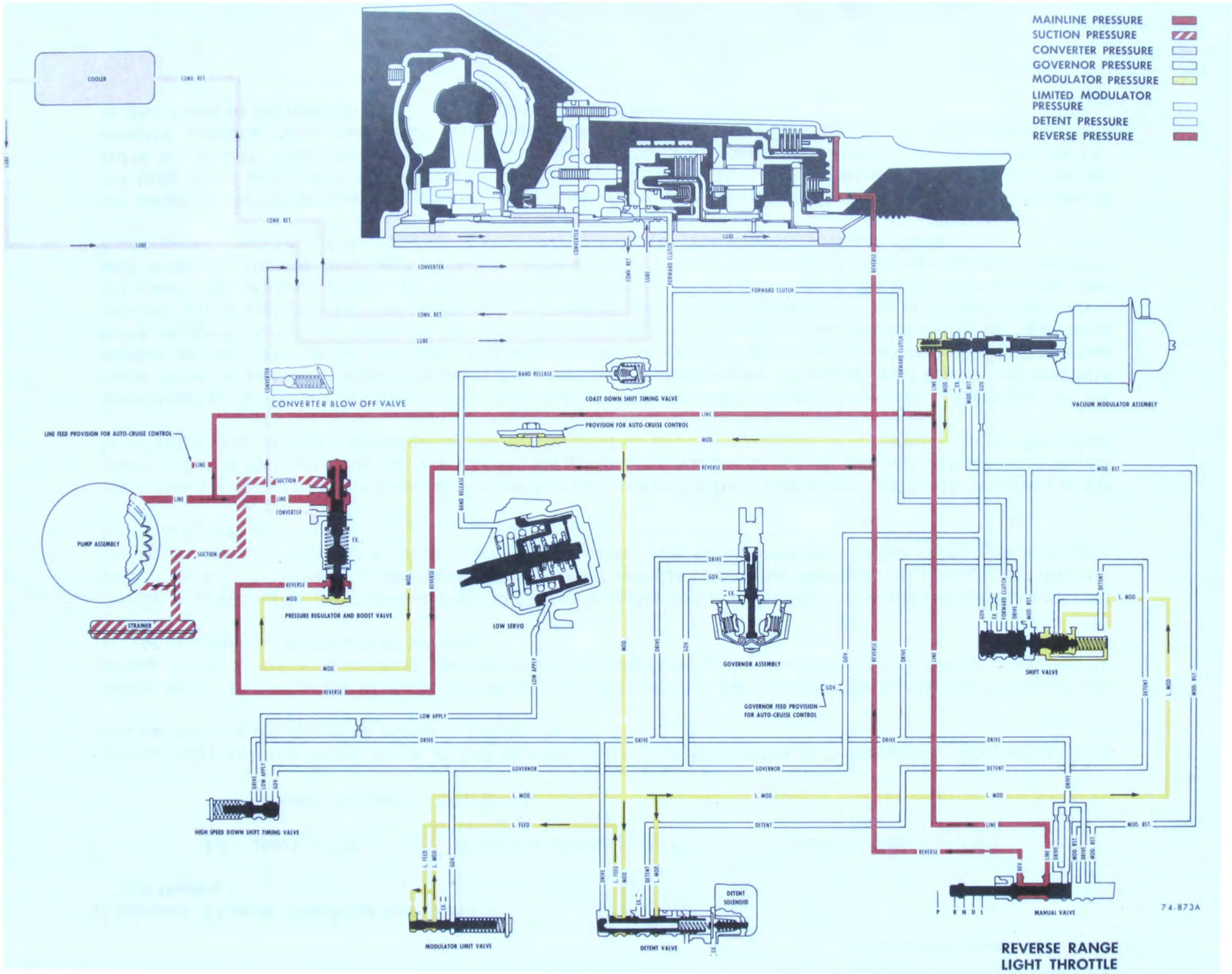

Figure 74-31—Reverse Range (Light Throttle)

f. Operation of Controls in Reverse (Light Throttle)

Low Band - OFF Forward Clutch - OFF Reverse Clutch - ON

Detent Solenoid - DE - Energized

During operation in Reverse range the manual shift control valve is positioned as shown in Figure 74-31. During light throttle in reverse, main line oil is directed to the vacuum modulator valve and the manual shift control valve. Main line oil entering the manual shift control valve is directed to the reverse clutch and between the 1st and 2nd lands of the boost valve. Main line pressure applies a force to the 2nd land of the boost valve causing it to move to the right. As the boost valve moves to the right it contacts the pressure regulator valve. Main line oil being directed to the modulator valve enters between the first and second lands. At low engine vacuum the vacuum modulator tends to keep the valve toward the bottom of its bore. In this position oil is delivered through a drilled passage in the valve to the space between the first land of the valve and valve body. Oil under pressure in this area tends to move the valve against the force of its spring to regulate modulator oil pressure leaving the valve. Modulator oil leaves the modulator valve and is routed to the boost valve, detent valve, modulator limit valve, and to the shift control valve. Modulator pressure applies a force to the space between the first land of the boost valve and the oil pump body causing it to move to the right. As the boost valve moves to the right it contacts the pressure regulator valve. This hydraulic force plus main line pressure on the second land of the boost valve combined with normal spring force on the pressure regulator valve results in higher main line pressure needed for reverse operation.

DIVISION III

SERVICE PROCEDURES

74-8 TRANSMISSION ASSEMBLY— REMOVAL AND INSTALLATION

a. Removal

1. Raise car and provide support for front and rear of car.
2. Disconnect front exhaust crossover pipe if necessary.
3. Remove propeller shaft.
4. Place suitable jack under transmission and fasten transmission securely to jack.
5. Remove vacuum line from vacuum modulator. See Figure 74-100.
6. Loosen cooler line nuts and separate cooler lines from transmission. See Figure 74-101.
7. Remove transmission mounting pad to cross member bolts.
8. Remove transmission cross member support to frame rail bolts. Remove cross member.
9. Disconnect speedometer cable and detent solenoid wire from case connector.
10. Disconnect shift linkage from transmission.
11. Disconnect transmission filler pipe at engine. Remove filler pipe from transmission. See Figure 74-100.
12. Support engine at oil pan.
13. Remove transmission flywheel cover pan to case tapping screws. Remove flywheel cover pan.
14. Mark flywheel and converter for reassembly in same position, and remove three converter to flywheel bolts.
15. Assemble transmission to suitable transmission jack and

remove transmission case to engine block bolts.

16. Move transmission rearward to provide clearance between converter pump and crankshaft. Install converter holding Tool J-21366 to retain converter. Lower transmission and move to bench.

b. Installation

1. Assemble transmission to suitable transmission jack and raise transmission into position. Remove converter holding Tool J-21366. Rotate converter to permit coupling of flywheel and converter with original relationship.
2. Install transmission case to engine block bolts. Torque to 30-40 lb. ft. Do not overtighten.
3. Install flywheel to converter bolts. Torque to 25-35 lb. ft.
4. Install transmission cross member support. Install mounting pad.
5. Remove transmission jack and engine support.
6. Install transmission flywheel cover pan with tapping screws.
7. Install transmission filler pipe using a new "O" ring. See Figure 75-100.
8. Reconnect speedometer cable and detent solenoid wire to case connector.
9. Install propeller shaft.
10. Reinstall front exhaust crossover pipe if removed.
11. Install oil cooler lines to transmission. See Figure 74-101.
12. Install vacuum line to vacuum modulator. See Figure 74-100.
13. Fill transmission with fluid as described in Paragraph 74-1 Subparagraph c.

74-9 PRELIMINARY INSTRUCTIONS

1. Before starting disassembly of the transmission it should be thoroughly cleaned externally to avoid getting dirt inside.
2. Place transmission on a CLEAN work bench and use CLEAN tools during disassembly. Provide CLEAN storage space for parts and units removed from transmission. An excellent working arrangement is provided by assembling the transmission to Holding Fixture J-8763. See Figure 74-102.
3. The transmission contains parts which are ground and highly polished, therefore, parts should be kept separated to avoid nicking and burring surfaces.
4. When disassembling transmission carefully inspect all gaskets at times of removal. The imprint of parts on both sides of an old gasket will show whether a good seal was obtained. A poor imprint indicates a possible source of oil leakage due to gasket condition, looseness of bolts, or uneven surfaces of parts.
5. None of the parts require forcing when disassembling or assembling transmission. Use a rawhide or plastic mallet to separate tight fitting cases - do not use a hard hammer.

74-10 REMOVAL OF OIL PAN, OIL STRAINER, VALVE BODY, LOW SERVO COVER AND PISTON ASSEMBLY

NOTE: Transmission need not be removed from the car to perform removal of the oil pan, oil strainer and valve body.

a. Removal of Oil Pan

1. If Transmission has been removed from car, assemble in Fixture J-8763. See Figure 74-102.

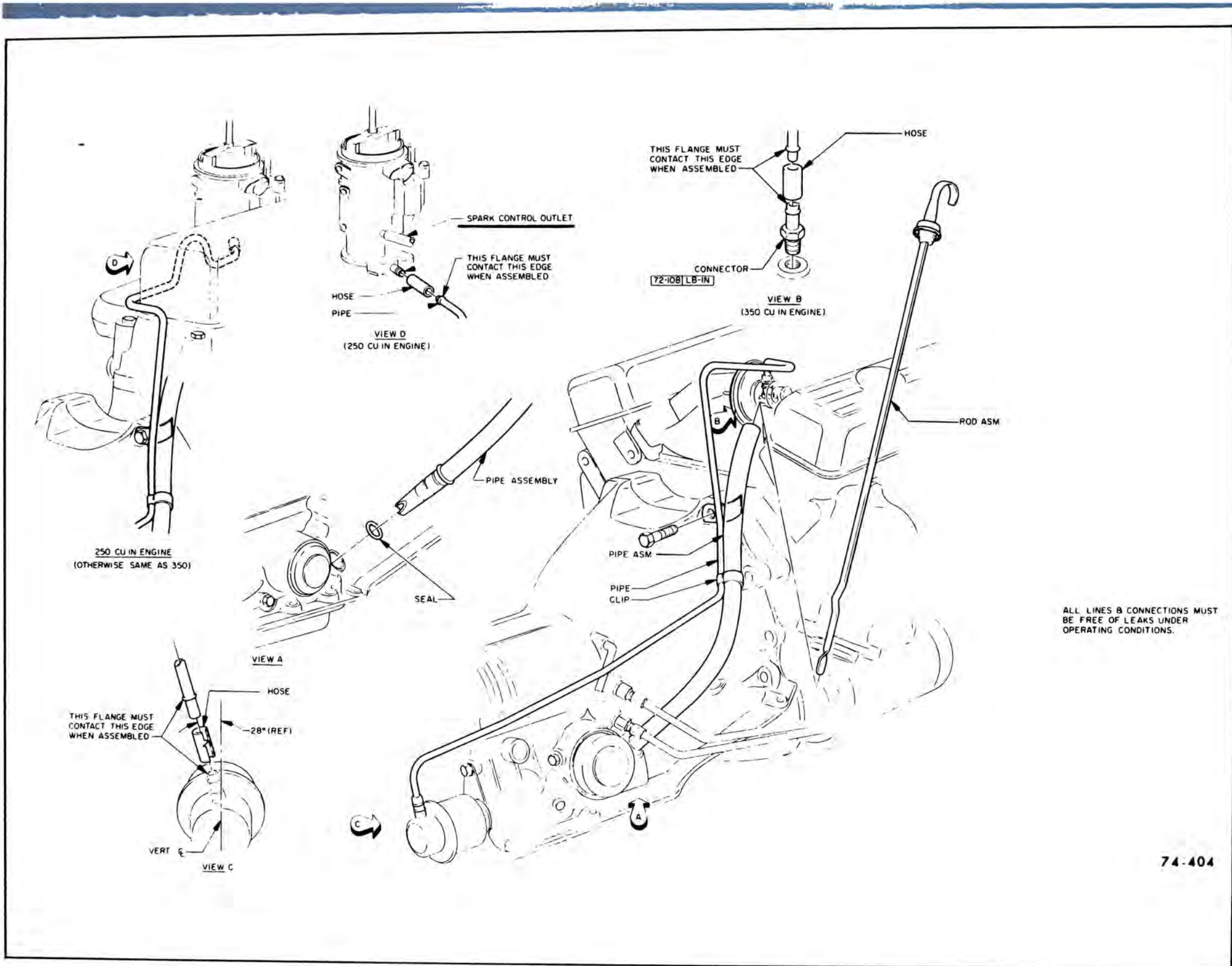

Figure 74-100—Vacuum Line and Oil Filler Pipe

74-404

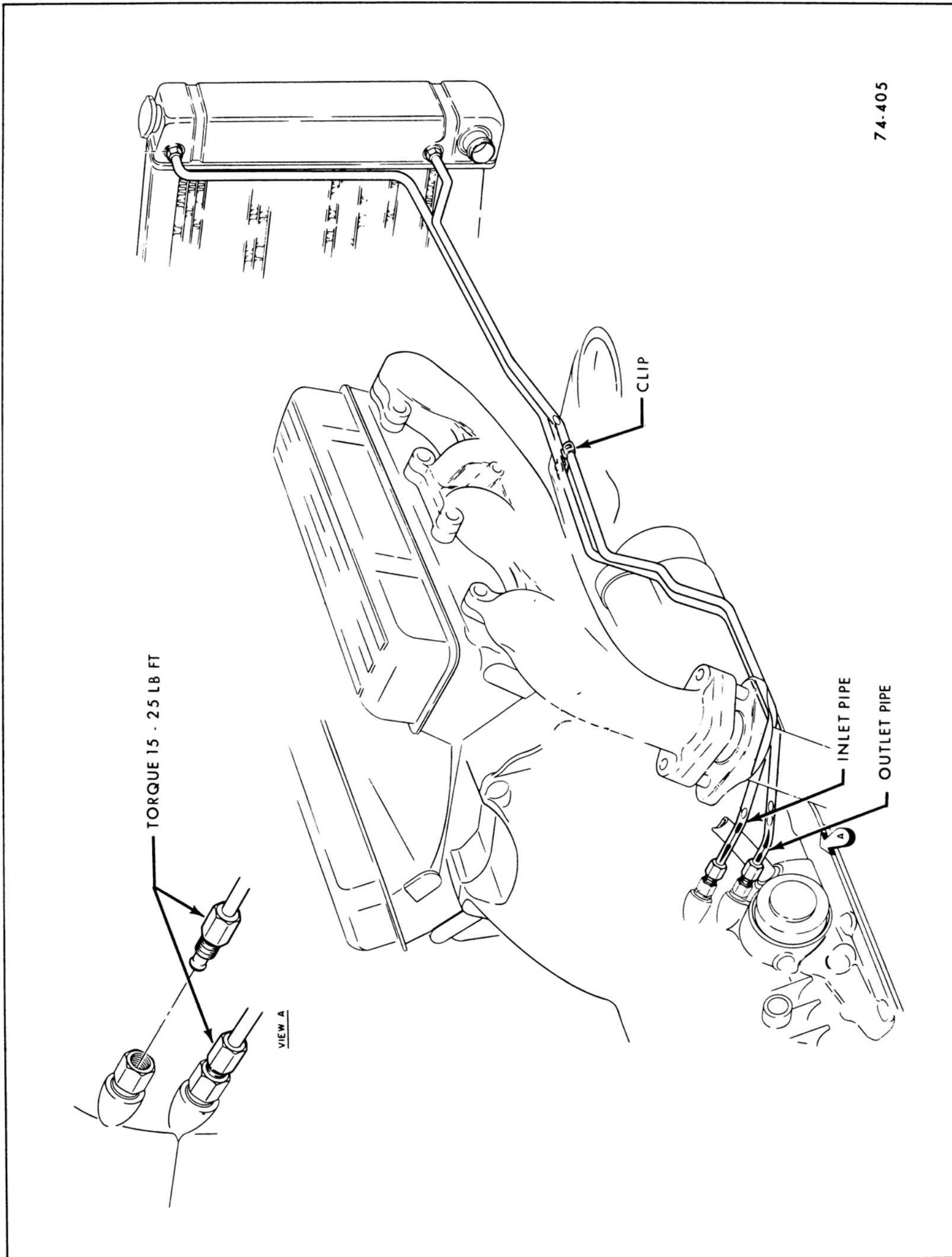

Figure 74-101—Oil Cooler Lines

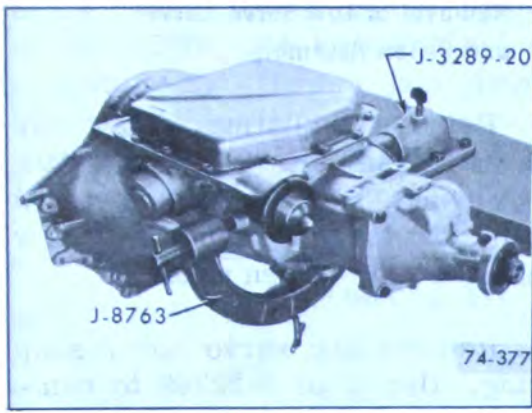

Figure 74-102

2. With transmission in horizontal position remove converter holding Tool J-21366. Remove converter.

3. Remove fourteen (14) oil pan attaching bolts.

4. Remove oil pan and gasket from transmission.

b. Removal of Oil Strainer

1. Remove oil strainer assembly. See Figure 74-103.

2. Remove oil strainer to case "O" ring and discard. See Figure 74-104.

c. Removal of Valve Body

1. Disconnect detent solenoid wire from case connector. See Figure 74-105.



Figure 74-104

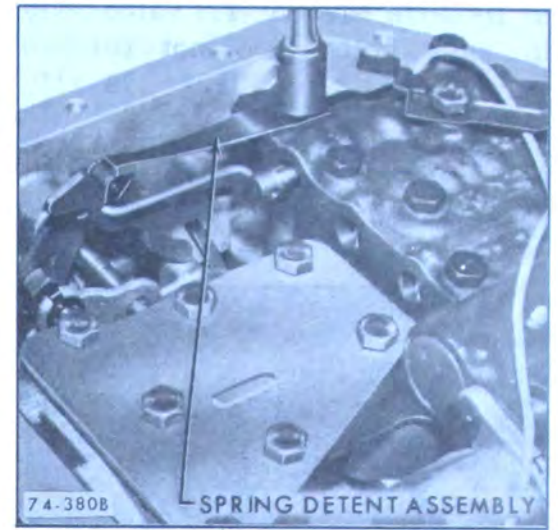

Figure 74-107



Figure 74-105



Figure 74-108

2. If necessary remove case connector from case. Inspect connector "O" ring. If nicked, torn or worn replace. See Figure 74-106.

3. Remove spring detent assembly from valve body. See Figure 74-107.

4. Remove oil channel support plate. See Figure 74-108.

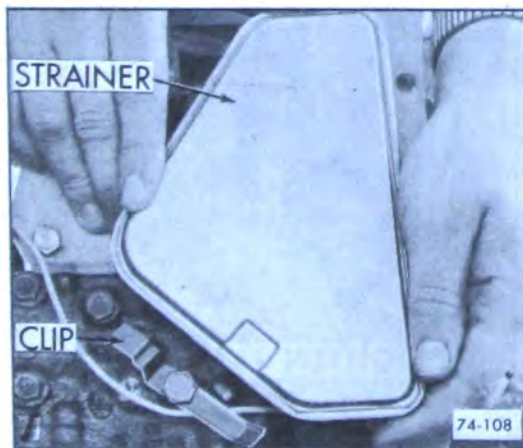

Figure 74-103



Figure 74-106

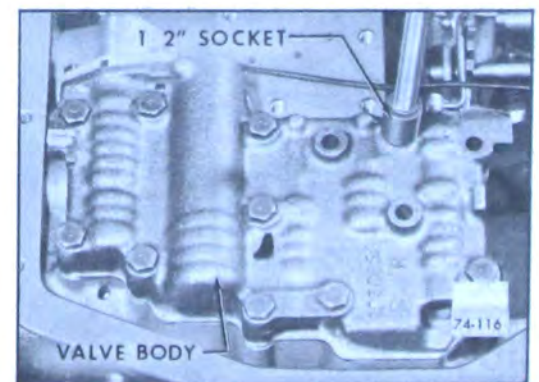

Figure 74-110

5. Remove eleven (11) valve body to case bolts. Do not remove valve body. See Figure 74-110.

6. Remove manual control valve link from inner Park lock and range selector lever. See Figure 74-111.



Figure 74-111

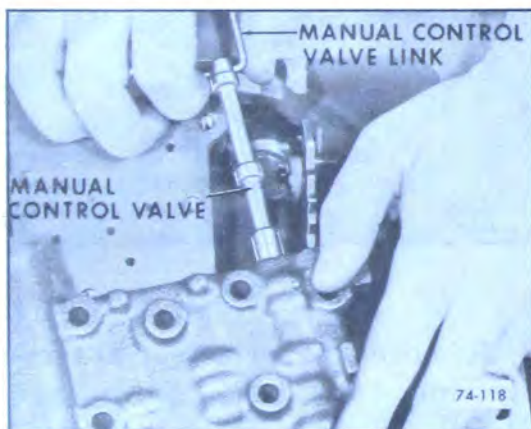

Figure 74-112

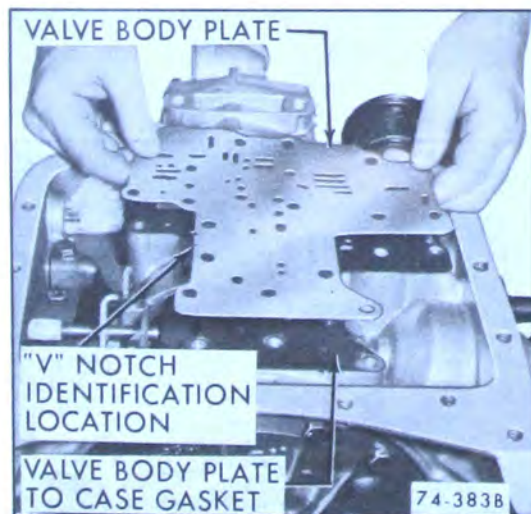

Figure 74-113

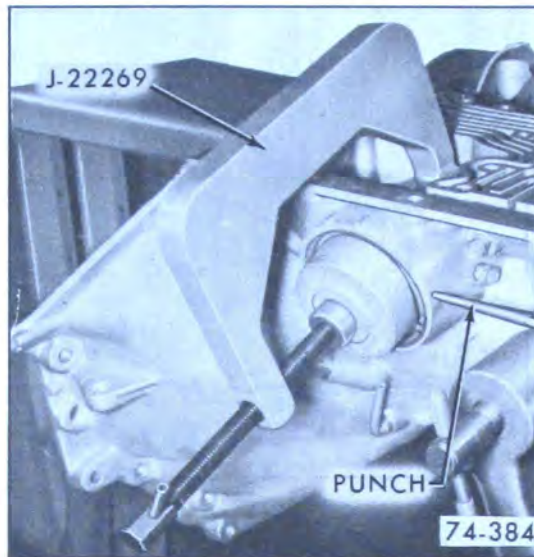

Figure 74-114



Figure 74-115

7. Remove manual control valve and link from valve body assembly. See Figure 74-112. Remove valve body.

8. Remove valve body plate and gasket. See Figure 74-113.



Figure 74-116

d. Removal of Low Servo Cover and Piston Assembly

1. Remove adjusting screw cap and loosen low band adjusting screw nut. Release tension on low band by turning adjusting screw using a 7/32" Allen wrench.

2. Remove low servo cover snap ring. Use Tool J-22269 to compress servo cover so snap ring can be removed with the aid of a punch and screwdriver. See Figure 74-114.

3. Remove Tool J-22269 and low servo cover from case.

IMPORTANT: If low servo cover is replaced, make certain all model information is stamped on new cover.

4. Inspect low servo cover oil seal. If nicked, torn or worn discard. See Figure 74-115.

5. Remove low servo piston assembly from case. See Figure 74-116.

74-11 REMOVAL OF OIL PUMP, FORWARD CLUTCH, AND LOW BAND

a. Removal of Oil Pump

1. With transmission in vertical position, remove eight (8) pump attaching bolts with washer type



Figure 74-117

seals, then install Slide Hammers J-7004 into threaded holes in pump and tighten jam nuts. Using slide hammers, loosen pump from case. See Figure 74-117. Remove pump and gasket.

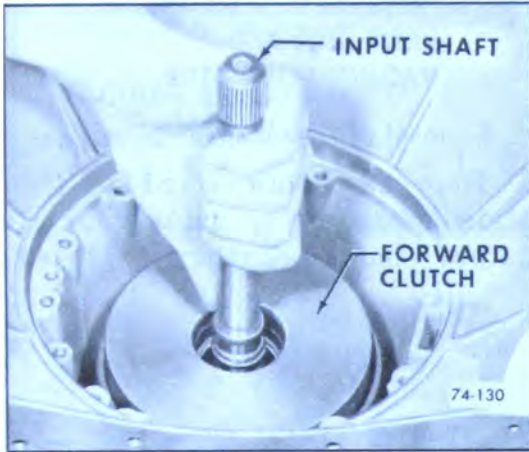

Figure 74-130



Figure 74-131

b. Removal of Forward Clutch

1. Remove input shaft from forward clutch. See Figure 74-130.
2. Examine the two (2) input shaft oil rings. If nicked or worn, re-

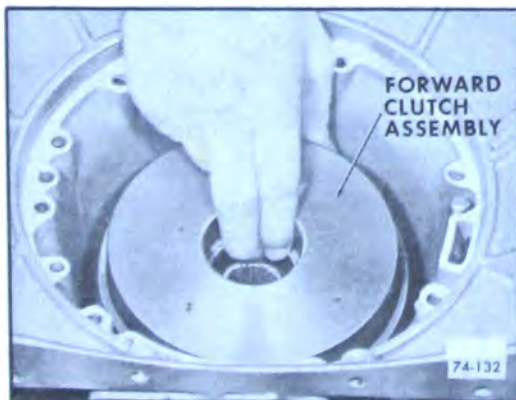

Figure 74-132

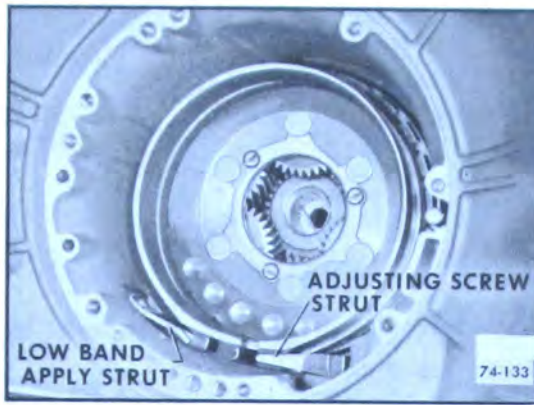

Figure 74-133

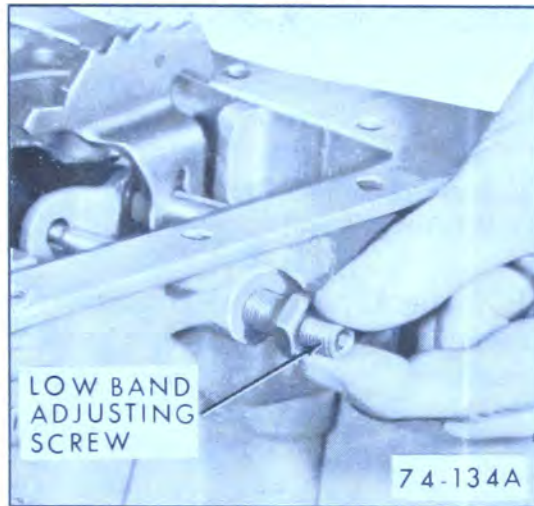

Figure 74-134

move and discard. See Figure 74-131.

3. Remove forward clutch assembly. See Figure 74-132.

c. Removal of Low Band

1. Remove low band, apply strut and adjusting screw from inside case. See Figure 74-133.
2. If replacement is required, re-



Figure 74-135

move low band adjusting screw. See Figure 74-134.

74-12 REMOVAL OF SPEEDOMETER DRIVEN GEAR, REAR BEARING RETAINER, RETAINER OIL SEAL RETAINER BUSHING, AND GOVERNOR

NOTE: Transmission need not be removed from car to perform the following operations.

a. Removal of Speedometer Driven Gear

1. With transmission in a horizontal position, remove speedometer driven gear sleeve retainer. See Figure 74-135.
2. Remove speedometer driven gear sleeve. See Figure 74-136.



Figure 74-136

b. Removal of Rear Bearing Retainer

1. Remove four (4) rear bearing retaining bolts. See figure 74-137. Remove rear bearing retainer from case.

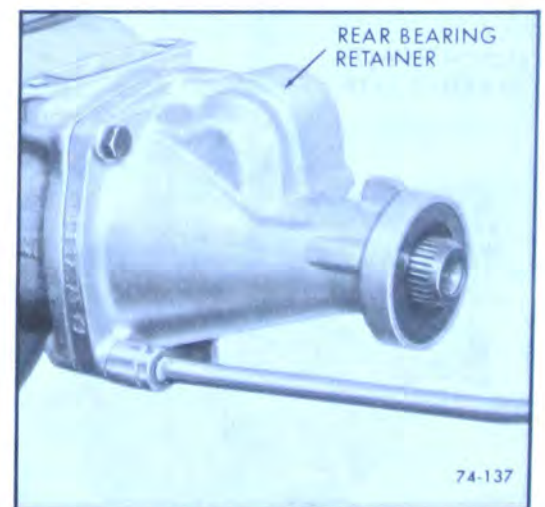

Figure 74-137

5. Remove eleven (11) valve body to case bolts. Do not remove valve body. See Figure 74-110.

6. Remove manual control valve link from inner Park lock and range selector lever. See Figure 74-111.



Figure 74-111

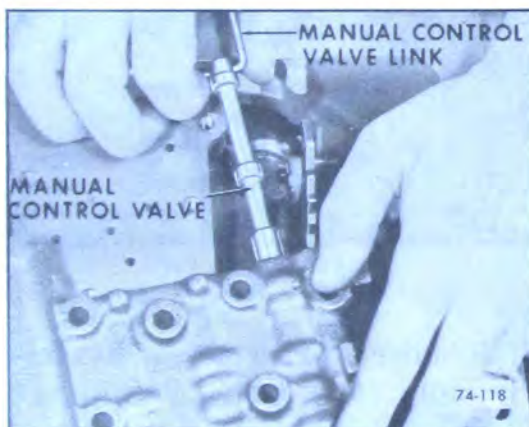

Figure 74-112

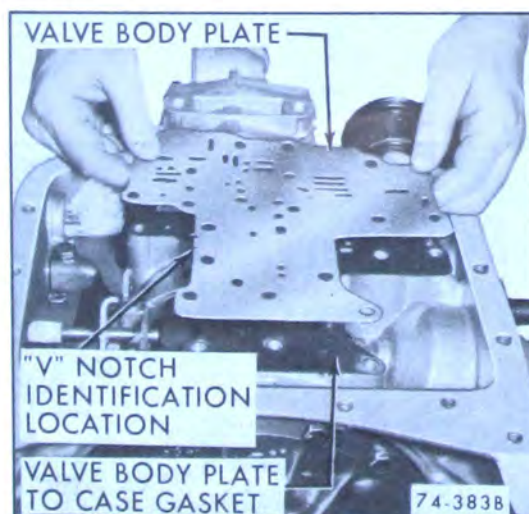

Figure 74-113

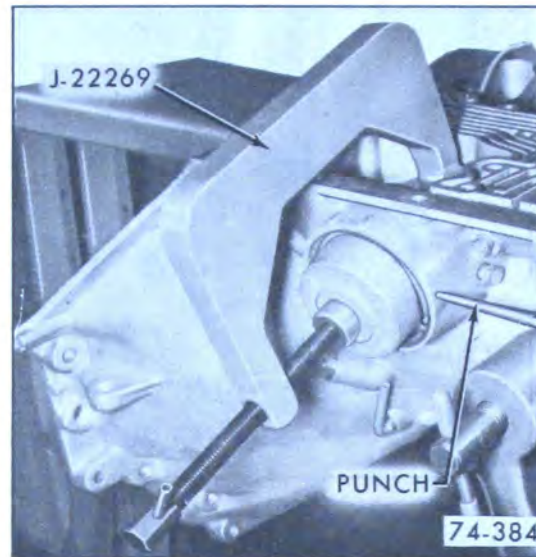

Figure 74-114



Figure 74-115

7. Remove manual control valve and link from valve body assembly. See Figure 74-112. Remove valve body.

8. Remove valve body plate and gasket. See Figure 74-113.



Figure 74-116

d. Removal of Low Servo Cover and Piston Assembly

1. Remove adjusting screw cap and loosen low band adjusting screw nut. Release tension on low band by turning adjusting screw using a 7/32" Allen wrench.

2. Remove low servo cover snap ring. Use Tool J-22269 to compress servo cover so snap ring can be removed with the aid of a punch and screwdriver. See Figure 74-114.

3. Remove Tool J-22269 and low servo cover from case.

IMPORTANT: If low servo cover is replaced, make certain all model information is stamped on new cover.

4. Inspect low servo cover oil seal. If nicked, torn or worn discard. See Figure 74-115.

5. Remove low servo piston assembly from case. See Figure 74-116.

74-11 REMOVAL OF OIL PUMP, FORWARD CLUTCH, AND LOW BAND

a. Removal of Oil Pump

1. With transmission in vertical position, remove eight (8) pump attaching bolts with washer type



Figure 74-117

seals, then install Slide Hammers J-7004 into threaded holes in pump and tighten jam nuts. Using slide hammers, loosen pump from case. See Figure 74-117. Remove pump and gasket.

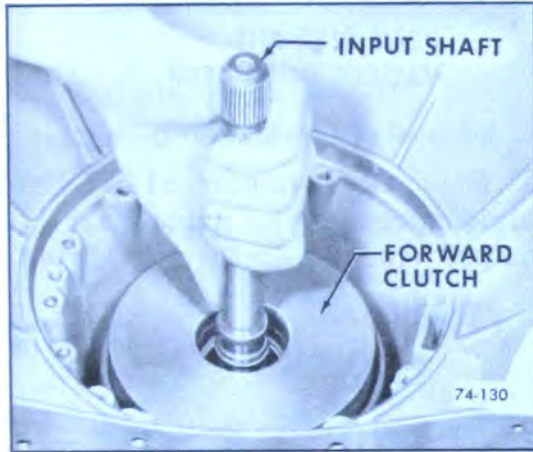

Figure 74-130



Figure 74-131

b. Removal of Forward Clutch

1. Remove input shaft from forward clutch. See Figure 74-130.
2. Examine the two (2) input shaft oil rings. If nicked or worn, re-

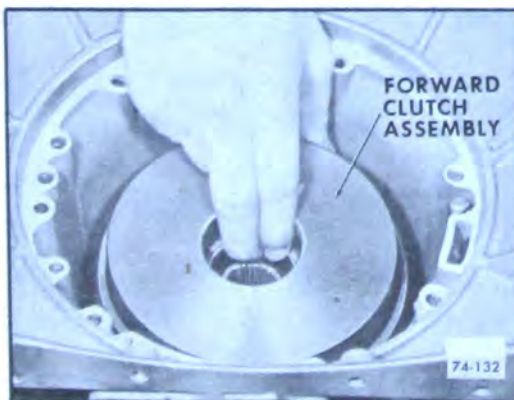

Figure 74-132

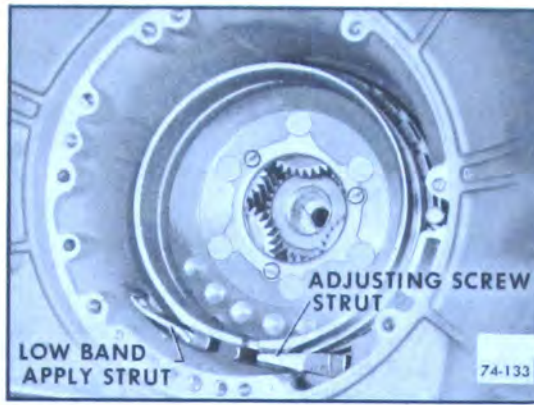

Figure 74-133

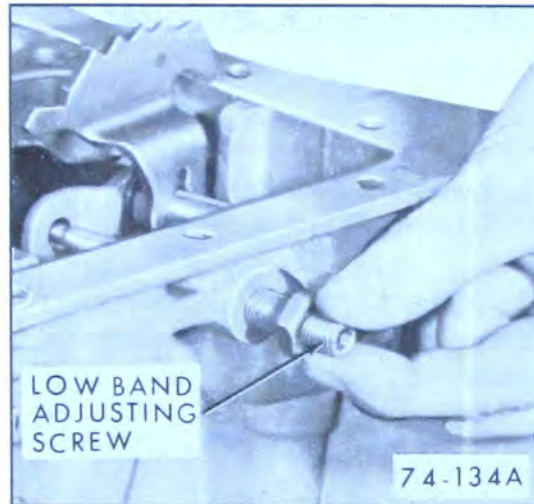

Figure 74-134

move and discard. See Figure 74-131.

3. Remove forward clutch assembly. See Figure 74-132.

c. Removal of Low Band

1. Remove low band, apply strut and adjusting screw from inside case. See Figure 74-133.
2. If replacement is required, re-



Figure 74-135

move low band adjusting screw. See Figure 74-134.

74-12 REMOVAL OF SPEEDOMETER DRIVEN GEAR, REAR BEARING RETAINER, RETAINER OIL SEAL, RETAINER BUSHING, AND GOVERNOR

NOTE: Transmission need not be removed from car to perform the following operations.

a. Removal of Speedometer Driven Gear

1. With transmission in a horizontal position, remove speedometer driven gear sleeve retainer. See Figure 74-135.
2. Remove speedometer driven gear sleeve. See Figure 74-136.



Figure 74-136

b. Removal of Rear Bearing Retainer

1. Remove four (4) rear bearing retaining bolts. See figure 74-137. Remove rear bearing retainer from case.

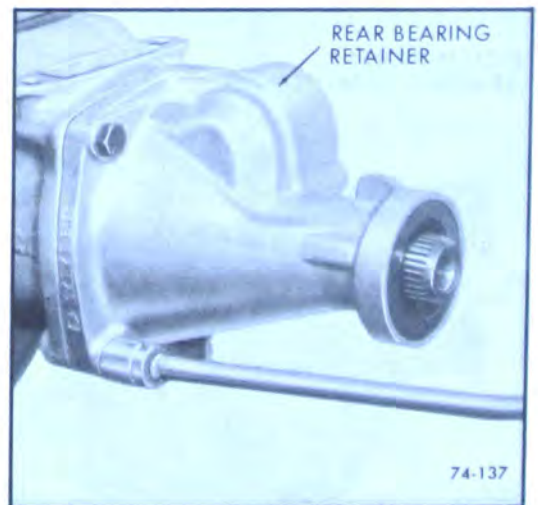

Figure 74-137

2. Remove rear bearing retainer oil seal. See Figure 74-138.



Figure 74-138

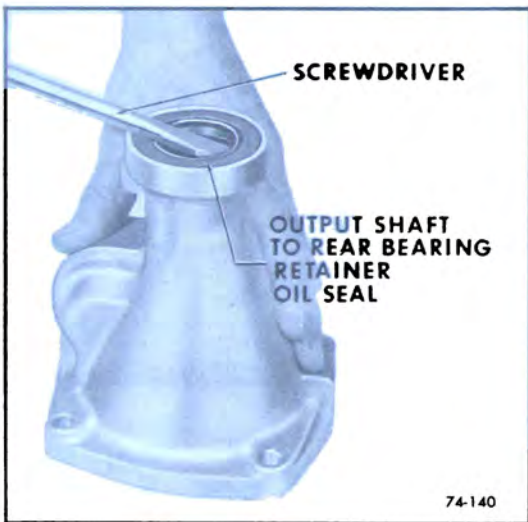

Figure 74-140



Figure 74-141

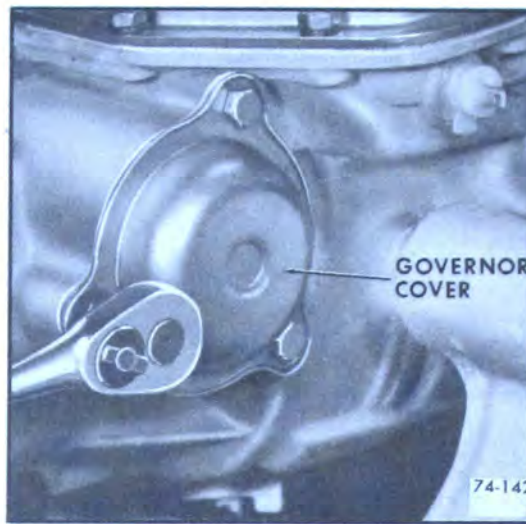

Figure 74-142

c. Removal of Rear Bearing Retainer Oil Seal

1. Inspect and if necessary remove output shaft to rear bearing retainer oil seal. See Figure 74-140.

d. Removal of Rear Bearing Retainer Bushing

1. Inspect and if necessary replace rear bearing retainer bushing. Place screwdriver in notch in rear bearing retainer, then tap screwdriver with hammer to collapse bushing. See Figure 74-141.

e. Removal of Governor

1. Remove three (3) attaching bolts retaining governor cover to

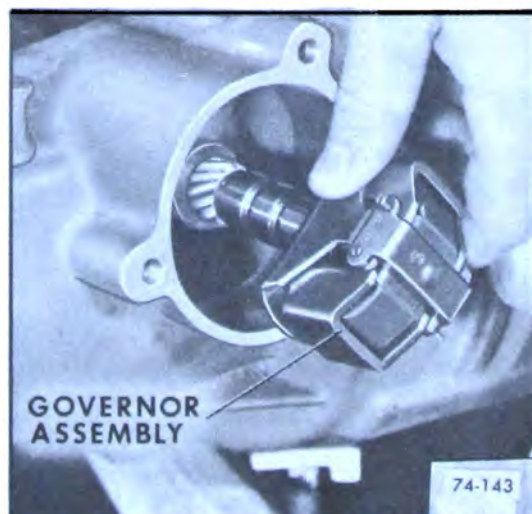

Figure 74-143

case. See figure 74-142. Remove cover and gasket.

2. With a twisting motion slide governor assembly out of its bore in case. See Figure 74-143.

74-13 REMOVAL OF SPEEDOMETER DRIVE GEAR AND VACUUM MODULATOR

a. Removal of Speedometer Drive Gear

1. Depress retainer clip, then slide speedometer drive gear off output shaft. See Figure 74-144.

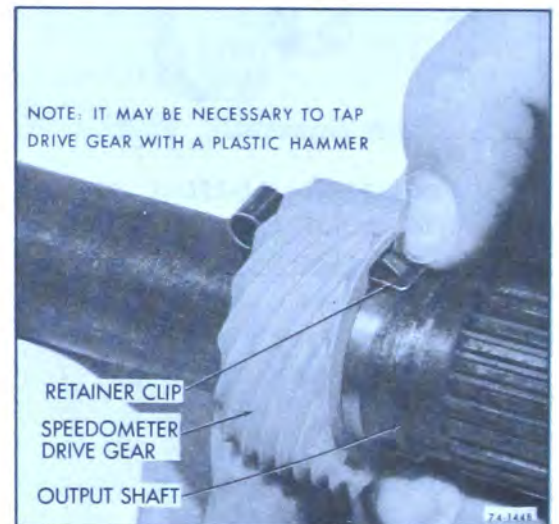

Figure 74-144

b. Removal of the Vacuum Modulator Assembly

1. Remove vacuum modulator retainer bolt and retainer. See Figure 74-145. Remove vacuum modulator and valve assembly.

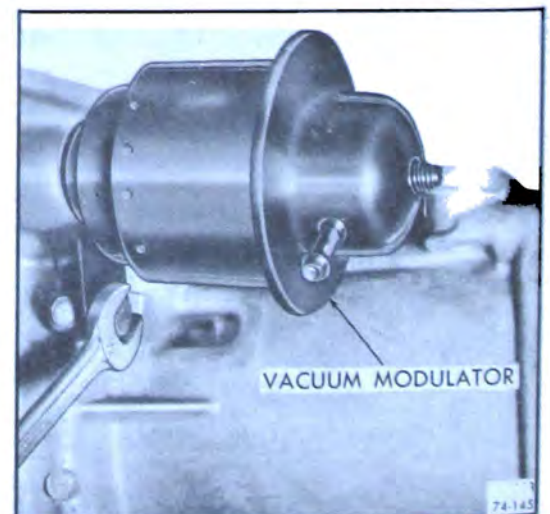

Figure 74-145

NOTE: Before modulator is diagnosed as a failed part refer to paragraph 74-34.

2. Inspect and if necessary remove vacuum modulator to case oil seal. See Figure 74-146.



Figure 74-146

74-14 REMOVAL OF PLANETARY GEAR SET, REVERSE CLUTCH AND PARKING LOCK MECHANISM

a. Removal of Planetary Gear Set

1. Remove planet carrier assembly from case, using extreme caution not to damage case bushing. See Figure 74-147.

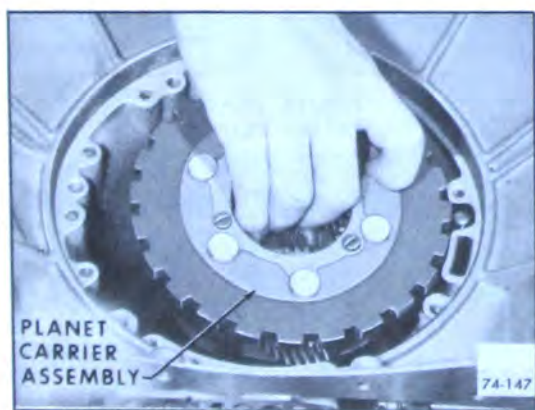

Figure 74-147

2. Remove reverse ring gear from case. See Figure 74-148.

3. Remove needle bearing and two (2) bearing races from rear of planet carrier. See Figure 74-150.

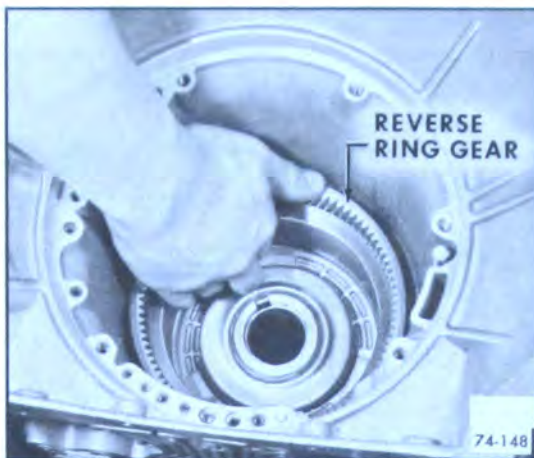

Figure 74-148

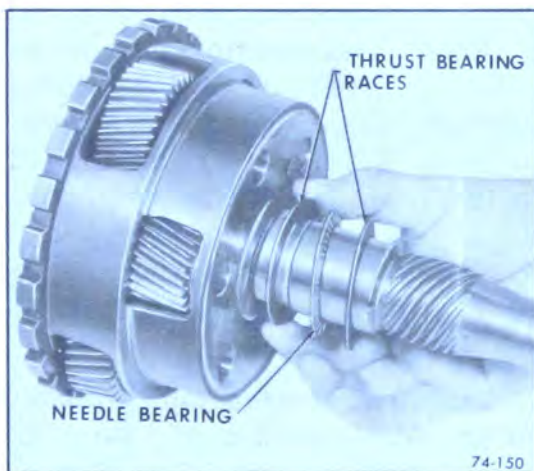

Figure 74-150

b. Removal of Reverse Clutch

1. Place transmission in vertical position and remove reverse clutch pack snap ring with screwdriver. See Figure 74-151.

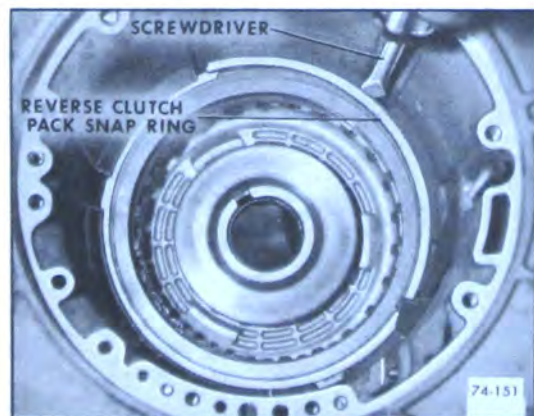

Figure 74-151

2. Lift reverse clutch pressure plate from transmission case. See Figure 74-152.



Figure 74-152

3. Remove reverse clutch pack from transmission case. See Figure 74-153.



Figure 74-153

4. To remove reverse piston, center Tool J-21420-1 on reverse clutch piston return seat. Install J-21420-2 over threaded shaft at rear of case. Tighten nut to compress piston seat; then remove snap ring with Pliers J-5586. See Figure 74-154.

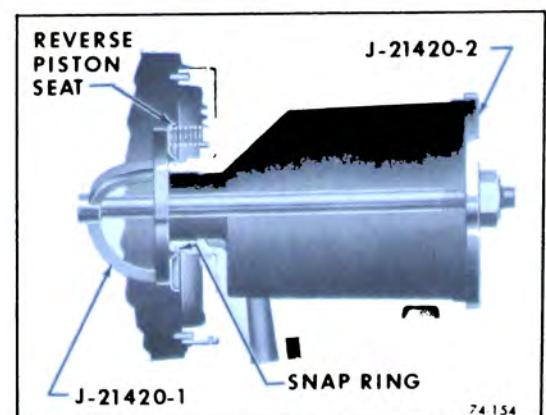

Figure 74-154

5. Loosen nut being careful that piston seat does not catch in snap ring groove in case. Remove tools. Remove piston seat and seventeen (17) piston return springs. See Figure 74-155.



Figure 74-155

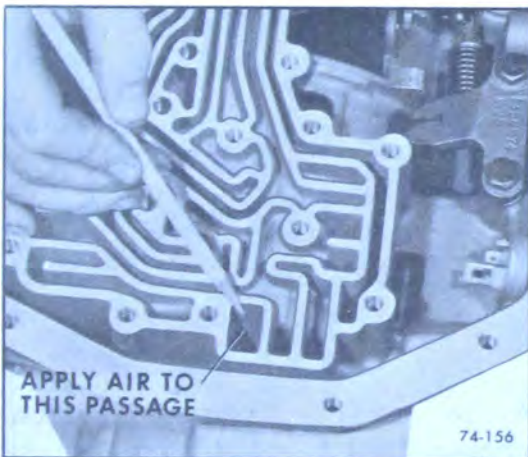

Figure 74-156



Figure 74-157

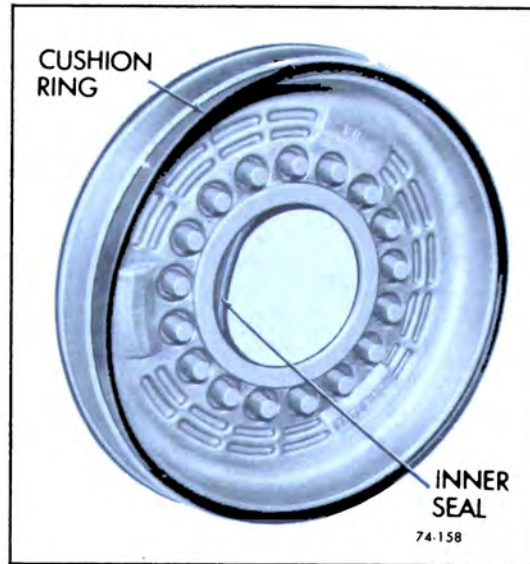

Figure 74-158

6. Place transmission in a horizontal position and remove reverse clutch piston with compressed air. As air is applied to the rear surface of the piston, it will pop out far enough so it can be removed. Insert air nozzle to rear of case as shown in figure 74-156.

7. Examine reverse clutch piston outer seal. If nicked, torn or worn, remove seal. See Figure 74-157.

8. Examine reverse clutch piston inner seal and cushion ring. If nicked torn or worn, remove. See Figure 74-158.

c. Removal of Range Selector Lever and Shaft, and Parking Lock Actuator

1. Remove two (2) parking lock

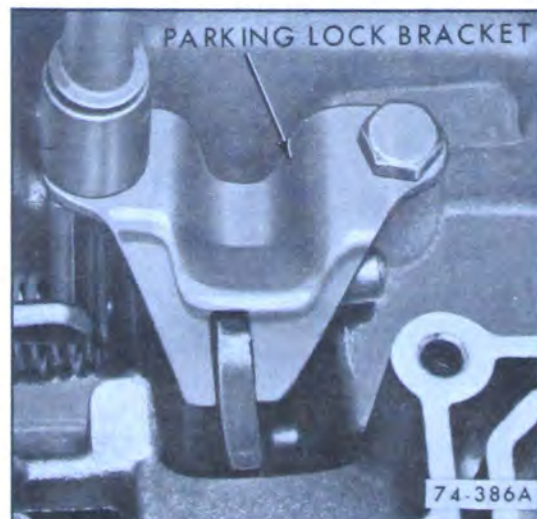

Figure 74-160

bracket bolts. See figure 74-160. Remove parking lock bracket.

2. Remove manual shaft retainer. See Figure 74-161.

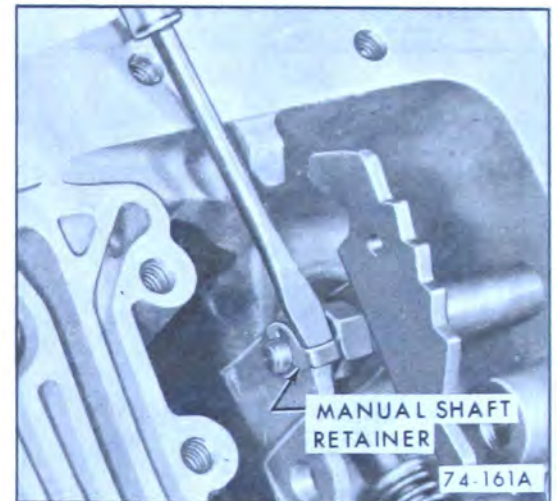

Figure 74-161

3. Fully loosen nut that retains manual shaft to inner park lock and range selector lever. See Figure 74-162.

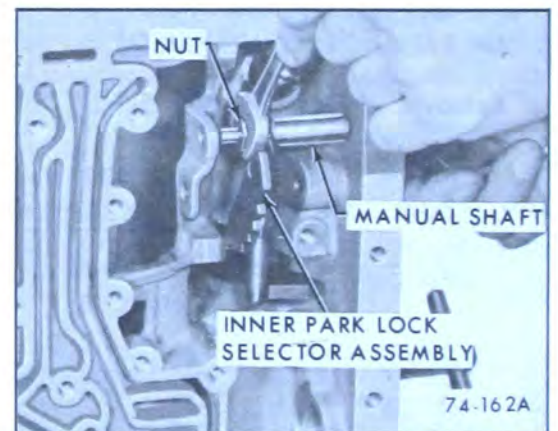

Figure 74-162

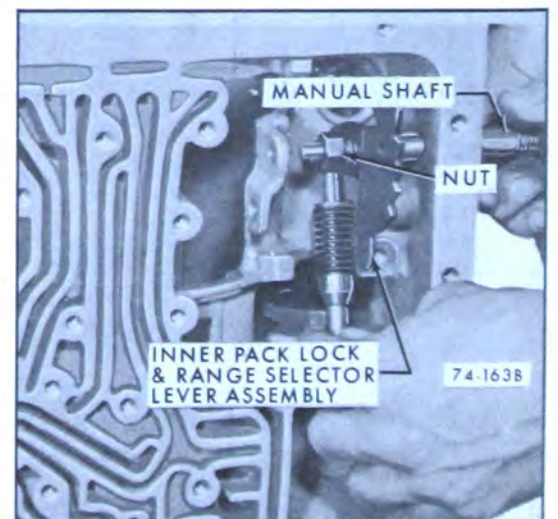

Figure 74-163

4. Slide manual shaft out of case. Remove nut, inner park lock and range selector lever assembly. See Figure 74-163.

5. Remove retaining ring which holds inner park lock and range selector lever to park lock actuator assembly. See Figure 74-164.

6. Slide parking pawl shaft out of parking pawl. Remove parking pawl and spring. See Figure 74-165.

7. Examine manual shaft oil seal. If nicked, torn or worn, replace seal. See Figure 74-166.



Figure 74-165

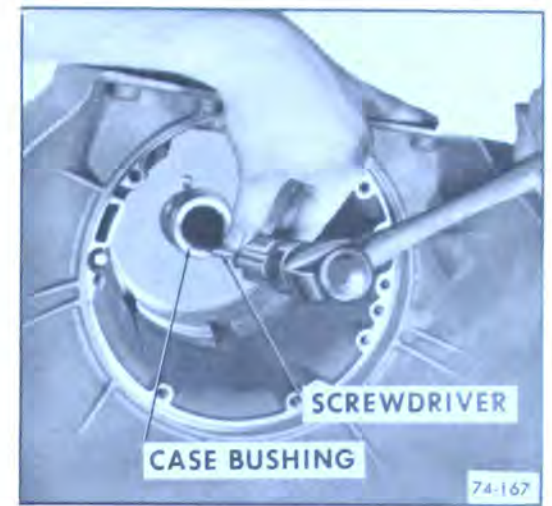

Figure 74-167



Figure 74-164



Figure 74-166



Figure 74-168

d. Removal and Installation of Case Bushing

1. Inspect case bushing for nicks, scoring or excessive wear. If damaged, remove as follows: Place screwdriver in notch in case, then tap screwdriver with hammer to collapse bushing. Remove bushing. See Figure 74-167.

2. Install case bushing, using Tool J-21424-2. Make certain split on bushing is opposite notch in case. See Figure 74-168.

74-15 VALVE BODY DISASSEMBLY, INSPECTION AND REASSEMBLY

a. Disassembly (Refer to Figure 74-169)

NOTE: Transmission need not be removed from car to perform the following operations.

1. Remove two (2) bolts attaching detent solenoid. Remove solenoid, solenoid gasket, spring and detent valve.

2. Depress shift control valve sleeve and remove retaining pin. Remove shift control valve sleeve, retainer, shift control valve, spring, and shift valve.

3. Depress modulator limit spring with Tool J-21547-1 and remove. Retaining pin will fall free. Remove spring and valve. See Figure 74-170.

NOTE: Modulator limit spring is under moderate force. Care should be exercised in removal.

4. Depress high speed down shift timing valve springs and remove

retaining pin, two springs, washer and valve.

b. Inspection

1. Thoroughly clean all valves and valve body in solvent. Inspect valves and valve body for evidence of wear or damage due to foreign material. Dry valve body and valves with clean air blast.

2. Test each valve in its bore. All valves must move freely of their own weight.

c. Reassembly of Valve Body (Refer to Figure 74-169)

1. Install high speed down shift timing valve, washer and two springs. Depress springs and install retaining pin.

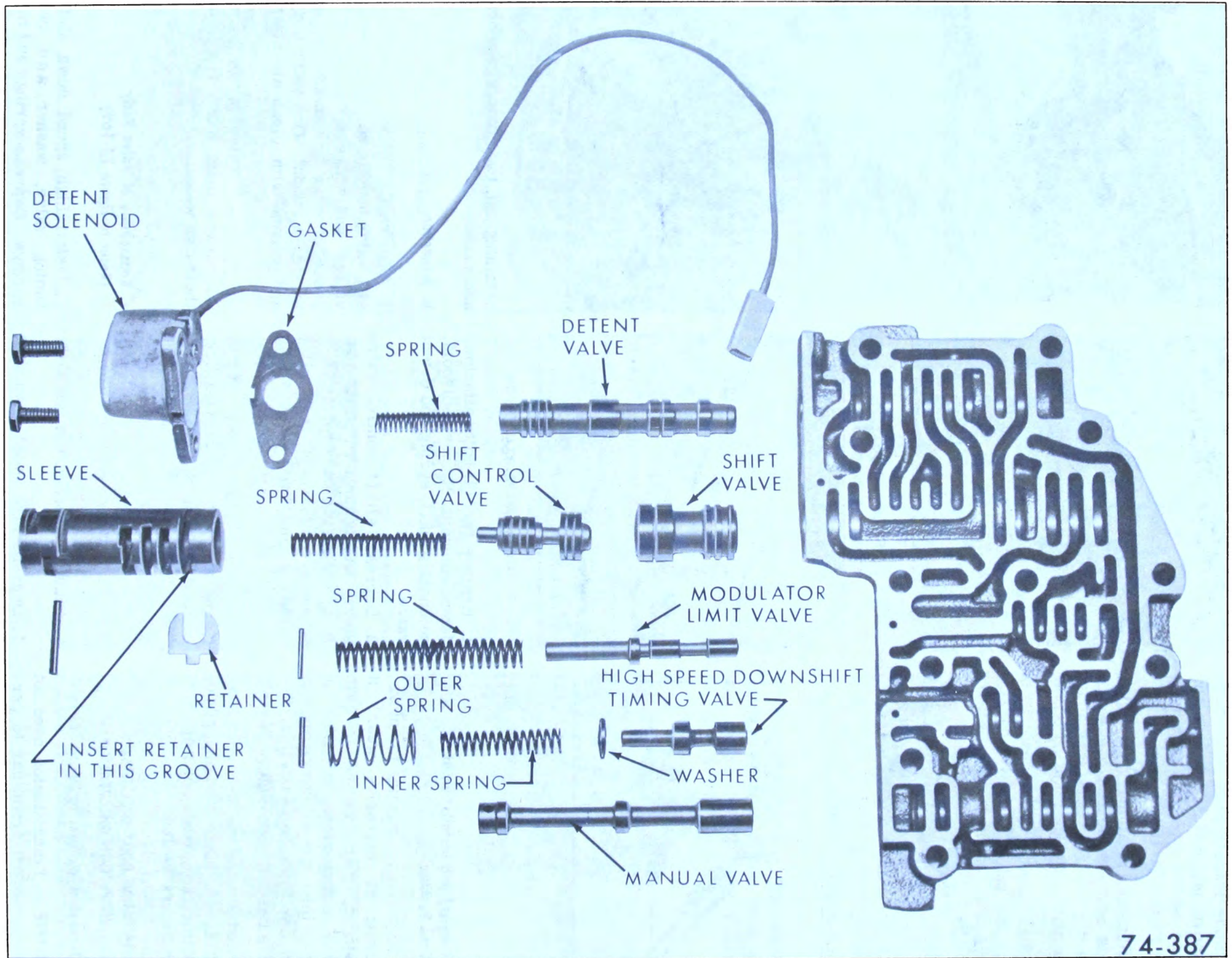

Figure 74-169



Figure 74-170

2. Install modulator limit valve, and spring into bore of valve body. With aid of Tool J-21547-1 compress spring and install retaining pin.

3. Install spring and shift control valve into sleeve. Depress spring and valve into sleeve and insert retainer in groove as shown. Install shift valve, sleeve assembly and retaining pin.

4. Install detent valve and spring. Install gasket to solenoid with notch facing bottom of valve body. Install solenoid to valve body.

74-16 LOW SERVO DISASSEMBLY AND REASSEMBLY

a. Disassembly

1. Remove secondary piston seal. See Figure 74-171.



Figure 74-171

2. Compress primary piston using J-22269 and remove retaining snap ring. Release J-22269. See Figure 74-172.

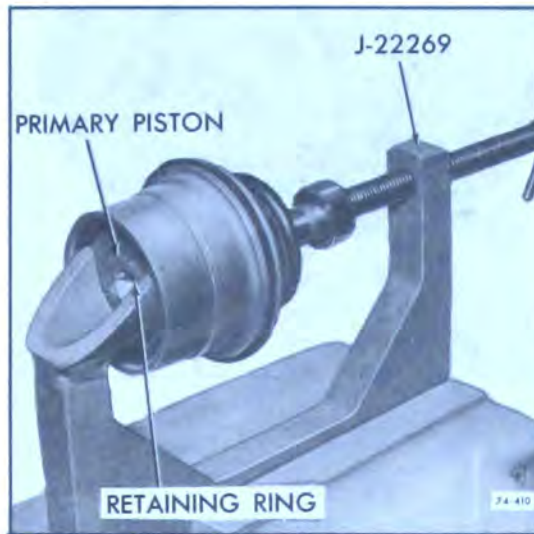

Figure 74-172

3. Remove primary piston, cushion spring, return spring, apply pin and washer from secondary piston assembly. See Figure 74-173.

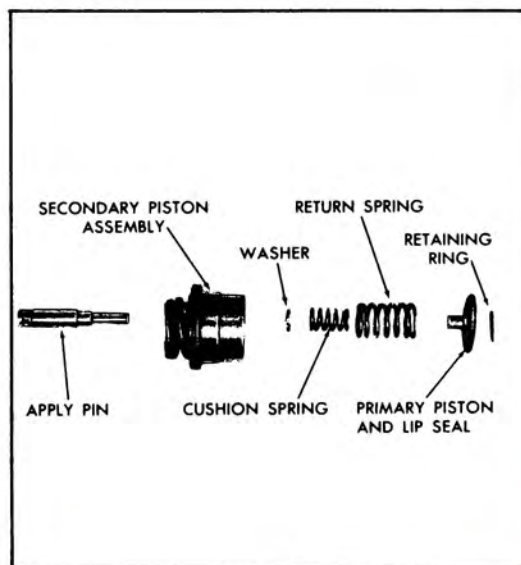

Figure 74-173

4. Inspect primary piston lip seal. If nicked, torn, or worn replace piston.

b. Reassembly

1. Install washer into secondary piston assembly. See Figure 74-174.

2. Install cushion and return

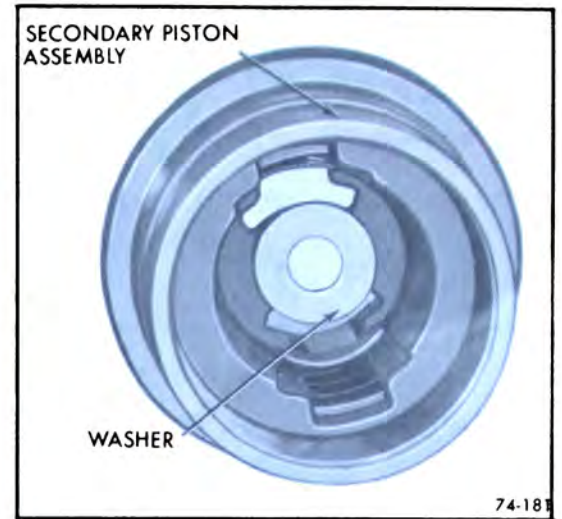

Figure 74-174

springs into secondary piston assembly. See Figure 74-175.

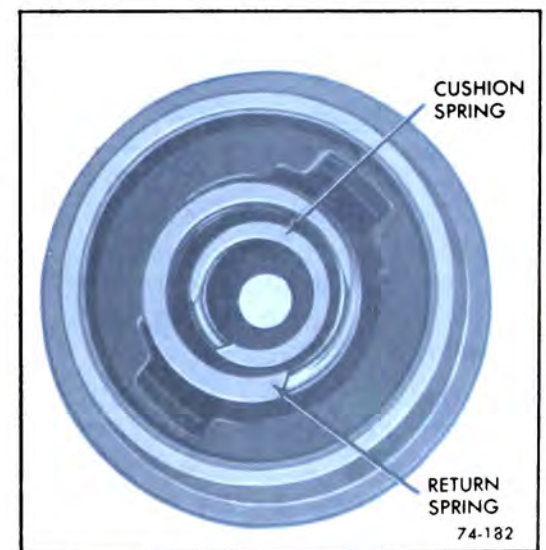

Figure 74-175

3. Install primary piston. Compress piston using J-22269. See Figure 74-176. Install new retaining snap ring.

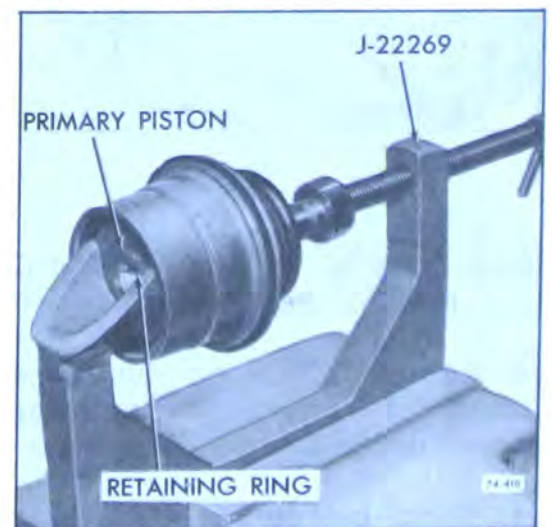

Figure 74-176

74-17 DISASSEMBLY, INSPECTION, AND REASSEMBLY OF THE OIL PUMP

a. Disassembly

1. Remove the two (2) hook type oil sealing rings from pump hub. See Figure 74-177.



Figure 74-177

2. Remove pump cover to forward clutch drum thrust washer. See Figure 74-178.



Figure 74-178

3. Remove oil pump to case seal and discard. See Figure 74-179.



Figure 74-179

6. Remove oil pump drive gear. See Figure 74-180.



Figure 74-180

7. Remove oil pump driven gear. See Figure 74-181.



Figure 74-181

5. Mark, but do not scar, gear faces so gears can be reassembled in same position.

8. Remove coast downshift timing valve, carefully check to make certain the spring returns the ball to its seat. See Figure 74-182.



Figure 74-182

9. Depress converter pressure relief valve spring. Remove retaining pin, spring, and relief ball. See Figure 74-183.

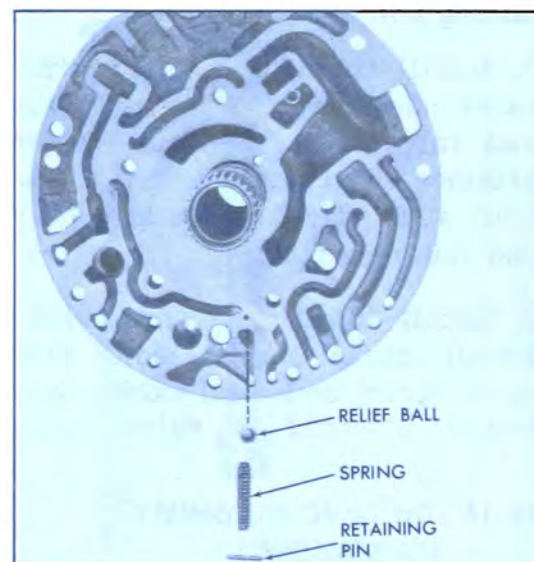

Figure 74-183

10. Compress boost valve sleeve with thumb and remove retaining snap ring. See Figure 74-184.

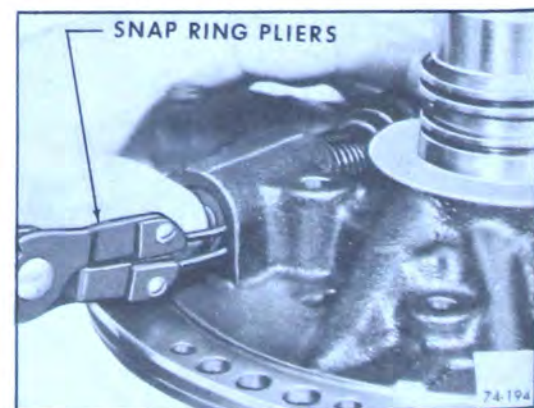

Figure 74-184

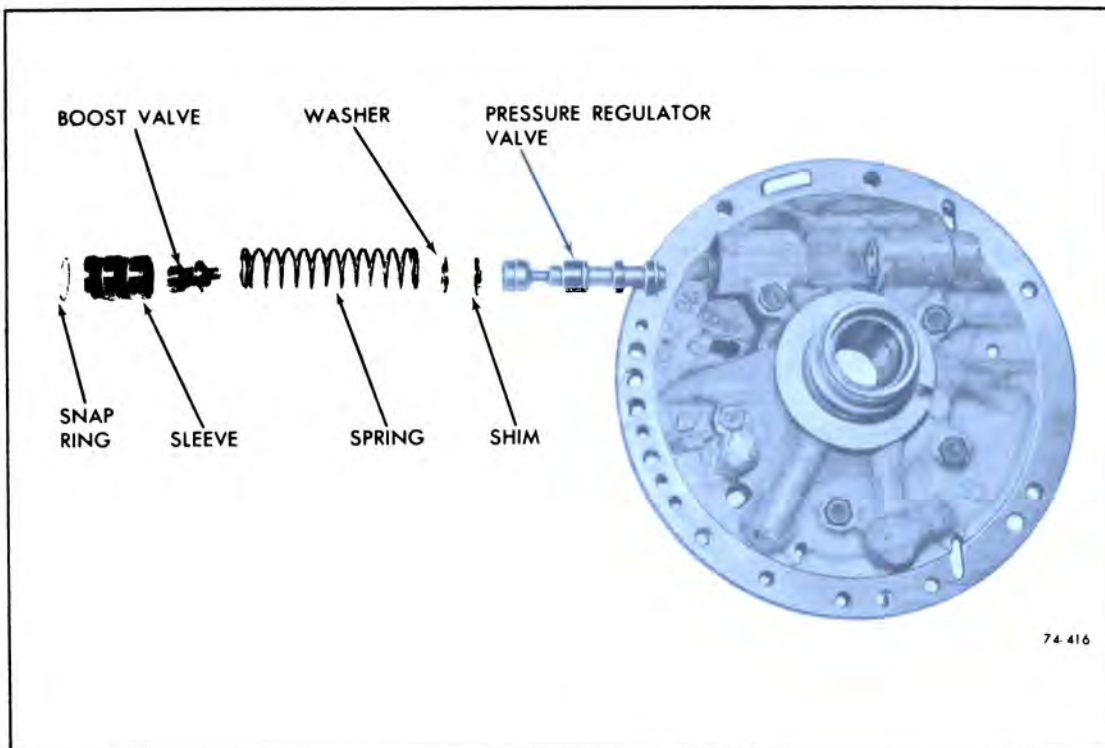

Figure 74-185

CAUTION: Reverse and modulator boost valve sleeve is under heavy spring force. Extreme care should be taken after retaining snap ring has been removed.

11. After retaining snap ring has been removed, remove boost valve sleeve, valve, spring, washer, and pressure regulator valve. See Figure 74-185.

12. Examine oil pump seal. If nicked, torn or worn remove seal as follows: Support oil pump body on wood blocks. Remove oil seal with a screwdriver and discard. See Figure 74-186.



Figure 74-186

13. Check oil pump bushing for

nicks, severe scoring or wear. If bushing replacement is necessary remove as follows: Support pump on wood blocks using Tool J-21465-17 and Drive Handle J-8092. Press bushing out of pump body. See Figure 74-187.



Figure 74-187

14. Check stator shaft bushing for nicks, severe scoring or wear. If bushing replacement is necessary remove as follows: Assemble Bushing Remover J-21424-7 to Extension J-21465-13. Assemble this assembly to Drive Handle J-8092. Grasp stator shaft with hand using other hand and assembled tools drive out bushing. See Figure 74-188.

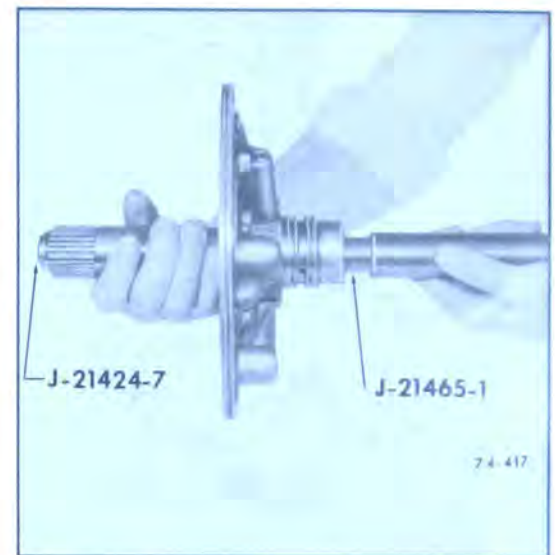

Figure 74-188

b. Inspection

1. Wash all parts in a cleaning solvent and blow out oil passages with compressed air.

2. Inspect pump gears for nicks or damage.

3. Inspect pump body for nicks or scoring.

4. With parts clean and dry, install pump gears, noting mark on gears for identification of the side that faces the pump cover. After gears have been installed, proceed as follows:

a. Install pump on converter hub. With dial indicator set, check end clearance. The clearance allowed is .0005/.0035. See figure 74-190.



Figure 74-190

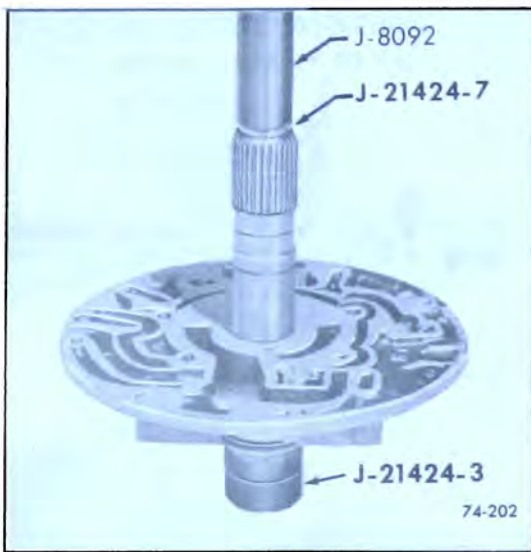

Figure 74-191

c. Reassembly

1. Using Tool J-21465-17 and J-8092 press new bushing into pump body from gear pocket face until it is flush to .010 below opposite face (front pump seal side).

2. Install stator shaft bushing as follows: Support pump assembly on J-21424-3 before installing bushing. Install bushing into the front end of stator shaft. Using Installer J-21424-7 and Drive Handle J-8092 tap bushing into shaft until it bottoms on shoulder in top of stator shaft. See Figure 74-191.

CAUTION: EXTREME CARE MUST BE TAKEN SO BUSHING IS NOT DRIVEN PAST SHOULDER.

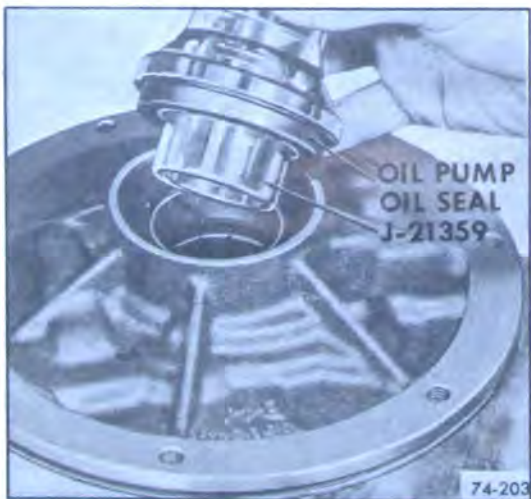

Figure 74-192

3. Using Installer J-21359 tap in new oil seal. See figure 74-192.
4. Install new oil pump to case seal. See Figure 74-193.



Figure 74-193

5. Assemble pressure regulator valve, shim, washer, spring, boost valve, and sleeve. See Figure 74-185.

CAUTION: When installing spring and shim make certain the same color spring and the proper number of shims are installed.

Color of Spring	Number of Shims
Maroon	None
Pink	One
White	Two

Actual number of shims may vary to meet production requirements.

6. Compress boost valve sleeve with thumb, then install retaining snap ring. See Figure 74-194.

7. Install converter pressure relief ball, spring and retaining pin. See Figure 74-195.

8. Install coast downshift timing valve. See Figure 74-196.

NOTE: Thrust washer and oil pump sealing rings will be installed during later operation.

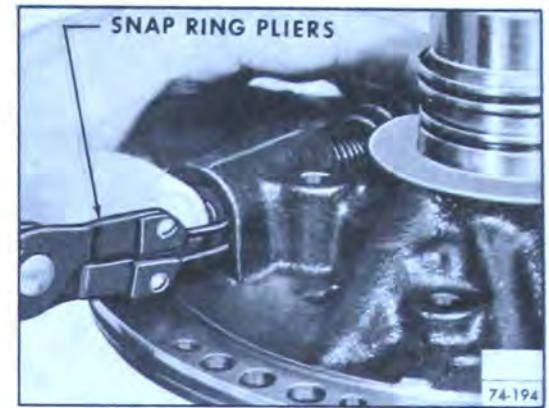

Figure 74-194

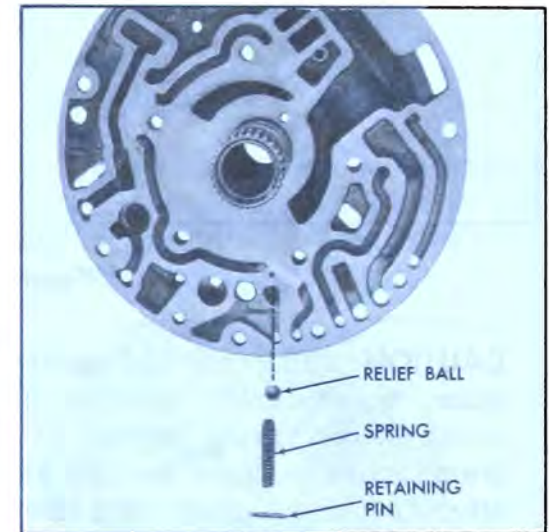

Figure 74-195

9. Install pump cover to pump body. Install retaining bolts finger tight. Place Tool J-21368 around pump to obtain proper alignment. See Figure 74-197. Tighten bolts in random sequence to 16-24 lb. ft. torque.

NOTE: The bolt next to the pressure regulator valve is a longer bolt.



Figure 74-196

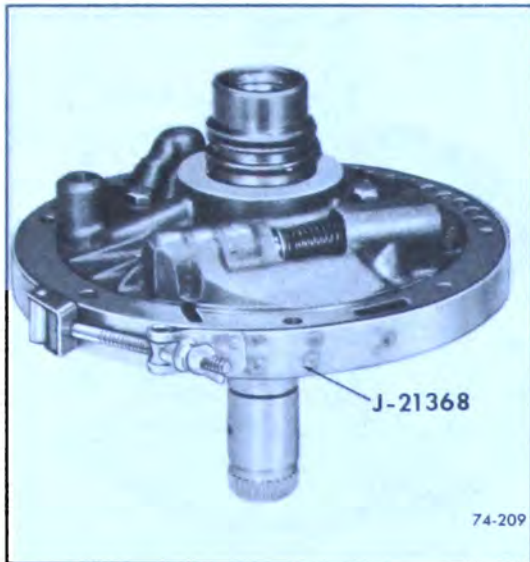

Figure 74-197

74-18 DISASSEMBLY, INSPECTION, AND REASSEMBLY OF FORWARD CLUTCH

a. Disassembly

1. Remove low sun gear and flange assembly retaining snap ring. See Figure 74-210.



Figure 74-210

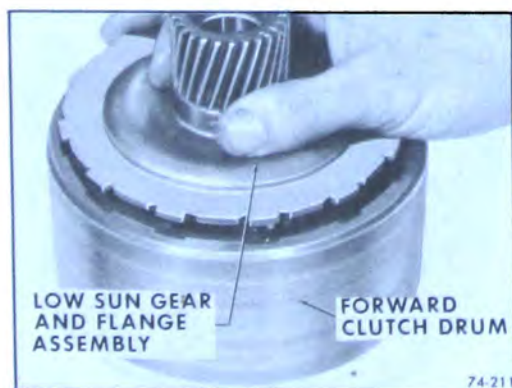

Figure 74-211

2. Remove low sun gear and flange assembly. See Figure 74-211.

3. Remove clutch hub rear thrust washer. See Figure 74-212.



Figure 74-212

spring retainer does not catch in snap ring groove.

NOTE: Place a piece of hard board between Tool J-2590-3 and surface of forward clutch.



Figure 74-214

4. Lift forward clutch hub from clutch pack. See Figure 74-213.



Figure 74-213

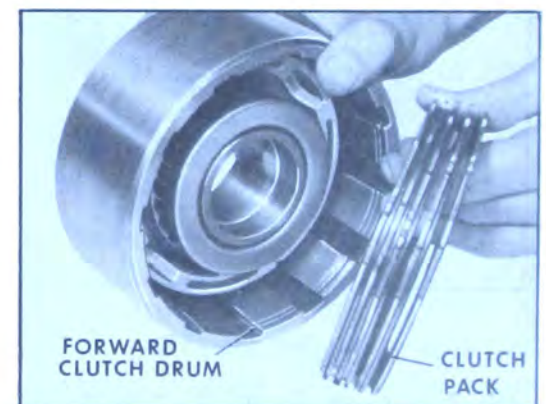

Figure 74-215

5. Remove clutch hub front thrust washer. See Figure 74-214.

6. Remove clutch pack from forward clutch drum. See Figure 74-215.

7. Using Tools J-2590-3, J-2590-5 and J-2590-12 compress spring retainer. Remove snap ring. See Figure 74-216. Then remove Tool J-2590 and component parts, being careful that

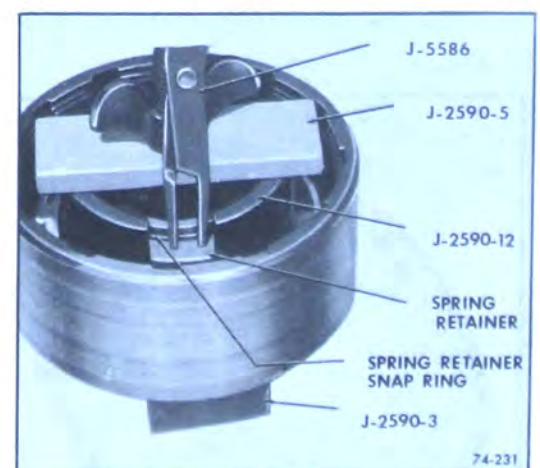

Figure 74-216

8. Lift off spring retainer and twenty-four (24) clutch springs. See Figure 74-217.



Figure 74-217

9. Lift up on forward clutch piston with a twisting motion and remove. See Figure 74-218.

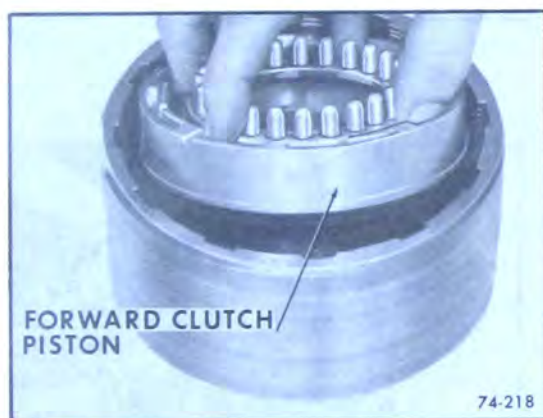

Figure 74-218

10. Examine forward clutch piston outer seal. If nicked, torn or worn, remove. See Figure 74-220.

NOTE: If cushion ring is damaged the entire piston must be replaced.



Figure 74-220

11. Examine forward clutch piston inner seal. If nicked, torn or worn, remove seal. See Figure 74-221.

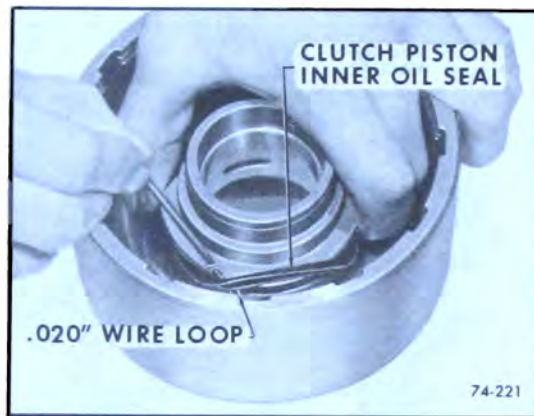

Figure 74-221

12. Check forward clutch drum bushing for nicks, severe scoring or wear. If bushing replacement is necessary proceed as follows: Using Tool J-21424-5, press damaged bushing out of forward clutch drum. See Figure 74-222.



Figure 74-222

13. Check low sun gear and flange assembly bushing for nicks, severe scoring, or wear. If bushing replacement is necessary proceed as follows: Support low sun gear assembly on press plate using Tool J-21424-4 and Drive Handle J-8092 press out bushing. See Figure 74-223.

b. Inspection

1. Wash all parts in a suitable



Figure 74-223

cleaning solvent. Use compressed air to dry.

2. Check steel ball in forward clutch drum. Make certain it is free to move in hole and that orifice leading to front of clutch drum is open.

3. Check clutch lined plates and steel driven plates.

c. Reassembly

1. Install J-21424-5 in front of forward clutch drum. Using Drive Handle J-8092 press bushing into bore until Tool J-21424-5 bottoms on hub. See Figure 74-225.

2. Install Tool J-21424-4 into low sun gear. Using Drive Handle



Figure 74-225

J-8092 press bushing into low sun gear until bushing installer is flush with top of low sun gear. See Figure 74-226.

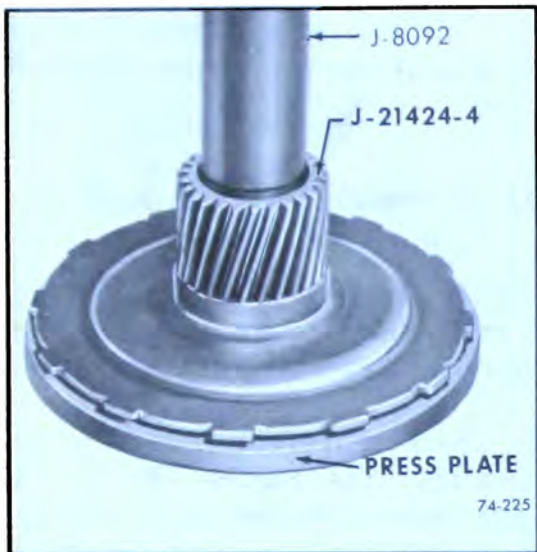

Figure 74-226

3. Lubricate with transmission oil and install new forward clutch piston inner seal with seal lip pointing downward. See Figure 74-227.



Figure 74-227



Figure 74-228

NOTE: Run hand around seal after it is installed to make certain seal is fully in groove.

4. Lubricate with transmission oil and install new forward clutch piston outer seal in clutch piston. Seal lip must point down. See Figure 74-228.

5. Install forward clutch piston into clutch drum using a loop of smooth wire to start lip of seal into bore. Piston should turn freely. See Figure 74-229.

NOTE: A satisfactory tool can be made by crimping a loop of .020" music wire in a short length of copper tubing.



Figure 74-229

6. Carefully reassemble return springs, retainer and snap ring. See Figure 74-230.



Figure 74-230

7. With spring retainer in place compress with Tools J-2590-3, J-2590-12 and J-2590-5 so spring retainer snap ring can be installed. Make sure retainer doesn't catch in snap ring groove when compressing springs. See Figure 74-231.

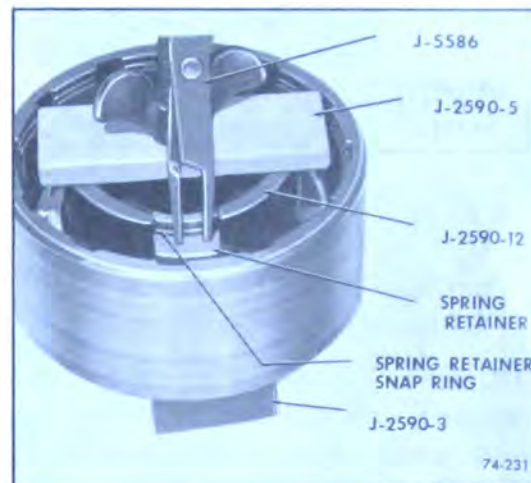

Figure 74-231

NOTE: Place a piece of hard board between Tool J-2590-3 and forward clutch drum.

8. Install clutch hub front thrust washer to clutch hub (retain with petroleum jelly) aligning tangs in clutch hub with grooves in thrust washer. Install clutch hub. See Figure 74-232.



Figure 74-232

9. Install steel driven plates and lined drive plates alternately, beginning with a steel driven plate. See Figure 74-233.

NOTE: L-6 models use 5 driven and 4 drive plates. V-8



Figure 74-233

models use 6 driven and 5 drive.

10. Install clutch hub rear thrust washer with its flange toward low sun gear and flange assembly. See Figure 74-234.



Figure 74-234

11. Install low sun gear and flange assembly. See Figure 74-235.

12. Install low sun gear and



Figure 74-235



Figure 74-236

flange assembly retaining ring. Position snap ring so gap is centered between slots in drum. See Figure 74-236.

74-19 DISASSEMBLY AND REASSEMBLY OF SPEEDOMETER DRIVEN GEAR

NOTE: Transmission need not be removed from the car to perform the following operations.

a. Disassembly

1. Remove speedometer driven gear. See Figure 74-237.
2. Examine speedometer driven gear oil seal. If nicked, torn or worn remove seal.
3. Examine speedometer driven gear shaft oil seal. If nicked, torn or worn remove seal.

b. Reassembly

1. Install speedometer driven

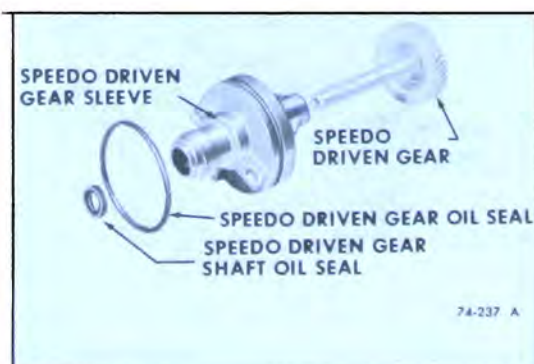

Figure 74-237

gear shaft oil seal. Install oil seal retaining ring.

2. Install speedometer driven gear oil seal. See Figure 74-237.
3. Install speedometer driven gear.

74-20 REMOVAL AND INSTALLATION OF GOVERNOR DRIVEN GEAR

Before any attempt is made to service the governor gear, the following check must be made.

1. Check governor feed port opening. See Figure 74-240. If less than .019" feed port opening is found, the complete governor assembly must be replaced.



Figure 74-240

a. Removal

1. Support governor sleeve on wood block as shown in Figure 74-241, remove roll pin with a 1/8" drill rod.

CAUTION: If wood block is placed under nylon gear, breakage of gear inside governor sleeve will result. Exercise extreme care not to damage machine surfaces of governor sleeve.

2. Remove driven gear. Remove any chips or burrs from inside governor sleeve.

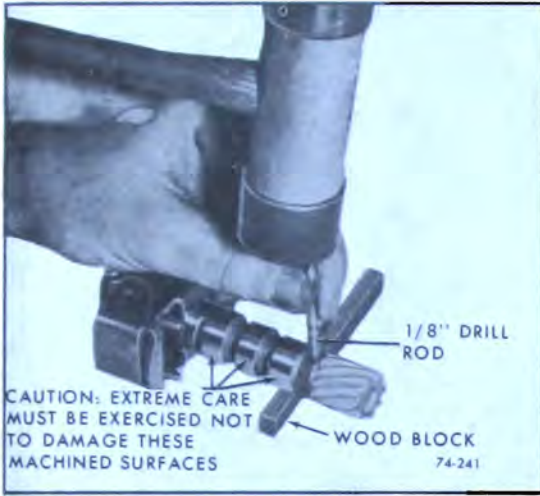

Figure 74-241



Figure 74-243

b. Installation

1. Install replacement gear by carefully pressing new gear into sleeve as follows:

a. Use press plate J-8853.

b. Place shim supplied in replacement gear kit between the second and third lands of governor sleeve. See Figure 74-242.

c. Make certain new gear is positioned squarely on sleeve and press gear into sleeve. Gear must be seated against sleeve. See Figure 74-242.

CAUTION: DO NOT SUPPORT OR HAMMER ON REAR OF GOVERNOR.

2. Through existing hole in governor sleeve, drill a 1/8" hole

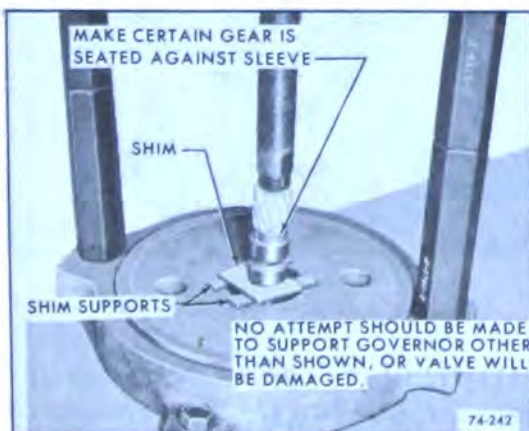

Figure 74-242

half-way through from each end. See Figure 74-243.

NOTE: It is important that the hole for roll pin be drilled straight as possible to insure proper retention and installation of roll pin and gear. This can be best accomplished by above method.

3. Support end of governor sleeve (not gear) on a wooden block. Install new roll pin; then using a small chisel, stake pin in place at both ends to prevent pin from becoming loose. See Figure 74-244.

4. Check for burrs on sleeve and if valve is free in its bore. Any



Figure 74-244

burrs that are left on governor sleeve will damage the case.

74-21 PLANET CARRIER DISASSEMBLY INSPECTION, AND REASSEMBLY

a. Disassembly

1. Remove three (3) planet pinion shaft lock plate screws and lock washers. See Figure 74-245.

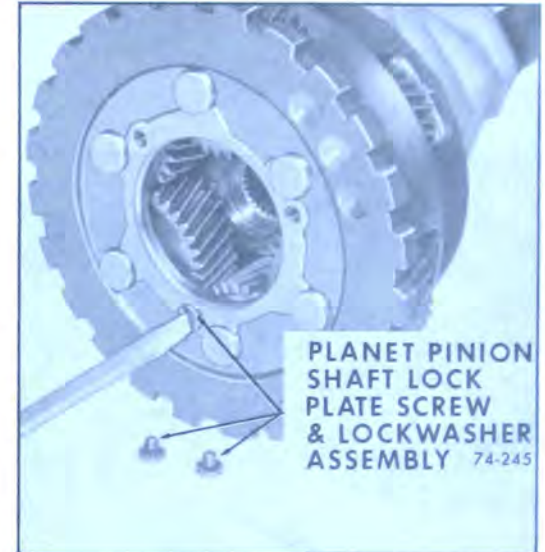

Figure 74-245

2. Rotate planet pinion lock plate and remove. See Figure 74-246.



Figure 74-246

3. Start with a soft planet pinion first. Insert Brass Drift into front of carrier. See Figure 74-247.

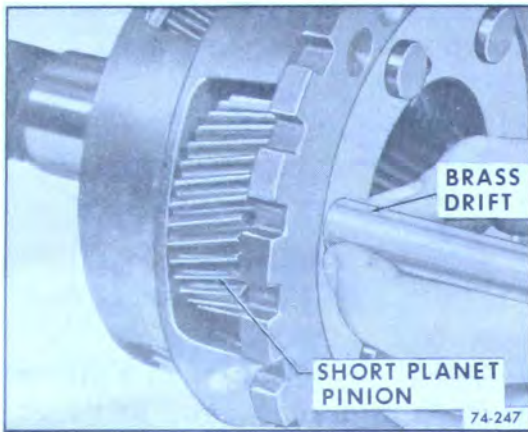

Figure 74-247

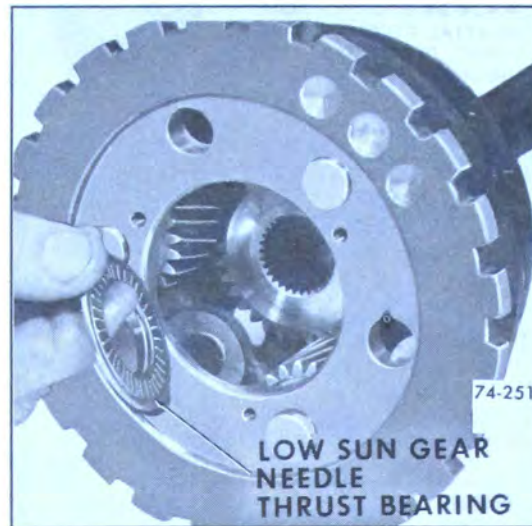

Figure 74-251

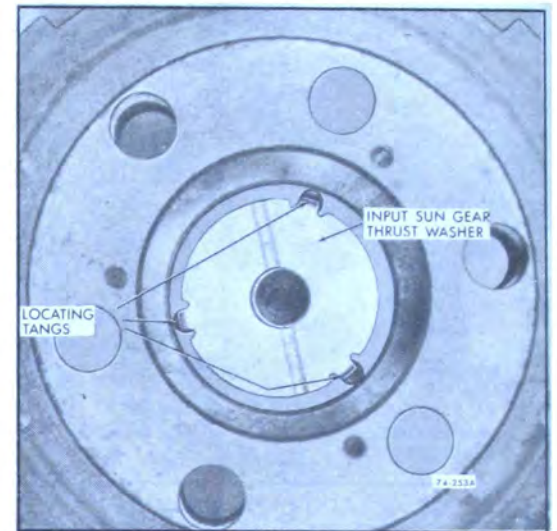

Figure 74-253

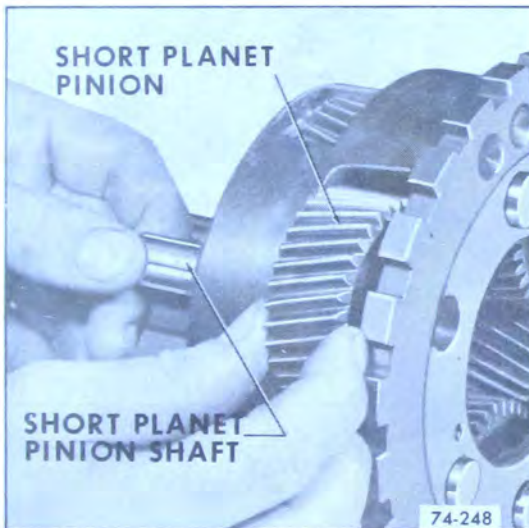

Figure 74-248

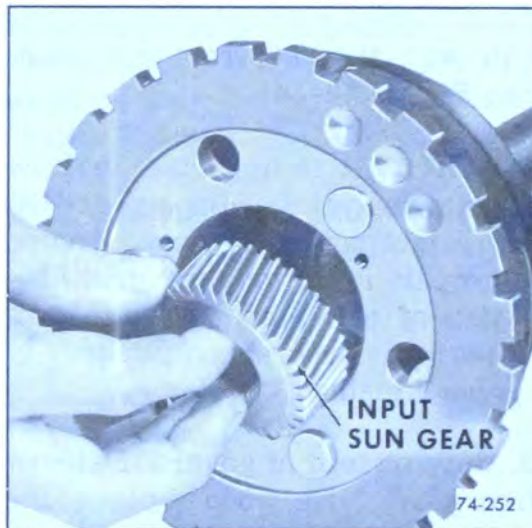

Figure 74-252

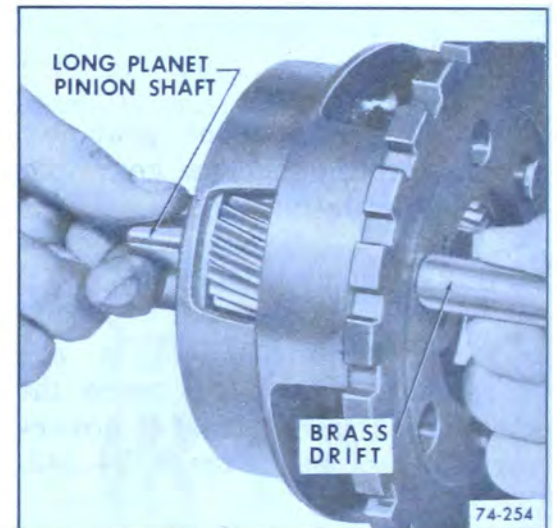

Figure 74-254

4. Remove pinion shaft and pinion gear from planet carrier. See Figure 74-248.

5. Remove needle bearings, and thrust washers (2) from the short

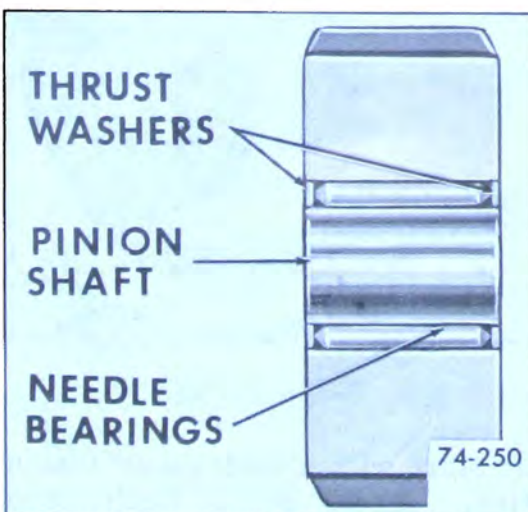

Figure 74-250

planet pinion gear. See Figure 74-250.

NOTE: Remove the other two (2) short planet pinion gears in same manner as described in Steps 4 and 5.

6. Remove low sun gear needle thrust bearing. See Figure 74-251.

7. Remove input sun gear. See Figure 74-252.

8. Remove input sun gear thrust washer. See Figure 74-253.

9. Insert Brass Drift through long planet pinion. Remove the long planet pinion shaft. See Figure 74-254.

10. Remove front planet pinion

thrust washer and long planet pinion gear. See Figure 74-255.

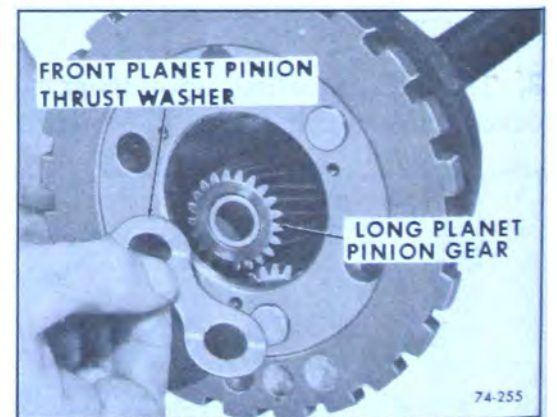

Figure 74-255

11. Remove needle bearings, spacer and two (2) thrust washers from the long planet pinion gear. See Figure 74-256.

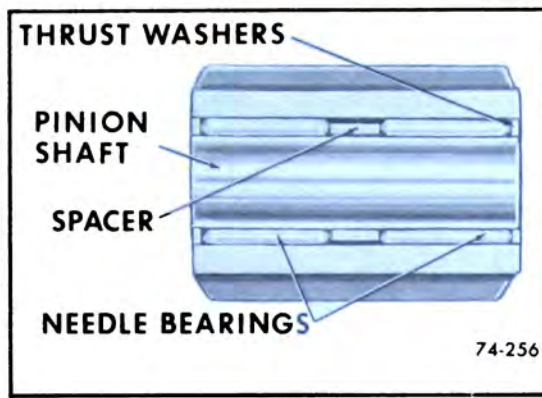

Figure 74-256

12. Remove rear planet pinion thrust washer. See Figure 74-257.



Figure 74-257

13. Check output shaft bushing for nicks, severe scoring or wear. If bushing replacement is necessary remove as follows: Install Bushing Remover J-9534 into bushing. Install Slide Hammer J-2619 into J-9534, using slide hammer re-



Figure 74-258

move bushing from planet carrier. See Figure 74-258.

b. Inspection of Planet Carrier Parts

1. Wash all parts in a cleaning solvent. Air dry all parts.
2. Check the planet pinion gears and input sun gear tooth damage.
3. Check planet pinion thrust washers and input sun gear thrust washer.
4. Check planet pinion needle bearings. If bearings show excessive wear, all needle bearings must be replaced.
5. Check the planet pinion shafts closely, if worn replace.

c. Reassembly

1. Using Tool J-21424-3 and J-8092 press the new bushing in until J-21424-3 touches the machined surface of the planet carrier assembly. See Figure 74-260.
2. Start with the long planet pinion gears first. Install the long planet pinion rear thrust washer. Oil groove must be toward pinion gear. Retain thrust washer with petroleum jelly. See Figure 74-261.
3. Install front planet pinion thrust washer. Retain thrust washer to case with petroleum jelly. Oil grooves on the thrust washer must be toward the pinion

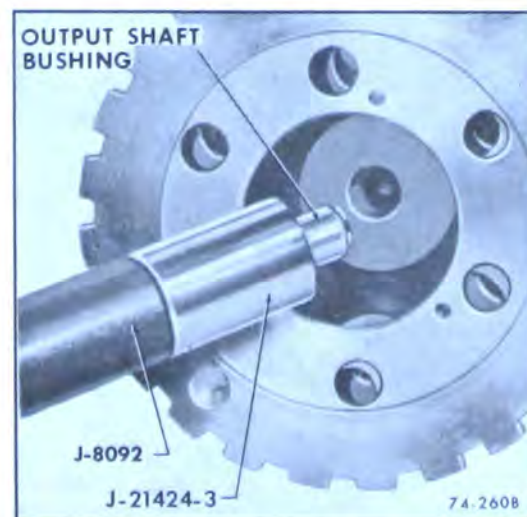

Figure 74-260

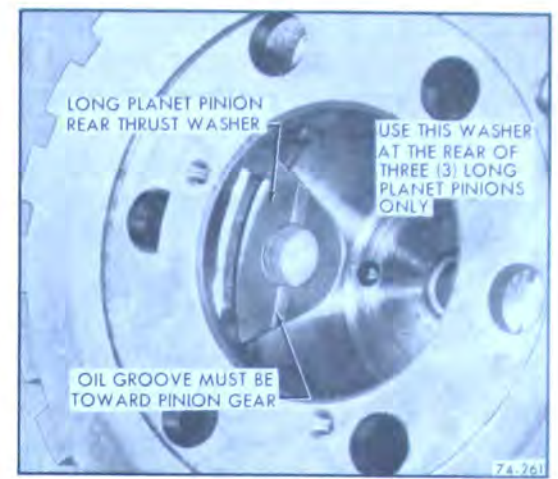

Figure 74-261

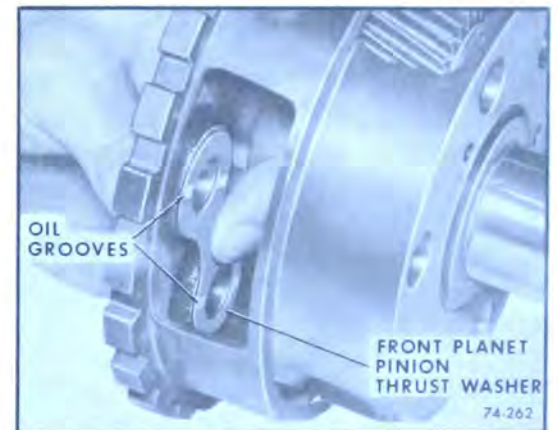

Figure 74-262

4. Coat inside pinion gear with petroleum jelly. Install Pinion Shaft into long planet pinion gear. Install twenty (20) needle bearings, spacer, twenty more needle rollers, and two (2) thrust washers. See Figure 74-263.

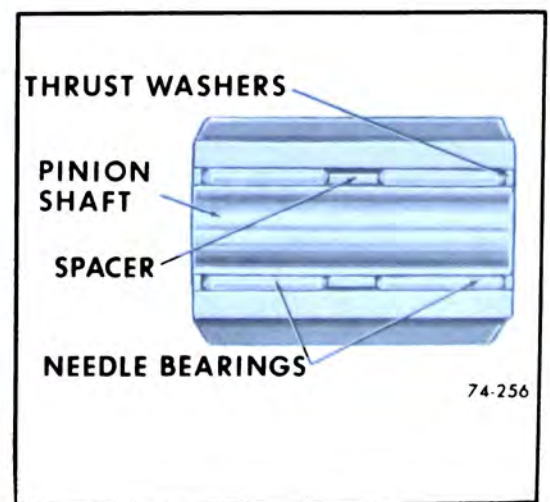

Figure 74-263

Carefully remove pinion shaft. With a twisting motion lock both sets of needle rollers in place. See Figure 74-264.

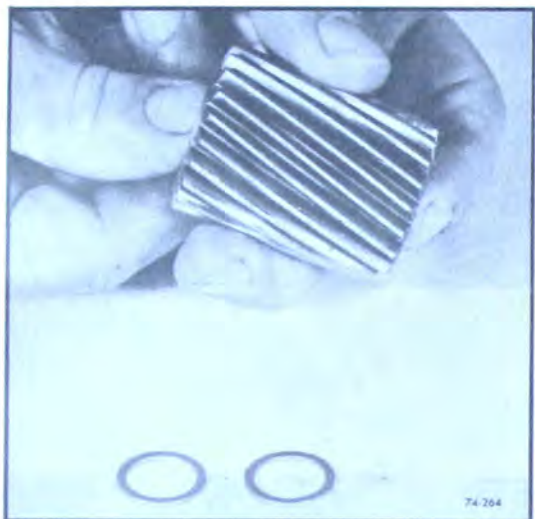

Figure 74-264



Figure 74-265

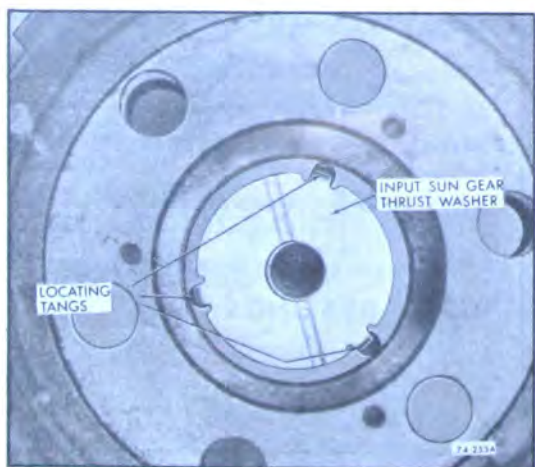

Figure 74-266



Figure 74-267

5. Position the long planet pinion assembly with the thrust washers at each end, in the planet carrier. Install the pinion shaft from the front of the carrier. As the shaft is being pushed in, make certain that it picks up the thrust washer. Turn the pinion shaft so the groove faces the center of the planet carrier. See Figure 74-265.

NOTE: Install the other two (2) long planet pinion gears as described in Steps 2-3-4-5.

6. Install the input sun gear thrust washer with the oil groove facing input sun gear. See Figure 74-266.

7. Install input sun gear into planet carrier. See Figure 74-267.



Figure 74-268

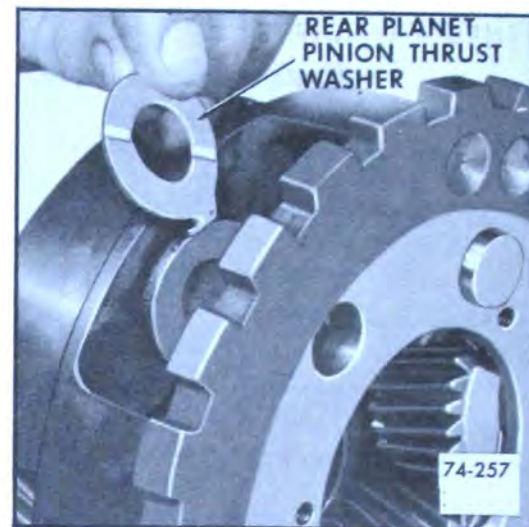

Figure 74-270

8. Install low sun gear needle thrust bearing. See Figure 74-268.

9. Install the rear planet pinion thrust washer. Retain thrust washer with petroleum jelly. Oil groove must be toward pinion gear. See Figure 74-270.

NOTE: The front thrust washer already installed with the long planet pinions also is used for the short planet pinions as the two (2) pinions are paired together on one set of thrust washers.

10. Install twenty (20) needle bearings, and one thrust washer in the pinion gear. See Figure 74-271. With a twisting motion, lock the needle rollers in place. See Figure 74-272.

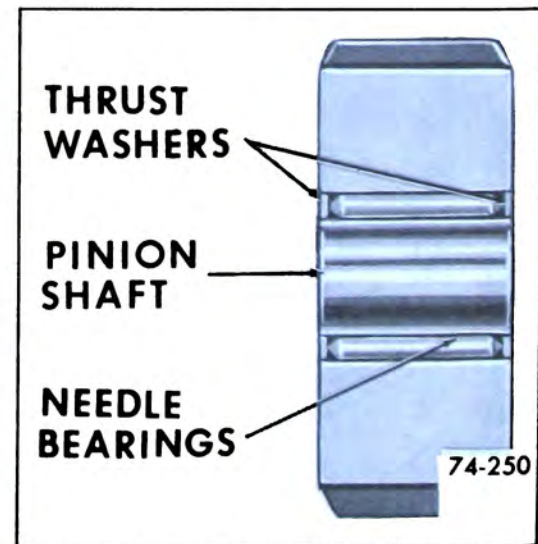

Figure 74-271



Figure 74-272

11. Position short planet pinion assembly and thrust washers at each end of the planet carrier. Install pinion shaft from the front of planet carrier. As the pinion shaft is being pushed in, make certain that it picks up the thrust washers. Turn the pinion shaft so that lock plate groove faces center of planet carrier. See Figure 74-273.

12. Install planet pinion lock plate. Rotate plate so extended portions align with slots in planet pinion shafts, and three (3) attaching screw holes. See Figure 74-274.

13. Install three (3) planet pinion shaft lock plate screws and lock washers. See Figure 74-275.



Figure 74-273

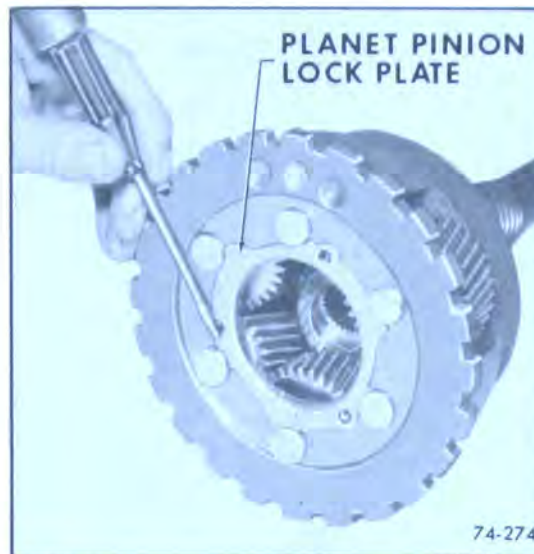

Figure 74-274

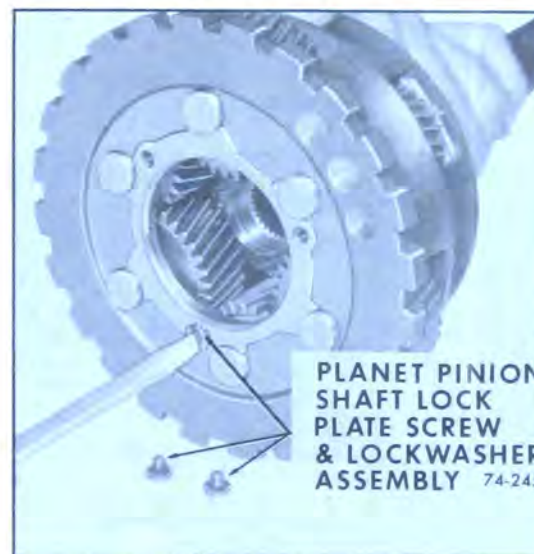

Figure 74-275

74-22 ASSEMBLY OF TRANSMISSION FROM MAJOR PARTS AND UNITS

a. General Instructions

1. Before starting to assemble the transmission make certain that all parts are absolutely clean. Keep hands and tools clean to avoid getting dirt into assembly. If work is stopped before assembly is completed cover all openings with clean cloths.

2. When reassembling it is important that all thrust washer surfaces be given an initial lubrication. Bushings should be lubricated with transmission fluid. Thrust washers should be lubricated on both surfaces with petroleum jelly, (unmedicated) before installation.

3. Do not take a chance on used gaskets and seals - use new ones to avoid oil leaks.

4. Use care to avoid making nicks or burrs on parts, particularly on surfaces where gaskets are used.

5. It is extremely important to tighten all parts evenly and in proper sequence, to avoid distortion of parts and leakage at gaskets and other joints. Use a reliable torque wrench to tighten all bolts and nuts to specified torque and in the specified sequence.

b. Installation of Range Selector Lever, Shaft and Parking Lock Actuator

1. Retain parking pawl and spring in case with parking pawl shaft. See Figure 74-276.



Figure 74-276

NOTE: Position spring as shown.

NOTE: Make certain parking pawl shaft is bottomed in its bore in case.

2. If removed install manual shaft seal using J-9738. See Figure 74-277. Make certain lip of seal points toward center of case.

3. With a twisting motion insert manual shaft into case. See Figure 74-280.

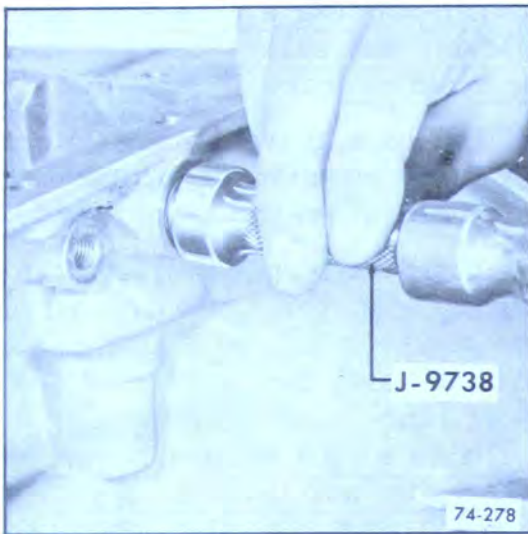

Figure 74-277

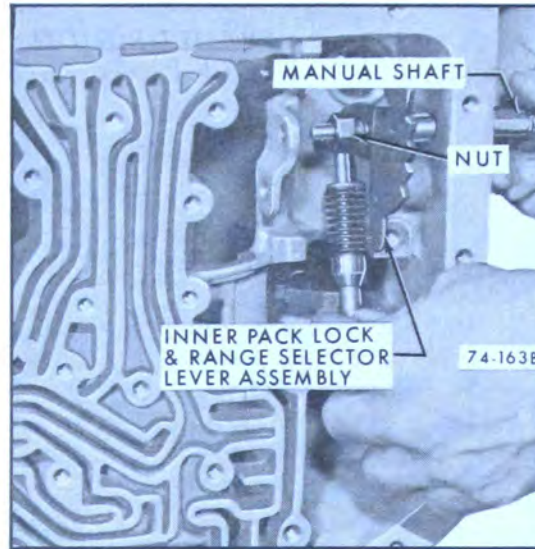

Figure 74-282



Figure 74-285

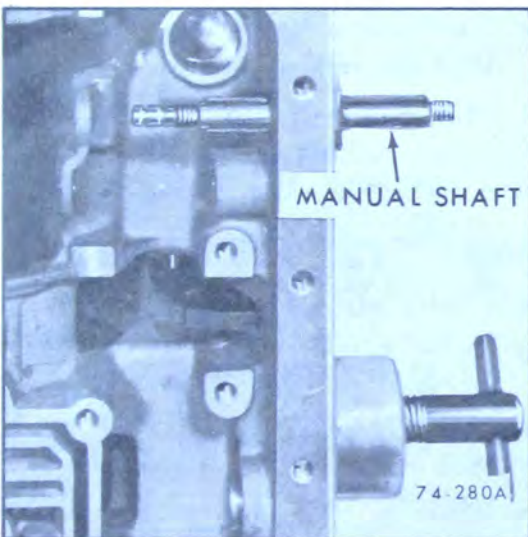

Figure 74-280

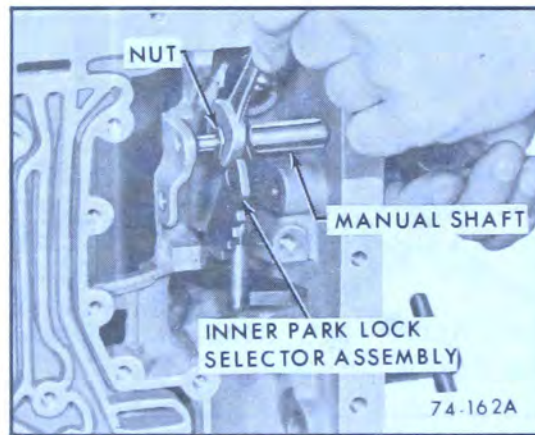

Figure 74-283

4. Assemble park lock actuator assembly to inner park lock and range selector lever. See Figure 74-281.

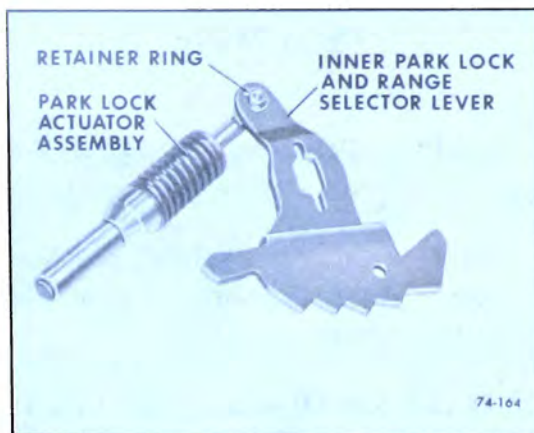

Figure 74-281

5. Install inner park lock and range selector assembly to manual shaft. Install nut on manual shaft. See Figure 74-282.

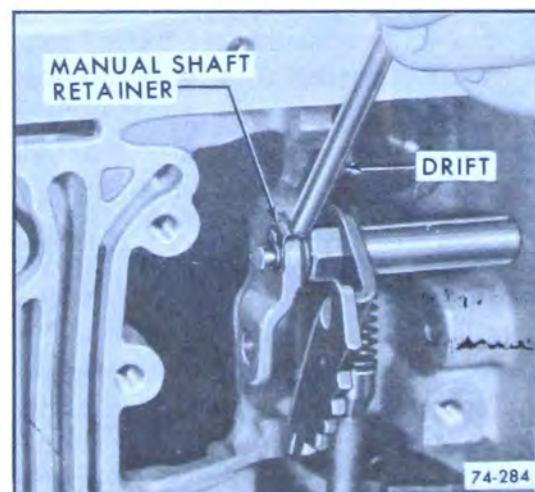

Figure 74-284

6. Slide manual shaft into case and tighten nut. See Figure 74-283.

7. Install manual shaft retainer. See Figure 74-284.

8. Install parking lock bracket to transmission case. Torque bolts to 8-12 lb. ft. See Figure 74-285.

c. Installing Reverse Clutch

1. Lubricate with transmission oil and install reverse clutch piston outer seal. See Figure 74-286.

2. Lubricate with transmission oil and install reverse clutch piston inner seal. See Figure 74-287. Install cushion ring if it was removed.

3. With transmission in vertical position install reverse clutch piston into case. Tap piston with hammer handle to make certain piston is seated in case. See Figure 74-288.



Figure 74-286

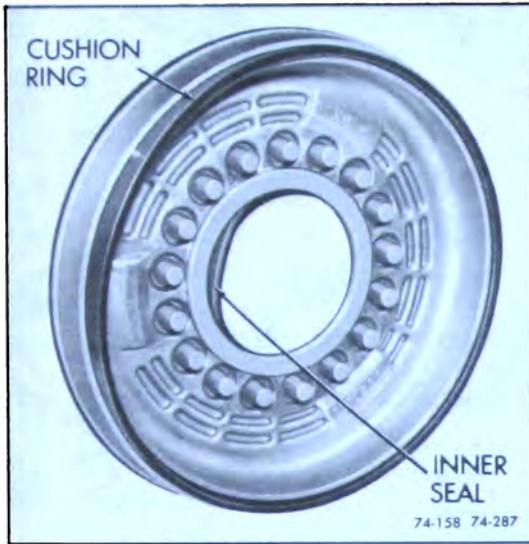

Figure 74-287

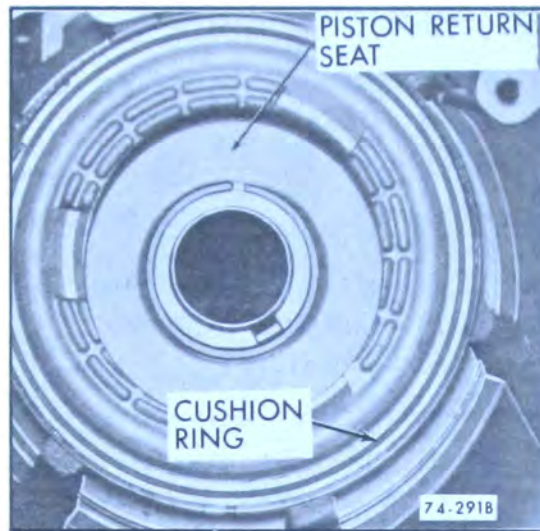

Figure 74-291

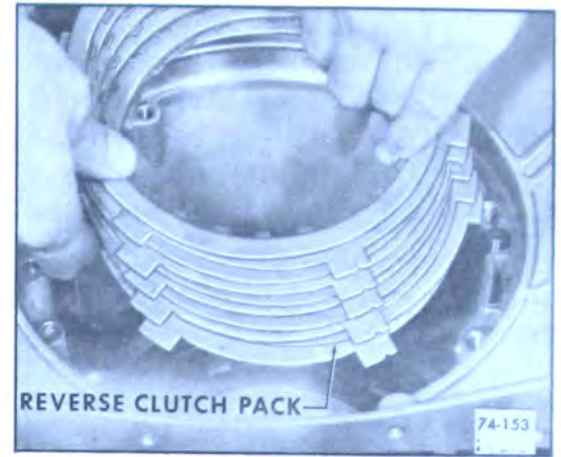

Figure 74-293



Figure 74-288

4. Install seventeen (17) clutch piston return springs. See Figure 74-290.

5. Position piston return seat on piston return springs. Place snap



Figure 74-294

els use 5 drive and 5 driven plates.

8. Install reverse clutch pressure plate with the identification mark being installed in the 5 o'clock groove in case. See Figure 74-294.

9. Install reverse clutch pack snap ring. See Figure 74-295.

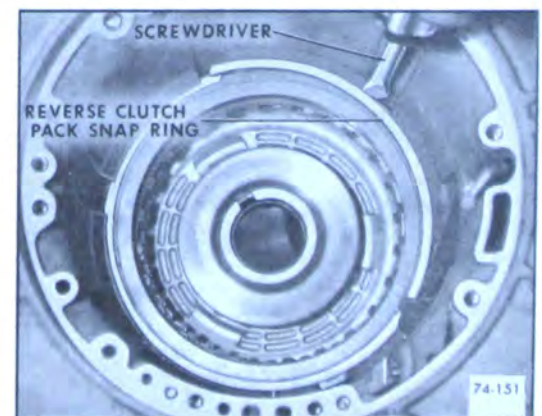

Figure 74-295

ring on return seat so that ring may be easily installed when seat is compressed with tool. See Figure 74-291.

6. Using J-21420-1 and J-21420-2 compress piston return seat so snap ring may be installed with J-5586 Pliers. See Figure 74-292.

CAUTION: As spring retainer is compressed make certain inner edge of retainer does not hang up on snap ring groove.

7. Align notches on the steel driven plates. Install the steel driven plates and lined drive plates alternately, beginning with a steel driven plate. The notched lug on each driven plate goes in the 5 o'clock groove in case. See Figure 74-293.

NOTE: L-6 models use 4 drive and 4 driven plates. V-8 mod-

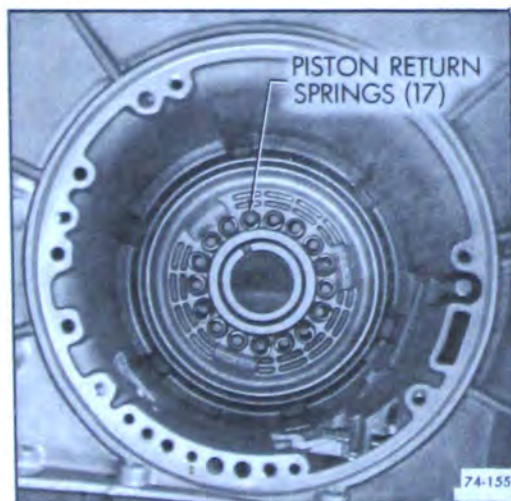

Figure 74-290

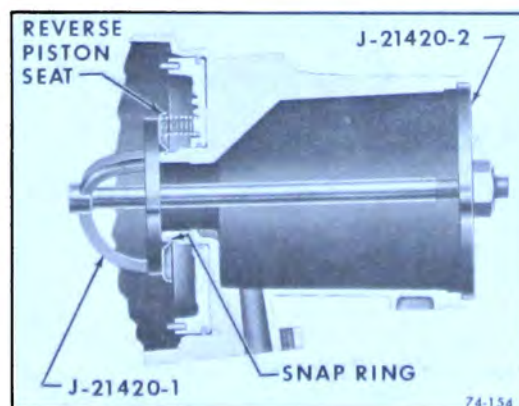

Figure 74-292

d. Installing Planetary Gear Set

1. Install thrust bearing race with lip, needle bearing, and a second plain thrust bearing race to the rear face of the planetary gear set. Retain with grease. See Figure 74-296.

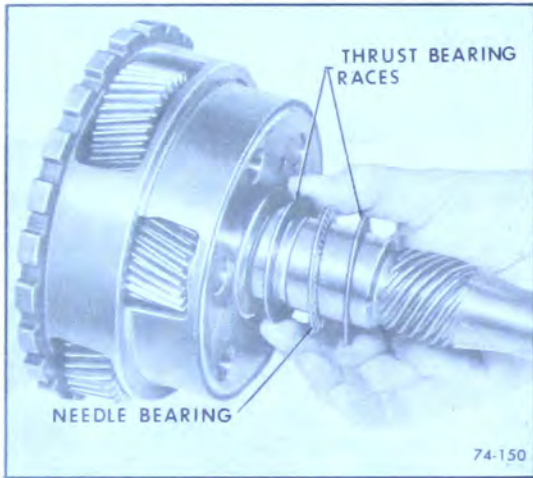

Figure 74-296

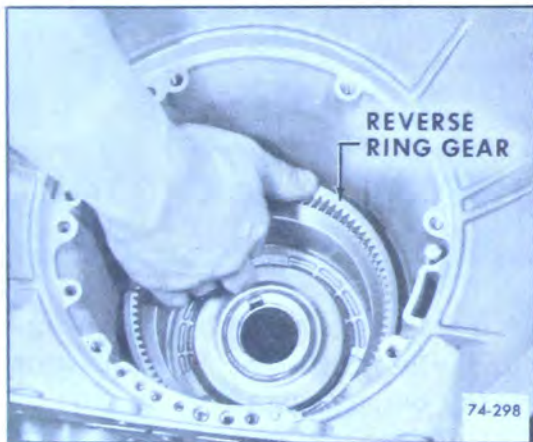

Figure 74-297

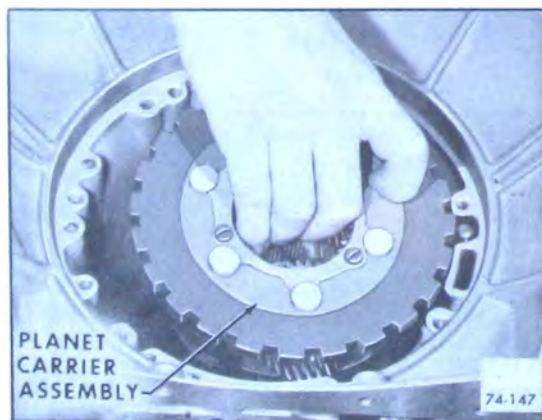

Figure 74-300

2. Install reverse ring gear into case. Turn ring gear to pick up

clutch plate splines. See Figure 74-297.

3. Install planetary gear set into case. See Figure 74-300.

CAUTION: Use extreme care not to damage case bushing.

74-23 INSTALLATION OF LOW SERVO ASSEMBLY, LOW BAND, AND FORWARD CLUTCH

a. Installation of Low Servo

1. Install low servo piston assembly into case. See Figure 74-301.

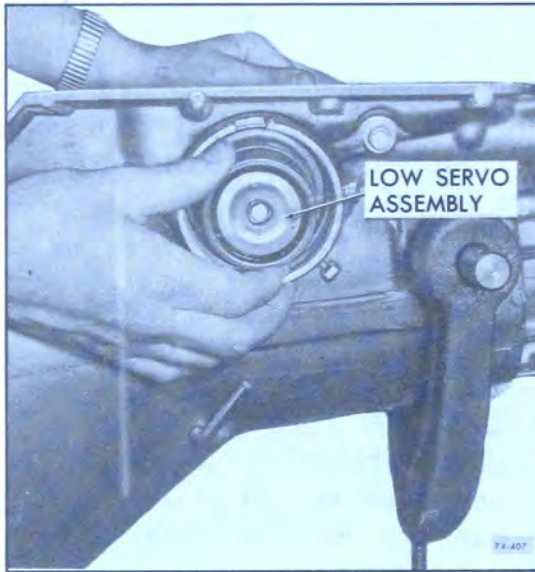

Figure 74-301

2. Install low servo cover oil seal. See Figure 74-302.



Figure 74-302

3. Install low servo cover to case. See Figure 74-303.

4. Compress low servo cover with J-22269 and install retaining snap ring. See Figure 74-304.



Figure 74-303

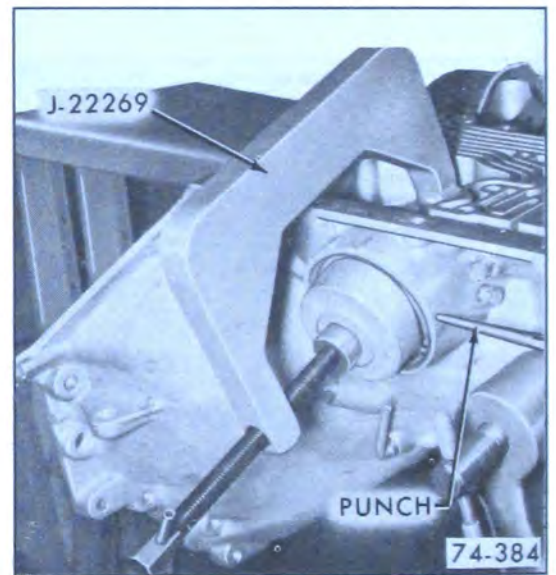

Figure 74-304

b. Installation of Low Band

1. Install low band adjusting screw into case. See Figure 74-305.

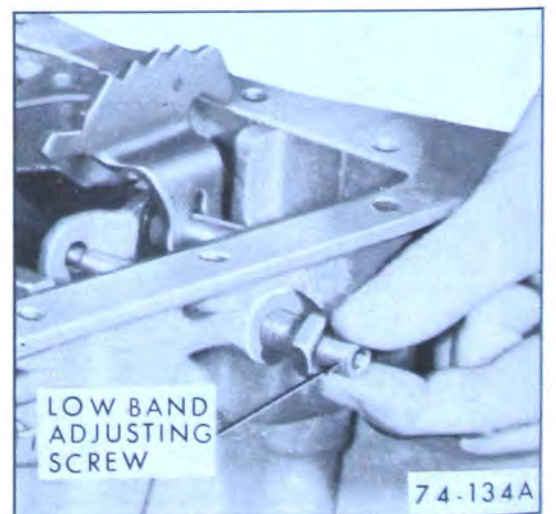

Figure 74-305

2. Install low band into case. See Figure 74-306.

3. Install low band apply strut and band adjusting screw strut. After both struts have been installed, tighten low band adjusting screw enough to prevent struts from falling out. See Figure 74-307.

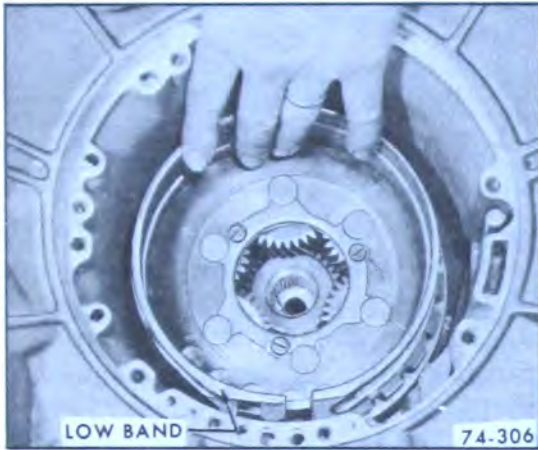

Figure 74-306

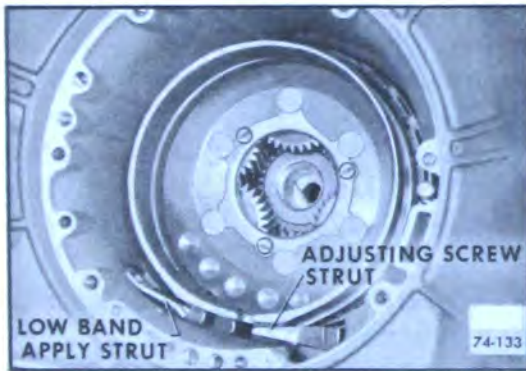

Figure 74-307

c. Installing the Forward Clutch Assembly

1. Install forward clutch assembly turning to engage low sun gear with planet pinions. See Figure 74-310.

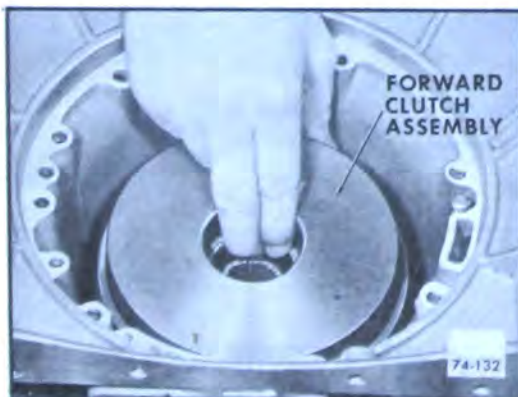

Figure 74-310

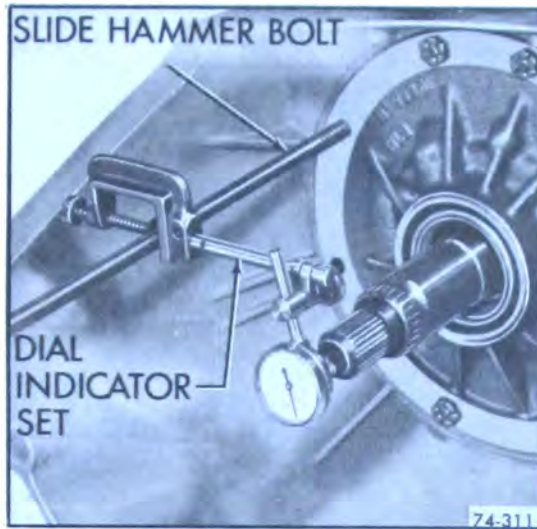

Figure 74-311

d. Check Forward Clutch to Oil Pump Clearance

1. Install guide pins into case. See Figure 74-316.

2. Install pump into case. Remove guide pins and install seven pump to case bolts.

3. Attach slide hammer bolt to threaded hole in oil pump. See Figure 74-311. With flat of hand on end of input shaft move shaft rearward. Install dial indicator set J-8001 on rod and "O" dial indicator on end of input shaft. Push on end of output shaft to move shaft forward, the reading obtained will be the clearance. There are three selective thrust



Figure 74-312

washers available. .099/.095, 081/.077 and .063/.059.

Select washer so the clearance will be between .022" and .054".

4. Remove pump assembly. Install selective fit washer to pump cover hub. See Figure 74-312. Before installation apply petroleum jelly to both sides of washer.

5. Install pump cover to clutch drum oil sealing rings. See Figure 74-313.



Figure 74-313

74-24 INSTALLATION OF OIL PUMP GASKET AND OIL PUMP ASSEMBLY

1. Install oil pump to case seal. See Figure 74-315.



Figure 74-315

2. Install guide pins and new pump gasket. See Figure 74-316.

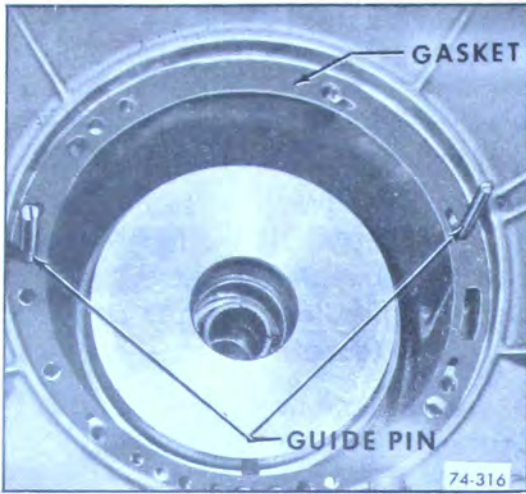

Figure 74-316

3. Install two (2) input shaft oil rings. See Figure 74-317.



Figure 74-317

4. Coat input shaft oil rings with oil and install into oil pump. See Figure 74-318. Then install pump into case. Apply a thin coat of oil around edge of pump.

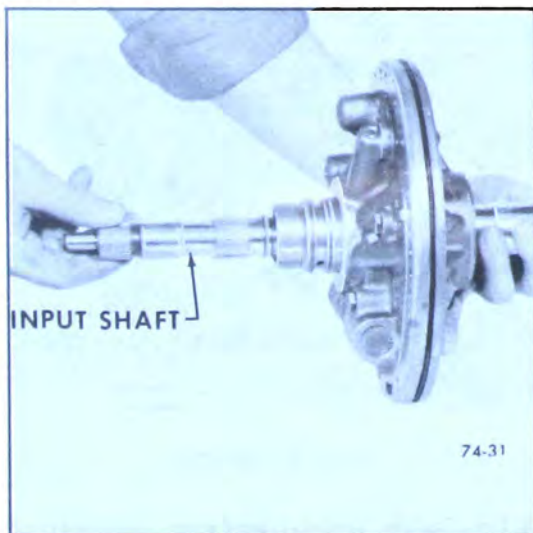

Figure 74-318



Figure 74-320

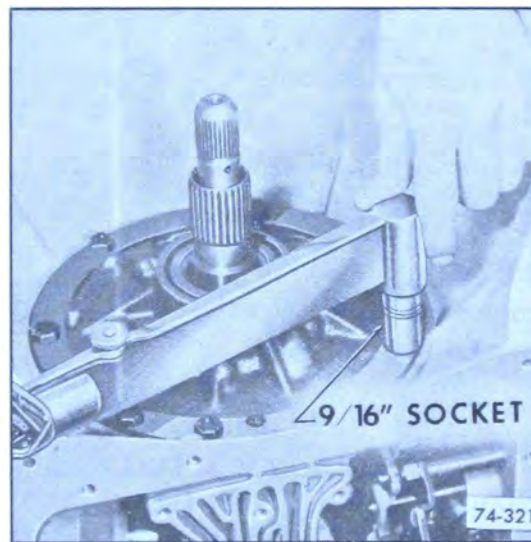

Figure 74-321

5. Remove guide pins and install eight (8) retaining bolts (with new washer type seals under heads). See Figure 74-320.

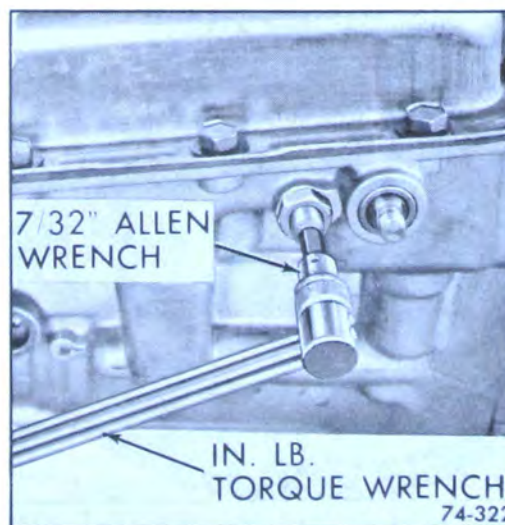

Figure 74-322

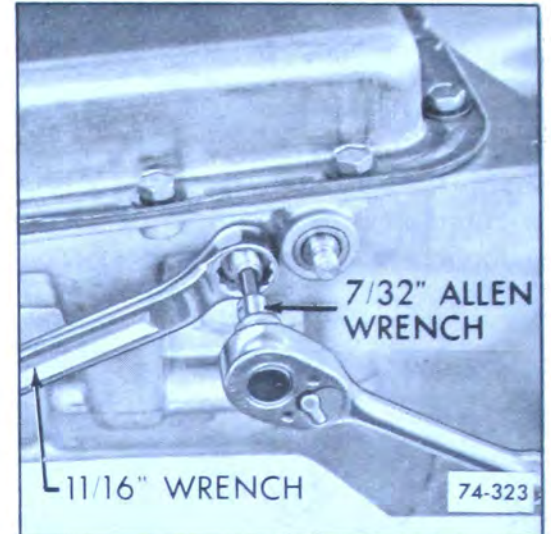

Figure 74-323

6. Torque the eight (8) pump retaining bolts in random sequence to 16-24 lb. ft. See Figure 74-321.

74-25 LOW BAND ADJUSTMENT

1. Remove adjusting screw cap. Adjust low band by first tightening adjusting screw to 40 lb. in. torque. See Figure 74-322.

2. Back off band adjusting screw four (4) turns and lock nut. See Figure 74-323.

3. Install adjusting screw cap. See Figure 74-324.



Figure 74-324

74-26 INSTALLATION OF SPEEDOMETER DRIVE GEAR

1. Place retainer into hole in output shaft. See Figure 74-325.

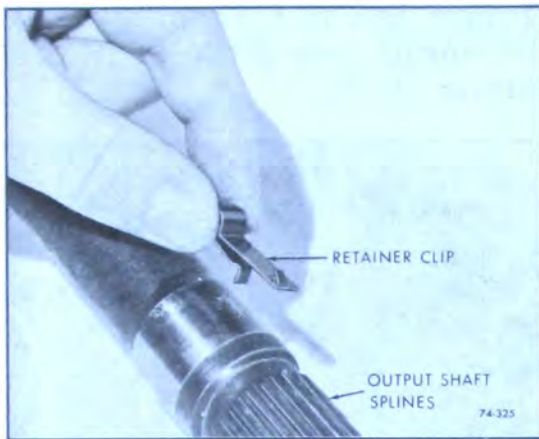

Figure 74-325

2. Align slot in speedometer drive gear with retainer clip and install. See Figure 74-326.

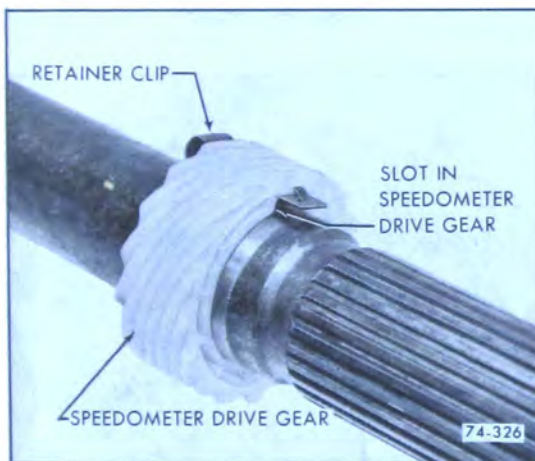

Figure 74-326

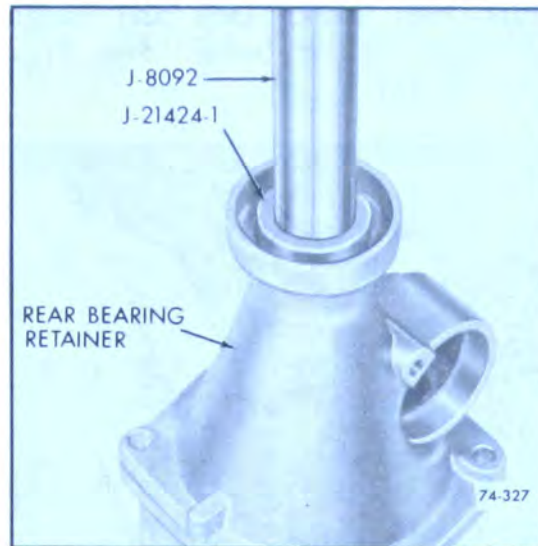

Figure 74-327



Figure 74-328

2. Install rear bearing retainer to case and install four (4) retaining bolts. Torque bolts to 25-35 lb. ft. See Figure 74-331.

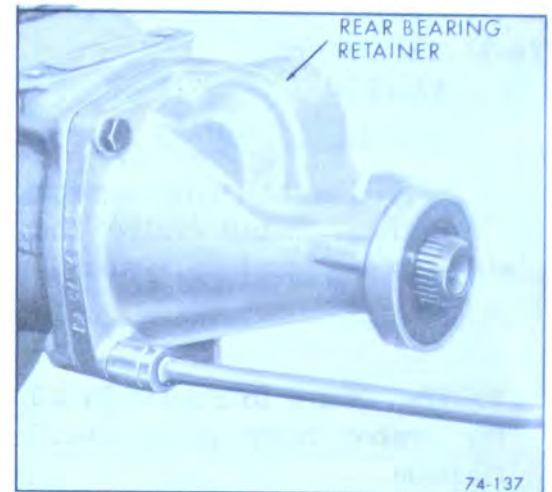

Figure 74-331



Figure 74-332

74-27 INSTALLATION OF REAR BEARING RETAINER BUSHING, OIL SEAL, BEARING RETAINER AND SPEEDOMETER DRIVEN GEAR

a. Installation of Rear Bearing Retainer Bushing

1. Using Drive Handle J-8092 and Installer J-21424-1 install rear bearing retainer bushing. See Figure 74-327.

b. Installation of Output Shaft to Rear Bearing Retainer Oil Seal

1. Install output shaft to rear bearing retainer oil seal using Installer J-21426. See Figure 74-328.

c. Installation of Rear Bearing Retainer

1. Install rear bearing retainer oil seal. See Figure 74-330.



Figure 74-330

d. Installing Speedometer Driven Gear Assembly

1. Install speedometer driven gear sleeve assembly into rear bearing retainer. See Figure 74-332.



Figure 74-333

2. Install speedometer driven gear sleeve retainer. Torque bolt to 5-10 lb. ft. See Figure 74-333.

74-27 INSTALLATION OF VALVE BODY ASSEMBLY

1. With transmission in horizontal position, install valve body plate to case gasket and plate. See Figure 74-334.

NOTE: Refer to Figure 74-335 for valve body plate identification.

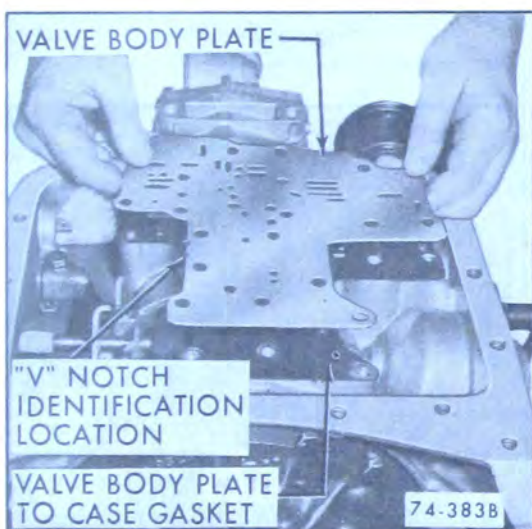

Figure 74-334

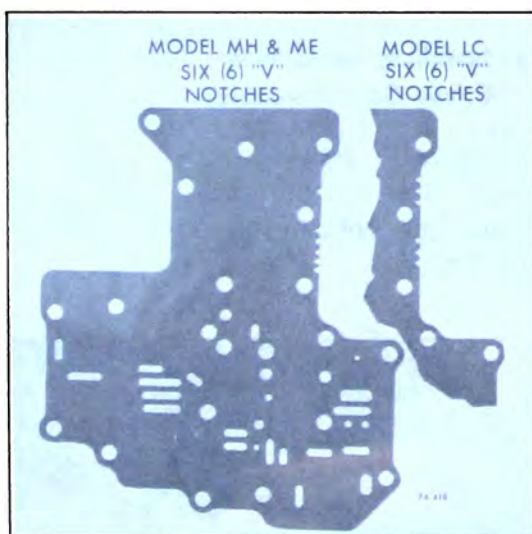

Figure 74-335

2. Install manual control valve and link into valve body assembly. See Figure 74-336.

3. Install manual control valve

link into park, lock and range selector inner lever. See Figure 74-337.

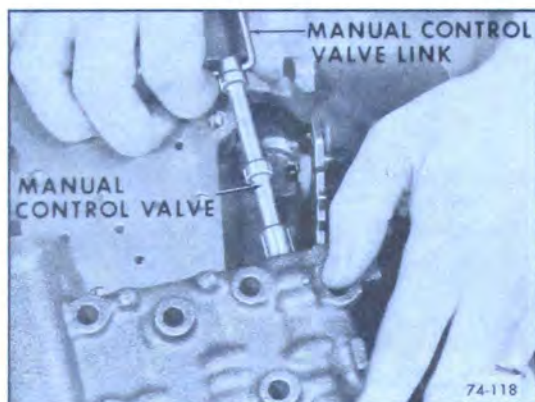

Figure 74-336



Figure 74-337

4. Install eleven (11) valve body to case retaining bolts. Torque bolts in random sequence to 8-11 lb. ft. See Figure 74-338.

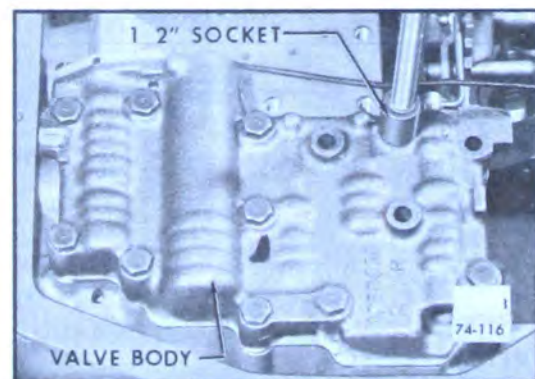

Figure 74-338

5. Install oil channel support plate. Torque bolts in random sequence to 8-12 lb. ft. See Figure 74-339.

6. Install spring detent assembly.

Torque bolt to 8-12 lb. ft. Center spring over detent plate. See Figure 74-340.



Figure 74-339

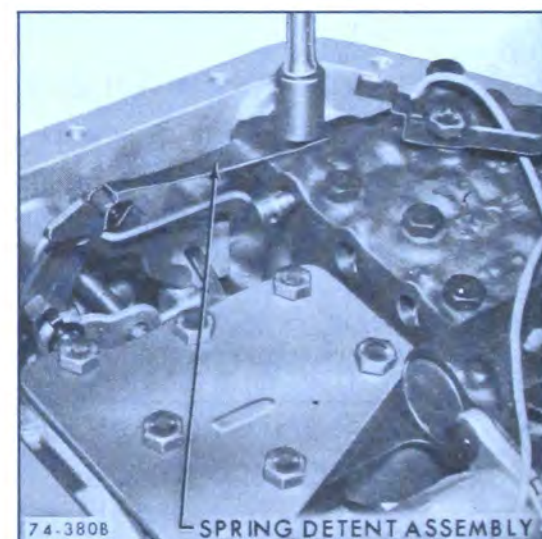

Figure 74-340

7. Install case connector into case. See Figure 74-341.



Figure 74-341

8. Install detent solenoid wire into case connector. See Figure 74-343.

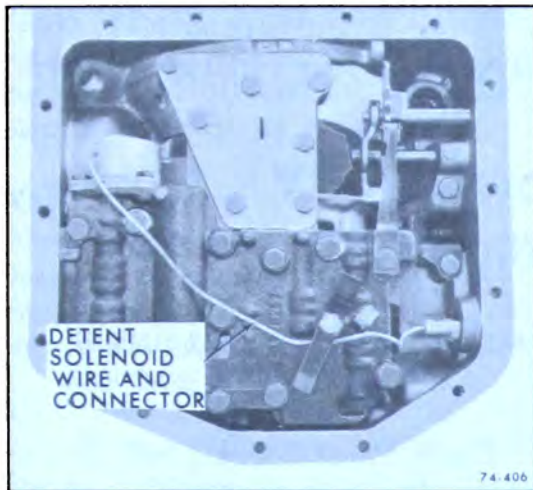

Figure 74-343



Figure 74-344

9. Install new oil strainer pipe to case "O" ring seal.

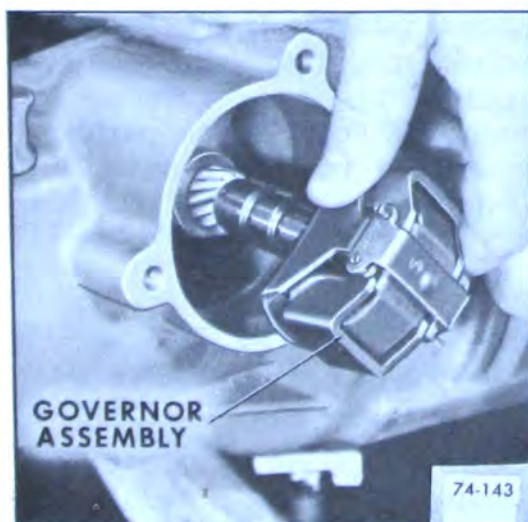

Figure 74-345

10. Install oil strainer and position strainer clip. See Figure 74-344.

11. Install oil pan gasket and pan.

12. Install fourteen (14) oil pan attaching bolts. Torque bolts to 10-16 lb. ft.

74-28 INSTALLATION OF GOVERNOR AND VACUUM MODULATOR

a. Installation of Governor

1. Slide governor into case. Turn governor assembly so teeth on governor gear engage teeth on output shaft. See Figure 74-345.

2. Install governor gasket and cover to case. Torque bolts to 8-12 lb. ft. See Figure 74-346.

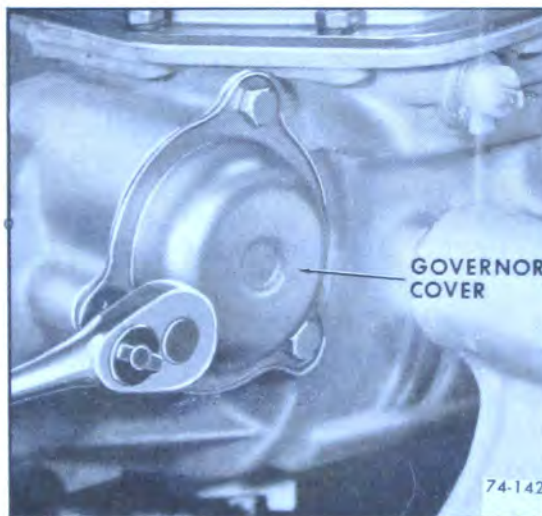

Figure 74-346

b. Installation of Vacuum Modulator

1. Slide rear modulator valve into front modulator valve, then install into case. See Figure 74-351.

2. Install case to vacuum modulator oil seal. See Figure 74-352. Install modulator into case.

3. Install vacuum modulator retainer. See Figure 74-353. Install retainer so tang points toward vacuum modulator. Torque bolt to 8-12 lb. ft.

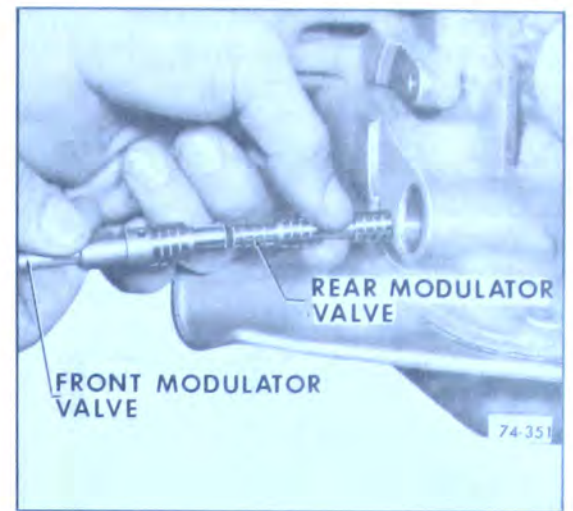

Figure 74-351



Figure 74-352

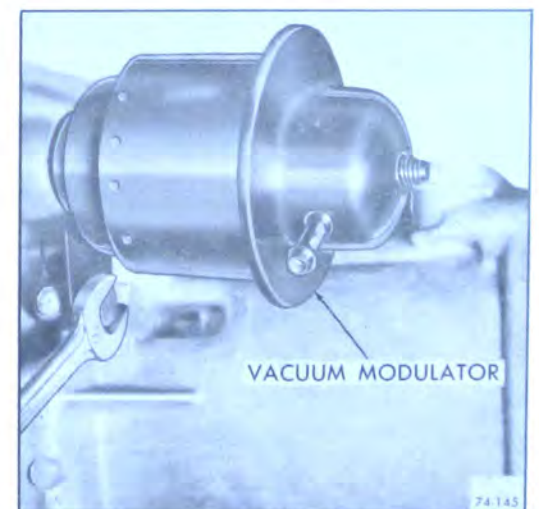

Figure 74-353

74-29 CONVERTER CHECKING PROCEDURE

1. Check converter for leaks as follows:

a. Install Tool J-21369 and tighten. See Figure 74-354.

b. Fill converter with air; 80 psi.



Figure 74-354



Figure 74-355



Figure 74-356



Figure 74-357

c. Submerge in water and check for leaks.

2. Check converter end clearance as follows:

a. Install Tool J-21371-2 and tighten brass nut. See Figure 74-355.

b. Install Tool J-21371-3 and tighten hex nut. See Figure 74-356.

c. Install dial indicator set at 0.

d. Loosen hex nut. See Figure 74-357. When nut is fully loosened the reading obtained on the dial indicator will be converter end clearance. If clearance is .050" or over and the oil has the appearance of having been mixed with aluminum paint, replace the converter.



Figure 74-358

3. Install converter. See Figure 74-358.

4. Install converter holding Tool J-21366.

5. Refer to Paragraph 74-1, Subparagraph c, for refill procedures.

DIVISION IV TROUBLE DIAGNOSIS

74-30 SEQUENCE FOR SUPER TURBINE 300 TRANSMISSION DIAGNOSIS

1. Check and correct oil level. Refer to Paragraph 74-1, Subparagraph c, for checking for refill procedures.

2. Check detent switch. See Figure 74-2.

3. Check and correct vacuum line and fittings.

4. Check and correct manual linkage. See Group 73.

5. Road test car.

a. Install oil pressure gage.

b. Road test using all selective ranges, noting when discrepancies in operation or oil pressure occur.

c. Attempt to isolate the unit or circuit involved in the malfunction.

d. If engine performances indicates an engine tune-up is required, this should be performed before road testing is completed or transmission correction attempted. Poor engine performance can result in rough shifting or other malfunctions.

74-31 SUPER TURBINE 300 TRANSMISSION OIL CHECKING PROCEDURES

Before diagnosis of any transmission complaint is attempted, there must be an understanding of oil checking procedures and what

appearance the oil should have. Many times a transmission malfunction can be traced to low oil level, improper reading of dipstick, or oil appearance; therefore, a careful analysis of the condition of oil and the level may eliminate needless repairs.

When checking oil level in the Super Turbine 300 Transmission, the procedure outlined in Paragraph 74-1, Subparagraph c, to obtain the most accurate reading.

Also, when the dipstick is removed, it should be noted whether the oil is devoid of air bubbles or not. Oil with air bubbles gives an indication of an air leak in the suction lines, which can cause erratic operation and slippage. Water in the oil imparts a milky, pink cast to the oil and can cause spewing.

74-32 EXTERNAL OIL LEAKS

a. Determining Source of Oil Leak

Before attempting to correct an oil leak, the actual source of the leak must be determined. In many cases, the source of the leak can be deceiving due to "wind flow" around the engine and transmission.

The suspected area should be wiped clean of all oil before inspecting for the source of the leak. Red dye is used in the transmission oil at the assembly plant and will indicate if the oil leak is from the transmission.

The use of a "Black Light" to locate the point at which the oil is leaking is helpful. Comparing the oil from the leak to that on the engine or transmission dipstick, when viewed by black light, will determine the source of the leak - engine or transmission.

Oil leaks around the engine and transmission are generally carried toward the rear of the car by the air stream. For example,

a transmission oil filler tube to case leak will sometimes appear as a leak at the rear of the transmission. In determining the source of a leak, proceed as follows:

1. Degrease underside of transmission.

2. Road test to get unit at operating temperature.

3. Inspect for leak with engine running.

4. With engine off, check for oil leaks due to the raised oil level caused by drain back.

b. Possible Points of Oil Leaks

1. Transmission Oil Pan Leak

a. Attaching bolts not correctly torqued.

b. Improperly installed or damaged pan gasket.

c. Oil pan gasket mounting face not flat.

2. Rear Bearing Retainer

a. Attaching bolts not correctly torqued.

b. Rear seal assembly damaged or improperly installed.

c. Square seal, extension to case, damaged or improperly installed.

d. Porous casting. See subparagraph c.

3. Case Leak

a. Filler pipe "O" ring seal damaged or missing; misposition of filler pipe bracket to engine.

b. Modulator assembly "O" ring seal damaged or improperly installed.

c. Solenoid connector "O" ring seal damaged or improperly installed.

d. Governor cover bolts not

torqued, gasket damaged or leak between case face and gasket.

e. Speedometer gear "O" ring damaged.

f. Manual shaft seal damaged or improperly installed.

g. Line pressure tap plug loose.

h. Vent pipe (refer to item 5).

i. Porous casting. See subparagraph c.

4. Leak at Front of Transmission

a. Front pump seal leaks.

(1) Seal lip cut. Check converter hub, etc.

(2) Bushing moved and damaged. Oil return hole plugged.

(3) No oil return hole.

b. Front pump attaching bolts loose or bolt "O" rings damaged or missing.

c. Front pump housing "O" ring damaged or cut.

d. Converter leak in weld area.

e. Porous casting (pump).

5. Oil Comes Out Vent Pipe

a. Transmission over-filled.

b. Water in oil.

c. Foreign material between pump and case or between pump cover and body.



Figure 74-360

d. Case - porous near converter bosses. Front pump cover or housing oil channels shy of stock near breather. See subparagraph c.

e. Pump to case gasket mispositioned.

c. Case Porosity Repair

Super Turbine 300 transmission external oil leaks caused by case porosity can be successfully repaired with the transmission in the car by using the following recommended procedures:

1. Road test and bring the trans-

mission to operating temperature, approximately 180°F.

2. Raise car on a hoist or jack stand, engine running, and locate source of oil leak. Check for oil leaks in Low, Drive, and Reverse.

NOTE: Use of a mirror is helpful in finding leaks.

3. Shut engine off and thoroughly clean area to be repaired with a suitable cleaning solvent and a brush - air dry.

NOTE: A clean, dry soldering acid brush can be used to clean the area and also to apply the epoxy cement.

4. Using instructions of the manufacturer, mix a sufficient amount of epoxy, Group 0.423, Part No. 1360016, to make the repair.

NOTE: Observe cautions in handling.

5. While the transmission case is still HOT, apply the epoxy to the area to be repaired.

NOTE: Make certain the area to be repaired is fully covered.

6. Allow cement to cure for 3 hours before starting engine.

7. Road test and check for leaks.

74-33 SUPER TURBINE 300 TROUBLE DIAGNOSIS CHART

PROBLEM	PROBABLE REMEDY
I. No Drive in Any Selector Position	<ul style="list-style-type: none"> a. Check oil level. See paragraph 74-1. b. Check oil pressure as described in paragraph 74-35. c. Check manual shift linkage adjustment. d. Check internal linkage. e. Check for defective pressure regulator valve. f. Check for pressure regulator valve retaining ring out of groove. g. Check for defective front pump.
II. Erratic Operation and Slippage (Light to Medium Acceleration)	<ul style="list-style-type: none"> a. Check screen and suction pipe assembly for leaks. b. Check suction pipe "O" ring. c. Low oil level. d. Check for defective modulator. See Paragraph 74-34.
III. Excessive Slip or Engine Flare on Coasting to a Stop or When Cornering	<ul style="list-style-type: none"> a. Check engine idle. See paragraph 64-2. b. Check for suction leak as described in item II. c. Check low band adjustment. See paragraph 74-25. d. Check for proper modulator can assembly See paragraph 74-1.

74-33 SUPER TURBINE 300 TROUBLE
DIAGNOSIS CHART (Cont'd)

PROBLEM	PROBABLE REMEDY
<p>III. Excessive Slip or Engine Flare on Coasting to a Stop or When Cornering (Cont'd.)</p>	<p>e. Check for defective modulator can -- no bellows load. See paragraph 74-34.</p>
<p>IV. No Reverse</p>	<p>a. Check reverse clutch piston seals. b. Check freedom of reverse clutch piston. c. Check for open feed lines to reverse clutch. See Figures 74-366 through 74-373. d. Loose oil channel support plate attaching bolts. Specification is 8-12 lb. ft.</p>
<p>V. Slips (In Any Range)</p>	<p>a. Refer to items II and XVIII.</p>
<p>VI. Harsh Neutral to Drive Shift at Idle</p>	<p>a. Check vacuum line connections. b. Check engine idle speed. See paragraph 64-2.</p>
<p>VII. No Upshift</p>	<p>a. On "no upshift" complaints, road test car or check on a twin post host by accelerating slowly to approximately 65 MPH. If a shift occurs at approximately 65 MPH, look for:</p> <ol style="list-style-type: none"> 1. Open detent solenoid 2. Loose detent solenoid attaching bolts 3. Stuck detent valve 4. No vacuum to modulator <p>b. If no shift occurs, look for:</p> <ol style="list-style-type: none"> 1. Governor* 2. Stuck shift valve or shift control valve. <p>c. If transmission has "no upshift" cold but is satisfactory when warm, look for a stocky shift valve or shift control valve and improper bolt torque (spec. 8-12 lb. ft.)</p>

*If a gage is installed, the governor can be checked as follows: Depress accelerator to a fixed position, approximately 1/4 throttle. With the accelerator kept at this fixed position, line pressure will drop with increasing car speed.

74-33 SUPER TURBINE 300 TROUBLE
DIAGNOSIS CHART (Cont'd)

PROBLEM	PROBABLE REMEDY
VIII. Long Shift Time--Shift Does Not Have Positive Engagement	<ul style="list-style-type: none"> a. Check for proper modulator can assembly. See paragraph 74-1. b. Check for leak in clutch circuit. See Figures 74-366 through 74-373. c. Check valve body port between modulator boost and clutch feed in shift valve bore. See Figure 74-373. d. If foreign material in oil pan indicates a clutch failure, replace clutch plates and necessary parts.
IX. Engine Flares on Upshift	<ul style="list-style-type: none"> a. Refer to item XVI.
X. Late Upshift	<ul style="list-style-type: none"> a. Check vacuum line connections. b. Stuck detent valve.* c. Open detent solenoid or loose solenoid attaching bolts* d. Sticky shift valve. e. Check governor assembly. See paragraph 74-20. f. If upshifts occur late cold, but are satisfactory warm, check for no roll pin in governor pinion or improper valve body bolt torque (Spec. 8-12 lb. ft.)
*Transmission will upshift only at wide-open throttle.	
XI. Upshifts-Downshifts Erratic	<ul style="list-style-type: none"> a. Refer to paragraph 74-20. b. Refer to item II. c. Scored governor bore.
XII. No Wide Open Throttle Downshift	<ul style="list-style-type: none"> a. Check detent control switch for continuity in wiring. (Wiring fused with windshield wiper.)

**74-33 SUPER TURBINE 300 TROUBLE
DIAGNOSIS CHART (Cont'd)**

PROBLEM	PROBABLE REMEDY
<p>XII. No Wide Open Throttle Downshift (Cont'd.)</p>	<ul style="list-style-type: none"> b. Check for stuck detent valve and shift valves. c. Check orifice in detent valve. d. Check detent solenoid on valve body.
<p>XIII. Engine Flares on Wide Open Throttle Downshift</p>	<ul style="list-style-type: none"> a. Check low band adjustment. See paragraph 74-25. b. Check item XVII. c. Check for restriction in vacuum line or fitting to transmission. d. Check for correct valve body plate. See chart in Paragraph 74-1, subparagraph a.
<p>XIV. Delayed Engagement of Manual Low</p>	<ul style="list-style-type: none"> a. Check freedom of 2-piece modulator valve.
<p>XV. Oil Spews Out Breather</p>	<ul style="list-style-type: none"> a. High oil level. b. Water in oil. c. Chip or burr between pump cover and housing or between complete pump assembly and case. d. Direct leak from front pump pressure line into vent chamber. See Figure 74-367.
<p>XVI. Drive Clutch Plates Burned (Usually Low Band and Reverse Clutch Good)</p>	<ul style="list-style-type: none"> a. Check for leakage in clutch circuit. See Figures 74-366 through 74-373. b. Check ball in forward clutch drum. c. Clutch lines in front pump cover and stator shaft assembly. See Figure 74-367. d. Plug in pump cover assembly missing. See Figure 74-374. e. Clutch piston seals. f. Clutch feed oil rings.

74-33 SUPER TURBINE 300 TROUBLE DIAGNOSIS CHART (Cont'd)

PROBLEM	PROBABLE REMEDY
<p>XVI. Drive Clutch Plates Burned (Usually Low Band and Reverse Clutch Good (Cont'd.)</p>	<p>g. Check for proper number of clutch plates and correct piston. See Paragraph 74-1.</p>
<p>XVII. Drive Clutch Plates, Low Band and Reverse Clutch Plates--All Burned</p>	<p>a. Check the following causes of low maximum line pressure.</p> <ol style="list-style-type: none"> 1. Modulator can load check. See Paragraph 74-34. 2. Check for proper modulator can. See chart on page 74-1. 3. Check modulator valve and bore in case for freedom or movement. 4. Check freedom of boost valve in front pump regulator. <p>b. Valve body bolts loose. Torque specification is 8-12 lb. ft.</p> <p>c. Low oil level.</p>

The V-8 pressures are approximately 60 psi at idle and 145 psi at zero output speed with the vacuum modulator line disconnected from the modulator assembly and with the engine at 1000 RPM. See Chart below.

The L-6 pressures are approximately 60 psi (see chart on Page 74-68 for exact pressure) at idle and 135 psi at zero output speed with the vacuum modulator line disconnected from the modulator assembly and with the engine at 1000 RPM.

If the 60 psi are not being obtained, check the pressure regulator valve, spring and shims and the front pump gears. These are the only parts which affect the minimum line pressure.

If the 135-140 are not being obtained, check the following parts in the complete modulator circuit:

1. Modulator can bellows.
2. Front pump boost valve and sleeve.

3. Oil channel lines to above.
4. Modulator valve.

74-34 VACUUM MODULATOR DIAGNOSIS PROCEDURE

NOTE: A defective vacuum modulator can cause one

or more of the following complaints.

1. Harsh upshifts and downshifts
2. Delayed upshifts
3. Soft upshifts and downshifts
4. Delayed engagement of low band on a downshift.

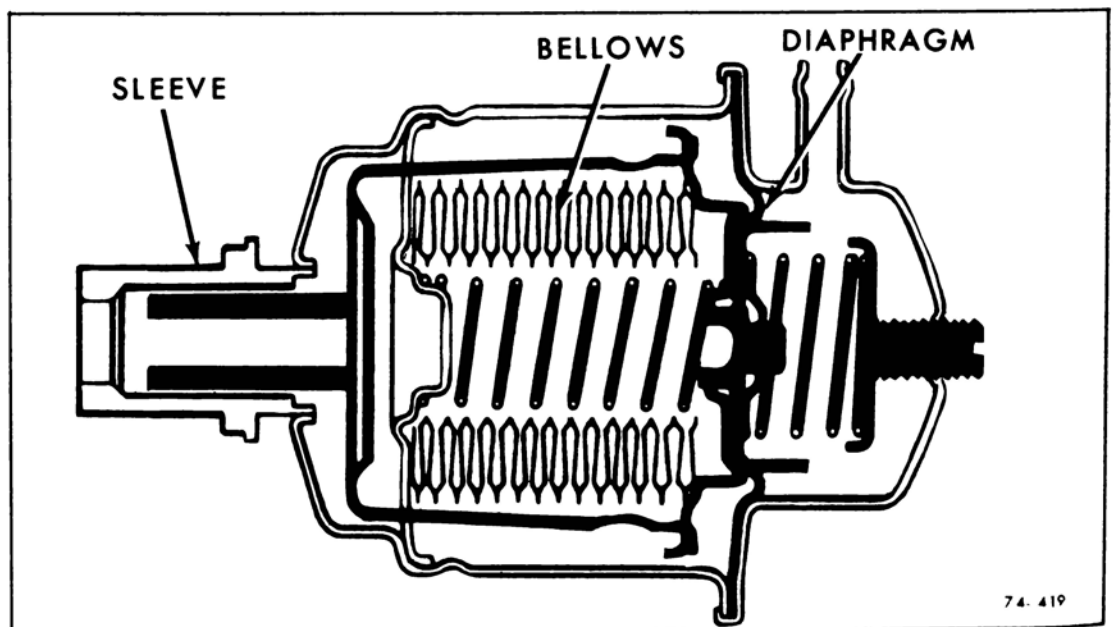

Figure 74-361—Vacuum Modulator Assembly

5. Slips in low, drive and reverse
6. Transmission overheating
7. Engine burning transmission oil

If any one of the above complaints are encountered, the modulator must be checked.

The vacuum modulator, See Figure 74-361, has three areas to be checked. If any one of the three (3) areas fail to pass the prescribed checks, the modulator must be replaced.

1. Bellows Comparison Check

Using a comparison gage, furnished with Dealer Service Information Bulletin 67-I-37, compare the load of a known good modulator of the same part number with the modulator in question.

NOTE: Refer to modulator usage chart in Paragraph 74-1, Subparagraph a.

To check bellows load proceed as follows:

- a. Insert one end of the comparison gage into the suspected defective modulator sleeve. Insert the opposite end of the gage into a known good modulator of the same part number as the suspected defective modulator.

NOTE: Refer to modulator usage chart in Paragraph 74-1, Subparagraph a.

NOTE: The part number of the modulator assembly is located on the back side of the modulator.

- b. Holding the modulators in a horizontal position, see Figure 74-362, bring them slowly together under pressure. The modulator bellows in question, if defective, will reach the center line of the comparison gage before the known good modulator lines up with the outer gauge line. See Figure 74-363.

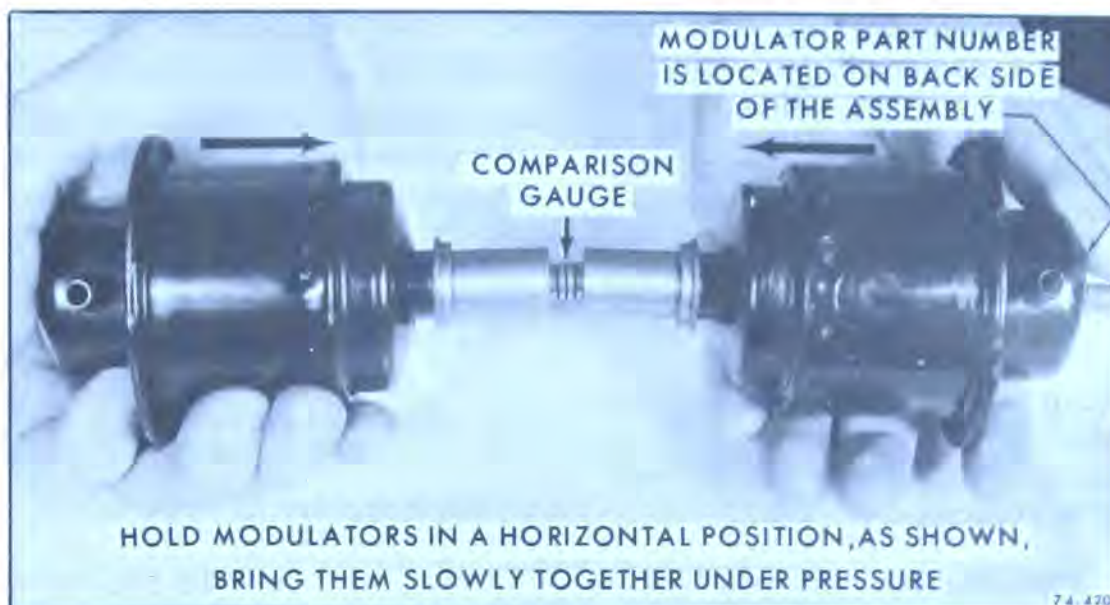

Figure 74-362—Holding Modulator in Horizontal Position

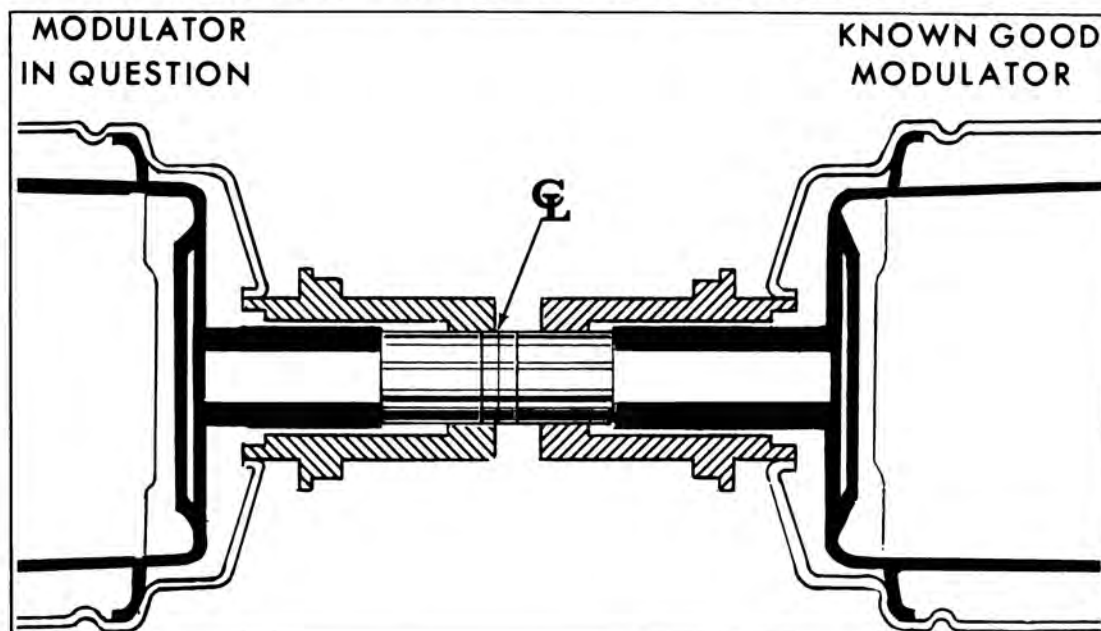

Figure 74-363—Modulator Bellows Bad

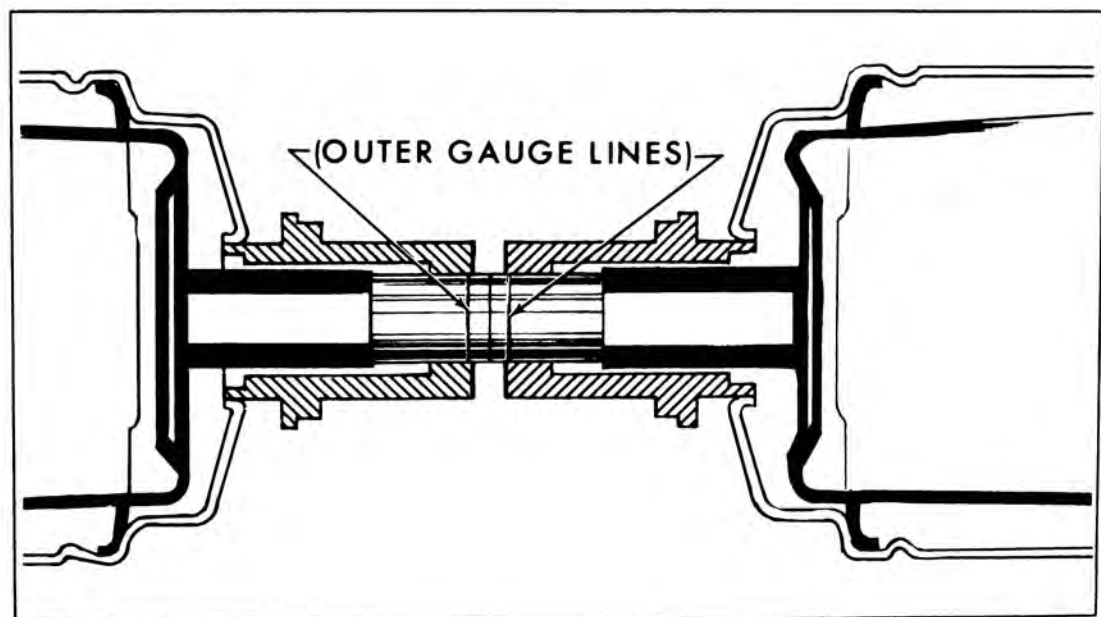

Figure 74-364—Modulator Bellows Good

If the modulator bellows in question is good, both modulator assemblies will be within the outer gage lines as the assemblies are slowly brought together. See Figure 74-364.

2. Vacuum Diaphragm Leak Check

Turn modulator so vacuum line stem points downward. If transmission oil comes out the vacuum diaphragm is defective.

IMPORTANT: Gasoline and/or water vapor may settle in the vacuum side of the modulator. If this is found WITHOUT the presence of oil the modulator **MUST NOT BE CHANGED.**

Check solution that comes out of the modulator for evidence of lubricity. If the solution does not have the feel of oiliness it can be assumed the solution is a mixture of gas and/or water. The only way transmission oil can be on the vacuum side of the modulator

is by a leak in the vacuum diaphragm.

If oil is found, the modulator must be replaced. If oil is not found in the vacuum side of the modulator but the transmission oil level is continually low, and NO external leaks are found, there is a possibility that a pin hole leak exists in the diaphragm and the modulator should be replaced.

3. Inspection for External Damage

1. Check for dents or cracks in modulator.

2. Check modulator valve sleeve alignment. Roll modulator on a flat surface to determine if the sleeve is concentric to the modulator can. See Figure 74-365. If the sleeve is bent, runout will be visible, and modulator must be replaced.

If the modulator passes the above checks, the following items should also be checked as a possible

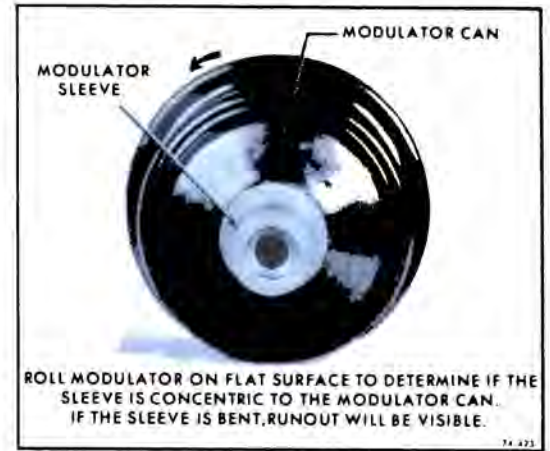

Figure 74-365—Checking Modulator Sleeve Alignment

cause of the problem.

1. Check freeness of modulator valve in modulator.

2. Check freeness of modulator valve in transmission case.

3. Check the vacuum line from the manifold to modulator for holes, cracks or dents. Check the rubber hose connections at the modulator and at the intake manifold for leaks.

74-35 HYDRAULIC PRESSURE CHECKS

SUPER TURBINE 300
TRANSMISSION PRESSURE CHECKS

MAXIMUM LINE PRESSURE CHECKS are to be made in the garage bay with the vacuum modulator line disconnected and plugged. The engine speed set at 1000 RPM.

Altitude	Barometric Pressure (in. Hg.) at Standard Conditions*	Model LC Vacuum Modulator Part No. 1367032		Model MH and ME Vacuum Modulator Part No. 8623947	
		D and L ± 4 psi	R ± 6 psi	D and L ± 4 psi	R ± 6 psi
		Sea Level	29.92	160	243
2,000 ft.	27.82	152	230	161	244
5,000 ft.	24.89	138	210	148	224
10,000 ft.	20.58	119	180	129	195

(Chart cont'd on Page 74-69)

MINIMUM LINE PRESSURE CHECKS are to be made while road testing car. The vacuum modulator line connected. Engine and/or car speed as shown in note below.**

MINIMUM LINE PRESSURE CHECKS FOR ALL MODELS REGARDLESS OF VACUUM MODULATOR USED. (Pressures not affected by Altitude or Barometric Pressure)

PARK, NEUTRAL, and DRIVE	56 ± 2 psi
LOW	99 ± 4 psi
REVERSE	85 ± 4 psi

*Line pressures vary 3.5 psi for each 1 in. Hg. change in Barometric Pressure.

**Minimum line pressure checks to be made as follows:

1. Drive - 20-40 MPH coast with foot off throttle. Park and Neutral can be checked at 1000 RPM.
2. Low - 20-40 MPH coast with foot off throttle.
3. Reverse - Coast with foot off throttle.

NOTE: PRESSURE TAP IS LOCATED BESIDE THE LOW SERVO COVER. See Figure 74-374

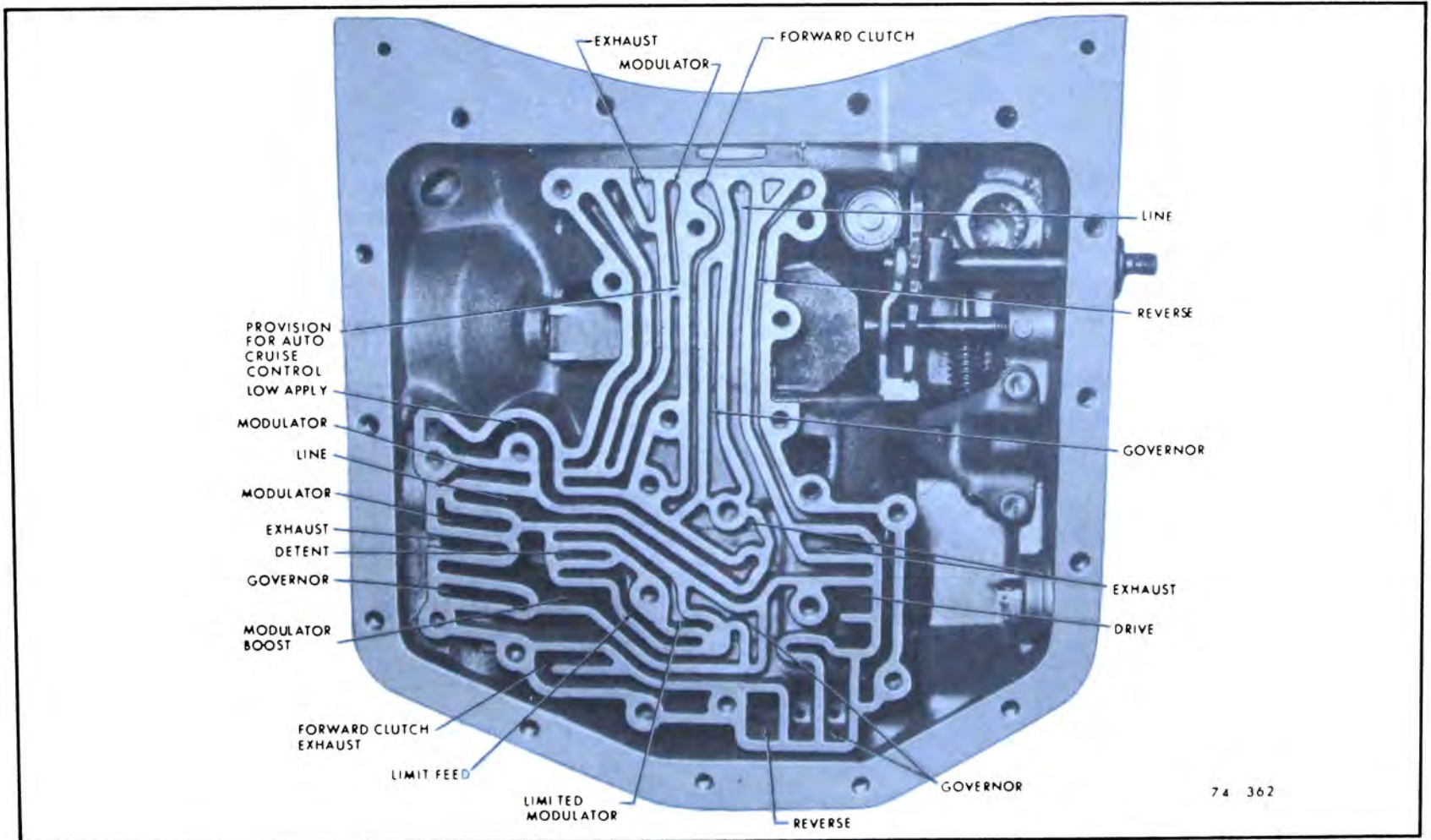

Figure 74-366—Oil Passages in Bottom of Transmission Case

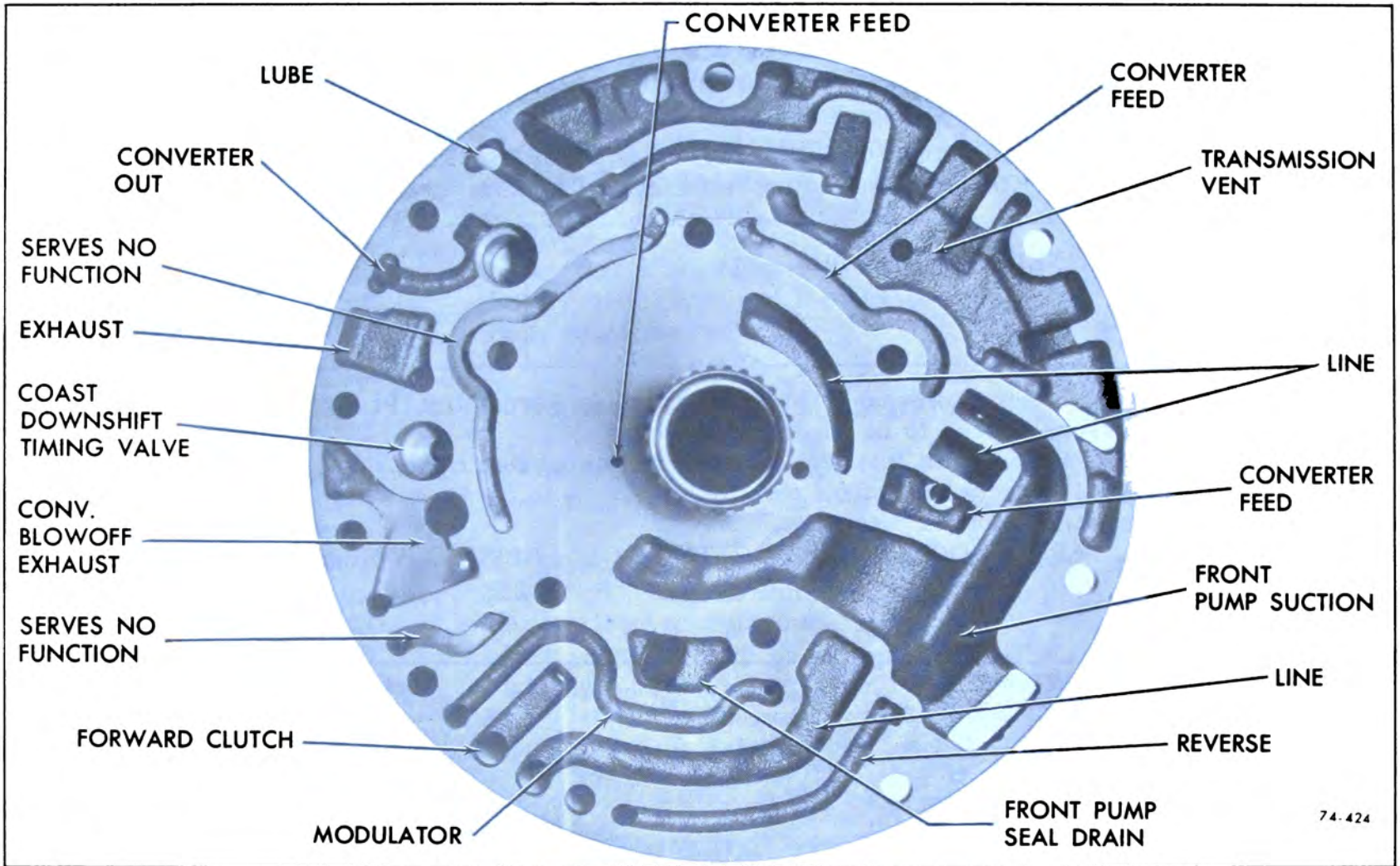

Figure 74-367—Oil Passages in Pump Cover

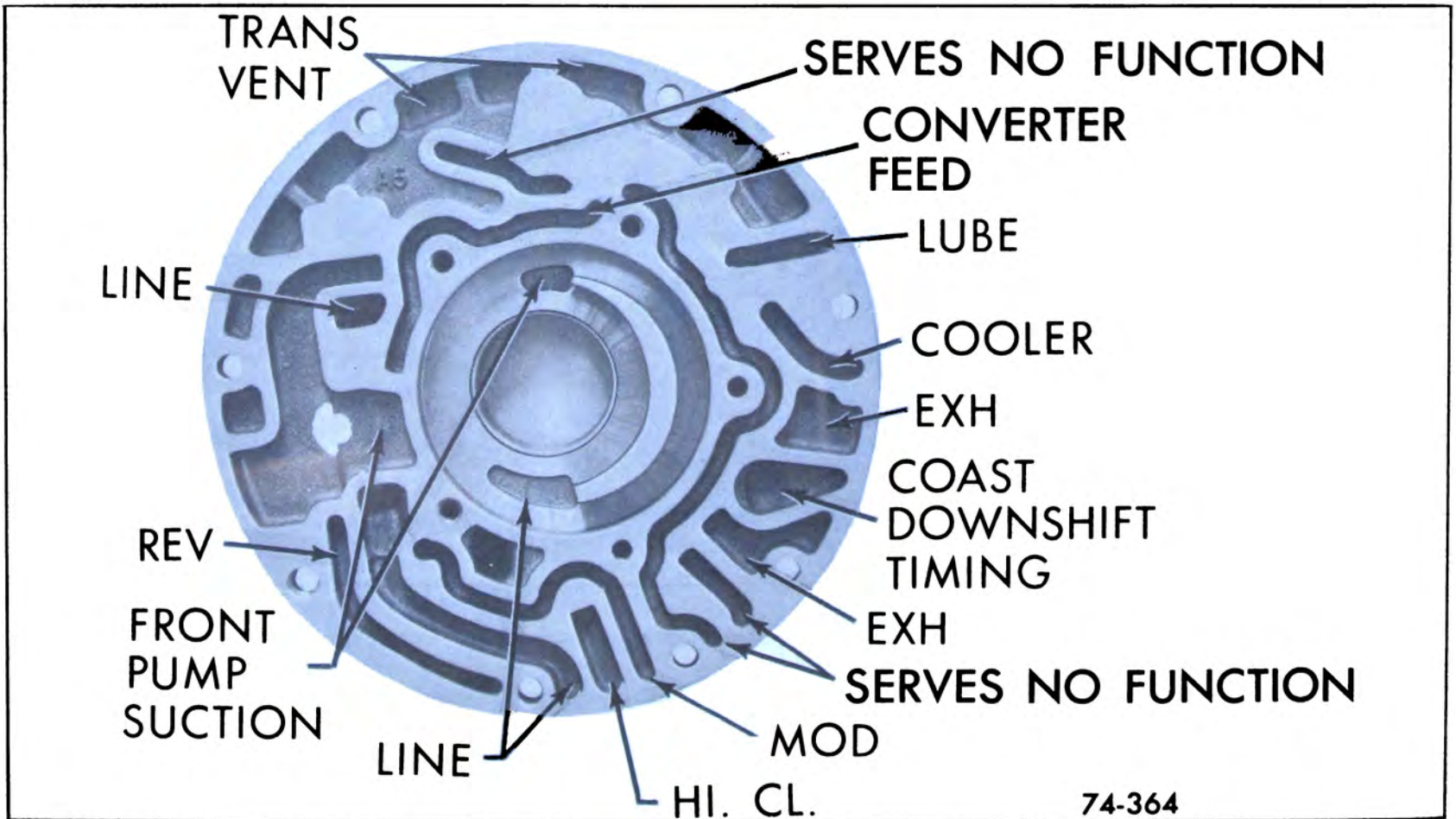

Figure 74-368—Oil Passages in Pump Body

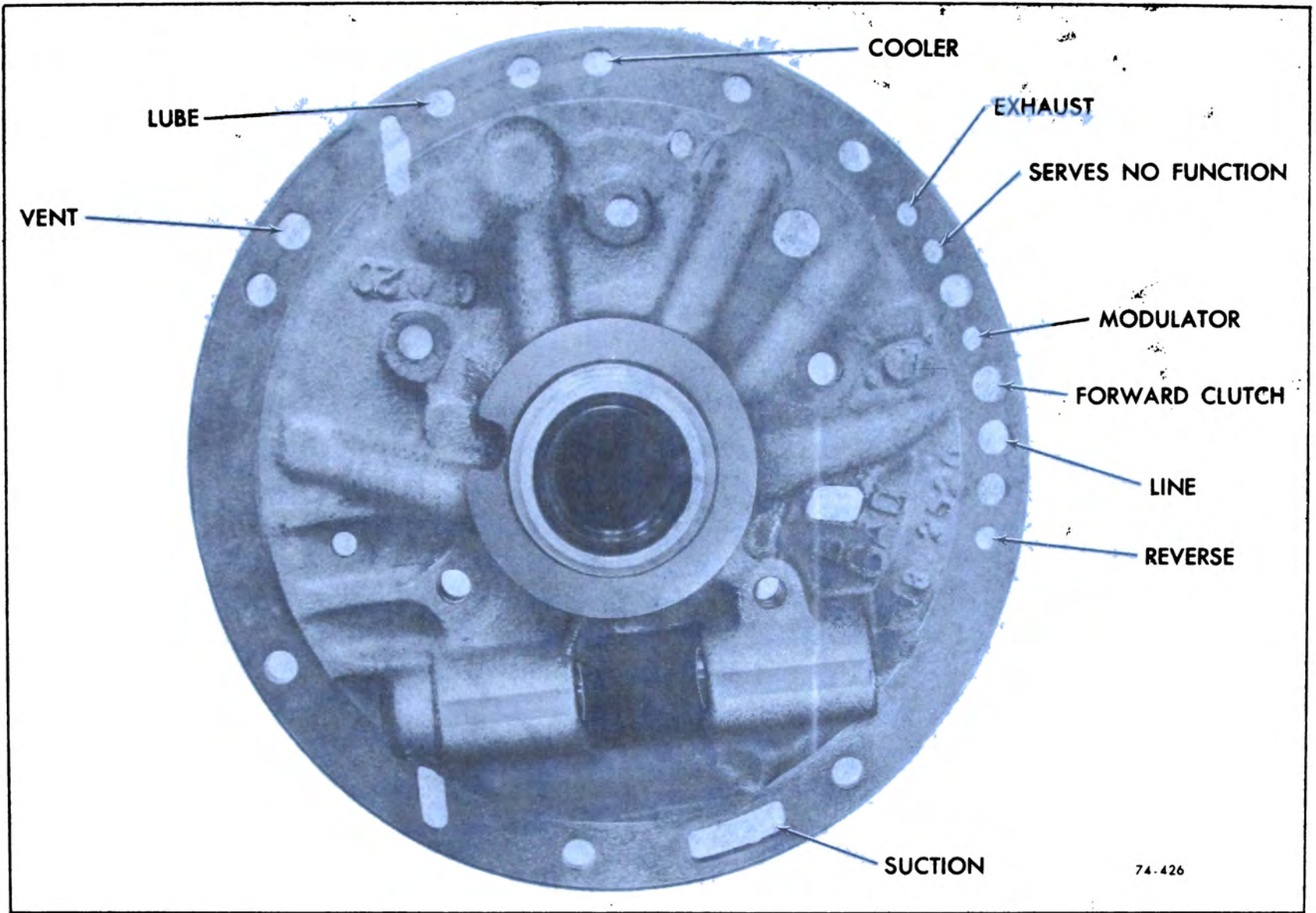

Figure 74-370—Oil Passages in Rear Face of Pump Cover

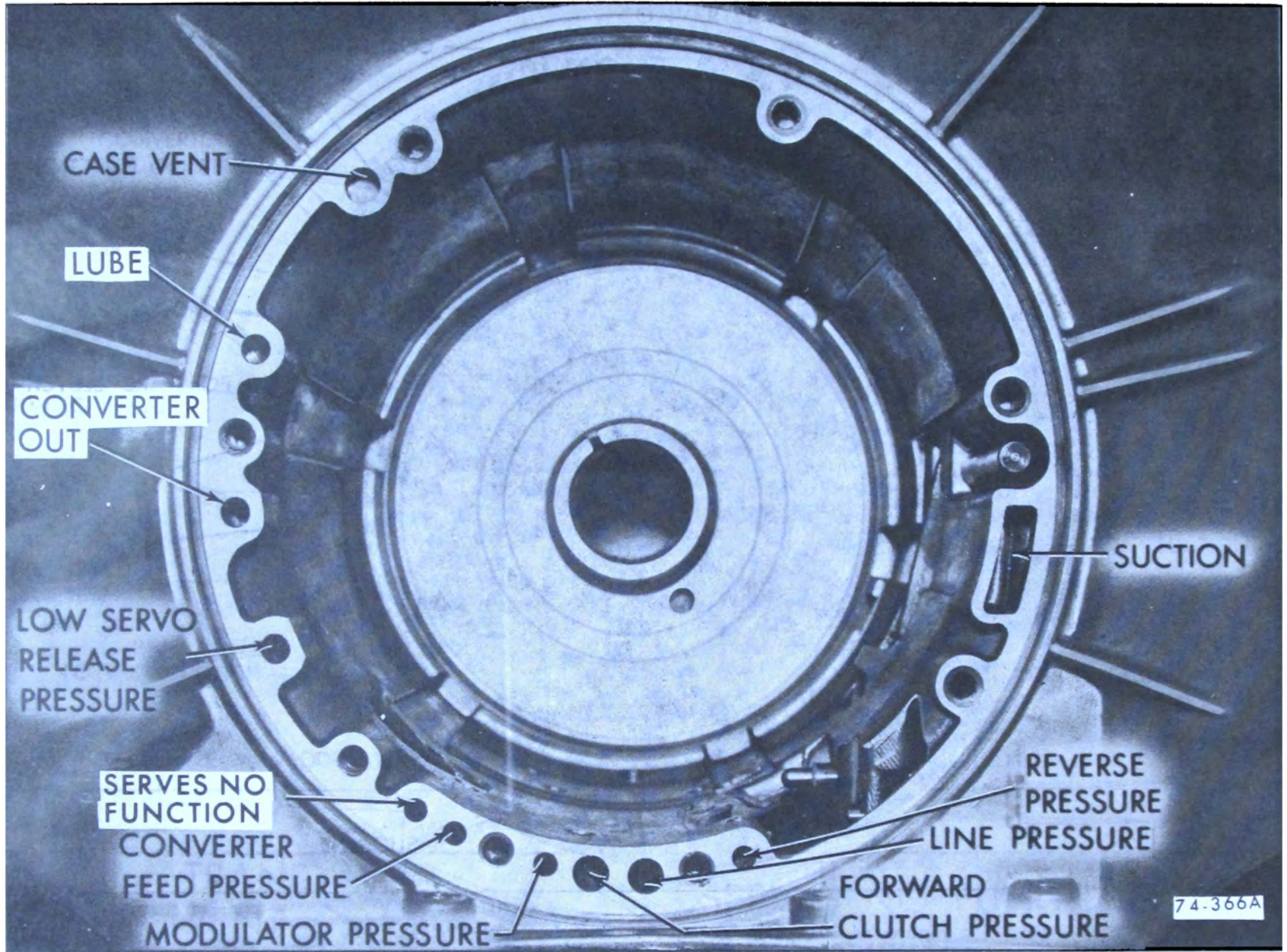
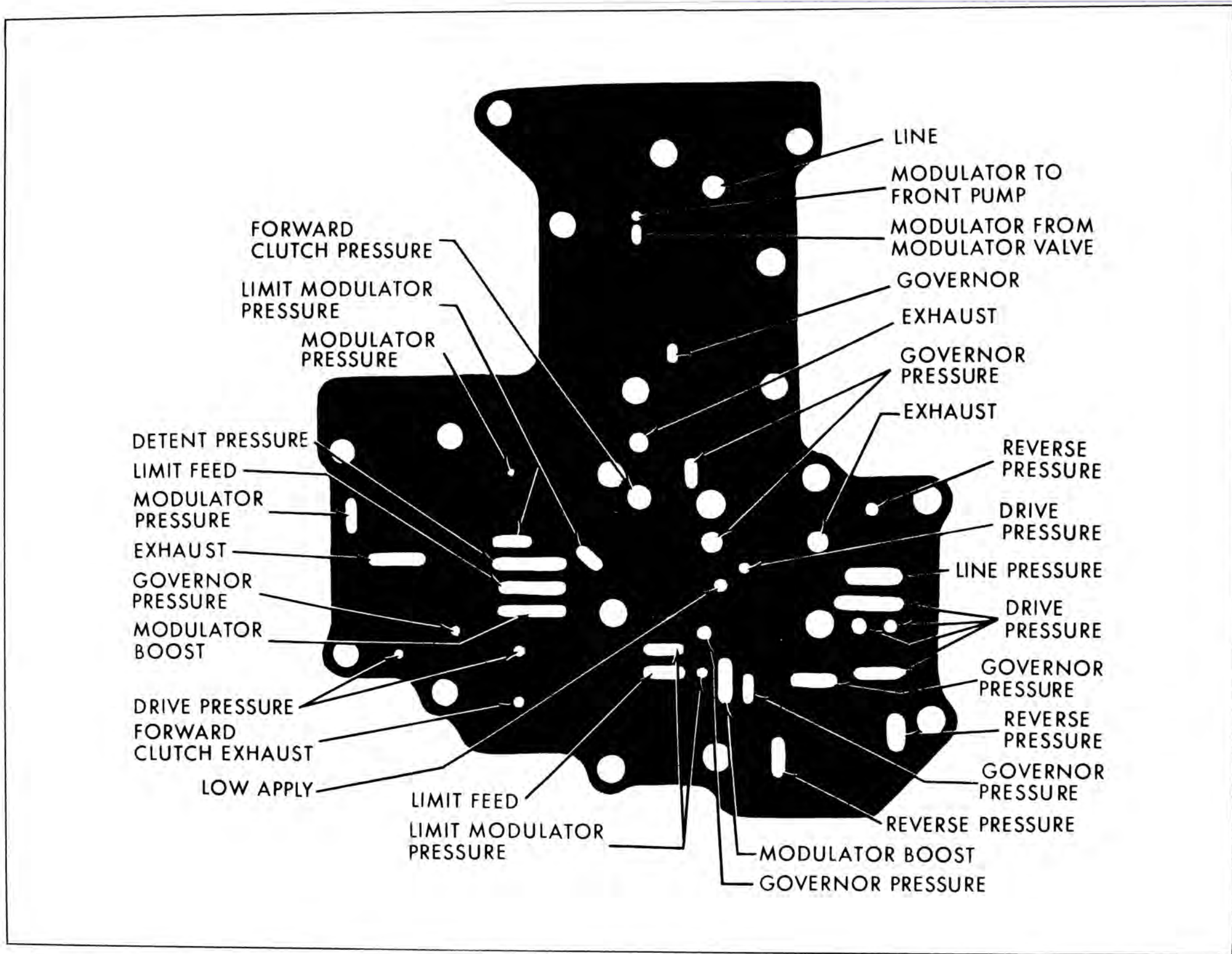

Figure 74-371—Oil Passages in Front of Transmission Case



FORWARD CLUTCH PRESSURE
 LIMIT MODULATOR PRESSURE
 MODULATOR PRESSURE

DETENT PRESSURE
 LIMIT FEED
 MODULATOR PRESSURE
 EXHAUST
 GOVERNOR PRESSURE
 MODULATOR BOOST

DRIVE PRESSURE
 FORWARD CLUTCH EXHAUST
 LOW APPLY

LIMIT FEED
 LIMIT MODULATOR PRESSURE

LINE
 MODULATOR TO FRONT PUMP
 MODULATOR FROM MODULATOR VALVE
 GOVERNOR
 EXHAUST
 GOVERNOR PRESSURE
 EXHAUST

REVERSE PRESSURE
 DRIVE PRESSURE
 LINE PRESSURE
 DRIVE PRESSURE
 GOVERNOR PRESSURE
 REVERSE PRESSURE
 GOVERNOR PRESSURE
 REVERSE PRESSURE
 MODULATOR BOOST
 GOVERNOR PRESSURE

Figure 74-372—Valve Body Plate

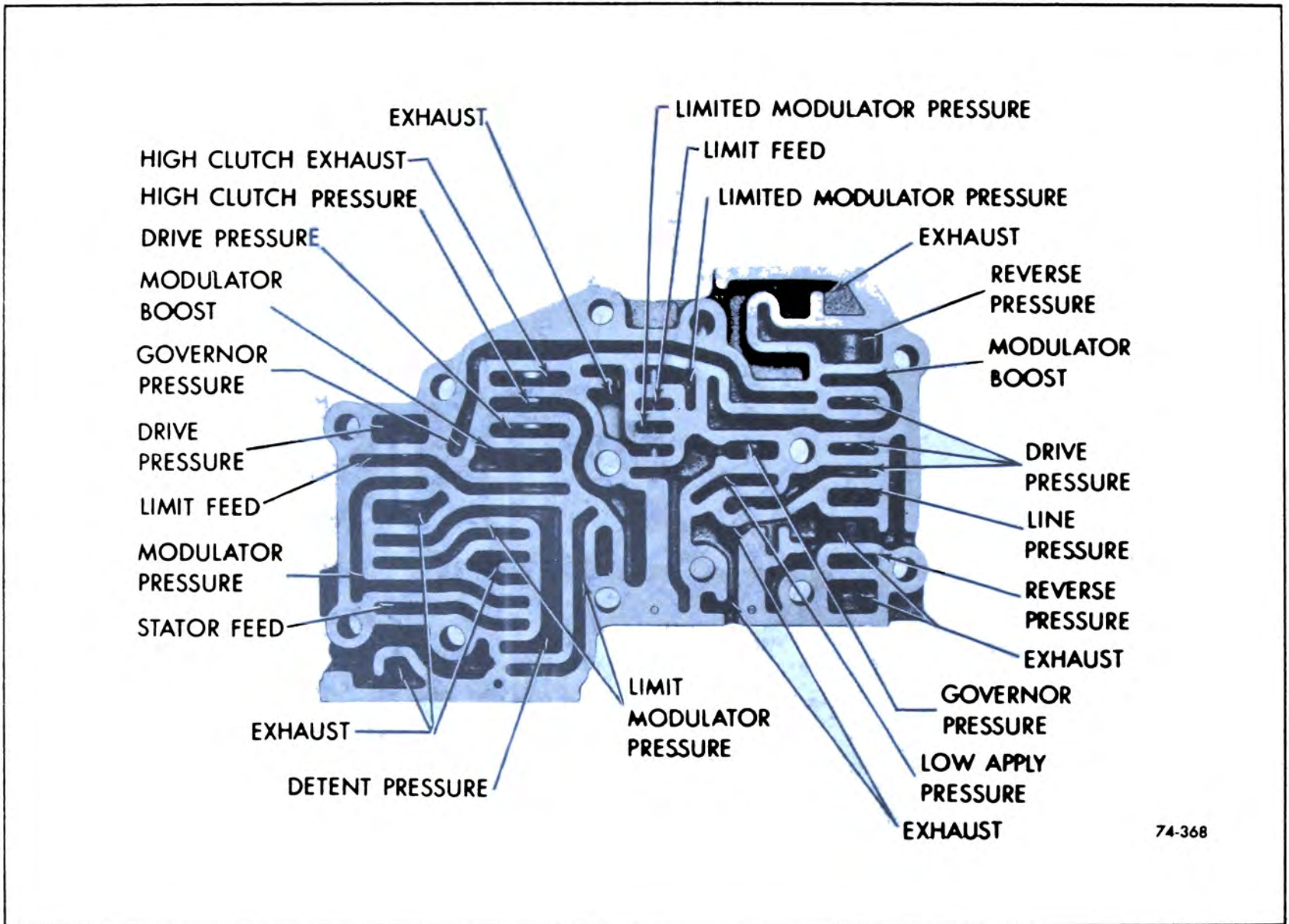

Figure 74-373—Oil Passages in Valve Body



Figure 74-374—Transmission Pressure Tap



Figure 74-375—Checking for Plug in Front Pump Cover

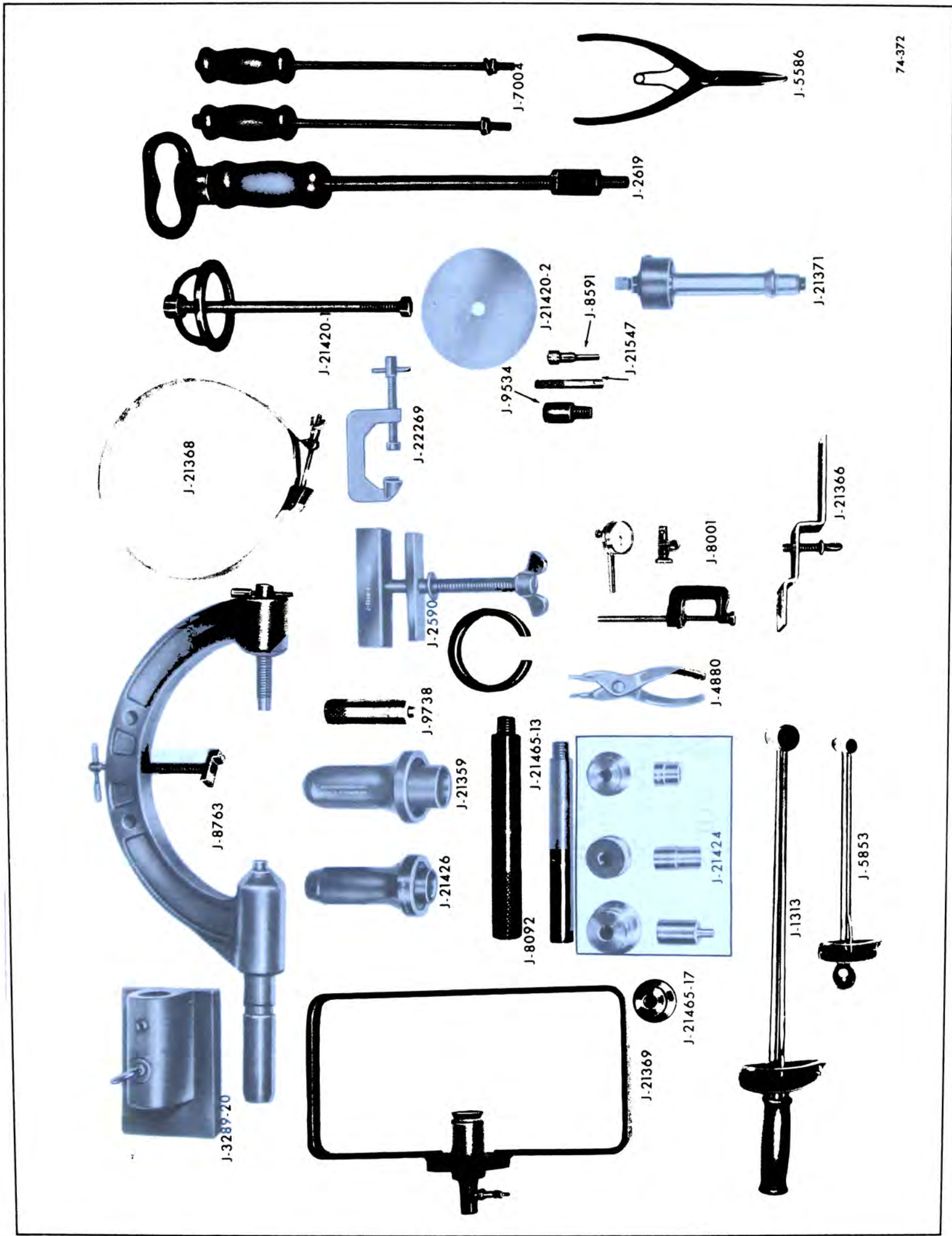

74-372

Figure 74-376—Special Tools

J-3289-20	-	HOLDING FIXTURE BASE
J-8763	-	HOLDING FIXTURE
J-21368	-	PUMP BODY TO COVER ALIGNMENT BAND
J-21420-1	-	REVERSE CLUTCH SPRING COMPRESSOR
J-21420-2	-	SLIDE HAMMER
J-7004	-	SLIDE HAMMER
J-2619	-	SNAP RING PLIERS
J-5586	-	CONVERTER END PLAY CHECKING FIXTURE
J-21371	-	MODULATOR LIMIT VALVE SPRING COMPRESSOR
J-21547	-	PLANET CARRIER BUSHING REMOVER
J-9534	-	DIAL INDICATOR SET
J-8001	-	CONVERTER HOLDING STRAP
J-21366	-	SNAP RING PLIERS
J-4880	-	FORWARD CLUTCH SPRING COMPRESSOR
J-2590	-	OUTER SHIFT LEVER SEAL INSTALLER
J-9738	-	OIL PUMP SEAL INSTALLER
J-21359	-	CASE EXTENSION OIL SEAL INSTALLER
J-21426	-	DRIVE HANDLE
J-8093	-	BUSHING SET
J-21424	-	FT. LB. TORQUE WRENCH
J-1313	-	IN. IB. TORQUE WRENCH
J-5853	-	CONVERTER PRESSURE CHECK FIXTURE
J-21369	-	PUMP BODY BUSHING REMOVER AND INSTALLER
J-21465-17	-	LOW SERVO COVER REMOVER AND INSTALLER
J-22269	-	

74-373