

SECTION A

MANUAL STEERING GEAR

ALL SERIES

CONTENTS

Division	Paragraph	Subject	Page
I		SPECIFICATIONS AND ADJUSTMENTS:	
	90-1	Manual Steering Gear Specifications	90-2
	90-2	Adjustment of Manual Steering Gear	90-3
II		DESCRIPTION AND OPERATION:	
	90-3	Description of Manual Steering Gear	90-4
III		SERVICE PROCEDURES:	
	90-4	Removal and Installation of Manual Gear Assembly	90-5
	90-5	Disassembly, Inspection, and Reassembly of Manual Steering Gear	90-5
IV		TROUBLE DIAGNOSIS:	
	90-6	Trouble Diagnosis	90-8

DIVISION I SPECIFICATIONS AND ADJUSTMENTS

90-1 MANUAL STEERING GEAR SPECIFICATIONS

a. Tightening Specifications (43-44-45-46000 Series)

Use a reliable torque wrench to tighten the parts listed to insure proper tightness without straining or distorting parts. These specifications are for clean and lightly lubricated threads only; dry or dirty threads produce increased friction which prevents accurate measurement of tightness.

Part	Location	Thread Size	Torque Lbs. Ft.
Bolt	Lower Coupling Pinch Flange	3/8-24	25-35
Bolt	Gear Side Cover to Housing	3/8-16	25-40
Bolt & Nut	Gear Housing to Frame	7/16-20	65
Nut	Lash Adjuster Lock	7/16-20	18-27
Nuts	Lower Coupling Flange to Steering Shaft Flange	5/16-18	25-35

b. Steering Gear Specifications (43-44000 Series)

Items	Specifications
Gear Type	Recirculating Ball Worm and Nut
Make	Saginaw
Ratio, Gear Only	24 to 1
Ratio, Overall (Including Linkage)	28 to 1
Turns of Wheel, Lt. to Rt. (Gear Connected)	5
Oil Capacity	11 oz.
Number and Type of Pitman Shaft Bearings	2 Bushings
Number and Type of Worm Shaft Bearings	2 Ball Bearings
Worm and Nut Balls - No. and Diameter	50, 9/32"
Adjusting Screw and Shim Clearance in Pitman Shaft	0 to .002"
Worm Bearing Preload - Torque at Spline	2 to 7 in. lbs.
Pitman Shaft Overcenter - Torque at Spline	4 to 8 in. lbs. Higher than Worm Bearing Preload

c. Manual Steering Gear Specifications (45-46000 Series)

Items	Specifications
Gear Type	Recirculating Ball Worm and Nut
Make	Saginaw
Ratio, Gear Only (45000 Series)	24.0 to 1
Ratio, Gear Only (46000 Series)	28.0 to 1
Ratio, Overall (Including Linkage) 45000 Series	33.2 to 1
Ratio, Overall (Including Linkage) 46000 Series	33.4 to 1
Turns of Steering Wheel Lock to Lock	5.8
Number and Type of Pitman Shaft Bearings	2 Bushings
Lubrication Capacity	11 oz.
Number and Type of Worm Shaft Bearings	2 Ball Bearings
Worm and Nut Balls - No. and Diameter	50, 9/32"
Lash Adjusting Screw and Shim Clearance in Pitman Shaft	0 to .002"
Adjustments	
Worm Bearing Preload	
Torque at Worm or Steering Shaft	5 to 9 in. lbs.
Lbs. Pull at Steering Wheel Rim	.62 to 1.2 lbs.
Pitman Shaft "Overcenter"	
Torque at Worm or Steering Shaft	5 to 11 in. lbs. Higher than Worm Bearing Preload
Lbs. Pull at Steering Wheel Rim	1/2 to 1 lb. Higher than Worm Bearing Preload
Total "Overcenter" Pull Should Not Exceed	18 in. lbs or 2.3 lbs.

90-2 ADJUSTMENT OF MANUAL STEERING GEAR

a. Adjustment of Steering Gear Out of Car

1. Attach Torque Wrench J-5853 to worm shaft and turn shaft to extreme right or left position. See Figure 90-1.
2. Turn worm shaft in opposite direction and adjust worm bearing adjuster to obtain a reading of 2 to 7 pound inches with worm shaft turning slowly. Worm bearing preload adjustment must be made within 1/2 turn of worm shaft from extreme position.
3. Tighten worm bearing adjuster lock nut and recheck reading.
4. Turn worm shaft from one extreme to the other while counting turns, then turn back 1/2 the total number of turns. This places the steering gear on the "high point".
5. Turn pitman shaft lash adjuster clockwise until a reading of 4 to 8 pound inches higher than worm bearing preload is obtained while rotating worm shaft through the "overcenter" range. Tighten lock nut and recheck reading.

Total "overcenter" pull should not exceed 13 pound inches.

b. Road Test After Adjustment

Road test car for ease of steering. If steering gear was adjusted to specified load limits and hard steering exists, the front suspension members should be checked for lubrication and alignment, and tire inflation pressures should be checked. When the car is moving straight ahead, the steering wheel should be in the straight-ahead position, or not over 5/8" to either side of the straight-ahead position. If steering wheel is too far to either side, check wheel for proper position on steering shaft (Figures 90-83 and 90-84) and check tie rods for equal adjustment and toe-in. It is important to have the steering gear in the no-lash range when car is moving straight forward.

c. Adjustment of Manual Steering Gear

IMPORTANT: Never attempt to adjust the steering gear while it is connected to pitman arm. The steering gear must be free of all outside load in order to properly make any steering gear adjustment.

d. Adjustment of Steering Gear in Car

1. Torque steering gear to cross member bolts to 60-70 lb. ft.
2. Disconnect pitman arm from steering gear by removing nut, and using puller J-5504.
3. Turn steering wheel slowly from one extreme to the other.

CAUTION: Never turn the wheel hard against the stopping point in the gear, as damage to the ball nut assembly may result.

NOTE: Steering wheel should turn freely and smoothly

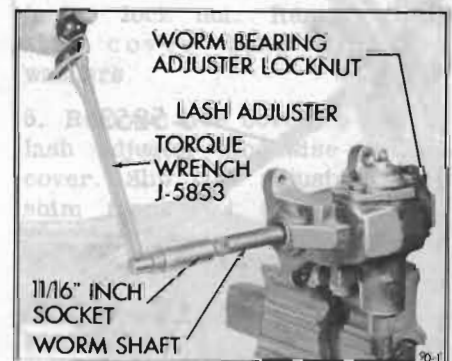

Figure 90-1—Checking Adjustments on Bench

through entire range. Roughness indicates faulty internal parts, requiring disassembly of the steering gear. Hard pull or binding indicates an excessively tight adjustment of worm bearings, or excessive misalignment of steering shaft. Any excessive misalignment must be corrected before steering gear can be properly adjusted.

4. Remove cap or horn actuator bar from steering wheel hub.

5. Check worm bearing preload by turning steering wheel gently in one direction until it stops. This positions gear away from "high point" load.

6. Attach torque wrench J-5853 to steering wheel nut and check the torque required to turn the wheel (see Figure 90-2). The torque required to keep wheel turning should be between 2 and 7 pound inches and should be measured within 1/2 turn from extreme position.

7. If necessary adjust worm bearing preload by loosening worm bearing adjuster lock nut using a drift (see Figure 90-1). Turn bearing adjuster as required to bring torque between 2 and 7 pound inches. Tighten lock nut, then recheck preload.

8. Torque side cover bolts to 30 lbs. ft.

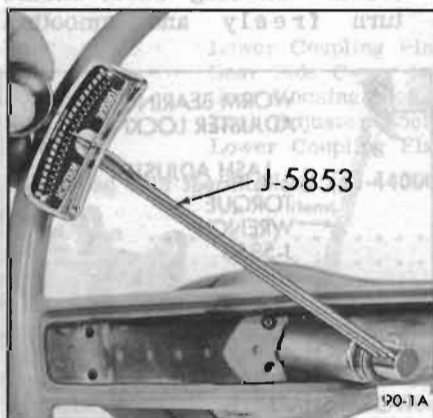

Figure 90-2—Checking Adjustments in Car

9. Check pitman shaft overcenter preload by turning steering wheel from one extreme to the other while counting the total turns, then turn wheel back 1/2 the number of turns. This positions steering gear on "high point" where a preload should exist between ball nut and pitman shaft teeth.

10. Check the torque required to turn wheel through the "high point" range. Torque should be between 4 and 8 pound inches higher than worm bearing preload. Adjust pitman shaft lash adjuster if necessary. Total "overcenter" pull should not exceed 13 pound inches.

11. Adjust pitman shaft overcenter preload by loosening lock nut and turning pitman shaft lash adjuster screw as required to bring torque between 4 and 8 pound inches higher than worm bearing preload. After tightening lock nut, rotate steering wheel back and forth through the "high point" and through the entire range to insure no tight spots exist.

NOTE: If lash cannot be removed at "high point", or if

gear load varies greatly and feels rough, gear assembly should be removed for inspection of internal parts.

12. Attach pitman arm to steering gear and torque nut to 120-160 lbs. ft.

DIVISION II

DESCRIPTION AND OPERATION

90-3 DESCRIPTION OF MANUAL STEERING GEAR

The steering gear is the recirculating ball worm and nut type. The worm on lower end of the steering shaft and the ball nut which is mounted on the worm have mating spiral grooves in which steel balls circulate to provide a low-friction drive between worm and nut (See Figure 90-3).

Teeth on the ball nut engage teeth on a sector forged integral with the pitman shaft. The teeth on the ball nut are made so that a "high point" or tighter fit exists between the ball nut and pitman shaft sector teeth when front wheels are in the straight-ahead position. The teeth of sector are slightly tapered so that a proper

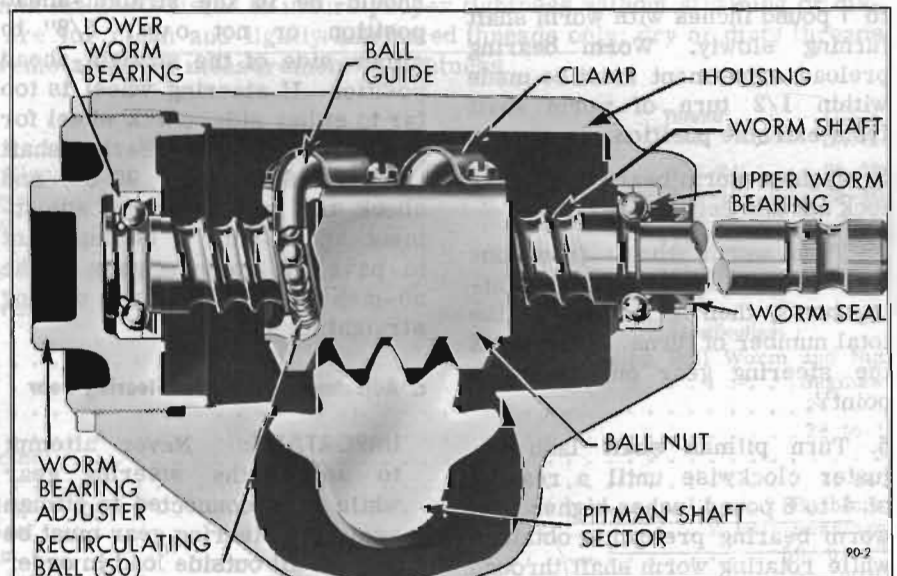

Figure 90-3—Steering Gear Worm and Ball Nut

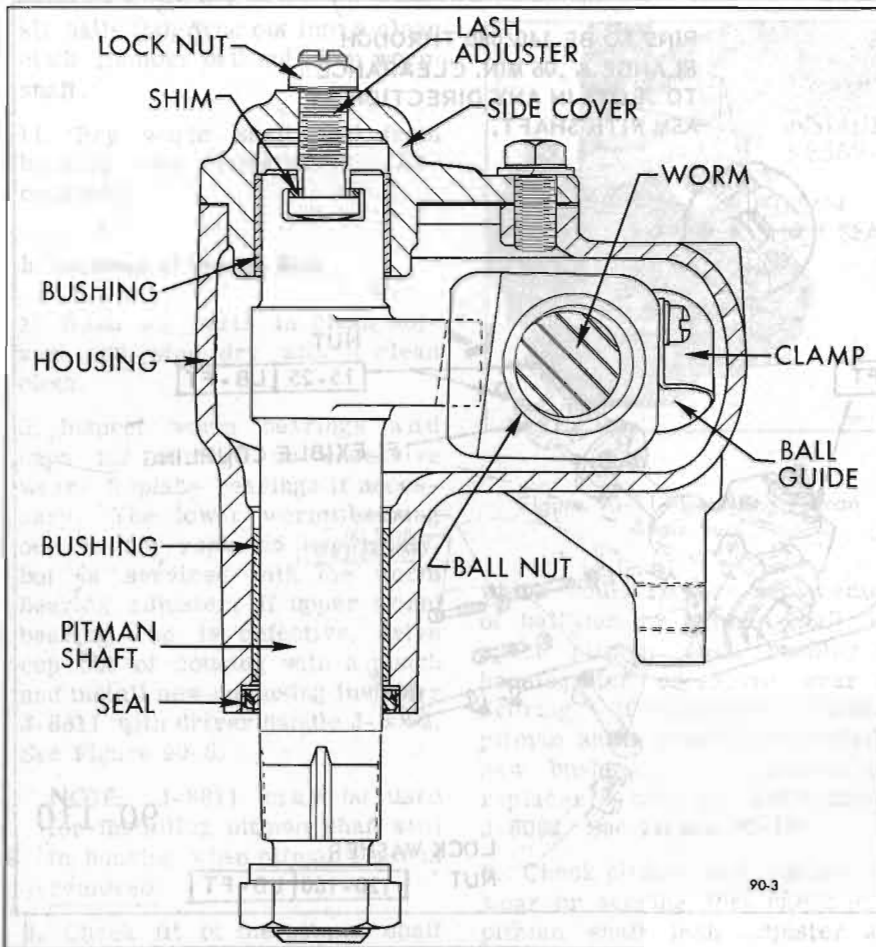

Figure 90-4—Steering Gear Pitman Shaft and Ball Nut

lash may be obtained by moving the pitman shaft endways by means of a lash adjuster screw which extends through the gear housing side cover. The head of lash adjuster and a selectively fitted shim fit snugly into a T-slot in the end of the pitman shaft, so that the screw also controls end play of shaft. See Figure 90-4.

DIVISION III SERVICE PROCEDURES

90-4 REMOVAL AND INSTALLATION OF MANUAL GEAR ASSEMBLY (43-44-45-46000 SERIES)

a. Removal of Steering Gear

1. Remove two nuts securing halves of flexible coupling together.

2. Remove pitman nut and disconnect pitman shaft from gear by use of puller J-5504.

CAUTION: When pulling pitman arm from pitman shaft, do not hammer on end of puller as damage will result to gear. If necessary, tapping on side of pitman arm may help in removing arm.

3. Remove three steering gear to frame bolts and remove gear assembly. See Figure 90-5.

b. Installation of Steering Gear

NOTE: If flexible coupling was removed be sure to reinstall coupling so that tab on coupling is aligned with mark on gear worm shaft. See Figure 90-6.

1. Install gear and torque bolts 65 lbs. ft.

2. Install two nuts on studs of flexible coupling and tighten to 15-20 lb. ft.

3. Reconnect pitman arm to gear pitman shaft and torque pitman nut 120-160 lb. ft.

90-5 DISASSEMBLY, INSPECTION, AND REASSEMBLY OF MANUAL STEERING GEAR (43-44-45-46000 SERIES)

a. Disassembly of Steering Gear

NOTE: It is not necessary to disassemble gear to replace worm seal. Remove worm seal with an awl being careful not to damage housing or shaft and install a new seal with installer J-8564. See Figure 90-12.

1. Thoroughly clean exterior of gear assembly with a suitable solvent.

2. Place steering gear in a soft jaw vise.

NOTE: If only pitman shaft seal is going to be replaced do not disassemble pitman shaft and side cover, but remove seal with an awl and install seal using installer J-8569 (see Figure 90-11).

3. Rotate worm shaft to center of travel, approximately 3-1/2 turns from either extreme.

4. Remove pitman shaft lash adjuster lock nut. Remove three side cover bolts and lock washers.

5. Remove side cover by turning lash adjuster clockwise through cover. Slip lash adjuster with shim from slot end of pitman shaft. Remove and discard side cover gasket.

6. Remove pitman shaft from housing by lightly tapping on spline end with a soft mallet. Pry pitman shaft seal out of housing with a screwdriver. Discard seal.

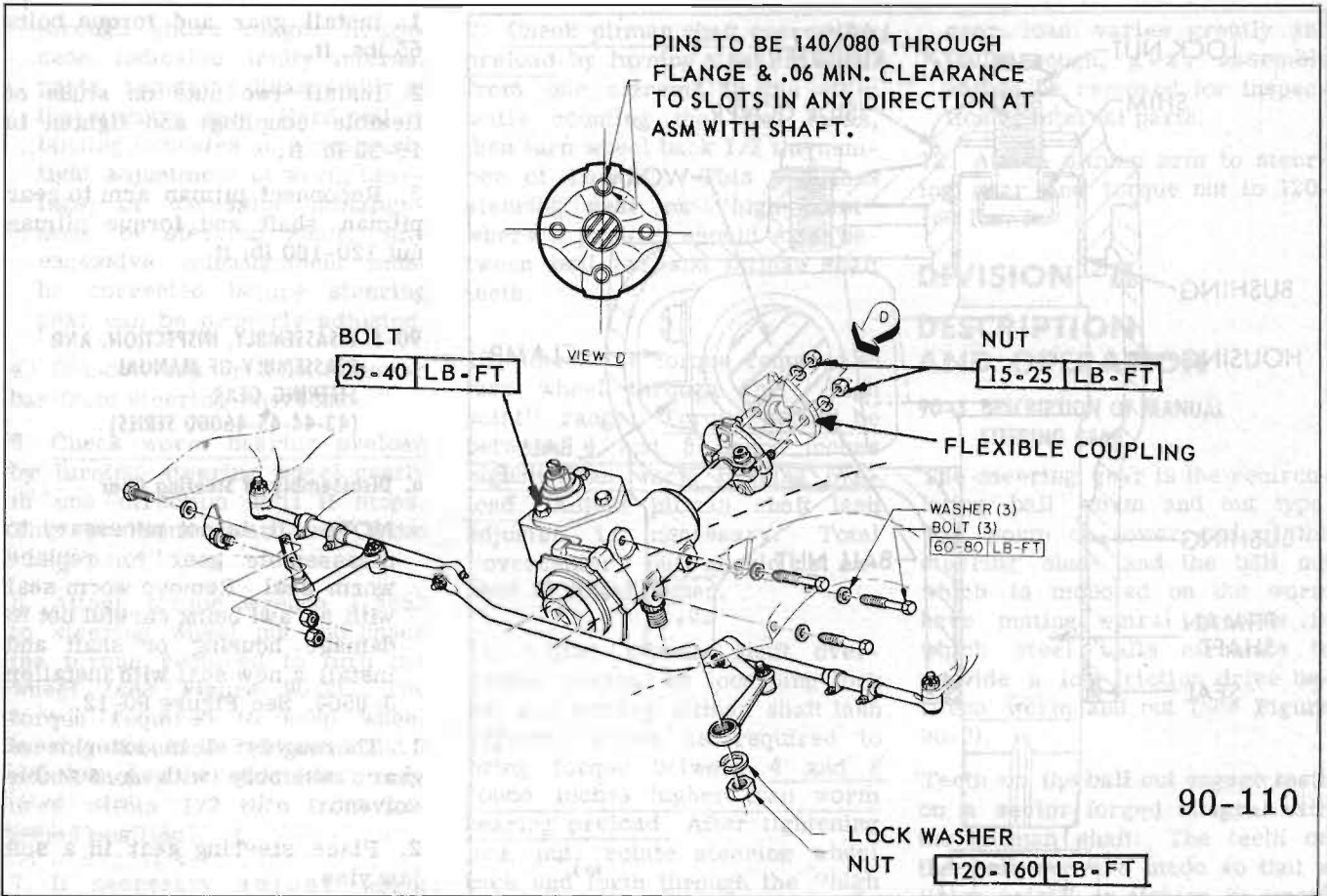

Figure 90-5—Manual Steering Gear Installation (All Series)

7. Loosen worm bearing adjuster lock nut with a punch and remove worm bearing adjuster and lock nut.

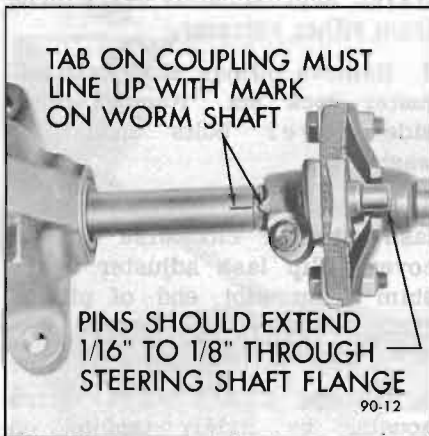

Figure 90-6—Gear Flexible Coupling Installation

8. Remove worm shaft and ball nut assembly, and also upper worm bearing from housing.

9. Remove lower worm bearing from adjuster by prying retainer

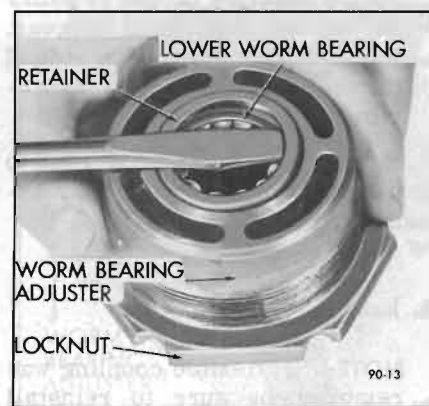

Figure 90-7—Removing Lower Worm Bearing Retainer

out with a screwdriver. See Figure 90-7.

10. Remove ball return guide clamp and guides from ball nut. Turn ball nut over and rotate worm shaft back and forth until

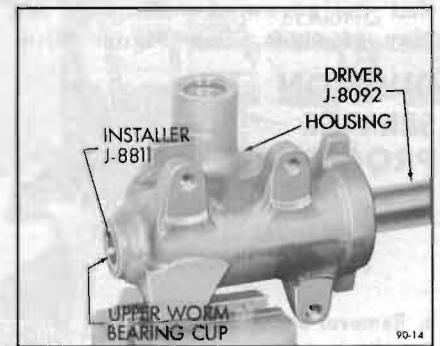

Figure 90-8—Installing Upper Worm Bearing Cup

all balls (50) drop out into a clean cloth. Remove ball nut from worm shaft.

11. Pry worm shaft seal from housing with screwdriver. Discard seal.

b. Inspection of Steering Gear

1. Wash all parts in clean solvent and wipe dry with a clean cloth.

2. Inspect worm bearings and cups for damage or excessive wear. Replace bearings if necessary. The lower worm bearing cup is not replaced separately, but is serviced with the worm bearing adjuster. If upper worm bearing cup is defective, drive cup out of housing with a punch and install new cup using installer J-8811 with driver handle J-8092. See Figure 90-8.

NOTE: J-8811 may be used for installing pitman shaft seal in housing when pitman shaft is removed.

3. Check fit of the pitman shaft in the bushing of side cover. If bushing is worn, side cover must be replaced as bushing is not serviced separately.

4. Inspect the worm and nut balls and the grooves of worm and nut for damage or excessive wear. Replace parts as necessary.

5. Inspect teeth of ball nut and pitman shaft for pitting or scoring

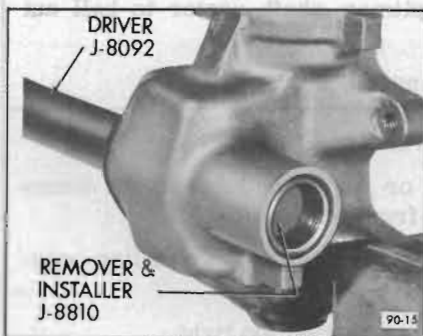

Figure 90-10—Installing Pitman Shaft Bushing



Figure 90-11—Installing Pitman Shaft Seal

which would require replacement of ball nut or pitman shaft. Inspect pitman shaft bushing in housing for excessive wear or scoring. If necessary, remove pitman shaft bushing and install a new bushing with remover and replacer J-8810 and driver handle J-8092. See Figure 90-10.

6. Check pitman shaft surface for wear or scoring, then check fit of pitman shaft lash adjuster and shim in the slot in end of pitman shaft by inserting feeler gauge between the head of screw and bottom of slot. Adjuster must be free to turn and end play should not exceed .002". If end play exceeds .002" install proper shim. The shims are available in four different thicknesses -- .063", .065", .067", and .069".

7. Check ball guides for damage and replace if necessary.

c. Assembly of Steering Gear

NOTE: Lubricate all seals, bushings, bearings and gears with multi-purpose gear lubricant just before assembling.

1. Position ball nut over worm shaft so that deep side of teeth will be toward side cover when installed in gear housing. Install

19 balls in each circuit (rock worm shaft slightly to aid in installing balls). Place 6 balls in each return guide, using grease to hold balls in place. Install return guides, clamp and screws. Rotate worm through its complete travel several times to insure balls are installed correctly and rotate freely.

2. Place upper bearing on worm shaft and slide worm shaft assembly into housing.

3. Place lower bearing in worm bearing adjuster and install bearing retainer with installer J-8564. Install adjuster assembly and lock nut on housing. Tighten adjuster only enough to hold worm bearings in place. Final adjustment will be made later.

4. Turn worm shaft until second and third teeth of ball nut line up with center tooth of pitman shaft. Assemble pitman shaft and lash adjuster with shim and install pitman shaft so that center tooth meshes with center groove in ball nut.

5. Place new gasket on side cover. Install side cover with gasket on lash adjuster by turning adjuster counterclockwise.

6. Install three side cover bolts and lock washers. Torque bolts 25-40 lb. ft.

7. Turn lash adjuster so that



Figure 90-12—Installing Worm Shaft Seal

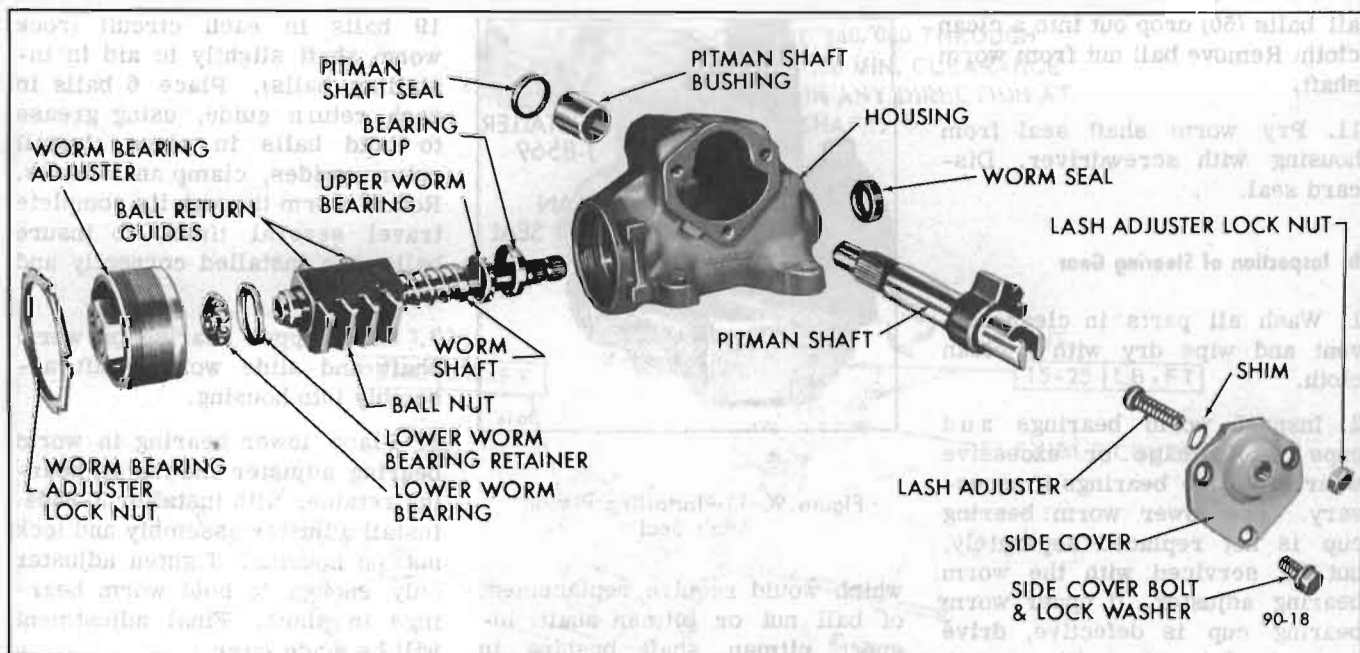

Figure 90-13—Manual Steering Gear (Exploded View)

teeth on shaft and ball nut engage smoothly but do not bind. Install lash adjuster lock nut loosely. Final adjustment will be made later.

8. To protect pitman shaft seal from damage, cover shaft splines with masking tape. Slide new seal into place and seat against shoulder on housing using instal-

ler J-8569. See Figure 90-11.

9. Install new worm shaft seal using installer J-8564. See Figure 90-12. Drive seal flush with surface of housing.

10. Fill steering gear with chassis lubricant. Gear is now ready for final adjustment as described in paragraph 90-2.

DIVISION IV

TROUBLE DIAGNOSIS

90-6 TROUBLE DIAGNOSIS—MANUAL STEERING GEAR

This paragraph covers steering malfunctions which are most likely to be caused by the steering gear assembly or tie rods.

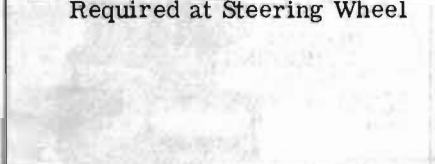
<p>a. Excessive Play or Looseness in Steering System</p> 	<ol style="list-style-type: none"> 1. Front wheel bearings loosely adjusted. (par. 100-3) 2. Worn upper ball joints (Group 30) 3. Steering wheel loose on shaft, loose pitman arm, tie rods, steering arms or steering linkage ball studs. 4. Excessive pitman shaft sector to ball nut lash. 5. Worn bearings loosely adjusted.
<p>b. Hard Steering--Excessive Effort Required at Steering Wheel</p> 	<ol style="list-style-type: none"> 1. Low or uneven tire pressure. 2. Insufficient or improper lubricant in steering gear or front suspension. 3. Excessive steering shaft coupling misalignment. 4. Steering gear adjusted too tight. 5. Front wheel alignment incorrect.

<p>c. Battle or Chuckle in Steering Gear</p>	<ol style="list-style-type: none"> 1. Insufficient or improper lubricant in steering gear. 2. Excessive back lash between ball nut and pitman shaft sector in straight ahead position or worm thrust bearings adjusted too loose. <p>NOTE: On turns a slight rattle may occur, due to the increased lash between ball nut and sector as gear moves off the center of "high point" position. This is normal and lash must not be reduced to eliminate this slight rattle.</p> <ol style="list-style-type: none"> 3. Pitman arm loose on shaft or steering gear loose at mounting bolts. 4. Loose or worn steering shaft bearing.
<p>d. Poor Returnability</p>	<ol style="list-style-type: none"> 1. Steering gear adjusted too tight. 2. Front wheel alignment incorrect. 3. Insufficient or improper lubricant in steering gear or front suspension. 4. Steering column misaligned

DIVISION I SPECIFICATIONS AND ADJUSTMENTS

POWER STEERING GEAR AND PUMP

a. Tightening Specifications

Use a reliable torque wrench to tighten the parts of the power steering system without stretching or distorting parts. The specifications are for steel parts only. Dry or oily threads increase friction which produces higher torque requirements of tightness.

Part	Specification
Ball Joint	20-30
Control Arm	20-30
Coil Spring	20-30
Leaf Spring	20-30
Shock Absorber	20-30
Stabilizer Bar	20-30
Upper Control Arm	20-30
Lower Control Arm	20-30
Strut Rod	20-30
Ball Joint	20-30
Control Arm	20-30
Coil Spring	20-30
Leaf Spring	20-30
Shock Absorber	20-30
Stabilizer Bar	20-30
Upper Control Arm	20-30
Lower Control Arm	20-30
Strut Rod	20-30

